

# TPDxE05U06、超高速 (最大 6Gbps) インターフェイス用 1/4/6 チャンネル ESD 保護デバイス

## 1 特長

- IEC 61000-4-2 レベル 4 ESD 保護
  - ±12kV 接触放電
  - ±15kV エアギャップ放電
- IEC 61000-4-4 EFT 保護
  - 80A (5/50ns)
- IEC 61000-4-5 サージ保護
  - 2.5A (8/20µs)
- IO 容量: 0.42pF ~ 0.5pF (標準値)
- DC ブレークダウン電圧: 6.5V (最小値)
- 超低リーク電流: 10nA (最大値)
- 低 ESD クランプ電圧
- 産業用温度範囲: -40°C ~ +125°C
- 使いやすいストレート・スルー・ルーティング・パッケージ
- 業界標準の SOD-523 パッケージ (1.60mm × 0.80mm × 0.65mm)

## 2 アプリケーション

- [HDMI 1.4b](#)
- [HDMI 2.0](#)
- [USB 3.0](#)
- [MHL](#)
- [LVDS インターフェイス](#)
- [DisplayPort](#)
- [PCI-express®](#)
- [eSata インターフェイス](#)
- [V-by-One® HS](#)

## 3 概要

TPDxE05U06 は、超低容量の単方向過渡電圧サプレッサ (TVS) ベースの静電気放電 (ESD) 保護ダイオード・ファミリです。各デバイスは、IEC 61000-4-2 国際規格で規定されている最大レベルを上回る ESD のエネルギーを消費できます。TPDxE05U06s の超低負荷容量により、あらゆる高速信号ピンを理想的に保護します。

TPDxE05U06 の代表的なアプリケーションには、HDMI 1.4b、HDMI 2.0、USB 3.0、MHL、LVDS、DisplayPort、PCI-Express®、eSata および V-by-One® HS の高速信号ラインが含まれます。

### 製品情報<sup>(1)</sup>

部品番号	パッケージ	本体サイズ (公称)
TPD1E05U06	X1SON (2)	0.60mm × 1.00mm
	SOD-523 (2)	0.80mm × 1.20mm
TPD4E05U06	USON (10)	2.50mm × 1.00mm
TPD6E05U06	USON (14)	3.50 mm × 1.35 mm

(1) 利用可能なすべてのパッケージについては、このデータシート末尾にある注文情報を参照してください。

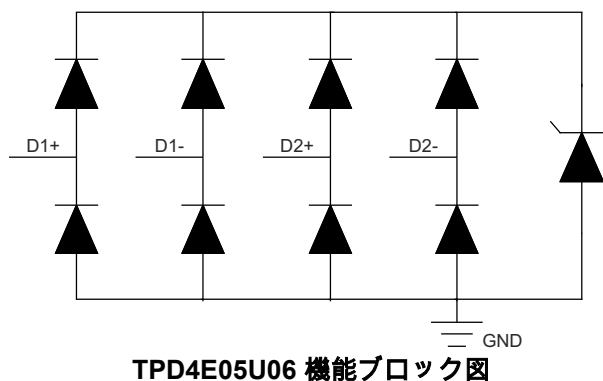
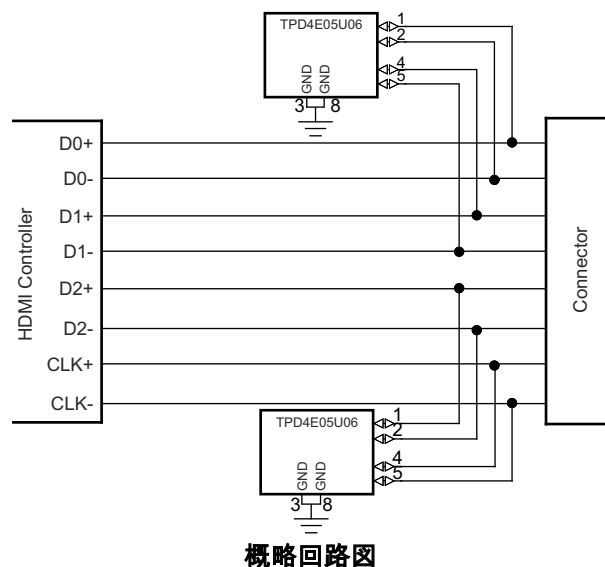

## Table of Contents

<b>1 特長</b> .....	1	7.4 Device Functional Modes.....	12
<b>2 アプリケーション</b> .....	1	<b>8 Application and Implementation</b> .....	13
<b>3 概要</b> .....	1	8.1 Application Information.....	13
<b>4 Revision History</b> .....	2	8.2 Typical Applications.....	13
<b>5 Pin Configuration and Functions</b> .....	4	<b>9 Power Supply Recommendations</b> .....	16
<b>6 Specifications</b> .....	6	<b>10 Layout</b> .....	17
Absolute Maximum Ratings.....	6	10.1 Layout Guidelines.....	17
6.1 ESD Ratings—JEDEC Specification.....	6	10.2 Layout Example.....	17
6.2 ESD Ratings—IEC Specification.....	6	<b>11 Device and Documentation Support</b> .....	19
Recommended Operating Conditions.....	6	11.1 Documentation Support.....	19
6.3 Thermal Information.....	7	11.2 Receiving Notification of Documentation Updates..	19
6.4 Electrical Characteristics.....	7	11.3 サポート・リソース.....	19
6.5 Typical Characteristics.....	9	11.4 Trademarks.....	19
<b>7 Detailed Description</b> .....	11	11.5 Electrostatic Discharge Caution.....	19
7.1 Overview.....	11	11.6 Glossary.....	19
7.2 Functional Block Diagram.....	11	<b>12 Mechanical, Packaging, and Orderable Information</b> .....	19
7.3 Feature Description.....	12		

## 4 Revision History

資料番号末尾の英字は改訂を表しています。その改訂履歴は英語版に準じています。

<b>Changes from Revision M (January 2017) to Revision N (February 2022)</b> .....	<b>Page</b>
• SOD-523 パッケージ情報を、ボディ・サイズ (0.8mm × 1.2mm) からリード間寸法 (1.60mm × 0.80mm × 0.65mm) に更新.....	1
<b>Changes from Revision L (January 2017) to Revision M (December 2021)</b> .....	<b>Page</b>
• 文書全体にわたって表、図、相互参照の採番方法を更新.....	1
• 「特長」セクションを更新し、SOD-523 パッケージ情報を追加.....	1
• 「製品情報」表に DYA パッケージを追加.....	1
• Added the DYA package to the <i>Pin Configuration and Functions</i> section.....	4
• Changed the minimum <i>DC breakdown voltage</i> from 6 V to 6.5 V in the <i>Detailed Description</i> section.....	12
• Changed the minimum <i>reverse standoff voltage</i> from 5 V to 5.5 V in the <i>Detailed Description</i> section.....	12
• Updated the <i>Related Documentation</i> section.....	19
<b>Changes from Revision K (November 2016) to Revision L (January 2017)</b> .....	<b>Page</b>
• Updated DPY pinout image.....	4
• Updated title from TPD4E05U06 to TPD6E05U06 in <a href="#">図 7-3</a> .....	11
<b>Changes from Revision J (March 2016) to Revision K (November 2016)</b> .....	<b>Page</b>
• Changed min value of $V_{BR}$ from 6 V to 6.5 V in the <i>Electrical Characteristics</i> table.....	6
<b>Changes from Revision I (June 2015) to Revision J (March 2016)</b> .....	<b>Page</b>
• X2SON のすべてを X1SON に置き換え.....	1
• Update the <i>Pin Functions</i> table.....	4
• Added the <i>Power Supply Recommendations</i> section.....	16
<b>Changes from Revision H (May 2015) to Revision I (June 2015)</b> .....	<b>Page</b>
• 商標の追加.....	1
• Corrected TPD6E05U06 Pin 13 name.....	4
• Corrected TLP definition.....	6

<b>Changes from Revision G (July 2014) to Revision H (May 2015)</b>		<b>Page</b>
• 追加アプリケーションを追加.....		1
• Updated with HDMI 2.0 Eye Diagrams.....		14
<b>Changes from Revision F (November 2013) to Revision G (July 2014)</b>		<b>Page</b>
• 61000-4-4 EFT 準拠を追加.....		1
• Added <i>Thermal Information</i> table.....		6
• Added <i>Handling Ratings</i> table.....		6
• Added the <i>Detailed Description</i> section.....		11
• Added the <i>Application and Implementation</i> section.....		13
• Added Layout section. ....		17
<b>Changes from Revision * (December 2012) to Revision A (December 2012)</b>		<b>Page</b>
• ドキュメントに TPS2EUSB30A を追加.....		1
<b>Changes from Revision A (December 2012) to Revision B (January 2013)</b>		<b>Page</b>
• Added Insertion Loss Graphic.....		9
• Added Eye Diagrams.....		14
<b>Changes from Revision B (January 2013) to Revision C (March 2013)</b>		<b>Page</b>
• IO 容量範囲を変更.....		1
• Changed test conditions and typ values for $V_{clamp}$ .....		6
• Added typ $R_{DYN}$ values for DQA and RVZ packages.....		6
• Added $C_L$ values for DQA and RVZ packages.....		6
• Changed CURRENT vs VOLTAGE graphic.....		9
• Changed Insertion Loss graphic.....		9
• Changed HDMI Eye Diagrams.....		14
<b>Changes from Revision C (March 2013) to Revision D ( )</b>		<b>Page</b>
• タイトルを更新.....		1
• Removed Ordering Information table.....		4
<b>Changes from Revision D (August 2013) to Revision E (November 2013)</b>		<b>Page</b>
• ドキュメントのフォーマットを更新.....		1
• 追加アプリケーションを追加.....		1

## 5 Pin Configuration and Functions



图 5-1. DPY Package 2-Pin X1SON Top View



图 5-2. DYA Package 2-Pin SOD-523 Top View

表 5-1. Pin Functions TPD1E05U06 DPY and DYA

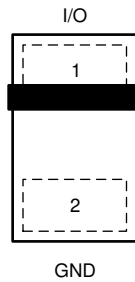
PIN		TYPE	DESCRIPTION
NAME	NO.		
GND	2	Ground	Ground; Connect to ground
I/O	1	I/O	ESD protected channel <sup>(1)</sup>

(1) Place as close to the connector as possible.

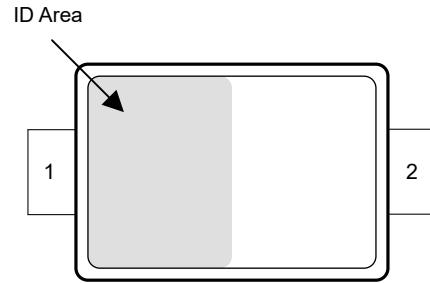

图 5-3. DQA Package 10-Pin USON Top View

表 5-2. Pin Functions TPD4E05U06 DQA

PIN		TYPE	DESCRIPTION
NAME	NO.		
D1+	1	I/O	ESD protected channel <sup>(1)</sup>
D1–	2	I/O	ESD protected channel <sup>(1)</sup>
D2+	4	I/O	ESD protected channel <sup>(1)</sup>
D2–	5	I/O	ESD protected channel <sup>(1)</sup>
GND	3	Ground	Ground; Connect to ground
GND	8		
NC	6	—	Not connected; Used for optional straight-through routing. Can be left floating or grounded
NC	7		
NC	9		
NC	10		
NC	10		

(1) Place as close to the connector as possible.

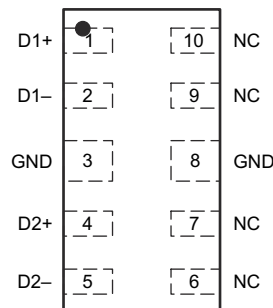

图 5-4. RVZ Package 14-Pin USON Top View

表 5-3. Pin Functions TPD6E05U06 RVZ

PIN		TYPE	DESCRIPTION
NAME	NO.		
D1+	14	I/O	ESD protected channel <sup>(1)</sup>
D1-	13	I/O	ESD protected channel <sup>(1)</sup>
D2+	12	I/O	ESD protected channel <sup>(1)</sup>
D2-	11	I/O	ESD protected channel <sup>(1)</sup>
D3+	9	I/O	ESD protected channel <sup>(1)</sup>
D3-	8	I/O	ESD protected channel <sup>(1)</sup>
GND	5	Ground	Ground; Connect to ground
GND	10		
NC	1	—	Not connected; Used for optional straight-through routing. Can be left floating or grounded
NC	2		
NC	3		
NC	4		
NC	6		
NC	7		

(1) Place as close to the connector as possible.

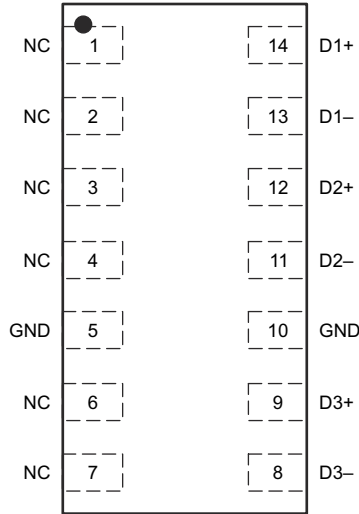
## 6 Specifications

### Absolute Maximum Ratings

over operating free-air temperature range (unless otherwise noted) <sup>(1)</sup>

		MIN	MAX	UNIT
Electrical Fast Transient (2) (3)	IEC 61000-4-4 (5/50ns)		80	A
Peak Pulse (2) (3)	IEC 61000-4-5 Current (8/20us)		2.5	A
	IEC 61000-4-5 Power (8/20us)		40	W
T <sub>A</sub>	Ambient Operating Temperature	-40	125	°C
T <sub>stg</sub>	Storage Temperature	-65	155	°C

- (1) Stresses beyond those listed under Absolute Maximum Ratings may cause permanent damage to the device. These are stress ratings only, which do not imply functional operation of the device at these or any other conditions beyond those indicated under Recommended Operating Conditions. Exposure to absolute-maximum-rated conditions for extended periods may affect device reliability.
- (2) Voltages are with respect to GND unless otherwise noted.
- (3) Measured at 25°C

### 6.1 ESD Ratings—JEDEC Specification

			VALUE	UNIT
V <sub>(ESD)</sub>	Electrostatic discharge – DPY, DQA, and RVZ	Human body model (HBM), per ANSI/ESDA/ JEDEC JS-001 <sup>(1)</sup>	±4000	V
		Charged device model (CDM), per JEDEC specification JESD22-C101 <sup>(2)</sup>	±1500	V
V <sub>(ESD)</sub>	Electrostatic discharge – DYA	Human body model (HBM), per ANSI/ESDA/ JEDEC JS-001	±2500	V
		Charged device model (CDM), per JEDEC specification JS-002	±1000	V

- (1) JEDEC document JEP155 states that 500-V HBM allows safe manufacturing with a standard ESD control process. Manufacturing with less than 500-V HBM is possible with the necessary precautions. Pins listed as ±4000 V may actually have higher performance.
- (2) JEDEC document JEP157 states that 250-V CDM allows safe manufacturing with a standard ESD control process. Manufacturing with less than 250-V CDM is possible with the necessary precautions. Pins listed as ±1500 V may actually have higher performance.

### 6.2 ESD Ratings—IEC Specification

			VALUE	UNIT
V <sub>(ESD)</sub>	Electrostatic discharge	IEC 61000-4-2 contact discharge	±12000	V
		IEC 61000-4-2 air-gap discharge	±15000	

### Recommended Operating Conditions

over operating free-air temperature range (unless otherwise noted)

		MIN	NOM	MAX	UNIT
V <sub>IO</sub>	Input pin voltage	0		5.5	V
T <sub>A</sub>	Operating free-air temperature	-40		125	°C

### 6.3 Thermal Information

THERMAL METRIC <sup>(1)</sup>		TPD1E05U06		TPD4E05U06	TPD6E05U06	UNIT
		DPY (X1SON)	DYA (SOD523)	DQA (USON)	RVZ (USON)	
		2 PINS	2 PINS	10 PINS	14 PINS	
R <sub>θJA</sub>	Junction-to-ambient thermal resistance	697.3	772.1	327	197.9	°C/W
R <sub>θJC(top)</sub>	Junction-to-case (top) thermal resistance	471	444.6	189.5	119.1	°C/W
R <sub>θJB</sub>	Junction-to-board thermal resistance	575.9	540.4	257.7	92.6	°C/W
Ψ <sub>JT</sub>	Junction-to-top characterization parameter	175.7	159.9	60.9	22	°C/W
Ψ <sub>JB</sub>	Junction-to-board characterization parameter	575.1	533.9	257	91.6	°C/W

(1) For more information about traditional and new thermal metrics, see the [Semiconductor and IC Package Thermal Metrics](#) application report.

### 6.4 Electrical Characteristics

over operating free-air temperature range (unless otherwise noted)

PARAMETER		TEST CONDITION	MIN	TYP	MAX	UNIT
<b>INPUT - OUTPUT RESISTANCE</b>						
V <sub>RWM</sub>	Reverse stand-off voltage	I <sub>IO</sub> < 10 μA			5.5	V
V <sub>BR</sub>	Break-down voltage	I <sub>IO</sub> = 1 mA	6.5		8.5	V
V <sub>Clamp</sub>	Clamp voltage	I <sub>PP</sub> = 1 A, TLP, from I/O to GND <sup>(1)</sup>		10		V
		I <sub>PP</sub> = 5 A, TLP, from I/O to GND <sup>(1)</sup>		14		
		I <sub>PP</sub> = 1 A, TLP, from GND to I/O <sup>(1)</sup>		3		
		I <sub>PP</sub> = 5 A, TLP, from GND to I/O <sup>(1)</sup>		7		
I <sub>LEAK</sub>	Leakage current	V <sub>IO</sub> = 2.5 V		0.01	10	nA
R <sub>DYN</sub>	Dynamic resistance	DPY package	I/O to GND <sup>(2)</sup>		0.8	Ω
			GND to I/O <sup>(2)</sup>		0.8	
		DYA package	I/O to GND <sup>(2)</sup>		0.8	
			GND to I/O <sup>(2)</sup>		0.7	
		DQA package	I/O to GND <sup>(2)</sup>		0.8	
			GND to I/O <sup>(2)</sup>		0.8	
		RVZ package	I/O to GND <sup>(2)</sup>		0.8	
			GND to I/O <sup>(2)</sup>		0.8	
<b>CAPACITANCE</b>						
C <sub>L</sub>	Line capacitance <sup>(3)</sup>	V <sub>IO</sub> = 2.5 V; f = 1 MHz, I/O to GND	TPD1E05U06 DPY package		0.42	pF
			TPD1E05U06 DYA package		0.42	
			TPD4E05U06 DQA package		0.5	
			TPD6E05U06 RVZ package		0.47	
Δ C <sub>IO-TO-GND</sub>	Variation of input capacitance	GND Pin = 0 V, f = 1 MHz, VBIAS = 2.5 V, Channel x pin to GND – channel y pin to GND		0.05	0.07	pF

## 6.4 Electrical Characteristics (continued)

over operating free-air temperature range (unless otherwise noted)

PARAMETER		TEST CONDITION	MIN	TYP	MAX	UNIT
C <sub>CROS</sub> s	Channel to channel input capacitance	GND Pin = 0 V, f = 1 MHz, VBIAS = 2.5 V, between channel pins		0.01	0.06	pF

- (1) Transition line pulse with 100 ns width, 200 ps rise time.
- (2) Extraction of R<sub>DYN</sub> using least squares fit of TLP characteristics between I = 10 A and I = 20 A.
- (3) Capacitance data is taken at 25°C.



## 6.5 Typical Characteristics



图 6-1. DC Voltage Sweep I-V Curve



图 6-2. Surge Curve ( $t_p = 8/20 \mu s$ ), Pin IO to GND

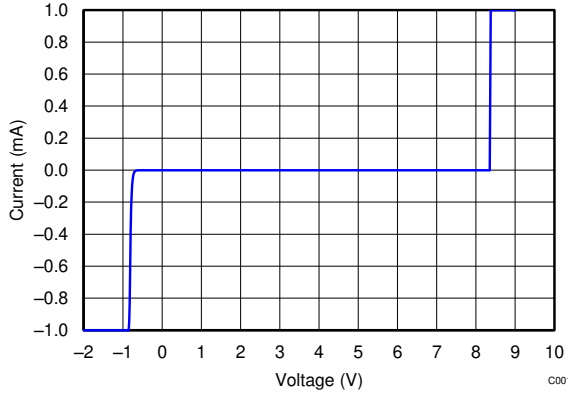

图 6-3. Positive TLP Plot IO to GND

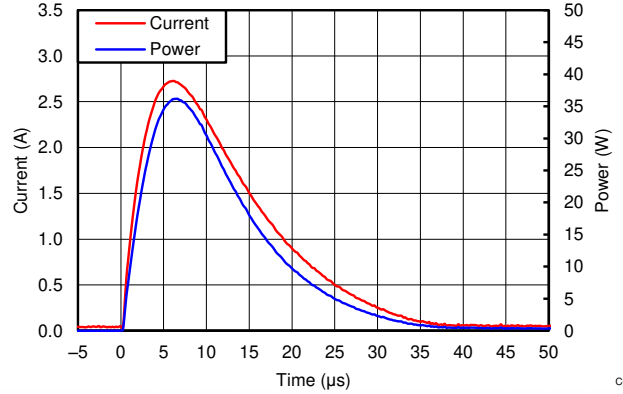

图 6-4. Negative TLP Plot IO to GND

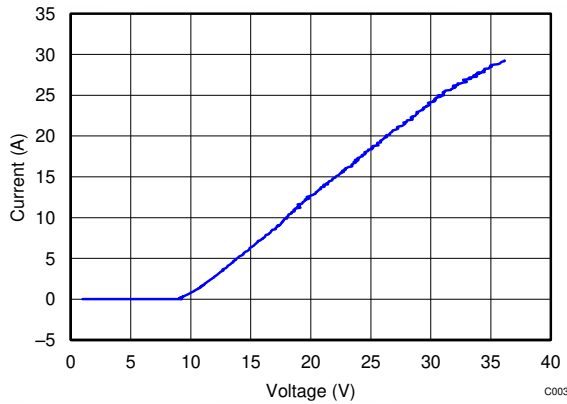

图 6-5. Leakage vs Temperature

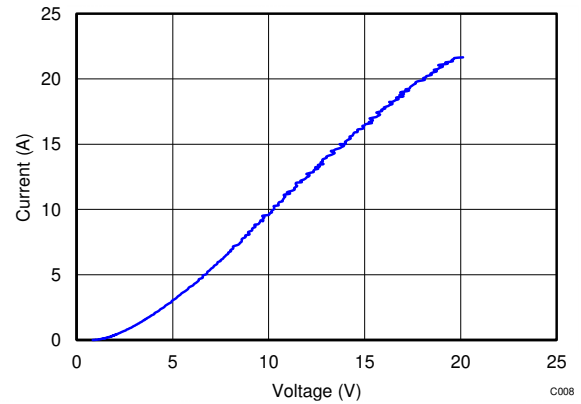

图 6-6. 8-kV IEC Waveform

## 6.5 Typical Characteristics (continued)

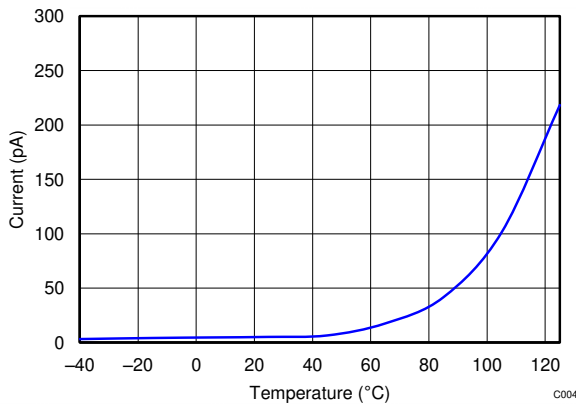

图 6-7. -8-kV IEC Waveform

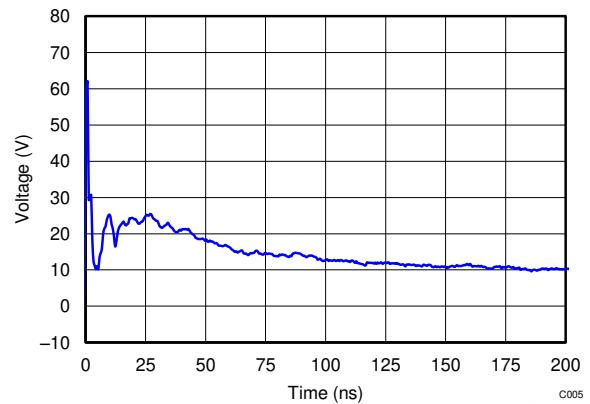

图 6-8. TPD1E05U06 Insertion Loss

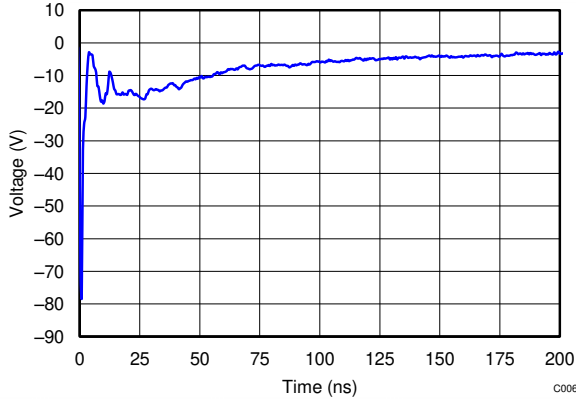

图 6-9. TPD4E05U06 Insertion Loss

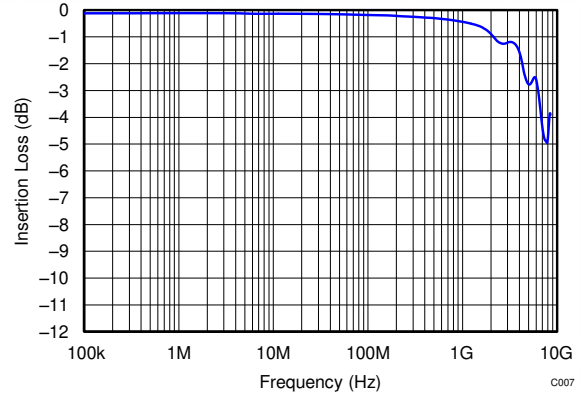

图 6-10. TPD6E05U06 Insertion Loss

## 7 Detailed Description

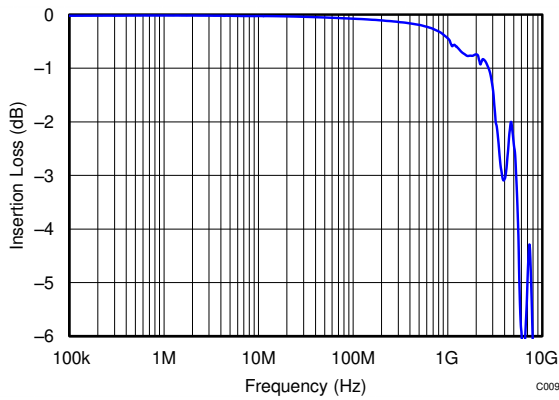
### 7.1 Overview

The TPDxE05U06 is a family of unidirectional Transient Voltage Suppressor (TVS) based Electrostatic Discharge (ESD) protection diodes with ultra-low capacitance. Each device can dissipate ESD strikes above the maximum level specified by the IEC 61000-4-2 international standard. The TPDxE05U06s ultra-low loading capacitance makes it ideal for protecting any high-speed signal pins.

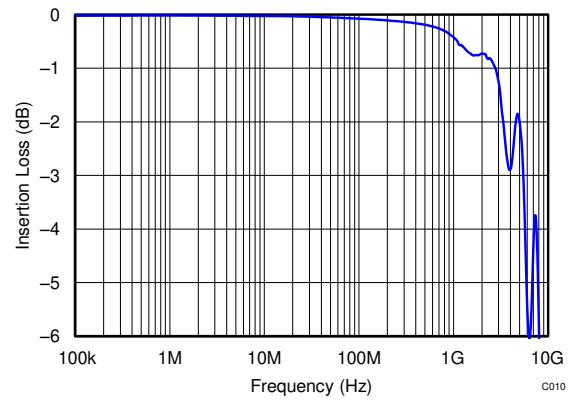
### 7.2 Functional Block Diagram

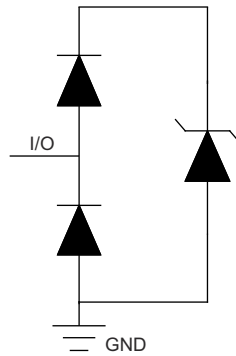

 7-1. TPD1E05U06 Block Diagram

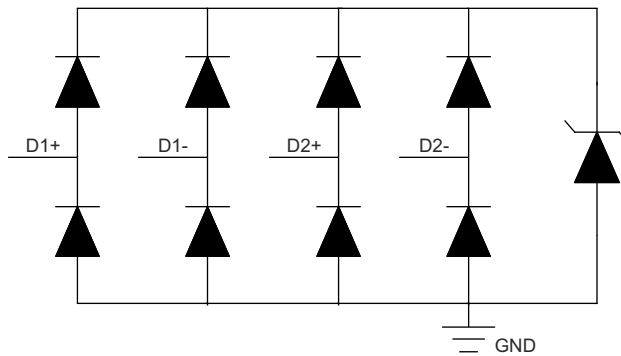

 7-2. TPD4E05U06 Block Diagram

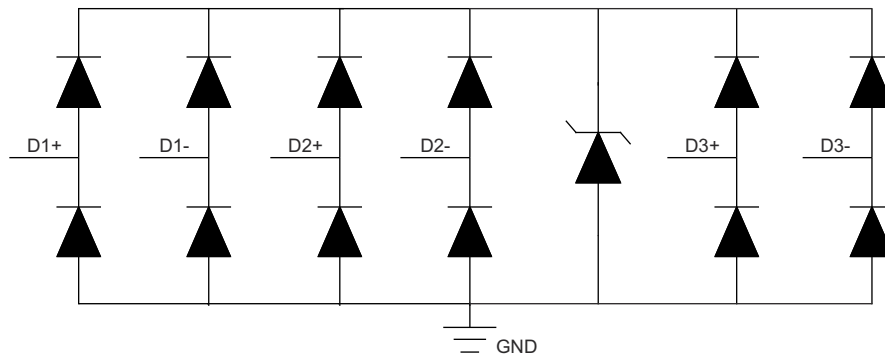

 7-3. TPD6E05U06 Block Diagram

## 7.3 Feature Description

The TPDxE05U06 is a family of unidirectional Transient Voltage Suppressor (TVS) Electrostatic Discharge (ESD) protection diodes with ultra-low capacitance. Each device can dissipate ESD strikes above the maximum level specified by the IEC 61000-4-2 international standard. The TPDxE05U06s ultra-low loading capacitance makes it ideal for protecting any high-speed signal pins.

### 7.3.1 ±15-kV IEC61000-4-2 Level 4 ESD Protection

The I/O pins can withstand ESD events up to ±12-kV contact and ±15-kV air. An ESD-surge clamp diverts the current to ground.

### 7.3.2 IEC61000-4-4 EFT Protection

The I/O pins can withstand an electrical fast transient burst of up to 80 A (5/50 ns waveform, 4 kV with 50-Ω impedance). An ESD-surge clamp diverts the current to ground. This has been validated on the TPD4E05U06 only.

### 7.3.3 IEC61000-4-5 Surge Protection

The I/O pins can withstand surge events up to 2.5 A and 40 W (8/20 μs waveform). An ESD-surge clamp diverts this current to ground.

### 7.3.4 I/O Capacitance

The capacitance between each I/O pin to ground is 0.42 pF (TPD1E05U06), 0.5 pF (TPD4E05U06) or 0.47 pF (TPD6E05U06). These devices support data rates up to 6 Gbps.

### 7.3.5 DC Breakdown Voltage

The DC breakdown voltage of each I/O pin is a minimum of 6.5 V. This ensures that sensitive equipment is protected from surges above the reverse standoff voltage of 5.5 V.

### 7.3.6 Ultra-Low Leakage Current

The I/O pins feature an ultra-low leakage current of 10 nA (maximum) with a bias of 2.5 V.

### 7.3.7 Low ESD Clamping Voltage

The I/O pins feature an ESD clamp that is capable of clamping the voltage to 10 V ( $I_{PP} = 1$  A).

### 7.3.8 Industrial Temperature Range

This device features an industrial operating range of –40°C to +125°C.

### 7.3.9 Easy Flow-Through Routing

The layout of this device makes it simple and easy to add protection to an existing layout. The packages offers flow-through routing, requiring minimal modification to an existing layout.

## 7.4 Device Functional Modes

The TPDxE05U06 is a passive integrated circuit that triggers when voltages are above VBR or below the lower diodes  $V_f$  (–0.6 V). During ESD events, voltages as high as ±15 kV (air) can be directed to ground via the internal diode network. When the voltages on the protected line fall below the trigger levels of TPDxE05U06 (usually within 10s of nano-seconds) the device reverts to passive.

## 8 Application and Implementation

### Note

以下のアプリケーション情報は、TI の製品仕様に含まれるものではなく、TI ではその正確性または完全性を保証いたしません。個々の目的に対する製品の適合性については、お客様の責任で判断していただくことになります。お客様は自身の設計実装を検証しテストすることで、システムの機能を確認する必要があります。

### 8.1 Application Information

The TPDxE05U06 is a diode type TVS which is typically used to provide a path to ground for dissipating ESD events on hi-speed signal lines between a human interface connector and a system. As the current from ESD passes through the TVS, only a small voltage drop is present across the diode. This is the voltage presented to the protected IC. The low  $R_{DYN}$  of the triggered TVS holds this voltage,  $V_{CLAMP}$ , to a safe level for the protected IC.

### 8.2 Typical Applications

#### 8.2.1 HDMI 2.0 Application

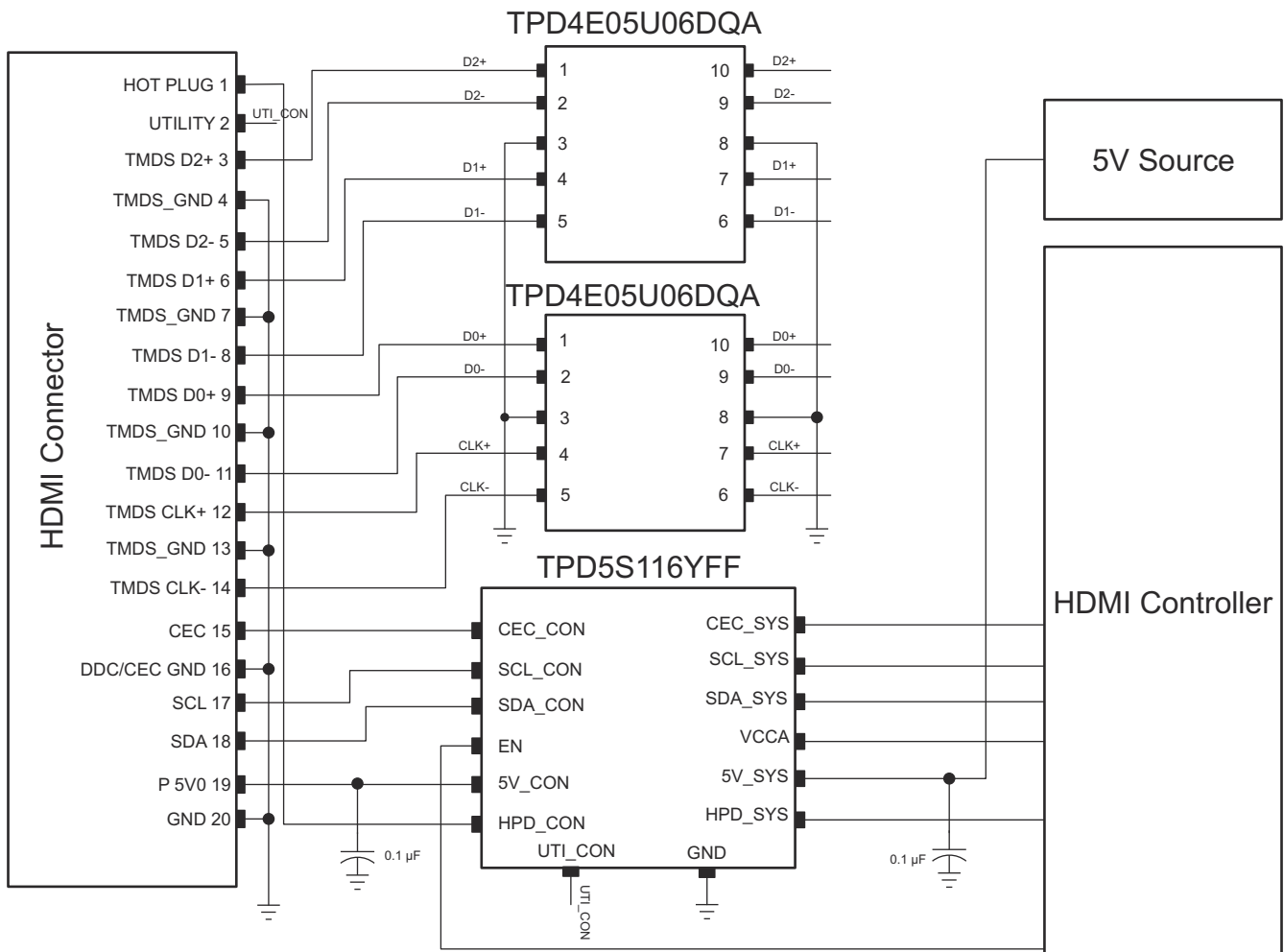

☒ 8-1. HDMI 2.0 Schematic

### 8.2.1.1 Design Requirements

For this design example, the two TPD4E05U06 devices, and a TPD5S116 are being used in an HDMI 2.0 application. This provides a complete port protection scheme.

Given the HDMI 2.0 application, the parameters listed in 表 8-1 are known.

表 8-1. Design Parameters

DESIGN PARAMETER	VALUE
Signal range on pins 1, 2, 4, or 5	0 V to 5 V
Operating frequency	3 GHz

### 8.2.1.2 Detailed Design Procedure

#### 8.2.1.2.1 Signal Range on Pin 1, 2, 4, or 5

The TPD4E05U06 has 4 identical protection channels for signal lines. The symmetry of the device provides flexibility when selecting which of the 4 I/O channels is going to protect which signal lines. Any I/O supports a signal range of 0 to 5.5 V.

### 8.2.1.3 Application Curves



图 8-2. 3.4-Gbps HDMI 1.4 TP1 Eye Diagram Unpopulated EVM



图 8-3. 3.4-Gbps HDMI 1.4 TP1 Eye Diagram TPD1E05U06

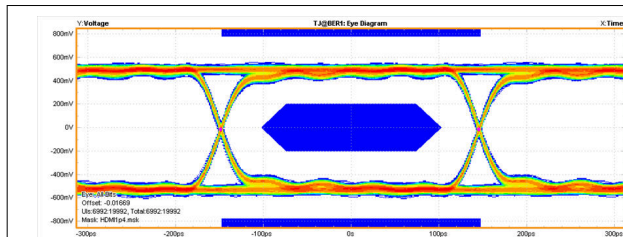

图 8-4. 3.4-Gbps HDMI 1.4 TP1 Eye Diagram TPD4E05U06

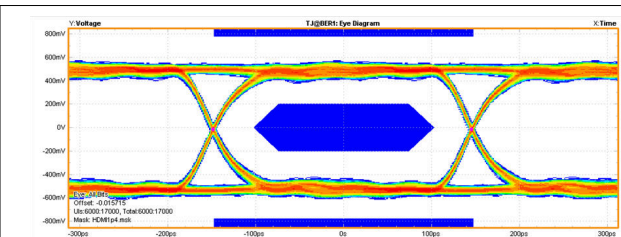

图 8-5. 3.4-Gbps HDMI 1.4 TP1 Eye Diagram TPD6E05U06

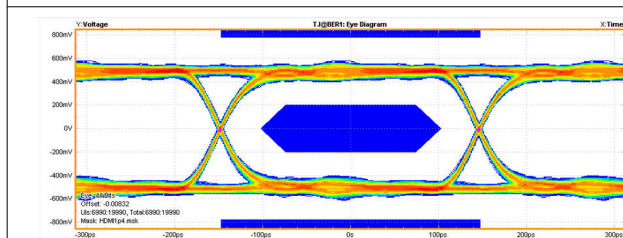

图 8-6. 6-Gbps HDMI 2.0 (TP1) Eye Diagram Unpopulated EVM

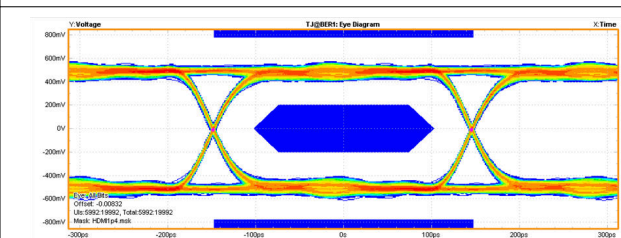

图 8-7. 6-Gbps HDMI 2.0 (TP1) Eye Diagram TPD1E05U06

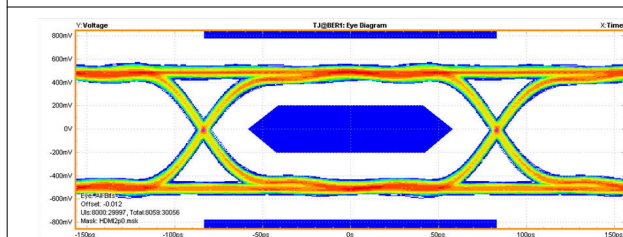

**图 8-8. 6-Gbps HDMI 2.0 (TP1) Eye Diagram TPD4E05U06**

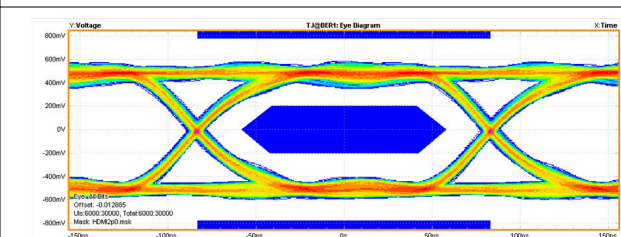
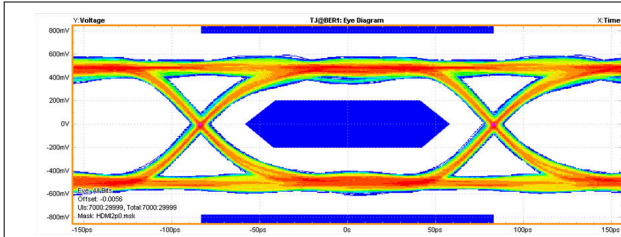
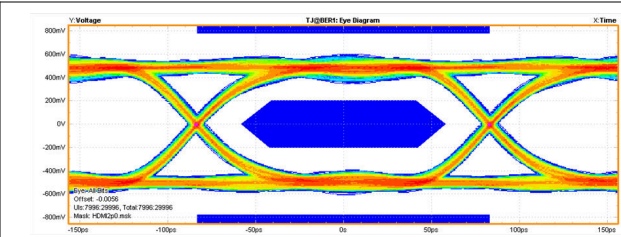

**图 8-9. 6-Gbps HDMI 2.0 (TP1) Eye Diagram TPD6E05U06**

### 8.2.2 HDMI 2.0 Application

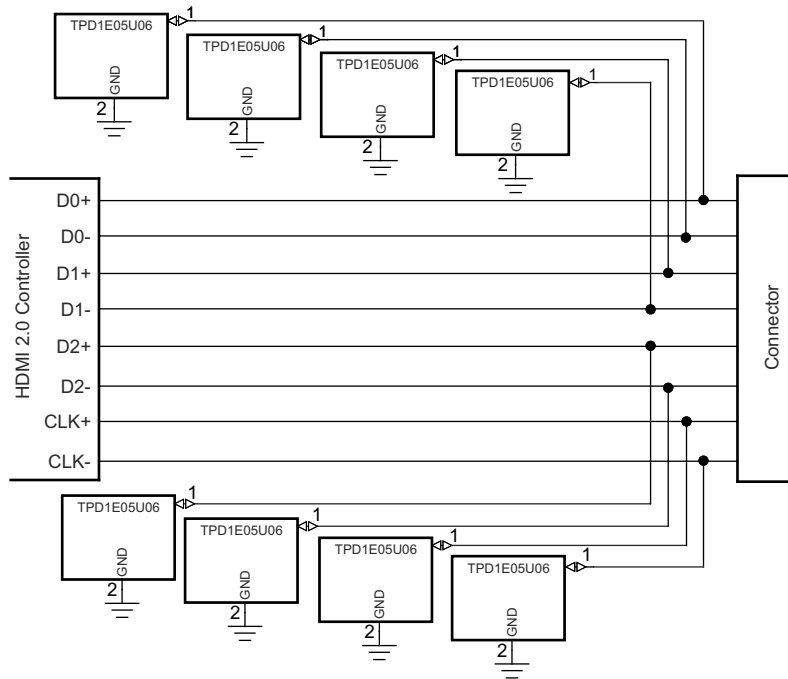

**图 8-10. HDMI 2.0 Schematic**

### 8.2.2.1 Design Requirements

For this design example, the TPD1E05U06 and the TPD5S116 are used to protect the data pairs and control lines of the HDMI 2.0 connection. This provides full HDMI 2.0 port protection.

Given the HDMI 2.0 application, the following parameters in [表 8-2](#) are known.

**表 8-2. Design Parameters**

DESIGN PARAMETER	VALUE
Signal range on data lines	0 V to 5 V
Operating frequency	3 GHz

### 8.2.2.2 Detailed Design Procedure

#### 8.2.2.2.1 Signal Range

The TPD1E05U06 has 1 protection channel for signal lines, supporting a signal range of 0 V to 5.5 V.

#### 8.2.2.2.2 Operating Frequency

The TPD1E05U06 has 0.42 pF of capacitance, which supports HDMI 2.0 data rates.

#### 8.2.2.3 Application Curves

Refer to the [セクション 8.2.1.3](#) section.

## 9 Power Supply Recommendations

This device is a passive ESD protection device and there is no need to power it. Care must be taken to make sure that the maximum voltage specifications for each line are not violated.



## 10 Layout

### 10.1 Layout Guidelines

- The optimum placement is as close to the connector as possible.
  - EMI during an ESD event can couple from the trace being struck to other nearby unprotected traces, resulting in early system failures.
  - The PCB designer needs to minimize the possibility of EMI coupling by keeping any unprotected traces away from the protected traces which are between the TVS and the connector.
- Route the protected traces as straight as possible.
- Eliminate any sharp corners on the protected traces between the TVS and the connector by using rounded corners with the largest radii possible.
  - Electric fields tend to build up on corners, increasing EMI coupling.

### 10.2 Layout Example

#### 10.2.1 TPD4E05U06 Layout Example

This application is typical of an HDMI 1.4 layout.

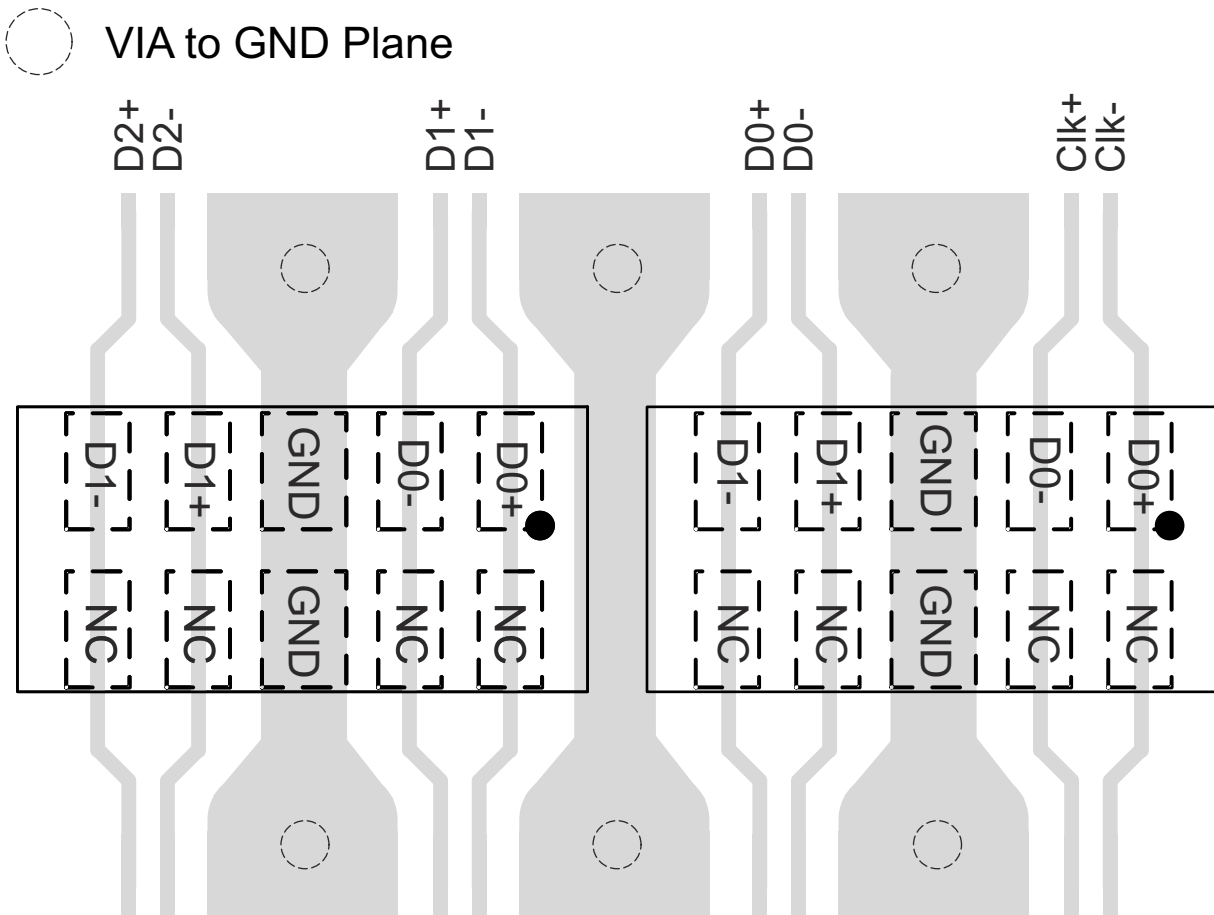

☒ 10-1. TPD4E05U06 Layout

### 10.2.2 TPD1E05U06 Layout Example

This application is typical of an HDMI 2.0 layout.

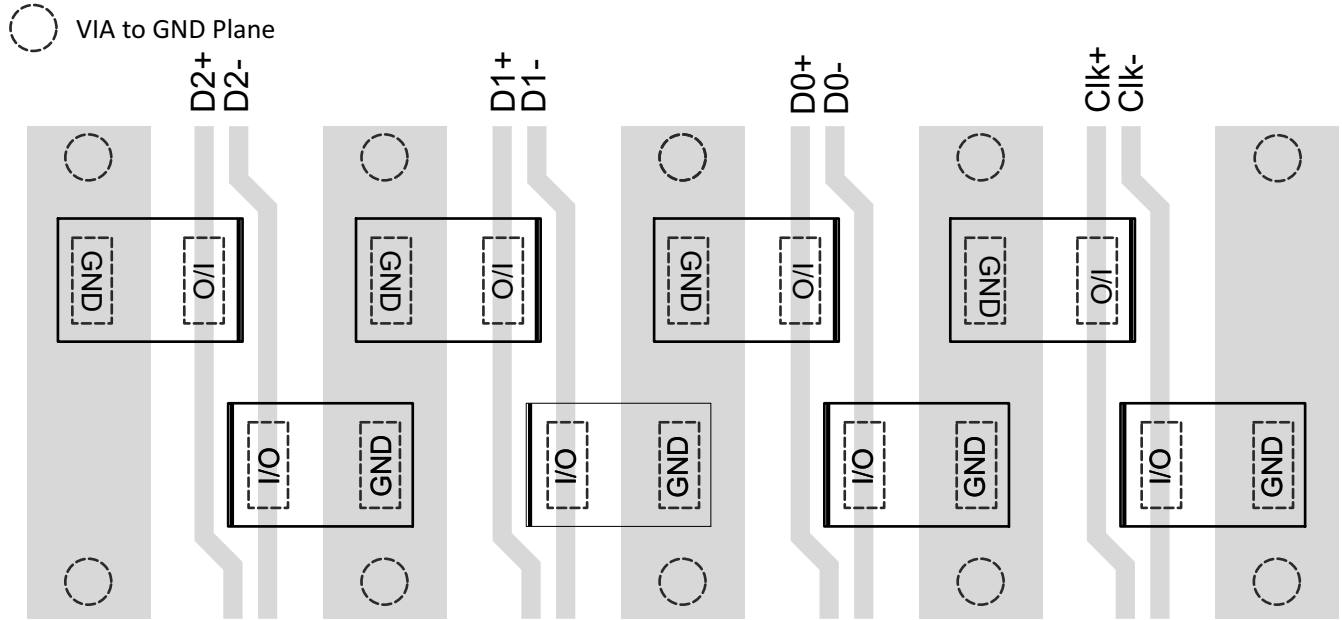

✕ 10-2. TPD1E05U06 Layout

## 11 Device and Documentation Support

### 11.1 Documentation Support

#### 11.1.1 Related Documentation

For related documentation, see the following:

- Texas Instruments, [Reading and Understanding an ESD Protection data sheet](#)
- Texas Instruments, [ESD Layout Guide application reports](#)
- Texas Instruments, [TPD6E05U06RVZ EVM user's guide](#)
- Texas Instruments, [Picking ESD Diodes for Ultra High-Speed Data Lines application reports](#)
- Texas Instruments, [ESD PROTECTION DIODES EVM user's guide](#)
- Texas Instruments, [TPD1E05U06DPY EVM user's guide](#)
- Texas Instruments, [TPD4E05U06DQA EVM user's guide](#)
- Texas Instruments, [Generic ESD Evaluation Module user's guide](#)

#### 11.2 Receiving Notification of Documentation Updates

To receive notification of documentation updates, navigate to the device product folder on [ti.com](http://ti.com). Click on *Subscribe to updates* to register and receive a weekly digest of any product information that has changed. For change details, review the revision history included in any revised document.

#### 11.3 サポート・リソース

TI E2E™ サポート・フォーラムは、エンジニアが検証済みの回答と設計に関するヒントをエキスパートから迅速かつ直接得ることができる場所です。既存の回答を検索したり、独自の質問をしたりすることで、設計に必要な支援を迅速に得ることができます。

リンクされているコンテンツは、該当する貢献者により、現状のまま提供されるものです。これらは TI の仕様を構成するものではなく、必ずしも TI の見解を反映したものではありません。TI の [使用条件](#) を参照してください。

#### 11.4 Trademarks

TI E2E™ is a trademark of Texas Instruments.

PCI-express® and PCI-Express® are registered trademarks of PCI-SIG .

V-by-One® are registered trademarks of Thine Electronics, Inc.

すべての商標は、それぞれの所有者に帰属します。

#### 11.5 Electrostatic Discharge Caution



This integrated circuit can be damaged by ESD. Texas Instruments recommends that all integrated circuits be handled with appropriate precautions. Failure to observe proper handling and installation procedures can cause damage.

ESD damage can range from subtle performance degradation to complete device failure. Precision integrated circuits may be more susceptible to damage because very small parametric changes could cause the device not to meet its published specifications.

#### 11.6 Glossary

[TI Glossary](#) This glossary lists and explains terms, acronyms, and definitions.

## 12 Mechanical, Packaging, and Orderable Information

The following pages include mechanical, packaging, and orderable information. This information is the most current data available for the designated devices. This data is subject to change without notice and revision of this document. For browser-based versions of this data sheet, refer to the left-hand navigation.

**PACKAGING INFORMATION**

Orderable Device	Status (1)	Package Type	Package Drawing	Pins	Package Qty	Eco Plan (2)	Lead finish/ Ball material (6)	MSL Peak Temp (3)	Op Temp (°C)	Device Marking (4/5)	Samples
TPD1E05U06DPYR	ACTIVE	X1SON	DPY	2	10000	RoHS & Green	NIPDAU	Level-1-260C-UNLIM	-40 to 125	(BK, C1, C6) C2	<a href="#">Samples</a>
TPD1E05U06DPYT	ACTIVE	X1SON	DPY	2	250	RoHS & Green	NIPDAU	Level-1-260C-UNLIM	-40 to 125	(BK, C1, C6) C2	<a href="#">Samples</a>
TPD1E05U06DYAR	ACTIVE	SOT-5X3	DYA	2	3000	RoHS & Green	SN	Level-3-260C-168 HR	-40 to 125	1KS	<a href="#">Samples</a>
TPD4E05U06DQAR	ACTIVE	USON	DQA	10	3000	RoHS & Green	NIPDAU	Level-1-260C-UNLIM	-40 to 125	(BLG, BRG, DQA) BRY	<a href="#">Samples</a>
TPD6E05U06RVZR	ACTIVE	USON	RVZ	14	3000	RoHS & Green	NIPDAU	Level-1-260C-UNLIM	-40 to 125	(BV, BVY)	<a href="#">Samples</a>

(1) The marketing status values are defined as follows:

**ACTIVE:** Product device recommended for new designs.

**LIFEBUY:** TI has announced that the device will be discontinued, and a lifetime-buy period is in effect.

**NRND:** Not recommended for new designs. Device is in production to support existing customers, but TI does not recommend using this part in a new design.

**PREVIEW:** Device has been announced but is not in production. Samples may or may not be available.

**OBSOLETE:** TI has discontinued the production of the device.

(2) **RoHS:** TI defines "RoHS" to mean semiconductor products that are compliant with the current EU RoHS requirements for all 10 RoHS substances, including the requirement that RoHS substance do not exceed 0.1% by weight in homogeneous materials. Where designed to be soldered at high temperatures, "RoHS" products are suitable for use in specified lead-free processes. TI may reference these types of products as "Pb-Free".

**RoHS Exempt:** TI defines "RoHS Exempt" to mean products that contain lead but are compliant with EU RoHS pursuant to a specific EU RoHS exemption.

**Green:** TI defines "Green" to mean the content of Chlorine (Cl) and Bromine (Br) based flame retardants meet JS709B low halogen requirements of <=1000ppm threshold. Antimony trioxide based flame retardants must also meet the <=1000ppm threshold requirement.

(3) MSL, Peak Temp. - The Moisture Sensitivity Level rating according to the JEDEC industry standard classifications, and peak solder temperature.

(4) There may be additional marking, which relates to the logo, the lot trace code information, or the environmental category on the device.

(5) Multiple Device Markings will be inside parentheses. Only one Device Marking contained in parentheses and separated by a "-" will appear on a device. If a line is indented then it is a continuation of the previous line and the two combined represent the entire Device Marking for that device.

(6) Lead finish/Ball material - Orderable Devices may have multiple material finish options. Finish options are separated by a vertical ruled line. Lead finish/Ball material values may wrap to two lines if the finish value exceeds the maximum column width.

**Important Information and Disclaimer:** The information provided on this page represents TI's knowledge and belief as of the date that it is provided. TI bases its knowledge and belief on information provided by third parties, and makes no representation or warranty as to the accuracy of such information. Efforts are underway to better integrate information from third parties. TI has taken and continues to take reasonable steps to provide representative and accurate information but may not have conducted destructive testing or chemical analysis on incoming materials and chemicals. TI and TI suppliers consider certain information to be proprietary, and thus CAS numbers and other limited information may not be available for release.

In no event shall TI's liability arising out of such information exceed the total purchase price of the TI part(s) at issue in this document sold by TI to Customer on an annual basis.

**OTHER QUALIFIED VERSIONS OF TPD1E05U06, TPD4E05U06 :**

- Automotive : [TPD1E05U06-Q1](#), [TPD4E05U06-Q1](#)

NOTE: Qualified Version Definitions:

- Automotive - Q100 devices qualified for high-reliability automotive applications targeting zero defects

**TAPE AND REEL INFORMATION**

**QUADRANT ASSIGNMENTS FOR PIN 1 ORIENTATION IN TAPE**

\*All dimensions are nominal

Device	Package Type	Package Drawing	Pins	SPQ	Reel Diameter (mm)	Reel Width W1 (mm)	A0 (mm)	B0 (mm)	K0 (mm)	P1 (mm)	W (mm)	Pin1 Quadrant
TPD1E05U06DPYT	X1SON	DPY	2	250	180.0	9.5	0.66	1.15	0.66	2.0	8.0	Q1
TPD1E05U06DYAR	SOT-5X3	DYA	2	3000	178.0	9.5	0.5	1.94	0.73	2.0	8.0	Q1
TPD4E05U06DQAR	USON	DQA	10	3000	180.0	8.4	1.2	2.7	0.63	4.0	8.0	Q1
TPD6E05U06RVZR	USON	RVZ	14	3000	180.0	13.2	1.65	3.8	0.7	4.0	12.0	Q1
TPD6E05U06RVZR	USON	RVZ	14	3000	178.0	13.5	1.6	3.75	0.7	4.0	12.0	Q1

**TAPE AND REEL BOX DIMENSIONS**

\*All dimensions are nominal

Device	Package Type	Package Drawing	Pins	SPQ	Length (mm)	Width (mm)	Height (mm)
TPD1E05U06DPYT	X1SON	DPY	2	250	184.0	184.0	19.0
TPD1E05U06DYAR	SOT-5X3	DYA	2	3000	210.0	200.0	42.0
TPD4E05U06DQAR	USON	DQA	10	3000	210.0	185.0	35.0
TPD6E05U06RVZR	USON	RVZ	14	3000	184.0	184.0	19.0
TPD6E05U06RVZR	USON	RVZ	14	3000	189.0	185.0	36.0

DPY (R-PX1SON-N2)

PLASTIC SMALL OUTLINE NO-LEAD



4211012/D 08/14

- NOTES:
- A. All linear dimensions are in millimeters. Dimensioning and tolerancing per ASME Y14.5-1994.
  - B. This drawing is subject to change without notice.
  - C. SON (Small Outline No-Lead) package configuration.



DPY0002A

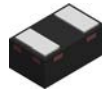

**PACKAGE OUTLINE**  
**X1SON - 0.45 mm max height**

PLASTIC SMALL OUTLINE - NO LEAD

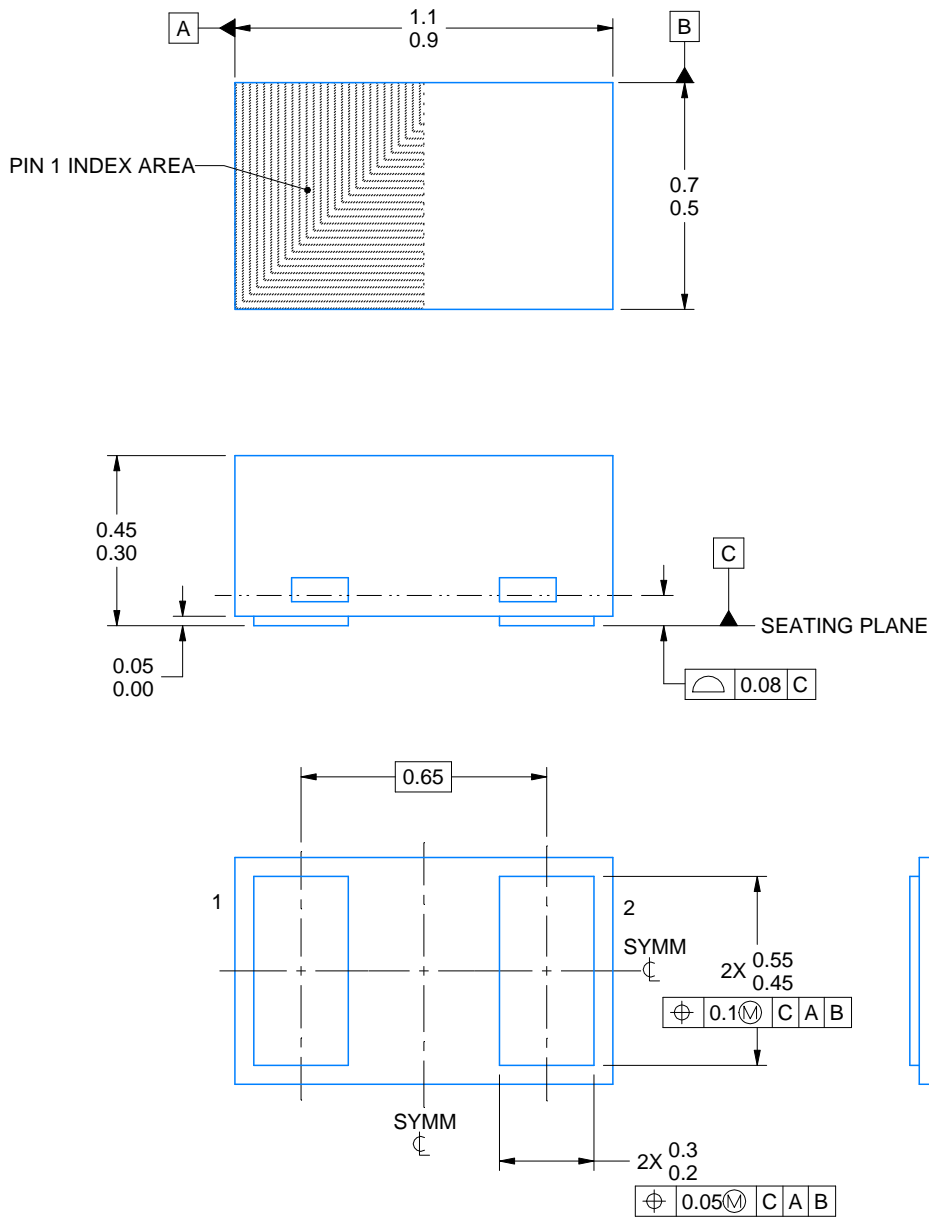

4224561/B 03/2021

NOTES:

1. All linear dimensions are in millimeters. Any dimensions in parenthesis are for reference only. Dimensioning and tolerancing per ASME Y14.5M
2. This drawing is subject to change without notice.

# EXAMPLE BOARD LAYOUT

DPY0002A

X1SON - 0.45 mm max height

PLASTIC SMALL OUTLINE - NO LEAD

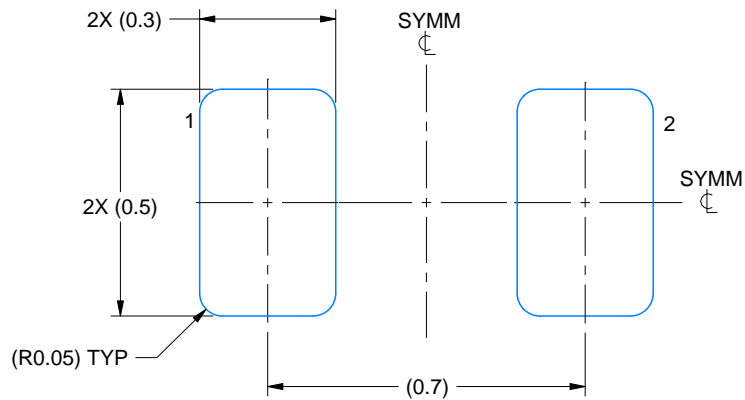

LAND PATTERN EXAMPLE  
EXPOSED METAL SHOWN  
SCALE:60X

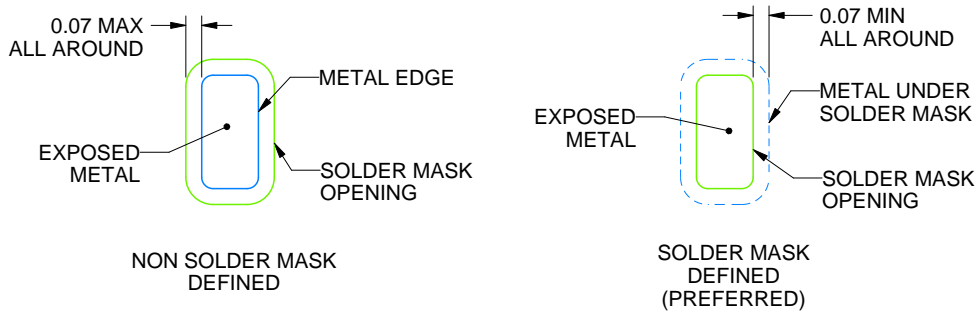

SOLDER MASK DETAILS

4224561/B 03/2021

NOTES: (continued)

3. For more information, see Texas Instruments literature number SLUA271 ([www.ti.com/lit/slue271](http://www.ti.com/lit/slue271)).
4. Vias are optional depending on application, refer to device data sheet. If any vias are implemented, refer to their locations shown on this view. It is recommended that vias under paste be filled, plugged or tented.

# EXAMPLE STENCIL DESIGN

DPY0002A

X1SON - 0.45 mm max height

PLASTIC SMALL OUTLINE - NO LEAD

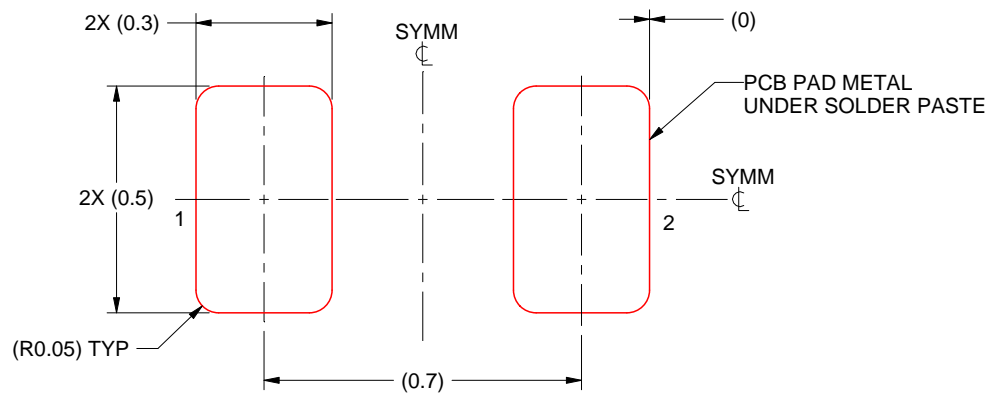

SOLDER PASTE EXAMPLE  
BASED ON 0.1 mm THICK STENCIL  
SCALE:60X

4224561/B 03/2021

NOTES: (continued)

5. Laser cutting apertures with trapezoidal walls and rounded corners may offer better paste release. IPC-7525 may have alternate design recommendations.

RVZ (R-PUSON-N14)

PLASTIC SMALL OUTLINE NO-LEAD

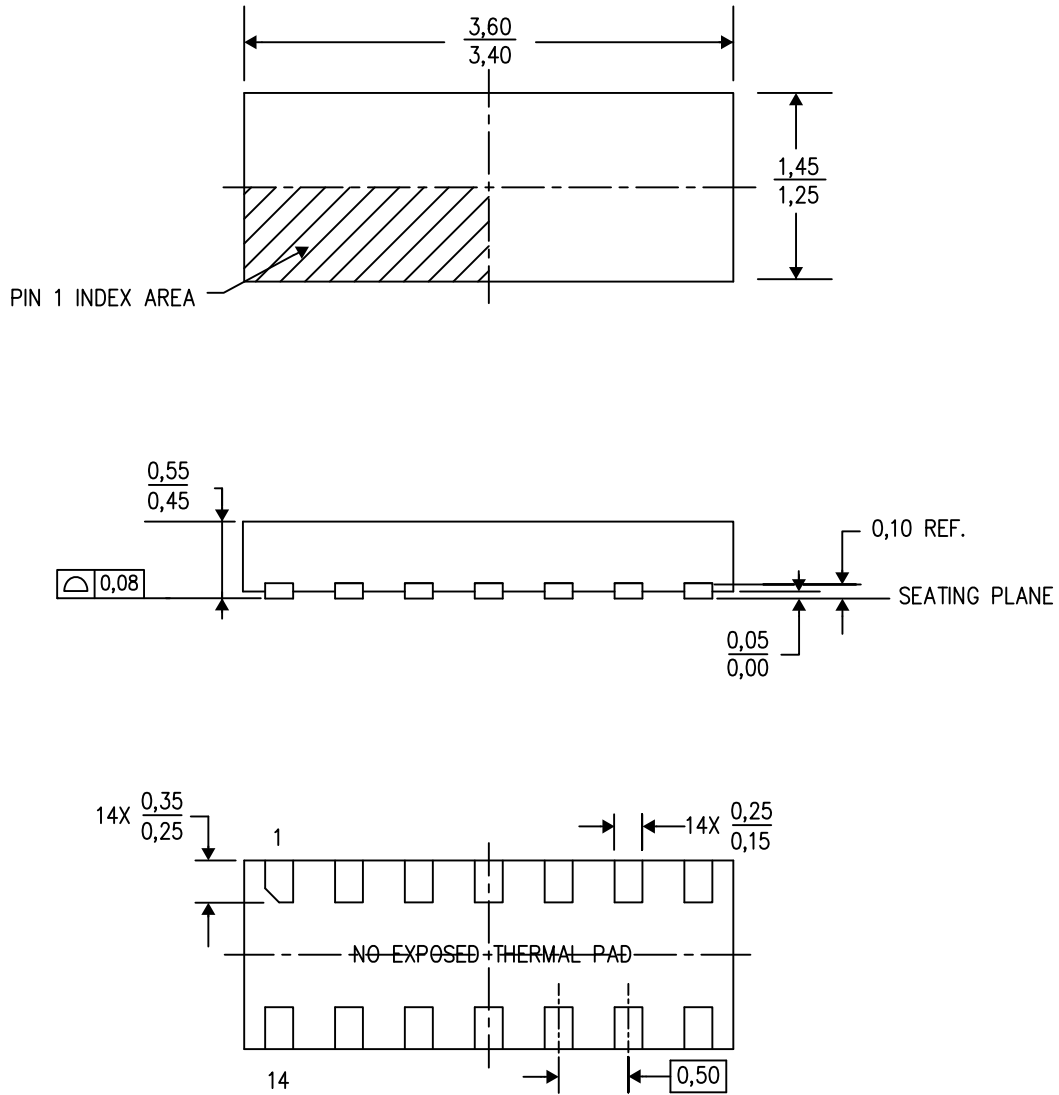

4218112/B 04/14

- NOTES:
- All linear dimensions are in millimeters. Dimensioning and tolerancing per ASME Y14.5M-1994.
  - This drawing is subject to change without notice.
  - QFN (Quad Flatpack No-Lead) package configuration.

RVZ (R-PUSON-N14)

PLASTIC SMALL OUTLINE NO-LEAD

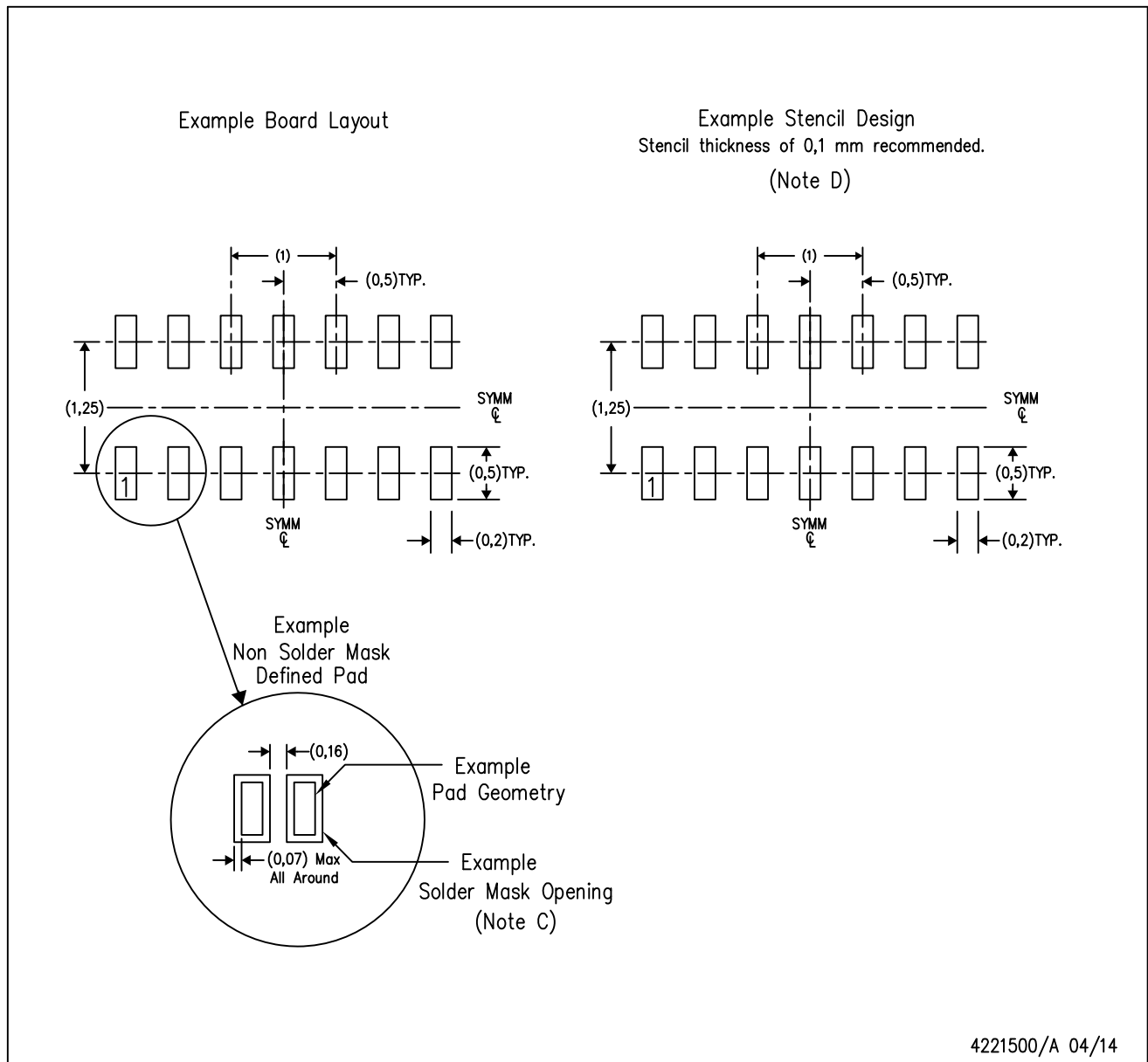

- NOTES:
- A. All linear dimensions are in millimeters.
  - B. This drawing is subject to change without notice.
  - C. Customers should contact their board fabrication site for minimum solder mask web tolerances between signal pads.
  - D. Laser cutting apertures with trapezoidal walls and also rounding corners will offer better paste release. Customers should contact their board assembly site for stencil design recommendations. Refer to IPC 7525 for stencil design considerations.

DYA0002A



# PACKAGE OUTLINE

SOT (SOD-523) - 0.77 mm max height

PLASTIC SMALL OUTLINE

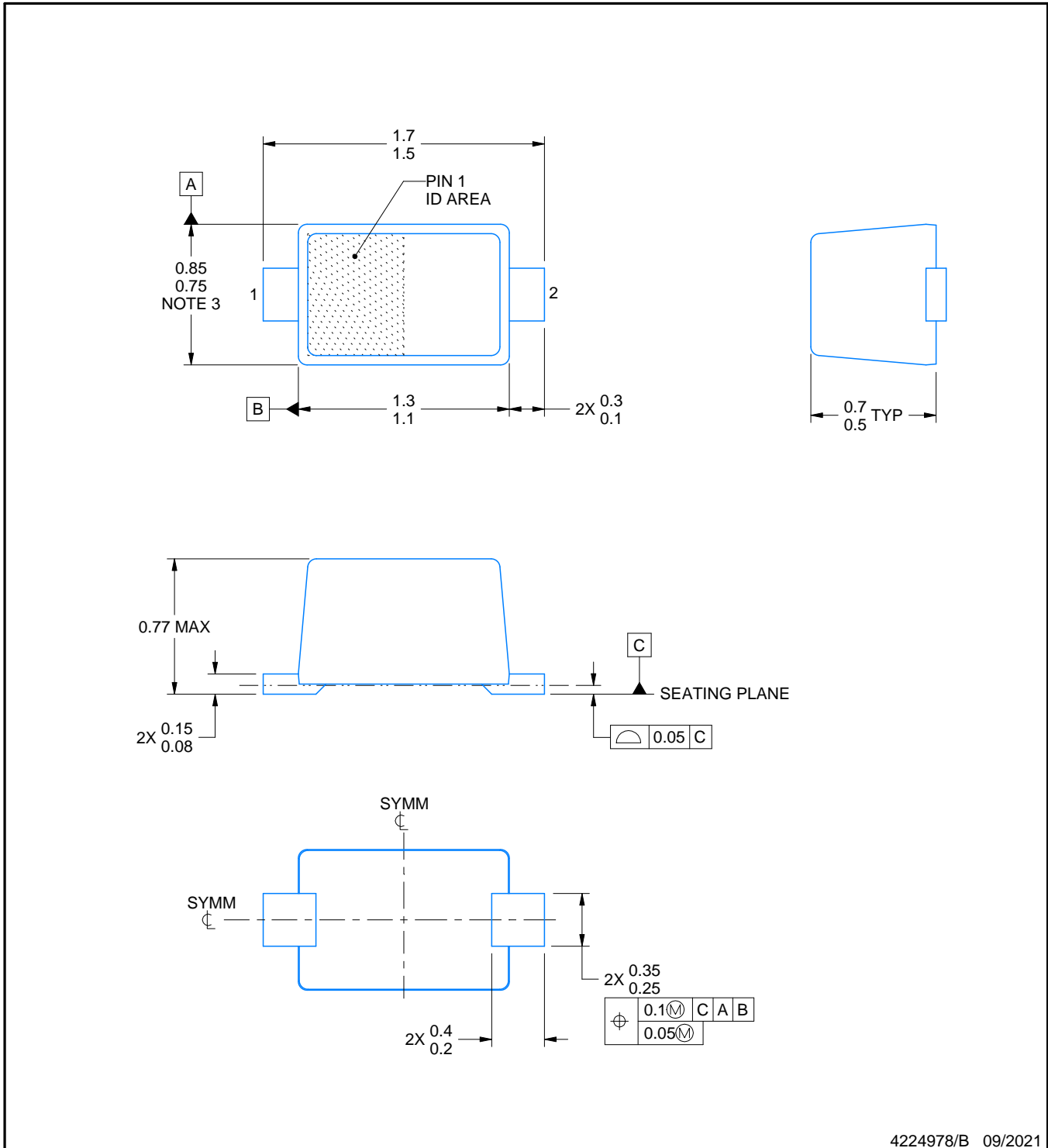

4224978/B 09/2021

## NOTES:

1. All linear dimensions are in millimeters. Any dimensions in parenthesis are for reference only. Dimensioning and tolerancing per ASME Y14.5M.
2. This drawing is subject to change without notice.
3. This dimension does not include mold flash, protrusions, or gate burrs. Mold flash, protrusions, or gate burrs shall not exceed 0.15 mm per side.
4. Reference JEITA SC-79 registration except for package height

# EXAMPLE BOARD LAYOUT

DYA0002A

SOT (SOD-523) - 0.77 mm max height

PLASTIC SMALL OUTLINE

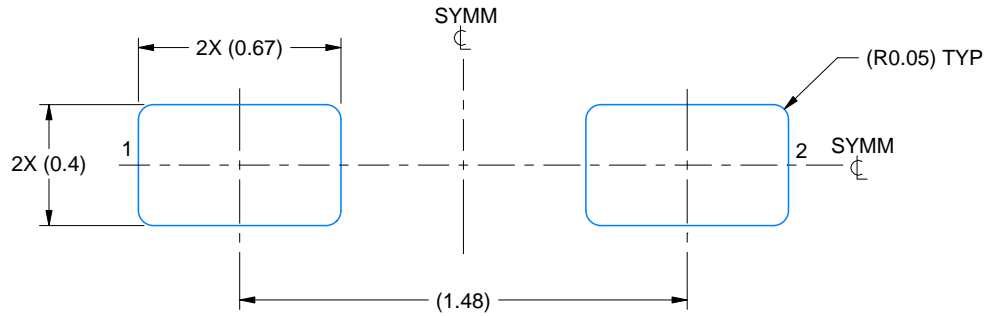

LAND PATTERN EXAMPLE  
SCALE:40X

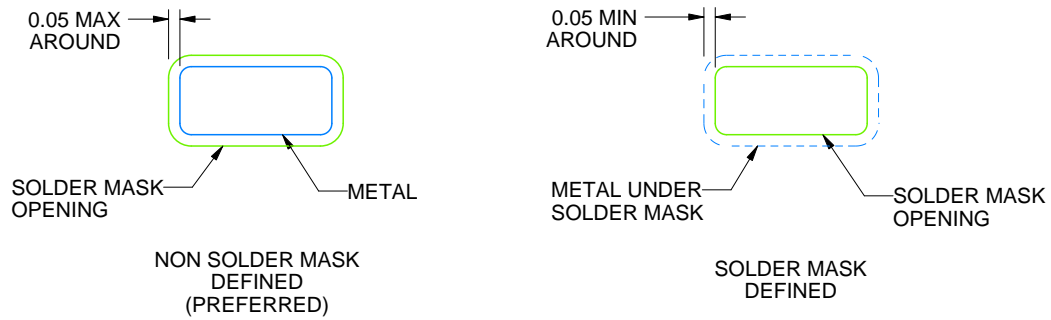

SOLDERMASK DETAILS

4224978/B 09/2021

NOTES: (continued)

- 5. Publication IPC-7351 may have alternate designs.
- 6. Solder mask tolerances between and around signal pads can vary based on board fabrication site.

# EXAMPLE STENCIL DESIGN

DYA0002A

SOT (SOD-523) - 0.77 mm max height

PLASTIC SMALL OUTLINE

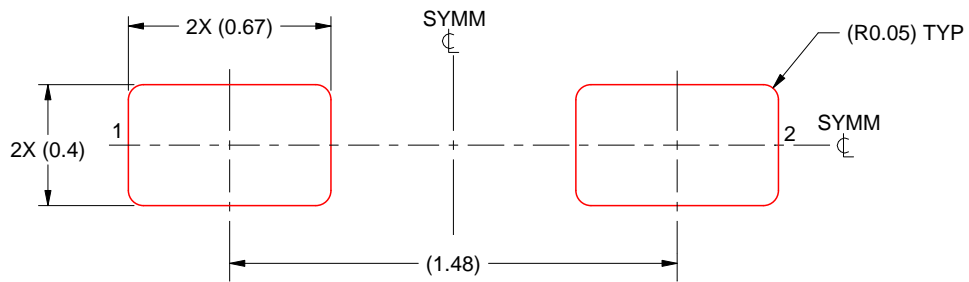

SOLDER PASTE EXAMPLE  
BASED ON 0.1 mm THICK STENCIL  
SCALE:40X

4224978/B 09/2021

NOTES: (continued)

7. Laser cutting apertures with trapezoidal walls and rounded corners may offer better paste release. IPC-7525 may have alternate design recommendations.
8. Board assembly site may have different recommendations for stencil design.



## GENERIC PACKAGE VIEW

**DQA 10**

**USON - 0.55 mm max height**

1 x 2.5, 0.5 mm pitch

PLASTIC SMALL OUTLINE - NO LEAD

This image is a representation of the package family, actual package may vary.  
Refer to the product data sheet for package details.

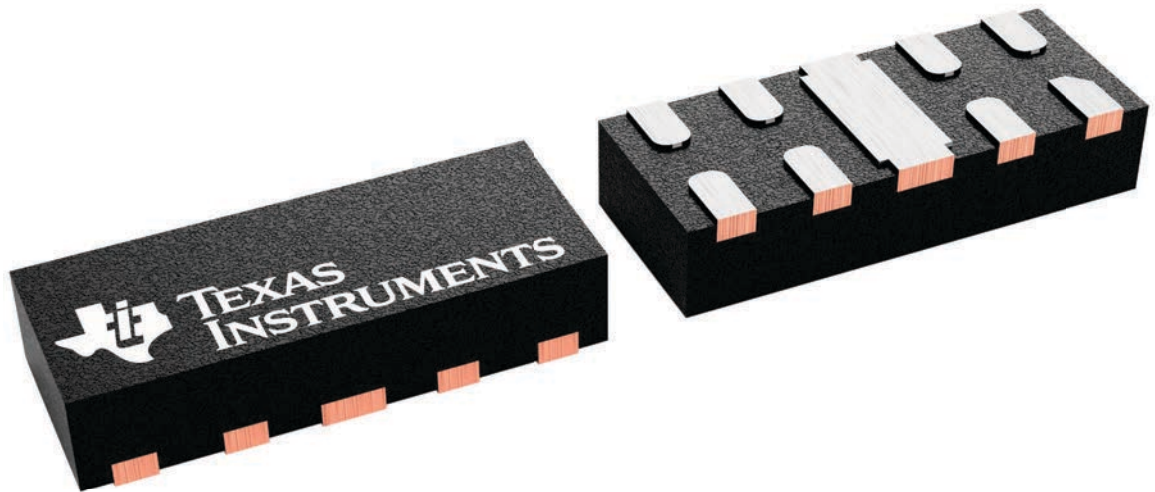

4230320/A

# DQA0010A

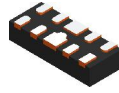

# PACKAGE OUTLINE

USON - 0.55 mm max height

PLASTIC SMALL OUTLINE - NO LEAD

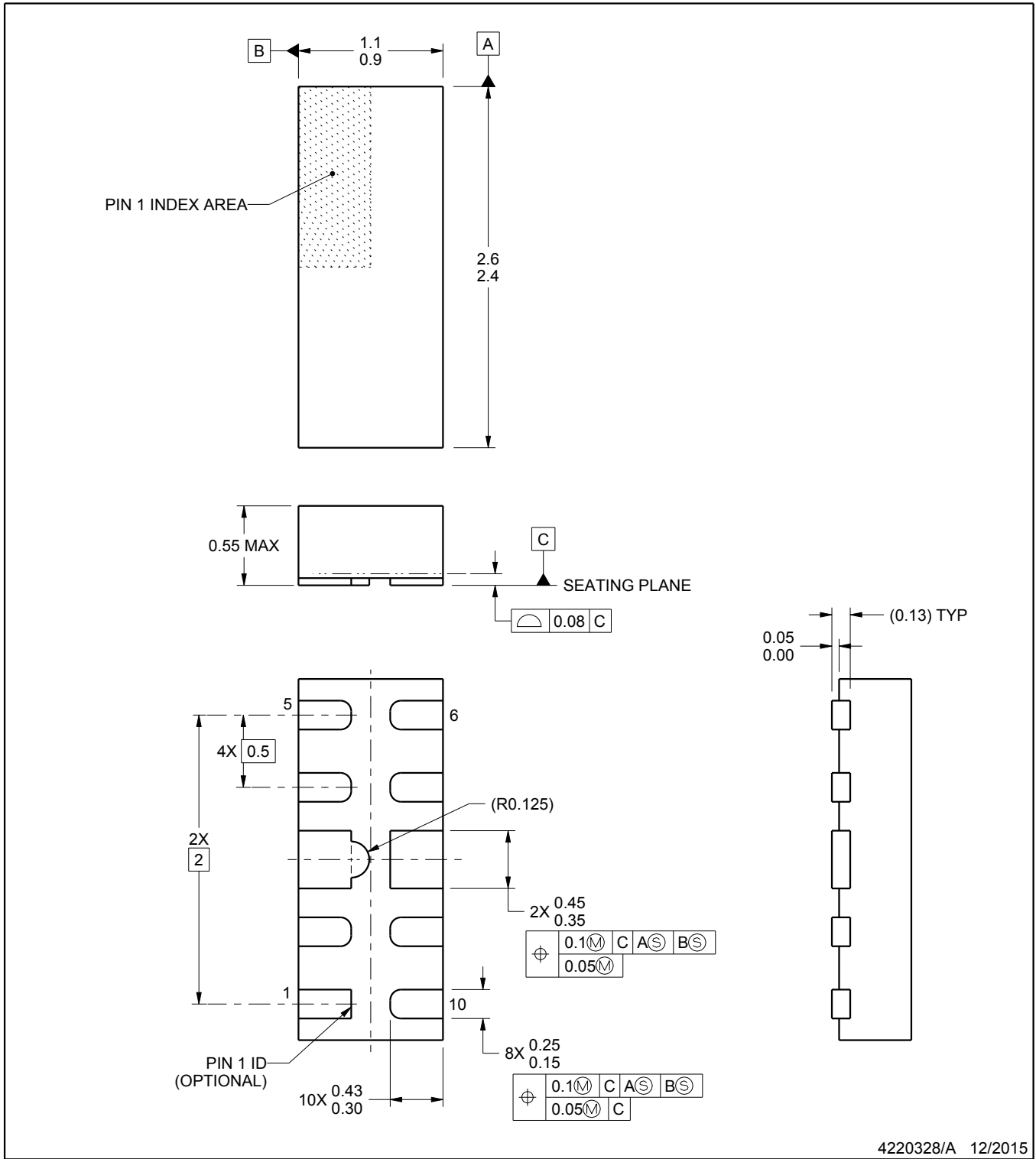

4220328/A 12/2015

NOTES:

1. All linear dimensions are in millimeters. Any dimensions in parenthesis are for reference only. Dimensioning and tolerancing per ASME Y14.5M.
2. This drawing is subject to change without notice.

# EXAMPLE BOARD LAYOUT

DQA0010A

USON - 0.55 mm max height

PLASTIC SMALL OUTLINE - NO LEAD

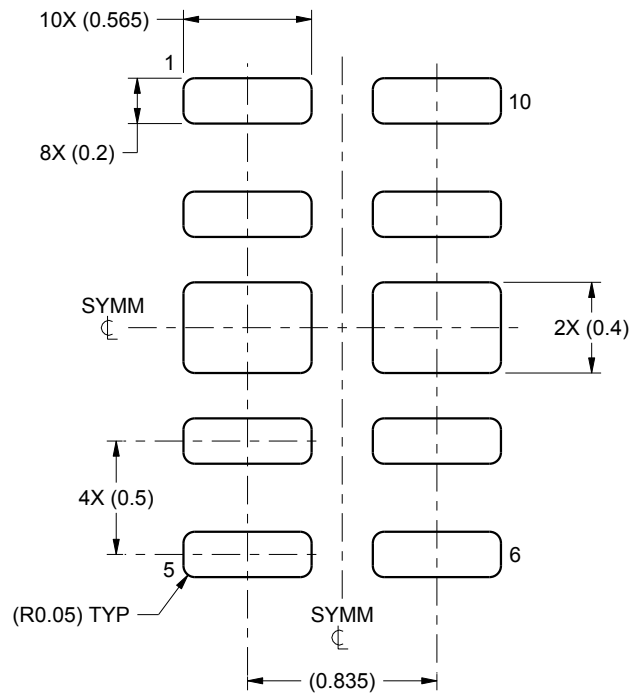

LAND PATTERN EXAMPLE  
SCALE:30X

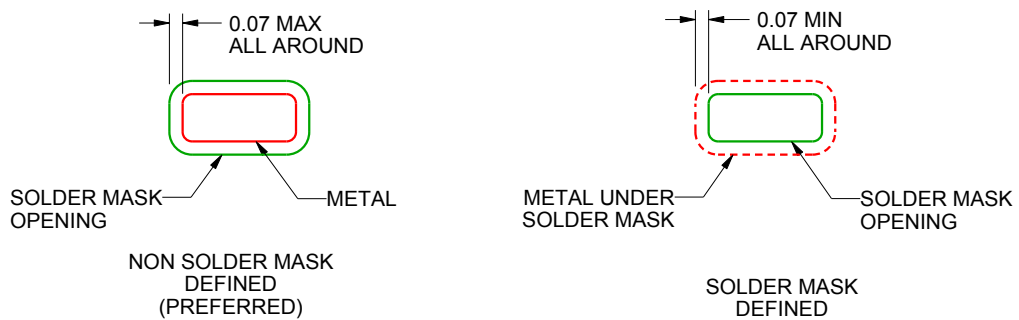

SOLDER MASK DETAILS

4220328/A 12/2015

NOTES: (continued)

3. For more information, see Texas Instruments literature number SLUA271 ([www.ti.com/lit/slua271](http://www.ti.com/lit/slua271)).

# EXAMPLE STENCIL DESIGN

DQA0010A

USON - 0.55 mm max height

PLASTIC SMALL OUTLINE - NO LEAD

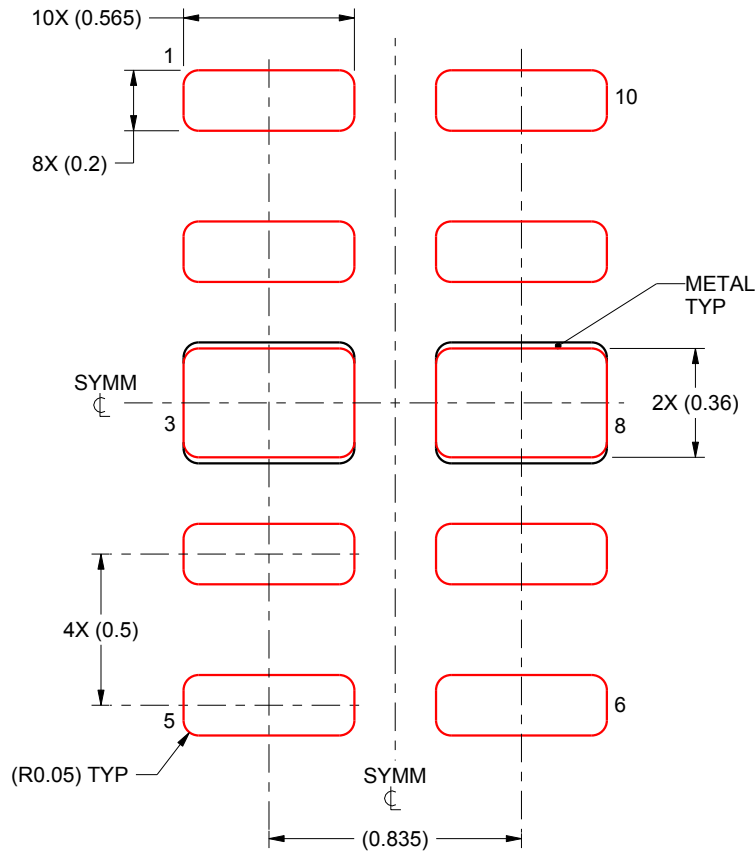

SOLDER PASTE EXAMPLE  
BASED ON 0.1 mm THICK STENCIL

EXPOSED PADS 3 & 8:  
90% PRINTED SOLDER COVERAGE BY AREA UNDER PACKAGE  
SCALE:40X

4220328/A 12/2015

NOTES: (continued)

4. Laser cutting apertures with trapezoidal walls and rounded corners may offer better paste release. IPC-7525 may have alternate design recommendations.

# DQA0010B



# PACKAGE OUTLINE

USON - 0.55 mm max height

PLASTIC SMALL OUTLINE - NO LEAD

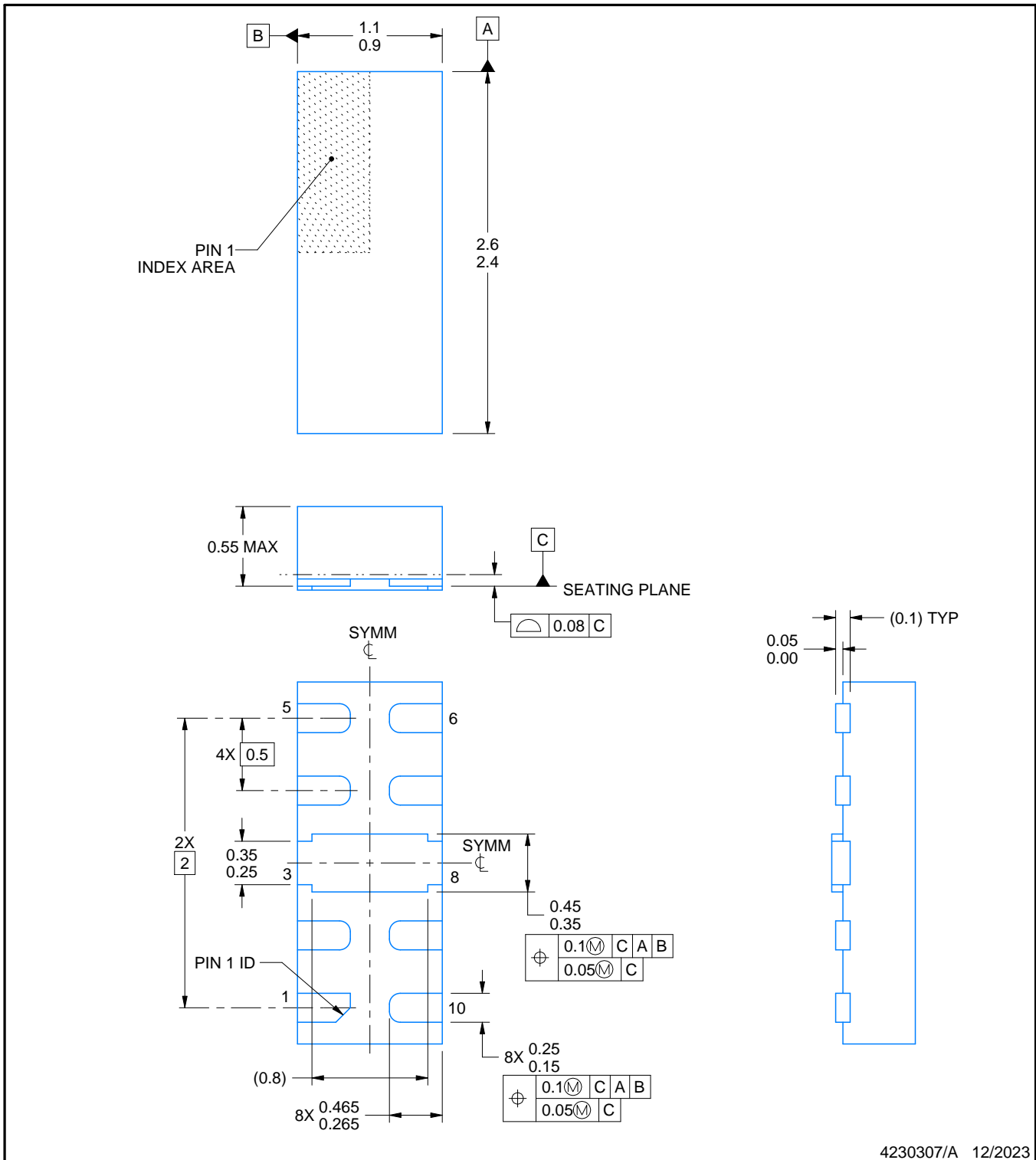

4230307/A 12/2023

**NOTES:**

1. All linear dimensions are in millimeters. Any dimensions in parenthesis are for reference only. Dimensioning and tolerancing per ASME Y14.5M.
2. This drawing is subject to change without notice.

# EXAMPLE BOARD LAYOUT

DQA0010B

USON - 0.55 mm max height

PLASTIC SMALL OUTLINE - NO LEAD

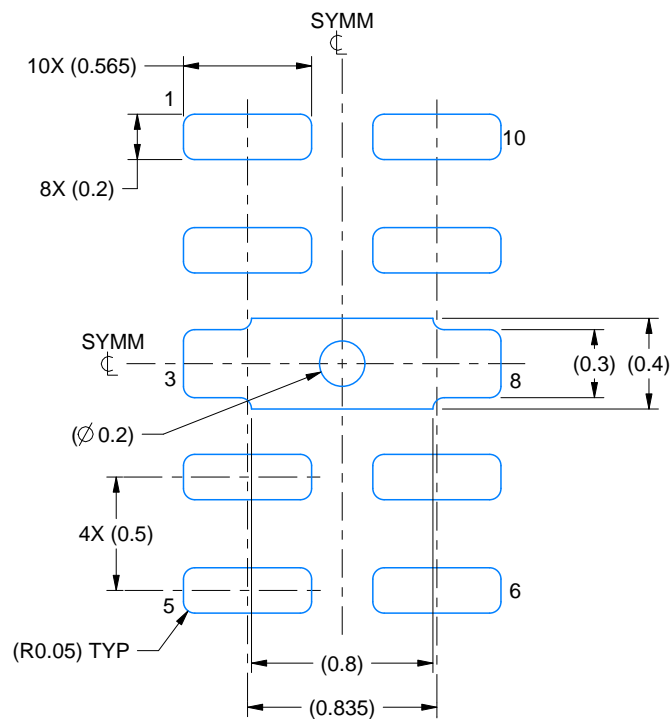

LAND PATTERN EXAMPLE  
EXPOSED METAL SHOWN  
SCALE:30X

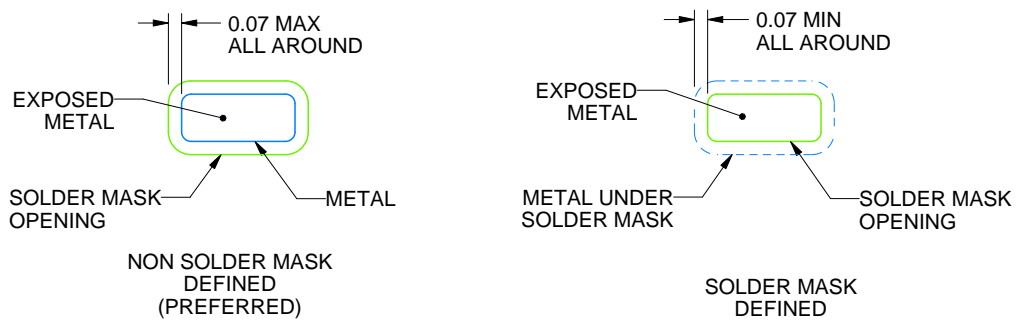

SOLDER MASK DETAILS

4230307/A 12/2023

NOTES: (continued)

3. For more information, see Texas Instruments literature number SLUA271 ([www.ti.com/lit/slua271](http://www.ti.com/lit/slua271)).

# EXAMPLE STENCIL DESIGN

DQA0010B

USON - 0.55 mm max height

PLASTIC SMALL OUTLINE - NO LEAD

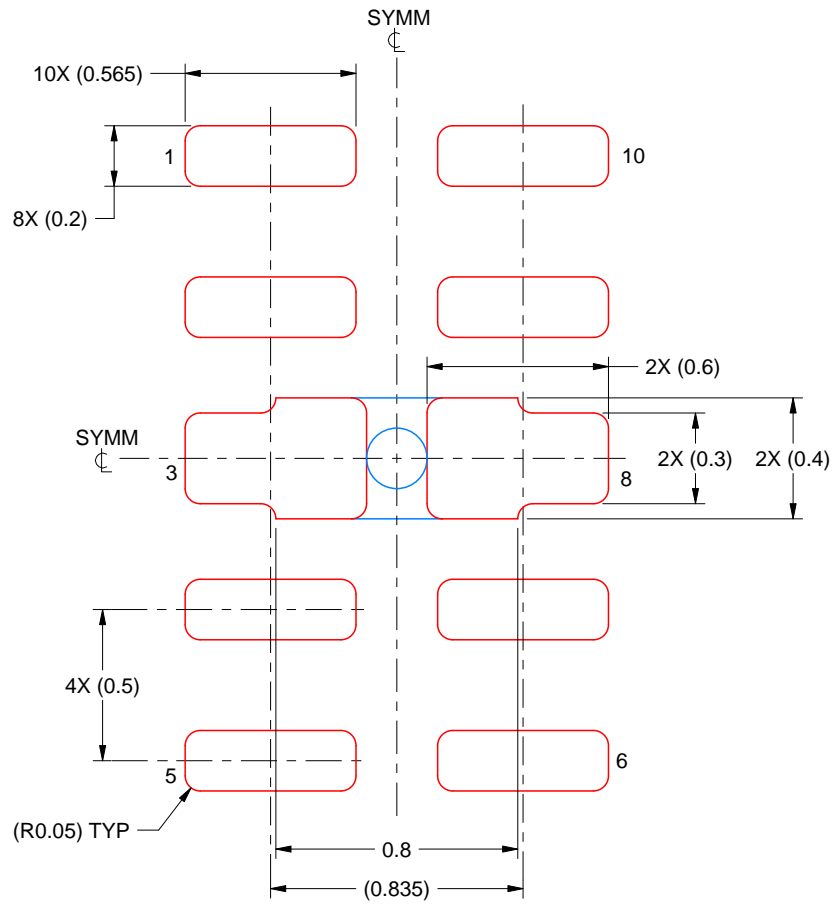

SOLDER PASTE EXAMPLE  
BASED ON 0.1 mm THICK STENCIL  
SCALE:40X

4230307/A 12/2023

NOTES: (continued)

4. Laser cutting apertures with trapezoidal walls and rounded corners may offer better paste release. IPC-7525 may have alternate design recommendations.

## 重要なお知らせと免責事項

TI は、技術データと信頼性データ (データシートを含みます)、設計リソース (リファレンス・デザインを含みます)、アプリケーションや設計に関する各種アドバイス、Web ツール、安全性情報、その他のリソースを、欠陥が存在する可能性のある「現状のまま」提供しており、商品性および特定目的に対する適合性の黙示保証、第三者の知的財産権の非侵害保証を含むいかなる保証も、明示的または黙示的にかかわらず拒否します。

これらのリソースは、TI 製品を使用する設計の経験を積んだ開発者への提供を意図したものです。(1) お客様のアプリケーションに適した TI 製品の選定、(2) お客様のアプリケーションの設計、検証、試験、(3) お客様のアプリケーションに該当する各種規格や、その他のあらゆる安全性、セキュリティ、規制、または他の要件への確実な適合に関する責任を、お客様のみが単独で負うものとし、

上記の各種リソースは、予告なく変更される可能性があります。これらのリソースは、リソースで説明されている TI 製品を使用するアプリケーションの開発の目的でのみ、TI はその使用をお客様に許諾します。これらのリソースに関して、他の目的で複製することや掲載することは禁止されています。TI や第三者の知的財産権のライセンスが付与されている訳ではありません。お客様は、これらのリソースを自身で使用した結果発生するあらゆる申し立て、損害、費用、損失、責任について、TI およびその代理人を完全に補償するものとし、TI は一切の責任を拒否します。

TI の製品は、[TI の販売条件](#)、または [ti.com](#) やかかる TI 製品の関連資料などのいずれかを通じて提供する適用可能な条項の下で提供されています。TI がこれらのリソースを提供することは、適用される TI の保証または他の保証の放棄の拡大や変更を意味するものではありません。

お客様がいかなる追加条項または代替条項を提案した場合でも、TI はそれらに異議を唱え、拒否します。

郵送先住所 : Texas Instruments, Post Office Box 655303, Dallas, Texas 75265  
Copyright © 2024, Texas Instruments Incorporated