

TPS1200-Q1 短絡保護および診断機能搭載、45V、車載用、低 IQ、スマート ハイサイドドライバ

1 特長

- 車載アプリケーション向けに AEC-Q100 認定済み
 - デバイス温度グレード 1: 動作時周囲温度範囲: $-40^{\circ}\text{C} \sim +125^{\circ}\text{C}$
- 機能安全対応
 - 機能安全システムの設計に役立つ資料を利用可能
- 3.5V~40V の入力範囲 (絶対最大定格 45V)
- 最低 -40V までの逆入力保護
- 内蔵 11V チャージポンプ
- 低い静止電流: 43 μA (動作時)
- 低シャットダウン電流 (EN/UVLO = Low): 1.5 μA
- 強力なゲートドライバ (2A のソースとシンク)
- 外付けの R_{sense} または可変遅延 (TMR) 付き MOSFET VDS センシングを使用した可変短絡保護 (ISCP)
- ハイサイドまたはローサイドの電流検出構成 (CS_SEL)
- 短絡故障時のフォルト表示 ($\overline{\text{FLT}}$)、入力低電圧および短絡コンパレータ診断 (SCP_TEST)
- ゲート駆動 UVLO のフォルト表示 (FLT_GD)
- 可変低電圧誤動作防止 (UVLO) および過電圧保護 (OV)

2 アプリケーション

- 車載用 12V BMS
- DC/DC コンバータ
- 電動工具

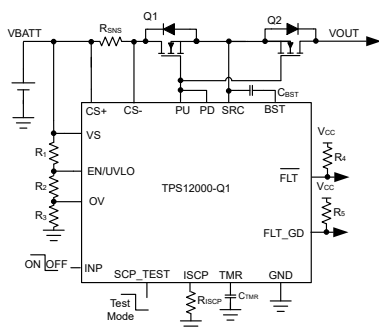

DC-DC 用スマート ハイサイド ドライバ

3 概要

TPS1200-Q1 は、保護および診断機能を備えた、45V、低 IQ、スマート ハイサイドドライバです。本デバイスは、動作電圧範囲が 3.5V~40V と広いため、12V のシステム設計に適しています。このデバイスは、最低 -40V の負の電源電圧に耐えられ、負荷を保護できます。

大電流システム設計において並列 MOSFET を使用して電力スイッチングを可能にする強力な (2A) ゲートドライバを備えています。

このデバイスは、可変短絡保護機能を備えています。自動リトライおよびラッチオフ フォルト動作は設定可能です。電流検出は、CS+ および CS- ピンを使用して、外付けの検出抵抗、または MOSFET VDS センシングのいずれかを使用して実行できます。CS_SEL ピン入力を使用して、ハイサイドまたはローサイドの電流検出抵抗構成が可能です。このデバイスは、SCP_TEST 入力の外部制御を使用した、内蔵の短絡コンパレータを診断する機能も備えています。

動作時の静止電流が 43 μA (代表値) と低いため、常時オンのシステム設計が可能です。EN/UVLO が Low で、静止電流が 1.5 μA (代表値) まで低減します。

TPS1200-Q1 は、19 ピンの VSSOP パッケージで供給されます。

パッケージ情報

| 部品番号 | パッケージ (1) | パッケージ サイズ (2) |
|------------|-----------------|---------------|
| TPS1200-Q1 | DGX (VSSOP, 19) | 5.1mm × 3.0mm |

- 利用可能なすべてのパッケージについては、データシートの末尾にある注文情報を参照してください。
- パッケージ サイズ (長さ × 幅) は公称値であり、該当する場合はピンも含まれます。

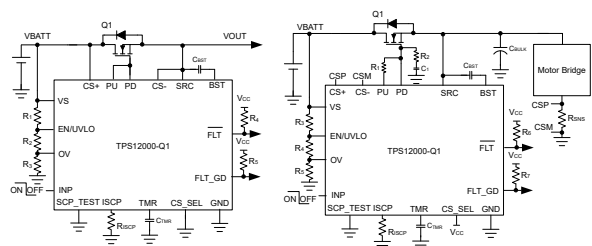

ハイサイド MOSFET VDS センシングとローサイド電流センシングを使用した回路



Table of Contents

| | | | |
|--|----------|--|-----------|
| 1 特長 | 1 | 8 Application and Implementation | 18 |
| 2 アプリケーション | 1 | 8.1 Application Information..... | 18 |
| 3 概要 | 1 | 8.2 Typical Application: Driving Power at all Times (PAAT) Loads..... | 19 |
| 4 Pin Configuration and Functions | 3 | 8.3 Power Supply Recommendations..... | 23 |
| 5 Specifications | 5 | 8.4 Layout..... | 24 |
| 5.1 Absolute Maximum Ratings..... | 5 | 9 Device and Documentation Support | 26 |
| 5.2 ESD Ratings..... | 5 | 9.1 ドキュメントの更新通知を受け取る方法..... | 26 |
| 5.3 Recommended Operating Conditions..... | 5 | 9.2 サポート・リソース..... | 26 |
| 5.4 Thermal Information..... | 6 | 9.3 Trademarks..... | 26 |
| 5.5 Electrical Characteristics..... | 6 | 9.4 静電気放電に関する注意事項..... | 26 |
| 5.6 Switching Characteristics..... | 7 | 9.5 用語集..... | 26 |
| 6 Parameter Measurement Information | 8 | 10 Revision History | 26 |
| 7 Detailed Description | 9 | 11 Mechanical, Packaging, and Orderable Information | 26 |
| 7.1 Overview..... | 9 | 11.1 Tape and Reel Information..... | 27 |
| 7.2 Functional Block Diagram..... | 9 | | |
| 7.3 Feature Description..... | 10 | | |
| 7.4 Device Functional Modes..... | 17 | | |

4 Pin Configuration and Functions



図 4-1. DGX Package, 19-Pin VSSOP (Top View)

表 4-1. Pin Functions

| PIN | | TYPE ⁽¹⁾ | DESCRIPTION |
|---------|-----|---------------------|--|
| NAME | NO. | | |
| EN/UVLO | 1 | I | EN/UVLO input. A voltage on this pin above 1.24V enables normal operation. Forcing this pin below 0.3V shuts down the device reducing quiescent current to approximately 1.5µA (typical). Optionally connect to the input supply through a resistive divider to set the undervoltage lockout. When EN/UVLO is left floating an internal pull down of 100nA pulls EN/UVLO low and keeps the device in shutdown state. |
| OV | 2 | I | Adjustable overvoltage threshold input. Connect a resistor ladder from input supply, OV to GND. When the voltage at OVP exceeds the overvoltage cut-off threshold then the PD is pulled down to SRC turning OFF the external FET. When the voltage at OV goes below OV falling threshold then PU gets pulled up to BST, turning ON the external FET. OV must be connected to GND when not used. When OV is left floating an internal pull down of 100nA pulls OV low and keeps PU pulled up to BST. |
| INP | 3 | I | Input signal for external discharge FET control. CMOS compatible input reference to GND that sets the state of PD and PU pins. INP has an internal weak pull down of 100nA to GND to keep PD pulled to SRC when INP is left floating. |
| FLT_GD | 4 | O | Open drain fault output for gate drive UVLO. This pin asserts low when gate drive across PU to SRC is above 7.5V. |
| FLT | 5 | O | Open drain fault output. This pin asserts low during short circuit fault, input UVLO and during SCP comparator diagnosis. If FLT feature is not desired then connect it to GND. |
| GND | 6 | G | Connect GND to system ground. |

表 4-1. Pin Functions (続き)

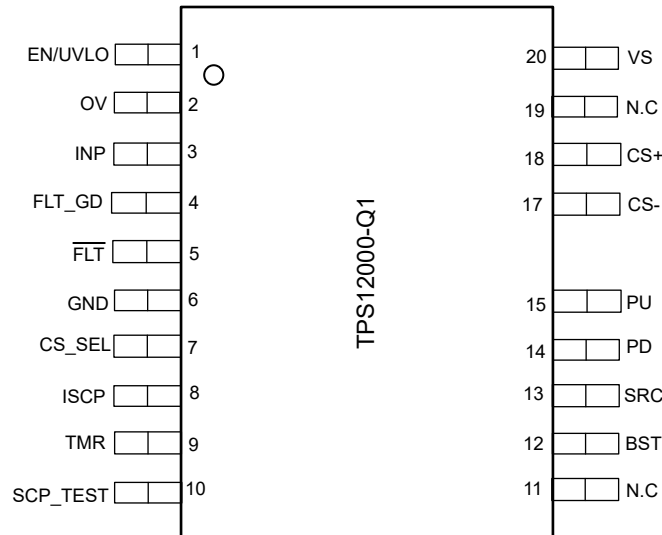
| PIN | | TYPE ⁽¹⁾ | DESCRIPTION |
|----------|-----|---------------------|---|
| NAME | NO. | | |
| CS_SEL | 7 | I | Current sense select input. Connect this pin to ground to activate high side current sense. Drive this pin to > 2V to activate low side current sensing. CS_SEL has an internal weak pull down of 100nA to GND. |
| ISCP | 8 | I | Short-circuit detection setting. A resistor across ISCP to GND sets the short circuit current comparator threshold. If short-circuit protection feature is not desired then connect CS+, CS-, and VS pins together and connect ISCP and TMR pins to GND. |
| TMR | 9 | I | Fault timer input. A capacitor across TMR pin to GND sets the delay time for short-circuit fault turn-off. Leave it open for fastest setting. If short-circuit protection feature is not desired then connect CS+, CS-, and VS pins together and connect ISCP and TMR pins to GND. |
| SCP_TEST | 10 | I | Internal short circuit comparator (SCP) diagnosis input. When SCP_TEST is driven low to high with INP pulled high, the internal SCP comparator operation is checked. FLT goes low and PD gets pulled to SRC if SCP comparator is functional. Connect SCP_TEST pin to GND if this feature is not desired. SCP_TEST has an internal weak pull down of 100nA to GND. |
| NC | 11 | — | No connect. |
| BST | 12 | O | High side bootstrapped supply. An external capacitor with a minimum value of > Q _{g(tot)} of the external FET must be connected between this pin and SRC. |
| SRC | 13 | O | Source connection of the external FET |
| PD | 14 | O | High current gate driver pull-down. This pin pulls down to SRC. For the fastest turn-off, tie this pin directly to the gate of the external high side MOSFET. |
| PU | 15 | O | High current gate driver pull-up. This pin pulls up to BST. Connect this pin to PD for maximum gate drive transition speed. A resistor can be connected between this pin and the gate of the external MOSFET to control the in-rush current during turn-on. |
| CS- | 17 | I | Current sense negative input. |
| CS+ | 18 | I | Current sense positive input. |
| NC | 19 | — | No connect. |
| VS | 20 | Power | Supply pin of the controller. |

(1) I = input, O = output, I/O = input and output, P = power, G = ground

5 Specifications

5.1 Absolute Maximum Ratings

over operating free-air temperature range (unless otherwise noted)⁽¹⁾

| | | MIN | MAX | UNIT |
|--|--|------------|-------------------|------|
| Input pins | VS, CS+, CS– to GND | –40 | 45 | V |
| | SRC to GND | –40 | 45 | |
| | PU, PD, BST to SRC | –0.3 | 19 | |
| | ISCP, TMR, SCP_TEST to GND | –0.3 | 5.5 | |
| | EN/UVLO, OV, INP, CS_SEL to GND, $V_{(VS)} > 0$ V | –1 | 45 | |
| | EN/UVLO, OV, INP, CS_SEL to GND, $V_{(VS)} \leq 0$ V | $V_{(VS)}$ | $(45 + V_{(VS)})$ | |
| | CS+ to CS– | –1 | 45 | |
| | FLT, FLT_GD to GND | –1 | 20 | |
| Sink current | $I_{(FLT)}$, $I_{(FLT_GD)}$ | | 10 | mA |
| | $I_{(CS+)}$ to $I_{(CS-)}$, 1 msec | –100 | 100 | mA |
| Output pins | PU, PD, BST to GND | –40 | 60 | V |
| Operating junction temperature, T_j ⁽²⁾ | | –40 | 150 | °C |
| Storage temperature, T_{stg} | | –40 | 150 | |

- Operation outside the Absolute Maximum Ratings may cause permanent device damage. Absolute Maximum Ratings do not imply functional operation of the device at these or any other conditions beyond those listed under Recommended Operating Conditions. If used outside the Recommended Operating Conditions but within the Absolute Maximum Ratings, the device may not be fully functional, and this may affect device reliability, functionality, performance, and shorten the device lifetime.
- High junction temperatures degrade operating lifetimes. Operating lifetime is de-rated for junction temperatures greater than 125°C.

5.2 ESD Ratings

| | | | VALUE | UNIT | |
|-------------|-------------------------|---|-------------------------------------|------|------|
| $V_{(ESD)}$ | Electrostatic discharge | Human body model (HBM), per AEC Q100-002 ⁽¹⁾ | ±2000 | V | |
| | | Charged device model (CDM), per AEC Q100-011 | Corner pins (EN/UVLO, VS, SCP_TEST) | | ±750 |
| | | | Other pins | | ±500 |

- AEC Q100-002 indicates that HBM stressing shall be in accordance with the ANSI/ESDA/JEDEC JS-001 specification.

5.3 Recommended Operating Conditions

over operating free-air temperature range (unless otherwise noted)⁽¹⁾

| | | MIN | NOM | MAX | UNIT |
|--------------------|---|-----|-----|-----|------|
| Input pins | VS to GND | 3.5 | | 40 | V |
| | EN/UVLO, INP, CS_SEL to GND | 0 | | 40 | |
| Output pins | FLT, FLT_GD to GND | 0 | | 15 | |
| External capacitor | VS, SRC to GND | 22 | | | nF |
| | BST to SRC | 0.1 | | | μF |
| T_j | Operating Junction temperature ⁽²⁾ | –40 | | 150 | °C |

- Recommended Operating Conditions are conditions under which the device is intended to be functional. For specifications and test conditions, see Electrical Characteristics.
- High junction temperatures degrade operating lifetimes. Operating lifetime is de-rated for junction temperatures greater than 125°C.

5.4 Thermal Information

| THERMAL METRIC ⁽¹⁾ | | TPS1200-Q1 | | UNIT |
|-------------------------------|--|------------|--|------|
| | | DGX | | |
| | | 19 PINS | | |
| R _{θJA} | Junction-to-ambient thermal resistance | 92.3 | | °C/W |
| R _{θJC(top)} | Junction-to-case (top) thermal resistance | 28.6 | | °C/W |
| R _{θJB} | Junction-to-board thermal resistance | 47.5 | | °C/W |
| Ψ _{JT} | Junction-to-top characterization parameter | 0.6 | | °C/W |
| Ψ _{JB} | Junction-to-board characterization parameter | 47.2 | | °C/W |

(1) For more information about traditional and new thermal metrics, see the [Semiconductor and IC Package Thermal Metrics](#) application report.

5.5 Electrical Characteristics

T_J = -40 °C to +125°C. V_(VS) = 12 V, V_(BST - SRC) = 11 V, V_(SRC) = 0 V

| PARAMETER | | TEST CONDITIONS | MIN | TYP | MAX | UNIT |
|---|---|--|-----|------|------|------|
| SUPPLY VOLTAGE | | | | | | |
| V _(VS) | Operating input voltage | | 3.5 | | 40 | V |
| | Total System Quiescent current, I _(GND) | V _(EN/UVLO) = 2 V | | 43 | | μA |
| I _(SHDN) | SHDN current, I _(GND) | V _(EN/UVLO) = 0 V, V _(SRC) = 0 V | | 1.5 | | μA |
| ENABLE, UNDERVOLTAGE LOCKOUT (EN/UVLO), SHORT CIRCUIT COMPARATOR TEST (SCP_TEST) INPUT | | | | | | |
| V _(UVLOR) | UVLO threshold voltage, rising | | | 1.24 | | V |
| V _(UVLOF) | UVLO threshold voltage, falling | | | 1.14 | | V |
| V _(ENR) | Enable threshold voltage for low I _q shutdown, rising | | | | 1.02 | V |
| V _(ENF) | Enable threshold voltage for low I _q shutdown, falling | | 0.3 | | | V |
| V _(SCP_TESTR) | SCP test mode rising threshold | | | | 1.02 | V |
| V _(SCP_TESTF) | SCP test mode falling threshold | | 0.3 | | | V |
| I _(EN/UVLO) | Enable input leakage current | V _(EN/UVLO) = 12 V | | 180 | | nA |
| OVER VOLTAGE PROTECTION (OV) INPUT | | | | | | |
| V _(OVR) | Overvoltage threshold input, rising | | | 1.24 | | V |
| V _(OVF) | Overvoltage threshold input, falling | | | 1.14 | | V |
| CHARGE PUMP (BST-SRC) | | | | | | |
| V _(BST - SRC_ON) | Charge Pump turn on voltage | V _(EN/UVLO) = 2 V | 10 | | | V |
| V _(BST - SRC_OFF) | Charge Pump turn off voltage | V _(EN/UVLO) = 2 V | | | 11.8 | V |
| V _(BST_UVLOR) | V _(BST - SRC) UVLO voltage threshold, rising | V _(EN/UVLO) = 2 V | | | 9.5 | V |
| V _(BST_UVLOF) | V _(BST - SRC) UVLO voltage threshold, falling | V _(EN/UVLO) = 2 V | 7.2 | | | V |
| I _(SRC) | SRC pin leakage current | V _(EN/UVLO) = 2 V, V _(INP) = 0 V | | 1 | | μA |
| GATE DRIVER OUTPUTS (PU, PD) | | | | | | |
| I _(PU) | Peak source current | | | 1.69 | | A |
| I _(PD) | Peak sink current | | | 2 | | A |
| V _(G_GOOD) | VGS good threshold | | | 7.5 | | V |
| SHORT CIRCUIT PROTECTION (ISCP) | | | | | | |
| V _(SCP) | SCP threshold | R _{ISCP} = 32.5 kΩ | 60 | 75 | 90 | mV |
| V _(SCP) | SCP threshold | R _{ISCP} = 15 kΩ | | 40 | | mV |

5.5 Electrical Characteristics (続き)

$T_J = -40\text{ }^\circ\text{C}$ to $+125\text{ }^\circ\text{C}$. $V_{(VS)} = 12\text{ V}$, $V_{(BST-SRC)} = 11\text{ V}$, $V_{(SRC)} = 0\text{ V}$

| PARAMETER | | TEST CONDITIONS | MIN | TYP | MAX | UNIT |
|---|--|-----------------|-----|-----|-----|---------------|
| DELAY TIMER (TMR) | | | | | | |
| $I_{(TMR_SRC_CB)}$ | TMR source current | | | 80 | | μA |
| $I_{(TMR_SRC_FLT)}$ | TMR source current | | | 2.2 | | μA |
| $I_{(TMR_SNK)}$ | TMR sink current | | | 2.5 | | μA |
| $V_{(TMR_SC)}$ | | | | 1.1 | | V |
| $V_{(TMR_LOW)}$ | | | | 0.2 | | V |
| $N_{(A-R\text{ Count})}$ | | | | 32 | | |
| INPUT CONTROLS (INP), CURRENT SENSE SELECT (CS_SEL), FAULT FLAGS (FLT, FLT_GD) | | | | | | |
| $R_{(FLT)}, R_{(FLT_GD)}$ | Pull-down resistance | | | 70 | | Ω |
| $V_{(INP_H)}$ | | | | | 2 | V |
| $V_{(INP_L)}$ | | | 0.8 | | | V |
| $V_{(CS_SEL_H)}$ | CS_SEL threshold for low side sensing | | | | 2 | V |
| $V_{(CS_SEL_L)}$ | CS_SEL threshold for high side sensing | | 0.8 | | | V |

5.6 Switching Characteristics

$T_J = -40\text{ }^\circ\text{C}$ to $+125\text{ }^\circ\text{C}$. $V_{(VS)} = 12\text{ V}$, $V_{(BST-SRC)} = 11\text{ V}$, $V_{(SRC)} = 0\text{ V}$

| PARAMETER | | TEST CONDITIONS | MIN | TYP | MAX | UNIT |
|---------------------|--|--|-----|-----|-----|---------------|
| $t_{PU(INP_H)}$ | INP turn on propagation delay | INP \uparrow to PU \uparrow , $C_L = 47\text{ nF}$ | | 1 | | μs |
| $t_{PD(INP_L)}$ | INP turn off propagation delay | INP \downarrow to PD \downarrow , $C_L = 47\text{ nF}$ | | 5 | | μs |
| $t_{PD(UVLO_OFF)}$ | UVLO turn off propagation delay | UVLO \downarrow to PD \downarrow , $C_L = 47\text{ nF}$ | | 7.5 | | μs |
| $t_{PD(OV_OFF)}$ | OV turn off propagation delay | OV \uparrow to PD \downarrow , $C_L = 47\text{ nF}$ | | 7.5 | | μs |
| t_{SC} | Hard short-circuit protection propagation delay | $V_{(CS+-CS-)} \uparrow V_{(SCP)}$ to PD \downarrow , $C_L = 47\text{ nF}$, $C_{TMR} = \text{Open}$ | | 4 | | μs |
| t_{SC_PUS} | Short-circuit protection propagation delay during power up with output short circuit | $C_{TMR} = \text{Open}$ | | | 10 | μs |

6 Parameter Measurement Information

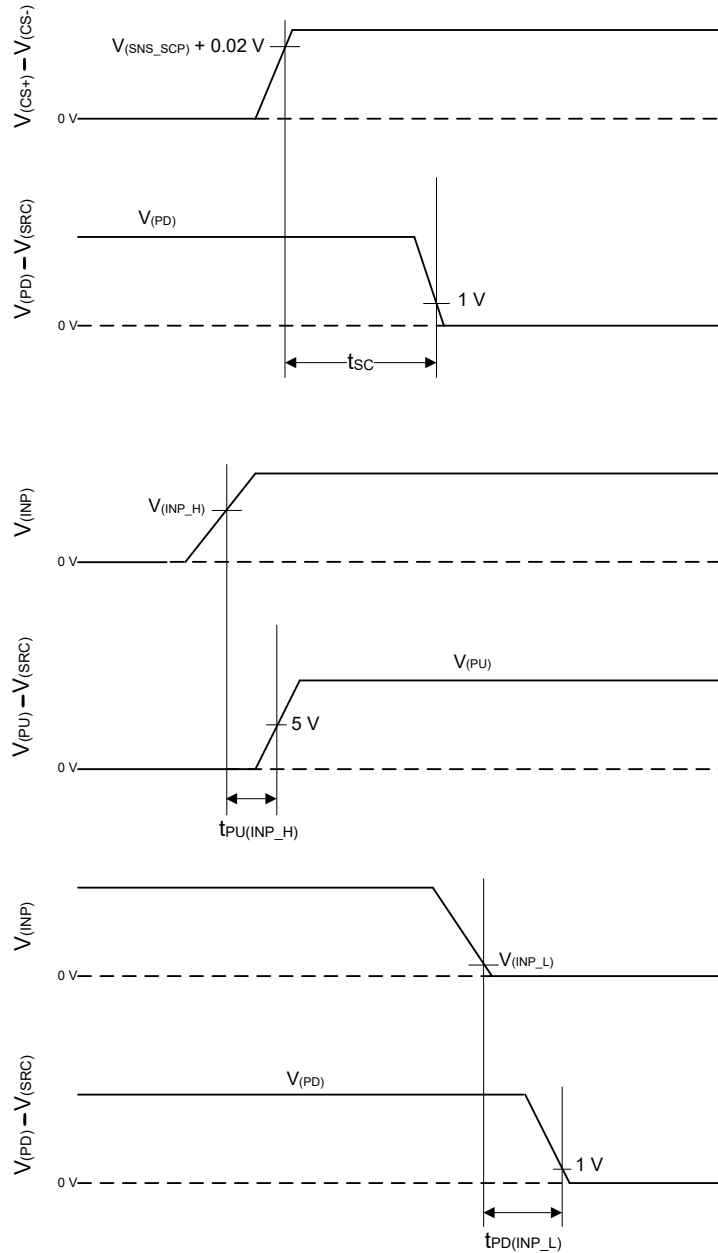

6-1. Timing Waveforms

ADVANCE INFORMATION

7 Detailed Description

7.1 Overview

The TPS12000-Q1 is a 45V low IQ smart high side driver with protection and diagnostics. With wide operating voltage range of 3.5V–40V, the device is suitable for 12V system designs. The device can withstand and protect the loads from negative supply voltages down to –40V.

It has strong 1.69A and 2A peak source and sink gate driver enabling power switching using parallel FETs in high current system designs.

The device provides configurable short circuit protection using ISCP and TMR pins for adjusting the threshold and response time respectively. Auto-retry and latch-off fault behavior can be configured. With TPS12000-Q1, current sensing can be done either by an external sense resistor or by MOSFET VDS sensing. High or low side current sense resistor configuration is possible by using CS_SEL pin input. Diagnosis of the integrated short circuit comparator can be done using external control on SCP_TEST input.

The device has adjustable undervoltage and overvoltage protection.

The device indicates fault ($\overline{\text{FLT}}$) on open drain output during during short circuit and input under voltage conditions. It also have a dedicate fault indication (FLT_GD) to indicate the gate drive UVLO condition.

Low Quiescent Current 43 μA operation enables always ON system designs. Quiescent current reduces to 1.5 μA (typical) with EN/UVLO low.

7.2 Functional Block Diagram

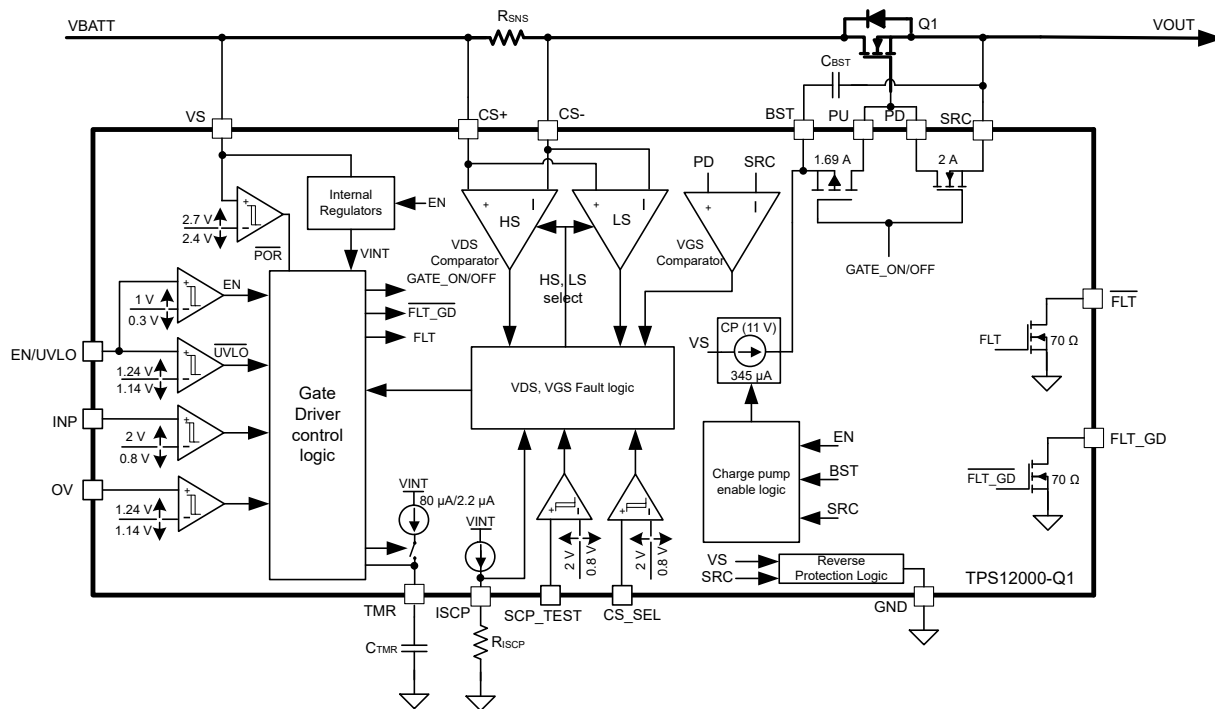

7.3 Feature Description

7.3.1 Charge Pump and Gate Driver Output (VS, PU, PD, BST, SRC)

Figure 7-1 shows a simplified diagram of the charge pump and gate driver circuit implementation. The device houses a strong 1.69-A/2-A peak source/sink gate driver (PU, PD) for driving power FET. The strong gate drivers enable paralleling of FETs in high power system designs ensuring minimum transition time in saturation region. A 11-V, 345- μ A charge pump is derived from VS terminal and charges the external boot-strap capacitor, C_{BST} that is placed across the gate driver (BST and SRC).

VS is the supply pin to the controller. With VS applied and EN/UVLO pulled high, the charge pump turns ON and charges the C_{BST} capacitor. After the voltage across C_{BST} crosses $V_{(BST_UVLOR)}$, the GATE driver section is activated. The device has a 1-V (typical) UVLO hysteresis to ensure chattering less performance during initial GATE turn ON. Choose C_{BST} based on the external FET Q_G and allowed dip during FET turn-ON. The charge pump remains enabled until the BST to SRC voltage reaches 11.8 V, typically, at which point the charge pump is disabled decreasing the current draw on the VS pin. The charge pump remains disabled until the BST to SRC voltage discharges to 10 V typically at which point the charge pump is enabled. The voltage between BST and SRC continue to charge and discharge between 11.8 V and 10 V as shown in the Figure 7-2.

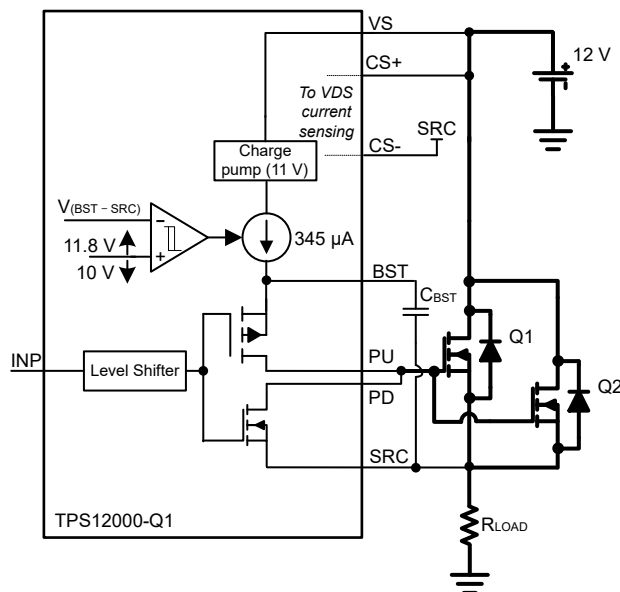

Figure 7-1. Gate Driver



図 7-2. Charge Pump Operation

Use the following equation to calculate the initial gate driver enable delay:

$$T_{\text{DRV_EN}} = \frac{C_{\text{BST}} \times V_{\text{(BST_UVLOR)}}}{345 \mu\text{A}} \quad (1)$$

Where,

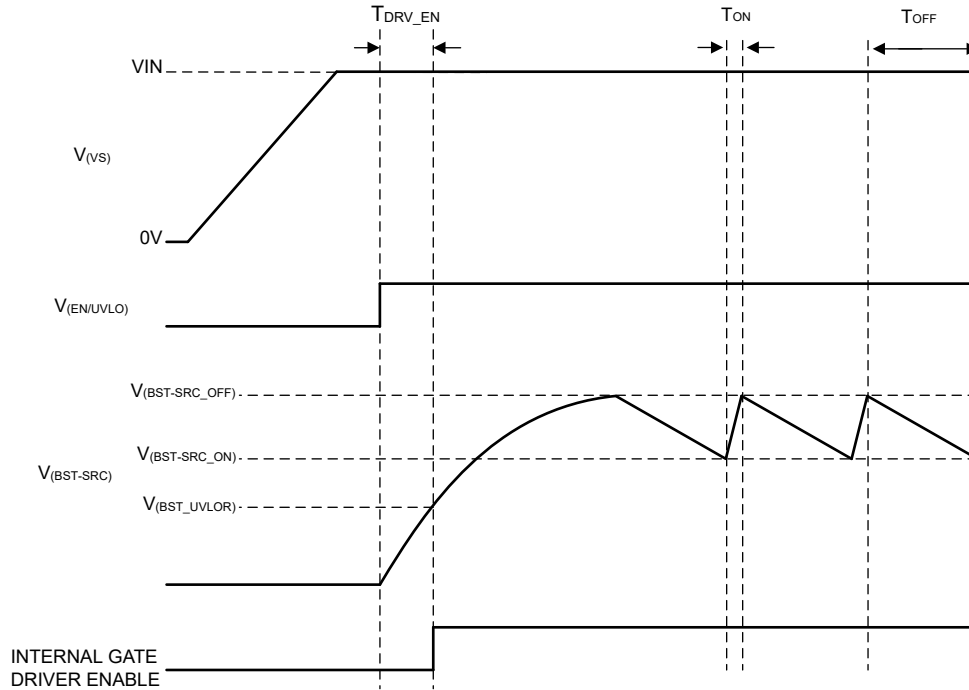
C_{BST} is the charge pump capacitance connected across BST and SRC pins.

$V_{\text{(BST_UVLOR)}} = 9.5 \text{ V (max)}$.

If $T_{\text{DRV_EN}}$ must be reduced then pre-bias BST terminal externally using an external V_{AUX} supply through a low leakage diode D_1 as shown in 図 7-3. With this connection, $T_{\text{DRV_EN}}$ reduces to 400 μs . TPS1200-Q1 application circuit with external supply to BST is shown in 図 7-3.



図 7-3. TPS1200-Q1 Application Circuit With External Supply to BST

注

V_{AUX} can be supplied by external regulated supply ranging between 8 V and 18 V.

7.3.2 Capacitive Load Driving Using FET Gate (PU, PD) Slew Rate Control

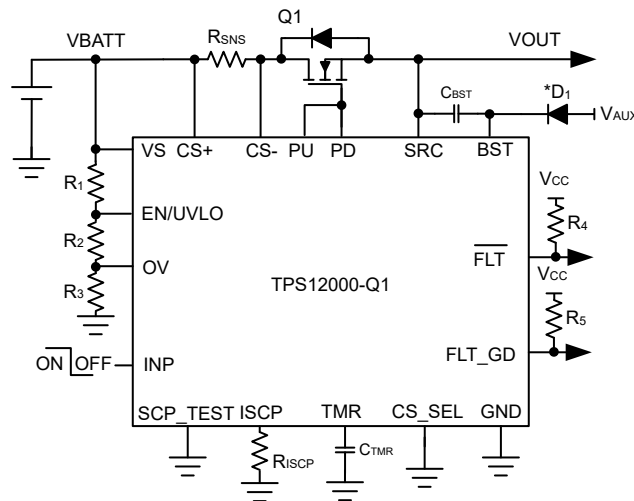
Certain end equipments like automotive power distribution unit power different loads including other ECUs. These ECUs can have large input capacitances. If power to the ECUs is switched on in uncontrolled way, large inrush currents can occur potentially damaging the power FETs. To limit the inrush current during capacitive load switching, the following system design technique can be used with TPS1200-Q1.

For limiting inrush current during turn ON of the FET with capacitive loads, use R_1 , R_2 , C_1 as shown in 図 7-4. The R_1 and C_1 components slow down the voltage ramp rate at the gate of the FET. The FET source follows the gate voltage resulting in a controlled voltage ramp across the output capacitors.



図 7-4. Inrush Current limiting

Use the 式 2 to calculate the inrush current during turn-ON of the FET.

$$I_{INRUSH} = C_{LOAD} \times \frac{V_{BATT}}{T_{charge}} \quad (2)$$

$$C_1 = \frac{0.63 \times V_{(BST - SRC)} \times C_{LOAD}}{R_1 \times I_{INRUSH}} \quad (3)$$

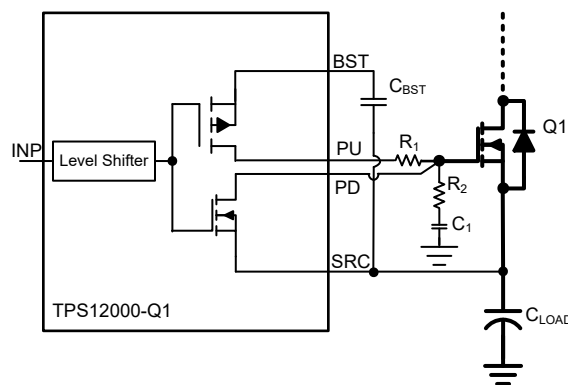
Where,

C_{LOAD} is the load capacitance,

V_{BATT} is the input voltage and T_{charge} is the charge time,

$V_{(BST-SRC)}$ is the charge pump voltage (11 V),

Use a damping resistor R_2 (~ 10 Ω) in series with C_1 . 式 3 can be used to compute required C_1 value for a target inrush current. A 100 k Ω resistor for R_1 can be a good starting point for calculations.

Connecting PD pin of TPS12000-Q1 directly to the gate of the external FET ensures fast turn OFF without any impact of R_1 and C_1 components.

C_1 results in an additional loading on C_{BST} to charge during turn-ON. Use below equation to calculate the required C_{BST} value:

$$C_{BST} = \frac{Q_{g(total)}}{\Delta V_{BST}} + 10 \times C_1 \quad (4)$$

Where,

$Q_{g(total)}$ is the total gate charge of the FET.

ΔV_{BST} (1 V typical) is the ripple voltage across BST to SRC pins.

7.3.3 Short-Circuit Protection

The TPS12000-Q1 feature adjustable short circuit protection. The threshold and response time can be adjusted using R_{ISCP} resistor and C_{TMR} capacitor respectively. The device senses the voltage across $CS+$ and $CS-$ pins.

These pins can be connected across an external high and low side current sense resistor (R_{SNS}) as or across the FET drain and source terminals for FET $R_{DS(ON)}$ sensing shown in 図 7-5, 図 7-6, 図 7-7 and 図 7-8 respectively.

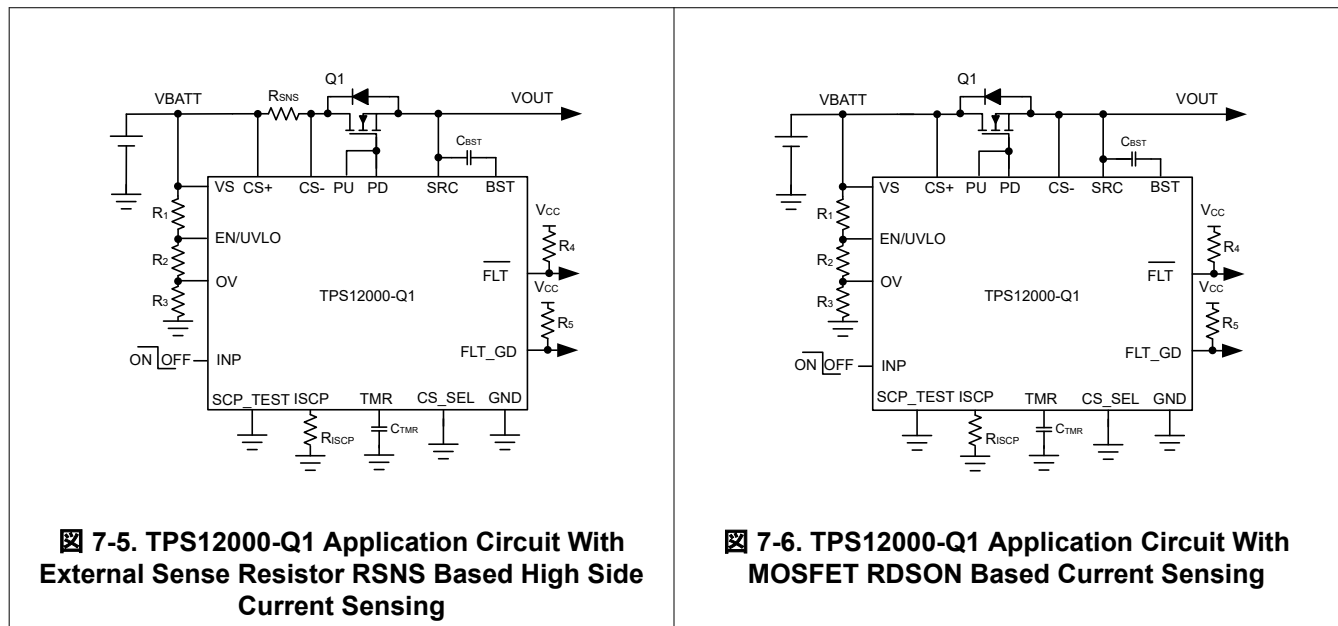



図 7-7. TPS1200-Q1 Application Circuit With External Sense Resistor RSNS Based Low Side Current Sensing on Battery Side



図 7-8. TPS1200-Q1 Application Circuit With External Sense Resistor RSNS on Based Low Side Current Sensing on Load Side

Set the short-circuit detection threshold using an external R_{ISCP} resistor across ISCP and GND pins. Use 式 5 to calculate the required R_{ISCP} value:

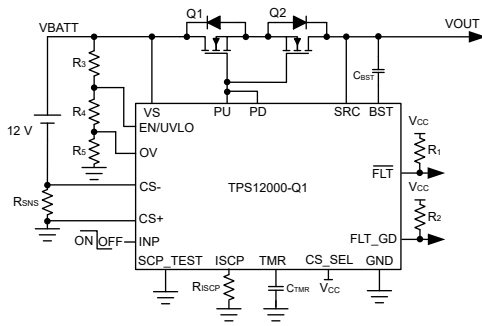
$$R_{ISCP} (\Omega) = \frac{(I_{SC} \times R_{SNS} - 10 \text{ mV})}{2 \mu\text{A}} \quad (5)$$

Refer to 式 9 in セクション 8.1.1 section for update in equation in final revision of IC.

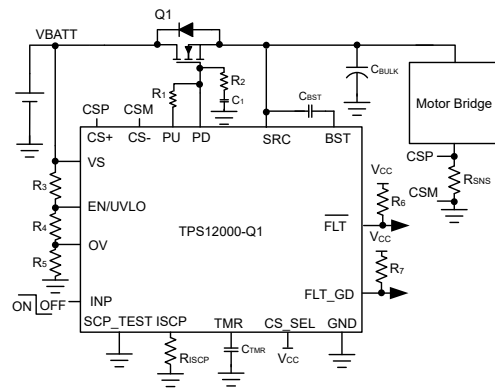
Where,

R_{SNS} is the high or low side current sense resistor value or the FET R_{DSON} value.

I_{SC} is the desired short circuit current level.

The short circuit protection response is fastest with no C_{TMR} cap connected across TMR and GND pins.

With device powered ON and EN/UVLO, INP pulled high, During Q_1 turn ON, first VGS of external FET is sensed by monitoring the voltage across PD to SRC. Once PD to SRC voltage raises above $V_{(G_GOOD)}$ (7.5 V typical) threshold which ensures that the external FET is enhanced, then the SCP comparator output is monitored. If the sensed voltage across CS+ and CS- exceeds the short-circuit set point (V_{SCP}), PD pulls low to SRC and \overline{FLT} asserts low. Subsequent events can be set either to be auto-retry or latch off as described in following sections.

VGS of external FET (Q_1) is only monitored when CS_SEL is pulled low. VGS of external FET (Q_1) is not monitored for low side current sensing as shown 図 7-7 and 図 7-8.

7.3.3.1 Short-Circuit Protection With Auto-Retry

The C_{TMR} programs the short-circuit protection delay (t_{SC}) and auto-retry time (t_{RETRY}). Once the voltage across CS+ and CS- exceeds the set point, the C_{TMR} starts charging with 80- μA pull-up current.

After C_{TMR} charges to $V_{(TMR_SC)}$, PD pulls low to SRC and \overline{FLT} asserts low providing warning on impending FET turn OFF. Post this event, the auto-retry behavior starts. The C_{TMR} capacitor starts discharging with 2.5- μA pulldown current. After the voltage reaches $V_{(TMR_LOW)}$ level, the capacitor starts charging with 2.2- μA pullup. After 32 charging-discharging cycles of C_{TMR} the FET turns ON back and FLT de-asserts.

The device retry time (t_{RETRY}) is based on C_{TMR} for the first time as per 式 7.

Use 式 6 to calculate the C_{TMR} capacitor to be connected across TMR and GND.

$$C_{TMR} = \frac{I_{TMR} \times t_{SC}}{1.1} \quad (6)$$

Where,

I_{TMR} is internal pull-up current of 80- μ A.

t_{SC} is desired short-circuit response time.

Leave TMR floating for fastest short-circuit response time.

$$t_{RETRY} = 22.7 \times 10^6 \times C_{TMR} \quad (7)$$

If the short-circuit pulse duration is below t_{SC} then the FET remains ON and C_{TMR} gets discharged using internal pull down switch.



图 7-9. Short-Circuit Protection With Auto-Retry

7.3.3.2 Short-Circuit Protection With Latch-Off

Connect an approximately 100-k Ω resistor across C_{TMR} as shown in . With this resistor, during the charging cycle, the voltage across C_{TMR} gets clamped to a level below $V_{(TMR_SC)}$ resulting in a latch-off behavior and FLT asserts low at same time.

Use 式 8 to calculate C_{TMR} capacitor to be connected between TMR and GND for $R_{TMR} = 100$ -k Ω .

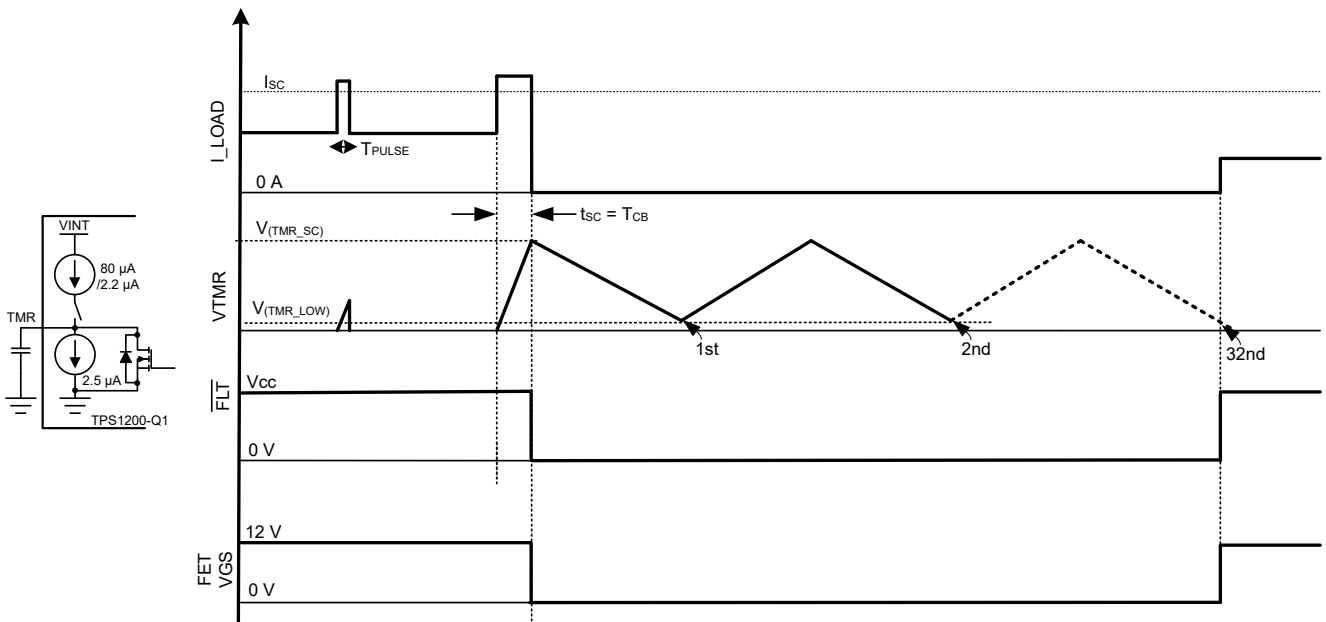
$$C_{TMR} = \frac{t_{SC}}{R_{TMR} \times \ln\left(\frac{1}{1 - \frac{1.1}{R_{TMR} \times 80 \mu A}}\right)} \quad (8)$$

Where,

I_{TMR} is internal pull-up current of 80- μ A.

t_{SC} is desired short-circuit response time.

Toggle INP or EN/UVLO (below $V_{(ENF)}$) or power cycle VS below $V_{(VS_PORF)}$ to reset the latch. At low edge, the timer counter is reset and C_{TMR} is discharged. PU pulls up to BST when INP is pulled high.

ADVANCE INFORMATION

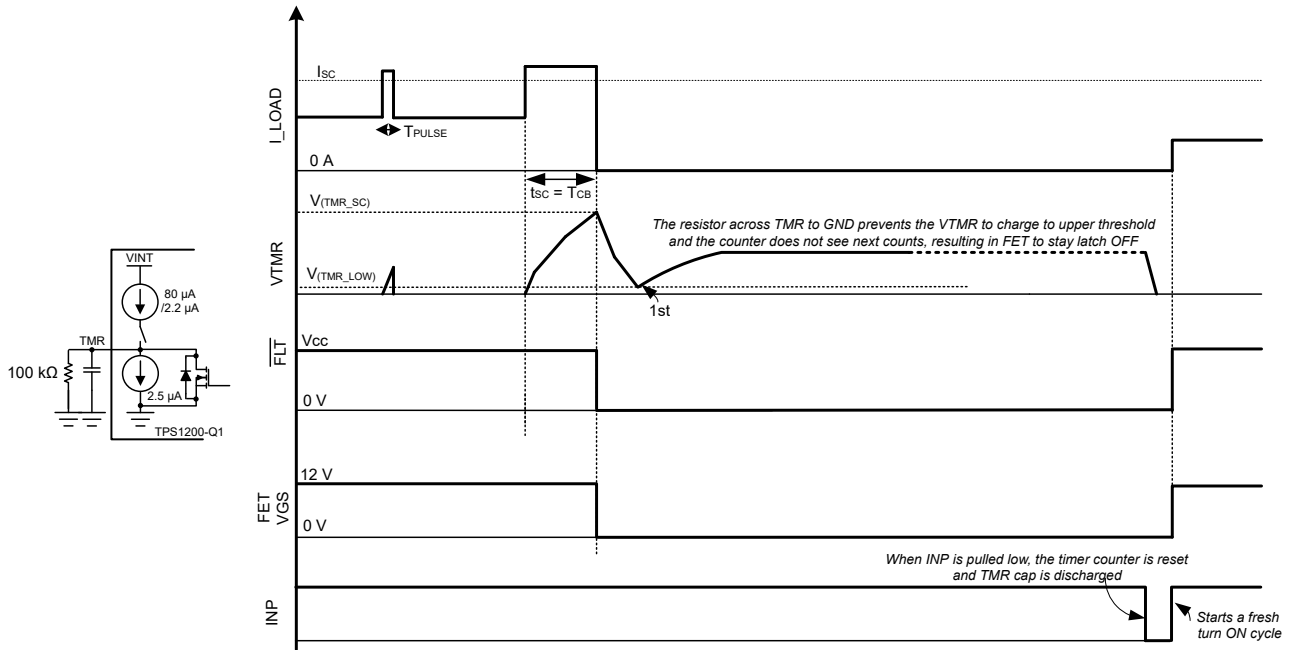

7-10. Short-Circuit Protection With Latch-Off

7.3.4 Overvoltage (OV) and Undervoltage Protection (UVLO)

TPS12000-Q1 has an accurate undervoltage protection ($< \pm 2\%$) using EN/UVLO pin and an accurate overvoltage protection ($< \pm 2\%$), providing robust load protection. Connect a resistor ladder as shown in 7-11 for undervoltage and overvoltage protection threshold programming.

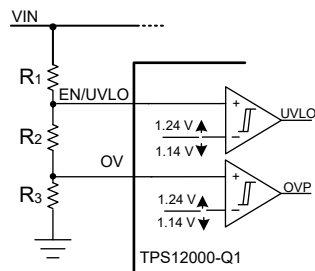

7-11. Programming Overvoltage and Undervoltage Protection Threshold

7.3.5 Reverse Polarity Protection

The TPS12000-Q1 devices features integrated reverse polarity protection to protect the device from failing during input and output reverse polarity faults. Reverse polarity faults can occur during jump start, installation and maintenance of the end equipment's.

The device is tolerant to reverse polarity voltages down to -40 V both on input and output.

On the output side, the device can see transient negative voltages during regular operation due to output cable harness inductance kickbacks when the switches are turned OFF. In such systems, the output negative voltage level is limited by the output side TVS or a diode.

7.3.6 Short-Circuit Protection Diagnosis (SCP_TEST)

In the safety critical designs, short-circuit protection (SCP) feature and its diagnosis is important.

The TPS12000-Q1 features the diagnosis of the internal short circuit protection. When SCP_TEST is driven low to high then, a voltage is applied internally across the SCP comparator inputs to simulate a short circuit event. The comparator output controls the gate drive (PU/PD) and also the FLT. If the gate drive goes low (with initially being high) and FLT also goes low then it indicates that the SCP is good otherwise it is to be treated as SCP feature is not functional.

If the SCP_TEST feature is not used, then connect SCP_TEST pin to GND.

7.3.7 TPS12000-Q1 as a Simple Gate Driver

Figure 7-12 shows application schematics of TPS12000-Q1 as a simple gate driver in load disconnect switch as well as back-to-back FETs driving topologies. The short-circuit protection feature is disabled.

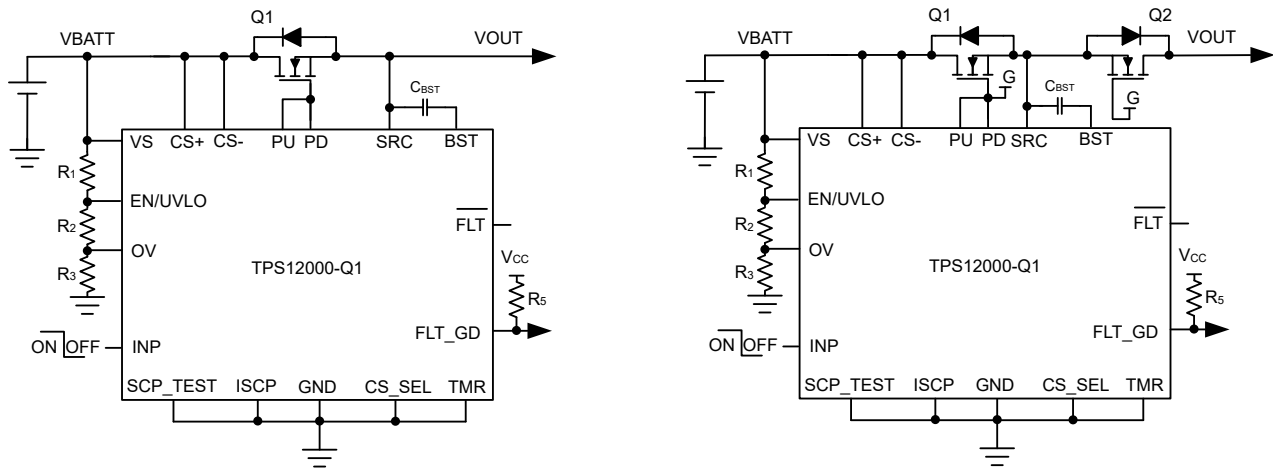

Figure 7-12. TPS12000-Q1 Application Circuit for Simple Gate Driver Design

7.4 Device Functional Modes

The TPS12000-Q1 has two modes of operation. Active mode and low IQ shutdown mode.

If the EN/UVLO pin voltage is greater than $V_{(ENR)}$ rising threshold, then the device is in active mode. In active state the internal charge pump is enabled, gate drivers, all the protection and diagnostic features are enabled.

If the EN/UVLO voltage is pulled below $V_{(ENF)}$ falling threshold, the device enters into low IQ shutdown mode. In this mode, the charge pump, gate drivers and all the protection features are disabled. The gate drive and external FETs turn OFF. The TPS12000-Q1 consumes low IQ of 1.5 μ A (typical) in this mode.

8 Application and Implementation

注

以下のアプリケーション情報は、TI の製品仕様に含まれるものではなく、TI ではその正確性または完全性を保証いたしません。個々の目的に対する製品の適合性については、お客様の責任で判断していただくこととなります。お客様は自身の設計実装を検証しテストすることで、システムの機能を確認する必要があります。

8.1 Application Information

The TPS12000-Q1 is a 45-V low IQ smart high side driver with protection and diagnostics. With wide operating voltage range of 3.5 V–40 V, the device is suitable for 12-V system designs. The device can withstand and protect the loads from negative supply voltages down to –40 V. It has strong 1.69-A/2-A peak source/sink gate driver enabling power switching using parallel FETs in high current system designs.

The device provides configurable short circuit protection using ISCP and TMR pins for adjusting the threshold and response time respectively. Auto-retry and latch-off fault behavior can be configured. With TPS12000-Q1, current sensing can be done either by an external sense resistor or by MOSFET VDS sensing. High or low side current sense resistor configuration is possible by using CS_SEL pin input.

Diagnosis of the integrated short circuit comparator can be done using external control on SCP_TEST input. The device indicates fault (FLT) on open drain output during during short circuit and input under voltage conditions. It also have a dedicate fault indication (FLT_GD) to indicate the gate drive UVLO condition.

Low Quiescent Current 43-μA operation enables always ON system designs. Quiescent current reduces to 1.5 μA (typical) with EN/UVLO low.

8.1.1 Application Limitations

This section highlights some limitations in the application which were identified during bench evaluation of the existing TPS12000-Q1 silicon on the evaluation module (EVM).

8.1.1.1 Short-Circuit Protection Delay

In application designs with high side current sense configurations as shown in [図 7-5](#) and [図 7-6](#) with C_{TMR} = Open, the short-circuit protection delay during power up with output short circuited does not match the specified maximum value of 10 μs.

Testing has shown that the actual short-circuit protection delay during power up by EN/UVLO signal is < 13 μs.

A design fix must be included in the final version of the IC.

8.1.1.2 Short-Circuit Protection Threshold

The minimum short-circuit protection threshold is limited to 30 mV.

A design update is planned in the final revision of the IC to extend the minimum threshold down to 20 mV. Due to the design update there will be a change of RSCP resistor formula and the revised formula will be as per the [式 9](#).

$$R_{ISCP}(\Omega) = \frac{(I_{SC} \times R_{SNS} - 19 \text{ mV})}{2 \mu\text{A}} \quad (9)$$

Lowest SCP threshold setting will be limited to 20 mV.

8.2 Typical Application: Driving Power at all Times (PAAT) Loads



図 8-1. TPS1200-Q1 Application Circuit for driving PAAT loads with VDS based Current Sensing

8.2.1 Design Requirements

表 8-1. Design Parameters

| PARAMETER | VALUE |
|---|------------|
| Input Voltage Range, V_{IN} | 8 to 16V |
| Undervoltage lockout set point, $V_{IN_{UVLO}}$ | 6.5V |
| Overvoltage set point, $V_{IN_{OVP}}$ | 36V |
| Maximum load current, I_{OUT} | 30A |
| Short-circuit protection threshold, I_{SC} | 100A |
| Fault timer period, t_{SC} | 50 μ s |
| Fault response | Auto-Retry |
| Current sensing | MOSFET VDS |

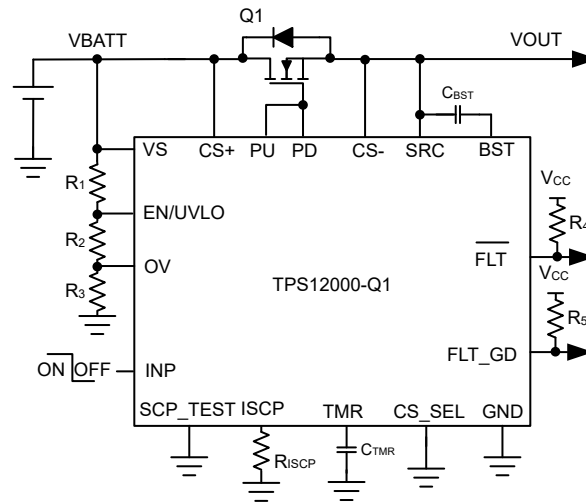
8.2.2 Detailed Design Procedure

Selection of MOSFET, Q₁

For selecting the MOSFET Q₁, important electrical parameters are the maximum continuous drain current I_D, the maximum drain-to-source voltage V_{DS(MAX)}, the maximum drain-to-source voltage V_{GS(MAX)}, and the drain-to-source ON resistance R_{DS(ON)}.

The maximum continuous drain current, I_D, rating must exceed the maximum continuous load current.

The maximum drain-to-source voltage, V_{DS(MAX)}, must be high enough to withstand the highest voltage seen in the application. Considering 35 V as the maximum application voltage due to load dump, MOSFETs with V_{DS} voltage rating of 40 V is chosen for this application.

The maximum V_{GS} TPS1200-Q1 can drive is 11 V, so a MOSFET with 15-V minimum V_{GS} rating must be selected.

To reduce the MOSFET conduction losses, an appropriate R_{DS(ON)} is preferred.

Based on the design requirements, BUK7J1R4-40H is selected and its ratings are:

- 40-V V_{DS(MAX)} and ±20-V V_{GS(MAX)}
- R_{DS(ON)} is 1.06-mΩ typical at 10-V V_{GS}
- MOSFET Q_{g(total)} is 73 nC typical

TI recommends to make sure that the short-circuit conditions such max V_{IN} and I_{SC} are within SOA of selected FET (Q₁) for at-least > t_{SC} timing.

Selection of Bootstrap Capacitor, C_{BST}

The internal charge pump charges the external bootstrap capacitor (connected between BST and SRC pins) with approximately 345 μA. Use the following equation to calculate the minimum required value of the bootstrap capacitor for driving BUK7J1R4-40H MOSFET

$$C_{BST} = \frac{Q_{g(\text{total})}}{1V} = 73 \text{ nF} \quad (10)$$

Choose closest available standard value: 100 nF, 10 %.

Programming the Short-Circuit Protection Threshold – R_{ISCP} Selection

The R_{ISCP} sets the short-circuit protection threshold, whose value can be calculated using below equation:

$$R_{ISCP} (\Omega) = \frac{(I_{SC} \times R_{DS_ON} - 10 \text{ mV})}{2 \mu\text{A}} \quad (11)$$

Refer to 式 9 in セクション 8.1.1 section for update in equation in final revision of IC.

To set 100 A as short-circuit protection threshold, R_{ISCP} value is calculated to be 45 kΩ.

Choose the closest available standard value: 45.2 kΩ, 1%.

In case where large di/dt is involved, the system and layout parasitic inductances can generate large differential signal voltages between CS+ and CS- pins. This action can trigger false short-circuit protection and nuisance trips in the system. To overcome such scenario, TI suggests to add placeholder for RC filter components across sense resistor (R_{SNS}) and tweak the values during test in the real system. The RC filter components should not be used in current sense designs by MOSFET V_{DS} sensing to avoid impact on the short-circuit protection response.

Programming the Fault timer Period – C_{TMR} Selection

For the design example under discussion, overcurrent transients are allowed for 50- μ s duration. This blanking interval, t_{SC} (or circuit breaker interval, T_{CB}) can be set by selecting appropriate capacitor C_{TMR} from TMR pin to ground. The value of C_{TMR} to set 50 μ s for t_{SC} can be calculated using following equation:

$$C_{TMR} = \frac{80 \mu A \times t_{SC}}{1.1} \quad (12)$$

Choose closest available standard value: 3.3 nF, 10 %.

Setting the Undervoltage Lockout and Overvoltage Set Point

The undervoltage lockout (UVLO) and overvoltage set point are adjusted using an external voltage divider network of R_1 , R_2 and R_3 connected between VS, EN/UVLO, OV and GND pins of the device. The values required for setting the undervoltage and overvoltage are calculated by solving 式 13 and 式 14.

$$V_{(OVR)} = \frac{R_3}{(R_1 + R_2 + R_3)} \times V_{IN_{OVP}} \quad (13)$$

$$V_{(UVLOR)} = \frac{R_2 + R_3}{(R_1 + R_2 + R_3)} \times V_{IN_{UVLO}} \quad (14)$$

For minimizing the input current drawn from the power supply, TI recommends to use higher values of resistance for R_1 , R_2 and R_3 . However, leakage currents due to external active components connected to the resistor string can add error to these calculations. So, the resistor string current, $I(R_{123})$ must be chosen to be 20 times greater than the leakage current of UVLO and OV pins.

From the device electrical specifications, $V_{(OVR)} = 1.24$ V and $V_{(UVLOR)} = 1.24$ V. From the design requirements, $V_{IN_{OVP}}$ is 36 V and $V_{IN_{UVLO}}$ is 6.5 V. To solve the equation, first choose the value of $R_1 = 470$ k Ω and use 式 13 to solve for $(R_2 + R_3) = 108.3$ k Ω . Use 式 14 and value of $(R_2 + R_3)$ to solve for $R_3 = 19.6$ k Ω and finally $R_2 = 88.7$ k Ω . Choose the closest standard 1 % resistor values: $R_1 = 470$ k Ω , $R_2 = 88.7$ k Ω , and $R_3 = 19.6$ k Ω .

8.2.3 Application Curves

ADVANCE INFORMATION

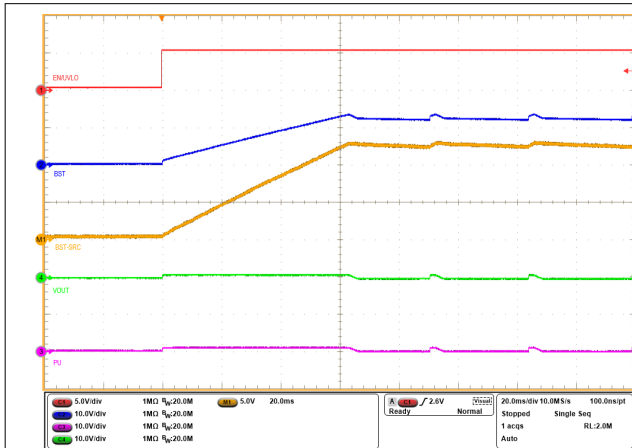

8-2. Start-Up Profile of Bootstrap Voltage with INP = GND and $C_{BST} = 470$ nF

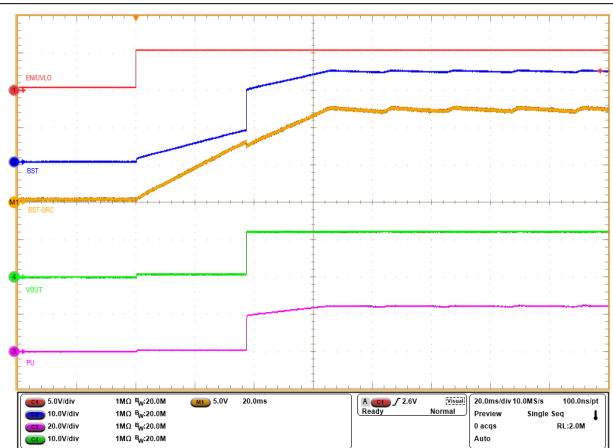

8-3. Start-Up Profile of Bootstrap Voltage with INP = HIGH and $C_{BST} = 470$ nF

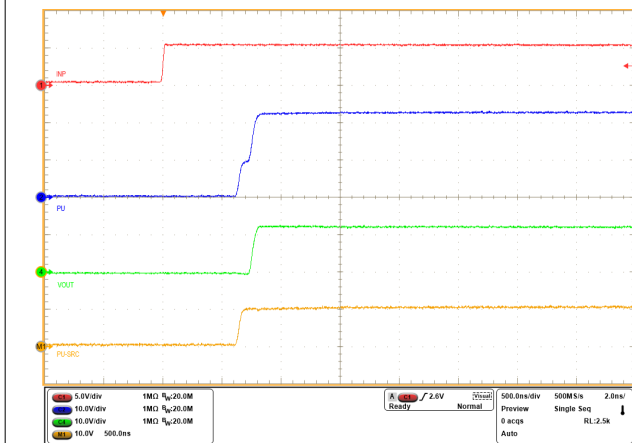

8-4. Turn-ON Response of TPS1200-Q1 for INP -> LOW to HIGH and $C_{BST} = 470$ nF

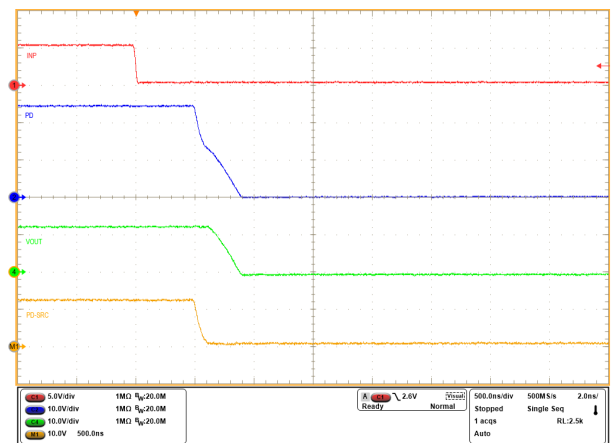

8-5. Turn-OFF Response of TPS1200-Q1 for INP -> HIGH to LOW and $C_{BST} = 470$ nF

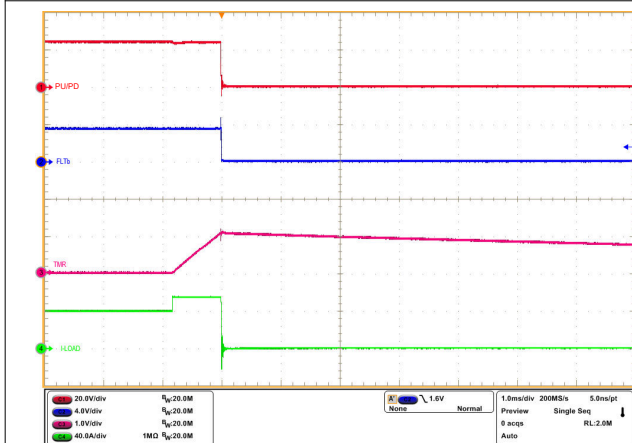

8-6. Overcurrent Response of TPS1200-Q1 for a Load Step from 40 A to 55 A with 50-A Shortcircuit Protection Setting and $t_{sc} = 1$ ms

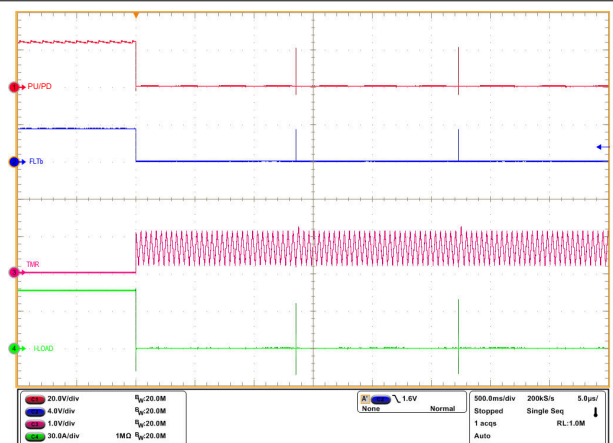

8-7. Auto-Retry Response of TPS1200-Q1 for an Overcurrent Fault

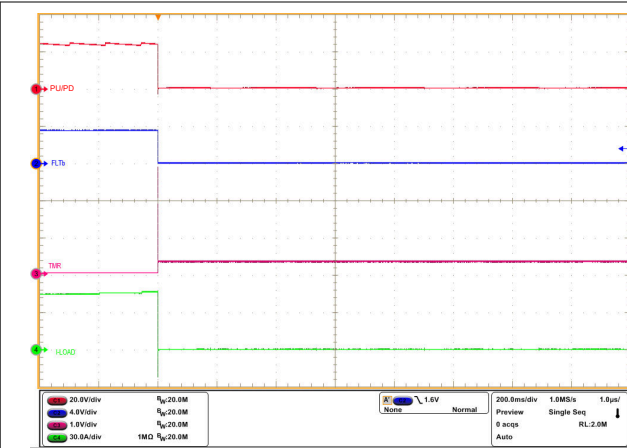

8-8. Latch-Off Response of TPS1200-Q1 for an Overcurrent Fault

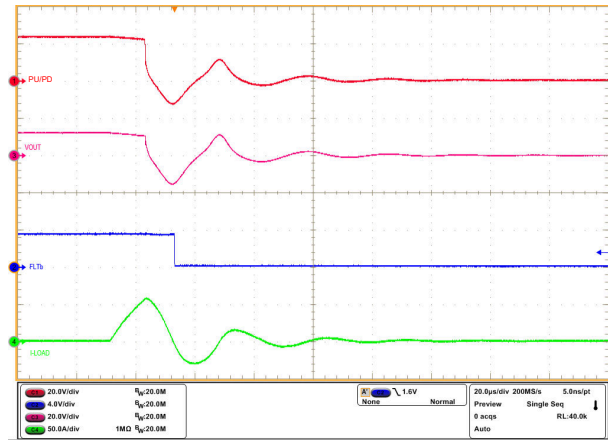

8-9. Output Short-Circuit Response of TPS1200-Q1 Device with 50-A Shortcircuit Protection Setting and TMR = OPEN

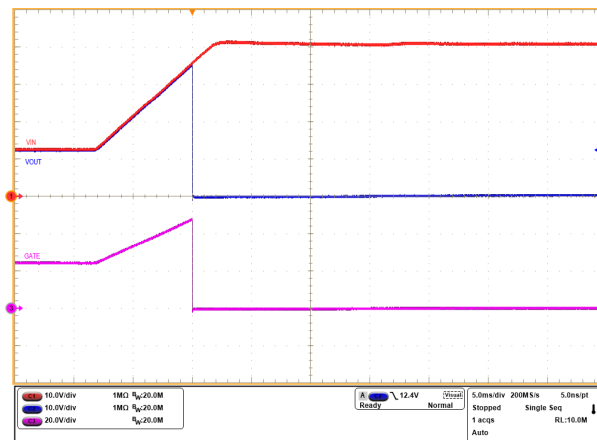

8-10. Overvoltage Cutoff Response of TPS1200-Q1 at 36-V Level

8.3 Power Supply Recommendations

When the external MOSFETs turn-OFF during the conditions such as INP1 control, overcurrent protection causing an interruption of the current flow, the input parasitic line inductance generates a positive voltage spike on the input and output parasitic inductance generates a negative voltage spike on the output. The peak amplitude of voltage spikes (transients) depends on the value of inductance in series to the input or output of the device. These transients can exceed the [セクション 5.1](#) of the device if steps are not taken to address the issue. Typical methods for addressing transients include:

- Use of a TVS diode and input capacitor filter combination across input to and GND to absorb the energy and dampen the positive transients.
- Use of a diode or a TVS diode across the output and GND to absorb negative spikes.

The TPS1200-Q1 gets powered from the VS pin. Voltage at this pin must be maintained above $V_{(VS_PORR)}$ level to ensure proper operation. If the input power supply source is noisy with transients, then TI recommends to place a $R_{VS} - C_{VS}$ filter between the input supply line and VS pin to filter out the supply noise. TI recommends R_{VS} value around 100 Ω .

In case where large di/dt is involved, the system and layout parasitic inductances can generate large differential signal voltages between CS+ and CS- pins. This action can trigger false short-circuit protection and nuisance trips in the system. To overcome such scenario, TI suggests to add placeholder for RC filter components across

sense resistor (R_{SNS}) and tweak the values during test in the real system. The RC filter components must not be used in current sense designs by MOSFET VDS sensing to avoid impact on the short-circuit protection response.

The following figure shows the circuit implementation with optional protection components.

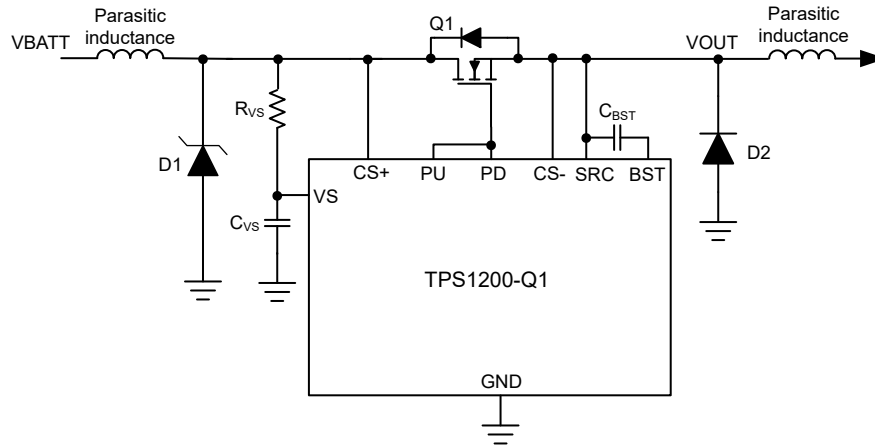

Figure 8-11. Circuit Implementation With Optional Protection Components For TPS1200-Q1

8.4 Layout

8.4.1 Layout Guidelines

- Place the sense resistor (R_{SNS}) close to the TPS1200-Q1 and then connect R_{SNS} using the Kelvin techniques. Refer to [Choosing the Right Sense Resistor Layout](#) for more information on the Kelvin techniques.

For VDS based Current Sensing, follow the same kevin techniques across the MOSFET.

- Choose a 0.1 μF or higher value ceramic decoupling capacitor between VS terminal and GND for all the applications. Consider adding RC network at the supply pin (VS) of the controller to improve decoupling against the power line disturbances.
- Make the high-current path from the board input to the load, and the return path, parallel and close to each other to minimize loop inductance.
- Place the external MOSFETs close to the controller GATE drive pins (PU/PD) such that the GATE of the MOSFETs are close to the controller GATE drive pins and forms a shorter GATE loop. Consider adding a place holder for a resistor in series with the Gate of each external MOSFET to damp high frequency oscillations if need arises.
- Place a TVS diode at the input to clamp the voltage transients during hot-plug and fast turn-off events.
- Place the external boot-strap capacitor close to BST and SRC pins to form very short loop.
- Connect the ground connections for the various components around the TPS1200-Q1 directly to each other, and to the TPS1200-Q1 GND, and then connected to the system ground at one point. Do not connect the various component grounds to each other through the high current ground line.

8.4.2 Layout Example

- Top Layer
- Inner Layer GND plane
- Inner Layer PGND plane
- Via to GND plane
- Via to PGND plane

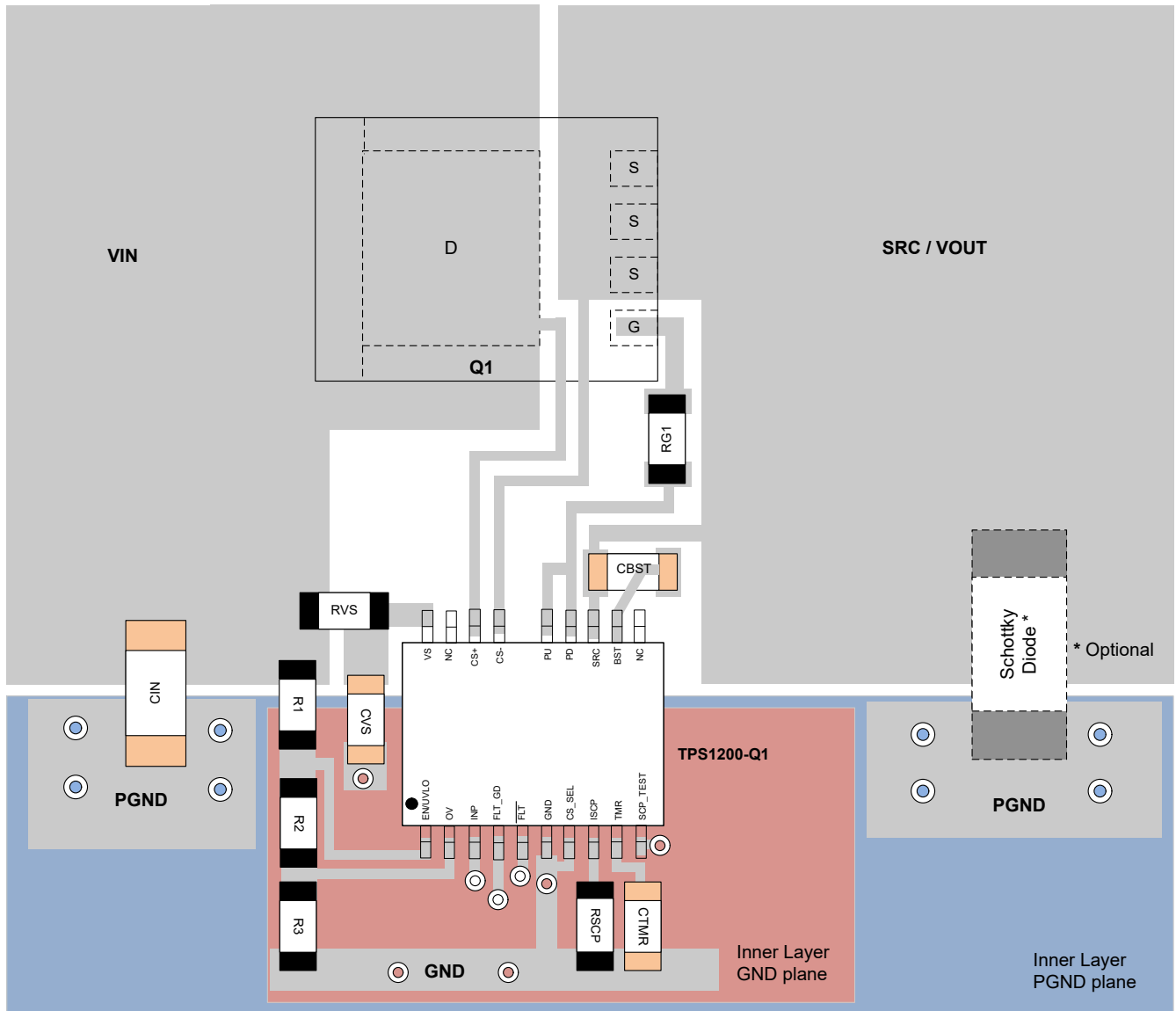

ADVANCE INFORMATION

8-12. Typical PCB Layout Example for TPS1200-Q1 With VDS based Current Sensing

9 Device and Documentation Support

9.1 ドキュメントの更新通知を受け取る方法

ドキュメントの更新についての通知を受け取るには、www.tij.co.jp のデバイス製品フォルダを開いてください。[通知] をクリックして登録すると、変更されたすべての製品情報に関するダイジェストを毎週受け取ることができます。変更の詳細については、改訂されたドキュメントに含まれている改訂履歴をご覧ください。

9.2 サポート・リソース

テキサス・インスツルメンツ E2E™ サポート・フォーラムは、エンジニアが検証済みの回答と設計に関するヒントをエキスパートから迅速かつ直接得ることができる場所です。既存の回答を検索したり、独自の質問をしたりすることで、設計に必要な支援を迅速に得ることができます。

リンクされているコンテンツは、各寄稿者により「現状のまま」提供されるものです。これらはテキサス・インスツルメンツの仕様を構成するものではなく、必ずしもテキサス・インスツルメンツの見解を反映したものではありません。テキサス・インスツルメンツの[使用条件](#)を参照してください。

9.3 Trademarks

テキサス・インスツルメンツ E2E™ is a trademark of Texas Instruments.
すべての商標は、それぞれの所有者に帰属します。

9.4 静電気放電に関する注意事項



この IC は、ESD によって破損する可能性があります。テキサス・インスツルメンツは、IC を取り扱う際には常に適切な注意を払うことを推奨します。正しい取り扱いおよび設置手順に従わない場合、デバイスを破損するおそれがあります。

ESD による破損は、わずかな性能低下からデバイスの完全な故障まで多岐にわたります。精密な IC の場合、パラメータがわずかに変化するだけで公表されている仕様から外れる可能性があるため、破損が発生しやすくなっています。

9.5 用語集

[テキサス・インスツルメンツ用語集](#) この用語集には、用語や略語の一覧および定義が記載されています。

10 Revision History

資料番号末尾の英字は改訂を表しています。その改訂履歴は英語版に準じています。

| DATE | REVISION | NOTES |
|---------------|----------|-----------------|
| December 2023 | * | Initial Release |

11 Mechanical, Packaging, and Orderable Information

The following pages include mechanical, packaging, and orderable information. This information is the most current data available for the designated devices. This data is subject to change without notice and revision of this document. For browser-based versions of this data sheet, refer to the left-hand navigation.

11.1 Tape and Reel Information

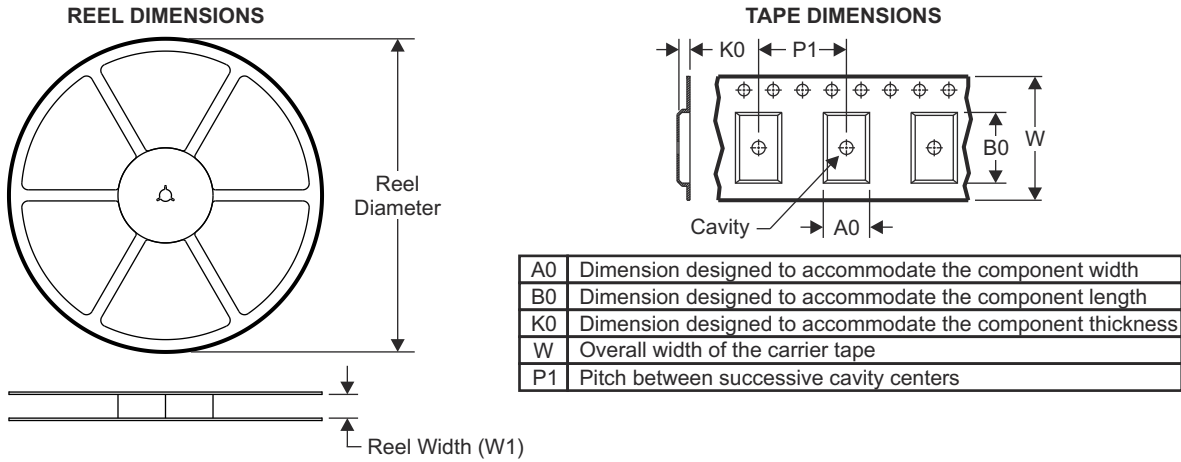

QUADRANT ASSIGNMENTS FOR PIN 1 ORIENTATION IN TAPE

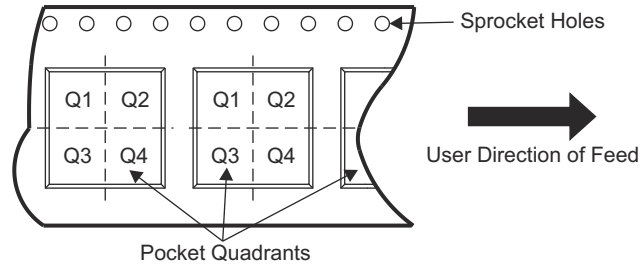

| Device | Package Type | Package Drawing | Pins | SPQ | Reel Diameter (mm) | Reel Width W1 (mm) | A0 (mm) | B0 (mm) | K0 (mm) | P1 (mm) | W (mm) | Pin1 Quadrant |
|------------------|--------------|-----------------|------|------|--------------------|--------------------|---------|---------|---------|---------|--------|---------------|
| PTPS12000QDGXRQ1 | VSSOP | DGX | 19 | 5000 | 330.0 | 16.0 | 5.40 | 5.40 | 1.45 | 8.0 | 12.0 | Q1 |

ADVANCE INFORMATION

TAPE AND REEL BOX DIMENSIONS

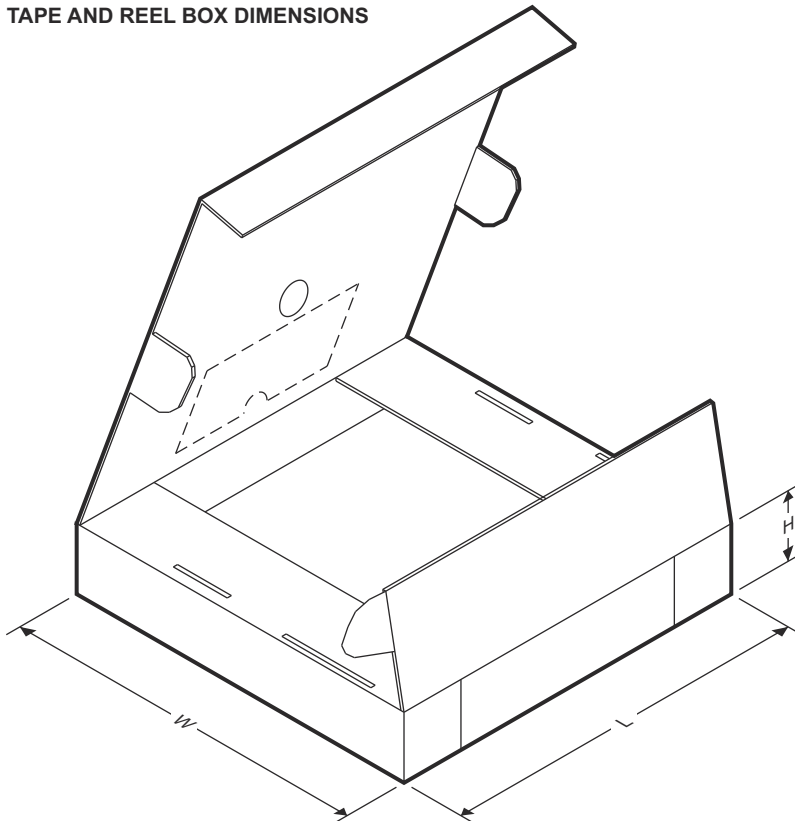

| Device | Package Type | Package Drawing | Pins | SPQ | Length (mm) | Width (mm) | Height (mm) |
|------------------|--------------|-----------------|------|------|-------------|------------|-------------|
| PTPS12000QDGXRQ1 | VSSOP | DGX | 19 | 5000 | 853.0 | 449.0 | 35.0 |

ADVANCE INFORMATION

PACKAGING INFORMATION

| Orderable Device | Status (1) | Package Type | Package Drawing | Pins | Package Qty | Eco Plan (2) | Lead finish/ Ball material (6) | MSL Peak Temp (3) | Op Temp (°C) | Device Marking (4/5) | Samples |
|------------------|---------------|--------------|-----------------|------|-------------|-----------------|--------------------------------------|----------------------|--------------|-------------------------|---------|
| PTPS12000QDGXRQ1 | ACTIVE | VSSOP | DGX | 19 | 5000 | TBD | Call TI | Call TI | -40 to 125 | | Samples |

(1) The marketing status values are defined as follows:

ACTIVE: Product device recommended for new designs.

LIFEBUY: TI has announced that the device will be discontinued, and a lifetime-buy period is in effect.

NRND: Not recommended for new designs. Device is in production to support existing customers, but TI does not recommend using this part in a new design.

PREVIEW: Device has been announced but is not in production. Samples may or may not be available.

OBSOLETE: TI has discontinued the production of the device.

(2) **RoHS:** TI defines "RoHS" to mean semiconductor products that are compliant with the current EU RoHS requirements for all 10 RoHS substances, including the requirement that RoHS substance do not exceed 0.1% by weight in homogeneous materials. Where designed to be soldered at high temperatures, "RoHS" products are suitable for use in specified lead-free processes. TI may reference these types of products as "Pb-Free".

RoHS Exempt: TI defines "RoHS Exempt" to mean products that contain lead but are compliant with EU RoHS pursuant to a specific EU RoHS exemption.

Green: TI defines "Green" to mean the content of Chlorine (Cl) and Bromine (Br) based flame retardants meet JS709B low halogen requirements of <=1000ppm threshold. Antimony trioxide based flame retardants must also meet the <=1000ppm threshold requirement.

(3) MSL, Peak Temp. - The Moisture Sensitivity Level rating according to the JEDEC industry standard classifications, and peak solder temperature.

(4) There may be additional marking, which relates to the logo, the lot trace code information, or the environmental category on the device.

(5) Multiple Device Markings will be inside parentheses. Only one Device Marking contained in parentheses and separated by a "~" will appear on a device. If a line is indented then it is a continuation of the previous line and the two combined represent the entire Device Marking for that device.

(6) Lead finish/Ball material - Orderable Devices may have multiple material finish options. Finish options are separated by a vertical ruled line. Lead finish/Ball material values may wrap to two lines if the finish value exceeds the maximum column width.

Important Information and Disclaimer:The information provided on this page represents TI's knowledge and belief as of the date that it is provided. TI bases its knowledge and belief on information provided by third parties, and makes no representation or warranty as to the accuracy of such information. Efforts are underway to better integrate information from third parties. TI has taken and continues to take reasonable steps to provide representative and accurate information but may not have conducted destructive testing or chemical analysis on incoming materials and chemicals. TI and TI suppliers consider certain information to be proprietary, and thus CAS numbers and other limited information may not be available for release.

In no event shall TI's liability arising out of such information exceed the total purchase price of the TI part(s) at issue in this document sold by TI to Customer on an annual basis.

DGX0019A



PACKAGE OUTLINE

VSSOP - 1.1 mm max height

SMALL OUTLINE PACKAGE

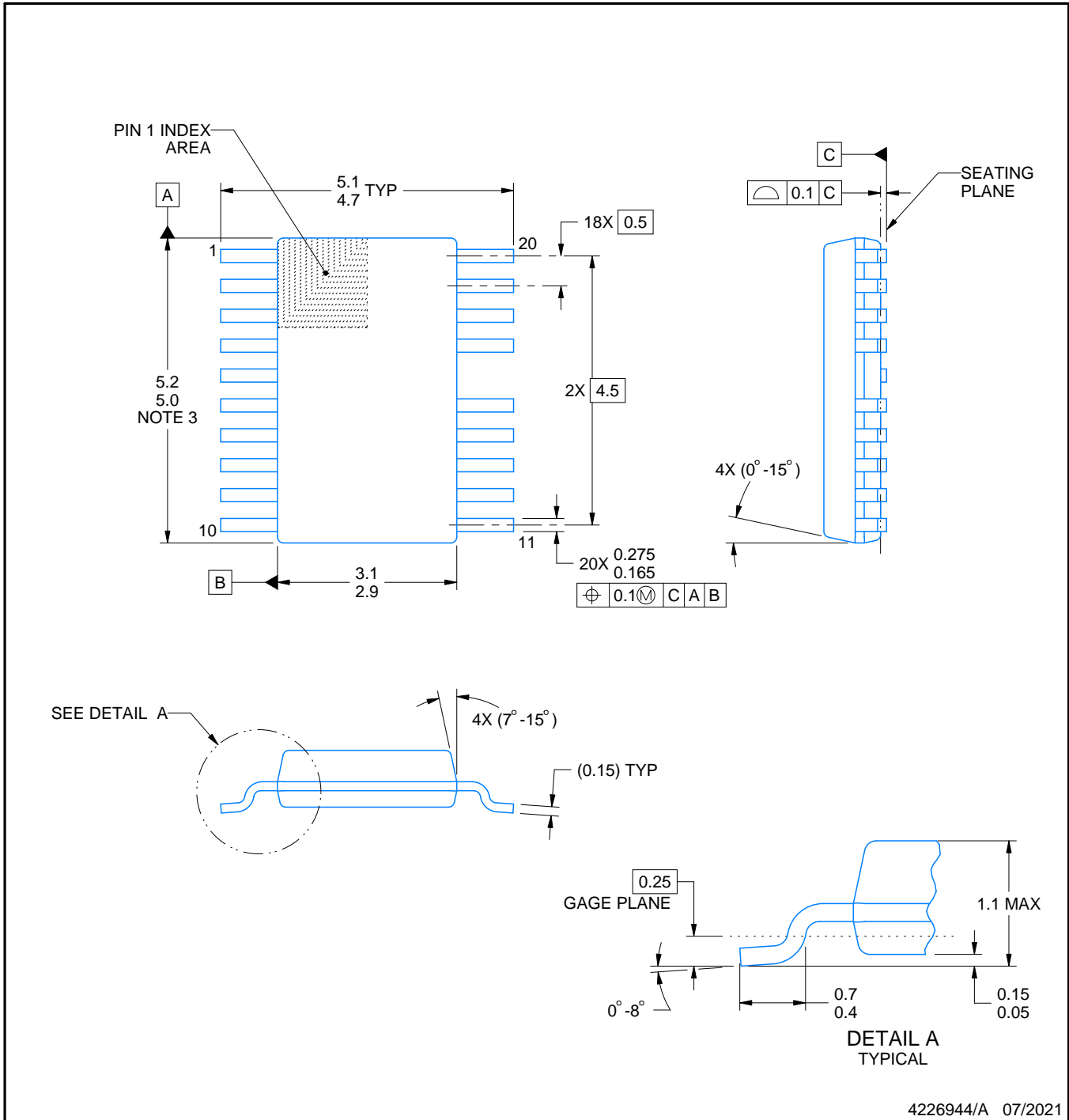

4226944/A 07/2021

NOTES:

PowerPAD is a trademark of Texas Instruments.

- All linear dimensions are in millimeters. Any dimensions in parenthesis are for reference only. Dimensioning and tolerancing per ASME Y14.5M.
- This drawing is subject to change without notice.
- This dimension does not include mold flash, protrusions, or gate burrs. Mold flash, protrusions, or gate burrs shall not exceed 0.15 mm per side.
- No JEDEC registration as of July 2021.
- Features may differ or may not be present.

EXAMPLE BOARD LAYOUT

DGX0019A

VSSOP - 1.1 mm max height

SMALL OUTLINE PACKAGE

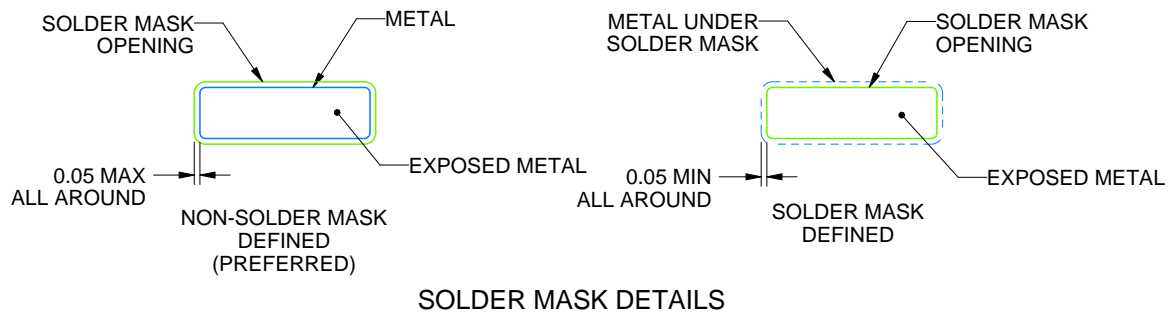
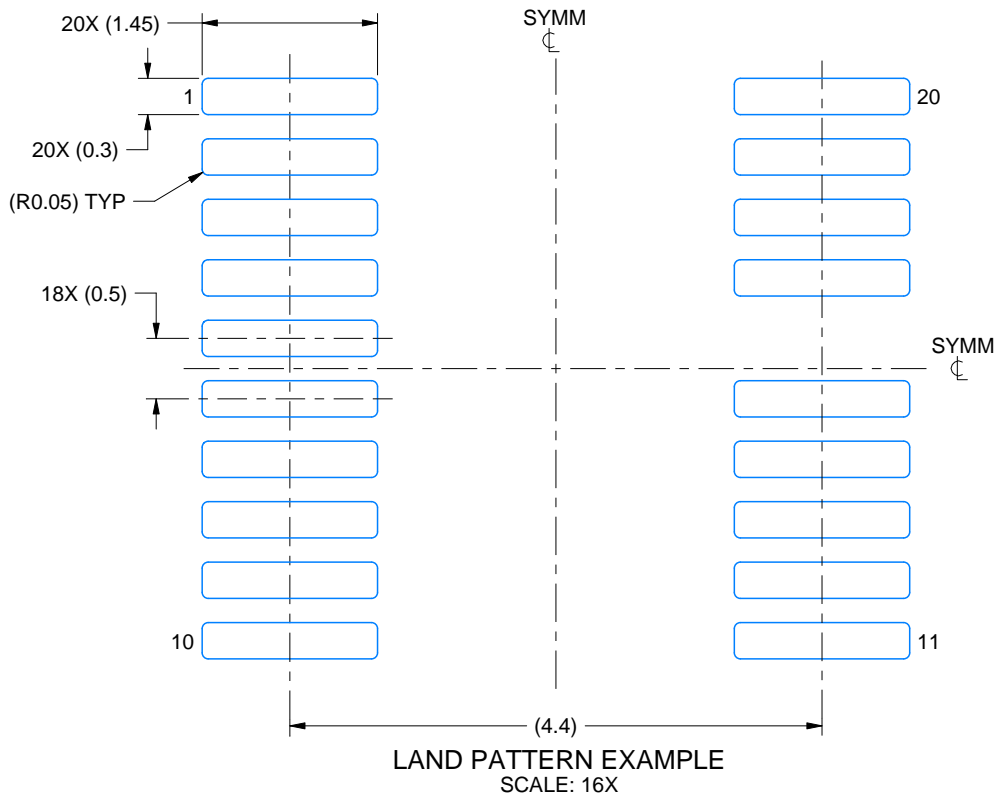

4226944/A 07/2021

NOTES: (continued)

6. Publication IPC-7351 may have alternate designs.
7. Solder mask tolerances between and around signal pads can vary based on board fabrication site.
8. This package is designed to be soldered to a thermal pad on the board. For more information, see Texas Instruments literature numbers SLMA002 (www.ti.com/lit/slma002) and SLMA004 (www.ti.com/lit/slma004).
9. Size of metal pad may vary due to creepage requirement.
10. Vias are optional depending on application, refer to device data sheet. It is recommended that vias under paste be filled, plugged or tented.

EXAMPLE STENCIL DESIGN

DGX0019A

VSSOP - 1.1 mm max height

SMALL OUTLINE PACKAGE

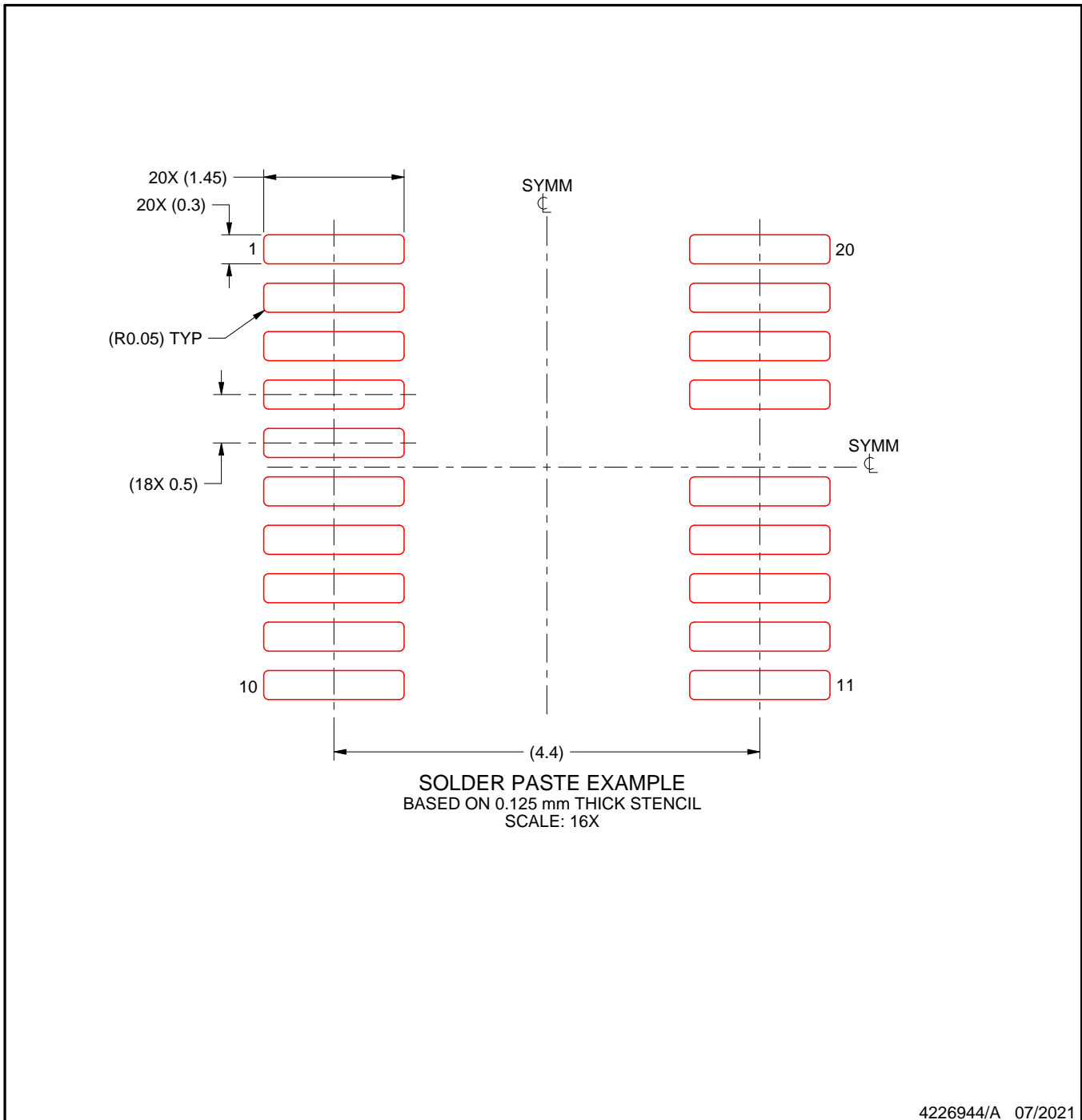

NOTES: (continued)

11. Laser cutting apertures with trapezoidal walls and rounded corners may offer better paste release. IPC-7525 may have alternate design recommendations.
12. Board assembly site may have different recommendations for stencil design.

重要なお知らせと免責事項

TI は、技術データと信頼性データ (データシートを含みます)、設計リソース (リファレンス・デザインを含みます)、アプリケーションや設計に関する各種アドバイス、Web ツール、安全性情報、その他のリソースを、欠陥が存在する可能性のある「現状のまま」提供しており、商品性および特定目的に対する適合性の黙示保証、第三者の知的財産権の非侵害保証を含むいかなる保証も、明示的または黙示的にかかわらず拒否します。

これらのリソースは、TI 製品を使用する設計の経験を積んだ開発者への提供を意図したものです。(1) お客様のアプリケーションに適した TI 製品の選定、(2) お客様のアプリケーションの設計、検証、試験、(3) お客様のアプリケーションに該当する各種規格や、その他のあらゆる安全性、セキュリティ、規制、または他の要件への確実な適合に関する責任を、お客様のみが単独で負うものとします。

上記の各種リソースは、予告なく変更される可能性があります。これらのリソースは、リソースで説明されている TI 製品を使用するアプリケーションの開発の目的でのみ、TI はその使用をお客様に許諾します。これらのリソースに関して、他の目的で複製することや掲載することは禁止されています。TI や第三者の知的財産権のライセンスが付与されている訳ではありません。お客様は、これらのリソースを自身で使用した結果発生するあらゆる申し立て、損害、費用、損失、責任について、TI およびその代理人を完全に補償するものとし、TI は一切の責任を拒否します。

TI の製品は、[TI の販売条件](#)、または [ti.com](#) やかかる TI 製品の関連資料などのいずれかを通じて提供する適用可能な条項の下で提供されています。TI がこれらのリソースを提供することは、適用される TI の保証または他の保証の放棄の拡大や変更を意味するものではありません。

お客様がいかなる追加条項または代替条項を提案した場合でも、TI はそれらに異議を唱え、拒否します。

郵送先住所 : Texas Instruments, Post Office Box 655303, Dallas, Texas 75265
Copyright © 2024, Texas Instruments Incorporated