

TPS36-Q1 車載用 Nano IQ 高精度電圧監視回路、高精度ウィンドウ・ウォッチドッグ・タイマ付き

1 特長

- 下記内容で AEC-Q100 認定済み
 - デバイス温度グレード 1:動作時周囲温度範囲: $-40^{\circ}\text{C}\sim 125^{\circ}\text{C}$
- 工場出荷時にプログラム済みまたはユーザーがプログラム可能なウォッチドッグ・タイムアウト
 - $\pm 10\%$ 精度のタイマ (最大値)
 - 工場出荷時にプログラム済みのクローズ・ウィンドウ: $1\text{msec}\sim 100\text{sec}$
- 工場出荷時にプログラム済みまたはユーザーがプログラム可能なリセット遅延
 - $\pm 10\%$ 精度のタイマ (最大値)
 - 工場出荷時にプログラム済みのオプション: $2\text{msec}\sim 10\text{sec}$
- 入力電圧範囲: $V_{\text{DD}} = 1.04\text{V}\sim 6.0\text{V}$
- 固定スレッショルド電圧 (V_{IT}): $1.05\text{V}\sim 5.4\text{V}$
 - スレッショルド電圧は 50mV 刻みで利用可能
 - 1.2% の電圧スレッショルド精度 (最大値)
 - ヒステリシス内蔵 (V_{HYS}): 5% (標準値)
- 超低電源電流: $I_{\text{DD}} = 250\text{nA}$ (標準値)
- オープン・ドレイン、プッシュプル、アクティブ Low 出力
- 各種のプログラマビリティ・オプション:
 - ウォッチドッグ・イネーブル / ディセーブル
 - ウォッチドッグ・スタートアップ遅延: 遅延なし ~ 10 秒
 - オープン・ウィンドウとクローズ・ウィンドウの比率オプション: 1 倍 ~ 511 倍
 - ラッチ付き出力オプション
- $\overline{\text{MR}}$ 機能のサポート

2 アプリケーション

- オンボード・チャージャ (OBC) およびワイヤレス・チャージャ
- ドライバー監視
- バッテリー管理システム (BMS)
- フロント・カメラ
- サラウンド・ビュー・システムの ECU

3 概要

TPS36-Q1 は、超低消費電力 (標準値 250nA) のデバイスであり、高精度電圧監視回路を備え、プログラム可能なウィンドウ・ウォッチドッグ・タイマを搭載しています。TPS36-Q1 は、低電圧監視のための広いスレッショルド・レベルをサポートしており、規定された温度範囲全体にわたって 1.2% の精度を達成しています。

TPS36-Q1 は、さまざまなアプリケーションに対応する多くの機能を備えた高精度ウィンドウ・ウォッチドッグ・タイマを提供します。クローズ・ウィンドウ・タイマは、工場出荷時にプログラムするか、または、外付けコンデンサを使用してユーザーがプログラムするか、いずれかが可能です。オープン・ウィンドウとクローズ・ウィンドウの比率は、ロジック・ピンの組み合わせを使用して動作中でも変更できます。また、このウォッチドッグは、イネーブル / ディセーブル、スタートアップ遅延、独立 WDO ピン・オプションなどの独自の機能も備えています。

$\overline{\text{RESET}}$ または $\overline{\text{WDO}}$ 遅延は、工場出荷時にプログラムされるデフォルトの遅延設定で設定するか、または外付けコンデンサでプログラムできます。また、このデバイスはラッチ付き出力動作も備えており、監視回路またはウォッチドッグのフォルトがクリアされるまで出力がラッチされます。

TPS36-Q1 は、TPS3852-Q1 デバイス・ファミリに代わる性能アップグレード製品です。TPS36-Q1 は、小型の 8 ピン SOT-23 パッケージで供給されます。

製品情報

部品番号	パッケージ (1)	本体サイズ (公称)
TPS36-Q1	DDF (8)	2.90mm × 1.60mm

- (1) 利用可能なすべてのパッケージについては、このデータシートの末尾にある注文情報を参照してください。



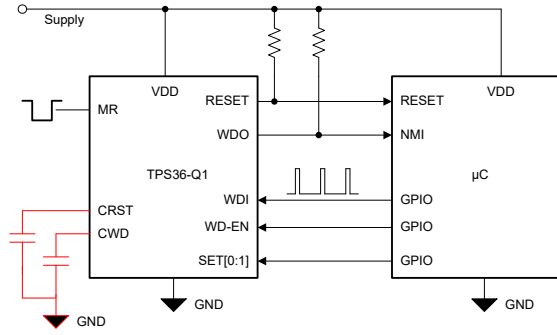

TPS36-Q1 offers various pinout options to support different features.
Choose suitable pinout based on application needs

代表的なアプリケーション回路

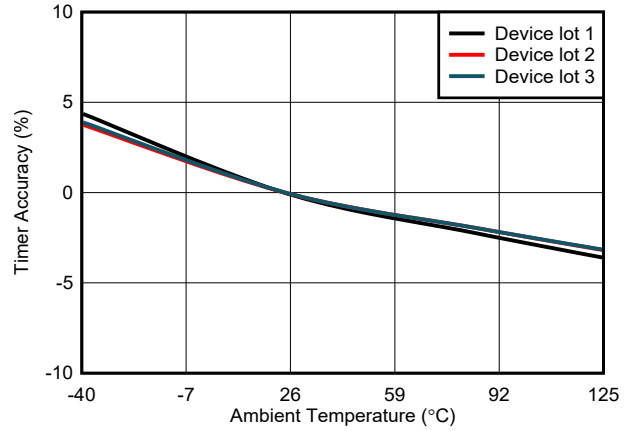

Table of Contents

<p>1 特長..... 1</p> <p>2 アプリケーション..... 1</p> <p>3 概要..... 1</p> <p>4 Revision History..... 3</p> <p>5 デバイスの比較..... 4</p> <p>6 Pin Configuration and Functions..... 5</p> <p>7 Specifications..... 7</p> <p style="padding-left: 20px;">7.1 Absolute Maximum Ratings..... 7</p> <p style="padding-left: 20px;">7.2 ESD Ratings 7</p> <p style="padding-left: 20px;">7.3 Recommended Operating Conditions..... 7</p> <p style="padding-left: 20px;">7.4 Thermal Information..... 8</p> <p style="padding-left: 20px;">7.5 Electrical Characteristics 9</p> <p style="padding-left: 20px;">7.6 Timing Requirements 10</p> <p style="padding-left: 20px;">7.7 Switching Characteristics 11</p> <p style="padding-left: 20px;">7.8 Timing Diagrams..... 12</p> <p style="padding-left: 20px;">7.9 Typical Characteristics..... 13</p> <p>8 Detailed Description..... 16</p>	<p>8.1 Overview..... 16</p> <p>8.2 Functional Block Diagrams..... 16</p> <p>8.3 Feature Description..... 17</p> <p>8.4 Device Functional Modes..... 26</p> <p>9 Application and Implementation..... 27</p> <p style="padding-left: 20px;">9.1 Application Information..... 27</p> <p style="padding-left: 20px;">9.2 Typical Applications..... 28</p> <p style="padding-left: 20px;">9.3 Power Supply Recommendations..... 30</p> <p style="padding-left: 20px;">9.4 Layout..... 30</p> <p>10 Device and Documentation Support..... 31</p> <p style="padding-left: 20px;">10.1 ドキュメントの更新通知を受け取る方法..... 31</p> <p style="padding-left: 20px;">10.2 サポート・リソース..... 31</p> <p style="padding-left: 20px;">10.3 Trademarks..... 32</p> <p style="padding-left: 20px;">10.4 静電気放電に関する注意事項..... 32</p> <p style="padding-left: 20px;">10.5 用語集..... 32</p> <p>11 Mechanical, Packaging, and Orderable Information..... 32</p>
---	--

4 Revision History

資料番号末尾の英字は改訂を表しています。その改訂履歴は英語版に準じています。

Changes from Revision * (November 2022) to Revision A (December 2022)	Page
• 事前情報から量産データのリリースに変更.....	1

5 デバイスの比較

図 5-1 に、TPS36-Q1 のデバイス命名規則を示します。可能なすべての出力タイプ、スレッショルド電圧オプション、ウォッチドッグ時間オプション、および出力アサート遅延オプションの詳細については、[セクション 8](#) を参照してください。他のオプションの詳細と提供状況については、TI の販売代理店または TI の [E2E フォーラム](#) にお問い合わせください。

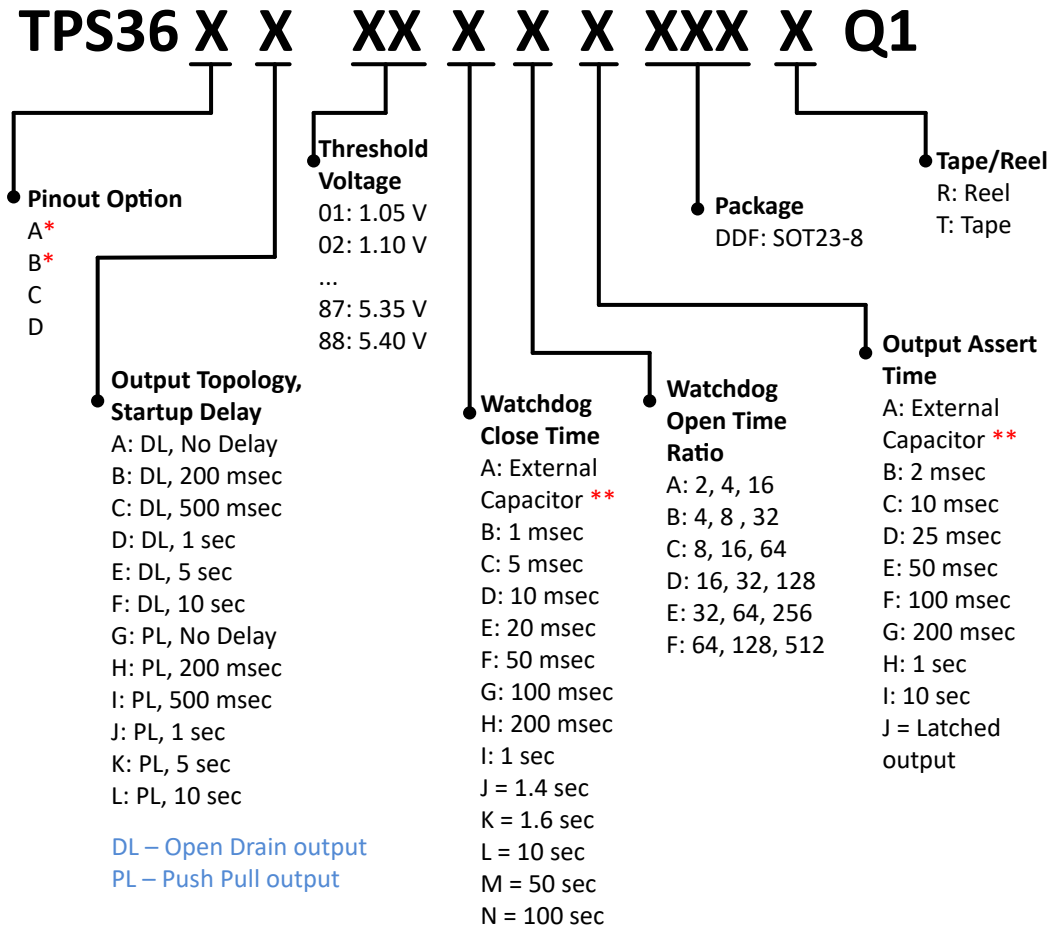

* Pinout option supports Start up Delay settings of “No Delay” and “10 sec” only.
 ** Capacitor programmable time feature available with pinout options A & B. For fixed time and latched output features use pinout options C & D.
 Refer ‘Mechanical, Packaging and Orderable Information’ section for list of released orderable.
 For any other orderable, contact local TI support.

図 5-1. デバイスの命名規則

TPS36-Q1 表 5-1 に示すように、さまざまな機能セットを提供するピン互換デバイス・ファミリに属します。

表 5-1. ピン互換デバイス・ファミリ

デバイス	電圧監視	ウォッチドッグのタイプ
TPS35-Q1	あり	タイムアウト
TPS36-Q1	あり	ウィンドウ
TPS3435-Q1	なし	タイムアウト
TPS3436-Q1	なし	ウィンドウ

6 Pin Configuration and Functions

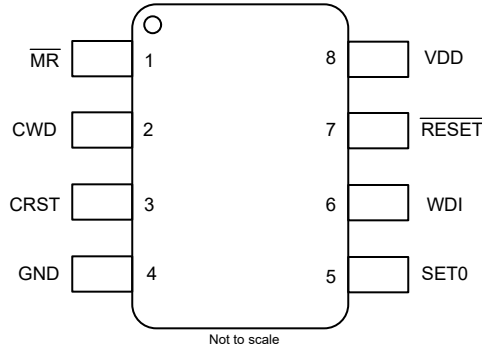

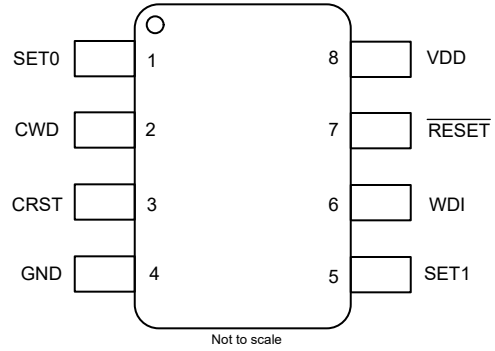

6-1. Pin Configuration Option A
 DDF Package, 8-Pin SOT-23,
 TPS36-Q1 Top View

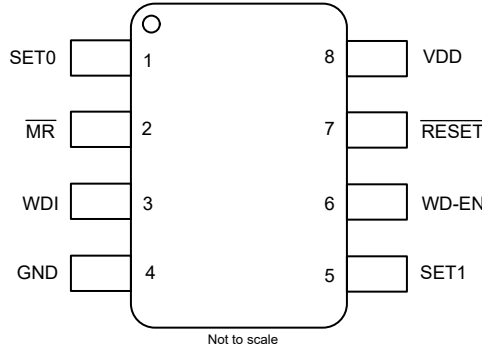

6-2. Pin Configuration Option B
 DDF Package, 8-Pin SOT-23,
 TPS36-Q1 Top View

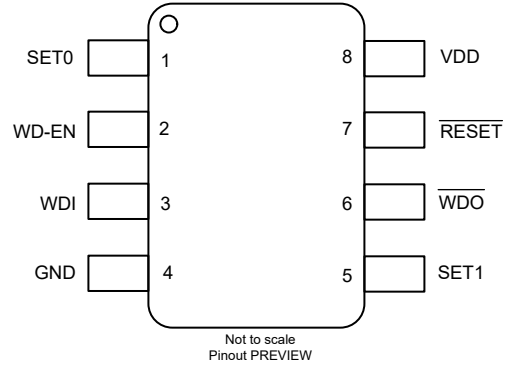

6-3. Pin Configuration Option C
 DDF Package, 8-Pin SOT-23,
 TPS36-Q1 Top View





6-4. Pin Configuration Option D
 DDF Package, 8-Pin SOT-23,
 TPS36-Q1 Top View

表 6-1. Pin Functions

PIN NAME	PIN NUMBER				I/O	DESCRIPTION
	PINOUT A	PINOUT B	PINOUT C	PINOUT D		
CRST	3	3	—	—	I	Programmable reset timeout pin. Connect a capacitor between this pin and GND to program the reset timeout period. See セクション 8.3.4 for more details.
CWD	2	2	—	—	I	Programmable watchdog timeout input. Watchdog close time is set by connecting a capacitor between this pin and ground. See セクション 8.3.2.1 for more details.
GND	4	4	4	4	—	Ground pin
MR	1	—	2	—	I	Manual reset pin. A logic low on this pin asserts the RESET. See セクション 8.3.3 for more details.
RESET	7	7	7	7	O	Reset output. Connect RESET to VDD using a pull up resistance when using open drain output. RESET is asserted when the voltage at the VDD pin goes below the undervoltage threshold (V_{IT}) or MR pin is driven LOW. For pinout options which do not support independent WDO pin, RESET is also asserted for watchdog error. See セクション 8.3.4 for more details.
SET0	5	1	1	1	I	Logic input. SET0, SET1, and WD-EN pins select the watchdog window ratios and enable-disable the watchdog; see セクション 8.3.2.5 for more details.
SET1	—	5	5	5	I	Logic input. SET0, SET1, and WD-EN pins select the watchdog window ratios and enable-disable the watchdog; see セクション 8.3.2.5 for more details.
VDD	8	8	8	8	I	Supply voltage pin. For noisy systems, connecting a 0.1- μ F bypass capacitor is recommended.
WD-EN	—	—	6	2	I	Logic input. Logic high input enables the watchdog monitoring feature. See セクション 8.3.2.3 for more details.
WDI	6	6	3	3	I	Watchdog input. A falling transition (edge) must occur at this pin during the open window in order for RESET / WDO to not assert. See セクション 8.3.2 for more details.
WDO	—	—	—	6	O	Watchdog output. Connect WDO to VDD using pull up resistance when using open drain output. WDO asserts when a watchdog error occurs. WDO only asserts when RESET is high. When a watchdog error occurs, WDO asserts for the set RESET timeout delay (t_D). When RESET is asserted, WDO is deasserted and watchdog functionality is disabled. See セクション 8.3.4 for more details.

7 Specifications

7.1 Absolute Maximum Ratings

over operating free-air temperature range, unless otherwise noted⁽¹⁾

		MIN	MAX	UNIT
Voltage	VDD	-0.3	6.5	V
Voltage	C _{WD} , C _{RST} , WD-EN, SETx, WDI, MR ⁽²⁾ , RESET (Push Pull), WDO (Push Pull)	-0.3	V _{DD} +0.3 ⁽³⁾	V
	RESET (Open Drain), WDO (Open Drain)	-0.3	6.5	
Current	RESET, WDO pin	-20	20	mA
Temperature ⁽⁴⁾	Operating ambient temperature, T _A	-40	125	°C
Temperature	Storage, T _{stg}	-65	150	

- (1) Stresses beyond those listed under *Absolute Maximum Rating* may cause permanent damage to the device. These are stress ratings only, which do not imply functional operation of the device at these or any other conditions beyond those indicated under *Recommended Operating Condition*. Exposure to absolute-maximum-rated conditions for extended periods may affect device reliability.
- (2) If the logic signal driving MR is less than V_{DD}, then additional current flows into V_{DD} and out of MR.
- (3) The absolute maximum rating is (V_{DD} + 0.3) V or 6.5 V, whichever is smaller
- (4) As a result of the low dissipated power in this device, it is assumed that T_J = T_A.

7.2 ESD Ratings

			VALUE	UNIT
V _(ESD)	Electrostatic discharge	Human body model (HBM), per AEC Q100-002 ⁽¹⁾	±2000	V
		Charged device model (CDM), per AEC Q100-011	±750	

- (1) AEC Q100-002 indicates that HBM stressing shall be in accordance with the ANSI/ESDA/JEDEC JS-001 specification.

7.3 Recommended Operating Conditions

over operating free-air temperature range (unless otherwise noted)

		MIN	NOM	MAX	UNIT
Voltage	VDD (Active Low output)	0.9		6	V
	C _{WD} , C _{RST} , WD-EN, SETx, WDI, MR ⁽¹⁾	0		VDD	
	RESET (Open Drain), WDO (Open Drain)	0		6	
	RESET (Open Drain), WDO (Push Pull)	0		VDD	
Current	RESET, WDO pin current	-5		5	mA
C _{RST}	C _{RST} pin capacitor range	1.5		1800	nF
C _{WD}	C _{WD} pin capacitor range	1.5		1000	nF
T _A	Operating ambient temperature	-40		125	°C

- (1) If the logic signal driving MR is less than V_{DD}, then additional current flows into V_{DD} and out of MR. V_{MR} should not be higher than V_{DD}.

7.4 Thermal Information

THERMAL METRIC ⁽¹⁾		TPS36-Q1	UNIT
		DDF (SOT23-8)	
		8 PINS	
$R_{\theta JA}$	Junction-to-ambient thermal resistance	175.3	°C/W
$R_{\theta JC(top)}$	Junction-to-case (top) thermal resistance	94.7	°C/W
$R_{\theta JB}$	Junction-to-board thermal resistance	92.4	°C/W
Ψ_{JT}	Junction-to-top characterization parameter	8.4	°C/W
Ψ_{JB}	Junction-to-board characterization parameter	91.9	°C/W
$R_{\theta JC(bot)}$	Junction-to-case (bottom) thermal resistance	N/A	°C/W

- (1) For more information about traditional and new thermal metrics, see the [Semiconductor and IC Package Thermal Metrics](#) application report.

7.5 Electrical Characteristics

At $1.04\text{ V} \leq V_{DD} \leq 6\text{ V}$, $\overline{\text{MR}} = \text{Open}$, $\overline{\text{RESET}}$ pull-up resistor ($R_{\text{pull-up}}$) = 100 k Ω to VDD, $\overline{\text{WDO}}$ pull-up resistor ($R_{\text{pull-up}}$) = 100 k Ω to VDD, output load (C_{LOAD}) = 10 pF and over operating free-air temperature range -40°C to 125°C , unless otherwise noted. VDD ramp rate $\leq 1\text{ V}/\mu\text{s}$. Typical values are at $T_A = 25^{\circ}\text{C}$

PARAMETER		TEST CONDITIONS		MIN	TYP	MAX	UNIT
COMMON PARAMETERS							
V_{DD}	Input supply voltage	Active LOW output		1.04		6	V
V_{IT-}	Negative-going input threshold accuracy (1)	$V_{IT-} = 1.05\text{ V to }1.95\text{ V}$		-1.4	± 0.5	1.4	%
		$V_{IT-} = 2.0\text{ V to }5.4\text{ V}$		-1.2	± 0.5	1.2	
V_{HYS}	Hysteresis V_{IT-} pin	$V_{IT-} = 1.05\text{ V to }5.4\text{ V}$		3	5	7	%
I_{DD}	Supply current into VDD pin (2)	$V_{DD} = 2\text{ V}$ $V_{IT-} = 1.05\text{ V to }1.95\text{ V}$	$T_A = -40^{\circ}\text{C to }85^{\circ}\text{C}$		0.25	0.8	μA
					0.25	3	
		$V_{DD} = 6\text{ V}$ $V_{IT-} = 1.05\text{ V to }5.4\text{ V}$	$T_A = -40^{\circ}\text{C to }85^{\circ}\text{C}$		0.25	0.8	
					0.25	3	
V_{IL}	Low level input voltage $\overline{\text{WD-EN}}$, $\overline{\text{WDI}}$, $\overline{\text{SETx}}$, $\overline{\text{MR}}$ (3)					$0.3V_{DD}$	V
V_{IH}	High level input voltage $\overline{\text{WD-EN}}$, $\overline{\text{WDI}}$, $\overline{\text{SETx}}$, $\overline{\text{MR}}$ (3)			$0.7V_{DD}$			V
R_{MR}	Manual reset internal pull-up resistance				100		k Ω
RESET / WDO (Open-drain active-low)							
V_{OL}	Low level output voltage	$V_{DD} = 1.5\text{ V}$, $1.55\text{ V} \leq V_{IT-} \leq 3.35\text{ V}$ $I_{\text{OUT(Sink)}} = 500\text{ }\mu\text{A}$				300	mV
		$V_{DD} = 3.3\text{ V}$, $3.4\text{ V} \leq V_{IT-} \leq 5.4\text{ V}$ $I_{\text{OUT(Sink)}} = 2\text{ mA}$				300	
$I_{\text{kg(OD)}}$	Open-Drain output leakage current	$V_{DD} = V_{\text{PULLUP}} = 6\text{ V}$ $T_A = -40^{\circ}\text{C to }85^{\circ}\text{C}$			10	30	nA
		$V_{DD} = V_{\text{PULLUP}} = 6\text{ V}$			10	120	nA
RESET / WDO (Push-pull active-low)							
V_{POR}	Power on $\overline{\text{RESET}}$ voltage (5)	$V_{\text{OL(max)}} = 300\text{ mV}$ $I_{\text{OUT(Sink)}} = 15\text{ }\mu\text{A}$				900	mV
V_{OL}	Low level output voltage	$V_{DD} = 0.9\text{ V}$, $1.05\text{ V} \leq V_{IT-} \leq 1.5\text{ V}$ $I_{\text{OUT(Sink)}} = 15\text{ }\mu\text{A}$				300	mV
		$V_{DD} = 1.5\text{ V}$, $1.55\text{ V} \leq V_{IT-} \leq 3.35\text{ V}$ $I_{\text{OUT(Sink)}} = 500\text{ }\mu\text{A}$				300	
		$V_{DD} = 3.3\text{ V}$, $3.4\text{ V} \leq V_{IT-} \leq 5.4\text{ V}$ $I_{\text{OUT(Sink)}} = 2\text{ mA}$				300	
V_{OH}	High level output voltage	$V_{DD} = 1.8\text{ V}$, $1.05\text{ V} \leq V_{IT-} \leq 1.4\text{ V}$ $I_{\text{OUT(Source)}} = 500\text{ }\mu\text{A}$		$0.8V_{DD}$			V
		$V_{DD} = 3.3\text{ V}$, $1.45\text{ V} \leq V_{IT-} \leq 3.0\text{ V}$ $I_{\text{OUT(Source)}} = 500\text{ }\mu\text{A}$		$0.8V_{DD}$			
		$V_{DD} = 6\text{ V}$, $3.05\text{ V} \leq V_{IT-} \leq 5.4\text{ V}$ $I_{\text{OUT(Source)}} = 2\text{ mA}$		$0.8V_{DD}$			

- (1) V_{IT-} threshold voltage range from 1.05 V to 5.4 V in 50 mV steps.
(2) If the logic signal driving $\overline{\text{MR}}$ is less than V_{DD} , then additional current flows into V_{DD} and out of $\overline{\text{MR}}$.
(3) V_{POR} is the minimum V_{DD} voltage level for a controlled output state

7.6 Timing Requirements

At $1.04\text{ V} \leq V_{DD} \leq 6\text{ V}$, $\overline{\text{MR}}$ = Open, $\overline{\text{RESET}}$ pull-up resistor ($R_{\text{pull-up}}$) = 100 k Ω to VDD, $\overline{\text{WDO}}$ pull-up resistor ($R_{\text{pull-up}}$) = 100 k Ω to VDD, output RESET / WDO load (C_{LOAD}) = 10 pF and over operating free-air temperature range -40°C to 125°C , unless otherwise noted. VDD ramp rate $\leq 1\text{ V}/\mu\text{s}$. Typical values are at $T_A = 25^{\circ}\text{C}$

PARAMETER		TEST CONDITIONS	MIN	TYP	MAX	UNIT
$t_{\text{GL_VIT-}}$	Glitch immunity $V_{\text{IT-}}$	5% $V_{\text{IT-}}$ overdrive ⁽¹⁾		15		μs
$t_{\text{MR_PW}}$	$\overline{\text{MR}}$ pin pulse duration to assert reset			100		ns
$t_{\text{P-WD}}$	WDI pulse duration to start next frame ⁽²⁾	$V_{DD} > V_{\text{IT-}}$	500			ns
$t_{\text{HD-WDEN}}$	WD-EN hold time to enable or disable WD operation ⁽²⁾	$V_{DD} > V_{\text{IT-}}$	200			μs
$t_{\text{HD-SETx}}$	SETx hold time to change WD timer setting ⁽²⁾	$V_{DD} > V_{\text{IT-}}$	150			μs
t_{WC}	Watchdog close window time period	Orderable Option TPS36xxxxB	0.8	1	1.2	ms
		Orderable Option TPS36xxxxC	4	5	6	
		Orderable Option TPS36xxxxD	9	10	11	
		Orderable Option TPS36xxxxE	18	20	22	
		Orderable Option TPS36xxxxF	45	50	55	
		Orderable Option TPS36xxxxG	90	100	110	
		Orderable Option TPS36xxxxH	180	200	220	s
		Orderable Option TPS36xxxxI	0.9	1	1.1	
		Orderable Option TPS36xxxxJ	1.26	1.4	1.54	
		Orderable Option TPS36xxxxK	1.44	1.6	1.76	
		Orderable Option TPS36xxxxL	9	10	11	
		Orderable Option TPS36xxxxM	45	50	55	
		Orderable Option TPS36xxxxN	90	100	110	
t_{WO}	Watchdog open window time period	SETx pin decide multiplier n		$(n-1) \times t_{\text{WC}}$		ms

(1) Overdrive % = $[(V_{DD}/V_{\text{IT-}}) - 1] \times 100\%$

(2) Not production tested

7.7 Switching Characteristics

At $1.04\text{ V} \leq V_{DD} \leq 6\text{ V}$, $\overline{MR} = \text{Open}$, \overline{RESET} pull-up resistor ($R_{\text{pull-up}}$) = 100 k Ω to VDD, \overline{WDO} pull-up resistor ($R_{\text{pull-up}}$) = 100 k Ω to VDD, output RESET / WDO load (C_{LOAD}) = 10 pF and over operating free-air temperature range -40°C to 125°C , unless otherwise noted. VDD ramp rate $\leq 1\text{ V}/\mu\text{s}$. Typical values are at $T_A = 25^{\circ}\text{C}$

PARAMETER		TEST CONDITIONS	MIN	TYP	MAX	UNIT
t_{STRT}	Startup delay ⁽⁴⁾				500	μs
$t_{\text{P_HL}}$	RESET detect delay for VDD falling below $V_{\text{IT-}}$	$V_{DD} : (V_{\text{IT+}} + 10\%) \text{ to } (V_{\text{IT-}} - 10\%)$ (1)		30	50	μs
t_{SD}	Watchdog startup delay	Orderable part number TPS36xA, TPS36xG		0		ms
		Orderable part number TPS36xB, TPS36xH	180	200	220	
		Orderable part number TPS36xC, TPS36xI	450	500	550	
		Orderable part number TPS36xD, TPS36xJ	0.9	1	1.1	s
		Orderable part number TPS36xE, TPS36xK	4.5	5	5.5	
		Orderable part number TPS36xF, TPS36xL	9	10	11	
t_{D}	Reset time delay ⁽³⁾	Orderable part number TPS36xxxxxB	1.6	2	2.4	ms
		Orderable part number TPS36xxxxxC	9	10	11	ms
		Orderable part number TPS36xxxxxD	22.5	25	27.5	ms
		Orderable part number TPS36xxxxxE	45	50	55	ms
		Orderable part number TPS36xxxxxF	90	100	110	ms
		Orderable part number TPS36xxxxxG	180	200	220	ms
		Orderable part number TPS36xxxxxH	0.9	1	1.1	s
		Orderable part number TPS36xxxxxI	9	10	11	s
t_{WDO}	Watchdog timeout delay			t_{D}		s
$t_{\text{MR_RES}}$	Propagation delay from \overline{MR} low to reset assertion	$V_{DD} \geq V_{\text{IT-}} + 0.2\text{ V}$, $\overline{MR} = V_{\text{MR_H}} \text{ to } V_{\text{MR_L}}$		100		ns
$t_{\text{MR_ID}}$	Delay from \overline{MR} release to reset deassert	$V_{DD} = 3.3\text{ V}$, $\overline{MR} = V_{\text{MR_L}} \text{ to } V_{\text{MR_H}}$			t_{D}	s

- (1) $t_{\text{P_HL}}$ measured from threshold trip point ($V_{\text{IT-}}$) to RESET assert. $V_{\text{IT+}} = V_{\text{IT-}} + V_{\text{HYS}}$
- (2) Specified by design parameter. When VDD starts from less than the specified minimum V_{DD} and then exceeds $V_{\text{IT+}}$, reset is deasserted after the startup delay (t_{STRT}) + t_{D} delay.
- (3) VDD voltage transitions from ($V_{\text{IT-}} - 10\%$) to ($V_{\text{IT-}} + 10\%$)

7.8 Timing Diagrams

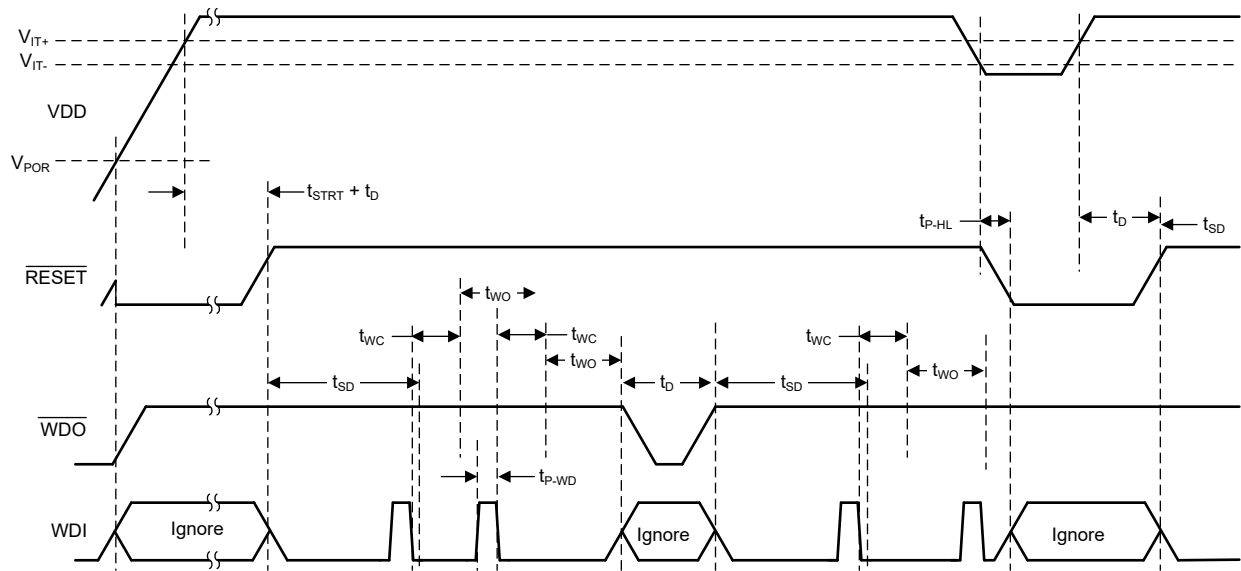

Devices with only RESET output, the output will be AND operation of RESET and WDO signals.

7-1. Functional Timing Diagram

7.9 Typical Characteristics

all curves are taken at $T_A = 25^\circ\text{C}$ (unless otherwise noted)

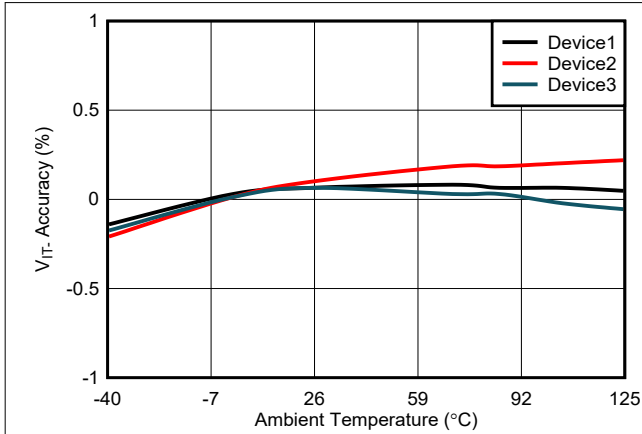

Figure 7-2. V_{IT} Accuracy vs Temperature

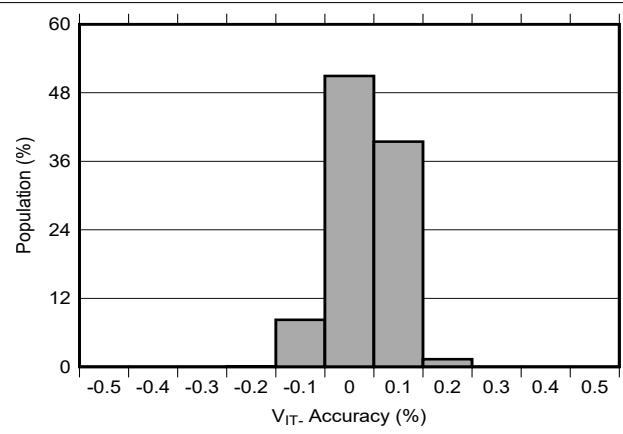

Figure 7-3. V_{IT} Accuracy Histogram

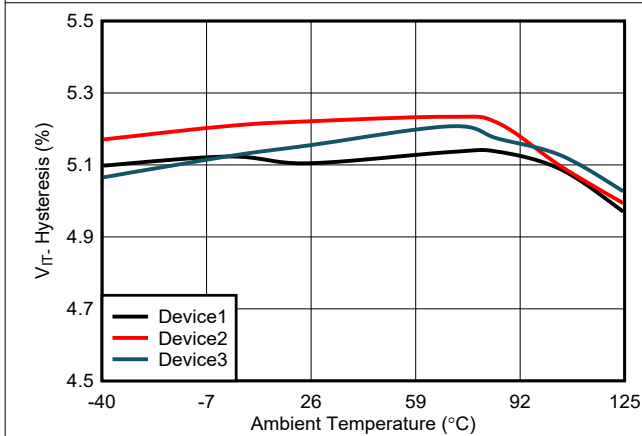

Figure 7-4. V_{IT} Hysteresis Vs Temperature

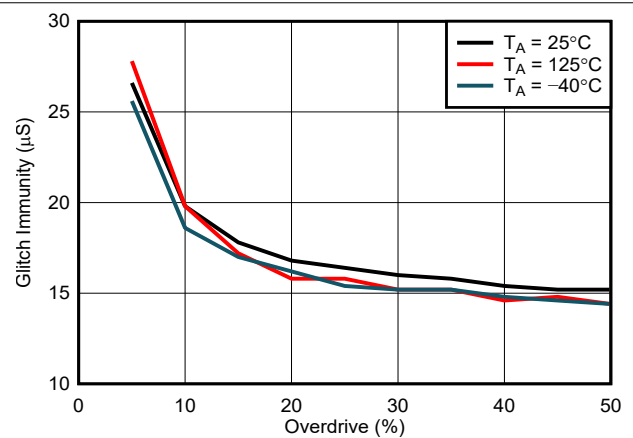

Figure 7-5. Supply Glitch Immunity vs Overdrive

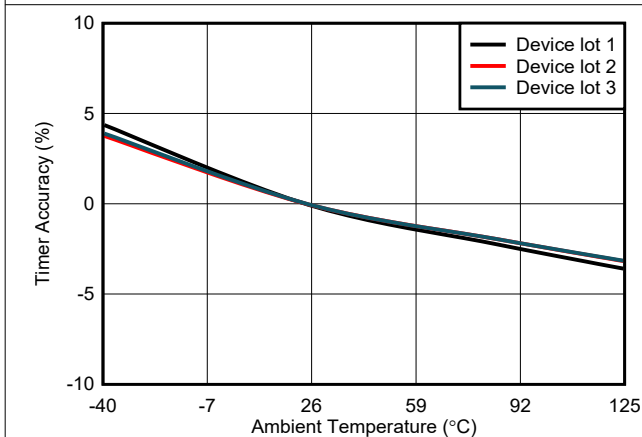

Figure 7-6. Timer Accuracy vs Temperature

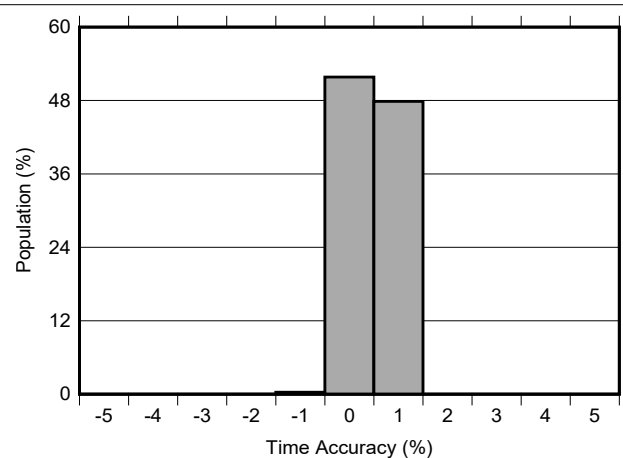
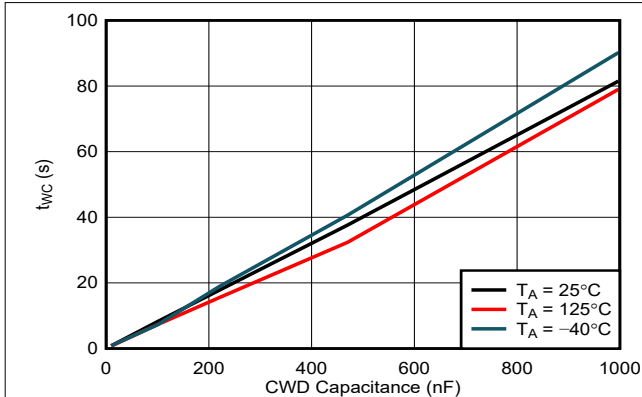

Figure 7-7. Timer Accuracy Histogram

7.9 Typical Characteristics (continued)

all curves are taken at $T_A = 25^\circ\text{C}$ (unless otherwise noted)



7-8. t_{wc} vs Capacitance

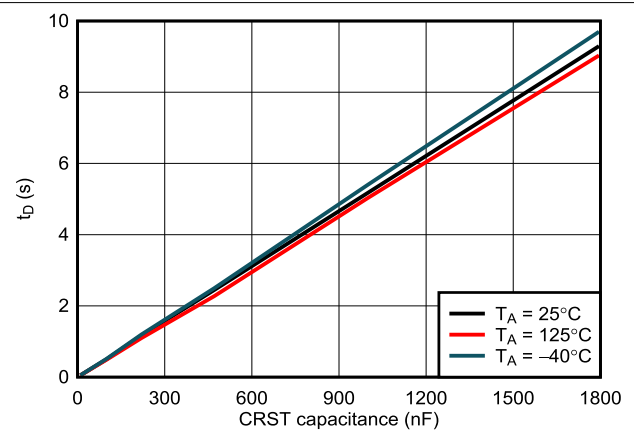

7-9. t_D vs Capacitance

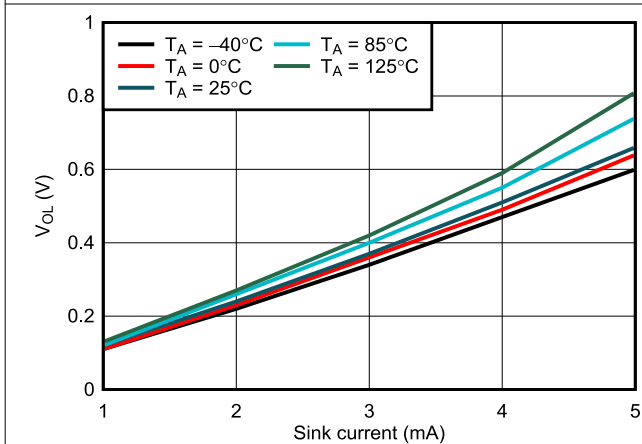

7-10. RESET V_{OL} vs I_{sink} , $V_{DD} = 1.5\text{ V}$

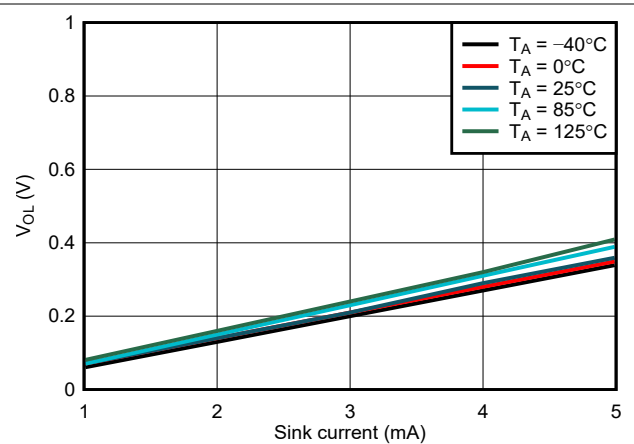

7-11. WDO V_{OL} vs I_{sink} , $V_{DD} = 1.5\text{ V}$

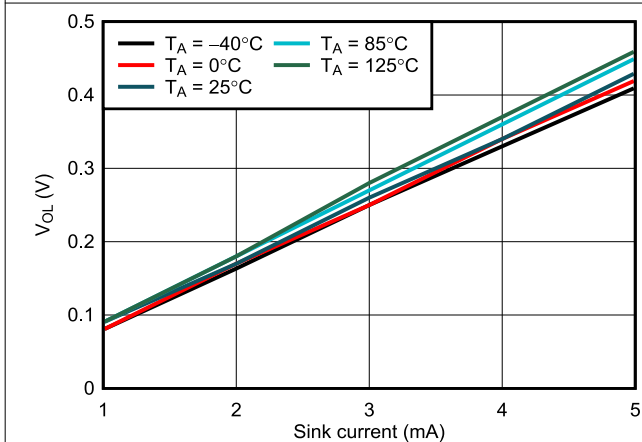

7-12. RESET V_{OL} vs I_{sink} , $V_{DD} = 3.3\text{ V}$

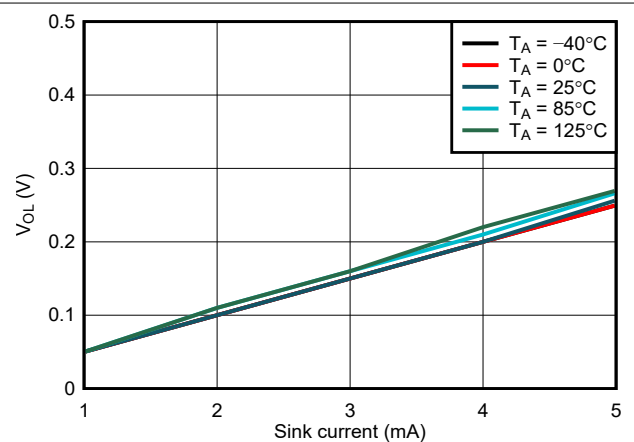

7-13. WDO V_{OL} vs I_{sink} , $V_{DD} = 3.3\text{ V}$

7.9 Typical Characteristics (continued)

all curves are taken at $T_A = 25^\circ\text{C}$ (unless otherwise noted)

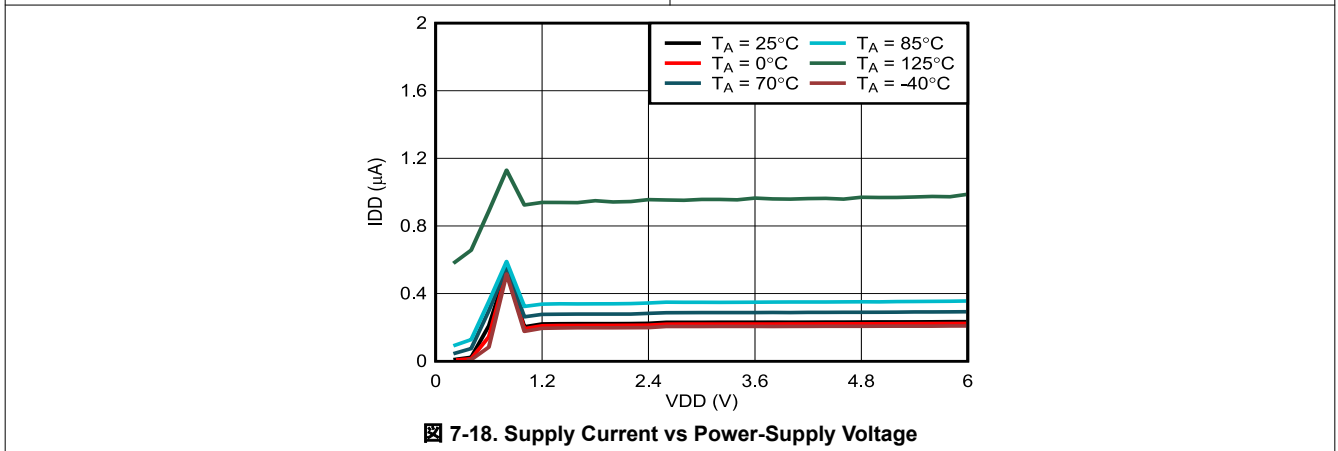
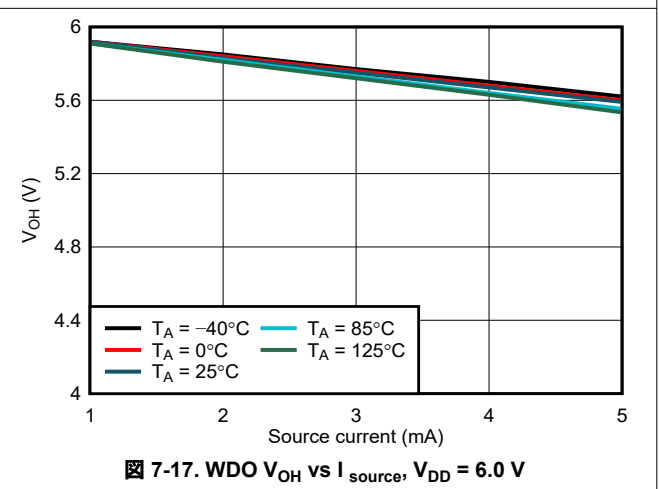
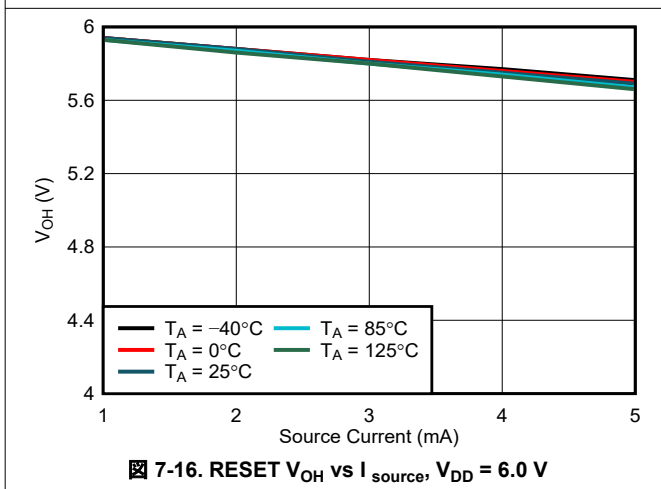
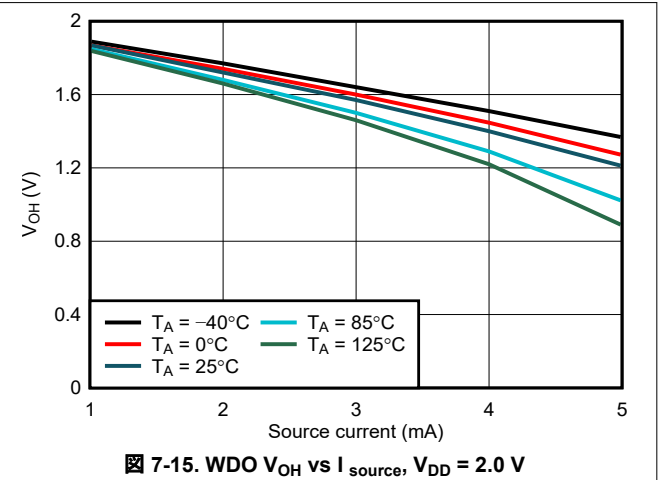
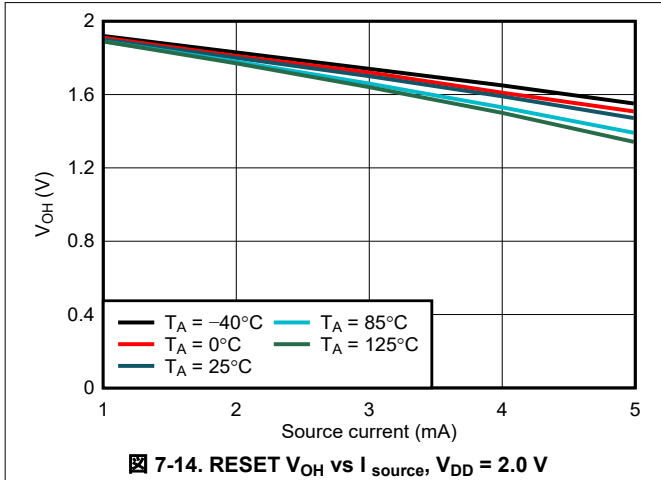

8 Detailed Description

8.1 Overview

The TPS36-Q1 is a high-accuracy under voltage supervisor with an integrated window watchdog timer device. The device family supports multiple features related to watchdog operation in a compact 8 pin SOT23 package. The devices are available in 4 different pinout configurations. Each pinout offers access to different features to meet the various application requirements. The device family is rated for -Q100 applications.

8.2 Functional Block Diagrams

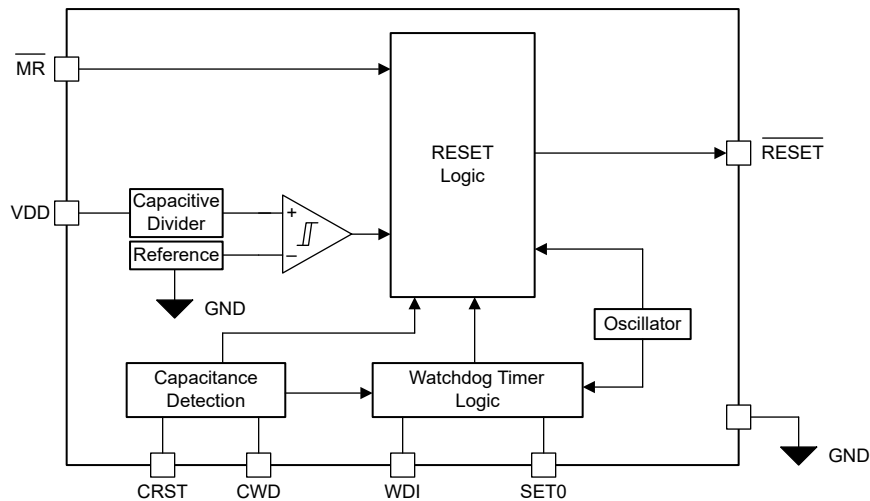

8-1. Pinout Option A

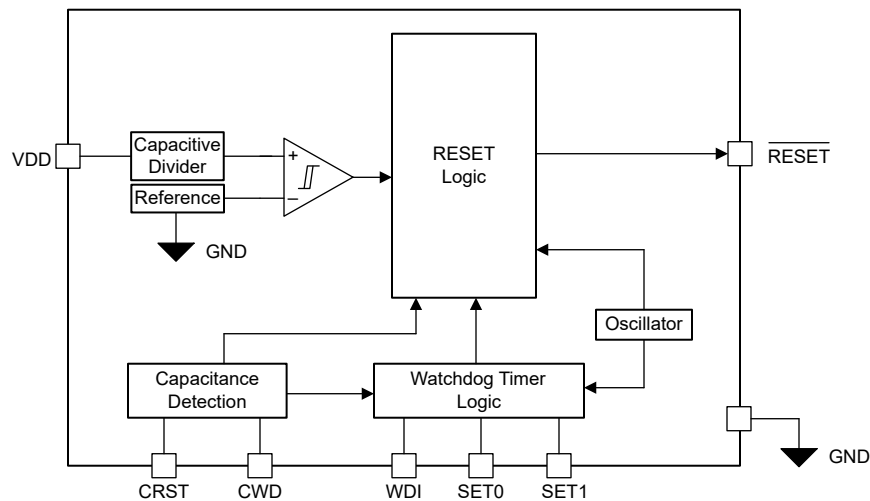

8-2. Pinout Option B

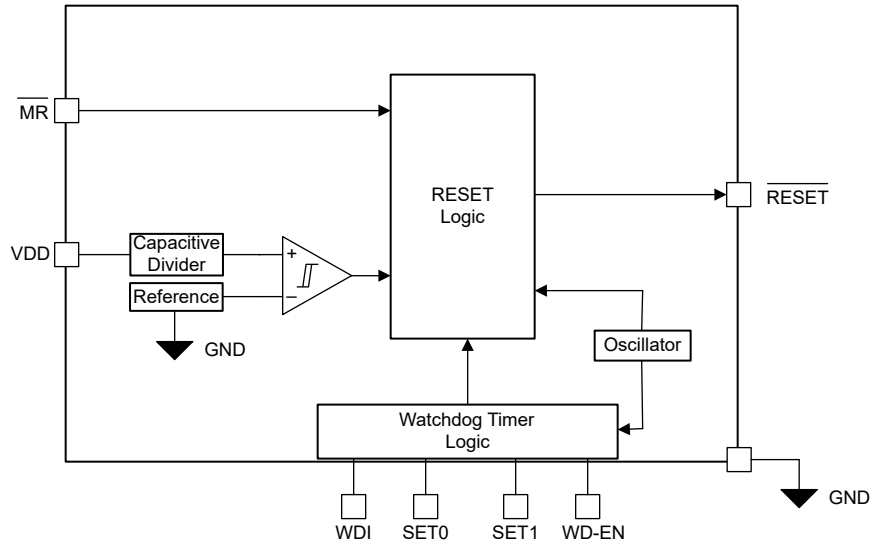

8-3. Pinout Option C

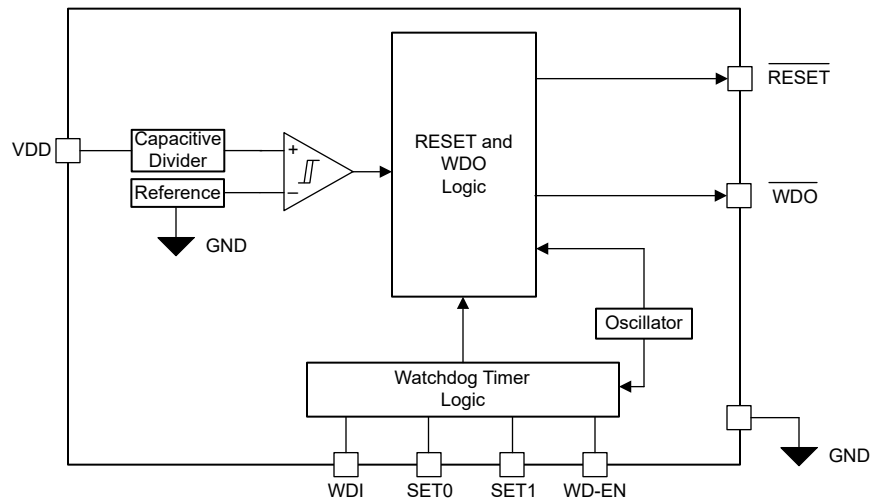

8-4. Pinout Option D

8.3 Feature Description

8.3.1 Voltage Supervisor

The TPS36-Q1 offers high accuracy under voltage supervisor function at very low quiescent current. The voltage supervisor function is always active. After the device powers up from $V_{DD} < V_{POR}$, the RESET and WDO outputs will be actively driven when V_{DD} is greater than V_{POR} . The device starts monitoring the supply level when the V_{DD} voltage is greater than 1.04 V. The device will hold the RESET pin asserted for $t_{STRT} + t_D$ time after the $V_{DD} > V_{IT+}$ ($V_{IT+} = V_{IT-} + V_{HYS}$). Refer [セクション 8.3.4](#) for the t_D value computation. For a capacitor based t_D delay option, the RESET will be asserted for $t_{STRT} + 2$ msec time if the CRST pin is open.

Device pinout options A to C offer only RESET output. In these devices the internal RESET output from supervisor and WDO output from watchdog timer are ANDed together to drive the external RESET output.

The supervisor offers wide range of fixed monitoring thresholds (V_{IT-}) from 1.05 V to 5.40 V in steps of 50 mV. The device asserts the RESET output when the V_{DD} signal falls below V_{IT-} threshold. The device offers hysteresis functionality for voltage supervision. This ensures the supply has recovered above the monitoring threshold before the RESET output is deasserted. The TPS36-Q1 typical voltage hysteresis (V_{HYS}) is 5%. Along with the voltage hysteresis, the device keeps the RESET output asserted for time duration t_D after the supply has

risen above V_{IT+} . The RESET output assert duration changes from t_D to $t_{STRT} + t_D$ if the VDD signal is ramping from voltage $< V_{POR}$. The t_D time duration can be programmable using an external capacitor or fixed time options offered by the device.

The typical timing behavior for a voltage supervisor and the RESET output is showcased in [Figure 8-5](#). The voltage supervisor monitoring output has higher priority over watchdog functionality. If the device voltage supervisor output is asserted, the watchdog functionality will be disabled including WDO assert control. The device resumes watchdog related functionality only after the supply is stable and the t_D time duration has elapsed.

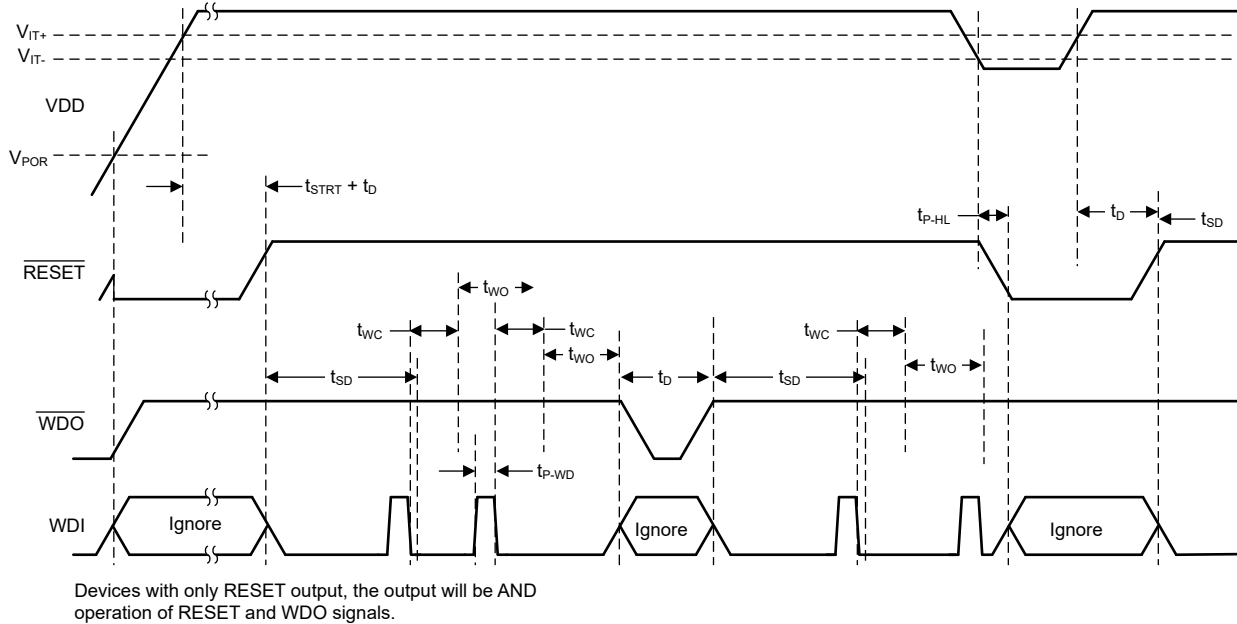

Figure 8-5. Voltage Supervisor Timing Diagram

8.3.2 Window Watchdog Timer

The TPS36-Q1 offers high precision window watchdog timer monitoring. The device is available in multiple pinout options A to D which support multiple features to meet ever expanding needs of various applications. Ensure a correct pinout is selected to meet the application needs.

The window watchdog is active when the VDD voltage is higher than the $V_{IT-} + V_{HYS}$ and the RESET is deasserted after the t_D time. The watchdog stays active as long as $VDD > V_{IT-}$ and watchdog is enabled. TPS36-Q1 family offers various startup time delay options to ensure enough time is available for the host to complete boot operation. Please refer [Section 8.3.2.4](#) for additional details.

The window watchdog timer frame consists of two windows namely close window (t_{WC}) followed by open window (t_{WO}). The device monitors the WDI pin for falling edge. User is expected to provide a valid falling edge on WDI pin in the open window. Refer [Section 5](#) to arrive at the relevant close window and open window values needed for application. The timer value is reset when a valid falling edge is detected on WDI pin in the t_{WO} time duration. An early fault is reported if a WDI falling edge is detected in close window. A late fault is reported if WDI falling edge is not detected in both close and open window. The device asserts RESET output for pinout options A, B and C or WDO output for pinout D for time t_D in event of watchdog fault. Refer [Section 8.3.4](#) to arrive at the relevant t_D value needed for application.

[Figure 8-6](#) shows the basic operation for window watchdog timer operation. The TPS36-Q1 watchdog functionality supports multiple features. Details are available in following sub sections.



图 8-6. Window Watchdog Timer Operation

8.3.2.1 t_{WC} (Close Window) Timer

The window watchdog frame consists of two sub frames t_{WC} followed by t_{WO} . The host is not expected to drive valid WDI transition during t_{WC} time. A valid WDI transition during t_{WC} frame results in early fault condition and the WDO output is asserted. RESET output is asserted if pinout does not offer independent WDO output. The t_{WC} timer for TPS36-Q1 can be set using an external capacitor connected between CWD pin and GND pin. This feature is available with pinout options A or B. Applications which are space constrained or need timer values which meet offered timer options, can benefit when using pinout options C or D. The TPS36-Q1 offers multiple fixed timer options ranging from 1 msec up-to 100 sec.

The TPS36-Q1 when using capacitance based timer, senses the capacitance value during the power up or after a RESET event. The capacitor is charged and discharged with known internal current source for one cycle to sense the capacitance value. The sensed value is used to arrive at t_{WC} timer for the watchdog operation. This unique implementation helps reduce the continuous charge and discharge current for the capacitor, thus reducing overall current consumption. Continuous charge and discharge of capacitance creates wider dead time (no watchdog monitor functionality) when capacitor is discharging. The dead time is higher for high value of capacitance. The unique implementation of TPS36-Q1 helps avoid the dead time as the capacitance is not continuously charging or discharging under normal operation. Ensure C_{CWD} is $< 200 \times C_{CRST}$ for accurate calibration of capacitance. The close time window is decided based on SETx pin combination and the CWD capacitance. 表 8-1 to 表 8-3 highlights the relationship between t_{WC} in second and CWD capacitance in farad. The t_{WC} timer is 20% accurate for an ideal capacitor. Accuracy of the capacitance will have additional impact on the t_{WC} time. Ensure the capacitance meets the recommended operating range. Capacitance outside the recommended range can lead to incorrect operation of the device.

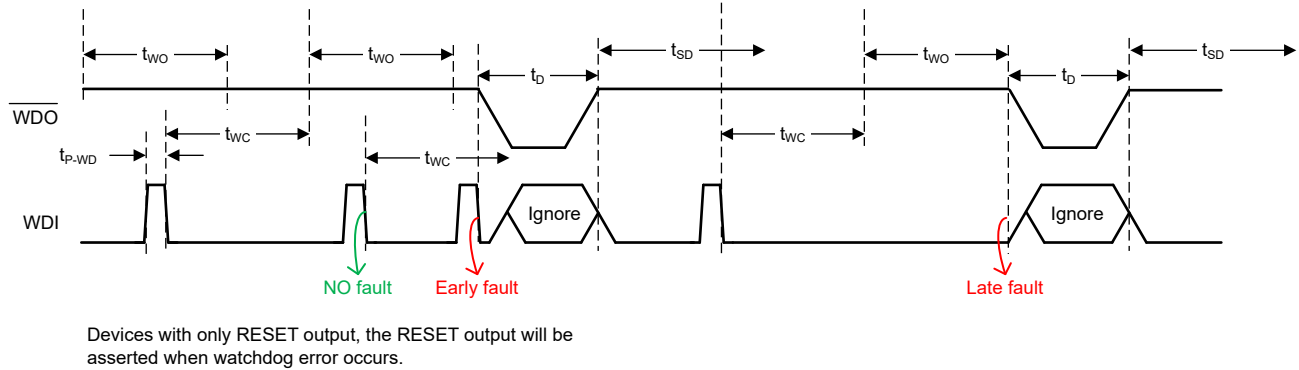
表 8-1. t_{WC} Equation 1 SET Pin (Pin Configuration A)

SET pin value	Equation
0	$t_{WC} \text{ (sec)} = 79.2 \times 10^6 \times C_{CWD} \text{ (F)}$
1	$t_{WC} \text{ (sec)} = 39.6 \times 10^6 \times C_{CWD} \text{ (F)}$

表 8-2. t_{WC} Equation 2 SET Pin, WD-EN = 1 (Pin Configuration C, D)

SET Pin Value	Equation
00	$t_{WC} \text{ (sec)} = 79.2 \times 10^6 \times C_{CWD} \text{ (F)}$
01	$t_{WC} \text{ (sec)} = 79.2 \times 10^6 \times C_{CWD} \text{ (F)}$
10	$t_{WC} \text{ (sec)} = 39.6 \times 10^6 \times C_{CWD} \text{ (F)}$
11	$t_{WC} \text{ (sec)} = 9.9 \times 10^6 \times C_{CWD} \text{ (F)}$

表 8-3. t_{WC} Equation 2 SET Pin, WD-EN Not Available (Pin Configuration B)

SET Pin Value	Equation
00	$t_{WC} \text{ (sec)} = 79.2 \times 10^6 \times C_{CWD} \text{ (F)}$
01	Watchdog disabled
10	$t_{WC} \text{ (sec)} = 39.6 \times 10^6 \times C_{CWD} \text{ (F)}$
11	$t_{WC} \text{ (sec)} = 9.9 \times 10^6 \times C_{CWD} \text{ (F)}$

The TPS36-Q1 also offers wide selection of high accuracy fixed t_{WC} timer options starting from 1 msec to 100 sec including various industry standard values. The TPS36-Q1 fixed time options are $\pm 10\%$ accurate for $t_{WC} \geq 10$ msec. For $t_{WC} < 10$ msec, the accuracy is $\pm 20\%$. t_{WC} value relevant to application can be identified from the orderable part number. Refer [セクション 5](#) to identify mapping of orderable part number to t_{WC} value.

8.3.2.2 t_{WO} (Open Window) Timer

The window watchdog frame consists of two sub frames t_{WC} followed by t_{WO} . The host is expected to drive valid WDI transition during t_{WO} time. A valid WDI transition before beginning of t_{WO} frame causes early fault condition. Failure to offer valid WDI transition during t_{WC} and t_{WO} frames results in late fault condition. When a fault condition is detected the WDO output is asserted. RESET output is asserted if pinout does not offer independent WDO output.

The t_{WO} value is derived using t_{WC} value and the window open time ratio value n . [Equation](#) highlights the relationship between t_{WO} and t_{WC} . Refer [セクション 5](#) to select available ratio options.

$$t_{WO} = (n - 1) \times t_{WC} \quad (1)$$

Each orderable can offer up to 3 ratio options based on the available SET pins. Refer [セクション 8.3.2.5](#) to identify mapping of ratio value to SET pin control. The maximum t_{WO} value is limited to 640 second. Ensure selected t_{WC} and ratio combination does not lead to t_{WO} value greater than 640 second.

8.3.2.3 Watchdog Enable Disable Operation

The TPS36-Q1 supports watchdog enable or disable functionality. This functionality is critical for different use cases as listed below.

- Disable watchdog during firmware update to avoid host RESET.
- Disable watchdog during software step-by-step debug operation.
- Disable watchdog when performing critical task to avoid watchdog error interrupt.
- Keep watchdog disabled until host boots up.

The TPS36-Q1 supports watchdog enable or disable functionality through either WD-EN pin (pin configuration C,D) or SET[1:0] = 0b'01 (pin configuration B) logic combination. For a given pinout only one of these two methods is available for the user to disable watchdog operation.

For a pinout which offers a WD-EN pin, the watchdog enable disable functionality is controlled by the logic state of WD-EN pin. Drive WD-EN = 1 to enable the watchdog operation or drive WD-EN = 0 to disable the watchdog operation. The WD-EN pin can be toggled any time during the device operation. The [図 8-7](#) diagram shows timing behavior with WD-EN pin control.



図 8-7. Watchdog Enable: WD-EN Pin Control

SET[1:0] = 0b'01 combination can be used to disable watchdog operation with a pinout which offers SET1 and SET0 pins, but does not include WD-EN pin. The SET pin logic states can be changed at any time during watchdog operation. Refer [セクション 8.3.2.5](#) section for additional details regarding SET[1:0] pin behavior.

Pinout options A, B offer watchdog timer control using a capacitance connected between CWD and GND pin. A capacitance value higher than recommended or connect to GND leads to watchdog functionality getting disabled. Capacitance based disable operation overrides the other two options mentioned above. Changing capacitance on the fly does not enable or disable watchdog operation. A power supply recycle or device recovery after UV fault, \overline{MR} low event is needed to detect change in capacitance.

Ongoing watchdog frame is terminated when watchdog is disabled. WDO stays deasserted when watchdog operation is disabled. For a pinout with only RESET output, the RESET can assert if supply supervisor error occurs. When enabled the device immediately enters t_{WC} frame and start watchdog monitoring operation.

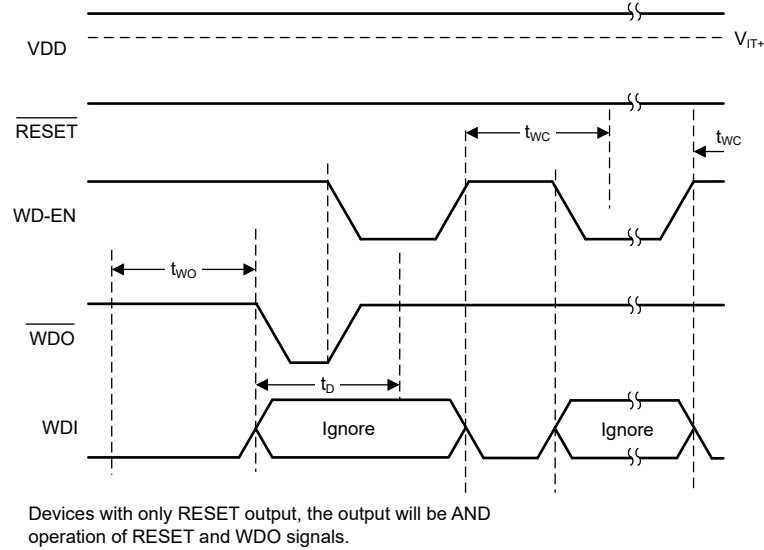
8.3.2.4 t_{SD} Watchdog Start Up Delay

The TPS36-Q1 supports watchdog startup delay feature. This feature is activated after power up or after a RESET assert event or after WDO assert event. When t_{SD} frame is active, the device monitors the WDI pin but the WDO output is not asserted. This feature allows time for the host complete boot process before watchdog monitoring can take over. The start up delay helps avoid unexpected WDO or RESET assert events during boot. The t_{SD} time is predetermined based on the device part number selected. Refer [セクション 5](#) section for details to map the part number to t_{SD} time. Pinout option A, B are available only in no delay or 10 sec start up delay options.

The t_{SD} frame is complete when the time duration selected for t_{SD} is over or host provides a valid transition on the WDI pin. The host must provide a valid transition on the WDI pin during t_{SD} time. The device exits the t_{SD} frame and enters watchdog monitoring phase after valid WDI transition. Failure to provide valid transition on WDI pin triggers the watchdog error by asserting the WDO output pin. For devices with only RESET output, the RESET pin is asserted.

The t_{SD} frame is not initiated when the watchdog functionality is enabled using WD-EN pin or SET[1:0] pin or WDI float functionality as described in [セクション 8.3.2.3](#) section.

図 8-8 shows the operation for t_{SD} time frame.

表 8-4. t_{WO} Values with SET0 Pin Only (Pin Configuration A)

Watchdog Open Time Ratio Selection	t_{WO}	
	SET0 = 0	SET0 = 1
A	10 msec	30 msec
B	30 msec	70 msec
C	70 msec	150 msec
D	150 msec	310 msec
E	310 msec	630 msec
F	630 msec	1270 msec

Pinout which offer both SET0 & SET1 pins to the user, the t_{WO} ratio value is decided based on the Watchdog Open Time Ratio selector field in the orderable part number. Refer [セクション 5](#) for available options. Two SETx pins offer 3 different time scaling options. The SET[1:0] = 0b'01 combination disables the watchdog operation. [表 8-5](#) showcases an example of the t_{WO} values for different SET[1:0] logic levels when using Watchdog Close Time setting as option G = 100 msec. The package pin out selected does not offer WD-EN pin.

表 8-5. t_{WO} Values with SET0 & SET1 Pins, WD-EN Pin Not Available (Pin Configuration B)

Watchdog Open Time Ratio selection	t_{WO}			
	SET[1:0] = 0b'00	SET[1:0] = 0b'01	SET[1:0] = 0b'10	SET[1:0] = 0b'11
A	100 msec	Watchdog disable	300 msec	1500 msec
B	300 msec	Watchdog disable	700 msec	3100 msec
C	700 msec	Watchdog disable	1500 msec	6300 msec
D	1500 msec	Watchdog disable	3100 msec	12700 msec
E	3100 msec	Watchdog disable	6300 msec	25500 msec
F	6300 msec	Watchdog disable	12700 msec	51100 msec

1. Example for Watchdog Close Time setting = 100 msec.

Selected pinout option can offer WD-EN pin along with SET[1:0] pins (Pin Configuration C, D). With this pinout, the WD-EN pin controls watchdog enable and disable operation. The SET[1:0] = 0b'01 combination operates as SET[1:0] = 0b'00.

Ensure the t_{WO} value with SETx ratio does not exceed 640 sec. If a selection of close window timer and ratio results in $t_{WO} > 640$ sec, the timer value will be restricted to 640 sec.

[図 8-9](#) to [図 8-11](#) show the timing behavior with respect to SETx status changes.



図 8-9. Watchdog Behavior with SETx Pin Status

SET Pin (2 Pins) Operation; WD_EN Pin Not Available



SET Pin (2 Pins) Operation; WD_EN Available = 1

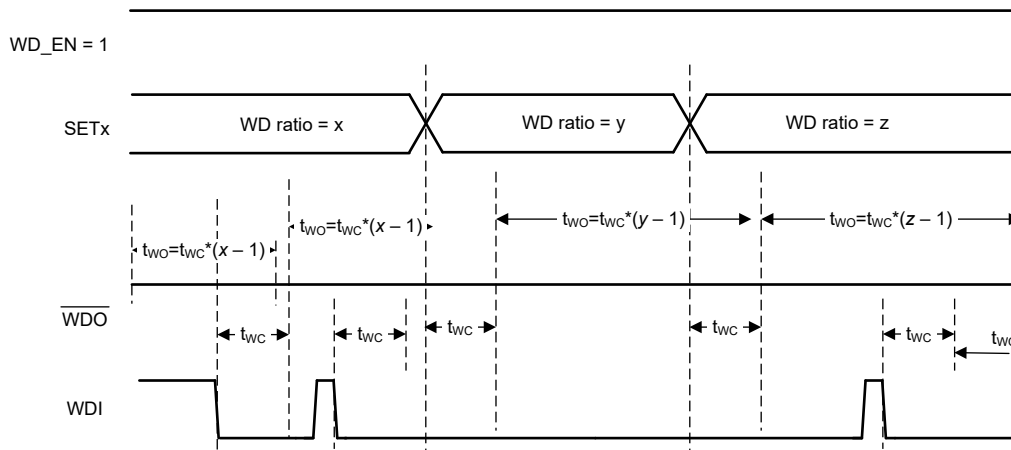
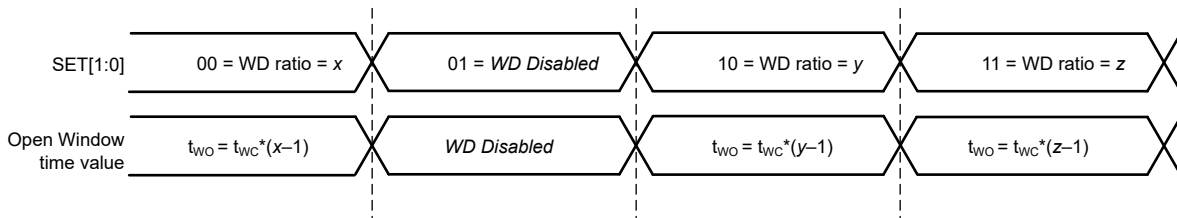
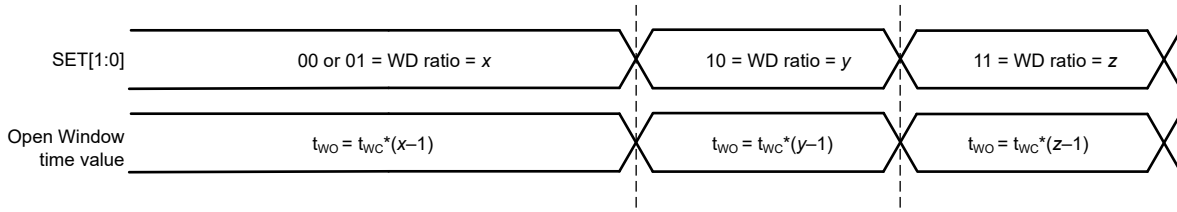

t_{WC} = Fixed based on OPN or programmable using capacitor
x, y, z = Fixed based on ratio chosen

8-10. Watchdog Operation with 2 SET Pins

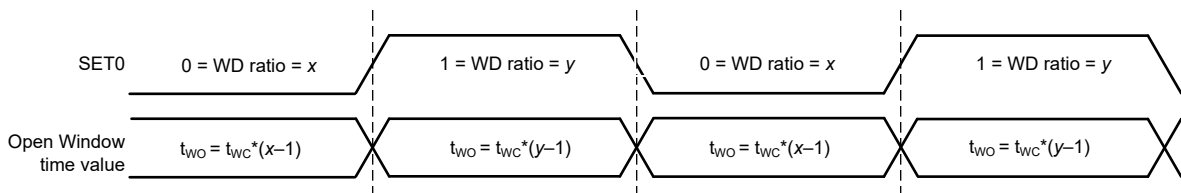

t_{WC} = Fixed based on OPN or programmable using capacitor
X, y = Fixed based on ratio chosen

8-11. Watchdog Operation with 1 SET Pin

8.3.3 Manual RESET

The TPS36-Q1 supports manual reset functionality using \overline{MR} pin. \overline{MR} pin when driven with voltage lower than $0.3 \times V_{DD}$, asserts the RESET output. The \overline{MR} pin has $100 \text{ k}\Omega$ pull up to V_{DD} . The \overline{MR} pin can be left floating. The internal pull up will ensure the output is not asserted due to \overline{MR} pin trigger.

The output is deasserted after \overline{MR} pin voltage rises above $0.7 \times V_{DD}$ voltage and time t_D is elapsed. Refer 8-12 for more details.

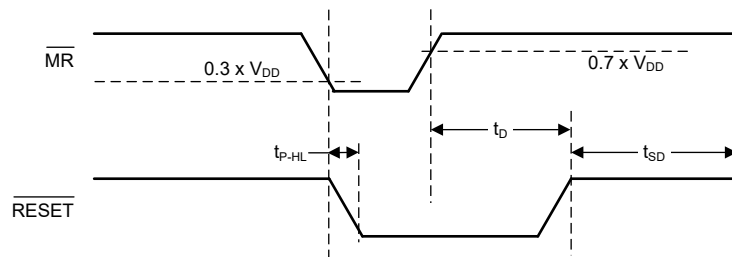

8-12. \overline{MR} Pin Response

8.3.4 RESET and WDO Output

The TPS36-Q1 device can offer RESET or RESET with independent WDO output pin. The output configuration is dependent on the pinout variant selected. For a pinout which has only RESET output, the RESET output is asserted when VDD voltage is below the monitored threshold or \overline{MR} pin voltage is lower than threshold or watchdog timer error is detected. For a pinout which has independent RESET and WDO output pins, the RESET output is asserted when VDD voltage is below the monitored threshold or \overline{MR} pin voltage is lower than threshold. WDO output is asserted only when watchdog timer error is detected. RESET error has higher priority than WDO error. If RESET is asserted when WDO is asserted, the device deasserts the WDO pin and watchdog is disabled until RESET pin is deasserted and startup delay frame is terminated.

The output will be asserted for t_D time when any relevant events described above are detected. The time t_D can be programmed by connecting a capacitor between CRST pin and GND or device will assert t_D for fixed time duration as selected by orderable part number. Refer [セクション 5](#) section for all available options.

[式 2](#) describes the relationship between capacitor value and the time t_D . Ensure the capacitance meets the recommended operating range. Capacitance outside the recommended range can lead to incorrect operation of the device.

$$t_D (\text{sec}) = 4.95 \times 10^6 \times C_{\text{CRST}} (\text{F}) \quad (2)$$

TPS36-Q1 also offers a unique option of latched output. An orderable with latched output will hold the output in asserted state indefinitely until the device is power cycled or the error condition is addressed. If the output is latched due to voltage supervisor undervoltage detection, the output latch will be released when VDD voltage rises above the $V_{IT+} + V_{HYS}$ level. If the output is latched due to \overline{MR} pin low voltage, the output latch will be released when \overline{MR} pin voltage rises above $0.7 \times V_{DD}$ level. If the output is latched due to watchdog timer error, the output latch will be released when a WDI negative edge is detected or the device is shutdown and powered up again. [図 8-13](#) shows timing behavior of the device with latched output configuration.



图 8-13. Output Latch Timing Behavior

8.4 Device Functional Modes

表 8-6 summarizes the functional modes of the TPS36-Q1.

表 8-6. Device Functional Modes

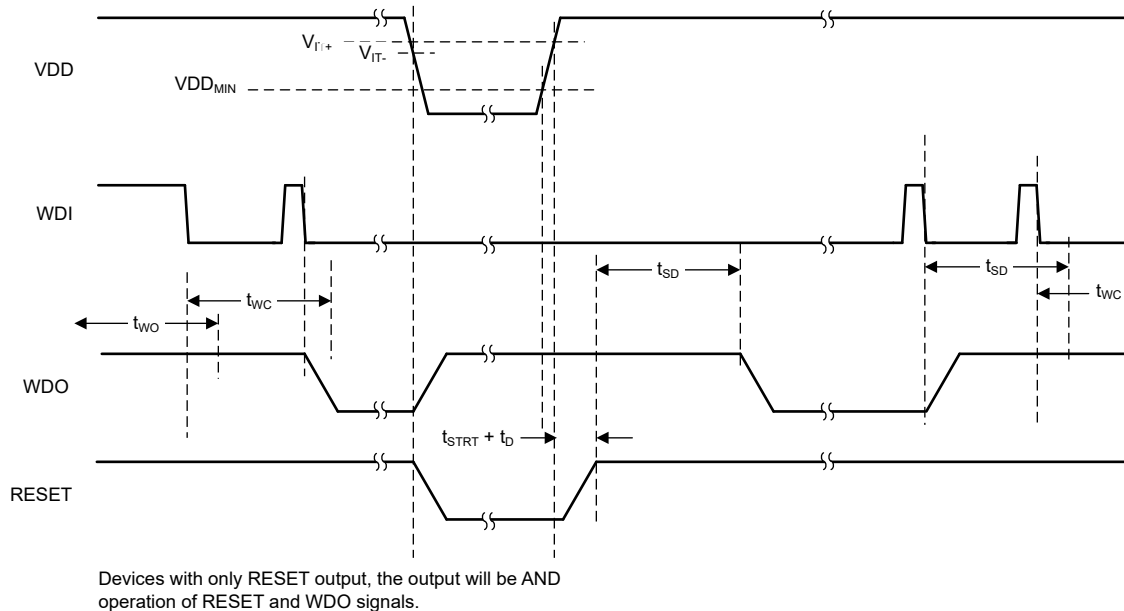
VDD	WATCHDOG STATUS	WDI	WDO	RESET
$V_{DD} < V_{POR}$	Not Applicable	—	Undefined	Undefined
$V_{POR} \leq V_{DD} < V_{IT-}$	Not Applicable	Ignored	High	Low
$V_{DD} \geq V_{IT+}$	Disabled	Ignored	High	High
	Enabled	$t_{WC(max)} \leq t_{pulse}^1 \leq t_{WC(max)} + t_{WO(min)}$	High	High
	Enabled	$t_{WC(max)} > t_{pulse}^1$	Low	High
	Enabled	$t_{WC(max)} + t_{WO(max)} < t_{pulse}^1$	Low	High

(1) Where t_{pulse} is the time between falling edges on WDI.

9 Application and Implementation

注

Information in the following applications sections is not part of the TI component specification, and TI does not warrant its accuracy or completeness. TI's customers are responsible for determining suitability of components for their purposes, as well as validating and testing their design implementation to confirm system functionality.

9.1 Application Information

The following sections describe in detail proper device implementation, depending on the final application requirements.

9.1.1 CRST Delay

The TPS36-Q1 features two options for setting the reset delay (t_D): using a fixed timing and programming the timing through an external capacitor.

9.1.1.1 Factory-Programmed Reset Delay Timing

Fixed reset delay timings are available using pinouts C and D. Using these timings enables a high-precision, 10% accurate reset delay timing.

9.1.1.2 Adjustable Capacitor Timing

The TPS36-Q1 also offers programmable reset delay option when using pinout A and B. The TPS36-Q1 can be programmed to have a desired reset delay by connecting a capacitor between CRST pin and GND. The typical delay time resulting from a given external capacitance on the CRST pin can be calculated by 式 3, where t_D is the reset delay time in seconds and C_{CRST} is the capacitance in farads.

$$t_D (\text{sec}) = 4.95 \times 10^6 \times C_{CRST} (\text{F}) \quad (3)$$

To minimize the difference between the calculated reset delay time and the actual reset delay time, use a high-quality ceramic dielectric COG capacitor and minimize parasitic board capacitance around this pin. 表 9-1 lists the reset delay time ideal capacitor values for C_{CRST} .

表 9-1. Reset Delay Time for Common Ideal Capacitor Values

C_{CRST}	RESET DELAY TIME (t_D)			UNIT
	MIN ⁽¹⁾	TYP	MAX ⁽¹⁾	
10 nF	39.6	49.5	59.4	ms
100 nF	396	495	594	ms
1 μ F	3960	4950	5940	ms

(1) Minimum and maximum values are calculated using ideal capacitors.

9.1.2 Watchdog Window Functionality

The TPS36-Q1 features two options for setting the close window watchdog timer (t_{WC}): using a fixed timing and programming the timing through an external capacitor.

9.1.2.1 Factory-Programmed watchdog Timing

Fixed watchdog window close timings are available using pinout C and D. Using these timings enables a high-precision, 10% accurate watchdog timer t_{WC} .

9.1.2.2 Adjustable Capacitor Timing

Pinout options A and B support adjustable t_{WC} timing. This is achievable by connecting a capacitor between CWD and GND pin. Consult 表 8-1, 表 8-2, and 表 8-3 for calculating typical t_{WC} values using ideal capacitors. Capacitor tolerances will cause additional deviation. For the most accurate timing, use ceramic capacitors with COG dielectric material.

9.2 Typical Applications

9.2.1 Design 1: Monitoring Microcontroller Supply and Watchdog During Operational and Sleep Modes

The TPS36-Q1 can utilize high-accuracy voltage monitoring and on-the-fly SETx assigning to monitor a microcontroller that has both an operational and sleep mode.

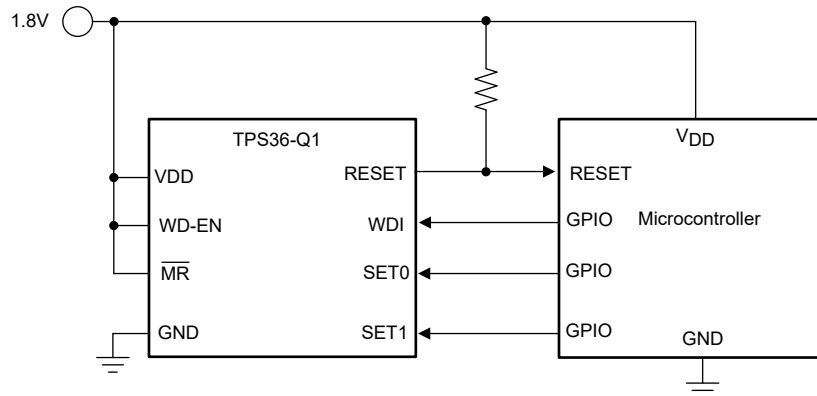

Copyright © 2023, Texas Instruments Incorporated

☒ 9-1. Monitoring Microcontroller Supply and Watchdog During Operation and Sleep

9.2.1.1 Design Requirements

表 9-2. Design Parameters

PARAMETER	DESIGN REQUIREMENT	DESIGN RESULT
Voltage Threshold	Typical Voltage Threshold of 1.65 V	Typical Voltage Threshold of 1.65 V
Window Close Time During Operation	Typical t_{WC} of 50 ms during operation	Typical t_{WC} of 50 ms
Window Open Time During Operation	Typical t_{WO} of 1.4 s during operation	Typical t_{WO} of 1.55 s
Window Close Time During Sleep	Typical t_{WC} of 50 ms during sleep	Typical t_{WC} of 50 ms
Window Open Time During Sleep	Typical t_{WO} of 12 s during operation	Typical t_{WO} of 12.75 s
RESET Delay	200 ms	200 ms
Output Logic	Open-drain	Open-drain
Maximum Device Current Consumption	20 μ A	250 nA typical, 3 μ A maximum

9.2.1.2 Detailed Design Procedure

9.2.1.2.1 Setting Voltage Threshold

The negative-going threshold voltage, V_{IT-} , is set by the device variant. 式 4 shows how to calculate the "Threshold Voltage" section of the orderable part number.

$$\text{OPN "Threshold Voltage" number} = (V_{IT-} - 1) / 0.05 \quad (4)$$

In this example, the nominal supply voltage for the microcontroller is 1.8 V. The minimum supply voltage is 10% lower than the nominal supply voltage, or 1.62 V. Setting a 1.65 V threshold ensures that the device is reset just before the supply voltage reaches the minimum allowed. Thus a 1.65 V threshold is chosen and, using 式 4, the part number is reduced to TPS36xx13xxxxxxQ1. The hysteresis is 5% typical, resulting in a positive-going threshold voltage, V_{IT+} , of 1.73 V.

9.2.1.2.2 Determining Window Timings During Operation and Sleep Modes

The TPS36-Q1 allows for precise 10% accurate watchdog timings. This application requires two different window timings in order to maximize power efficiency: one for the microcontroller's operational state and one for its sleep state. To achieve this, the host can reassign the SETx pins when it transitions between states. A window close time, t_{WC} , of 50 ms typical is chosen because of the application's 50 ms typical t_{WC} requirement. The application requires a minimum watchdog open time, t_{WO} , of 1.4 s during operation and a t_{WO} of 12 s during sleep. Thus, the possible variant options are narrowed to TPS36xx13FExDDFRQ1.

9.2.1.2.3 Meeting the Minimum Reset Delay

The TPS36-Q1 features two options for selecting reset delays: fixed delays and capacitor-programmable delays. The TPS36-Q1 supports only fixed watchdog timings and fixed reset delays or programmable watchdog timings and programmable reset delays. The application requires a 200 ms minimum reset delay, thus reset delay option G is used. Because of these requirements and no need for a startup delay, the TPS36CA13FEGDDFRQ1 is used.

9.2.1.2.4 Setting the Watchdog Window

In this application, the watchdog timing options are based on the WDI signal that is provided to the TPS36-Q1. A watchdog WDI setting must be chosen such that a transition must always occur within the open watchdog window. There are several ways to achieve these window parameters. An external capacitor can be placed on the CWD pin and calculated to have a sufficient window close time. Another option is to use one of the factory-programmed timing options. An additional advantage of choosing one of the factory-programmed options is the ability to reduce the number of components required, thus reducing overall BOM cost.

9.2.1.2.5 Calculating the $\overline{\text{RESET}}$ Pullup Resistor

The TPS36-Q1 uses an open-drain configuration for the $\overline{\text{RESET}}$ output, as shown in 图 9-2. When the FET is off, the resistor pulls the drain of the transistor to VDD and when the FET is turned on, the FET pulls the output to ground, thus creating an effective resistor divider. The resistors in this divider must be chosen to ensure that V_{OL} is below its maximum value. To choose the proper pullup resistor, there are three key specifications to keep in mind: the pullup voltage (V_{PU}), the recommended maximum $\overline{\text{RESET}}$ pin current (I_{RST}), and V_{OL} . The maximum V_{OL} is 0.3 V, meaning that the effective resistor divider created must be able to bring the voltage on the reset pin below 0.3 V with I_{RST} kept below 2 mA for $V_{DD} \geq 3$ V and 500 μA for $V_{DD} = 1.5$ V. For this example, with a $V_{PU} = V_{DD} = 1.5$ V, a resistor must be chosen to keep I_{RST} below 500 μA because this value is the maximum consumption current allowed. To ensure this specification is met, a pullup resistor value of 10 k Ω was selected, which sinks a maximum of 180 μA when $\overline{\text{RESET}}$ is asserted.



图 9-2. Open-Drain $\overline{\text{RESET}}$ Configuration

9.3 Power Supply Recommendations

This device is designed to operate from an input supply with a voltage range between 1.04 V and 6 V. An input supply capacitor is not required for this device; however, if the input supply is noisy, then good analog practice is to place a 0.1- μ F capacitor between the VDD pin and the GND pin.

9.4 Layout

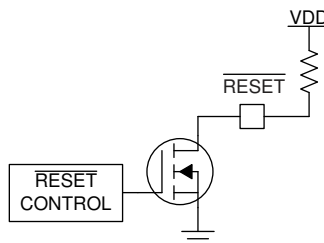
9.4.1 Layout Guidelines

Make sure that the connection to the VDD pin is low impedance. Good analog design practice recommends placing a 0.1- μ F ceramic capacitor as near as possible to the VDD pin. If a capacitor is not connected to the CRST pin, then minimize parasitic capacitance on this pin so the RESET delay time is not adversely affected.

- Make sure that the connection to the VDD pin is low impedance. Good analog design practice is to place a 0.1- μ F ceramic capacitor as near as possible to the VDD pin.
- Place C_{CRST} capacitor as close as possible to the CRST pin.
- Place C_{CWD} capacitor as close as possible to the CWD pin.
- Place the pullup resistor on the RESET pin as close to the pin as possible.

9.4.2 Layout Example

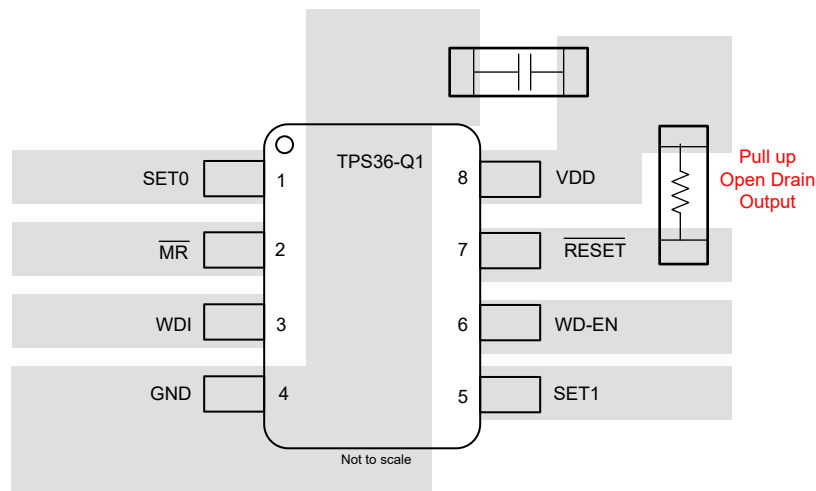

Copyright © 2023, Texas Instruments Incorporated

 **9-3. Typical Layout for the pinout C of TPS36-Q1**

10 Device and Documentation Support

10.1 ドキュメントの更新通知を受け取る方法

ドキュメントの更新についての通知を受け取るには、[ti.com](https://www.ti.com) のデバイス製品フォルダを開いてください。「更新の通知を受け取る」をクリックして登録すると、変更されたすべての製品情報に関するダイジェストを毎週受け取れます。変更の詳細については、修正されたドキュメントに含まれている改訂履歴をご覧ください。

10.2 サポート・リソース

[TI E2E™ サポート・フォーラム](#)は、エンジニアが検証済みの回答と設計に関するヒントをエキスパートから迅速かつ直接得ることができる場所です。既存の回答を検索したり、独自の質問をしたりすることで、設計に必要な支援を迅速に得ることができます。

リンクされているコンテンツは、該当する貢献者により、現状のまま提供されるものです。これらは TI の仕様を構成するものではなく、必ずしも TI の見解を反映したものではありません。TI の[使用条件](#)を参照してください。

10.3 Trademarks

TI E2E™ is a trademark of Texas Instruments.

すべての商標は、それぞれの所有者に帰属します。

10.4 静電気放電に関する注意事項



この IC は、ESD によって破損する可能性があります。テキサス・インスツルメンツは、IC を取り扱う際には常に適切な注意を払うことを推奨します。正しい取り扱いおよび設置手順に従わない場合、デバイスを破損するおそれがあります。

ESD による破損は、わずかな性能低下からデバイスの完全な故障まで多岐にわたります。精密な IC の場合、パラメータがわずかに変化するだけで公表されている仕様から外れる可能性があるため、破損が発生しやすくなっています。

10.5 用語集

[テキサス・インスツルメンツ用語集](#)

この用語集には、用語や略語の一覧および定義が記載されています。

11 Mechanical, Packaging, and Orderable Information

The following pages include mechanical, packaging, and orderable information. This information is the most current data available for the designated devices. This data is subject to change without notice and revision of this document. For browser-based versions of this data sheet, refer to the left-hand navigation.

PACKAGING INFORMATION

Orderable Device	Status (1)	Package Type	Package Drawing	Pins	Package Qty	Eco Plan (2)	Lead finish/ Ball material (6)	MSL Peak Temp (3)	Op Temp (°C)	Device Marking (4/5)	Samples
TPS36BA12ACADDFRQ1	ACTIVE	SOT-23-THIN	DDF	8	3000	RoHS & Green	NIPDAU	Level-1-260C-UNLIM	-40 to 125	NLLOA	Samples
TPS36BA38ACADDFRQ1	ACTIVE	SOT-23-THIN	DDF	8	3000	RoHS & Green	NIPDAU	Level-1-260C-UNLIM	-40 to 125	NLHOB	Samples
TPS36CA66BECDDFRQ1	ACTIVE	SOT-23-THIN	DDF	8	3000	RoHS & Green	NIPDAU	Level-1-260C-UNLIM	-40 to 125	NLHOD	Samples

(1) The marketing status values are defined as follows:

ACTIVE: Product device recommended for new designs.

LIFEBUY: TI has announced that the device will be discontinued, and a lifetime-buy period is in effect.

NRND: Not recommended for new designs. Device is in production to support existing customers, but TI does not recommend using this part in a new design.

PREVIEW: Device has been announced but is not in production. Samples may or may not be available.

OBSOLETE: TI has discontinued the production of the device.

(2) **RoHS:** TI defines "RoHS" to mean semiconductor products that are compliant with the current EU RoHS requirements for all 10 RoHS substances, including the requirement that RoHS substance do not exceed 0.1% by weight in homogeneous materials. Where designed to be soldered at high temperatures, "RoHS" products are suitable for use in specified lead-free processes. TI may reference these types of products as "Pb-Free".

RoHS Exempt: TI defines "RoHS Exempt" to mean products that contain lead but are compliant with EU RoHS pursuant to a specific EU RoHS exemption.

Green: TI defines "Green" to mean the content of Chlorine (Cl) and Bromine (Br) based flame retardants meet JS709B low halogen requirements of <=1000ppm threshold. Antimony trioxide based flame retardants must also meet the <=1000ppm threshold requirement.

(3) MSL, Peak Temp. - The Moisture Sensitivity Level rating according to the JEDEC industry standard classifications, and peak solder temperature.

(4) There may be additional marking, which relates to the logo, the lot trace code information, or the environmental category on the device.

(5) Multiple Device Markings will be inside parentheses. Only one Device Marking contained in parentheses and separated by a "~" will appear on a device. If a line is indented then it is a continuation of the previous line and the two combined represent the entire Device Marking for that device.

(6) Lead finish/Ball material - Orderable Devices may have multiple material finish options. Finish options are separated by a vertical ruled line. Lead finish/Ball material values may wrap to two lines if the finish value exceeds the maximum column width.

Important Information and Disclaimer:The information provided on this page represents TI's knowledge and belief as of the date that it is provided. TI bases its knowledge and belief on information provided by third parties, and makes no representation or warranty as to the accuracy of such information. Efforts are underway to better integrate information from third parties. TI has taken and continues to take reasonable steps to provide representative and accurate information but may not have conducted destructive testing or chemical analysis on incoming materials and chemicals. TI and TI suppliers consider certain information to be proprietary, and thus CAS numbers and other limited information may not be available for release.

In no event shall TI's liability arising out of such information exceed the total purchase price of the TI part(s) at issue in this document sold by TI to Customer on an annual basis.

TAPE AND REEL INFORMATION

QUADRANT ASSIGNMENTS FOR PIN 1 ORIENTATION IN TAPE

*All dimensions are nominal

Device	Package Type	Package Drawing	Pins	SPQ	Reel Diameter (mm)	Reel Width W1 (mm)	A0 (mm)	B0 (mm)	K0 (mm)	P1 (mm)	W (mm)	Pin1 Quadrant
TPS36BA12ACADDFRQ1	SOT-23-THIN	DDF	8	3000	180.0	8.4	3.2	3.2	1.4	4.0	8.0	Q3
TPS36BA38ACADDFRQ1	SOT-23-THIN	DDF	8	3000	180.0	8.4	3.2	3.2	1.4	4.0	8.0	Q3
TPS36CA66BECDDFRQ1	SOT-23-THIN	DDF	8	3000	180.0	8.4	3.2	3.2	1.4	4.0	8.0	Q3

TAPE AND REEL BOX DIMENSIONS

*All dimensions are nominal

Device	Package Type	Package Drawing	Pins	SPQ	Length (mm)	Width (mm)	Height (mm)
TPS36BA12ACADDFRQ1	SOT-23-THIN	DDF	8	3000	210.0	185.0	35.0
TPS36BA38ACADDFRQ1	SOT-23-THIN	DDF	8	3000	210.0	185.0	35.0
TPS36CA66BECDDFRQ1	SOT-23-THIN	DDF	8	3000	210.0	185.0	35.0

DDF0008A



PACKAGE OUTLINE

SOT-23 - 1.1 mm max height

PLASTIC SMALL OUTLINE

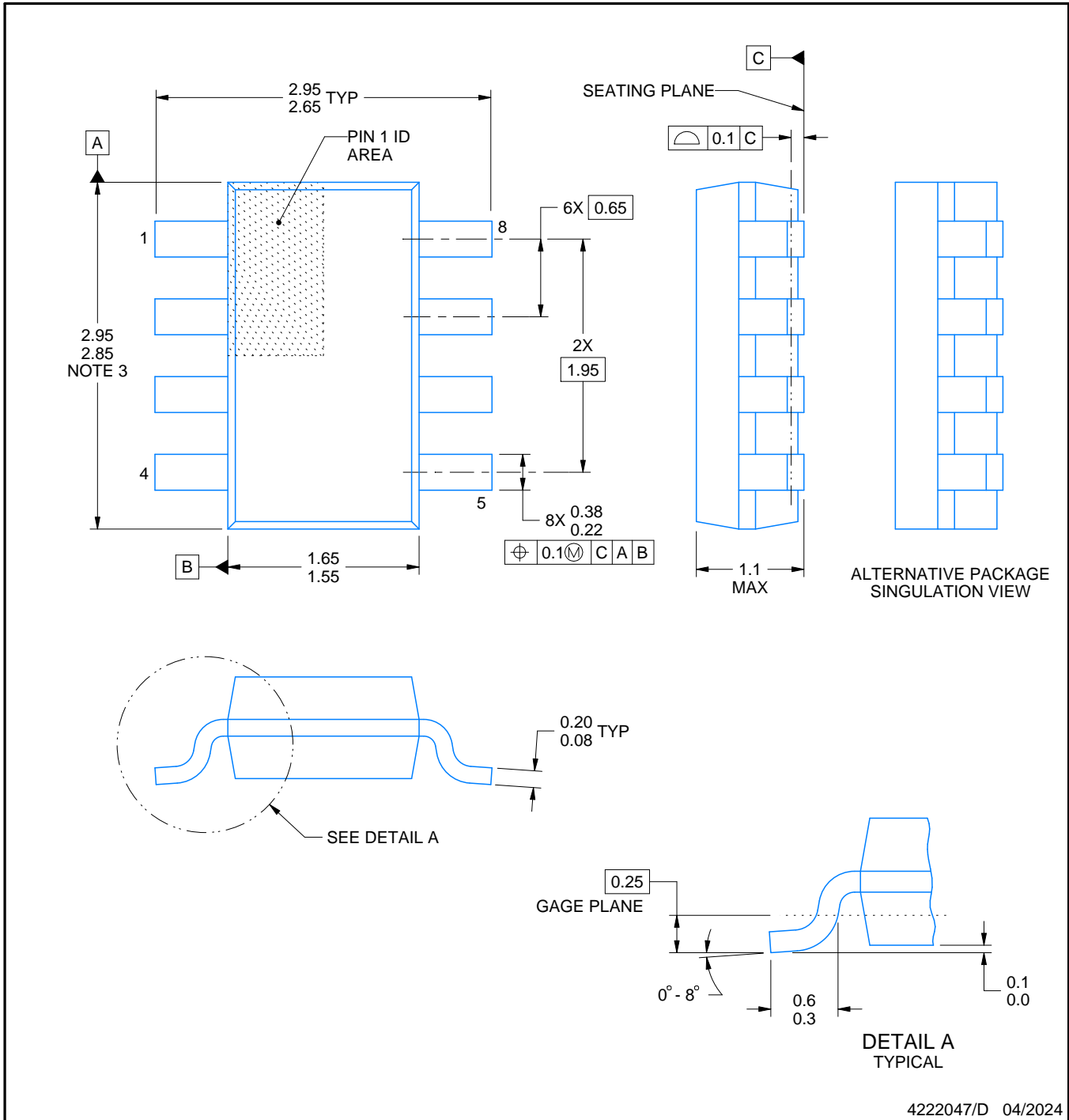

NOTES:

1. All linear dimensions are in millimeters. Any dimensions in parenthesis are for reference only. Dimensioning and tolerancing per ASME Y14.5M.
2. This drawing is subject to change without notice.
3. This dimension does not include mold flash, protrusions, or gate burrs. Mold flash, protrusions, or gate burrs shall not exceed 0.15 mm per side.

EXAMPLE BOARD LAYOUT

DDF0008A

SOT-23 - 1.1 mm max height

PLASTIC SMALL OUTLINE

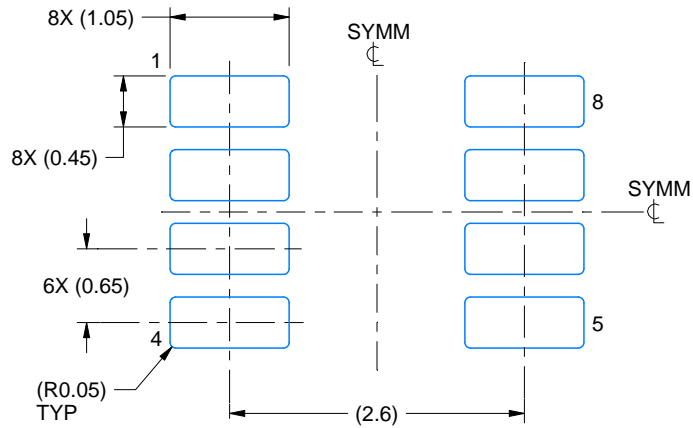

LAND PATTERN EXAMPLE
EXPOSED METAL SHOWN
SCALE:15X

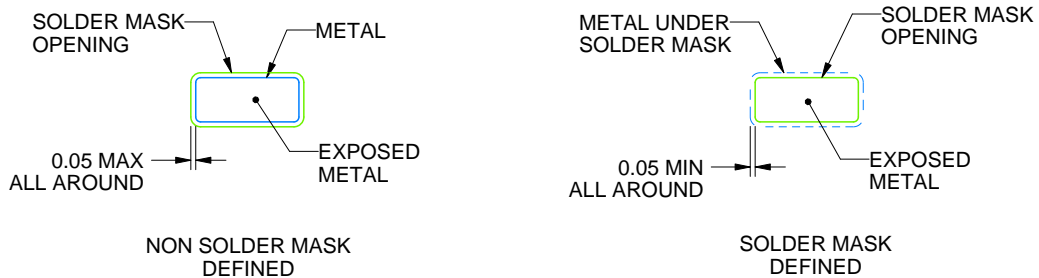

SOLDER MASK DETAILS

4222047/D 04/2024

NOTES: (continued)

- 4. Publication IPC-7351 may have alternate designs.
- 5. Solder mask tolerances between and around signal pads can vary based on board fabrication site.

EXAMPLE STENCIL DESIGN

DDF0008A

SOT-23 - 1.1 mm max height

PLASTIC SMALL OUTLINE



SOLDER PASTE EXAMPLE
BASED ON 0.125 mm THICK STENCIL
SCALE:15X

4222047/D 04/2024

NOTES: (continued)

6. Laser cutting apertures with trapezoidal walls and rounded corners may offer better paste release. IPC-7525 may have alternate design recommendations.
7. Board assembly site may have different recommendations for stencil design.

重要なお知らせと免責事項

TI は、技術データと信頼性データ (データシートを含みます)、設計リソース (リファレンス・デザインを含みます)、アプリケーションや設計に関する各種アドバイス、Web ツール、安全性情報、その他のリソースを、欠陥が存在する可能性のある「現状のまま」提供しており、商品性および特定目的に対する適合性の黙示保証、第三者の知的財産権の非侵害保証を含むいかなる保証も、明示的または黙示的にかかわらず拒否します。

これらのリソースは、TI 製品を使用する設計の経験を積んだ開発者への提供を意図したものです。(1) お客様のアプリケーションに適した TI 製品の選定、(2) お客様のアプリケーションの設計、検証、試験、(3) お客様のアプリケーションに該当する各種規格や、その他のあらゆる安全性、セキュリティ、規制、または他の要件への確実な適合に関する責任を、お客様のみが単独で負うものとし、

上記の各種リソースは、予告なく変更される可能性があります。これらのリソースは、リソースで説明されている TI 製品を使用するアプリケーションの開発の目的でのみ、TI はその使用をお客様に許諾します。これらのリソースに関して、他の目的で複製することや掲載することは禁止されています。TI や第三者の知的財産権のライセンスが付与されている訳ではありません。お客様は、これらのリソースを自身で使用した結果発生するあらゆる申し立て、損害、費用、損失、責任について、TI およびその代理人を完全に補償するものとし、TI は一切の責任を拒否します。

TI の製品は、[TI の販売条件](#)、または [ti.com](#) やかかる TI 製品の関連資料などのいずれかを通じて提供する適用可能な条項の下で提供されています。TI がこれらのリソースを提供することは、適用される TI の保証または他の保証の放棄の拡大や変更を意味するものではありません。

お客様がいかなる追加条項または代替条項を提案した場合でも、TI はそれらに異議を唱え、拒否します。

郵送先住所 : Texas Instruments, Post Office Box 655303, Dallas, Texas 75265
Copyright © 2024, Texas Instruments Incorporated