

## TPS7B4255-Q1

# 車載用、70mA、40V、電圧トラッキング LDO、5mV トラッキング許容誤差

### 1 特長

- 車載アプリケーション用に AEC-Q100 認定済み:
  - 温度グレード 1:  $-40^{\circ}\text{C} \sim +125^{\circ}\text{C}$ ,  $T_A$
  - 接合部温度:  $-40^{\circ}\text{C} \sim +150^{\circ}\text{C}$ ,  $T_J$
- 広い動作入力電圧範囲 (3V~40V)
  - 絶対最大入力電圧範囲:  $-40\text{V} \sim +45\text{V}$
- 広い出力電圧範囲: 2V~40V
- 最大出力電流: 70mA
- 非常に厳格な出力トラッキング許容誤差: 5mV (最大値)
- 低いドロップアウト電圧: 70mA 供給時に 500mV (最大値)
- 統合された基準機能とイネーブル機能
- 低い静止電流 (軽負荷時): 35 $\mu\text{A}$
- 広い  $C_{OUT}$  および ESR 範囲:
  - 1 $\mu\text{F} \sim 200\mu\text{F}$  のセラミック出力コンデンサ、1m $\Omega \sim 3\Omega$  の ESR で安定動作
- 内蔵保護機能:
  - 逆電流保護
  - 逆極性保護
  - 過熱保護
  - グラウンド / 電源への出力短絡に対する保護
- 2 種類の 5 ピン SOT-23 パッケージで供給
  - 標準 SOT-23 (DBV)
  - 熱的に強化された SOT-23 (DYB)

### 2 アプリケーション

- パワートレインの圧力センサ
- パワートレインの温度センサ
- パワートレインの排気ガス・センサ
- パワートレインの液体濃度センサ
- 車体制御モジュール (BCM)

### 3 概要

TPS7B4255-Q1 は、高いトラッキング精度と、負荷およびラインでの優れた過渡応答を実現する、低ドロップアウト (LDO) 電圧トラッキング・レギュレータです。このデバイスは、2 種類の 5 ピン SOT-23 パッケージ (DBV および DYB) で供給されます。TPS7B4255-Q1 は、パワートレイン・システムなどの車載アプリケーションにおいて、オフボードのセンサに対する電源供給用に設計されています。オフボード電力を供給するケーブルで障害のリスクが高いため、このデバイスには、逆電流 (バッテリーへの短絡)、逆極性、出力からグラウンドへの短絡 (電流制限)、過熱 (サーマル・シャットダウン) などのフォルト条件に対する保護機能が内蔵されています。このデバイスは、45V (絶対最大定格) までの入力電圧に対応し、車載負荷ダンプによる過渡条件に耐えられるように設計されています。

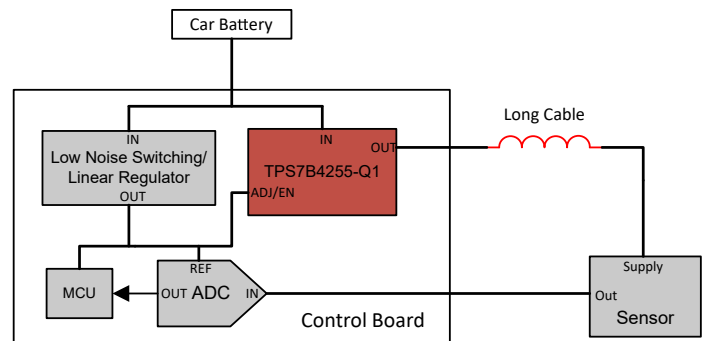
ADJ/EN ピンに印加される基準電圧は、最大 70mA の負荷の非常に厳格な許容誤差を備え、OUT ピンで効果的にトラッキングされています。したがって、TPS7B4255-Q1 はオフボード・センサに電源電圧を高精度で供給できるため、レシオメトリック・センサを使用した測定の信頼性と精度を向上させるのに役立ちます。

ADJ/EN 入力ピンを Low に設定することで、TPS7B4255-Q1 はスタンバイ・モードに切り替わり、LDO の静止電流を 3.25 $\mu\text{A}$  未満に低減できます。

#### パッケージ情報

部品番号	パッケージ (1)	パッケージ・サイズ (2)
TPS7B4255-Q1	DBV (SOT-23, 5)	2.9mm × 2.8mm
	DYB (SOT-23, 5)	2.93mm × 2.7mm

- 利用可能なすべてのパッケージについては、データシートの末尾にある注文情報を参照してください。
- パッケージ・サイズ (長さ×幅) は公称値であり、該当する場合はピンも含まれます。



#### 代表的なアプリケーション



## Table of Contents

<b>1 特長</b> .....	1	7.4 Device Functional Modes.....	15
<b>2 アプリケーション</b> .....	1	<b>8 Application and Implementation</b> .....	16
<b>3 概要</b> .....	1	8.1 Application Information.....	16
<b>4 Revision History</b> .....	2	8.2 Typical Application.....	17
<b>5 Pin Configuration and Functions</b> .....	3	8.3 Power Supply Recommendations.....	19
<b>6 Specifications</b> .....	3	8.4 Layout.....	19
6.1 Absolute Maximum Ratings.....	3	<b>9 Device and Documentation Support</b> .....	23
6.2 ESD Ratings.....	4	9.1 Device Support.....	23
6.3 Recommended Operating Conditions.....	4	9.2 ドキュメントの更新通知を受け取る方法.....	23
6.4 Thermal Information.....	4	9.3 サポート・リソース.....	23
6.5 Electrical Characteristics.....	5	9.4 Trademarks.....	23
6.6 Timing Characteristics.....	5	9.5 静電気放電に関する注意事項.....	23
6.7 Typical Characteristics.....	6	9.6 用語集.....	23
<b>7 Detailed Description</b> .....	10	<b>10 Mechanical, Packaging, and Orderable Information</b> .....	23
7.1 Overview.....	10	10.1 Mechanical Data.....	24
7.2 Functional Block Diagram.....	10		
7.3 Feature Description.....	10		

## 4 Revision History

資料番号末尾の英字は改訂を表しています。その改訂履歴は英語版に準じています。

Changes from Revision * (June 2022) to Revision A (August 2023)	Page
• ドキュメントのステータスを「事前情報」から「量産データ」に変更 .....	1

## 5 Pin Configuration and Functions

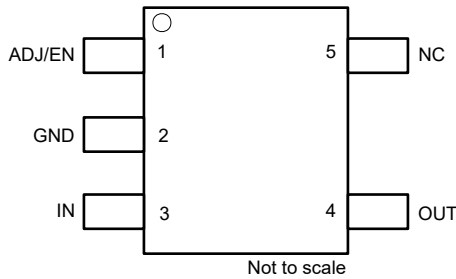


图 5-1. DBV Package, 5-Pin SOT-23 (Top View)

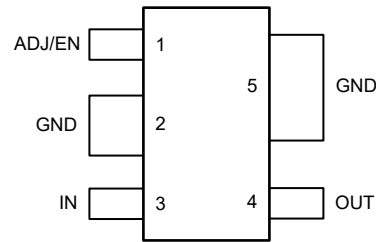


图 5-2. DYB Package, 5-Pin SOT-23 (Top View)

表 5-1. Pin Functions

NAME	PIN		TYPE	DESCRIPTION
	DBV	DYB		
ADJ/EN	1	1	I	Adjustable or enable input pin. Connect the external reference voltage to this pin. This pin connects to the error amplifier internally. A low signal below $V_{IL}$ disables the device, and a high signal above $V_{IH}$ enables the device. Connect the voltage reference directly or with a voltage divider for lower output voltages. To compensate for line influences, place a 0.1- $\mu$ F capacitor close to this pin.
GND	2	2, 5	G	Ground pin.
IN	3	3	I	Input power-supply voltage pin. This pin is the device supply. For best transient response and to minimize input impedance, use the recommended value or larger ceramic capacitor from IN to GND as listed in the <a href="#">Recommended Operating Conditions</a> table. Place the input capacitor as close to the input of the device as possible to compensate for line influences.
NC	5	—	—	NC pin. This pin is not internally connected. This pin can either be left floating or connected to GND for improved thermal performance.
OUT	4	4	O	Tracker output voltage pin. A capacitor is required from OUT to GND for stability. For best transient response, use the nominal recommended value or larger ceramic capacitor from OUT to GND; see the <a href="#">Recommended Operating Conditions</a> table. Place the output capacitor as close to output of the device as possible.

## 6 Specifications

### 6.1 Absolute Maximum Ratings

over operating free-air temperature range (unless otherwise noted)<sup>(1)</sup>

		MIN	MAX	UNIT
$V_{IN}$	Unregulated input voltage	-40	45	V
$V_{OUT}$	Tracker output voltage	-5	45	V
$V_{ADJ/EN}$	Adjustable reference and enable input voltage	-0.3	45	V
$V_{IN} - V_{OUT}$	Input output voltage difference	-40	40	V
$T_J$	Operating junction temperature	-40	150	°C
$T_{stg}$	Storage temperature	-65	150	°C

- (1) Operation outside the Absolute Maximum Ratings may cause permanent device damage. Absolute Maximum Ratings do not imply functional operation of the device at these or any other conditions beyond those listed under Recommended Operating Conditions. If used outside the Recommended Operating Conditions but within the Absolute Maximum Ratings, the device may not be fully functional, and this may affect the device reliability, functionality, performance, and shorten the device lifetime.

## 6.2 ESD Ratings

			VALUE	UNIT	
V <sub>(ESD)</sub>	Electrostatic discharge	Human-body model (HBM), per AEC Q100-002 <sup>(1)</sup>	±2000	V	
		Charged-device model (CDM), per AEC Q100-011	All pins		±500
			Corner pins		±750

(1) AEC Q100-002 indicates that HBM stressing shall be in accordance with the ANSI/ESDA/JEDEC JS-001 specification.

## 6.3 Recommended Operating Conditions

over operating free-air temperature range (unless otherwise noted)

		MIN	TYP	MAX	UNIT
V <sub>IN</sub>	Unregulated input voltage	3		40	V
V <sub>OUT</sub>	Regulated output voltage	2		40	V
V <sub>ADJ</sub>	Adjust pin voltage	2		40	V
I <sub>OUT</sub>	Output current	0		70	mA
C <sub>IN</sub>	Input capacitor <sup>(1)</sup>	0	1		µF
C <sub>OUT</sub>	Output capacitor <sup>(2)</sup>	1		200	µF
ESR	Output capacitor ESR requirements	0.001		3	Ω
T <sub>J</sub>	Operating junction temperature	–40		150	°C

(1) For robust EMI performance the minimum input capacitance recommended is 500 nF.

(2) Effective output capacitance of 500 nF minimum required for stability.

## 6.4 Thermal Information

THERMAL METRIC <sup>(1) (2)</sup>		TPS7B4255-Q1		UNIT
		DBV (SOT-23)	DYB (SOT-23)	
		5 PINS	5 PINS	
R <sub>θJA</sub>	Junction-to-ambient thermal resistance	176.3	127.8	°C/W
R <sub>θJC(top)</sub>	Junction-to-case (top) thermal resistance	75.6	59.9	°C/W
R <sub>θJB</sub>	Junction-to-board thermal resistance	44.4	16.6	°C/W
Ψ <sub>JT</sub>	Junction-to-top characterization parameter	17.9	4.4	°C/W
Ψ <sub>JB</sub>	Junction-to-board characterization parameter	44.1	16.4	°C/W
R <sub>θJC(bot)</sub>	Junction-to-case (bottom) thermal resistance	N/A	N/A	°C/W

(1) The thermal data is based on the JEDEC standard high K profile, JESD 51-7, two-signal, two-plane, four-layer board with 2-oz. copper. The copper pad is soldered to the thermal land pattern. Also, correct attachment procedure must be incorporated

(2) For more information about traditional and new thermal metrics, see the [Semiconductor and IC Package Thermal Metrics](#) application note.

## 6.5 Electrical Characteristics

specified at  $T_J = -40^\circ\text{C}$  to  $+150^\circ\text{C}$ ,  $V_{IN} = 13.5\text{ V}$ ,  $I_{OUT} = 100\ \mu\text{A}$ ,  $C_{OUT} = 1\ \mu\text{F}$ ,  $1\ \text{m}\Omega \leq C_{OUT}\ \text{ESR} \leq 3\ \Omega$ ,  $C_{IN} = 1\ \mu\text{F}$ , and  $V_{ADJ} = 5\text{ V}$  (unless otherwise noted); typical values are at  $T_J = 25^\circ\text{C}$

PARAMETER		TEST CONDITIONS	MIN	TYP	MAX	UNIT
$\Delta V_{OUT}$	Output voltage tracking accuracy	$V_{IN} = V_{OUT} + 600\ \text{mV}$ to 40 V, $I_{OUT} = 100\ \mu\text{A}$ to 70 mA	-5		5	mV
$\Delta V_{OUT(\Delta V_{IN})}$	Line regulation	$V_{IN} = V_{OUT} + 600\ \text{mV}$ to 40 V			0.5	mV
$\Delta V_{OUT(\Delta I_{OUT})}$	Load regulation	$V_{IN} = V_{OUT} + 600\ \text{mV}$ , $I_{OUT} = 100\ \mu\text{A}$ to 70 mA <sup>(1)</sup>			0.6	mV
$I_Q$	Quiescent current	$V_{IN} = 5.6\ \text{V}$ to 40 V, $I_{OUT} = 100\ \mu\text{A}$ , $T_J = 25^\circ\text{C}$		35	40	$\mu\text{A}$
		$V_{IN} = 5.6\ \text{V}$ to 40 V, $I_{OUT} = 100\ \mu\text{A}$ , $-40^\circ\text{C} < T_J < 85^\circ\text{C}$			45	
		$V_{IN} = 5.6\ \text{V}$ to 40 V, $I_{OUT} = 100\ \mu\text{A}$			50	
$I_{GND}$	Ground current	$V_{IN} = 5.6\ \text{V}$ to 40 V, $I_{OUT} = 70\ \text{mA}$ , $T_J = 25^\circ\text{C}$			470	$\mu\text{A}$
		$V_{IN} = 5.6\ \text{V}$ to 40 V, $I_{OUT} = 70\ \text{mA}$			550	
$V_{DO}$	Dropout voltage	$I_{OUT} = 70\ \text{mA}$ , $V_{ADJ} \geq 5\ \text{V}$ , $V_{IN} = V_{ADJ}$			500	mV
		$I_{OUT} = 50\ \text{mA}$ , $V_{ADJ} \geq 5\ \text{V}$ , $V_{IN} = V_{ADJ}$			365	
$I_{SHUTDOWN}$	Shutdown supply current ( $I_{GND}$ )	$V_{ADJ/EN} = 0\ \text{V}$			3.25	$\mu\text{A}$
$I_{ADJ/EN}$	ADJ/EN pin current				0.3	$\mu\text{A}$
$V_{UVLO(RISING)}$	Rising input supply UVLO	$V_{IN}$ rising	2.6	2.7	2.81	V
$V_{UVLO(FALLING)}$	Falling input supply UVLO	$V_{IN}$ falling	2.3	2.4	2.5	V
$V_{UVLO(HYST)}$	$V_{UVLO(IN)}$ hysteresis			300		mV
$V_{IL}$	Adjustable and enable logic input low level				0.85	V
$V_{IH}$	Adjustable and enable logic input high level		1.75			
$I_{CL}$	Output current limit	$V_{IN} = V_{OUT} + 1\ \text{V}$ , $V_{OUT}$ short to $90\% \times V_{ADJ}$	75	105	130	mA
PSRR	Power-supply ripple rejection	$V_{IN} - V_{OUT} = 1\ \text{V}$ , frequency = 100 Hz, $I_{OUT} = 70\ \text{mA}$		80		dB
$V_n$	Output noise voltage	$V_{OUT} = 3.3\ \text{V}$ , $I_{OUT} = 1\ \text{mA}$ , BW = 10 Hz to 100 kHz, a $5\ \mu\text{V}_{RMS}$ reference is used for this measurement		150		$\mu\text{V}_{RMS}$
$I_{REV}$	Reverse current at $V_{IN}$	$V_{IN} = 0\ \text{V}$ , $V_{OUT} = 20\ \text{V}$ , $V_{ADJ} = 5\ \text{V}$	-0.25		0.25	$\mu\text{A}$
$I_{REV-N1}$	Reverse current at negative $V_{IN}$	$V_{IN} = -20\ \text{V}$ , $V_{OUT} = 20\ \text{V}$ , $V_{ADJ} = 5\ \text{V}$	-0.5		0.5	
$I_{REV-N2}$	Reverse current at negative $V_{IN}$	$V_{IN} = -20\ \text{V}$ , $V_{OUT} = 0\ \text{V}$ , $V_{ADJ} = 5\ \text{V}$	-0.5		0.5	
$T_J$	Junction temperature		-40		150	$^\circ\text{C}$
$T_{SD(SHUTDOWN)}$	Junction shutdown temperature			175		$^\circ\text{C}$
$T_{SD(HYST)}$	Hysteresis of thermal shutdown			15		$^\circ\text{C}$

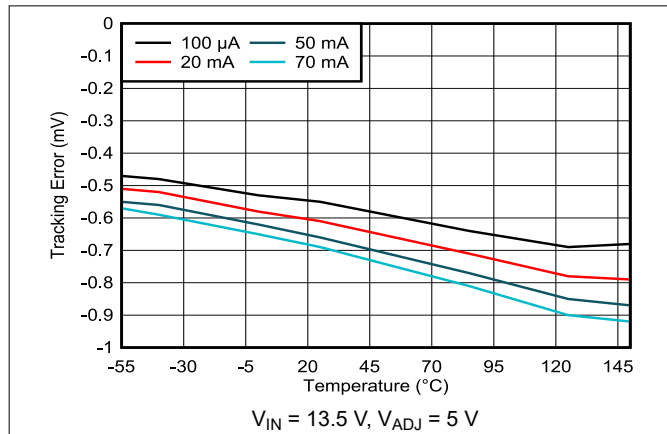
(1) Power dissipation is limited to 2 W for device production testing purposes. The power dissipation can be higher during normal operation. Please see the thermal dissipation section for more information on how much power the device can dissipate while maintaining a junction temperature below  $150^\circ\text{C}$ .

## 6.6 Timing Characteristics

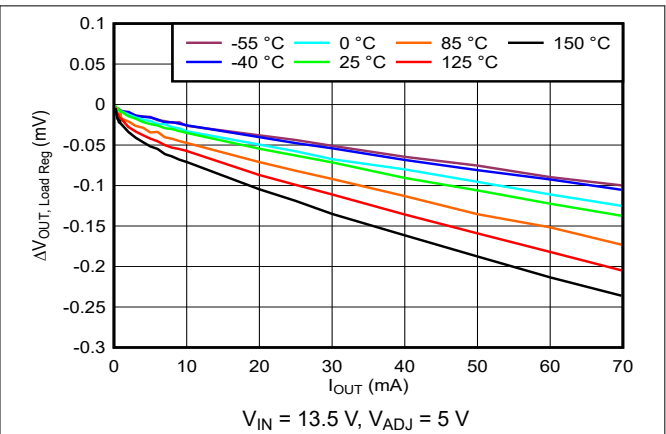
specified at  $V_{IN} = 13.5\ \text{V}$ ,  $I_{OUT} = 100\ \mu\text{A}$ ,  $C_{OUT} = 1\ \mu\text{F}$ ,  $C_{IN} = 1\ \mu\text{F}$ , and  $V_{ADJ} = 5\ \text{V}$  (unless otherwise noted), and  $V_{ADJ} = 5\ \text{V}$  (unless otherwise noted); typical values are at  $T_J = 25^\circ\text{C}$

PARAMETER		TEST CONDITIONS	MIN	TYP	MAX	UNIT
<b>Timing Characteristics</b>						
$t_{startup}$	Start-up time	Time from EN high to $V_{OUT} = 95\% \times V_{ADJ}$		255		$\mu\text{s}$

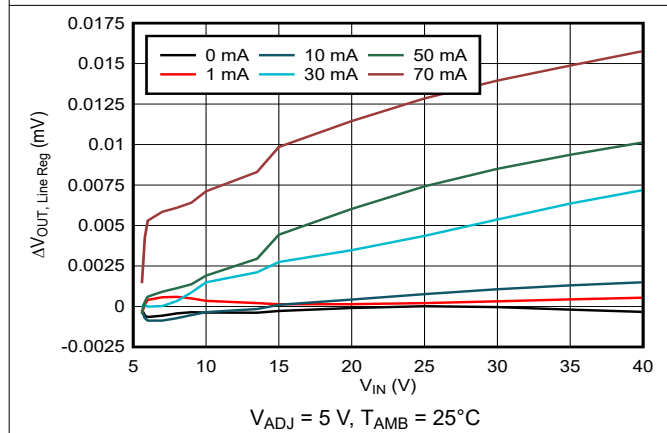
## 6.7 Typical Characteristics



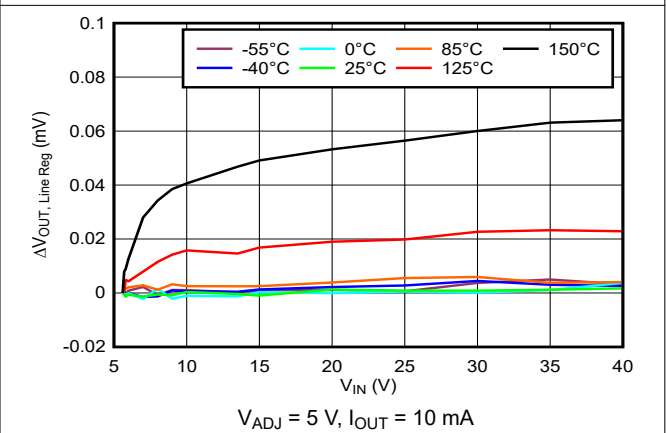
6-1. Tracking Error vs Ambient Temperature



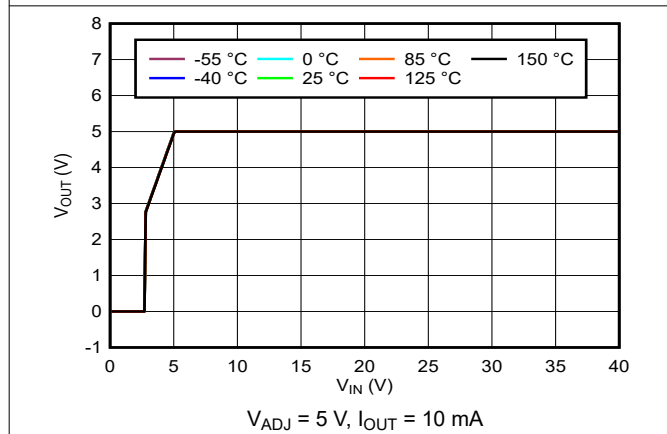
6-2. Load Regulation



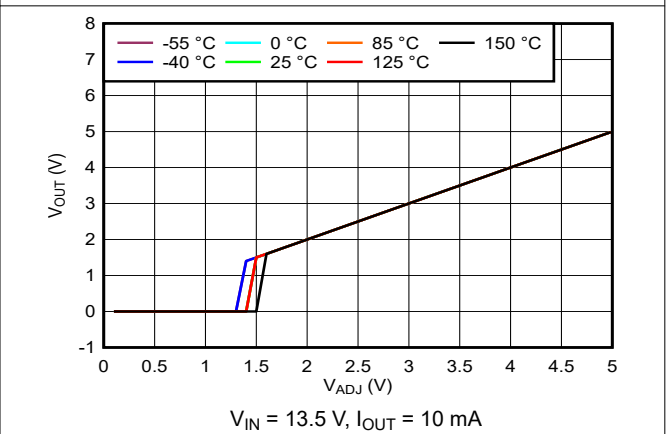
6-3. Line Regulation



6-4. Line Regulation

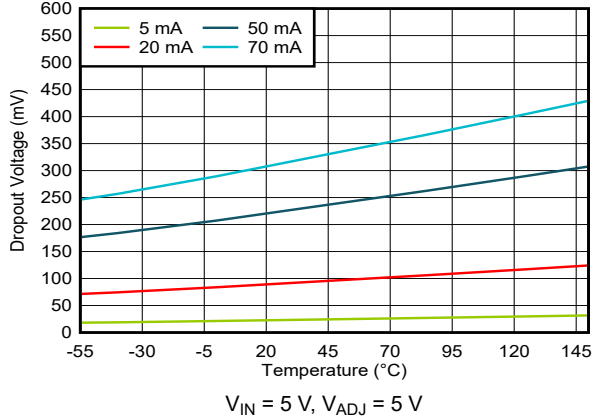


6-5. Output Voltage vs Input Voltage

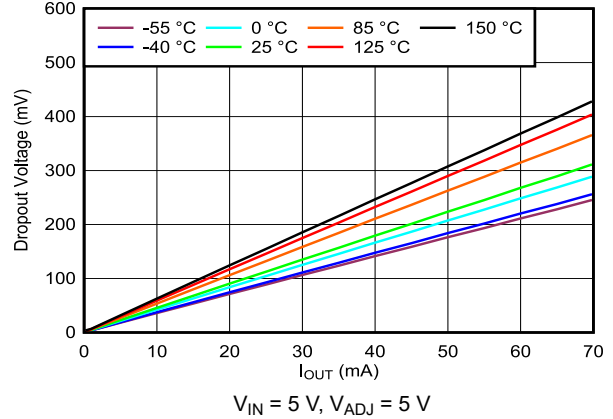


6-6. Output Voltage vs Adjustable Reference Voltage

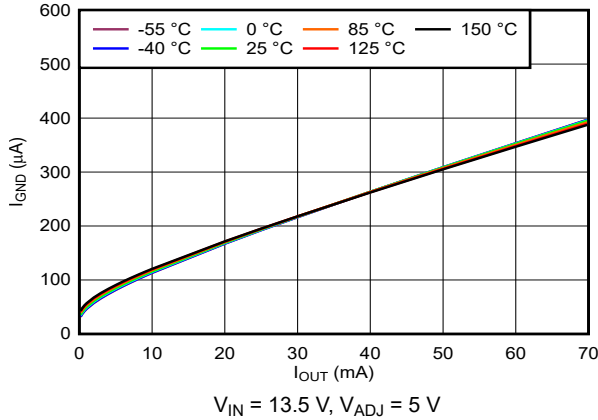
### 6.7 Typical Characteristics (continued)



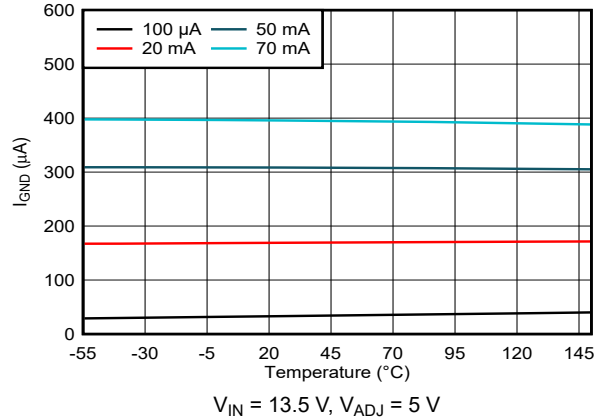
6-7. Dropout Voltage vs Ambient Temperature



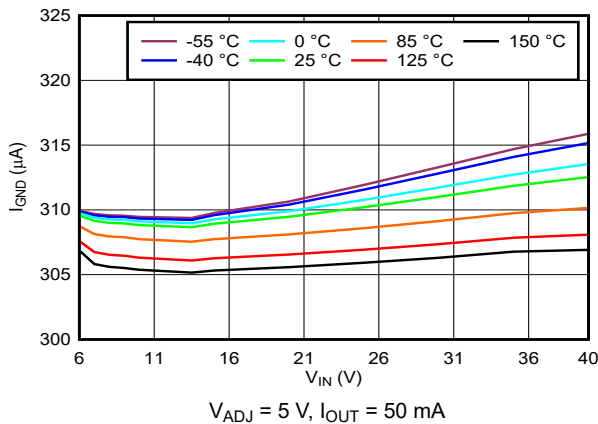
6-8. Dropout Voltage vs Output Current



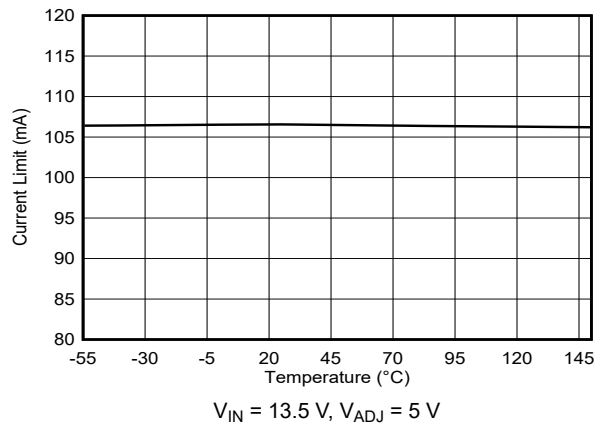
6-9. Ground Current vs Output Current



6-10. Ground Current vs Ambient Temperature

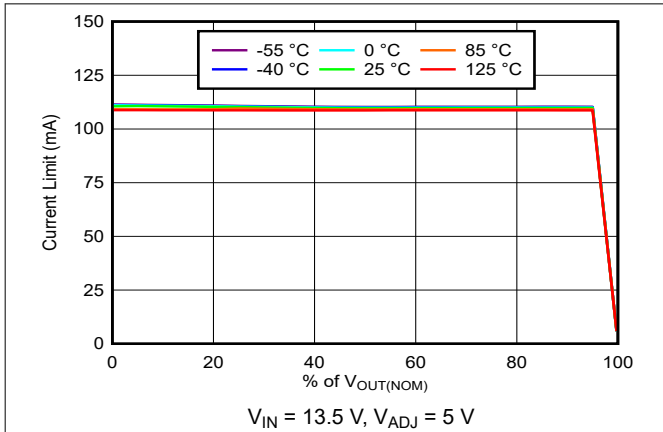


6-11. Ground Current vs Input Voltage

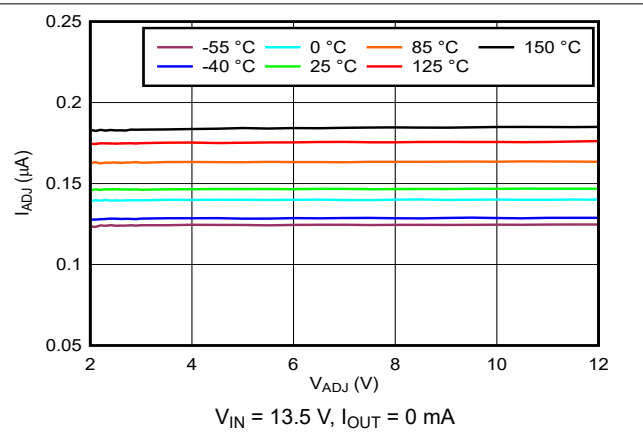


6-12. Current Limit vs Ambient Temperature

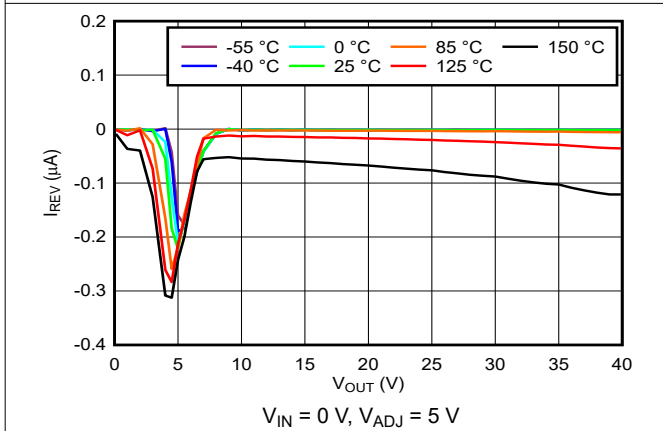
### 6.7 Typical Characteristics (continued)



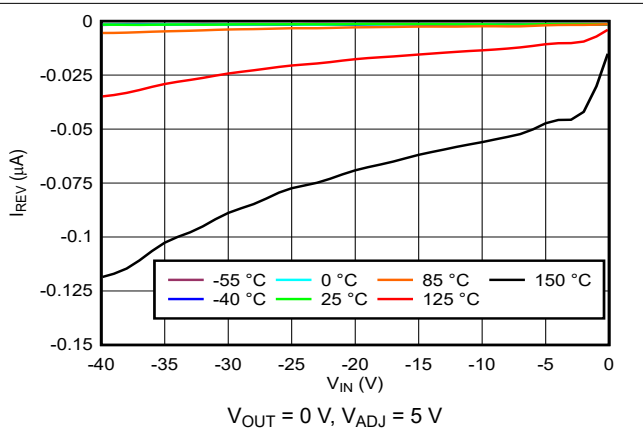
6-13. Current Limit Profile vs. Output Voltage



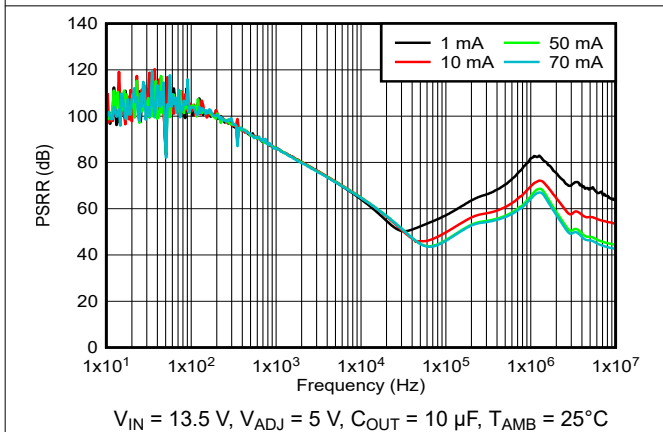
6-14. Adjustable Pin Current vs. Adjustable Pin Voltage



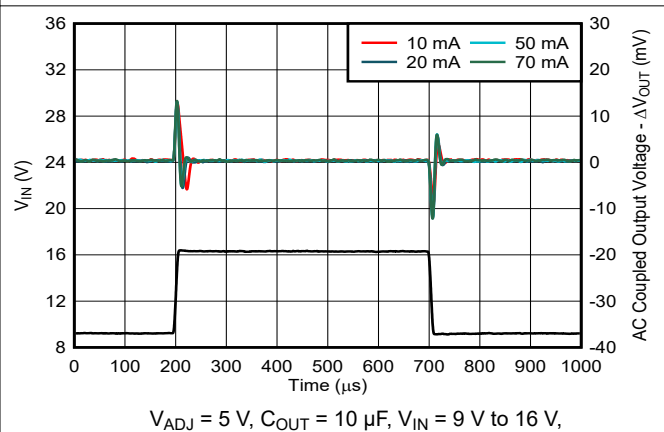
6-15. Reverse Current vs. Output Voltage



6-16. Reverse Current vs. Input Voltage



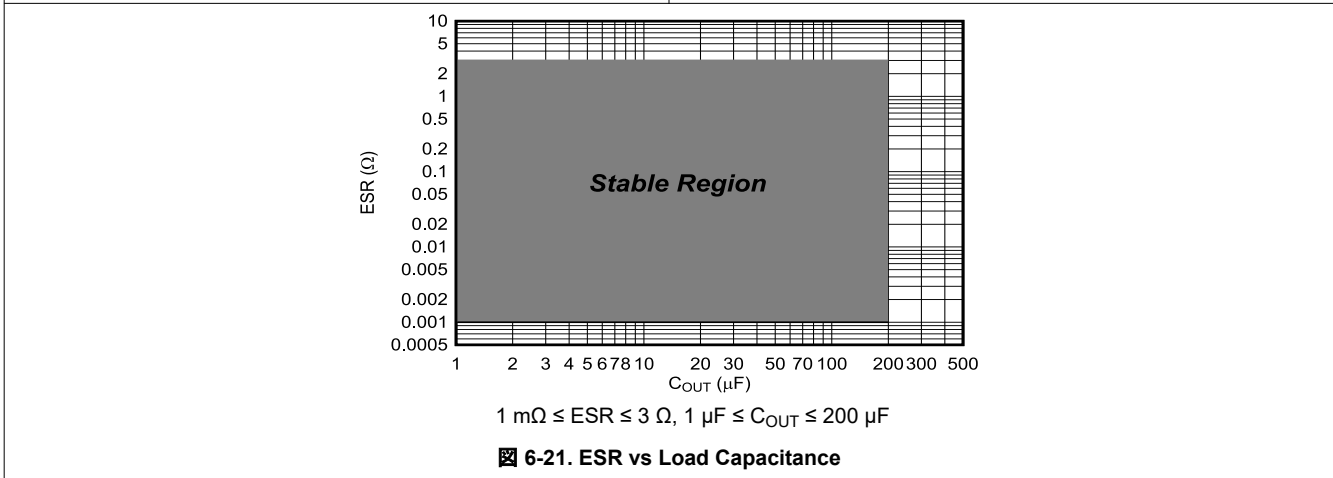
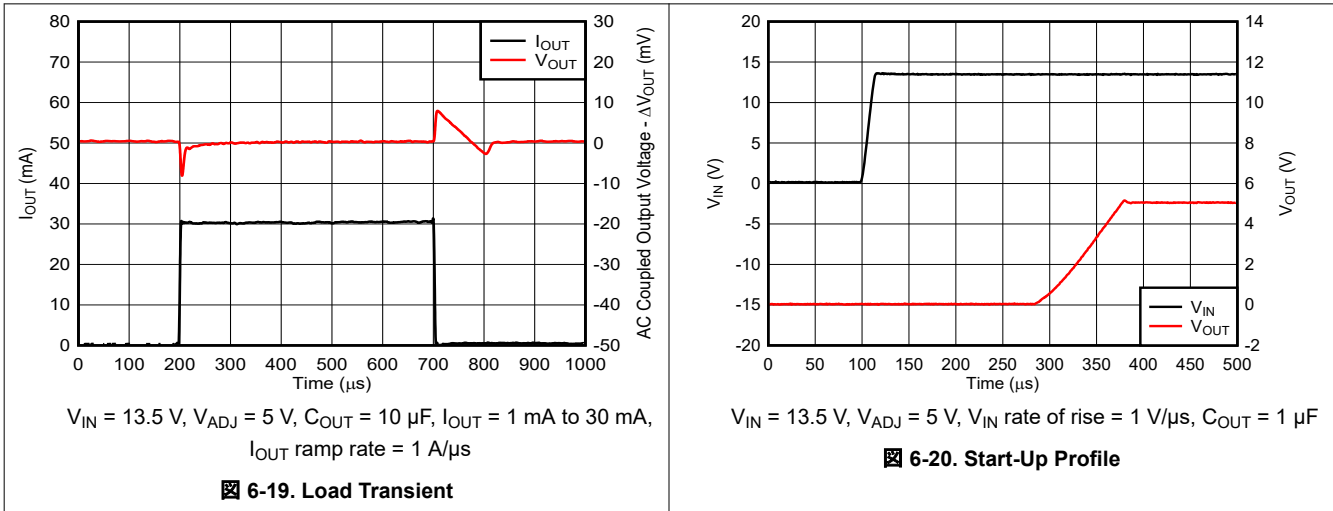
6-17. Power-Supply Rejection Ratio vs. Frequency



6-18. Line Transient



### 6.7 Typical Characteristics (continued)



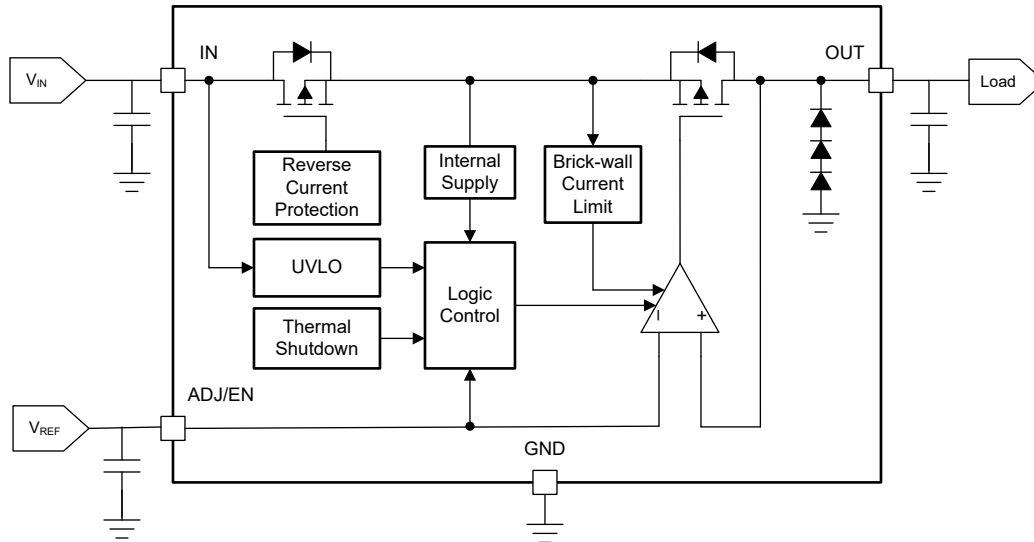
## 7 Detailed Description

### 7.1 Overview

The TPS7B4255-Q1 is an integrated, low-dropout (LDO) voltage tracker with ultra-low tracking tolerance. Because of the high risk of cable shorts when powering sensors off-board, multiple protection features are built into the LDO including short to battery, short to GND, and reverse current protection.

This device features thermal shutdown protection, brick-wall current limiting, undervoltage lockout (UVLO), reverse current, and reverse polarity protection.

### 7.2 Functional Block Diagram



7-1. Functional Block Diagram

### 7.3 Feature Description

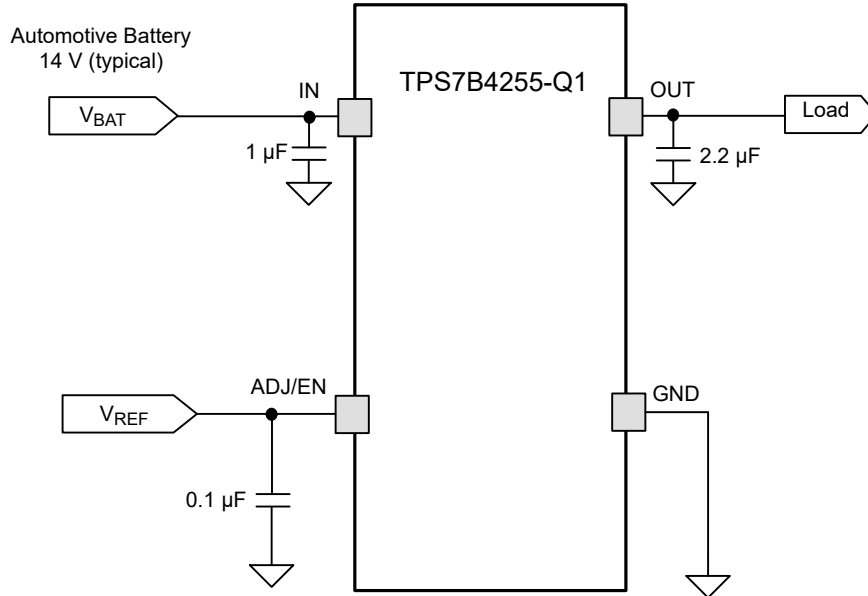
#### 7.3.1 Tracker Output Voltage ( $V_{OUT}$ )

This device is a tracking LDO; thus, with sufficient  $V_{IN}$  ( $\geq 3$  V) applied, the output voltage is determined by the voltage provided to the ADJ/EN pin. The LDO remains disabled as long as  $V_{ADJ/EN}$  is less than  $V_{IL}$ . When  $V_{ADJ/EN}$  exceeds  $V_{IH}$ , the output begins to rise to the voltage on the ADJ/EN pin. The output rises linearly as determined by the load, the output capacitor, and the current limit. When the voltage reaches the level on the ADJ/EN pin, the output voltage remains within 5 mV from the voltage set on the ADJ/EN pin over all specified operating conditions.

### 7.3.1.1 Output Voltage Equal to the Reference Voltage

As shown in [Figure 7-2](#), connect the external reference voltage directly to the ADJ/EN pin. When connected properly, and as given in [Equation 1](#), the LDO output voltage is equal to the reference voltage.

$$V_{OUT} = V_{REF} \quad (1)$$

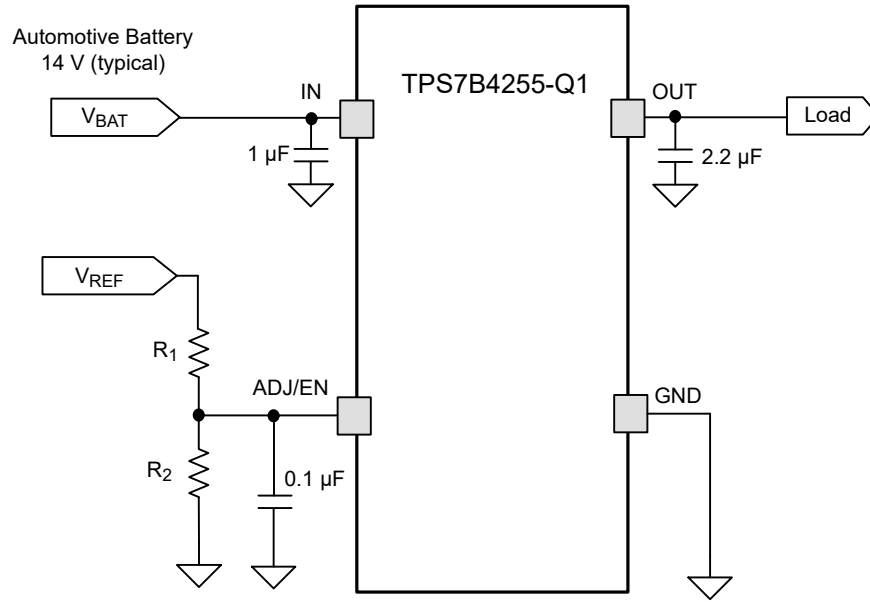


**Figure 7-2. Tracker Output Voltage Equal to the Reference Voltage**

### 7.3.1.2 Output Voltage Less Than the Reference Voltage

Connecting an external resistor divider at the ADJ/EN pin, as shown in [Figure 7-3](#), can help generate an output voltage that is lower than the reference voltage. Both the  $R_1$  and  $R_2$  resistors must be less than 100 kΩ in value. [Equation 2](#) calculates  $V_{OUT}$ .

$$V_{OUT} = \frac{V_{REF} * R_2}{R_1 + R_2} \quad (2)$$



✎ 7-3. Tracker Output Voltage Lower Than the Reference Voltage

### 7.3.2 Reverse Current Protection

The TPS7B4255-Q1 incorporates a back-to-back PMOS topology that protects the device from damage against a fault condition, resulting in  $V_{OUT}$  being higher than  $V_{IN}$  and the subsequent flow of reverse current. No damage occurs to the device if this fault condition occurs, provided the *Absolute Maximum Ratings* are not violated. This integrated protection feature eliminates the need for an external diode. The reverse current comparator typically responds to a reverse voltage condition in 1  $\mu$ s, and along with the body diode of the blocking PMOS transistor, limits the reverse current to  $I_{REV}$ .

### 7.3.3 Undervoltage Lockout

The device has an internally fixed undervoltage lockout threshold. Undervoltage lockout activates when the input voltage  $V_{IN}$  drops below the undervoltage lockout (UVLO) level; see the  $V_{UVLO(FALLING)}$  parameter in the *Electrical Characteristics* table. This activation makes sure the regulator is not latched into an unknown state during a low input supply voltage. If the input voltage has a negative transient that drops below the UVLO threshold and recovers, the regulator shuts down and powers up in the standard power-up sequence when the input voltage recovers to the required level (see the  $V_{UVLO(RISING)}$  parameter in the *Electrical Characteristics* table).

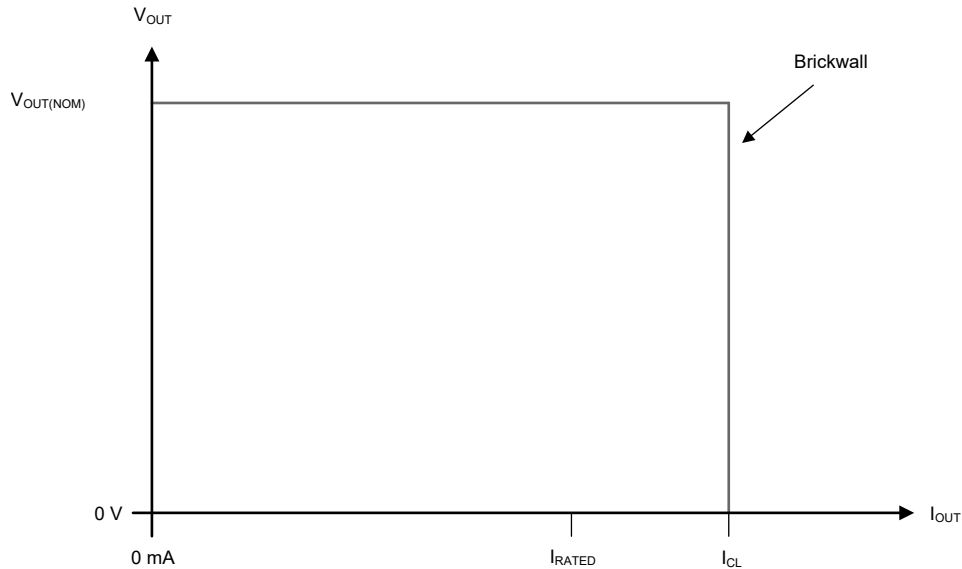
### 7.3.4 Thermal Protection

Thermal protection disables the output when the junction temperature rises to approximately 175°C, which allows the device to cool. When the junction temperature cools to approximately 160°C, the output circuitry enables. Based on power dissipation, thermal resistance, and ambient temperature, the thermal protection circuit can cycle off and on until the excessive power dissipation condition is removed. This cycling limits the dissipation of the regulator, thus protecting the regulator from damage as a result of overheating.

The internal protection circuitry of the TPS7B4255-Q1 is designed to protect against overload conditions. The circuitry is not intended to replace proper heat sinking. Continuously running the TPS7B4255-Q1 into thermal shutdown degrades device reliability.

### 7.3.5 Current Limit

The device has an internal current limit circuit to protect the device during overcurrent or shorting conditions. The current limit circuit, as shown in ✎ 7-4, is a brick-wall scheme. When the device is in current limit, the device sources  $I_{CL}$  and the output voltage is not regulated. In this scenario, the output voltage depends on the load impedance.

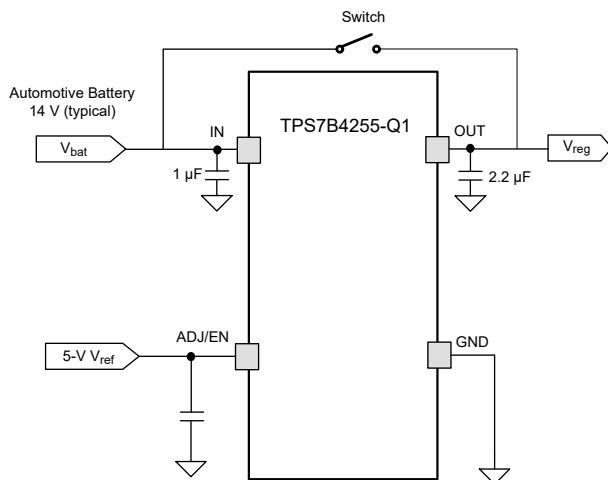


**Figure 7-4. Current Limit: Brick-Wall Scheme**

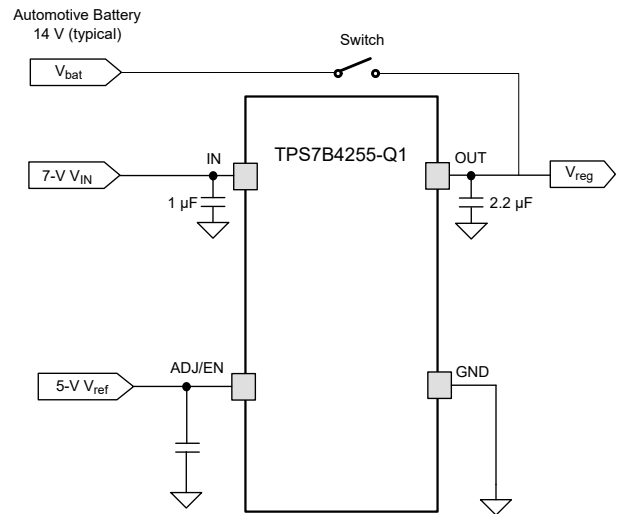
During a current limit event, the potential for high power dissipation exists because of the elevated current level and the increased input-to-output differential voltage ( $V_{IN} - V_{OUT}$ ). If the device heats enough, the device can enter thermal shutdown. If the current-limit condition is not removed when the device turns back on after cooling, the device can enter thermal shutdown again and continue this cycle until the current limit condition is removed. The device survives this fault, but repeatedly operating in this mode degrades long-term reliability.

### 7.3.6 Output Short to Battery

When the output is shorted to the supply (as shown in Figure 7-5), the TPS7B4255-Q1 survives and no damage occurs to the device. As shown in Figure 7-6, a short to the supply can also occur when the device is powered by an isolated supply at a lower voltage. In this example, the TPS7B4255-Q1 supply input voltage is set at 7 V when a short to the main supply (14 V typical) occurs on  $V_{OUT}$ , which typically runs at 5 V. The device survives without damage, and the back-to-back PMOS topology helps limit the continuous reverse current that flows out through  $V_{IN}$  to less than 0.25  $\mu$ A.



**Figure 7-5. Output Voltage Short to Battery**



**Figure 7-6. Output Voltage Higher Than the Input**

### 7.3.7 Tracking Regulator With an Enable Circuit

Pulling the reference voltage below  $V_{IL}$  disables the device, and the device enters a sleep state where the device draws 3.25  $\mu\text{A}$  (maximum) from the power supply. In a typical application, the reference voltage is generally sourced from another LDO voltage rail. A scenario where the device must be disabled without a shutdown of the reference voltage can occur; the device can be configured as shown in [Figure 7-7](#) in this case. The TPS7B84-Q1 is a 150-mA LDO with ultra-low quiescent current that provides the reference voltage to both the TPS7B4255-Q1 and the ADC. The operational status of the device is controlled by a microcontroller (MCU) input or output (I/O).

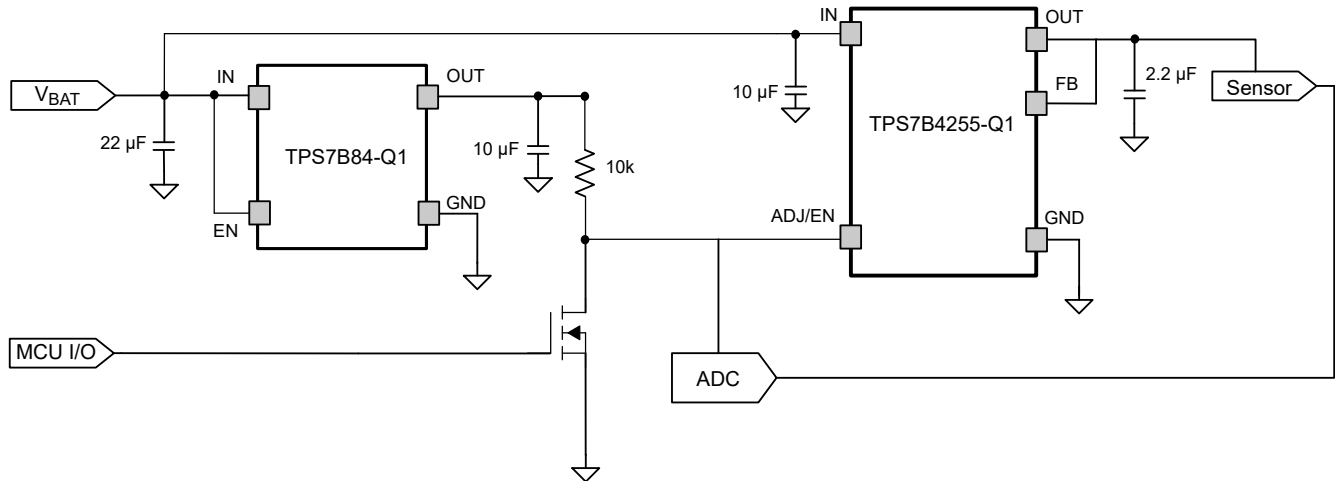


Figure 7-7. Tracking an LDO With an Enable Circuit

## 7.4 Device Functional Modes

表 7-1 shows the conditions that lead to the different modes of operation. See the [Electrical Characteristics](#) table for parameter values.

**表 7-1. Device Functional Mode Comparison**

OPERATING MODE	PARAMETER			
	$V_{IN}$	$V_{ADJ/EN}$	$I_{OUT}$	$T_J$
Normal operation	$V_{IN} > V_{OUT(Nom)} + V_{DO}$ and $V_{IN} \geq V_{IN(min)}$	$V_{ADJ/EN} > V_{IH}$	$I_{OUT} \leq I_{OUT(max)}$	$T_J < T_{SD(shutdown)}$
Dropout operation	$V_{IN(min)} < V_{IN} < V_{OUT(nom)} + V_{DO}$	$V_{ADJ/EN} > V_{IH}$	$I_{OUT} \leq I_{OUT(max)}$	$T_J < T_{SD(shutdown)}$
Disabled (any true condition disables the device)	$V_{IN} < V_{UVLO}$	$V_{ADJ/EN} < V_{IL}$	Not applicable	$T_J > T_{SD(shutdown)}$

The device turns on when  $V_{IN}$  is greater than  $V_{UVLO(RISING)}$  and  $V_{ADJ/EN}$  is greater than the enable rising threshold  $V_{IH}$ .

### 7.4.1 Normal Operation

The device output voltage  $V_{OUT(Nom)}$  tracks the reference voltage  $V_{ADJ/EN}$  when the following conditions are met:

- The input voltage is at least 3 V ( $V_{IN(min)}$ ) and greater than the nominal output voltage plus the dropout voltage ( $V_{OUT(nom)} + V_{DO}$ )
- The reference voltage at the ADJ/EN pin is greater than the enable rising threshold  $V_{IH}$  and stays stable at  $V_{OUT(Nom)}$
- The output current is less than  $I_{OUT(max)}$  ( $I_{OUT} \leq 70$  mA)
- The device junction temperature is less than the thermal shutdown temperature ( $T_J < T_{SD}$ )

### 7.4.2 Dropout Operation

If the input voltage is lower than the nominal output voltage plus the specified dropout voltage, but all other conditions are met for normal operation, the device operates in dropout mode. In this mode, the output voltage tracks the input voltage. During this mode, the transient performance of the device becomes significantly degraded because the pass transistor is in the ohmic or triode region, and acts as a switch. Line or load transients in dropout can result in large output-voltage deviations.

When the device is in a steady dropout state (defined as when the device is in dropout,  $V_{IN} < V_{OUT(NOM)} + V_{DO}$ , directly after being in a normal regulation state, but *not* during start up), the pass transistor is driven into the ohmic or triode region. When the input voltage returns to a value greater than or equal to the nominal output voltage plus the dropout voltage ( $V_{OUT(NOM)} + V_{DO}$ ), the output voltage can overshoot for a short period of time while the device pulls the pass transistor back into the saturation region.

### 7.4.3 Operation With $V_{IN} < 3$ V

For input voltages below 3 V and above  $V_{UVLO(FALLING)}$ , the LDO continues to operate but certain circuits can possibly not have the proper headroom to operate within specification. When the input voltage drops below  $V_{UVLO(FALLING)}$  the device shuts off.

### 7.4.4 Disable With ADJ/EN Control

The ADJ/EN pin operates as both the reference and the enable pin to the LDO. The output of the device can be shutdown by forcing  $V_{ADJ/EN}$  less than  $V_{IL}$ . When disabled, the pass transistor is turned off, the internal circuits are shutdown, and the LDO is in a low-power mode.

## 8 Application and Implementation

### 注

以下のアプリケーション情報は、TI の製品仕様に含まれるものではなく、TI ではその正確性または完全性を保証いたしません。個々の目的に対する製品の適合性については、お客様の責任で判断していただくこととなります。お客様は自身の設計実装を検証しテストすることで、システムの機能を確認する必要があります。

### 8.1 Application Information

#### 8.1.1 Dropout Voltage

Dropout voltage ( $V_{DO}$ ) is defined as the input voltage minus the output voltage ( $V_{IN} - V_{OUT}$ ) when the pass transistor is fully on. This condition arises when the input voltage falls to the point where the error amplifier must drive the gate of the pass transistor to the rail and has no remaining headroom for the control loop to operate. The pass transistor is in the ohmic or triode region of operation, and acts as a switch. The dropout voltage directly specifies a minimum input voltage greater than the nominal programmed output voltage at which the output voltage is expected to stay in regulation. If the input voltage falls to less than the nominal output regulation, then the output voltage follows, minus the dropout voltage ( $V_{DO}$ ).

In dropout mode, the output is no longer regulated, and transient performance is severely degraded. The device loses PSRR, and load transients can cause large output voltage deviation.

For a CMOS regulator, the dropout voltage is determined by the drain-source on-state resistance ( $R_{DS(ON)}$ ) of the pass transistor. Therefore, if the linear regulator operates at less than the rated output current ( $I_{RATED}$ , see the [Recommended Operating Conditions](#) table), the dropout voltage for that current scales accordingly. The following equation calculates the  $R_{DS(ON)}$  of the device.

$$R_{DS(ON)} = \frac{V_{DO}}{I_{RATED}} \quad (3)$$

#### 8.1.2 Reverse Current

The TPS7B4255-Q1 incorporates reverse current protection that prevents damage from a fault condition, resulting in  $V_{OUT}$  being higher than  $V_{IN}$ . During such a fault condition, where the  $V_{IN}$  and  $V_{OUT}$  absolute maximum ratings are not violated and  $V_{OUT} - V_{IN}$  is less than 40 V, no damage occurs and less than 0.5  $\mu$ A of reverse current flows through the LDO. The reverse current comparator typically responds to a reverse voltage condition and, along with the body diode of the blocking PMOS transistor, limits the reverse current in 1  $\mu$ s.



## 8.2 Typical Application

Figure 8-1 shows a typical application circuit for the TPS7B4255-Q1.

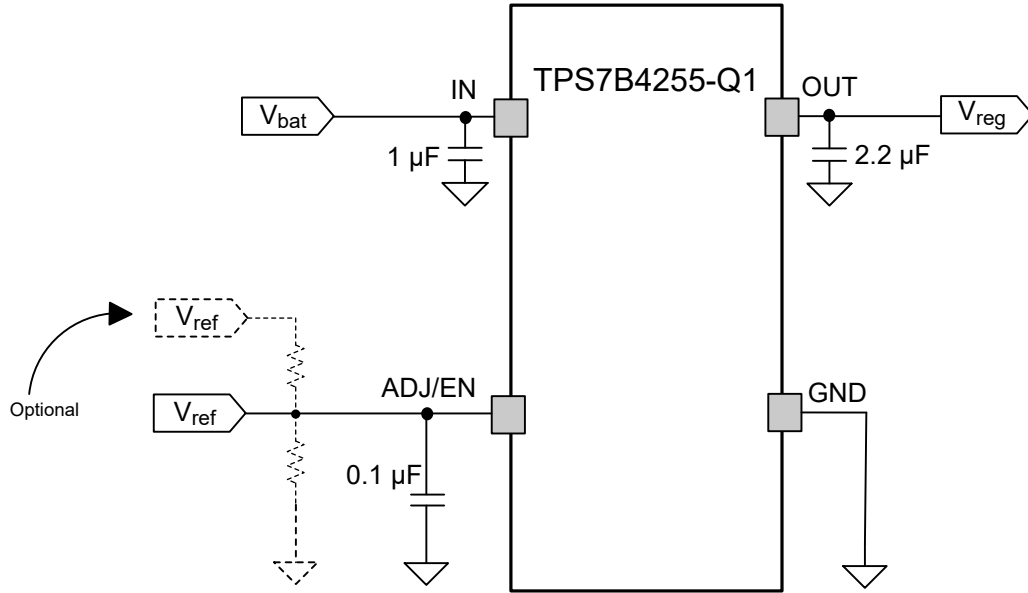


Figure 8-1. Typical Application Schematic

### 8.2.1 Design Requirements

Use the parameters listed in Table 8-1 for this design example.

Table 8-1. Design Parameters

DESIGN PARAMETER	EXAMPLE VALUES
Input voltage	3 V to 40 V
ADJ/EN reference voltage	2 V to 40 V
Output voltage	2 V to 40 V
Output current rating	70 mA
Output capacitor range	1 µF to 200 µF
Output capacitor ESR range	1 mΩ to 3 Ω

## 8.2.2 Detailed Design Procedure

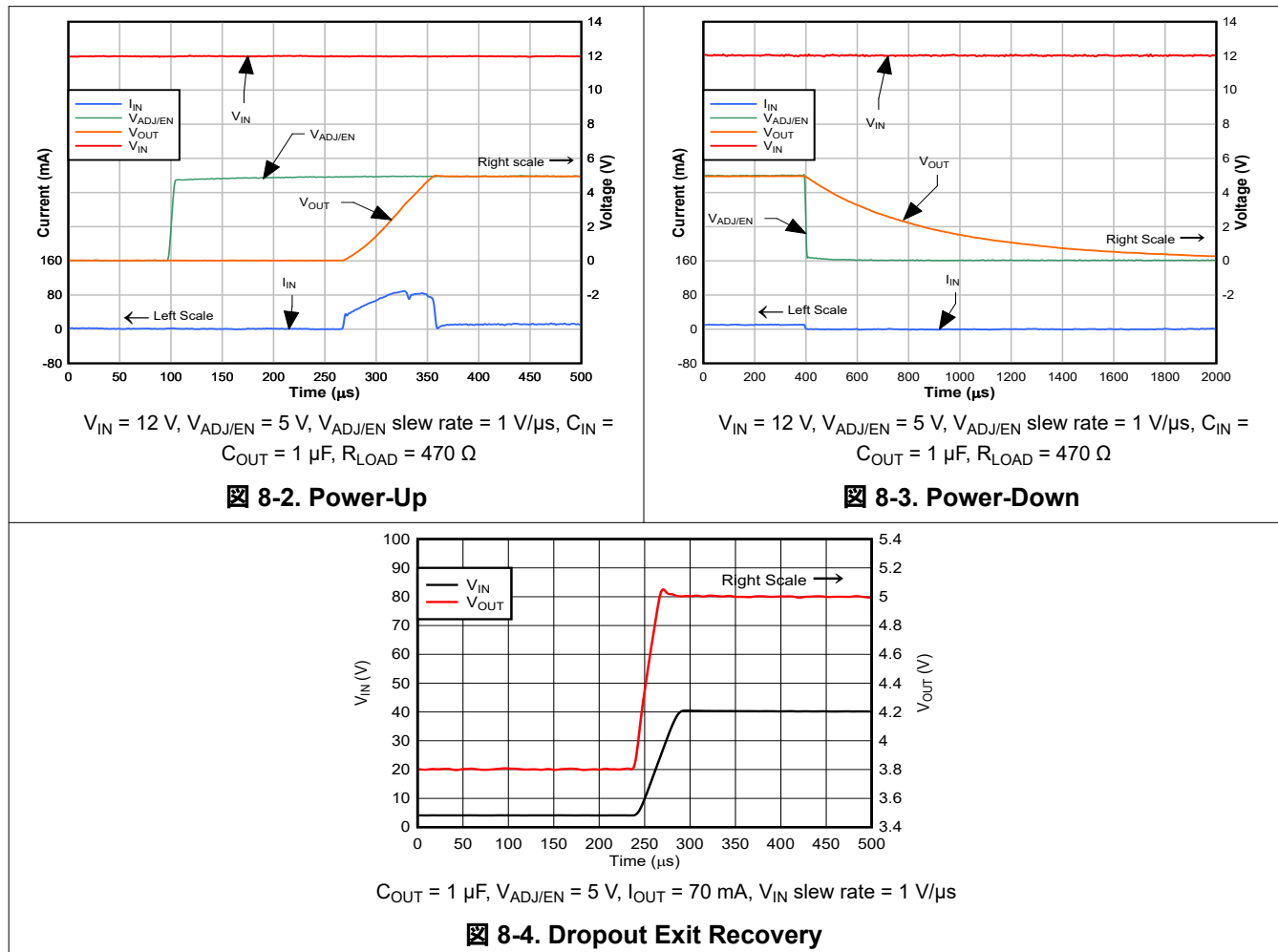
### 8.2.2.1 Input and Output Capacitor Selection

Depending on the end application, different values of external components can be used. An application can require a larger output capacitor during fast load steps to prevent a reset from occurring. Use a low ESR ceramic capacitor with a dielectric of type X5R or X7R for better load transient response.

The TPS7B4255-Q1 requires an output capacitor of at least 1  $\mu\text{F}$  (500 nF or larger capacitance) for stability and an equivalent series resistance (ESR) between 0.001  $\Omega$  and 3  $\Omega$ . Without the output capacitor, the regulator oscillates. For best transient performance, use X5R- and X7R-type ceramic capacitors because these capacitors have minimal variation in value and ESR over temperature. When choosing a capacitor for a specific application, be mindful of the DC bias characteristics for the capacitor. Higher output voltages cause a significant derating of the capacitor. For best performance, the maximum recommended output capacitor is 200  $\mu\text{F}$ .

Although an input capacitor is not required for stability, good analog design practice is to connect a capacitor from IN to GND, connected close to the device pins. Some input supplies have a high impedance; thus, placing the input capacitor on the input supply helps reduce the input impedance. This capacitor counteracts reactive input sources and improves transient response, input ripple, and PSRR. If the input supply has a high impedance over a large range of frequencies, several input capacitors can be used in parallel to lower the impedance over frequency. Use a higher-value capacitor if large, fast rise-time load transients are anticipated, or if the device is located several inches from the input power source.

### 8.2.3 Application Curves



## 8.3 Power Supply Recommendations

The device is designed to operate from an input voltage supply range from 3 V to 40 V.

## 8.4 Layout

### 8.4.1 Layout Guidelines

For best overall performance, place all circuit components on the same side of the circuit board and as near as practical to the respective LDO pin connections. Place ground return connections to the input and output capacitor, and to the LDO ground pin as close as possible to each other, connected by a wide, component-side, copper surface. Using vias and long traces to the input and output capacitors is strongly discouraged and negatively affects system performance. Use a ground reference plane either embedded in the PCB or located on the bottom side of the PCB opposite the components. This reference plane serves to provide accuracy of the output voltage, shield noise, and behaves similarly to a thermal plane to spread (or sink) heat from the LDO device when connected to the thermal pad. In most applications, this ground plane is necessary to meet thermal requirements.

#### 8.4.1.1 Package Mounting

Solder-pad footprint recommendations for the TPS7B4255-Q1 are available at the end of this document and at [www.ti.com](http://www.ti.com).

TI's DYB package footprint can be used for both the DYB package as well as the DBV package for easy multisourcing.

#### 8.4.1.2 Board Layout Recommendations to Improve PSRR and Noise Performance

To improve AC performance (such as PSRR, output noise, and transient response), design the board with separate ground planes for  $V_{IN}$  and  $V_{OUT}$ , with each ground plane connected only at the GND pin of the device. In addition, the ground connection for the output capacitor must connect directly to the GND pin of the device.

Equivalent series inductance (ESL) and ESR must be minimized in order to maximize performance and ensure stability. Every capacitor must be placed as close as possible to the device and on the same side of the printed circuit board (PCB) as the regulator.

Do not place any of the capacitors on the opposite side of the PCB from where the regulator is installed. Using vias and long traces is strongly discouraged because of the negative impact on system performance. Vias and long traces can also cause instability.

If possible, and to make sure that the maximum performance is as denoted in this product data sheet, use the same layout pattern used for the TPS7B4255-Q1 evaluation board, available at [www.ti.com](http://www.ti.com).

#### 8.4.1.3 Power Dissipation and Thermal Considerations

式 4 calculates the device power dissipation.

$$P_D = I_{OUT} \times (V_{IN} - V_{OUT}) + I_Q \times V_{IN} \quad (4)$$

where:

- $P_D$  = Continuous power dissipation
- $I_{OUT}$  = Output current
- $V_{IN}$  = Input voltage
- $V_{OUT}$  = Output voltage
- $I_Q$  = Quiescent current

Because  $I_Q$  is much less than  $I_{OUT}$ , the term  $I_Q \times V_{IN}$  in 式 4 can be ignored.

Calculate the junction temperature ( $T_J$ ) with 式 5 for a device under operation at a given ambient air temperature ( $T_A$ ).

$$T_J = T_A + (R_{\theta JA} \times P_D) \quad (5)$$

where:

- $R_{\theta JA}$  = Junction-to-junction-ambient air thermal impedance

式 6 calculates a rise in junction temperature because of power dissipation.

$$\Delta T = T_J - T_A = (R_{\theta JA} \times P_D) \quad (6)$$

The maximum ambient air temperature ( $T_{AMAX}$ ) at which the device can operate can be calculated with 式 7 for a given maximum junction temperature ( $T_{JMAX}$ ).

$$T_{AMAX} = T_{JMAX} - (R_{\theta JA} \times P_D) \quad (7)$$

#### 8.4.1.4 Thermal Performance Versus Copper Area

The most used thermal resistance parameter  $R_{\theta JA}$  is highly dependent on the heat-spreading capability built into the particular PCB design, and therefore varies according to the total copper area, copper weight, and location of the planes. The  $R_{\theta JA}$  recorded in the *Thermal Information* table is determined by the JEDEC standard (图 8-5), PCB, and copper-spreading area, and is only used as a relative measure of package thermal performance. For a well-designed thermal layout,  $R_{\theta JA}$  is actually the sum of the package junction-to-case (bottom) thermal resistance ( $R_{\theta JCbott}$ ) plus the thermal resistance contribution by the PCB copper.

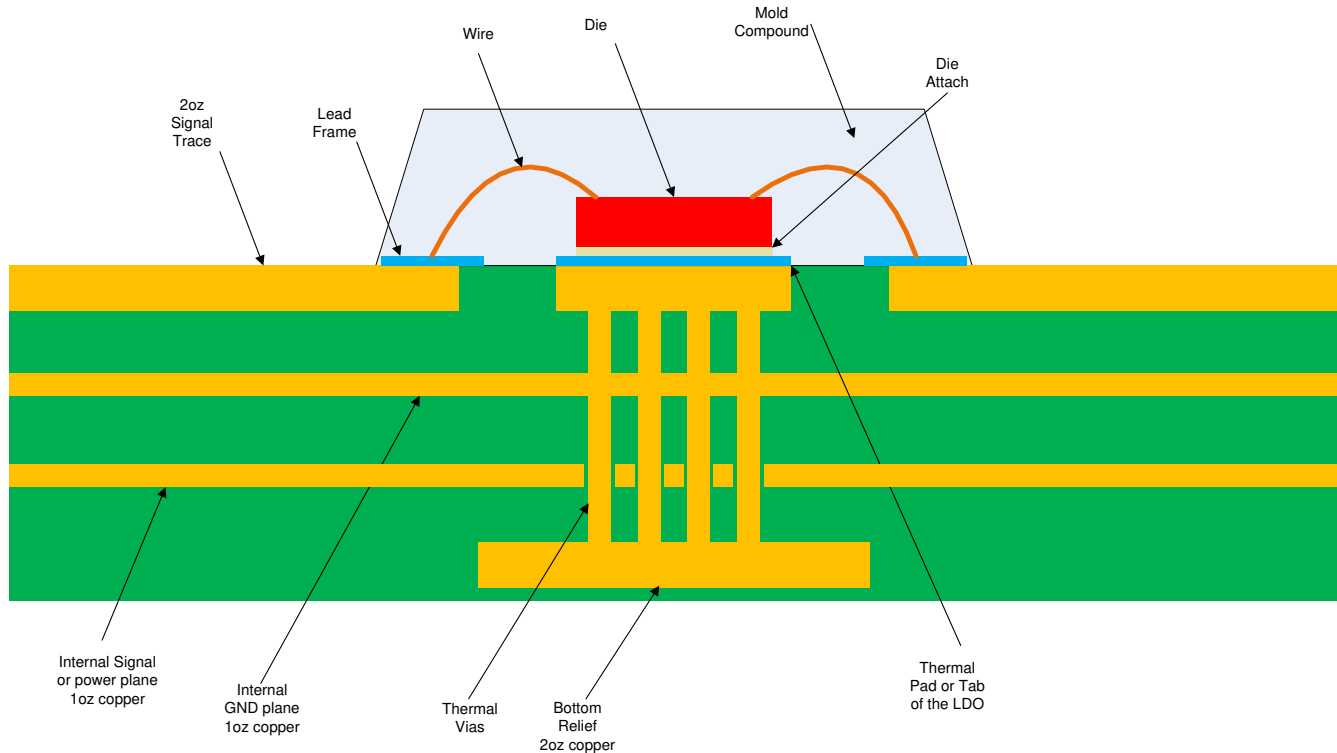
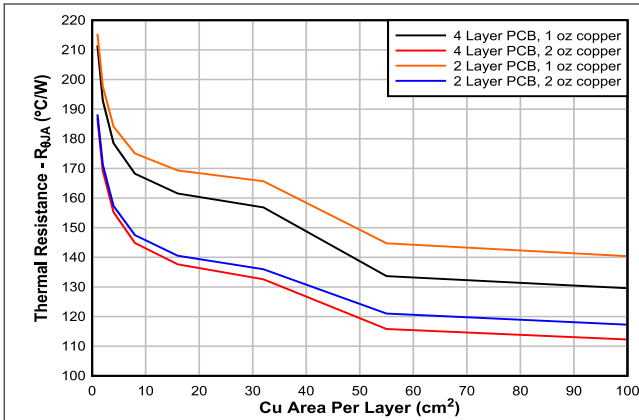


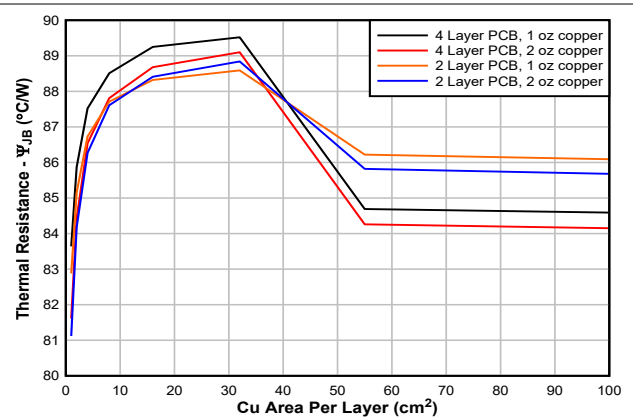
图 8-5. JEDEC Standard 2s2p PCB

图 8-6 through 图 8-9 illustrate the functions of  $R_{\theta JA}$  and  $\psi_{JB}$  versus copper area and thickness for the DBV package and DYB package. These plots are generated with a 101.6-mm × 101.6-mm × 1.6-mm PCB of two and four layers. For the 4-layer board, inner planes use 1-oz copper thickness. Outer layers are simulated with both 1-oz and 2-oz copper thickness. A 4 × 5 (DBV and DYB package) array of thermal vias with a 300-μm drill diameter and 25-μm copper plating is located as close as practical to the GND pin of the device. The thermal vias connect the top layer, the bottom layer and, in the case of the 4-layer board, the first inner GND plane. Each of the layers has a copper plane of equal area. The *PowerPAD™ Thermally Enhanced Package application note* discusses the impact that thermal vias have on thermal performance.

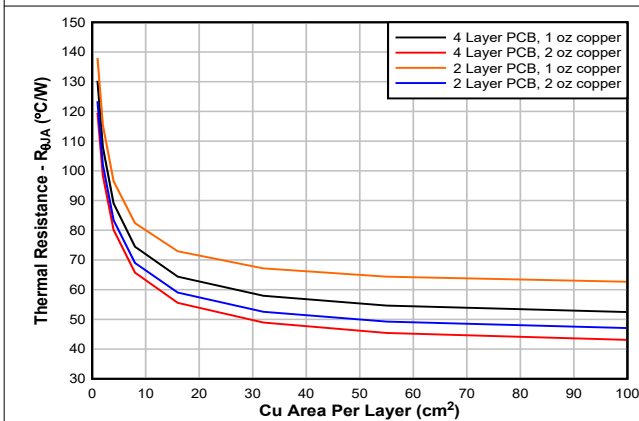
As shown in [Figure 8-7](#),  $\psi_{JB}$  increases with additional connecting copper area. The reason for this increase is that the board temperature is measured at the copper near the GND pin, and because the GND pin is fused to the die pad, more heat escapes through the GND pin when more copper is connected to the pad, and thus the temperature at this point is higher. Consequently the  $\psi_{JB}$  increases. This increase does not imply that heat sinking for the device is reduced when more connecting copper is added. Increasing connecting copper area always increases board-level heat sinking for the device. Furthermore, the boards used for [Figure 8-7](#) have vias connecting to internal copper planes. Therefore,  $\psi_{JB}$  is much higher than what is specified in the *Thermal Information* table, which uses the high-K board layout specified in JESD51-7 that has no thermal vias.



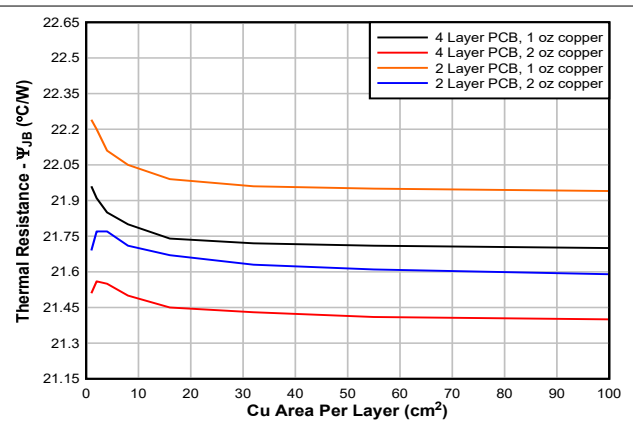
**Figure 8-6.  $R_{\theta JA}$  vs Copper Area (DBV Package)**



**Figure 8-7.  $\psi_{JB}$  vs Copper Area (DBV Package)**

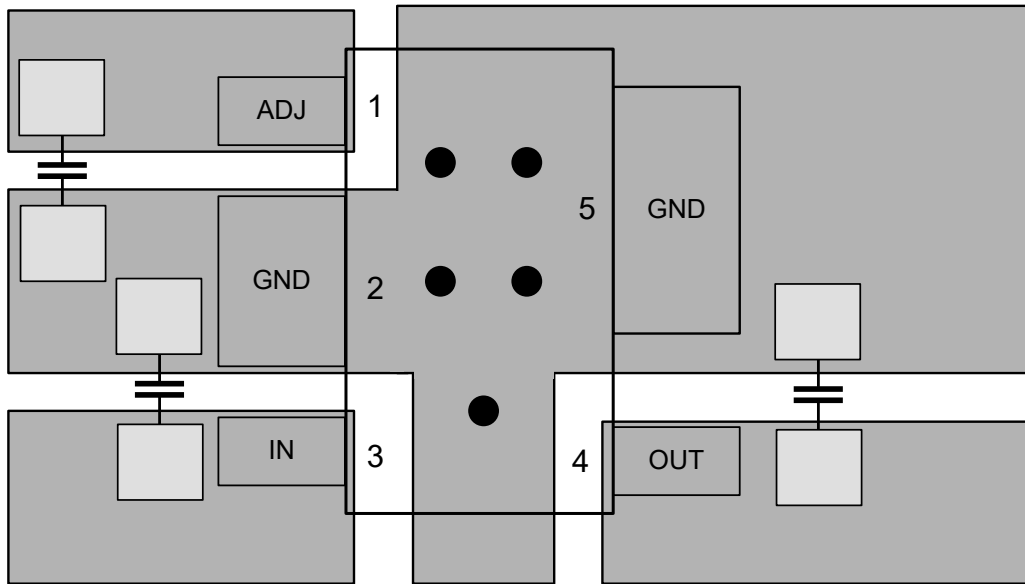


**Figure 8-8.  $R_{\theta JA}$  vs Copper Area (DYB Package)**



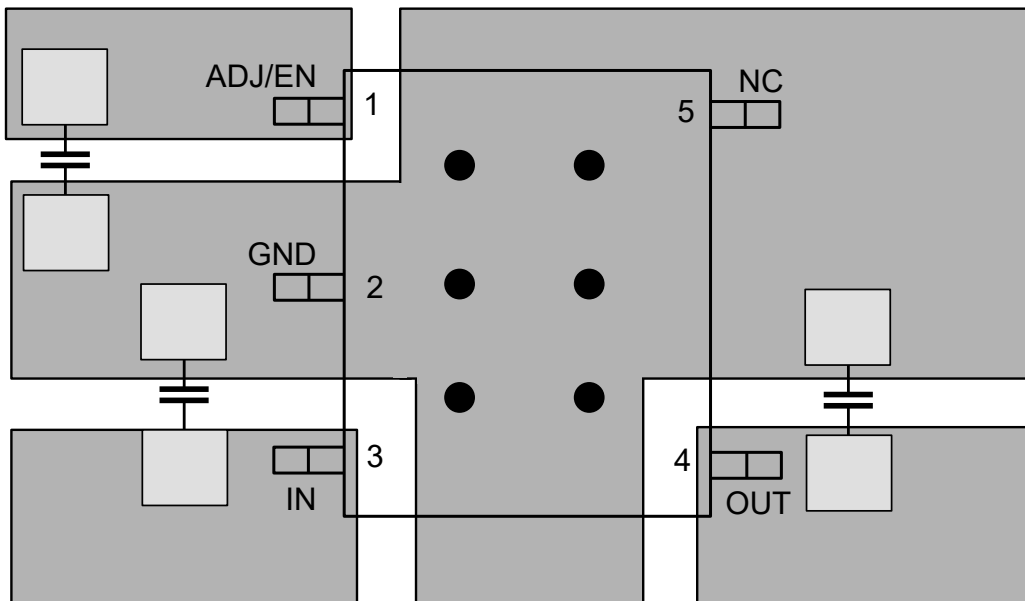
**Figure 8-9.  $\psi_{JB}$  vs Copper Area (DYB Package)**

### 8.4.2 Layout Examples



● Circles denote PCB via connections

☒ 8-10. DYB Package Layout Example



● Circles denote PCB via connections

☒ 8-11. DBV Package Layout Example

## 9 Device and Documentation Support

### 9.1 Device Support

#### 9.1.1 Device Nomenclature

表 9-1. Device Nomenclature<sup>(1)</sup>

PRODUCT	V <sub>OUT</sub>
TPS7B4255Q yyyR Q1	<p><b>Q</b> indicates that this device is a grade-1 device in accordance with the AEC-Q100 standard.</p> <p><b>yyy</b> is the package designator.</p> <p><b>R</b> is the packaging quantity.</p> <p><b>Q1</b> indicates that this device is an automotive grade (AEC-Q100) device.</p>

(1) For the most current package and ordering information see the Package Option Addendum at the end of this document, or visit the device product folder on [www.ti.com](http://www.ti.com).

### 9.2 ドキュメントの更新通知を受け取る方法

ドキュメントの更新についての通知を受け取るには、[ti.com](http://ti.com) のデバイス製品フォルダを開いてください。「更新の通知を受け取る」をクリックして登録すると、変更されたすべての製品情報に関するダイジェストを毎週受け取れます。変更の詳細については、修正されたドキュメントに含まれている改訂履歴をご覧ください。

### 9.3 サポート・リソース

**TI E2E™ サポート・フォーラム**は、エンジニアが検証済みの回答と設計に関するヒントをエキスパートから迅速かつ直接得ることができる場所です。既存の回答を検索したり、独自の質問をしたりすることで、設計に必要な支援を迅速に得ることができます。

リンクされているコンテンツは、該当する貢献者により、現状のまま提供されるものです。これらは TI の仕様を構成するものではなく、必ずしも TI の見解を反映したものではありません。TI の [使用条件](#) を参照してください。

### 9.4 Trademarks

TI E2E™ is a trademark of Texas Instruments.

すべての商標は、それぞれの所有者に帰属します。

### 9.5 静電気放電に関する注意事項



この IC は、ESD によって破損する可能性があります。テキサス・インスツルメンツは、IC を取り扱う際には常に適切な注意を払うことを推奨します。正しい取り扱いおよび設置手順に従わない場合、デバイスを破損するおそれがあります。

ESD による破損は、わずかな性能低下からデバイスの完全な故障まで多岐にわたります。精密な IC の場合、パラメータがわずかに変化するだけで公表されている仕様から外れる可能性があるため、破損が発生しやすくなっています。

### 9.6 用語集

[テキサス・インスツルメンツ用語集](#) この用語集には、用語や略語の一覧および定義が記載されています。

## 10 Mechanical, Packaging, and Orderable Information

The following pages include mechanical, packaging, and orderable information. This information is the most current data available for the designated devices. This data is subject to change without notice and revision of this document. For browser-based versions of this data sheet, refer to the left-hand navigation.

10.1 Mechanical Data

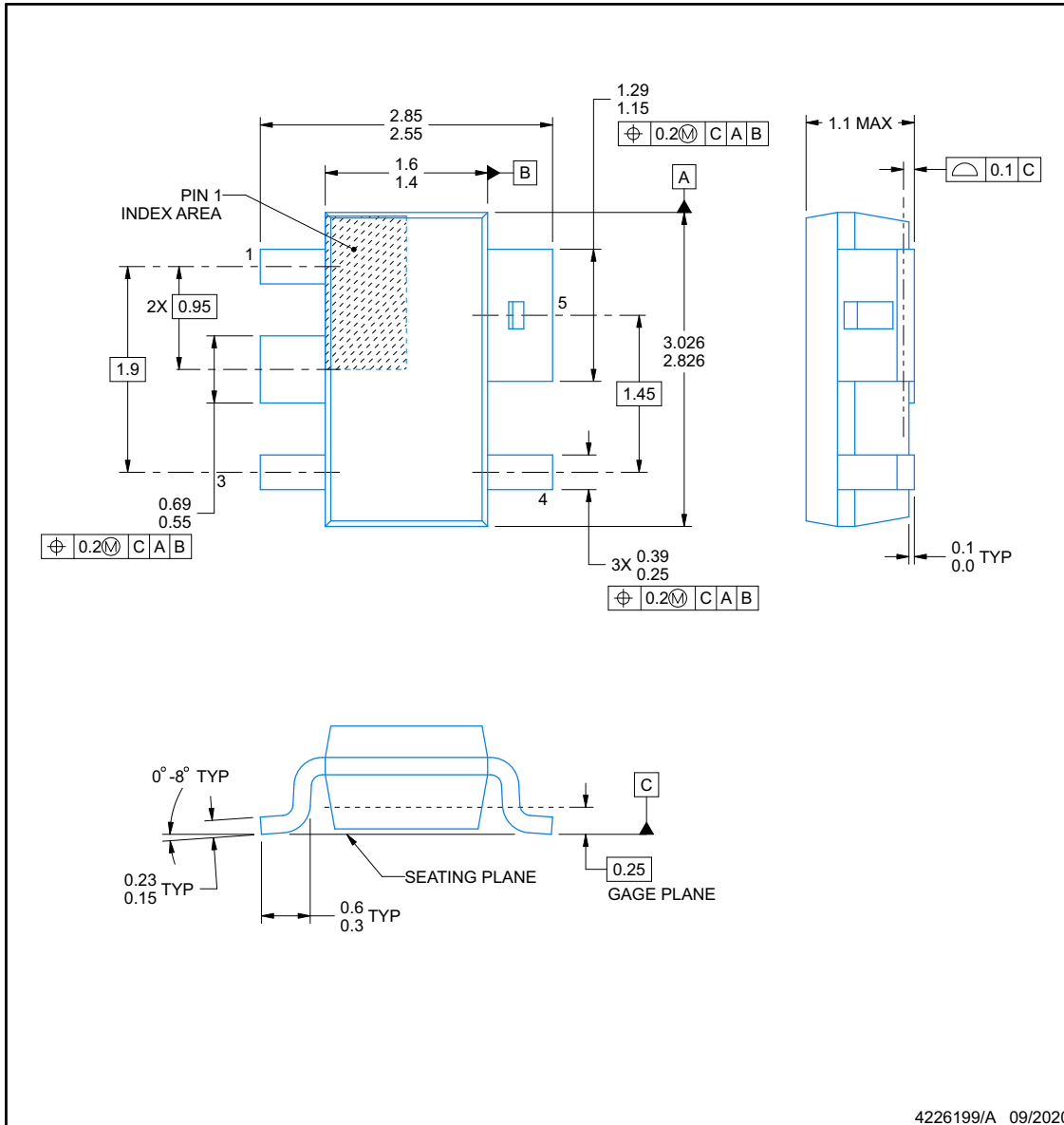


**PACKAGE OUTLINE**

**DYB0005A**

**SOT - 1.1 max height**

SOT



NOTES:

1. All linear dimensions are in millimeters. Any dimensions in parenthesis are for reference only. Dimensioning and tolerancing per ASME Y14.5M.
2. This drawing is subject to change without notice.
3. No JEDEC reference as of August 2020.

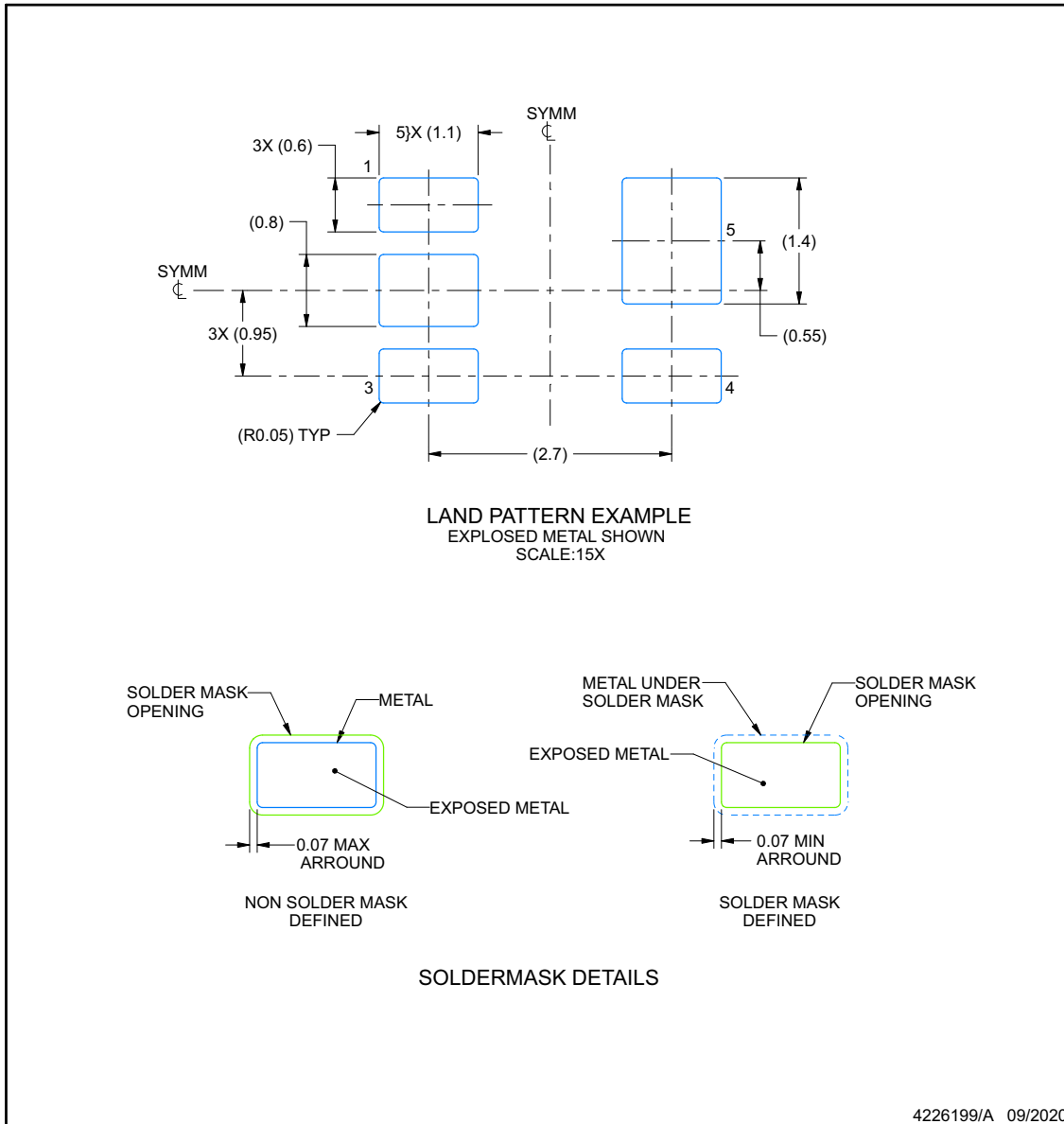


## EXAMPLE BOARD LAYOUT

**DYB0005A**

**SOT - 1.1 max height**

SOT



NOTES: (continued)

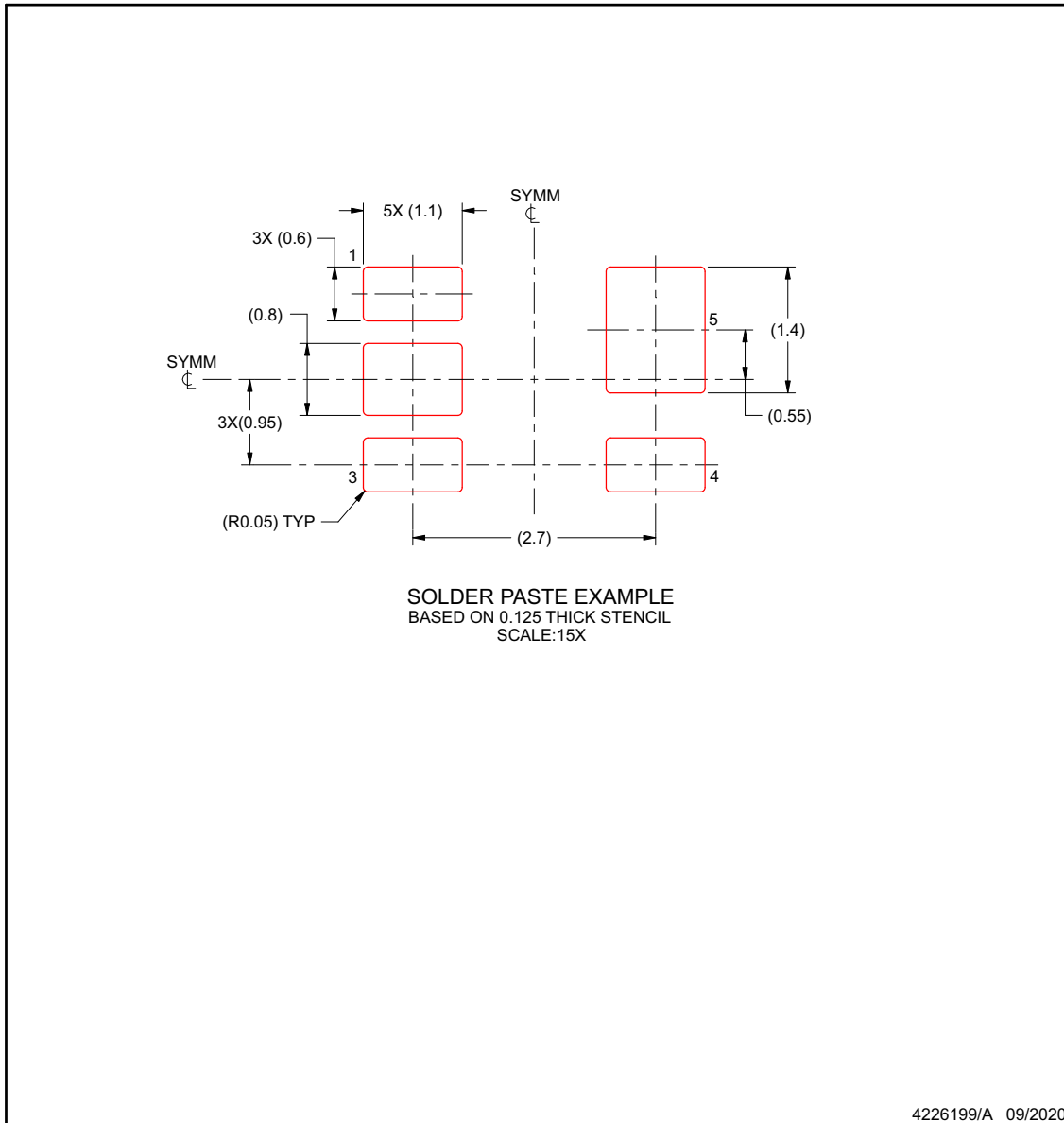
4. Publication IPC-7351 may have alternate designs.
5. Solder mask tolerances between and around signal pads can vary based on board fabrication site.

**EXAMPLE STENCIL DESIGN**

**DYB0005A**

**SOT - 1.1 max height**

SOT



NOTES: (continued)

- 6. Laser cutting apertures with trapezoidal walls and rounded corners may offer better paste release. IPC-7525 may have alternate design recommendations.
- 7. Board assembly site may have different recommendations for stencil design.

**PACKAGING INFORMATION**

Orderable Device	Status (1)	Package Type	Package Drawing	Pins	Package Qty	Eco Plan (2)	Lead finish/ Ball material (6)	MSL Peak Temp (3)	Op Temp (°C)	Device Marking (4/5)	Samples
TPS7B4255QDBVRQ1	ACTIVE	SOT-23	DBV	5	3000	RoHS & Green	NIPDAU	Level-2-260C-1 YEAR	-40 to 125	2Q5F	<a href="#">Samples</a>
TPS7B4255QDYBRQ1	ACTIVE	SOT-23	DYB	5	3000	RoHS & Green	NIPDAU	Level-1-260C-UNLIM	-40 to 125	2Q6T	<a href="#">Samples</a>

(1) The marketing status values are defined as follows:

**ACTIVE:** Product device recommended for new designs.

**LIFEBUY:** TI has announced that the device will be discontinued, and a lifetime-buy period is in effect.

**NRND:** Not recommended for new designs. Device is in production to support existing customers, but TI does not recommend using this part in a new design.

**PREVIEW:** Device has been announced but is not in production. Samples may or may not be available.

**OBSOLETE:** TI has discontinued the production of the device.

(2) **RoHS:** TI defines "RoHS" to mean semiconductor products that are compliant with the current EU RoHS requirements for all 10 RoHS substances, including the requirement that RoHS substance do not exceed 0.1% by weight in homogeneous materials. Where designed to be soldered at high temperatures, "RoHS" products are suitable for use in specified lead-free processes. TI may reference these types of products as "Pb-Free".

**RoHS Exempt:** TI defines "RoHS Exempt" to mean products that contain lead but are compliant with EU RoHS pursuant to a specific EU RoHS exemption.

**Green:** TI defines "Green" to mean the content of Chlorine (Cl) and Bromine (Br) based flame retardants meet JS709B low halogen requirements of <=1000ppm threshold. Antimony trioxide based flame retardants must also meet the <=1000ppm threshold requirement.

(3) MSL, Peak Temp. - The Moisture Sensitivity Level rating according to the JEDEC industry standard classifications, and peak solder temperature.

(4) There may be additional marking, which relates to the logo, the lot trace code information, or the environmental category on the device.

(5) Multiple Device Markings will be inside parentheses. Only one Device Marking contained in parentheses and separated by a "~" will appear on a device. If a line is indented then it is a continuation of the previous line and the two combined represent the entire Device Marking for that device.

(6) Lead finish/Ball material - Orderable Devices may have multiple material finish options. Finish options are separated by a vertical ruled line. Lead finish/Ball material values may wrap to two lines if the finish value exceeds the maximum column width.

**Important Information and Disclaimer:**The information provided on this page represents TI's knowledge and belief as of the date that it is provided. TI bases its knowledge and belief on information provided by third parties, and makes no representation or warranty as to the accuracy of such information. Efforts are underway to better integrate information from third parties. TI has taken and continues to take reasonable steps to provide representative and accurate information but may not have conducted destructive testing or chemical analysis on incoming materials and chemicals. TI and TI suppliers consider certain information to be proprietary, and thus CAS numbers and other limited information may not be available for release.

In no event shall TI's liability arising out of such information exceed the total purchase price of the TI part(s) at issue in this document sold by TI to Customer on an annual basis.

**OTHER QUALIFIED VERSIONS OF TPS7B4255-Q1 :**

- Catalog : [TPS7B4255](#)

## NOTE: Qualified Version Definitions:

- Catalog - TI's standard catalog product

**TAPE AND REEL INFORMATION**

**QUADRANT ASSIGNMENTS FOR PIN 1 ORIENTATION IN TAPE**

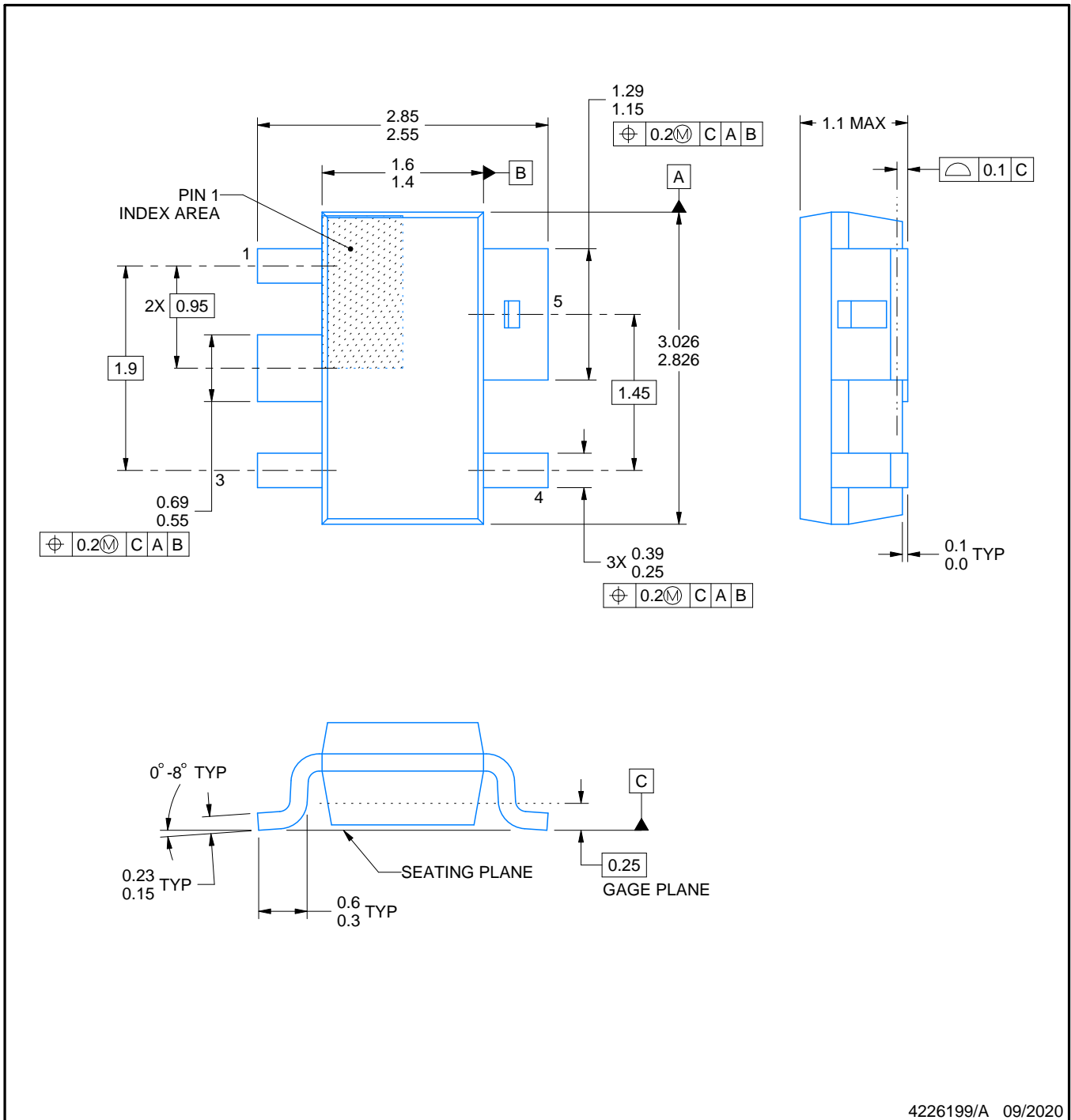

\*All dimensions are nominal

Device	Package Type	Package Drawing	Pins	SPQ	Reel Diameter (mm)	Reel Width W1 (mm)	A0 (mm)	B0 (mm)	K0 (mm)	P1 (mm)	W (mm)	Pin1 Quadrant
TPS7B4255QDBVRQ1	SOT-23	DBV	5	3000	180.0	8.4	3.2	3.2	1.4	4.0	8.0	Q3
TPS7B4255QDYBRQ1	SOT-23	DYB	5	3000	178.0	9.0	3.2	3.05	1.2	4.0	8.0	Q2

**TAPE AND REEL BOX DIMENSIONS**


\*All dimensions are nominal

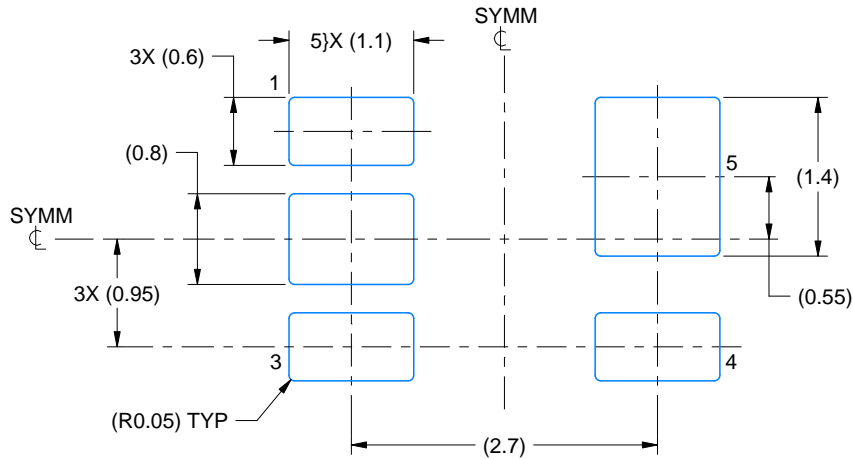
Device	Package Type	Package Drawing	Pins	SPQ	Length (mm)	Width (mm)	Height (mm)
TPS7B4255QDBVRQ1	SOT-23	DBV	5	3000	210.0	185.0	35.0
TPS7B4255QDYBRQ1	SOT-23	DYB	5	3000	180.0	180.0	18.0



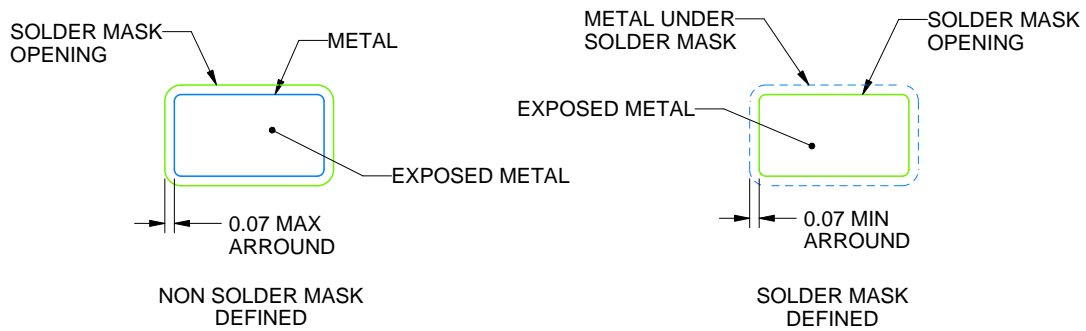
4226199/A 09/2020

NOTES:

1. All linear dimensions are in millimeters. Any dimensions in parenthesis are for reference only. Dimensioning and tolerancing per ASME Y14.5M.
2. This drawing is subject to change without notice.
3. No JEDEC reference as of August 2020.



LAND PATTERN EXAMPLE  
EXPLODED METAL SHOWN  
SCALE:15X



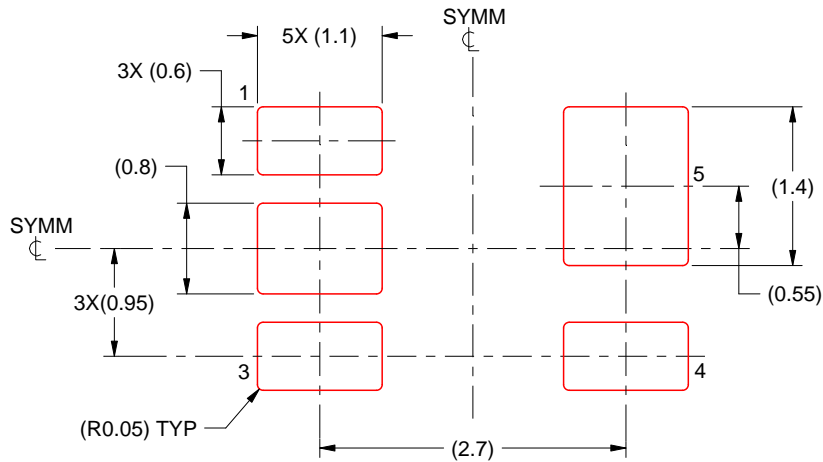
SOLDEMASK DETAILS

4226199/A 09/2020

NOTES: (continued)

- 4. Publication IPC-7351 may have alternate designs.
- 5. Solder mask tolerances between and around signal pads can vary based on board fabrication site.





SOLDER PASTE EXAMPLE  
BASED ON 0.125 THICK STENCIL  
SCALE:15X

4226199/A 09/2020

NOTES: (continued)

6. Laser cutting apertures with trapezoidal walls and rounded corners may offer better paste release. IPC-7525 may have alternate design recommendations.
7. Board assembly site may have different recommendations for stencil design.



# EXAMPLE BOARD LAYOUT

DBV0005A

SOT-23 - 1.45 mm max height

SMALL OUTLINE TRANSISTOR



LAND PATTERN EXAMPLE  
EXPOSED METAL SHOWN  
SCALE:15X



SOLDER MASK DETAILS

4214839/K 08/2024

NOTES: (continued)

- 6. Publication IPC-7351 may have alternate designs.
- 7. Solder mask tolerances between and around signal pads can vary based on board fabrication site.

# EXAMPLE STENCIL DESIGN

DBV0005A

SOT-23 - 1.45 mm max height

SMALL OUTLINE TRANSISTOR



SOLDER PASTE EXAMPLE  
BASED ON 0.125 mm THICK STENCIL  
SCALE:15X

4214839/K 08/2024

NOTES: (continued)

8. Laser cutting apertures with trapezoidal walls and rounded corners may offer better paste release. IPC-7525 may have alternate design recommendations.
9. Board assembly site may have different recommendations for stencil design.

## 重要なお知らせと免責事項

TI は、技術データと信頼性データ（データシートを含みます）、設計リソース（リファレンス・デザインを含みます）、アプリケーションや設計に関する各種アドバイス、Web ツール、安全性情報、その他のリソースを、欠陥が存在する可能性のある「現状のまま」提供しており、商品性および特定目的に対する適合性の黙示保証、第三者の知的財産権の非侵害保証を含むいかなる保証も、明示的または黙示的にかかわらず拒否します。

これらのリソースは、TI 製品を使用する設計の経験を積んだ開発者への提供を意図したものです。(1) お客様のアプリケーションに適した TI 製品の選定、(2) お客様のアプリケーションの設計、検証、試験、(3) お客様のアプリケーションに該当する各種規格や、その他のあらゆる安全性、セキュリティ、規制、または他の要件への確実な適合に関する責任を、お客様のみが単独で負うものとし、

上記の各種リソースは、予告なく変更される可能性があります。これらのリソースは、リソースで説明されている TI 製品を使用するアプリケーションの開発の目的でのみ、TI はその使用をお客様に許諾します。これらのリソースに関して、他の目的で複製することや掲載することは禁止されています。TI や第三者の知的財産権のライセンスが付与されている訳ではありません。お客様は、これらのリソースを自身で使用した結果発生するあらゆる申し立て、損害、費用、損失、責任について、TI およびその代理人を完全に補償するものとし、TI は一切の責任を拒否します。

TI の製品は、[TI の販売条件](#)、または [ti.com](#) やかかる TI 製品の関連資料などのいずれかを通じて提供する適用可能な条項の下で提供されています。TI がこれらのリソースを提供することは、適用される TI の保証または他の保証の放棄の拡大や変更を意味するものではありません。

お客様がいかなる追加条項または代替条項を提案した場合でも、TI はそれらに異議を唱え、拒否します。

郵送先住所：Texas Instruments, Post Office Box 655303, Dallas, Texas 75265  
Copyright © 2024, Texas Instruments Incorporated