

TPS92360 38V 1.2A シングル・チャンネル LED バックライト・ドライバ

1 特長

- 2.7V~5.5V の入力電圧
- 40V、1.8A の MOSFET を内蔵
- 最大 38V の LED ストリングを駆動
- スイッチ電流制限: 1.2A (最小値)
- スイッチング周波数: 1.2MHz
- 基準電圧: 204mV
- 内部補償
- PWM 輝度制御
- LED 断線保護
- 低電圧保護
- ソフト・スタート機能内蔵
- サーマル・シャットダウン
- 最大 90% の効率

2 アプリケーション

- スマートフォンのバックライト
- タブレットのバックライト
- PDA、ハンドヘルド・コンピュータ、GPS レシーバ
- 携帯用メディア・プレーヤ、携帯用 TV
- 小型ディスプレイ用の白色 LED バックライト
- ハンドヘルド・データ端末 (EPOS)
- 携帯用医療機器
- サーモスタット・ディスプレイ
- 血糖値計
- フラッシュライト
- 冷蔵庫、オープン

3 概要

定格 40V のスイッチ FET を内蔵した TPS92360 は、直列 LED を駆動する昇圧コンバータです。この昇圧コンバータは 40V、1.8A の MOSFET を内蔵しており、最小 1.2A の電流制限機能を備えています。そのため、小型から大型までのパネルのバックライトに適したシングルまたは並列 LED ストリングを駆動できます。デフォルトの白色 LED 電流は外付けのセンサ抵抗 R_{SET} により設定され、フィードバック電圧は以下の概略回路図に示すように 204mV にレギュレートされます。LED 電流は、動作時に CTRL ピンに印加されるパルス幅変調 (PWM) 信号を使うことで制御でき、これによりデューティ・サイクルが変化し、帰還基準電圧が決定されます。TPS92360 は LED 電流をバーストで供給しないため、出力コンデンサで可聴ノイズは発生しません。最大限の保護を可能にするため、デバイスには LED 断線保護機能が内蔵されています。この機能は、LED 断線条件が発生したときに TPS92360 をディセーブルにし、出力電圧がデバイスの絶対最大定格を超えないようにします。

TPS92360 は、省スペースの 5 ピン SC70 パッケージで供給されます。

製品情報(1)

部品番号	パッケージ	本体サイズ (公称)
TPS92360	SOT (5)	2.00mm × 1.25mm

(1) 利用可能なすべてのパッケージについては、このデータシートの末尾にある注文情報を参照してください。

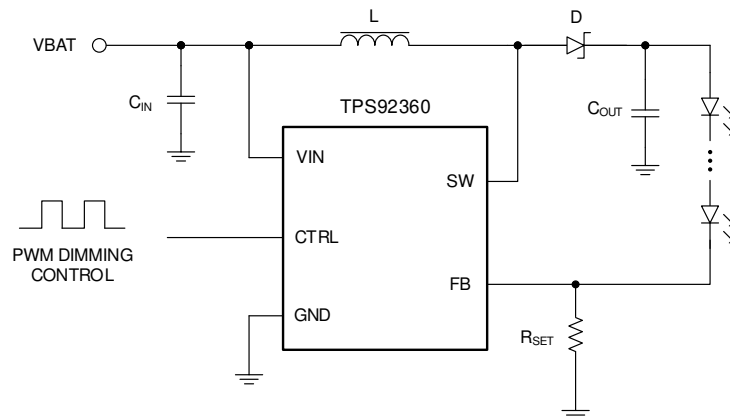

概略回路図



Table of Contents

1 特長	1	8 Application and Implementation	11
2 アプリケーション	1	8.1 Application Information.....	11
3 概要	1	8.2 Typical Application.....	11
4 Revision History	2	9 Power Supply Recommendations	17
5 Pin Configuration and Functions	3	10 Layout	17
6 Specifications	4	10.1 Layout Guidelines.....	17
6.1 Absolute Maximum Ratings.....	4	10.2 Layout Example.....	17
6.2 ESD Ratings.....	4	11 Device and Documentation Support	18
6.3 Recommended Operating Conditions.....	4	11.1 Device Support.....	18
6.4 Thermal Information.....	4	11.2 ドキュメントの更新通知を受け取る方法.....	18
6.5 Electrical Characteristics.....	5	11.3 サポート・リソース.....	18
6.6 Typical Characteristics.....	6	11.4 Trademarks.....	18
7 Detailed Description	7	11.5 静電気放電に関する注意事項.....	18
7.1 Overview.....	7	11.6 用語集.....	18
7.2 Functional Block Diagram.....	8	12 Mechanical, Packaging, and Orderable Information	18
7.3 Feature Description.....	8		
7.4 Device Functional Modes.....	10		

4 Revision History

資料番号末尾の英字は改訂を表しています。その改訂履歴は英語版に準じています。

DATE	REVISION	NOTES
March 2021	*	Initial Release

5 Pin Configuration and Functions



図 5-1. DCK Package 5-Pin SC70 (Top View)

表 5-1. Pin Functions

PIN		I/O	DESCRIPTION
NUMBER	NAME		
1	SW	I	Drain connection of the internal power FET.
2	GND	O	Ground.
3	FB	I	Feedback pin for current. Connect the sense resistor from FB to GND.
4	CTRL	I	PWM dimming signal input.
5	VIN	I	Supply input pin.

6 Specifications

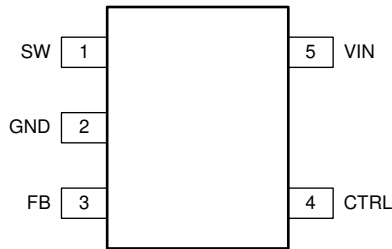
6.1 Absolute Maximum Ratings

over operating free-air temperature range (unless otherwise noted)⁽¹⁾

		MIN	MAX	UNIT
Voltage ⁽²⁾	VIN, CTRL, PWM, FB	-0.3	7	V
	SW	-0.3	40	
P _D	Continuous power dissipation	See Thermal Information Table		
T _J	Operating junction temperature	-40	150	°C
T _{stg}	Storage temperature	-65	150	°C

- (1) Stresses beyond those listed under *Absolute Maximum Ratings* may cause permanent damage to the device. These are stress ratings only, which do not imply functional operation of the device at these or any other conditions beyond those indicated under *Recommended Operating Conditions*. Exposure to absolute-maximum-rated conditions for extended periods may affect device reliability.
- (2) All voltage values are with respect to network ground terminal.

6.2 ESD Ratings

		VALUE	UNIT
V _(ESD)	Electrostatic discharge	Human-body model (HBM), per ANSI/ESDA/JEDEC JS-001 ⁽¹⁾	±2000
		Charged-device model (CDM), per JEDEC specification JESD22-C101 ⁽²⁾	±500

- (1) JEDEC document JEP155 states that 500-V HBM allows safe manufacturing with a standard ESD control process.
- (2) JEDEC document JEP157 states that 250-V CDM allows safe manufacturing with a standard ESD control process.

6.3 Recommended Operating Conditions

		MIN	NOM	MAX	UNIT
V _{IN}	Input voltage	2.7		5.5	V
V _{OUT}	Output voltage	V _{IN}		38	V
L	Inductor	4.7		10	μH
C _I	Input capacitor	1			μF
C _O	Output capacitor	1		10	μF
F _{PWM}	PWM dimming signal frequency	5		100	kHz
D _{PWM}	PWM dimming signal duty cycle	1%		100%	
T _J	Operating junction temperature	-40		125	°C

6.4 Thermal Information

THERMAL METRIC ⁽¹⁾		TPS92360	UNIT
		DCK (SC70)	
		5 PINS	
R _{θJA}	Junction-to-ambient thermal resistance ⁽²⁾	263.8	°C/W
R _{θJC(top)}	Junction-to-case (top) thermal resistance ⁽³⁾	76.1	°C/W
R _{θJB}	Junction-to-board thermal resistance ⁽⁴⁾	51.4	°C/W
ψ _{JT}	Junction-to-top characterization parameter ⁽⁵⁾	1.1	°C/W
ψ _{JB}	Junction-to-board characterization parameter ⁽⁶⁾	50.7	°C/W

- (1) For more information about traditional and new thermal metrics, see the *Semiconductor and IC Package Thermal Metrics* application report, [SPRA953](#).
- (2) The junction-to-ambient thermal resistance under natural convection is obtained in a simulation on a JEDEC-standard, high-K board, as specified in JESD51-7, in an environment described in JESD51-2a.
- (3) The junction-to-case (top) thermal resistance is obtained by simulating a cold plate test on the package top. No specific JEDEC-standard test exists, but a close description can be found in the ANSI SEMI standard G30-88.

- (4) The junction-to-board thermal resistance is obtained by simulating in an environment with a ring cold plate fixture to control the PCB temperature, as described in JESD51-8.
- (5) The junction-to-top characterization parameter, ψ_{JT} , estimates the junction temperature of a device in a real system and is extracted from the simulation data for obtaining $R_{\theta JA}$, using a procedure described in JESD51-2a (sections 6 and 7).
- (6) The junction-to-board characterization parameter, ψ_{JB} , estimates the junction temperature of a device in a real system and is extracted from the simulation data for obtaining $R_{\theta JA}$, using a procedure described in JESD51-2a (sections 6 and 7).

6.5 Electrical Characteristics

Over operating free-air temperature range, $V_{IN} = 3.6\text{ V}$, $CTRL = V_{IN}$ (unless otherwise specified).

PARAMETER		TEST CONDITIONS	MIN	TYP	MAX	UNIT
POWER SUPPLY						
V_{IN}	Input voltage range		2.7		5.5	V
V_{VIN_UVLO}	Undervoltage lockout threshold	V_{IN} falling V_{IN} rising		2	2.3 2.6	V
V_{VIN_HYS}	V_{IN} UVLO hysteresis			200		mV
I_{Q_VIN}	Operating quiescent current into V_{IN}	Device enable, switching 1.2 MHz and no load,		0.3	0.45	mA
I_{SD}	Shutdown current	CTRL = GND		1	2	μ A
CONTROL LOGIC AND TIMING						
V_H	CTRL Logic high voltage		1.2			V
V_L	CTRL Logic Low voltage				0.4	V
R_{PD}	CTRL pin internal pull-down resistor			300		K Ω
t_{SD}	CTRL logic low time to shutdown	CTRL high to low	2.5			ms
VOLTAGE AND CURRENT REGULATION						
V_{REF}	Voltage feedback regulation voltage	Duty = 100%, $T_A \geq 25^\circ\text{C}$	188	204	220	mV
I_{FB}	FB pin bias current	$V_{FB} = 204\text{ mV}$			2.5	μ A
t_{REF}	V_{REF} filter time constant			1		ms
POWER SWITCH						
$R_{DS(ON)}$	N-channel MOSFET on-resistance			0.35	0.7	Ω
I_{LN_NFET}	N-channel leakage current	$V_{SW} = 35\text{ V}$			1	μ A
SWITCHING FREQUENCY						
f_{SW}	Switching frequency	$V_{IN} = 3\text{ V}$	0.75	1.2	1.5	MHz
PROTECTION AND SOFT START						
I_{LIM}	Switching MOSFET current limit	$D = D_{MAX}$, $T_A \leq 85^\circ\text{C}$	1.2	1.8	2.4	A
I_{LIM_Start}	Switching MOSFET start-up current limit	$T_A \leq 85^\circ\text{C}$		0.72		A
t_{Half_LIM}	Time step for half current limit			6.5		ms
V_{OVP_SW}	Output voltage overvoltage threshold		36	37.5	39	V
THERMAL SHUTDOWN						
$T_{shutdown}$	Thermal shutdown threshold			160		$^\circ\text{C}$
T_{hys}	Thermal shutdown hysteresis			15		$^\circ\text{C}$

6.6 Typical Characteristics

At $T_A = 25^\circ\text{C}$, unless otherwise noted.

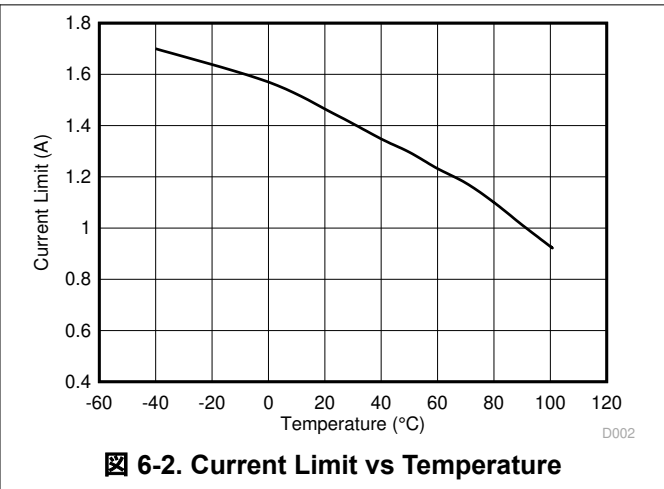
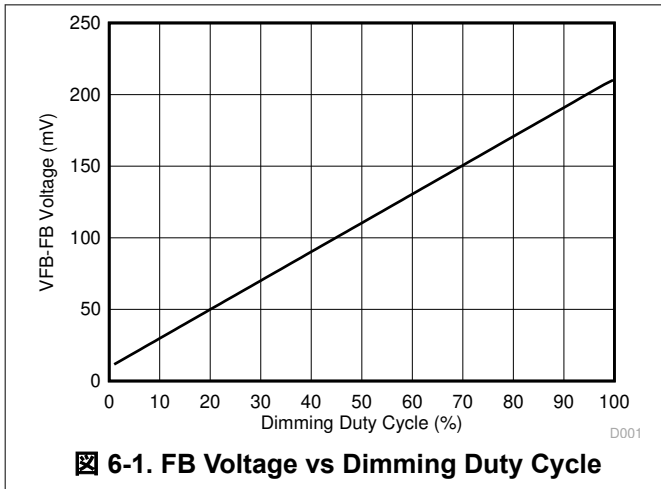

7 Detailed Description

7.1 Overview

The TPS92360 is a high-efficiency, high-output voltage boost converter in small package size. The device integrates 40-V/1.8-A switch FET and is designed for output voltage up to 39 V with a switch peak current limit of 1.2-A minimum. Its large driving capability can drive single or parallel LED strings for small to large size panel backlighting.

The TPS92360 operates in a current mode scheme with quasi-constant frequency. It is internally compensated for maximum flexibility and stability. The switching frequency is 1.2 MHz, and the minimum input voltage is 2.7 V. During the on-time, the current rises into the inductor. When the current reaches a threshold value set by the internal GM amplifier, the power switch MOSFET is turned off. The polarity of the inductor changes and forward biases the schottky diode which lets the current flow towards the output of the boost converter. The off-time is fixed for a certain V_{IN} and V_{OUT} , and therefore maintains the same frequency when varying these parameters.

However, for different output loads, the frequency slightly changes due to the voltage drop across the $R_{DS(ON)}$ of the power switch MOSFET, this has an effect on the voltage across the inductor and thus on t_{ON} (t_{OFF} remains fixed). The fixed off-time maintains a quasi-fixed frequency that provides better stability for the system over a wider range of input and output voltages than conventional boost converters. The TPS92360 topology has also the benefits of providing very good load and line regulations, and excellent line and load transient responses.

The feedback loop regulates the FB pin to a low reference voltage (204-mV typical), reducing the power dissipation in the current sense resistor.

7.2 Functional Block Diagram

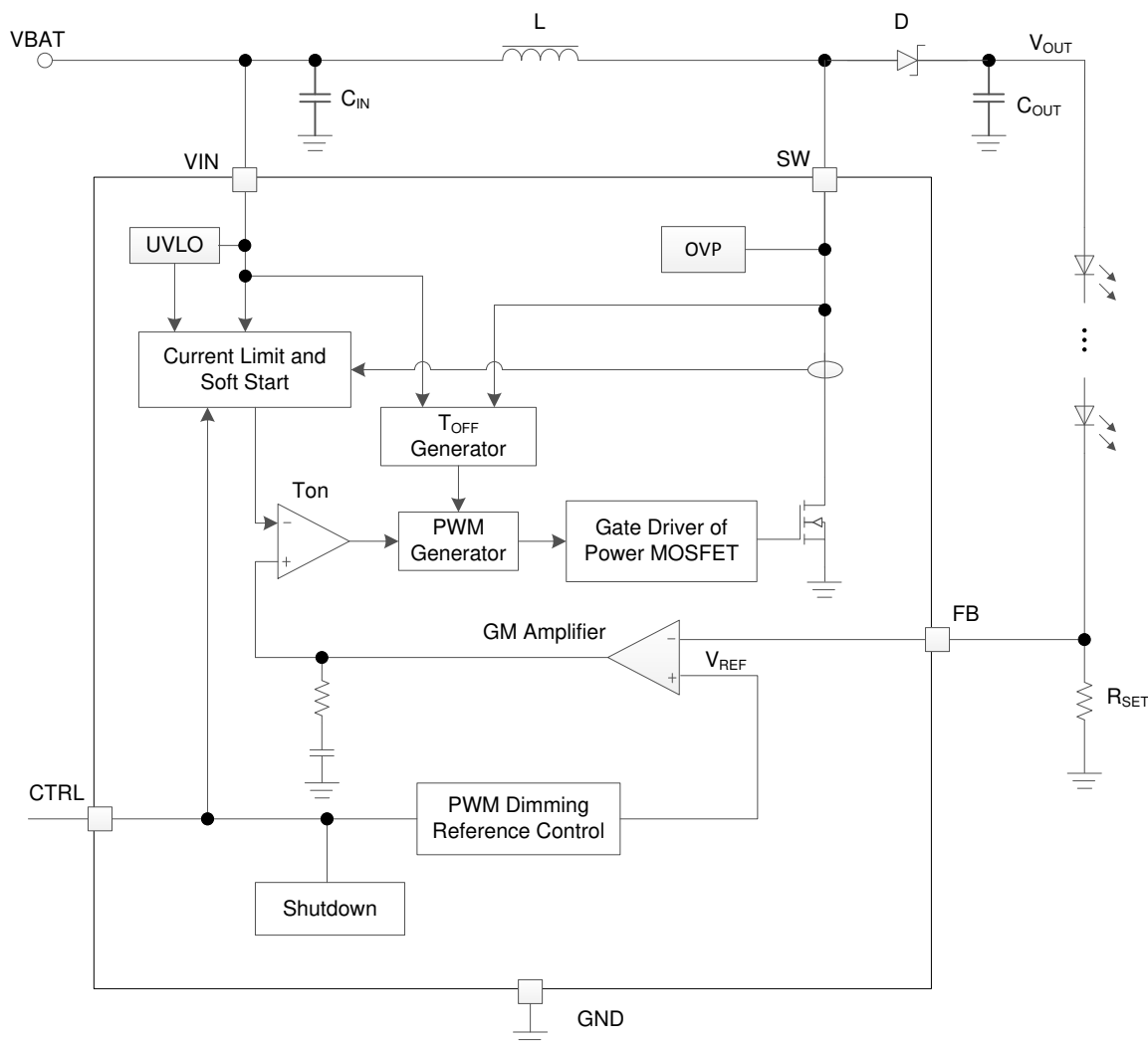

7.3 Feature Description

7.3.1 Soft Start-Up

Soft-start circuitry is integrated into the IC to avoid high inrush current spike during start-up. After the device is enabled, the GM amplifier output voltage ramps up very slowly, which ensures that the output voltage rises slowly to reduce the input current. During this period, the switch current limit is set to 0.72 A. After around 6.5 ms, the switch current limit changes back to I_{LIM} , and the FB pin voltage ramps up to the reference voltage slowly. These features ensure the smooth start-up and minimize the inrush current. See [8-9](#) for a typical example.

7.3.2 Open LED Protection

Open LED protection circuitry prevents IC damage as the result of white LED disconnection. The TPS92360 monitors the voltage at the SW pin and FB pin during each switching cycle. The circuitry turns off the switch FET and shuts down the IC when both of the following conditions persist for 3 switching cycles: (1) the SW voltage exceeds the VOVP threshold, and (2) the FB voltage is less than 30 mV. As the result, the output voltage falls to the level of the input supply. The device remains in shutdown mode until it is enabled by toggling the CTRL pin.

7.3.3 Shutdown

The TPS92360 enters shutdown mode when the CTRL voltage is logic low for more than 2.5 ms. During shutdown, the input supply current for the device is less than 2 μ A (max). Although the internal switch FET does

not switch in shutdown, there is still a DC current path between the input and the LEDs through the inductor and Schottky diode. The minimum forward voltage of the LED array must exceed the maximum input voltage to ensure that the LEDs remain off in shutdown.

7.3.4 Current Program

The FB voltage is regulated by a low 204-mV reference voltage. The LED current is programmed externally using a current-sense resistor in series with the LED string(s). The value of the R_{SET} is calculated using:

$$I_{LED} = \frac{V_{FB}}{R_{SET}} \quad (1)$$

where

- I_{LED} = total output current of LED string(s)
- V_{FB} = regulated voltage of FB pin
- R_{SET} = current sense resistor

The output current tolerance depends on the FB accuracy and the current sensor resistor accuracy.

7.3.5 LED Brightness Dimming

The TPS92360 receives PWM dimming signal at CTRL pin to control the total output current. When the CTRL pin is constantly high, the FB voltage is regulated to 204 mV typically. When the duty cycle of the input PWM signal is low, the regulation voltage at FB pin is reduced, and the total output current is reduced; therefore, it achieves LED brightness dimming. The relationship between the duty cycle and FB regulation voltage is given by:

$$V_{FB} = \text{Duty} \times 204 \text{ mV} \quad (2)$$

where

- Duty = Duty cycle of the PWM signal
- 204 mV = internal reference voltage

Thus, the user can easily control the WLED brightness by controlling the duty cycle of the PWM signal.

As shown in [Figure 7-1](#), the IC chops up the internal 204-mV reference voltage at the duty cycle of the PWM signal. The pulse signal is then filtered by an internal low-pass filter. The output of the filter is connected to the GM amplifier as the reference voltage for the FB pin regulation. Therefore, although a PWM signal is used for brightness dimming, only the WLED DC current is modulated, which is often referred as analog dimming. This eliminates the audible noise which often occurs when the LED current is pulsed in replica of the frequency and duty cycle of PWM control. Unlike other methods which filter the PWM signal for analog dimming, TPS92360 regulation voltage is independent of the PWM logic voltage level which often has large variations.

For optimum performance, use the PWM dimming frequency in the range of 5 kHz to 100 kHz. If the PWM frequency is lower than 5 kHz, it is out of the low pass filter's filter range, the FB regulation voltage ripple becomes large, causing large output ripple and may generate audible noise.

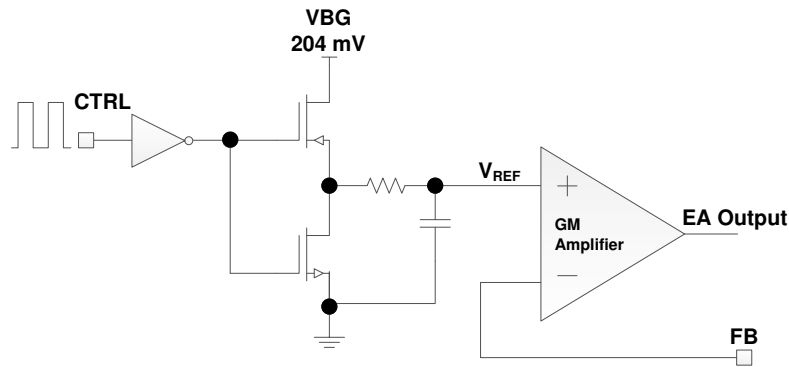

7-1. Programmable FB Voltage Using PWM Signal

7.3.6 Undervoltage Lockout

An undervoltage lockout prevents operation of the device at input voltages below typical 2 V. When the input voltage is below the undervoltage threshold, the device is shut down, and the internal switch FET is turned off. If the input voltage rises by undervoltage lockout hysteresis, the IC restarts.

7.3.7 Thermal Foldback and Thermal Shutdown

When TPS92360 drives heavy load for large size panel applications, the power dissipation increases a lot and the device junction temperature may reach a very high value, affecting the device function and reliability. In order to lower the thermal stress, the TPS92360 features a thermal foldback function. When the junction temperature is higher than 100°C, the switch current limit I_{LIM} is reduced automatically as 6-2 shows. This thermal foldback mechanism controls the power dissipation and keeps the junction temperature from rising to a very high value. If the typical junction temperature of 160°C is exceeded, an internal thermal shutdown turns off the device. The device is released from shutdown automatically when the junction temperature decreases by 15°C.

7.4 Device Functional Modes

7.4.1 Operation with CTRL

The enable rising edge threshold voltage is 1.2 V. When the CTRL pin is held below that voltage the device is disabled and switching is inhibited. The IC quiescent current is reduced in this state. When input voltage is above the UVLO threshold, and the CTRL pin voltage is increased above the rising edge threshold, the device becomes active. Switching enables and the soft-start sequence initiates.

8 Application and Implementation

注

Information in the following applications sections is not part of the TI component specification, and TI does not warrant its accuracy or completeness. TI's customers are responsible for determining suitability of components for their purposes, as well as validating and testing their design implementation to confirm system functionality.

8.1 Application Information

The TPS92360 device is a step-up DC-DC converter which can drive single or parallel LED strings for small- to large-size panel backlighting. This section includes a design procedure ([Detailed Design Procedure](#)) to select component values for the TPS92360 typical application ([Figure 8-1](#)).

8.2 Typical Application

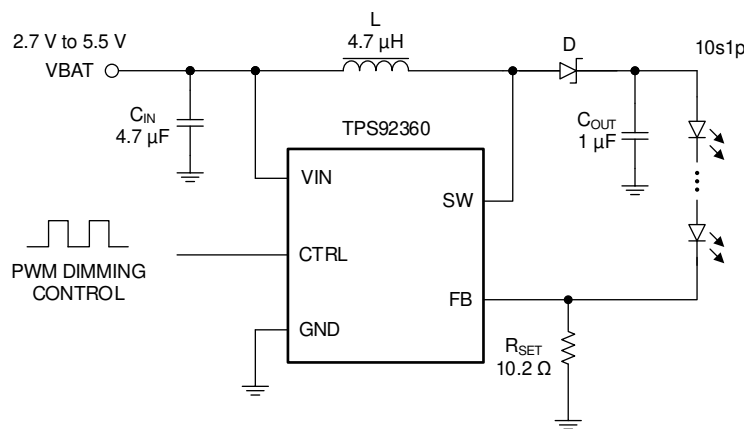

Figure 8-1. TPS92360 2.7-V to 5.5-V Input, 10 LEDs in Series Output Converter

8.2.1 Design Requirements

For this design example, use the parameters listed in [Table 8-1](#) as the input parameters.

Table 8-1. Design Parameters

DESIGN PARAMETER	EXAMPLE VALUE
Input voltage range	2.7 V to 5.5 V
Output, LED number in a string	10
Output, LED string number	1
Output, LED current per string	20 mA

8.2.2 Detailed Design Procedure

8.2.2.1 Inductor Selection

The selection of the inductor affects power efficiency, steady state operation as well as transient behavior and loop stability. These factors make it the most important component in power regulator design. There are three important inductor specifications, inductor value, DC resistance and saturation current. Considering inductor value alone is not enough. The inductor value determines the inductor ripple current. Choose an inductor that can handle the necessary peak current without saturating. Follow [Equation 3](#) to [Equation 4](#) to calculate the peak current of the inductor. To calculate the current in the worst case, use the minimum input voltage, maximum output voltage and maximum load current of application. In a boost regulator, the input DC current can be calculated as [Equation 3](#).

$$I_{L(DC)} = \frac{V_{OUT} \times I_{OUT}}{V_{IN} \times \eta} \quad (3)$$

where

- V_{OUT} = boost output voltage
- I_{OUT} = boost output current
- V_{IN} = boost input voltage
- η = power conversion efficiency

The inductor current peak to peak ripple can be calculated as 式 4.

$$\Delta I_{L(P-P)} = \frac{1}{L \times \left(\frac{1}{V_{OUT} - V_{IN}} + \frac{1}{V_{IN}} \right) \times F_S} \quad (4)$$

where

- $\Delta I_{L(P-P)}$ = inductor peak-to-peak ripple
- L = inductor value
- F_S = boost switching frequency
- V_{OUT} = boost output voltage
- V_{IN} = boost input voltage

Therefore, the peak current $I_{L(P)}$ seen by the inductor is calculated with 式 5.

$$I_{L(P)} = I_{L(DC)} + \frac{\Delta I_{L(P-P)}}{2} \quad (5)$$

Inductor values can have $\pm 20\%$ tolerance with no current bias. When the inductor current approaches saturation level, its inductance can decrease 20% to 35% from the 0-A value depending on how the inductor vendor defines saturation current. Using an inductor with a smaller inductance value forces discontinuous PWM when the inductor current ramps down to zero before the end of each switching cycle. This reduces the boost converter's maximum output current, causes large input voltage ripple and reduces efficiency. Large inductance value provides much more output current and higher conversion efficiency. For these reasons, a 4.7- μH to 10- μH inductor value range is recommended, and 4.7- μH inductor is recommended for higher than 5-V input voltage by considering inductor peak current and loop stability. 表 8-2 lists the recommended inductor for the TPS92360.

表 8-2. Recommended Inductors for TPS92360

PART NUMBER	L (μH)	DCR MAX (m Ω)	SATURATION CURRENT (A)	SIZE (L x W x H mm)	VENDOR
LPS4018-472ML	4.7	125	1.9	4 x 4 x 1.8	Coilcraft
LPS4018-103ML	10	200	1.3	4 x 4 x 1.8	Coilcraft
PCMB051H-4R7M	4.7	85	4	5.4 x 5.2 x 1.8	Cyntec
PCMB051H-100M	10	155	3	5.4 x 5.2 x 1.8	Cyntec

8.2.2.2 Schottky Diode Selection

The TPS92360 demands a low forward voltage, high-speed and low capacitance Schottky diode for optimum efficiency. Ensure that the diode average and peak current rating exceeds the average output current and peak inductor current. In addition, the diode reverse breakdown voltage must exceed the open LED protection voltage. ONsemi NSR0240 is recommended for the TPS92360.

8.2.2.3 Output Capacitor Selection

The output capacitor is mainly selected to meet the requirement for the output ripple and loop stability. This ripple voltage is related to capacitor capacitance and its equivalent series resistance (ESR). Assuming a capacitor with zero ESR, the minimum capacitance needed for a given ripple can be calculated with 式 6:

$$C_{OUT} = \frac{(V_{OUT} - V_{IN}) \times I_{OUT}}{V_{OUT} \times F_S \times V_{ripple}} \quad (6)$$

where

- V_{ripple} = peak-to-peak output ripple

The additional part of the ripple caused by ESR is calculated using: $V_{ripple_ESR} = I_{OUT} \times R_{ESR}$

Due to its low ESR, V_{ripple_ESR} could be neglected for ceramic capacitors, a 1- μ F to 4.7- μ F capacitor is recommended for typical application.

8.2.2.4 LED Current Set Resistor

The LED current set resistor can be calculated by 式 1.

8.2.2.5 Thermal Considerations

The allowable IC junction temperature must be considered under normal operating conditions. This restriction limits the power dissipation of the TPS92360. The allowable power dissipation for the device can be determined by 式 7:

$$P_D = \frac{T_J - T_A}{R_{\theta JA}} \quad (7)$$

where

- T_J is allowable junction temperature given in recommended operating conditions
- T_A is the ambient temperature for the application
- $R_{\theta JA}$ is the thermal resistance junction-to-ambient given in Power Dissipation Table

The TPS92360 device also features a thermal foldback function to reduce the thermal stress automatically.

8.2.3 Application Curves

Typical application condition is as in [Figure 8-1](#), $V_{IN} = 3.6\text{ V}$, $R_{SET} = 10.2\ \Omega$, $L = 4.7\ \mu\text{H}$, $C_{OUT} = 1\ \mu\text{F}$, 10 LEDs in series (unless otherwise specified).

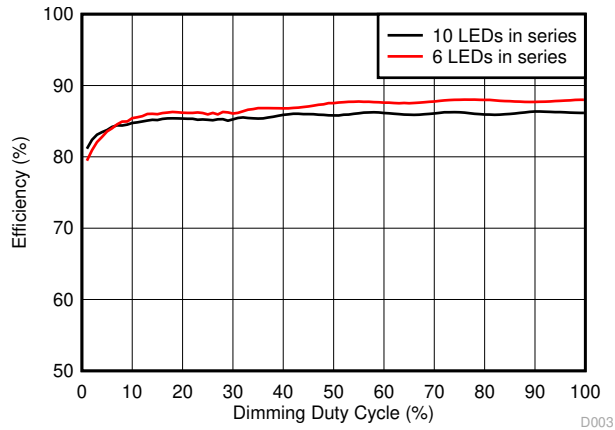

Figure 8-2. Efficiency vs Dimming Duty Cycle

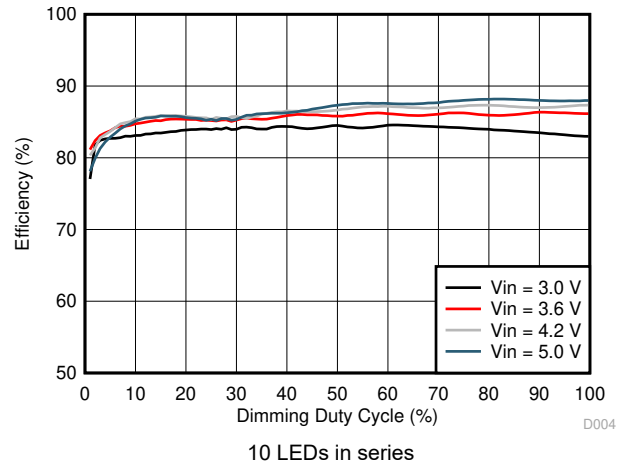

Figure 8-3. Efficiency vs Dimming Duty Cycle

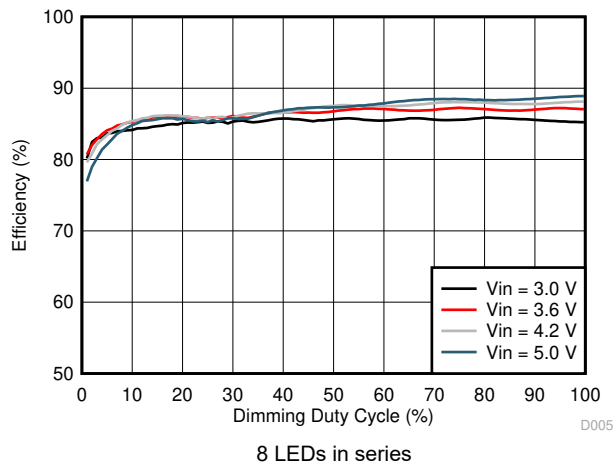

Figure 8-4. Efficiency vs Dimming Duty Cycle

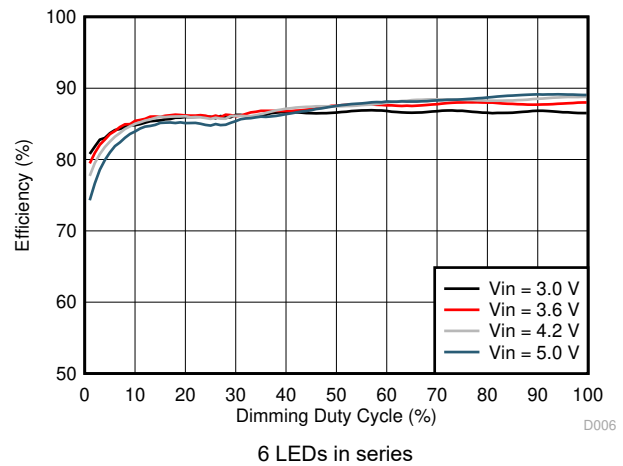

Figure 8-5. Efficiency vs Dimming Duty Cycle

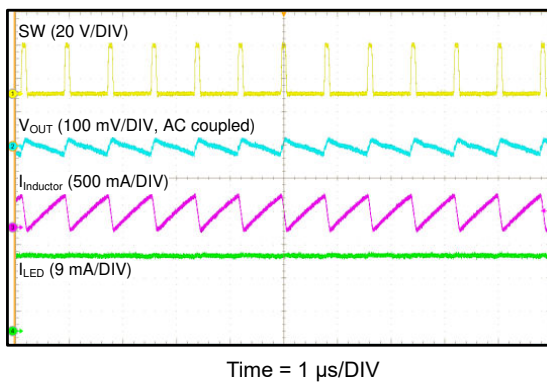

Figure 8-6. Switching-Dimming Duty = 100%

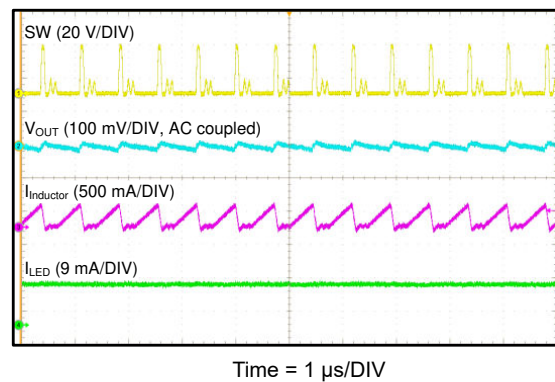
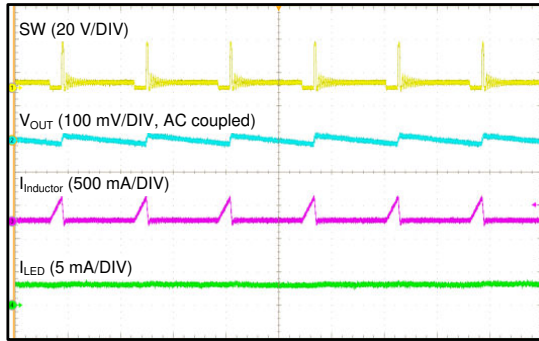
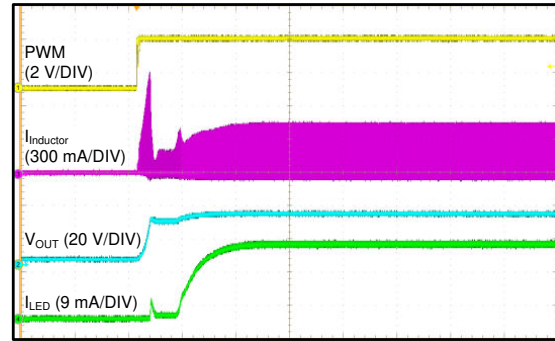

Figure 8-7. Switching-Dimming Duty = 50%



Time = 2 μ s/DIV

8-8. Switching-Dimming Duty = 10%



Time = 2 ms/DIV

8-9. Start-Up Dimming Duty = 100%

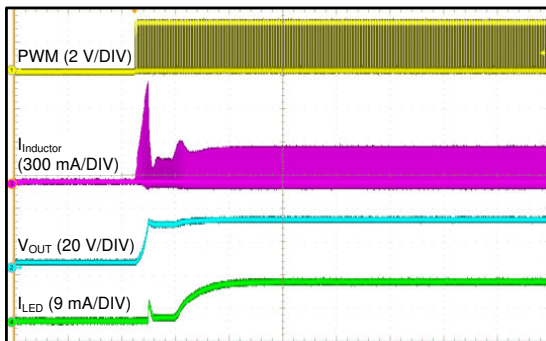

Time = 2 ms/DIV

8-10. Start-Up Dimming Duty = 50%

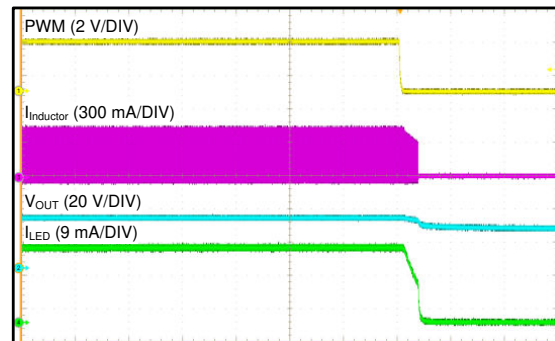

Time = 2 ms/DIV

8-11. Shutdown Dimming Duty = 100%

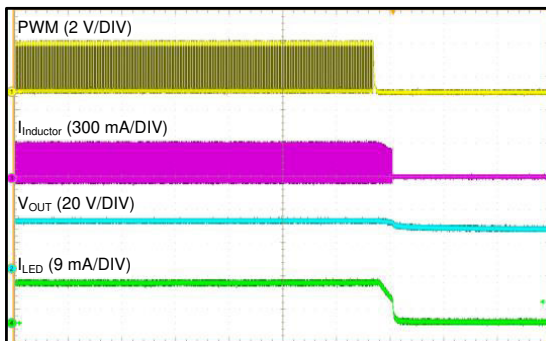

Time = 2 ms/DIV
Duty = 50%

8-12. Shutdown Dimming

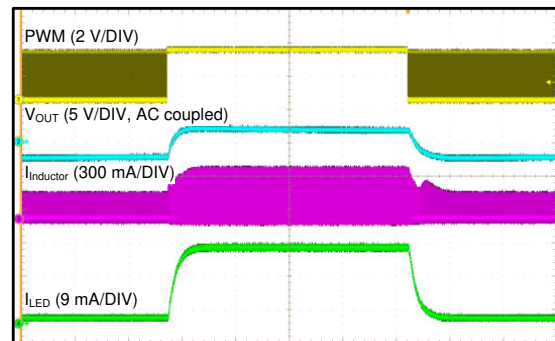

Time = 5 ms/DIV
Duty = 1%-100%-1%

8-13. Dimming Transient-Dimming

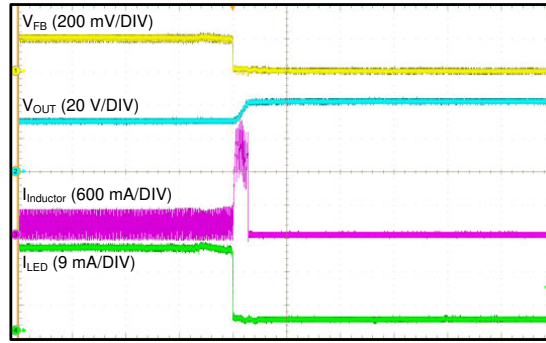

Time = 50 μ s/DIV

 8-14. Open LED Protection

9 Power Supply Recommendations

The device is designed to operate from an input voltage supply range between 2.7 V and 5.5 V. This input supply must be well regulated. If the input supply is located more than a few inches from the TPS92360 device, additional bulk capacitance may be required in addition to the ceramic bypass capacitors.

10 Layout

10.1 Layout Guidelines

As for all switching power supplies, especially those high frequency and high current ones, layout is an important design step. If layout is not carefully done, the regulator could suffer from instability as well as noise problems. Therefore, use wide and short traces for high current paths. The input capacitor C_{IN} must be close to VIN pin and GND pin in order to reduce the input ripple seen by the device. If possible, choose higher capacitance value for it. The SW pin carries high current with fast rising and falling edge; therefore, the connection between the SW pin to the inductor must be kept as short and wide as possible. The output capacitor C_{OUT} must be put close to VOUT pin. It is also beneficial to have the ground of C_{OUT} close to the GND pin because there is large ground return current flowing between them. FB resistor must be put close to FB pin. When laying out signal ground, TI recommends using short traces separated from power ground traces and connecting them together at a single point close to the GND pin.

10.2 Layout Example

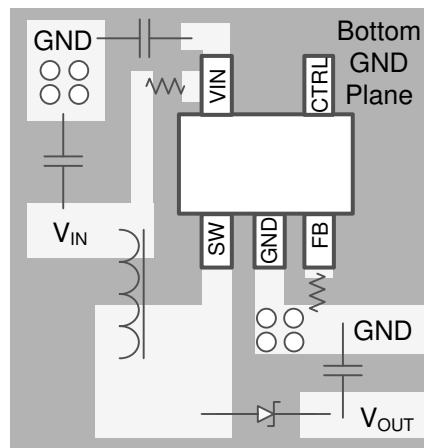

10-1. TPS92360 Board Layout

11 Device and Documentation Support

11.1 Device Support

11.2 ドキュメントの更新通知を受け取る方法

ドキュメントの更新についての通知を受け取るには、ti.com のデバイス製品フォルダを開いてください。「更新の通知を受け取る」をクリックして登録すると、変更されたすべての製品情報に関するダイジェストを毎週受け取れます。変更の詳細については、修正されたドキュメントに含まれている改訂履歴をご覧ください。

11.3 サポート・リソース

[TI E2E™ サポート・フォーラム](#)は、エンジニアが検証済みの回答と設計に関するヒントをエキスパートから迅速かつ直接得ることができる場所です。既存の回答を検索したり、独自の質問をしたりすることで、設計に必要な支援を迅速に得ることができます。

リンクされているコンテンツは、該当する貢献者により、現状のまま提供されるものです。これらは TI の仕様を構成するものではなく、必ずしも TI の見解を反映したものではありません。TI の[使用条件](#)を参照してください。

11.4 Trademarks

TI E2E™ is a trademark of Texas Instruments.

すべての商標は、それぞれの所有者に帰属します。

11.5 静電気放電に関する注意事項



この IC は、ESD によって破損する可能性があります。テキサス・インスツルメンツは、IC を取り扱う際には常に適切な注意を払うことを推奨します。正しい ESD 対策をとらないと、デバイスを破損するおそれがあります。

ESD による破損は、わずかな性能低下からデバイスの完全な故障まで多岐にわたります。精密な IC の場合、パラメータがわずかに変化するだけで公表されている仕様から外れる可能性があるため、破損が発生しやすくなっています。

11.6 用語集

[TI 用語集](#) この用語集には、用語や略語の一覧および定義が記載されています。

12 Mechanical, Packaging, and Orderable Information

The following pages include mechanical, packaging, and orderable information. This information is the most current data available for the designated devices. This data is subject to change without notice and revision of this document. For browser-based versions of this data sheet, refer to the left-hand navigation.

PACKAGING INFORMATION

Orderable Device	Status (1)	Package Type	Package Drawing	Pins	Package Qty	Eco Plan (2)	Lead finish/ Ball material (6)	MSL Peak Temp (3)	Op Temp (°C)	Device Marking (4/5)	Samples
TPS92360DCKR	ACTIVE	SC70	DCK	5	3000	RoHS & Green	SN	Level-1-260C-UNLIM	-40 to 85	11X	Samples

(1) The marketing status values are defined as follows:

ACTIVE: Product device recommended for new designs.

LIFEBUY: TI has announced that the device will be discontinued, and a lifetime-buy period is in effect.

NRND: Not recommended for new designs. Device is in production to support existing customers, but TI does not recommend using this part in a new design.

PREVIEW: Device has been announced but is not in production. Samples may or may not be available.

OBSOLETE: TI has discontinued the production of the device.

(2) **RoHS:** TI defines "RoHS" to mean semiconductor products that are compliant with the current EU RoHS requirements for all 10 RoHS substances, including the requirement that RoHS substance do not exceed 0.1% by weight in homogeneous materials. Where designed to be soldered at high temperatures, "RoHS" products are suitable for use in specified lead-free processes. TI may reference these types of products as "Pb-Free".

RoHS Exempt: TI defines "RoHS Exempt" to mean products that contain lead but are compliant with EU RoHS pursuant to a specific EU RoHS exemption.

Green: TI defines "Green" to mean the content of Chlorine (Cl) and Bromine (Br) based flame retardants meet JS709B low halogen requirements of <=1000ppm threshold. Antimony trioxide based flame retardants must also meet the <=1000ppm threshold requirement.

(3) MSL, Peak Temp. - The Moisture Sensitivity Level rating according to the JEDEC industry standard classifications, and peak solder temperature.

(4) There may be additional marking, which relates to the logo, the lot trace code information, or the environmental category on the device.

(5) Multiple Device Markings will be inside parentheses. Only one Device Marking contained in parentheses and separated by a "-" will appear on a device. If a line is indented then it is a continuation of the previous line and the two combined represent the entire Device Marking for that device.

(6) Lead finish/Ball material - Orderable Devices may have multiple material finish options. Finish options are separated by a vertical ruled line. Lead finish/Ball material values may wrap to two lines if the finish value exceeds the maximum column width.

Important Information and Disclaimer:The information provided on this page represents TI's knowledge and belief as of the date that it is provided. TI bases its knowledge and belief on information provided by third parties, and makes no representation or warranty as to the accuracy of such information. Efforts are underway to better integrate information from third parties. TI has taken and continues to take reasonable steps to provide representative and accurate information but may not have conducted destructive testing or chemical analysis on incoming materials and chemicals. TI and TI suppliers consider certain information to be proprietary, and thus CAS numbers and other limited information may not be available for release.

In no event shall TI's liability arising out of such information exceed the total purchase price of the TI part(s) at issue in this document sold by TI to Customer on an annual basis.

DCK0005A



PACKAGE OUTLINE

SOT - 1.1 max height

SMALL OUTLINE TRANSISTOR



4214834/E 06/2024

NOTES:

1. All linear dimensions are in millimeters. Any dimensions in parenthesis are for reference only. Dimensioning and tolerancing per ASME Y14.5M.
2. This drawing is subject to change without notice.
3. Reference JEDEC MO-203.
4. Support pin may differ or may not be present.
5. Lead width does not comply with JEDEC.
6. Body dimensions do not include mold flash, protrusions, or gate burrs. Mold flash, protrusions, or gate burrs shall not exceed 0.25mm per side

EXAMPLE BOARD LAYOUT

DCK0005A

SOT - 1.1 max height

SMALL OUTLINE TRANSISTOR



LAND PATTERN EXAMPLE
EXPOSED METAL SHOWN
SCALE:18X



SOLDER MASK DETAILS

4214834/E 06/2024

NOTES: (continued)

- 7. Publication IPC-7351 may have alternate designs.
- 8. Solder mask tolerances between and around signal pads can vary based on board fabrication site.

EXAMPLE STENCIL DESIGN

DCK0005A

SOT - 1.1 max height

SMALL OUTLINE TRANSISTOR



SOLDER PASTE EXAMPLE
BASED ON 0.125 THICK STENCIL
SCALE: 18X

4214834/E 06/2024

NOTES: (continued)

9. Laser cutting apertures with trapezoidal walls and rounded corners may offer better paste release. IPC-7525 may have alternate design recommendations.
10. Board assembly site may have different recommendations for stencil design.

重要なお知らせと免責事項

TI は、技術データと信頼性データ(データシートを含みます)、設計リソース(リファレンス・デザインを含みます)、アプリケーションや設計に関する各種アドバイス、Web ツール、安全性情報、その他のリソースを、欠陥が存在する可能性のある「現状のまま」提供しており、商品性および特定目的に対する適合性の黙示保証、第三者の知的財産権の非侵害保証を含むいかなる保証も、明示的または黙示的にかかわらず拒否します。

これらのリソースは、TI 製品を使用する設計の経験を積んだ開発者への提供を意図したものです。(1) お客様のアプリケーションに適した TI 製品の選定、(2) お客様のアプリケーションの設計、検証、試験、(3) お客様のアプリケーションに該当する各種規格や、その他のあらゆる安全性、セキュリティ、規制、または他の要件への確実な適合に関する責任を、お客様のみが単独で負うものとします。

上記の各種リソースは、予告なく変更される可能性があります。これらのリソースは、リソースで説明されている TI 製品を使用するアプリケーションの開発の目的でのみ、TI はその使用をお客様に許諾します。これらのリソースに関して、他の目的で複製することや掲載することは禁止されています。TI や第三者の知的財産権のライセンスが付与されている訳ではありません。お客様は、これらのリソースを自身で使用した結果発生するあらゆる申し立て、損害、費用、損失、責任について、TI およびその代理人を完全に補償するものとし、TI は一切の責任を拒否します。

TI の製品は、[TI の販売条件](#)、または [ti.com](#) やかかる TI 製品の関連資料などのいずれかを通じて提供する適用可能な条項の下で提供されています。TI がこれらのリソースを提供することは、適用される TI の保証または他の保証の放棄の拡大や変更を意味するものではありません。

お客様がいかなる追加条項または代替条項を提案した場合でも、TI はそれらに異議を唱え、拒否します。

郵送先住所 : Texas Instruments, Post Office Box 655303, Dallas, Texas 75265
Copyright © 2024, Texas Instruments Incorporated