

TS3L501E 11 チャンネル SPDT / 22 ビット - 11 ビット・マルチプレクサ / デマルチプレクサ・イーサネット LAN スイッチ、パワーダウン・モード付き

1 特長

- パワーダウン・モードを内蔵
- 広い帯域幅 (BW = 600MHz (標準値))
- 小さいクロストーク ($X_{TALK} = -37\text{dB}$ (標準値)、250MHz 時)
- 小さいビット間スキュー ($t_{sk(o)} \leq 100\text{ps}$)
- 小さくフラットなオン抵抗 ($r_{on} = 4\Omega$ (標準値)、 $r_{on(Flat)} = 0.5\Omega$ (標準値))
- 小さい入力および出力容量 ($C_{ON} = 9\text{pF}$ (標準値))
- データ I/O ポートでのレール・ツー・レールのスイッチング (0V~3.6V)
- V_{CC} 動作範囲: 3V~3.6V
- パワーダウン・モードのサポート
- JESD 78、Class II 準拠で 100mA 超のラッチアップ性能
- ESD 性能 (A、B、C、LED ピン)
 - $\pm 4\text{kV}$: IEC61000-4-2、接触放電
 - 6kV: JESD22-A114E、人体モデル (スイッチ I/O ピンと GND との間)
- ESD 性能 (すべてのピン)
 - 2kV: JESD22-A114E、人体モデル

2 アプリケーション

- 10/100/1000 Base-T 信号のスイッチング
- 差動 (LVDS および LVPECL) 信号のスイッチング
- オーディオおよびビデオのスイッチング
- ハブおよびルータ信号のスイッチング

3 概要

TS3L501E は、選択入力 (SEL) とパワーダウン・モード入力を備えた 11 チャンネル SPDT アナログ・スイッチまたは 22 ビット - 11 ビット・マルチプレクサ / デマルチプレクサ LAN スイッチです。本デバイスは、LED 信号を示すステータスを切り替えるための追加の I/O を備えており、また優れた ESD 保護機能を備えています。SEL 入力は、マルチプレクサまたはデマルチプレクサのデータ・パスを制御します。パワーダウン入力を使うと、モード選択によって消費電流を最小限に抑えるために、本デバイスをスタンバイ・モードに移行させることができます。

本デバイスは、オン抵抗 (r_{on}) が小さくフラットであり、オン抵抗のマッチングが非常に優れています。入力または出力の静電容量が小さく、帯域幅が広く、スキューが小さく、チャンネル間のクロストークが小さいため、このデバイスは 10/100/1000 Base-T などの各種 LAN アプリケーションに適しています。このデバイスは、LAN アプリケーションの機械式リレーを置き換えるために使用できます。本デバイスは、10/100 Base-T のイーサネット・トランシーバからの信号を、ラップトップやドッキング・ステーションの RJ-45 LAN コネクタへ転送するためにも使用できます。

このデバイスは、 $-40^{\circ}\text{C} \sim 85^{\circ}\text{C}$ の周囲温度範囲で動作が規定されています。

パッケージ情報 (1)

部品番号	パッケージ	本体サイズ (公称)
TS3L501E	RUA (WQFN, 42)	9.00mm × 3.50mm

- (1) 利用可能なパッケージについては、このデータシートの末尾にある注文情報を参照してください。

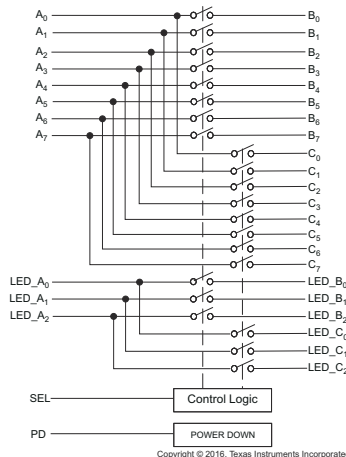

機能ブロック図



Table of Contents

1 特長	1	7.5 HP8753ES Setup.....	13
2 アプリケーション	1	8 Detailed Description	14
3 概要	1	8.1 Overview.....	14
4 Revision History	2	8.2 Functional Block Diagram.....	14
5 Pin Configuration and Functions	3	8.3 Feature Description.....	14
6 Specifications	5	8.4 Device Functional Modes.....	14
6.1 Absolute Maximum Ratings.....	5	9 Application and Implementation	15
6.2 ESD Ratings.....	5	9.1 Application Information.....	15
6.3 Recommended Operating Conditions.....	5	9.2 Typical Application.....	15
6.4 Thermal Information.....	6	10 Power Supply Recommendations	16
6.5 Electrical Characteristics for 1000 Base-T Ethernet Switching.....	6	11 Layout	17
6.6 Electrical Characteristics for 10/100 Base-T Ethernet Switching.....	6	11.1 Layout Guidelines.....	17
6.7 Switching Characteristics.....	7	11.2 Layout Example.....	18
6.8 Dynamic Characteristics.....	7	12 Device and Documentation Support	19
6.9 Typical Characteristics.....	8	12.1 Documentation Support.....	19
7 Parameter Measurement Information	9	12.2 Receiving Notification of Documentation Updates..	19
7.1 Enable and Disable Times.....	9	12.3 サポート・リソース.....	19
7.2 Skew.....	10	12.4 Trademarks.....	19
7.3 HP8753ES Setup.....	11	12.5 Electrostatic Discharge Caution.....	19
7.4 HP8753ES Setup.....	12	12.6 Glossary.....	19
		13 Mechanical, Packaging, and Orderable Information	19

4 Revision History

資料番号末尾の英字は改訂を表しています。その改訂履歴は英語版に準じています。

Changes from Revision C (December 2017) to Revision D (October 2022)	Page
• 文書全体の表、図、相互参照の採番方法を更新.....	1
• データシート全体にわたって 8 チャンネルを 11 チャンネルに変更.....	1
• データシート全体にわたって「16 ビット - 8 ビット」を「22 ビット - 11 ビット」に変更.....	1
Changes from Revision B (May 2016) to Revision C (December 2017)	Page
• Added pin numbers 4, 8, 14, 21, 30, 39 to V_{DD} in the <i>Pin Functions</i> table.....	3
Changes from Revision A (September 2010) to Revision B (May 2016)	Page
• 「ESD 定格」表、「機能説明」セクション、「デバイスの機能モード」セクション、「アプリケーションと実装」セクション、「電源に関する推奨事項」セクション、「レイアウト」セクション、「デバイスおよびドキュメントのサポート」セクション、「メカニカル、パッケージ、および注文情報」セクションを追加。.....	1
• 「注文情報」表を削除.....	1

5 Pin Configuration and Functions

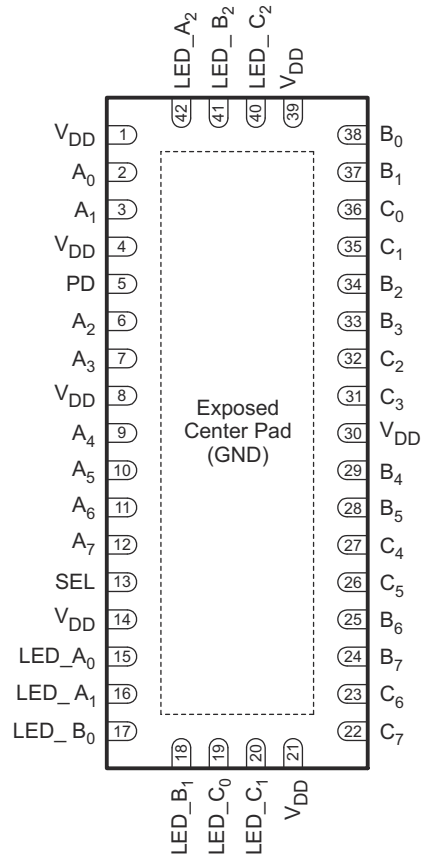

The exposed center pad must be connected to GND.

图 5-1. RUA Package, 42-Pin WQFN (Top View)

表 5-1. Pin Functions

PIN		TYPE ⁽¹⁾	DESCRIPTION
NAME	NO.		
A ₀	2	I/O	Port A Common I/O signal path
A ₁	3	I/O	Port A Common I/O signal path
A ₂	6	I/O	Port A Common I/O signal path
A ₃	7	I/O	Port A Common I/O signal path
A ₄	9	I/O	Port A Common I/O signal path
A ₅	10	I/O	Port A Common I/O signal path
A ₆	11	I/O	Port A Common I/O signal path
A ₇	12	I/O	Port A Common I/O signal path
B ₀	38	I/O	Port B I/O signal path
B ₁	37	I/O	Port B I/O signal path
B ₂	34	I/O	Port B I/O signal path
B ₃	33	I/O	Port B I/O signal path
B ₄	29	I/O	Port B I/O signal path
B ₅	28	I/O	Port B I/O signal path
B ₆	25	I/O	Port B I/O signal path
B ₇	24	I/O	Port B I/O signal path

表 5-1. Pin Functions (continued)

PIN		TYPE ⁽¹⁾	DESCRIPTION
NAME	NO.		
C ₀	36	I/O	Port C I/O signal path
C ₁	35	I/O	Port C I/O signal path
C ₂	32	I/O	Port C I/O signal path
C ₃	31	I/O	Port C I/O signal path
C ₄	27	I/O	Port C I/O signal path
C ₅	26	I/O	Port C I/O signal path
C ₆	23	I/O	Port C I/O signal path
C ₇	22	I/O	Port C I/O signal path
GND	Exposed Center Pad	—	Ground
LED_A ₀	15	I/O	Port A LED I/O Common signal path, (may also be used as a general purpose signal path)
LED_A ₁	16	I/O	Port A LED Common I/O signal path, (may also be used as a general purpose signal path)
LED_A ₂	42	I/O	Port A LED Common I/O signal path, (may also be used as a general purpose signal path)
LED_B ₀	17	I/O	Port B LED I/O signal path, (may also be used as a general purpose signal path)
LED_B ₁	18	I/O	Port B LED I/O signal path, (may also be used as a general purpose signal path)
LED_B ₂	41	I/O	Port B LED I/O signal path, (may also be used as a general purpose signal path)
LED_C ₀	19	I/O	Port C LED I/O signal path, (may also be used as a general purpose signal path)
LED_C ₁	20	I/O	Port C LED I/O signal path, (may also be used as a general purpose signal path)
LED_C ₂	40	I/O	Port C LED I/O signal path, (may also be used as a general purpose signal path)
PD	5	I	Power down input, active high
SEL	13	I	Select input
V _{DD}	1, 4, 8, 14, 21, 30, 39	—	Power

(1) I = input, O = output

6 Specifications

6.1 Absolute Maximum Ratings

over operating free-air temperature range (unless otherwise noted)⁽¹⁾

		MIN	MAX	UNIT	
V _{DD}	Supply voltage	-0.5	4.6	V	
V _{IN}	Control input voltage ^{(2) (3)}	-0.5	7	V	
V _{I/O}	Switch I/O voltage ^{(2) (3) (4)}	-0.5	7	V	
I _{IK}	Control input clamp current	V _{IN} < 0		-50	mA
I _{I/OK}	I/O port clamp current	V _{I/O} < 0		-50	mA
I _{I/O}	ON-state switch current ⁽⁵⁾			±128	mA
Continuous current through V _{DD} or GND				±100	mA
T _{stg}	Storage temperature	-65	150	°C	

- (1) Stresses beyond those listed under *Absolute Maximum Ratings* may cause permanent damage to the device. These are stress ratings only, which do not imply functional operation of the device at these or any other conditions beyond those indicated under *Recommended Operating Conditions*. Exposure to absolute-maximum-rated conditions for extended periods may affect device reliability.
- (2) All voltages are with respect to ground, unless otherwise specified.
- (3) The input and output voltage ratings may be exceeded if the input and output clamp-current ratings are observed.
- (4) V_I and V_O are used to denote specific conditions for V_{I/O}.
- (5) I_I and I_O are used to denote specific conditions for I_{I/O}.

6.2 ESD Ratings

		VALUE	UNIT		
V _(ESD)	Electrostatic discharge	Human-body model (HBM), per ANSI/ESDA/ JEDEC JS-001 ⁽¹⁾	All pins except 1, 4, 5, 8, 13, 14, 21, 30, and 39	±6000	V
			Pins 1, 4, 5, 8, 13, 14, 21, 30, and 39	±2000	
		Charged-device model (CDM), per JEDEC specification JESD22-C101 ⁽²⁾	±1500		

- (1) JEDEC document JEP155 states that 500-V HBM allows safe manufacturing with a standard ESD control process.
- (2) JEDEC document JEP157 states that 250-V CDM allows safe manufacturing with a standard ESD control process.

6.3 Recommended Operating Conditions

over operating free-air temperature range (unless otherwise noted)⁽¹⁾

		MIN	MAX	UNIT
V _{DD}	Supply voltage	3	3.6	V
V _{IH}	High-level control input voltage (SEL)	2	5.5	V
V _{IL}	Low-level control input voltage (SEL)	0	0.8	V
V _{IN}	Input voltage (SEL)	0	5.5	V
V _{I/O}	Input or output voltage	0	V _{DD}	V
T _A	Operating free-air temperature	-40	85	°C

- (1) All unused control inputs of the device must be held at V_{DD} or GND to ensure proper device operation. See the TI application report, *Implications of Slow or Floating CMOS Inputs*, [SCBA004](#).

6.4 Thermal Information

THERMAL METRIC ⁽¹⁾		TS3L501E	UNIT
		RUA (WQFN)	
		42 PINS	
R _{θJA}	Junction-to-ambient thermal resistance ⁽²⁾	30.9	°C/W
R _{θJC(top)}	Junction-to-case (top) thermal resistance	12.8	°C/W
R _{θJB}	Junction-to-board thermal resistance	5.2	°C/W
ψ _{JT}	Junction-to-top characterization parameter	0.2	°C/W
ψ _{JB}	Junction-to-board characterization parameter	5	°C/W
R _{θJC(bot)}	Junction-to-case (bottom) thermal resistance	1.5	°C/W

- (1) For more information about traditional and new thermal metrics, see the [Semiconductor and IC Package Thermal Metrics](#) application report.
- (2) The package thermal impedance is calculated in accordance with JESD 51-7.

6.5 Electrical Characteristics for 1000 Base-T Ethernet Switching

for 1000 Base-T Ethernet switching over recommended operating free-air temperature range, V_{DD} = 3.3 V ± 0.3 V (unless otherwise noted)

PARAMETER		TEST CONDITIONS ⁽¹⁾	MIN	TYP ⁽²⁾	MAX	UNIT
V _{IK}	SEL, PD	V _{DD} = 3.6 V, I _{IN} = -18 mA	-0.7	-1.2		V
I _{IH}	SEL, PD	V _{DD} = 3.6 V, V _{IN} = V _{DD}			±2	μA
I _{IL}	SEL, PD	V _{DD} = 3.6 V, V _{IN} = GND			±1	μA
I _{OFF}	SEL, PD	V _{DD} = 0 V, V _{IN} = 0 to 3.6 V			±1	μA
I _{CC}		V _{DD} = 3.6 V, I _{I/O} = 0, switch ON or OFF		250	600	μA
I _{CC_PD}		V _{DD} = 3.6 V, V _{IN} = 3.6 V, PD = high		1		
C _{IN}	SEL, PD	f = 1 MHz, V _{IN} = 0		2.6	3	pF
C _{OFF}	B or C port	V _I = 0, f = 1 MHz, outputs open, switch OFF		3	4	pF
C _{ON}		V _I = 0, f = 1 MHz, outputs open, switch ON		9	9.8	pF
r _{on}		V _{DD} = 3 V, 1.5 V ≤ V _I ≤ V _{DD} , I _O = -40 mA		4	8	Ω
r _{on(flat)} ⁽³⁾		V _{DD} = 3 V, V _I = 1.5 V and V _{DD} , I _O = -40 mA		0.7		Ω
Δr _{on} ⁽⁴⁾		V _{DD} = 3 V, 1.5 V ≤ V _I ≤ V _{DD} , I _O = -40 mA		0.8	1.5	Ω

- (1) V_I, V_O, I_I, and I_O refer to I/O pins. V_{IN} refers to the control inputs.
- (2) All typical values are at V_{DD} = 3.3 V (unless otherwise noted), T_A = 25°C.
- (3) r_{on(flat)} is the difference of r_{on} in a given channel at specified voltages.
- (4) Δr_{on} is the difference of r_{on} from center (A₄, A₅) ports to any other port.

6.6 Electrical Characteristics for 10/100 Base-T Ethernet Switching

for 10/100 Base-T Ethernet switching over recommended operating free-air temperature range, $V_{DD} = 3.3 \text{ V} \pm 0.3 \text{ V}$ (unless otherwise noted)

PARAMETER		TEST CONDITIONS ⁽¹⁾	MIN	TYP ⁽²⁾	MAX	UNIT
V_{IK}	SEL, PD	$V_{DD} = 3.6 \text{ V}$, $I_{IN} = -18 \text{ mA}$	-0.7	-1.2		V
I_{IH}	SEL, PD	$V_{DD} = 3.6 \text{ V}$, $V_{IN} = V_{DD}$			± 2	μA
I_{IL}	SEL, PD	$V_{DD} = 3.6 \text{ V}$, $V_{IN} = \text{GND}$			± 1	μA
I_{OFF}	SEL, PD	$V_{DD} = 0 \text{ V}$, $V_{IN} = 0$ to 3.6 V			± 1	μA
I_{CC}		$V_{DD} = 3.6 \text{ V}$, $I_{IO} = 0$, switch ON or OFF		250	600	μA
I_{CC_PD}		$V_{DD} = 3.6 \text{ V}$, $V_{IN} = 3.6 \text{ V}$, PD = high		1		
C_{IN}	SEL, PD	$f = 1 \text{ MHz}$, $V_{IN} = 0$		2.6	3.0	pF
C_{OFF}	B or C port	$V_I = 0$, $f = 10 \text{ MHz}$, outputs open, switch OFF		3	4	pF
C_{ON}		$V_I = 0$, $f = 10 \text{ MHz}$, outputs open, switch ON		9	9.8	pF
r_{on}		$V_{DD} = 3 \text{ V}$, $1.25 \text{ V} \leq V_I \leq V_{DD}$, $I_O = -10 \text{ mA}$ to -30 mA		4	6	Ω
$r_{on(\text{flat})}$ ⁽³⁾		$V_{DD} = 3 \text{ V}$, $V_I = 1.25 \text{ V}$ and V_{DD} , $I_O = -10 \text{ mA}$ to -30 mA		0.5		Ω
Δr_{on} ⁽⁴⁾		$V_{DD} = 3 \text{ V}$, $1.25 \text{ V} \leq V_I \leq V_{DD}$, $I_O = -10 \text{ mA}$ to -30 mA		0.8	1.5	Ω

- (1) V_I , V_O , I_I , and I_O refer to I/O pins. V_{IN} refers to the control inputs.
- (2) All typical values are at $V_{DD} = 3.3 \text{ V}$ (unless otherwise noted), $T_A = 25^\circ\text{C}$.
- (3) $r_{on(\text{flat})}$ is the difference of r_{on} in a given channel at specified voltages.
- (4) Δr_{on} is the difference of r_{on} from center (A_4 , A_5) ports to any other port.

6.7 Switching Characteristics

over recommended operating free-air temperature range, $V_{DD} = 3.3 \text{ V} \pm 0.3 \text{ V}$, $R_L = 200 \Omega$, $C_L = 10 \text{ pF}$ (unless otherwise noted) (see [7-1](#) and [7-2](#))

PARAMETER	FROM (INPUT)	TO (OUTPUT)	MIN	TYP ⁽¹⁾	MAX	UNIT
t_{pd} ⁽²⁾	A or B/C	B/C or A		0.3		ns
t_{PZH} , t_{PZL}	SEL	A or B/C	0.5		15	ns
t_{PHZ} , t_{PLZ}	SEL	A or B/C	0.9		9	ns
$t_{sk(o)}$ ⁽³⁾	A or B/C	B/C or A		50	100	ps
$t_{sk(p)}$ ⁽⁴⁾	A or B/C	B/C or A		50	100	ps
t_{ON}/t_{OFF} ⁽⁵⁾	PD	A or B/C			250	ns

- (1) All typical values are at $V_{DD} = 3.3 \text{ V}$ (unless otherwise noted), $T_A = 25^\circ\text{C}$.
- (2) The propagation delay is the calculated RC time constant of the typical ON-state resistance of the switch and the specified load capacitance when driven by an ideal voltage source (zero output impedance).
- (3) Output skew between center port (A_4 to A_5) to any other port
- (4) Skew between opposite transitions of the same output in a given device $|t_{PHL} - t_{PLH}|$
- (5) Device enable/disable time from PD

6.8 Dynamic Characteristics

over recommended operating free-air temperature range, $V_{DD} = 3.3 \text{ V} \pm 0.3 \text{ V}$ (unless otherwise noted)

PARAMETER	TEST CONDITIONS	TYP ⁽¹⁾	UNIT
X_{TALK}	$R_L = 50 \Omega$, $f = 250 \text{ MHz}$, see 7-4	-37	dB
O_{IRR}	$R_L = 50 \Omega$, $f = 250 \text{ MHz}$, see 7-5	-37	dB
BW	See 7-3	600	MHz

- (1) All typical values are at $V_{CC} = 3.3 \text{ V}$ (unless otherwise noted), $T_A = 25^\circ\text{C}$.

6.9 Typical Characteristics

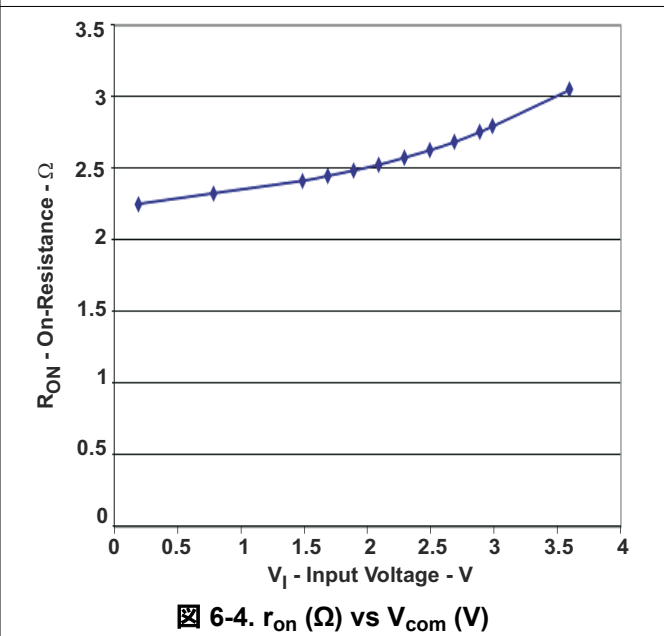
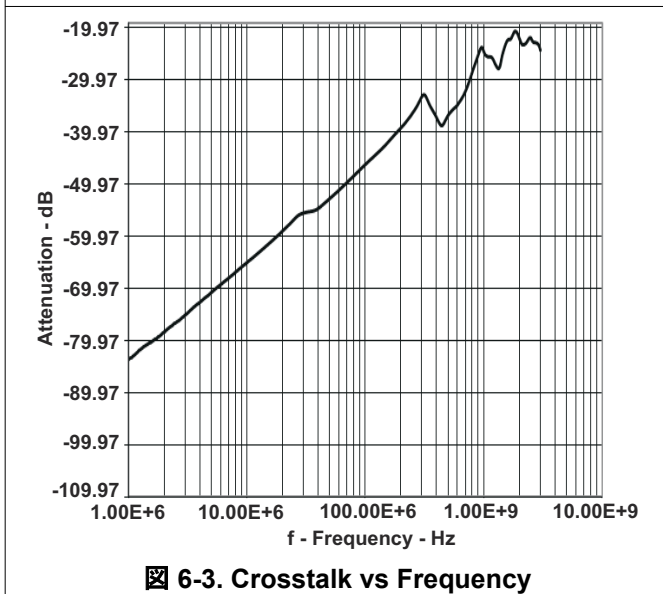
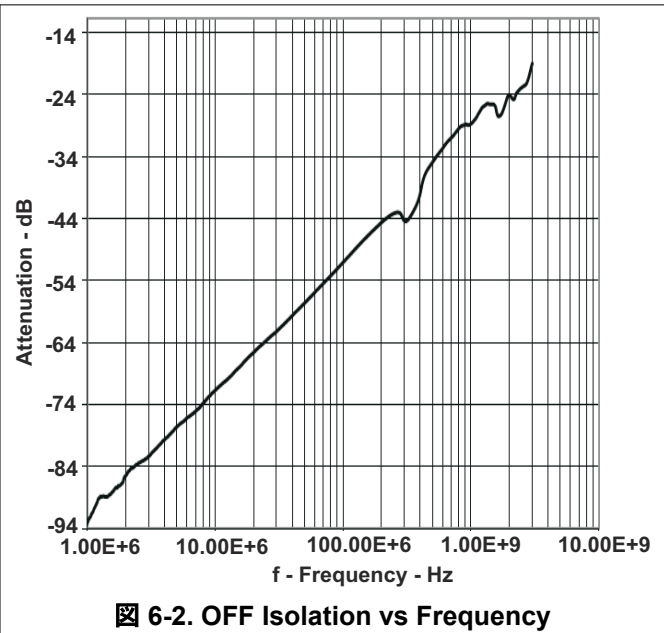
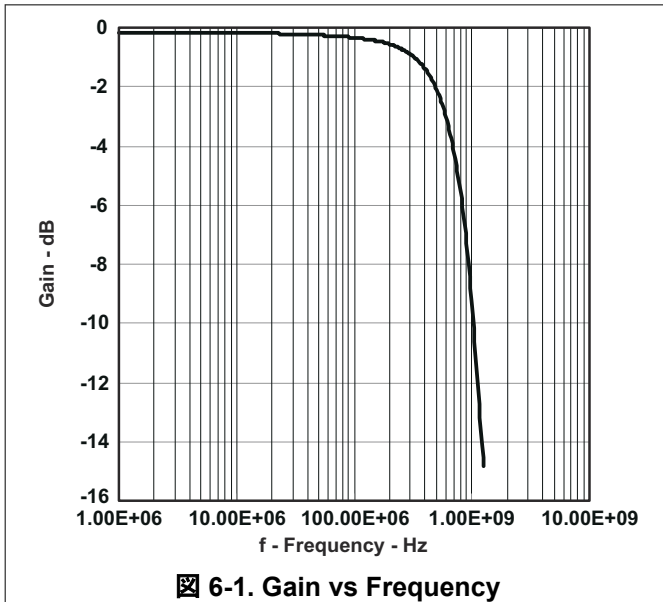

7 Parameter Measurement Information

7.1 Enable and Disable Times

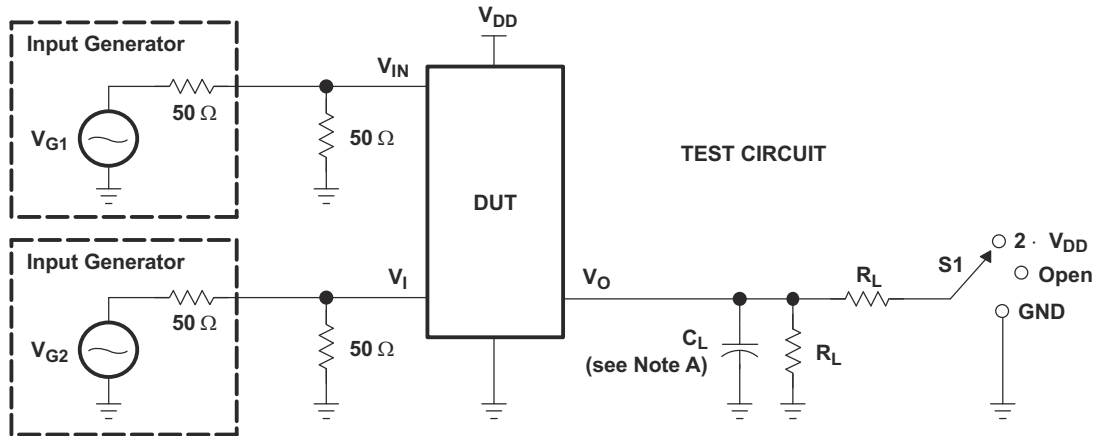

TEST	V _{DD}	S1	R _L	V _{in}	C _L	V _Δ
t _{PLZ} /t _{PZL}	3.3 V	2 · V _{DD}	200 Ω	GND	10 pF	0.3 V
t _{PHZ} /t _{PZH}	3.3 V	GND	200 Ω	V _{DD}	10 pF	0.3 V

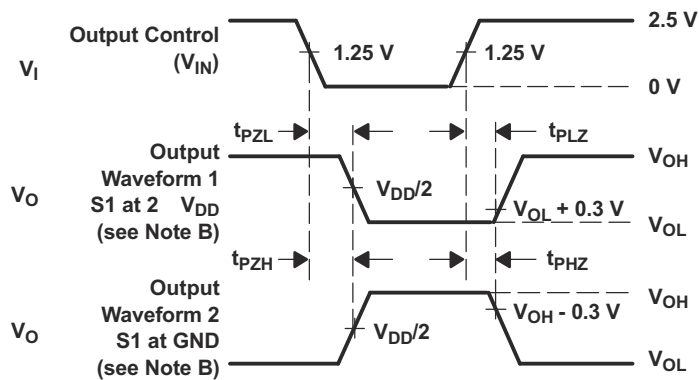

VOLTAGE WAVEFORMS
ENABLE AND DISABLE TIMES

- NOTES:
- C_L includes probe and jig capacitance.
 - Waveform 1 is for an output with internal conditions such that the output is low except when disabled by the output control. Waveform 2 is for an output with internal conditions such that the output is high, except when disabled by the output control.
 - All input pulses are supplied by generators having the following characteristics: PRR ≤ 10 MHz, Z_O = 50 Ω, t_r ≤ 2.5 ns, t_f ≤ 2.5 ns.
 - The outputs are measured one at a time, with one transition per measurement.
 - t_{PLZ} and t_{PHZ} are the same as t_{dis}.
 - t_{PZL} and t_{PZH} are the same as t_{en}.

7-1. Test Circuit and Voltage Waveforms

7.2 Skew

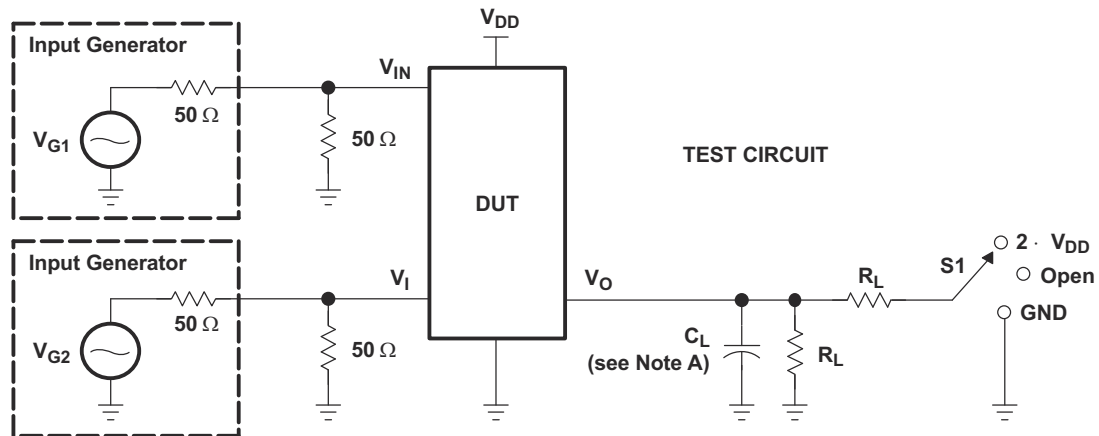

TEST	V _{DD}	S1	R _L	V _{in}	C _L
t _{sk(o)}	3.3 V ± 0.3 V	Open	200 Ω	V _{DD} or GND	10 pF
t _{sk(p)}	3.3 V ± 0.3 V	Open	200 Ω	V _{DD} or GND	10 pF

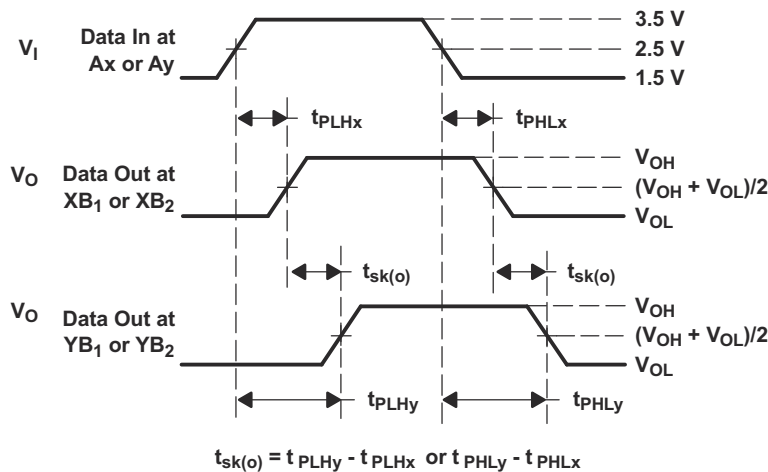

**VOLTAGE WAVEFORMS
OUTPUT SKEW (t_{sk(o)})**

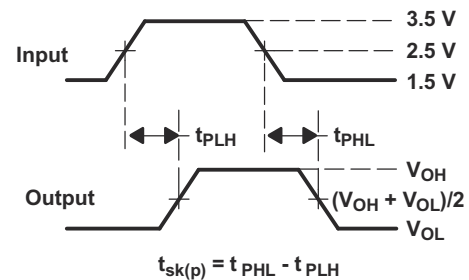

**VOLTAGE WAVEFORMS
PULSE SKEW [t_{sk(p)}]**

- NOTES: A. C_L includes probe and jig capacitance.
 B. Waveform 1 is for an output with internal conditions such that the output is low except when disabled by the output control. Waveform 2 is for an output with internal conditions such that the output is high, except when disabled by the output control.
 C. All input pulses are supplied by generators having the following characteristics: PRR ≤ 10 MHz, Z_O = 50 Ω, t_r ≤ 2.5 ns, t_f ≤ 2.5 ns.
 D. The outputs are measured one at a time, with one transition per measurement.

7-2. Test Circuit and Voltage Waveforms

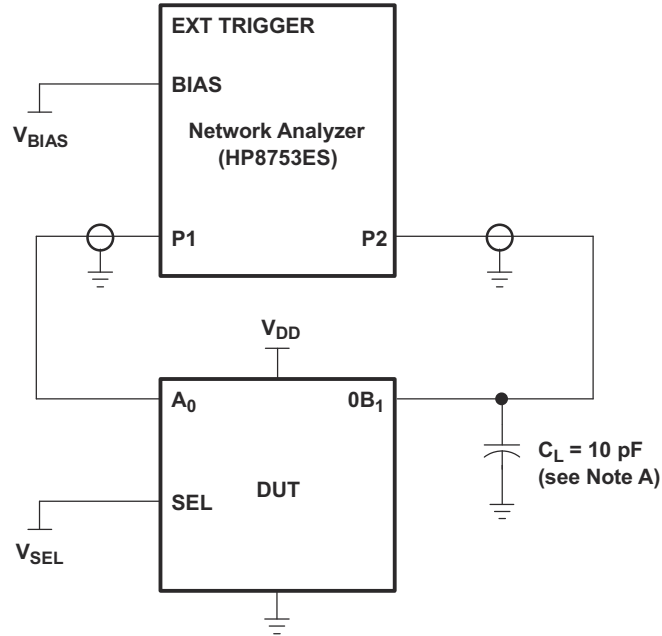

A. C_L includes probe and jig capacitance.

7-3. Test Circuit for Frequency Response (BW)

Frequency response is measured at the output of the ON channel. For example, when $V_{SEL} = 0$ and A_0 is the input, the output is measured at $0B_1$. All unused analog I/O ports are left open.

7.3 HP8753ES Setup

Average = 4

RBW = 3 kHz

$V_{BIAS} = 0.35 \text{ V}$

ST = 2 s

P1 = 0 dBm

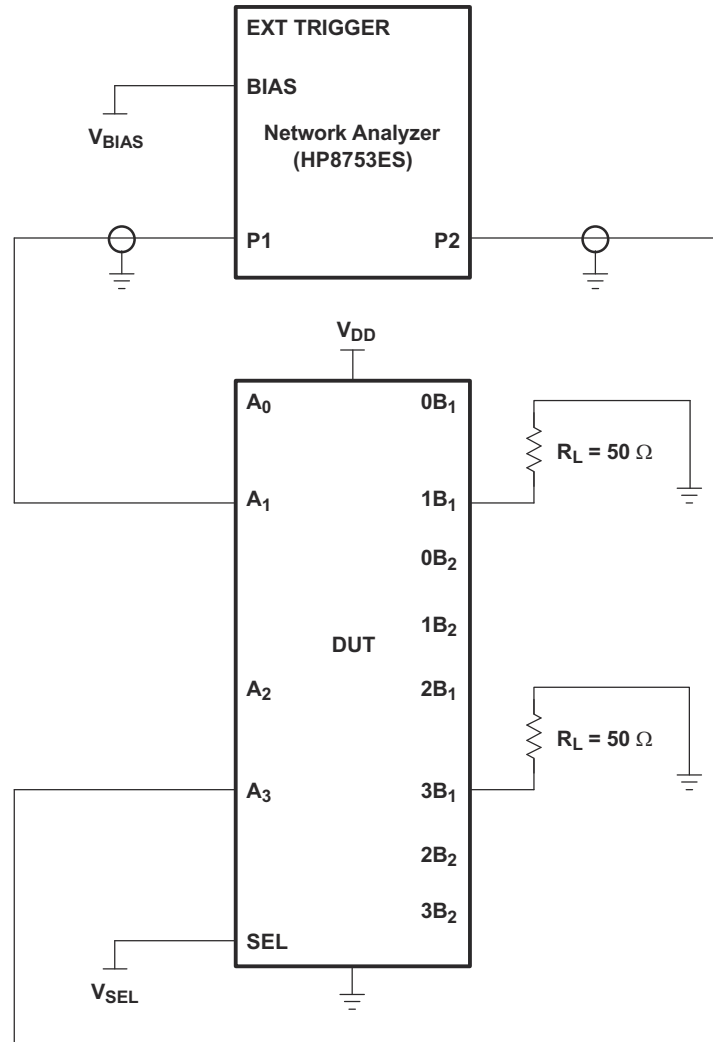

- A. C_L includes probe and jig capacitance.
- B. A 50- Ω termination resistor is needed to match the loading of the network analyzer.

7-4. Test Circuit for Crosstalk (X_{TALK})

Crosstalk is measured at the output of the nonadjacent ON channel. For example, when $V_{SEL} = 0$ and A_1 is the input, the output is measured at A_3 . All unused analog input (A) ports are connected to GND, and output (B) ports are left open.

7.4 HP8753ES Setup

Average = 4
 RBW = 3 kHz
 $V_{BIAS} = 0.35\text{ V}$
 ST = 2 s
 P1 = 0 dBm

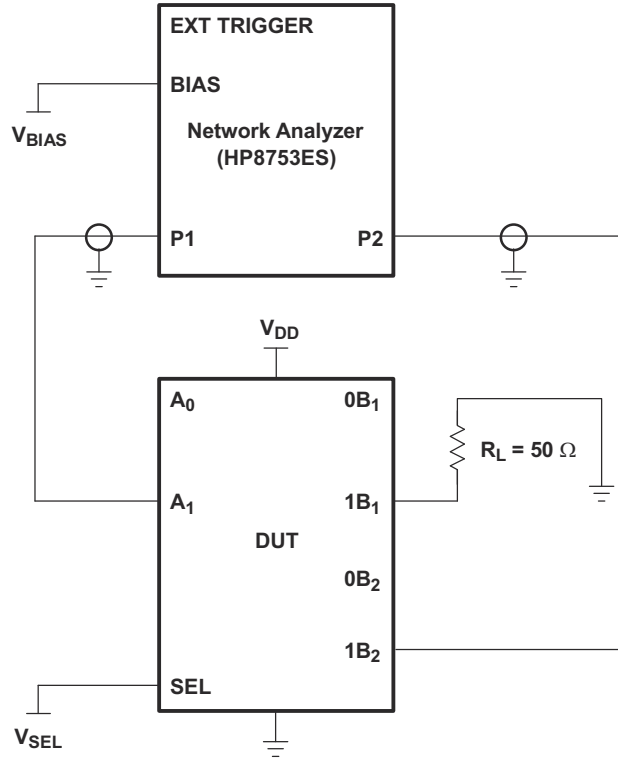

- A. C_L includes probe and jig capacitance.
- B. A 50- Ω termination resistor is needed to match the loading of the network analyzer.

7-5. Test Circuit for OFF Isolation (O_{IRR})

OFF isolation is measured at the output of the OFF channel. For example, when $V_{SEL} = GND$ and A_1 is the input, the output is measured at $1B_2$. All unused analog input (A) ports are connected to ground, and output (B) ports are left open.

7.5 HP8753ES Setup

Average = 4
 RBW = 3 kHz
 $V_{BIAS} = 0.35\text{ V}$
 ST = 2 s
 P1 = 0 dBm

8 Detailed Description

8.1 Overview

The TS3L501E is a 11-channel SPDT analog switch or 22-bit to 11-bit multiplexer/demultiplexer LAN switch with a single select (SEL) input and Power Down Mode input. The device provides additional I/Os for switching status indicating LED signals and includes high ESD protection. SEL input controls the data path of the multiplexer/demultiplexer. Power Down input can put the device into the standby mode for minimizing current consumption per mode selection.

The device provides a low and flat ON-state resistance (ron) and an excellent ON-state resistance match. Low input/output capacitance, high bandwidth, low skew, and low crosstalk among channels make this device suitable for various LAN applications, such as 10/100/1000 Base-T. This device can be used to replace mechanical relays in LAN applications. It also can be used to route signals from a 10/100 Base-T Ethernet transceiver to the RJ-45 LAN connectors in laptops or in docking stations.

8.2 Functional Block Diagram

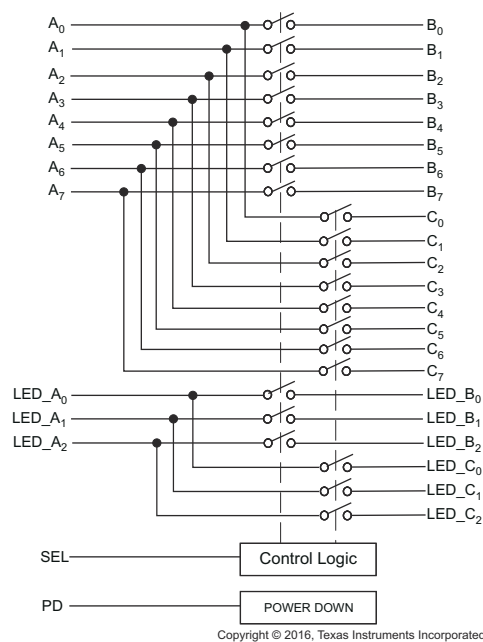

8-1. Logic Diagram (Positive Logic)

8.3 Feature Description

The TS3L501E device switches and pin out are optimized for ethernet application but the device can be used for many applications where a multi-channel, 1:2 SPDT, high bandwidth switch is needed.

8.4 Device Functional Modes

The TS3L501E supports a power down mode which reduces the current consumption of the device and places all the signal paths in a high impedance state. To place the TS3L501E in power down mode, set the PD pin with a logic high voltage as seen in [表 8-1](#).

表 8-1. Function Table

PD	SEL	FUNCTION
L	L	A _n to B _n , LED_A _n to LED_B _n
L	H	A _n to C _n , LED_A _n to LED_C _n
H	X	Hi-Z

9 Application and Implementation

注

以下のアプリケーション情報は、TI の製品仕様に含まれるものではなく、TI ではその正確性または完全性を保証いたしません。個々の目的に対する製品の適合性については、お客様の責任で判断していただくこととなります。お客様は自身の設計実装を検証しテストすることで、システムの機能を確認する必要があります。

9.1 Application Information

There are many Local Area Network (LAN) applications in which the ethernet hubs or controllers have a limited number of I/Os or need to route signals from a single ethernet PHY to multiple ethernet jacks. The TS3L501E solution can effectively expand the limited I/Os by switching between multiple ethernet jacks to interface them to a single ethernet PHY.

The LED_A_n, LED_B_n, and LED_C_n pins are rated the same as the other signal path pins so you may use these pins as extra data paths if needed.

9.2 Typical Application

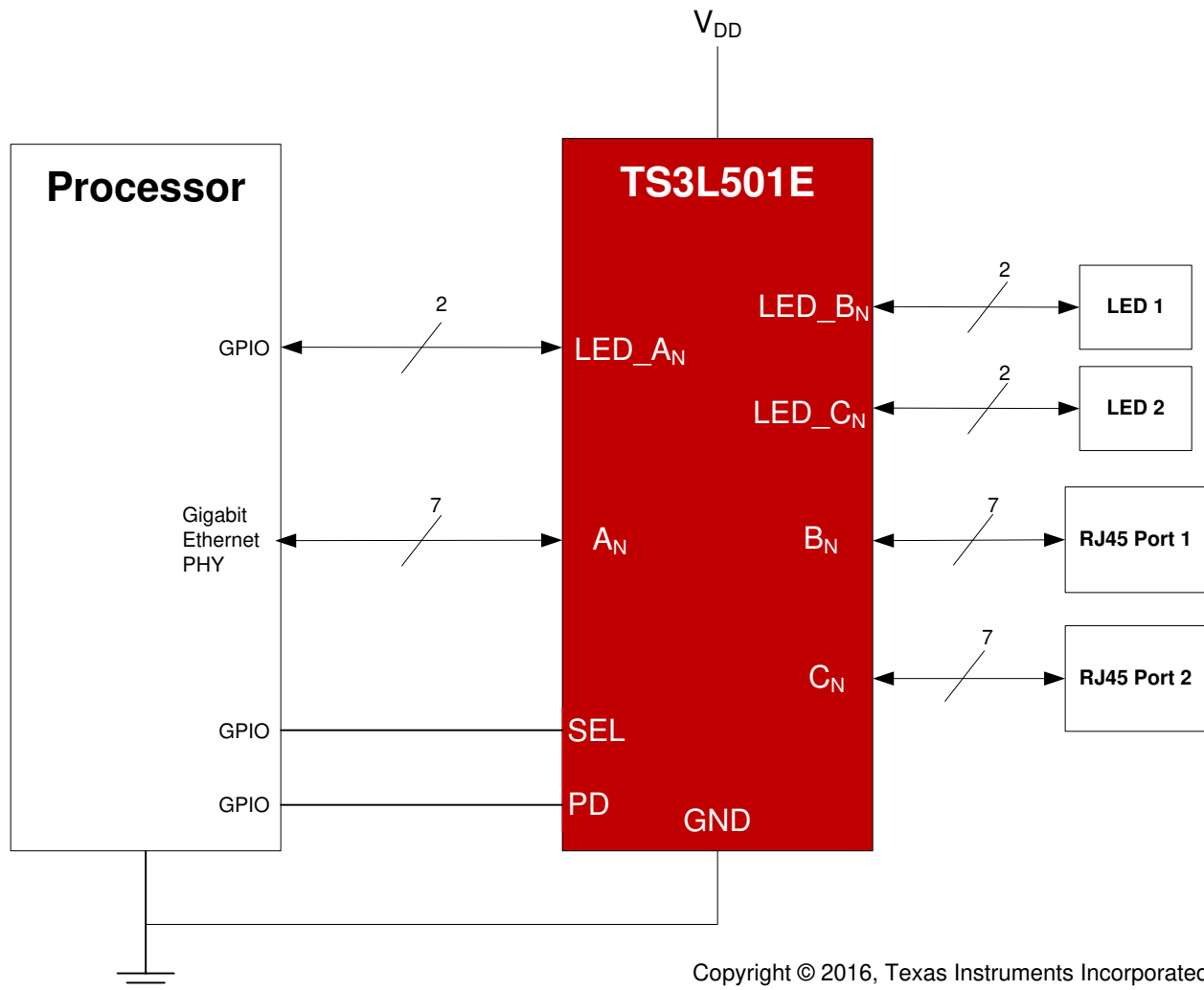

Copyright © 2016, Texas Instruments Incorporated

図 9-1. Typical Application Schematic

9.2.1 Design Requirements

Ensure that all of the signals passing through the switch are within the recommended operating ranges. To ensure proper performance, see [Recommended Operating Conditions](#).

9.2.2 Detailed Design Procedure

The TS3L501E can be properly operated without any external components.

TI recommends that the digital control pins SEL and PD be pulled up to VCC or down to GND to avoid undesired switch positions that could result from the floating pin.

Connect the exposed thermal pad to ground.

9.2.3 Application Curves

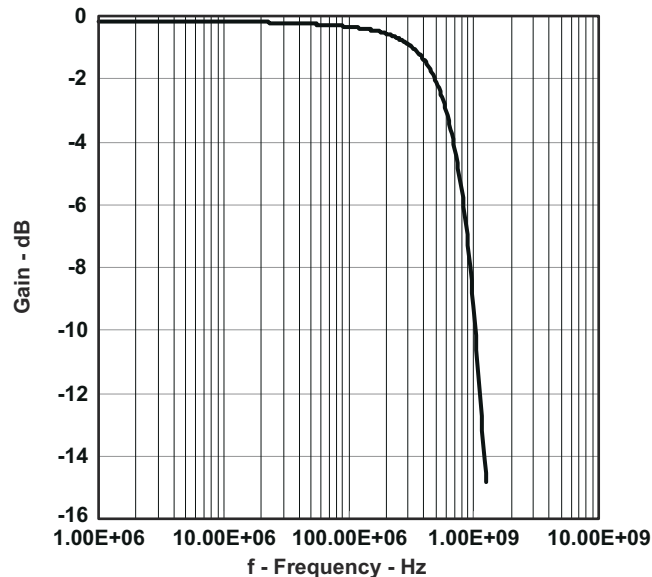

Figure 9-2. Gain vs Frequency

10 Power Supply Recommendations

Power to the device is supplied through the V_{DD} pins. TI recommends placing a bypass capacitor as close to the supply pin (VCC) as possible to help smooth out lower frequency noise to provide better load regulation across the frequency spectrum.

All V_{DD} pins are internally connected. One PCB layout option is to connect one of the V_{DD} to the power supply and leave the other V_{DD} pins open.

Supply the TS3L501E V_{DD} pins with the recommended voltage before applying a signal voltage to the I/O signal paths to avoid violating the recommended operating condition I/O voltage $0-V_{DD}$.

11 Layout

11.1 Layout Guidelines

- TI recommends keeping the high-speed signals as short as possible.
- Each via introduces discontinuities in the transmission line of the signal and increases the chance of picking up interference from the other layers of the board. Be careful when designing test points on twisted pair lines; through-hole pins are not recommended.
- When it becomes necessary to turn 90°, use two 45° turns or an arc instead of making a single 90° turn. This reduces reflections on the signal traces by minimizing impedance discontinuities.
- Do not route traces under or near crystals, oscillators, clock signal generators, switching regulators, mounting holes, magnetic devices or ICs that use or duplicate clock signals.
- Avoid stubs on the high-speed signals because they cause signal reflections. If a stub is unavoidable, then the stub must be less than 200 mm.
- Route all high-speed signal traces over continuous GND planes, with no interruptions. Avoid crossing over anti-etch, commonly found with plane splits.
- Due to high-frequency signals, a printed-circuit board with at least four layers is recommended; two signal layers separated by a ground and power layer as shown in [Figure 11-1](#).
- The majority of signal traces must run on a single layer, preferably Signal 1. Immediately next to this layer should be the GND plane, which is solid with no cuts. Avoid running signal traces across a split in the ground or power plane. When running across split planes is unavoidable, sufficient decoupling must be used. Minimizing the number of signal vias reduces EMI by reducing inductance at high frequencies.

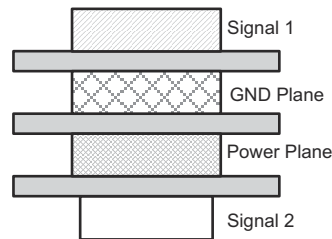
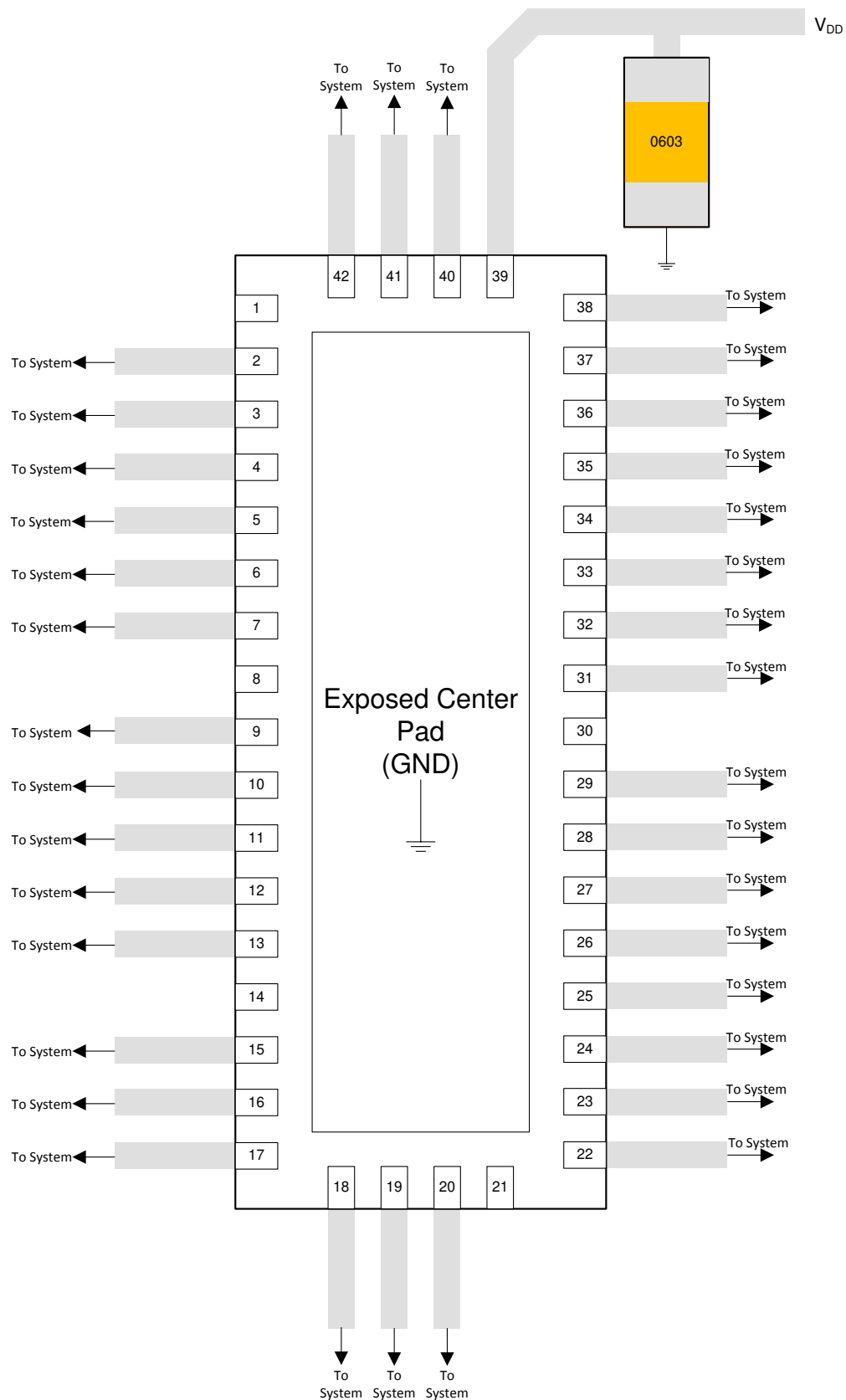

Figure 11-1. Four-Layer Board Stackup

11.2 Layout Example



 11-2. Layout Example

12 Device and Documentation Support

12.1 Documentation Support

12.1.1 Related Documentation

For related documentation, see the following:

- Texas Instruments, [Implications of Slow or Floating CMOS Inputs application note](#)

12.2 Receiving Notification of Documentation Updates

To receive notification of documentation updates, navigate to the device product folder on [ti.com](#). Click on [Subscribe to updates](#) to register and receive a weekly digest of any product information that has changed. For change details, review the revision history included in any revised document.

12.3 サポート・リソース

TI E2E™ サポート・フォーラムは、エンジニアが検証済みの回答と設計に関するヒントをエキスパートから迅速かつ直接得ることができる場所です。既存の回答を検索したり、独自の質問をしたりすることで、設計に必要な支援を迅速に得ることができます。

リンクされているコンテンツは、該当する貢献者により、現状のまま提供されるものです。これらは TI の仕様を構成するものではなく、必ずしも TI の見解を反映したものではありません。TI の[使用条件](#)を参照してください。

12.4 Trademarks

TI E2E™ is a trademark of Texas Instruments.

すべての商標は、それぞれの所有者に帰属します。

12.5 Electrostatic Discharge Caution



This integrated circuit can be damaged by ESD. Texas Instruments recommends that all integrated circuits be handled with appropriate precautions. Failure to observe proper handling and installation procedures can cause damage.

ESD damage can range from subtle performance degradation to complete device failure. Precision integrated circuits may be more susceptible to damage because very small parametric changes could cause the device not to meet its published specifications.

12.6 Glossary

[TI Glossary](#) This glossary lists and explains terms, acronyms, and definitions.

13 Mechanical, Packaging, and Orderable Information

The following pages include mechanical, packaging, and orderable information. This information is the most current data available for the designated devices. This data is subject to change without notice and revision of this document. For browser-based versions of this data sheet, refer to the left-hand navigation.

PACKAGING INFORMATION

Orderable Device	Status (1)	Package Type	Package Drawing	Pins	Package Qty	Eco Plan (2)	Lead finish/ Ball material (6)	MSL Peak Temp (3)	Op Temp (°C)	Device Marking (4/5)	Samples
TS3L501ERUAR	ACTIVE	WQFN	RUA	42	3000	RoHS & Green	NIPDAU	Level-2-260C-1 YEAR	-40 to 85	TK501E	Samples

(1) The marketing status values are defined as follows:

ACTIVE: Product device recommended for new designs.

LIFEBUY: TI has announced that the device will be discontinued, and a lifetime-buy period is in effect.

NRND: Not recommended for new designs. Device is in production to support existing customers, but TI does not recommend using this part in a new design.

PREVIEW: Device has been announced but is not in production. Samples may or may not be available.

OBSELETE: TI has discontinued the production of the device.

(2) **RoHS:** TI defines "RoHS" to mean semiconductor products that are compliant with the current EU RoHS requirements for all 10 RoHS substances, including the requirement that RoHS substance do not exceed 0.1% by weight in homogeneous materials. Where designed to be soldered at high temperatures, "RoHS" products are suitable for use in specified lead-free processes. TI may reference these types of products as "Pb-Free".

RoHS Exempt: TI defines "RoHS Exempt" to mean products that contain lead but are compliant with EU RoHS pursuant to a specific EU RoHS exemption.

Green: TI defines "Green" to mean the content of Chlorine (Cl) and Bromine (Br) based flame retardants meet JS709B low halogen requirements of <=1000ppm threshold. Antimony trioxide based flame retardants must also meet the <=1000ppm threshold requirement.

(3) MSL, Peak Temp. - The Moisture Sensitivity Level rating according to the JEDEC industry standard classifications, and peak solder temperature.

(4) There may be additional marking, which relates to the logo, the lot trace code information, or the environmental category on the device.

(5) Multiple Device Markings will be inside parentheses. Only one Device Marking contained in parentheses and separated by a "~" will appear on a device. If a line is indented then it is a continuation of the previous line and the two combined represent the entire Device Marking for that device.

(6) Lead finish/Ball material - Orderable Devices may have multiple material finish options. Finish options are separated by a vertical ruled line. Lead finish/Ball material values may wrap to two lines if the finish value exceeds the maximum column width.

Important Information and Disclaimer:The information provided on this page represents TI's knowledge and belief as of the date that it is provided. TI bases its knowledge and belief on information provided by third parties, and makes no representation or warranty as to the accuracy of such information. Efforts are underway to better integrate information from third parties. TI has taken and continues to take reasonable steps to provide representative and accurate information but may not have conducted destructive testing or chemical analysis on incoming materials and chemicals. TI and TI suppliers consider certain information to be proprietary, and thus CAS numbers and other limited information may not be available for release.

In no event shall TI's liability arising out of such information exceed the total purchase price of the TI part(s) at issue in this document sold by TI to Customer on an annual basis.

TAPE AND REEL INFORMATION

QUADRANT ASSIGNMENTS FOR PIN 1 ORIENTATION IN TAPE

*All dimensions are nominal

Device	Package Type	Package Drawing	Pins	SPQ	Reel Diameter (mm)	Reel Width W1 (mm)	A0 (mm)	B0 (mm)	K0 (mm)	P1 (mm)	W (mm)	Pin1 Quadrant
TS3L501ERUAR	WQFN	RUA	42	3000	330.0	16.4	3.8	9.3	1.0	8.0	16.0	Q1

TAPE AND REEL BOX DIMENSIONS

*All dimensions are nominal

Device	Package Type	Package Drawing	Pins	SPQ	Length (mm)	Width (mm)	Height (mm)
TS3L501ERUAR	WQFN	RUA	42	3000	367.0	367.0	38.0

GENERIC PACKAGE VIEW

RUA 42

WQFN - 0.8 mm max height

9 x 3.5, 0.5 mm pitch

PLASTIC QUAD FLATPACK - NO LEAD

This image is a representation of the package family, actual package may vary.
Refer to the product data sheet for package details.

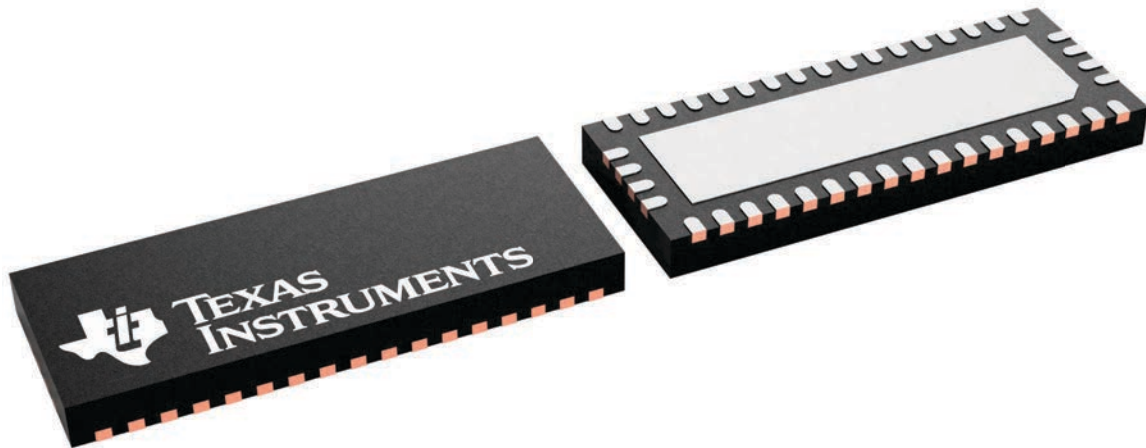

4226504/A

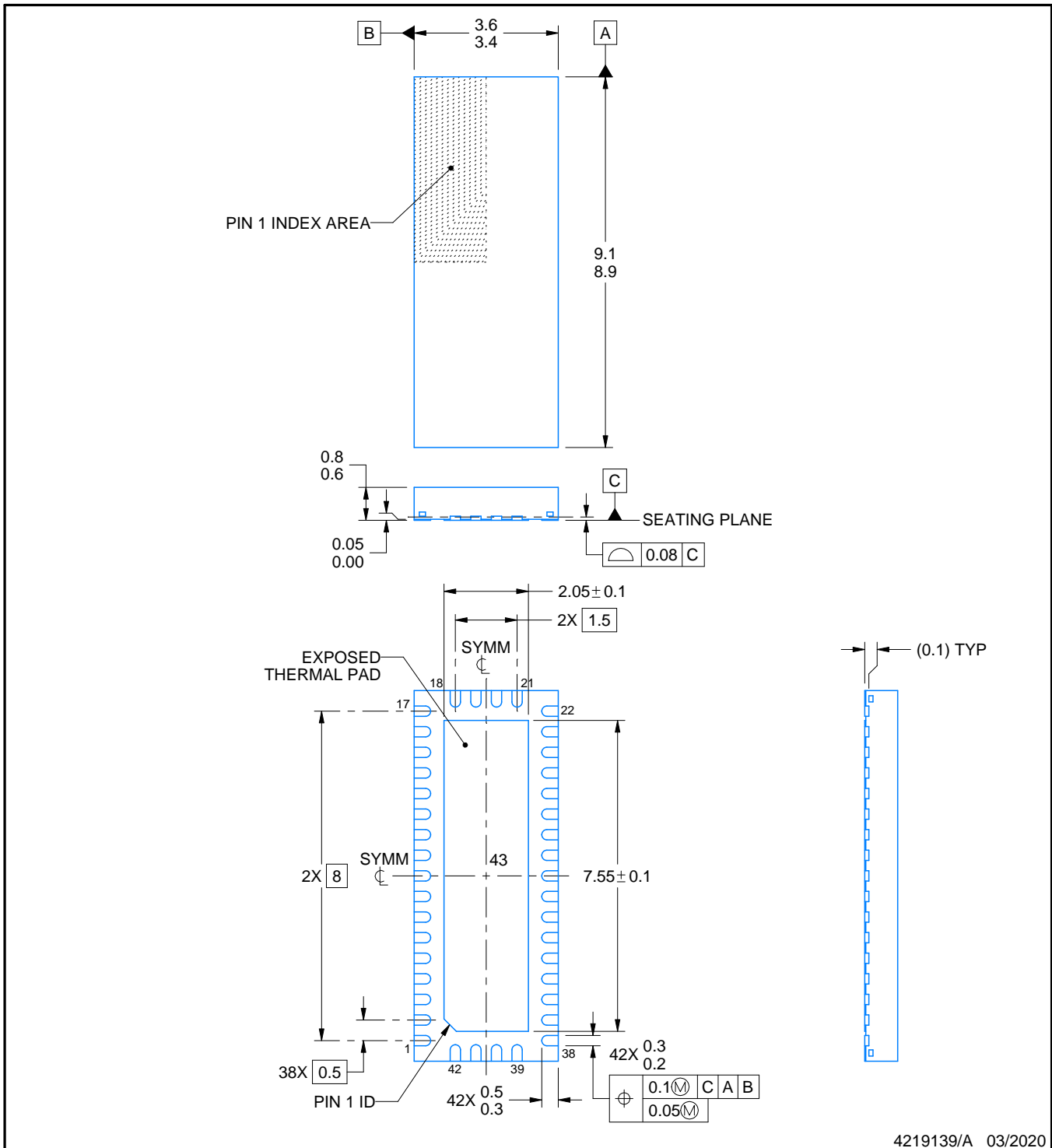

NOTES:

1. All linear dimensions are in millimeters. Any dimensions in parenthesis are for reference only. Dimensioning and tolerancing per ASME Y14.5M.
2. This drawing is subject to change without notice.
3. The package thermal pad must be soldered to the printed circuit board for thermal and mechanical performance.

EXAMPLE BOARD LAYOUT

RUA0042A

WQFN - 0.8 mm max height

PLASTIC QUAD FLATPACK - NO LEAD

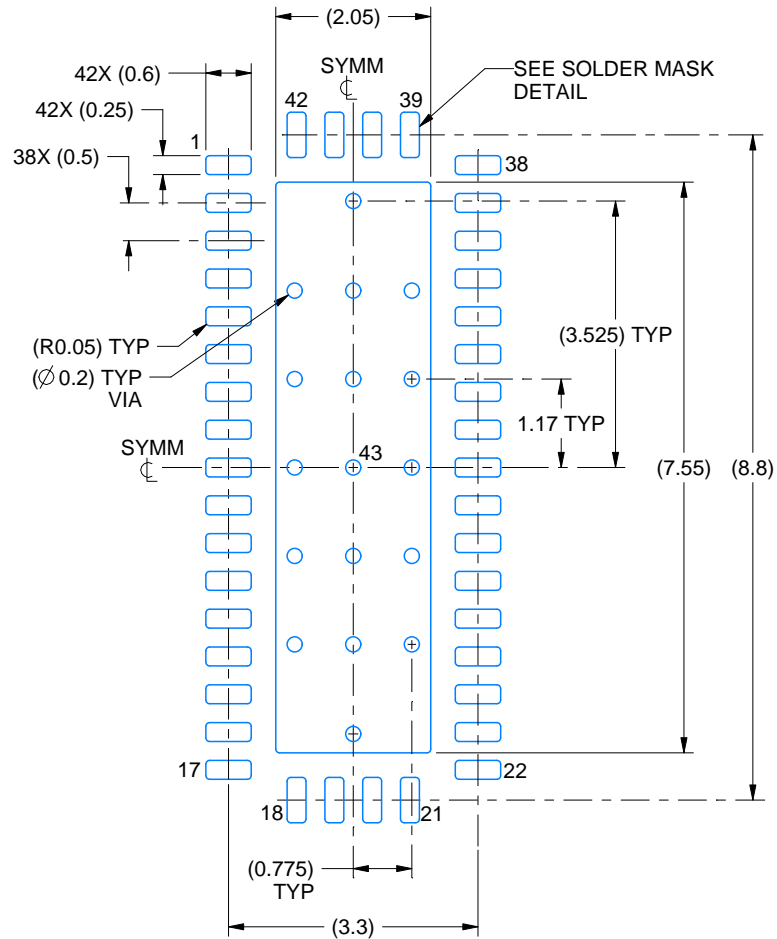

LAND PATTERN EXAMPLE
EXPOSED METAL SHOWN
SCALE: 10X

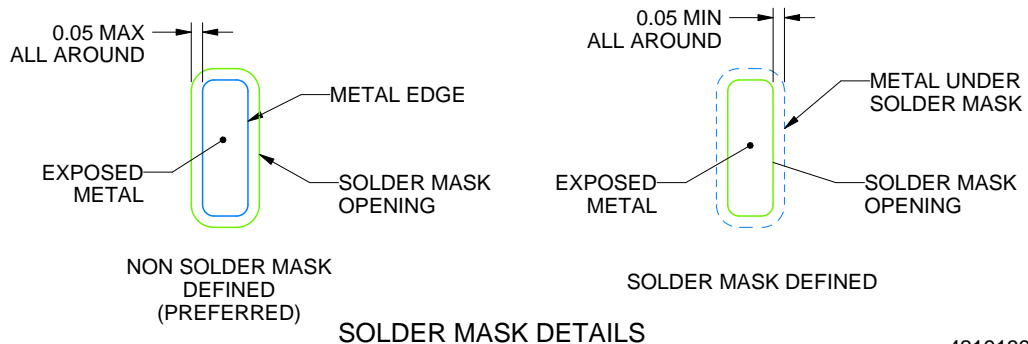

4219139/A 03/2020

NOTES: (continued)

- This package is designed to be soldered to a thermal pad on the board. For more information, see Texas Instruments literature number SLUA271 (www.ti.com/lit/slua271).
- Vias are optional depending on application, refer to device data sheet. If any vias are implemented, refer to their locations shown on this view. It is recommended that vias under paste be filled, plugged or tented.

EXAMPLE STENCIL DESIGN

RUA0042A

WQFN - 0.8 mm max height

PLASTIC QUAD FLATPACK - NO LEAD

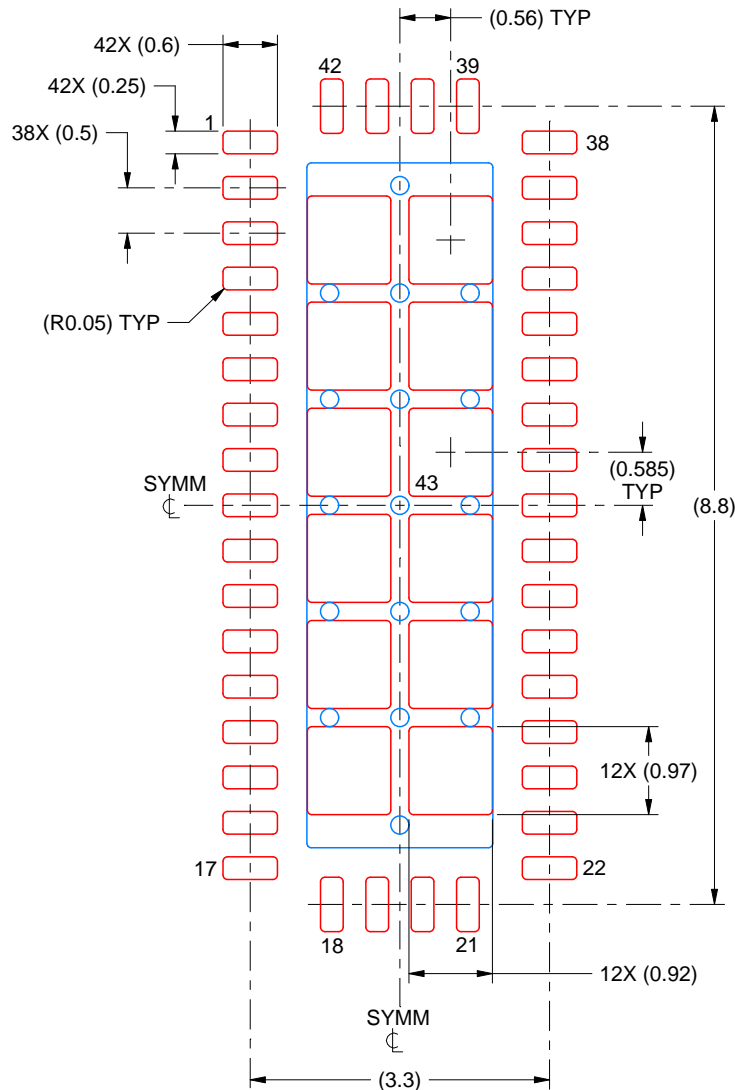

SOLDER PASTE EXAMPLE
BASED ON 0.125 MM THICK STENCIL
SCALE: 12X

EXPOSED PAD 43
69% PRINTED SOLDER COVERAGE BY AREA UNDER PACKAGE

4219139/A 03/2020

NOTES: (continued)

6. Laser cutting apertures with trapezoidal walls and rounded corners may offer better paste release. IPC-7525 may have alternate design recommendations.

重要なお知らせと免責事項

TI は、技術データと信頼性データ (データシートを含みます)、設計リソース (リファレンス・デザインを含みます)、アプリケーションや設計に関する各種アドバイス、Web ツール、安全性情報、その他のリソースを、欠陥が存在する可能性のある「現状のまま」提供しており、商品性および特定目的に対する適合性の黙示保証、第三者の知的財産権の非侵害保証を含むいかなる保証も、明示的または黙示的にかかわらず拒否します。

これらのリソースは、TI 製品を使用する設計の経験を積んだ開発者への提供を意図したものです。(1) お客様のアプリケーションに適した TI 製品の選定、(2) お客様のアプリケーションの設計、検証、試験、(3) お客様のアプリケーションに該当する各種規格や、その他のあらゆる安全性、セキュリティ、規制、または他の要件への確実な適合に関する責任を、お客様のみが単独で負うものとし、

上記の各種リソースは、予告なく変更される可能性があります。これらのリソースは、リソースで説明されている TI 製品を使用するアプリケーションの開発の目的でのみ、TI はその使用をお客様に許諾します。これらのリソースに関して、他の目的で複製することや掲載することは禁止されています。TI や第三者の知的財産権のライセンスが付与されている訳ではありません。お客様は、これらのリソースを自身で使用した結果発生するあらゆる申し立て、損害、費用、損失、責任について、TI およびその代理人を完全に補償するものとし、TI は一切の責任を拒否します。

TI の製品は、[TI の販売条件](#)、または [ti.com](https://www.ti.com) やかかる TI 製品の関連資料などのいずれかを通じて提供する適用可能な条項の下で提供されています。TI がこれらのリソースを提供することは、適用される TI の保証または他の保証の放棄の拡大や変更を意味するものではありません。

お客様がいかなる追加条項または代替条項を提案した場合でも、TI はそれらに異議を唱え、拒否します。

郵送先住所 : Texas Instruments, Post Office Box 655303, Dallas, Texas 75265
Copyright © 2023, Texas Instruments Incorporated