

TS3USBCA4 USB Type-C SBUマルチプレクサ

1 特長

- USB Type-C™ 4:1 (TS3USBCA420) および 3:1 (TS3USBCA410) マルチプレクサ (MUX) で、アナログ・オーディオ MIC/AGND、DisplayPort AUX、その他の信号用
- 0~3.6V の差動またはシングル・エンド信号用の汎用 MUX
- AGND 接続の非常に低い R_{ON} (60m Ω) による低クロストーク性能
- 低い全高調波歪み (THD)
- 最高 500MHz の広帯域幅チャンネル
- ピンと I²C の両方による構成をサポート
- 3.3V \pm 10% のレギュレートされた電源、または 2.4~5.5V バッテリでの動作をサポート
- 工業用温度範囲: -40°C~85°C (TS3USBCA420I および TS3USBCA410I)
- 商業用温度範囲: 0°C~70°C (TS3USBCA420 および TS3USBCA410)
- 1.8mm x 2.6mm、16 ピン、0.4mm ピッチの QFN パッケージ

2 アプリケーション

- タブレット
- ノートブック PC
- デスクトップ PC
- ゲーム機
- VR モジュール
- スマートフォン
- モニタ

3 概要

TS3USBCA4はパッシブ 4:1 (TS3USBCA420) および 3:1 (TS3USBCA410) の MUX で、USB Type-C コネクタの SBU1/SBU2 の端子から、各種のインターフェイスに対して、各種の差動またはシングル・エンドの信号をサポートします。差動 DisplayPort 補助 (AUX)、アナログ・オーディオ MIC および AGND、PCIe 差動クロック、またはサポートされている他の任意の一般的な差動またはシングル・エンドの信号に対応します。

オーディオ・パスはオン抵抗 (R_{ON}) が非常に低く、クロストークが低く、全高調波歪み (THD) が非常に優れています。Break-Before-Make 機能により、1 つのチャンネルから別のチャンネルに信号を転送するときの信号の歪みが防止されます。高速パスは最高 500MHz の帯域幅をサポートし、DisplayPort AUX、PCIe クロック、その他同様の信号に十分なサポートを提供します。これらの機能と、低い消費電力から、このデバイスは携帯用オーディオ・アプリケーションに適しています。

TS3USBCA4 は電源電圧範囲が 2.4V~5.5V と広く、ユーザーは単一セルのバッテリー、3.3V レギュレータ、または VBUS から柔軟に電力を供給できます。また、商業用と工業用の両方の温度範囲オプションが用意されています。

製品情報⁽¹⁾

型番	パッケージ	本体サイズ (公称)
TS3USBCA4	UQFN (16)	1.80mm x 2.60mm

(1) 利用可能なすべてのパッケージについては、このデータシートの末尾にある注文情報を参照してください。

概略回路図

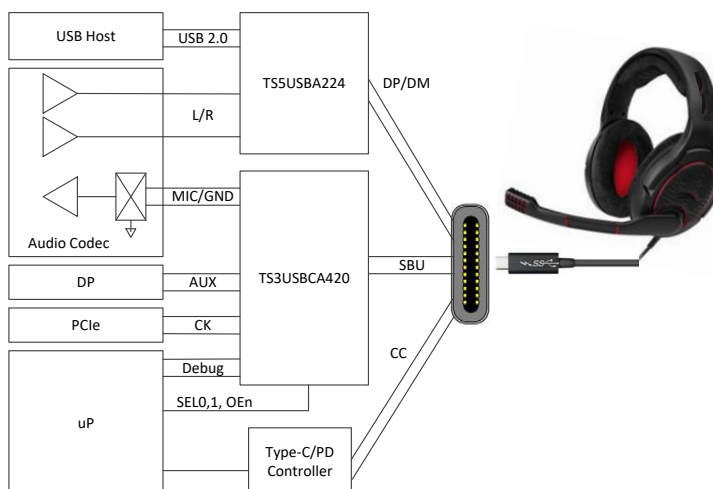

目次

1	特長	1	8.2	Functional Block Diagram	24
2	アプリケーション	1	8.3	Feature Description	25
3	概要	1	8.4	Device Functional Modes	26
4	改訂履歴	2	8.5	Programming	28
5	Pin Configuration and Functions	3	8.6	Register Maps	29
6	Specifications	4	9	Application and Implementation	31
6.1	Absolute Maximum Ratings	4	9.1	Application Information	31
6.2	ESD Ratings	4	9.2	Typical Application	31
6.3	Recommended Operating Conditions	4	10	Power Supply Recommendations	34
6.4	Thermal Information	5	11	Layout	35
6.5	Electrical Characteristics (3 V ≤ V _{CC} ≤ 3.6 V)	5	11.1	Layout Guidelines	35
6.6	Electrical Characteristics (2.4 V ≤ V _{CC} ≤ 5.5 V)	7	11.2	Layout Example	35
6.7	Switching Characteristics (2.4 V ≤ V _{CC} ≤ 5.5 V)	9	12	デバイスおよびドキュメントのサポート	36
6.8	Timing Requirements (3 V ≤ V _{CC} ≤ 3.6 V)	10	12.1	ドキュメントの更新通知を受け取る方法	36
6.9	Timing Requirements (2.4 V ≤ V _{CC} ≤ 5.5 V)	10	12.2	サポート・リソース	36
6.10	Timing Diagrams	12	12.3	商標	36
6.11	Typical Characteristics	13	12.4	静電気放電に関する注意事項	36
7	Parameter Measurement Information	14	12.5	Glossary	36
8	Detailed Description	24	13	メカニカル、パッケージ、および注文情報	36
8.1	Overview	24			

4 改訂履歴

資料番号末尾の英字は改訂を表しています。その改訂履歴は英語版に準じています。

Revision B (January 2019) から Revision C に変更	Page
• Changed description for LaAp pin From: "as a negative polarity" To "as a positive polarity".	4

Revision A (August 2018) から Revision B に変更	Page
• Changed the I2C_EN pin Description From: This pin has an internal weak pull-up. To: This pin has an internal weak pull-down.	3

2018年2月発行のものから更新	Page
• デバイスを事前情報から量産データに変更	1

5 Pin Configuration and Functions

**UQFN Package for TS3USBCA420
16-Pin (RSV)
Top View**

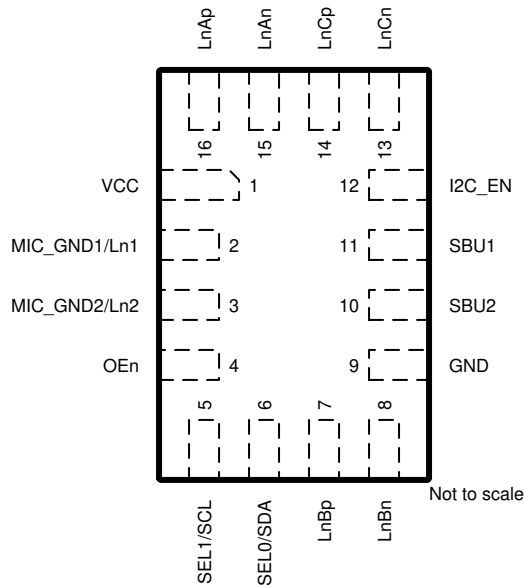

**UQFN Package for TS3USBCA410
16-Pin (RSV)
Top View**

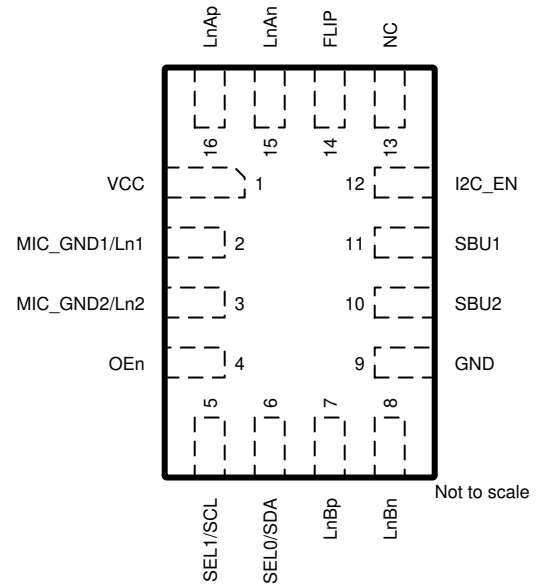

Pin Functions

NAME	PIN		I/O	DESCRIPTION
	TS3USBCA420	TS3USBCA410		
VCC	1	1	P	Power supply. External decoupling capacitors are required close to this pin.
MIC_GND1/Ln1	2	2	I/O, CMOS	Analog audio MIC/AGND signal connection to audio codec. This pin can also function as a general purpose I/O.
MIC_GND2/Ln2	3	3	I/O, CMOS	Analog audio MIC/AGND signal connection to audio codec. This pin can also function as a general purpose I/O.
OEn	4	4	2 Level I	Output Enable: L: Normal Operation H: Standby Mode, I ² C registers reset (Default) This pin has an internal weak pull-up.
SEL1/SCL	5	5	2 Level I (Failsafe)	In Pin Configuration Mode (I2C_EN = L), this pin functions as SEL1 which is used along with SEL0 pin to select switch configurations (Refer to 表 2). This pin has an internal weak pull-down. In I ² C Mode (I2C_EN = M or H), this pin functions as SCL pin for I ² C clock. When used for I ² C clock, pull it up to V _{I2C} with a resistor between 0.62 kΩ and 2.2 kΩ.
SEL0/SDA	6	6	2 Level I/O (Failsafe)	In Pin Configuration Mode (I2C_EN = L), this pin functions as SEL0 which is used along with SEL1 pin to select switch configurations (Refer to 表 2). This pin has an internal weak pull-down. In I ² C Mode (I2C_EN = M or H), this pin functions as SDA pin for I ² C data. When used for I ² C data, pull it up to V _{I2C} with a resistor between 0.62 kΩ and 2.2 kΩ.
LnBp	7	7	I/O, CMOS	This pin can be used in single-ended format or as a positive polarity differential pair partner to pin LnBn. It can be used for connection to any generic I/O signals such as for DisplayPort AUX, PCI Express clock, I ² C, UART, and debug interfaces.
LnBn	8	8	I/O, CMOS	This pin can be used in single-ended format or as a negative polarity differential pair partner to pin LnBp. It can be used for connection to any generic I/O signals such as for DisplayPort AUX, PCI Express clock, I ² C, UART, and debug interfaces.
GND	9	9	G	Primary ground connection for the TS3USBCA4. Must be connected to system ground.
SBU2	10	10	I/O, CMOS (Failsafe)	This pin should be DC coupled to the SBU2 pin of the Type-C receptacle. This pin has an internal nominally 1.6-MΩ pull-down resistor.
SBU1	11	11	I/O, CMOS (Failsafe)	This pin should be DC coupled to the SBU1 pin of the Type-C receptacle. This pin has an internal nominally 1.6-MΩ pull-down resistor.
I2C_EN	12	12	3 Level I	This pin enables I ² C Mode and sets I ² C mode addresses (Refer to 表 5) depending on the pin level defined in 表 1. L: Pin Configuration Mode M: I ² C Mode enabled with I ² C address ADDR0 H: I ² C Mode enabled with I ² C address ADDR1 This pin has an internal weak pull-down.

Pin Functions (continued)

PIN			I/O	DESCRIPTION
NAME	TS3USBCA420	TS3USBCA410		
LnCn	13		I/O, CMOS	This pin can be used in single-ended format or as a negative polarity differential pair partner to pin LnCp. It can be used for connection to any generic I/O signals such as for DisplayPort AUX, PCI Express clock, I ² C, UART, and debug interfaces.
LnCp	14		I/O, CMOS	This pin can be used in single-ended format or as a positive polarity differential pair partner to pin LnCn. It can be used for connection to any generic I/O signals such as for DisplayPort AUX, PCI Express clock, I ² C, UART, and debug interfaces.
NC		13		Not connected.
FLIP		14	I/O, CMOS	This pin flips the switches based on type-C plug orientation in pin configuration mode (I2C_EN=L). L: Normal orientation. H: Flipped orientation. This pin has an internal weak pull-down.
LnAn	15	15	I/O, CMOS	This pin can be used in single-ended format or as a negative polarity differential pair partner to pin LnAp. This pin is preferred for connection to DisplayPort AUX. It can also be used for connection to any generic I/O signals such as for PCI Express clock, I ² C, UART, and debug interfaces.
LnAp	16	16	I/O, CMOS	This pin can be used in single-ended format or as a positive polarity differential pair partner to pin LnAn. This pin is preferred for connection to DisplayPort AUX. It can also be used for connection to any generic I/O signals such as for PCI Express clock, I ² C, UART, and debug interfaces.

6 Specifications

6.1 Absolute Maximum Ratings

Over operating free-air temperature range unless otherwise noted.⁽¹⁾

		MIN	MAX	UNIT
V _{CC}	Supply Voltage Range ⁽²⁾	-0.5	6	V
V _{IN_DIFF}	Differential Voltage at Differential Inputs	-4	4	V
V _{IN_SE}	Input Voltage at Differential Inputs ⁽²⁾	-0.5	6	V
V _{IN_CMOS}	Input Voltage at CMOS Inputs other than SBU1/SBU2 Pins ⁽²⁾	-0.5	6	V
V _{IN_SBU}	Input Voltage at SBU1/SBU2 Input-output Pins ⁽²⁾	-0.5	6	V
T _J	Junction Temperature		105	°C
T _{STG}	Storage temperature	-65	150	°C

(1) Stresses beyond those listed under *Absolute Maximum Rating* may cause permanent damage to the device. These are stress ratings only, which do not imply functional operation of the device at these or any other conditions beyond those indicated under *Recommended Operating Condition*. Exposure to absolute-maximum-rated conditions for extended periods may affect device reliability.

(2) All voltage values are with respect to the GND terminal.

6.2 ESD Ratings

PARAMETER		VALUE	UNIT
V _{HBM}	Electrostatic discharge	Human body model (HBM), per ANSI/ESDA/JEDEC JS-001, all pins ⁽¹⁾	±2000 V
V _{CDM}	Electrostatic discharge	Charged device model (CDM), per JEDEC specification JESD22-C101, all pins ⁽²⁾	±500 V

(1) JEDEC document JEP155 states that 500-V HBM allows safe manufacturing with a standard ESD control process.

(2) JEDEC document JEP157 states that 250-V CDM allows safe manufacturing with a standard ESD control process.

6.3 Recommended Operating Conditions

Over operating free-air temperature range unless otherwise noted.

		MIN	NOM	MAX	UNIT
T _A	Ambient temperature for TS3USBCA410 and TS3USBCA420	0		70	°C
T _A	Ambient temperature for TS3USBCA410I and TS3USBCA420I	-40		85	°C
V _{CC}	Supply voltage	2.4	5.0	5.5	V
V _{I2C}	Supply that external resistors on SDA and SCL are pulled up too	1.7		3.6	V
V _{I/O_DIFF}	Differential Input-output Voltage	0		1.8	V
V _{PSN}	Power supply noise			100	mV

6.4 Thermal Information

THERMAL METRIC		TS3USBCA4	
		RSV (R-PUQFN-N16)	
		16 PINS	
			UNIT
$R_{\theta JA}$	Junction-to-ambient thermal resistance ⁽¹⁾	107.1	°C/W
$R_{\theta JC(top)}$	Junction-to-case (top) thermal resistance ⁽²⁾	41.2	°C/W
$R_{\theta JB}$	Junction-to-board thermal resistance ⁽³⁾	43.6	°C/W
Ψ_{JT}	Junction-to-top characterization parameter ⁽⁴⁾	1.1	°C/W
Ψ_{JB}	Junction-to-board characterization parameter ⁽⁵⁾	43.6	°C/W
$R_{\theta JC(bot)}$	Junction-to-case (bottom) thermal resistance ⁽⁶⁾	N/A	°C/W

- (1) The junction-to-ambient thermal resistance under natural convection is obtained in a simulation on a JEDEC-standard, high-K board, as specified in JESD51-7, in an environment described in JESD51-2a.
- (2) The junction-to-case (top) thermal resistance is obtained by simulating a cold plate test on the package top. No specific JEDEC standard test exists, but a close description can be found in the ANSI SEMI standard G30-88.
- (3) The junction-to-board thermal resistance is obtained by simulating in an environment with a ring cold plate fixture to control the PCB temperature, as described in JESD51-8.
- (4) The junction-to-top characterization parameter, Ψ_{JT} , estimates the junction temperature of a device in a real system and is extracted from the simulation data for obtaining θ_{JA} , using a procedure described in JESD51-2a (sections 6 and 7).
- (5) The junction-to-board characterization parameter, Ψ_{JB} , estimates the junction temperature of a device in a real system and is extracted from the simulation data for obtaining θ_{JA} , using a procedure described in JESD51-2a (sections 6 and 7).
- (6) The junction-to-case (bottom) thermal resistance is obtained by simulating a cold plate test on the exposed (power) pad. No specific JEDEC standard test exists, but a close description can be found in the ANSI SEMI standard G30-88.

6.5 Electrical Characteristics (3 V ≤ V_{CC} ≤ 3.6 V)

All minimum/maximum specifications are at T_A = -40/85°C, V_{CC} = 3.0 V/3.6 V, unless otherwise noted. Typical specifications are at T_A = 25°C, V_{CC} = 3.3 V, unless otherwise noted.

PARAMETER		TEST CONDITIONS	MIN	TYP	MAX	UNIT
Power						
I _{CC}	Supply Current	OEn = L, DEVICE_ENABLE = 1		45	70	μA
I _{OFF_I2C}	Device Shutdown Current	OEn = L, DEVICE_ENABLE = 0		17	30	μA
I _{OFF_OEN}	Device Shutdown Current	OEn = 3.6 V		0.05	3.5	μA
	Device Shutdown Current	OEn = 1.4 V		4	12	μA
SELO, SEL1						
V _{IH}	Input-high voltage		1.4			V
V _{IL}	Input-low voltage				0.4	V
I _{IH}	Input-high current	V _{IN} = V _{CC}			2.5	μA
I _{IL}	Input-low current	V _{IN} = 0 V			1	μA
R _{PD}	Pull-down resistor		1.6	3.0	5.8	MΩ
FLIP						
V _{IH}	Input-high voltage		1.4			V
V _{IL}	Input-low voltage				0.4	V
I _{IH}	Input-high current	V _{IN} = V _{CC}			2.5	μA
I _{IL}	Input-low current	V _{IN} = 0 V			1	μA
R _{PD}	Pull-down resistor		1.6	3	5.8	MΩ
OEn						
V _{IH}	Input-high voltage		1.4			V
V _{IL}	Input-low voltage				0.4	V
I _{IH}	Input-high current	V _{IN} = V _{CC}			0.6	μA
I _{IL}	Input-low current	V _{IN} = 0 V			6	μA
R _{PU}	Pull-up resistor		0.6	1.1	2.5	MΩ
I2C_EN						
V _{IH}	Input-high voltage		0.85			V _{CC}

Electrical Characteristics (3 V ≤ V_{CC} ≤ 3.6 V) (continued)

All minimum/maximum specifications are at T_A = -40/85°C, V_{CC} = 3.0 V/3.6 V, unless otherwise noted. Typical specifications are at T_A = 25°C, V_{CC} = 3.3 V, unless otherwise noted.

PARAMETER		TEST CONDITIONS	MIN	TYP	MAX	UNIT
V _{IMH}	Upper bound of mid-level input voltage. Higher input may be interpreted as logic HIGH.		0.6			V _{CC}
V _{IML}	Lower bound of mid-level input voltage. Lower input may be interpreted as logic LOW.				0.4	V _{CC}
V _{IL}	Input-low voltage				0.15	V _{CC}
I _{IH}	Input-high current				2.5	μA
I _{IM}	Mid-level input current				1.2	μA
I _{IL}	Input-low current				1	μA
R _{PD}	Pull-down resistor		1.6	3.0	5.8	MΩ
I²C Control Pins SCL, SDA						
V _{IH_I2C}	High-level input voltage	I ² C mode	1.3		V _{I2C}	V
V _{IL_I2C}	Low-level input voltage	I ² C mode	0		0.5	V
V _{OL_I2C}	Low-level output voltage	I ² C mode; I _{OL_I2C} = 3 mA	0		0.4	V
I _{OL_I2C}	Low-level output current	I ² C mode; V _{OL_I2C} = 0.4 V	6			mA
I _{I_I2C}	Input current on SDA pin	0.1*V _{I2C} < Input voltage < 3.6 V	-5		5	μA
C _{I_I2C}	Input capacitance		0.5		10	pF
C _(I2C_FM_BUS)	I ² C bus capacitance for FM (400 kHz)				150	pF
R _(EXT_I2C_FM)	External pull up resistors on both SDA and SCL for FM (400 kHz)	C _(I2C_FM_BUS) = 150 pF	620	1500	2200	Ω
SBU1, SBU2						
C _{SBU_HS}	Single-ended capacitance at 500MHz looking into SBU pin	V _{IN} = 0 V, outputs open, high-speed path enabled	4	11	13	pF
C _{SBU_AU_DIO}	Single-ended capacitance at 500MHz looking into SBU pin	V _{IN} = 0 V, outputs open, audio path enabled; T _A = 25°C; V _{CC} = 3.3 V	8	10	14	pF
C _{SBU_OFF}	Single-ended capacitance at 500MHz looking into SBU pin	V _{IN} = 0 V, outputs open, OEn=H; T _A = 25°C; V _{CC} = 3.3 V	11	14	17	pF
R _{PD}	Pull-down resistor		0.8	1.6	3.3	MΩ
LnA, LnB, LnC: HIGH-SPEED PATH						
V _{I_HS}	Single-ended HS input voltage		-0.3		3.6	V
C _{HS_ON}	Single-ended capacitance at 500 MHz looking into HS pins	V _{IN} = 0 V, outputs open, high-speed path enabled		8.5	10.5	pF
C _{HS_AUDIO}	Single-ended capacitance at 500 MHz looking into HS pins	V _{IN} = 0 V, outputs open, audio path enabled; T _A = 25°C; V _{CC} = 3.3 V		1.7	2	pF
C _{HS_OFF}	Single-ended capacitance at 500 MHz looking into HS pins	V _{IN} = 0 V, outputs open, OEn=H; T _A = 25°C; V _{CC} = 3.3 V		1.7	2	pF
R _{ON_HS}	ON resistance	V _{IN} = 0 V, I _O = -40 mA		4.9	7.1	Ω
ΔR _{ON_HS}	ON resistance match between pairs of the same channel	V _{IN} ≤ 0 V, I _O = -40 mA			0.5	Ω
R _{ON_FLAT_HS}	ON resistance flatness (R _{ON_HS(MAX)} - R _{ON_HS(MIN)})	0 V ≤ V _{IN} ≤ 3.6 V, I _O = -40 mA		1.35		Ω
BW _{HS}	-3-dB bandwidth	R _L = 50 Ω, V _{IN} = 0 V, MIC_GND1 pin open, MIC_GND1 pin open; T _A = 25°C; V _{CC} = 3.3 V	460	510	550	MHz
RJ _{HS}	Additive random jitter	R _L = 50 Ω, 10 kHz to 20 MHz offset, f = 100 MHz; T _A = 25°C; V _{CC} = 3.3 V		0.012		ps-RMS
MIC_GND1, MIC_GND2: AUDIO PATH						
V _{I_MIC}	MIC input voltage		-0.3		3.6	V

Electrical Characteristics (3 V ≤ V_{CC} ≤ 3.6 V) (continued)

All minimum/maximum specifications are at T_A = -40/85°C, V_{CC} = 3.0 V/3.6 V, unless otherwise noted. Typical specifications are at T_A = 25°C, V_{CC} = 3.3 V, unless otherwise noted.

PARAMETER		TEST CONDITIONS	MIN	TYP	MAX	UNIT
C _{AUDIO_ON}	Single-ended capacitance at 500MHz looking into the MIC_GND pins	V _{IN} = 0 V, outputs open, audio path enabled; T _A = 25°C; V _{CC} = 3.3 V		9.5	12	pF
C _{AUDIO_HS}	Single-ended capacitance at 500MHz looking into the MIC_GND pins	V _{IN} = 0 V, outputs open, high-speed path enabled; T _A = 25°C; V _{CC} = 3.3 V		11.5	16	pF
C _{AUDIO_OFF}	Single-ended capacitance at 500MHz looking into the MIC_GND pins	V _{IN} = 0 V, outputs open, OEn=H; T _A = 25°C; V _{CC} = 3.3 V		12.5	14.5	pF
R _{ON_AUDIO}	ON resistance for AUDIO path	V _{IN} = 0 V, I _O = -75 mA		50	80	mΩ
BW _{AUDIO}	-3-dB bandwidth	R _L = 50 Ω, V _{IN} = 0 V; T _A = 25°C; V _{CC} = 3.3 V	580	630	700	MHz
PSR ₂₁₇	Power supply rejection	R _L = 50 Ω, V _{IN} = 3.3 V ± 200 mV _{PP} , f = 217 Hz		-105	-100	dB
PSR _{1K}		R _L = 50 Ω, V _{IN} = 3.3 V ± 200 mV _{PP} , f = 1 kHz		-96	-92	dB
PSR _{20K}		R _L = 50 Ω, V _{IN} = 3.3 V ± 200 mV _{PP} , f = 20 kHz		-85	-81	dB
THD _{200_MIC}	Total harmonic distortion	R _S =600Ω, R _L =600Ω, V _{IN} =1.8V±200mV _{PP} , f=20Hz~20kHz; T _A = 25°C; V _{CC} = 3.3 V		0.006		%
THD _{500_MIC}	Total harmonic distortion	R _S =600Ω, R _L =600Ω, V _{IN} =1.8V±500mV _{PP} , f=20Hz~20kHz; T _A = 25°C; V _{CC} = 3.3 V		0.003		%
X _{TALK_MICGND}	Crosstalk between MIC and AGND	V _{IN} = 200 mV _{PP} , f = 20 Hz – 20 kHz, R _L = 50 Ω; T _A = 25°C;		-110	-90	dB
ISO _{OFF_MICGND}	OFF isolation	V _{IN} = 200 mV _{PP} , f = 20 Hz – 20 kHz, R _L = 50 Ω; T _A = 25°C;		-73	-67	dB

6.6 Electrical Characteristics (2.4 V ≤ V_{CC} ≤ 5.5 V)

All minimum/maximum specifications are at T_A = -40/85°C, V_{CC} = 2.4 V/5.5 V, unless otherwise noted. Typical specifications are at T_A = 25°C, V_{CC} = 3.3 V, unless otherwise noted.

PARAMETER		TEST CONDITIONS	MIN	TYP	MAX	UNIT
Power						
I _{CC}	Supply Current	OEn = L, DEVICE_ENABLE = 1		45	75	μA
I _{OFF_I2C}	Device Shutdown Current	OEn = L, DEVICE_ENABLE = 0		17	40	μA
I _{OFF_OEN}	Device Shutdown Current	OEn = 3.6 V		0.05	5.5	μA
	Device Shutdown Current	OEn = 1.4 V		4	80	μA
SELO, SEL1						
V _{IH}	Input-high voltage		1.4			V
V _{IL}	Input-low voltage				0.4	V
I _{IH}	Input-high current	V _{IN} = V _{CC}			3.5	μA
I _{IL}	Input-low current	V _{IN} = 0 V			1	μA
R _{PD}	Pull-down resistor		1.6	3.0	5.8	MΩ
FLIP						
V _{IH}	Input-high voltage		1.4			V
V _{IL}	Input-low voltage				0.4	V
I _{IH}	Input-high current	V _{IN} = V _{CC}			3.5	μA
I _{IL}	Input-low current	V _{IN} = 0 V			1	μA
R _{PD}	Pull-down resistor		1.6	3.0	5.8	MΩ
OEn						
V _{IH}	Input-high voltage		1.5			V

Electrical Characteristics (2.4 V ≤ V_{CC} ≤ 5.5 V) (continued)

All minimum/maximum specifications are at T_A = -40/85°C, V_{CC} = 2.4 V/5.5 V, unless otherwise noted. Typical specifications are at T_A = 25°C, V_{CC} = 3.3 V, unless otherwise noted.

PARAMETER		TEST CONDITIONS	MIN	TYP	MAX	UNIT
V _{IL}	Input-low voltage				0.4	V
I _{IH}	Input-high current	V _{IN} =V _{CC}			1	μA
I _{IL}	Input-low current	V _{IN} =0 V			8	μA
R _{PU}	Pull-up resistor		0.6	1.1	2.5	MΩ
I2C_EN						
V _{IH}	Input-high voltage		0.9			V _{CC}
V _{IMH}	Upper bound of mid-level input voltage. Higher input may be interpreted as logic HIGH.		0.58			V _{CC}
V _{IML}	Lower bound of mid-level input voltage. Lower input may be interpreted as logic LOW.				0.42	V _{CC}
V _{IL}	Input-low voltage				0.14	V _{CC}
I _{IH}	Input-high current				3.5	μA
I _{IM}	Mid-level input current				1.6	μA
I _{IL}	Input-low current				1	μA
R _{PD}	Pull-down resistor		1.6	3.0	5.8	MΩ
I²C Control Pins SCL, SDA						
V _{IH_I2C}	High-level input voltage	I ² C mode	1.3		V _{I2C}	V
V _{IL_I2C}	Low-level input voltage	I ² C mode	0		0.5	V
V _{OL_I2C}	Low-level output voltage	I ² C mode; I _{OL_I2C} = 3 mA	0		0.4	V
I _{OL_I2C}	Low-level output current	I ² C mode; V _{OL_I2C} = 0.4 V	4			mA
I _{I_I2C}	Input current on SDA pin	0.1 * V _{I2C} < Input voltage < 3.6 V	-5		5	μA
C _{I_I2C}	Input capacitance		0.5		10	pF
C _(I2C_FM_BUS)	I ² C bus capacitance for FM (400 kHz)				150	pF
R _(EXT_I2C_FM)	External pull up resistors on both SDA and SCL for FM (400 kHz)	C _(I2C_FM_BUS) = 150 pF	620	1500	2200	Ω
SBU1, SBU2						
C _{SBU_HS}	Single-ended capacitance at 500MHz looking into SBU pin	V _{IN} = 0 V, outputs open, high-speed path enabled	4	11	13	pF
C _{SBU_AU_DIO}	Single-ended capacitance at 500MHz looking into SBU pin	V _{IN} = 0 V, outputs open, audio path enabled; T _A = 25°C; V _{CC} = 3.3 V	8	10	14	pF
C _{SBU_OFF}	Single-ended capacitance at 500MHz looking into SBU pin	V _{IN} = 0 V, outputs open, OEn=H; T _A = 25°C; V _{CC} = 3.3 V	11	14	17	pF
R _{PD}	Pull-down resistor		0.8	1.6	3.3	MΩ
LnA, LnB, LnC: HIGH-SPEED PATH						
V _{I_HS}	Single-ended HS input voltage		-0.3		3.6	V
C _{HS_ON}	Single-ended capacitance at 500 MHz looking into HS pins	V _{IN} = 0 V, outputs open, high-speed path enabled		8.5	10.5	pF
C _{HS_AUDI_O}	Single-ended capacitance at 500 MHz looking into HS pins	V _{IN} = 0 V, outputs open, audio path enabled; T _A = 25°C; V _{CC} = 3.3 V		1.7	2	pF
C _{HS_OFF}	Single-ended capacitance at 500 MHz looking into HS pins	V _{IN} = 0 V, outputs open, OEn=H; T _A = 25°C; V _{CC} = 3.3 V		1.7	2	pF
R _{ON_HS}	ON resistance	V _{IN} = 0 V, I _O = -40 mA		4.9	7.5	Ω
ΔR _{ON_HS}	ON resistance match between pairs of the same channel	V _{IN} ≤ 0 V, I _O = -40 mA			0.65	Ω
R _{ON_FLAT_HS}	ON resistance flatness (R _{ON_HS(MAX)} - R _{ON_HS(MIN)})	0 V ≤ V _{IN} ≤ 3.6 V, I _O = -40 mA		1.35		Ω

Electrical Characteristics (2.4 V ≤ V_{CC} ≤ 5.5 V) (continued)

All minimum/maximum specifications are at T_A = -40/85°C, V_{CC} = 2.4 V/5.5 V, unless otherwise noted. Typical specifications are at T_A = 25°C, V_{CC} = 3.3 V, unless otherwise noted.

PARAMETER		TEST CONDITIONS	MIN	TYP	MAX	UNIT
BW _{HS}	-3-dB bandwidth	R _L = 50 Ω, V _{IN} = 0 V; T _A = 25°C; V _{CC} = 3.3 V	450	510	670	MHz
RJ _{HS}	Additive random jitter	R _L = 50 Ω, 10 kHz to 20 MHz offset, f = 100 MHz; T _A = 25°C; V _{CC} = 3.3 V		0.012		ps-RMS
MIC_GND1, MIC_GND2: AUDIO PATH						
V _{I_MIC}	MIC input voltage		-0.3		3.6	V
C _{AUDIO_ON}	Single-ended capacitance at 500MHz looking into the MIC_GND pins	V _{IN} = 0 V, outputs open, audio path enabled; T _A = 25°C; V _{CC} = 3.3 V		9.5	12	pF
C _{AUDIO_HS}	Single-ended capacitance at 500MHz looking into the MIC_GND pins	V _{IN} = 0 V, outputs open, high-speed path enabled; T _A = 25°C; V _{CC} = 3.3 V		11.5	16	pF
C _{AUDIO_OFF}	Single-ended capacitance at 500MHz looking into the MIC_GND pins	V _{IN} = 0 V, outputs open, OEN=H; T _A = 25°C; V _{CC} = 3.3 V		12.5	14.5	pF
R _{ON_AUDIO}	ON resistance for AUDIO path	V _{IN} = 0 V, I _O = -75 mA		50	80	mΩ
BW _{AUDIO}	-3-dB bandwidth	R _L = 50 Ω, V _{IN} = 0 V; T _A = 25°C; V _{CC} = 3.3 V	580	630	720	MHz
PSR ₂₁₇	Power supply rejection	R _L = 50 Ω, V _{IN} = 3.3 V ± 200 mV _{PP} , f = 217 Hz		-105	-96	dB
PSR _{1K}		R _L = 50 Ω, V _{IN} = 3.3 V ± 200 mV _{PP} , f = 1 kHz		-96	-90	dB
PSR _{20K}		R _L = 50 Ω, V _{IN} = 3.3 V ± 200 mV _{PP} , f = 20 kHz		-85	-81	dB
THD _{200_MIC}	Total harmonic distortion	R _S =600Ω, R _L =600Ω, V _{IN} =1.8V±200mV _{PP} , f=20Hz~20kHz; T _A = 25°C; V _{CC} = 3.3 V		0.006		%
THD _{500_MIC}	Total harmonic distortion	R _S =600Ω, R _L =600Ω, V _{IN} =1.8V±500mV _{PP} , f=20Hz~20kHz; T _A = 25°C; V _{CC} = 3.3 V		0.003		%
X _{TALK_MICGND}	Crosstalk between MIC and AGND	V _{IN} = 200 mV _{PP} , f = 20 Hz – 20 kHz, R _L = 50 Ω; T _A = 25°C;		-110	-90	dB
ISO _{OFF_MICGND}	OFF isolation	V _{IN} = 200 mV _{PP} , f = 20 Hz – 20 kHz, R _L = 50 Ω; T _A = 25°C;		-73	-67	dB

6.7 Switching Characteristics (2.4 V ≤ V_{CC} ≤ 5.5 V)

All minimum/maximum specifications are at T_A = -40/85°C, V_{CC} = 2.4 V/5.5 V, unless otherwise noted. Typical specifications are at T_A = 25°C, V_{CC} = 3.3 V, unless otherwise noted.

PARAMETER		TEST CONDITIONS	MIN	TYP	MAX	UNIT
I2C						
f _{SCL}	I2C clock frequency				400	kHz
t _{BUF}	Bus free time between START and STOP conditions		1.3			μs
t _{HDSTA}	Hold time after repeated START condition. After this period, the first clock pulse is generated		0.6			μs
t _{LOW}	Low period of the I2C clock		1.3			μs
t _{HIGH}	High period of the I2C clock		0.6			μs
t _{SUSTA}	Setup time for a repeated START condition		0.6			μs
t _{HDDAT}	Data hold time		0			μs
t _{SUDAT}	Data setup time		150			ns
t _R	Rise time of both SDA and SCL signals				300	ns

Switching Characteristics (2.4 V ≤ V_{CC} ≤ 5.5 V) (continued)

All minimum/maximum specifications are at T_A = -40/85°C, V_{CC} = 2.4 V/5.5 V, unless otherwise noted. Typical specifications are at T_A = 25°C, V_{CC} = 3.3 V, unless otherwise noted.

PARAMETER	TEST CONDITIONS	MIN	TYP	MAX	UNIT
t _F	Fall time of both SDA and SCL signals	20 × (V _{I2C} /5.5 V)		300	ns
t _{SUSTO}	Setup time for STOP condition	0.6			μs

6.8 Timing Requirements (3 V ≤ V_{CC} ≤ 3.6 V)

All minimum/maximum specifications are at T_A = -40/85°C, V_{CC} = 3.0 V/3.6 V, unless otherwise noted. Typical specifications are at T_A = 25°C, V_{CC} = 3.3 V, unless otherwise noted.

	TEST CONDITIONS	MIN	NOM	MAX	UNIT
t _{ON_MICG} ND	Switch ON time for MIC/AGND path V _{PU} =1.8V, R _{PU} =2100Ω, C _L =50pF			10	μs
t _{OFF_MICG} ND	Switch OFF time for MIC/AGND path V _{PU} =1.8V, R _{PU} =2100Ω, C _L =50pF			5	μs
t _{ON_HS}	Switch ON time for high-speed path R _S =50Ω, R _L =50Ω			1.1	μs
t _{OFF_HS}	Switch OFF time for high-speed path R _S =50Ω, R _L =50Ω			725	ns
t _{BBM}	Break before make off time for MIC/AGND path V _{PU} =1.8V, R _{PU} =2100Ω, R _L =50Ω, C _L =50pF	1300			ns
t _{FLIP}	Response time for the FLIP pin R _S =50Ω, R _L =50Ω			1	μs
t _{DEV_ENA} BLE	Device enable time from OEn = L to device ready OEn=L			350	μs
t _{DEV_DISA} BLE	Device disable time from OEn = H to device shutdown OEn=H			175	ns
t _{D_PG}	V _{CC} (MIN) to Internal Power Good asserted high (Refer to 1) OEn=L			250	μs
t _{CFG_DB}	Debounce time for SEL[1:0] and I2C_EN configuration pins (Refer to 1) OEn=L	150			ns
t _{VCC_RAM} P	V _{CC} power supply (0 – 100%) ramp time requirement (Refer to 1)	0.1		100	ms

6.9 Timing Requirements (2.4 V ≤ V_{CC} ≤ 5.5 V)

All minimum/maximum specifications are at T_A = -40/85°C, V_{CC} = 2.4 V/5.5 V, unless otherwise noted. Typical specifications are at T_A = 25°C, V_{CC} = 3.3 V, unless otherwise noted.

	TEST CONDITIONS	MIN	NOM	MAX	UNIT
t _{ON_MICG} ND	Switch ON time for MIC/AGND path V _{PU} =1.8V, R _{PU} =2100Ω, C _L =50pF			12	μs
t _{OFF_MICG} ND	Switch OFF time for MIC/AGND path V _{PU} =1.8V, R _{PU} =2100Ω, C _L =50pF			6	μs
t _{ON_HS}	Switch ON time for high-speed path R _S =50Ω, R _L =50Ω			1.2	μs
t _{OFF_HS}	Switch OFF time for high-speed path R _S =50Ω, R _L =50Ω			780	ns
t _{BBM}	Break before make off time for MIC/AGND path V _{PU} =1.8V, R _{PU} =2100Ω, R _L =50Ω, C _L =50pF	1300			ns
t _{FLIP}	Response time for the FLIP pin R _S =50Ω, R _L =50Ω			1.1	μs
t _{DEV_ENA} BLE	Device enable time from OEn = L to device ready OEn=L			450	μs

Timing Requirements (2.4 V ≤ V_{CC} ≤ 5.5 V) (continued)

All minimum/maximum specifications are at T_A = -40/85°C, V_{CC} = 2.4 V/5.5 V, unless otherwise noted. Typical specifications are at T_A = 25°C, V_{CC} = 3.3 V, unless otherwise noted.

		TEST CONDITIONS	MIN	NOM	MAX	UNIT
t _{DEV_DISABLE}	Device disable time from OEn = H to device shutdown	OEn=H			200	ns
t _{D_PG}	V _{CC (MIN)} to Internal Power Good asserted high (Refer to 1)	OEn=L			250	μs
t _{CFG_DB}	Debounce time for SEL[1:0] and I2C_EN configuration pins (Refer to 1)	OEn=L	140			ns
t _{VCC_RAM P}	V _{CC} power supply (0 – 100%) ramp time requirement (Refer to 1)		0.1		100	ms

6.10 Timing Diagrams



图 1. Power-Up Timing



图 2. I²C Timing Diagram Definitions

6.11 Typical Characteristics

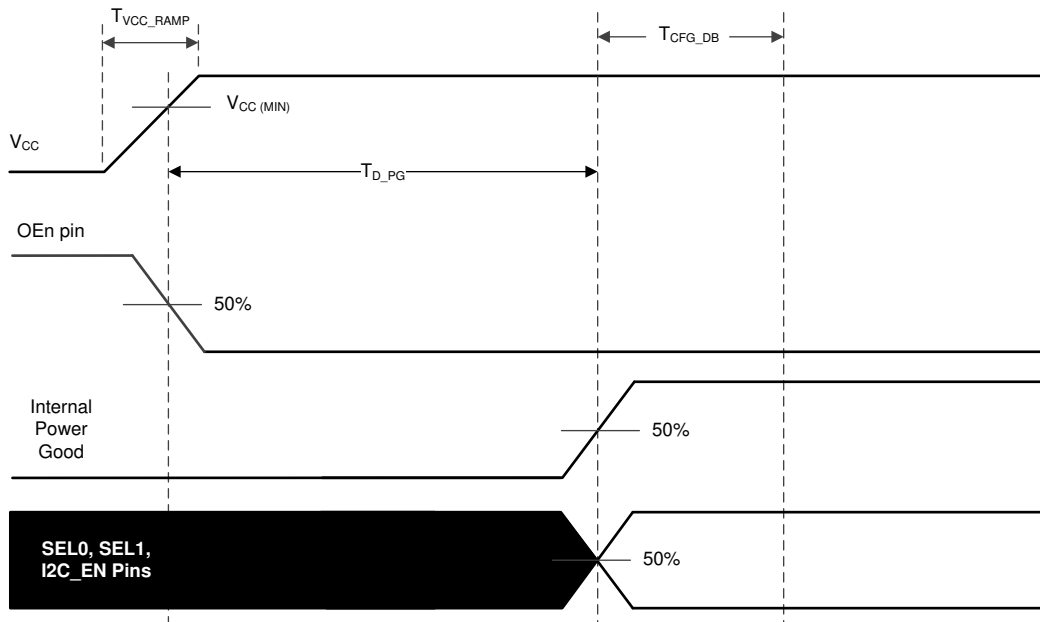

图 3. S3PX Total Harmonic Distortion

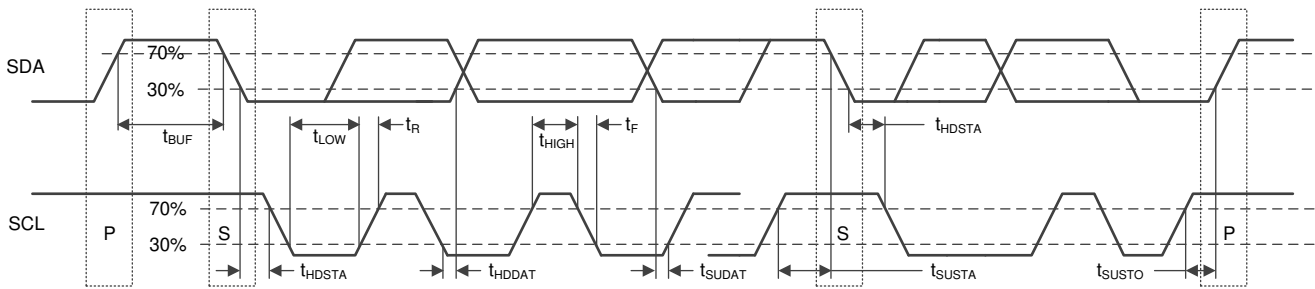

图 4. Off Isolation

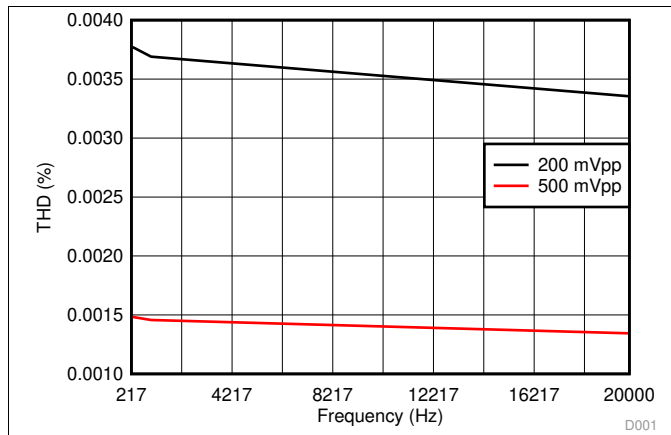

图 5. Power Supply Rejection

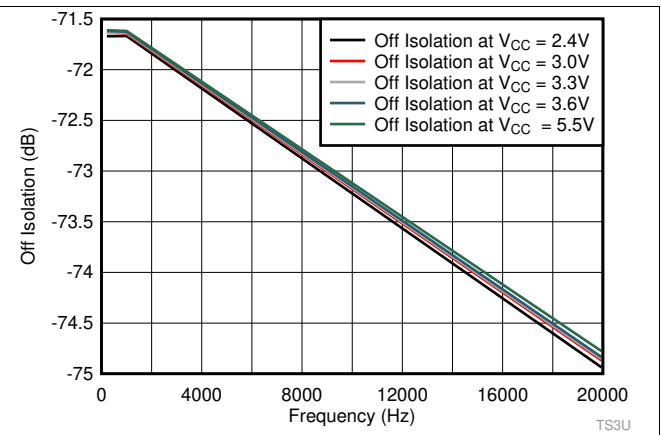

图 6. Crosstalk

7 Parameter Measurement Information

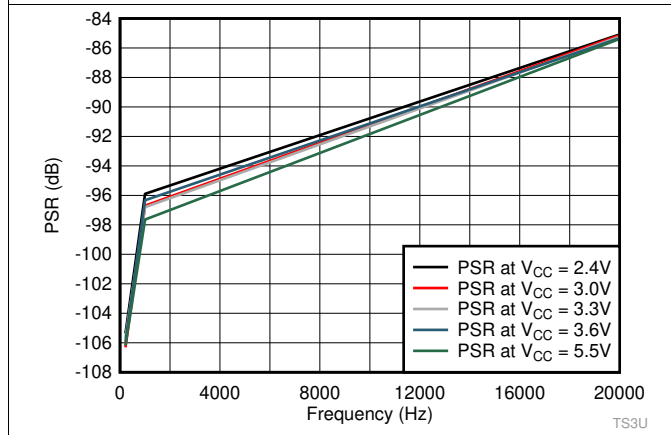

Copyright © 2018, Texas Instruments Incorporated

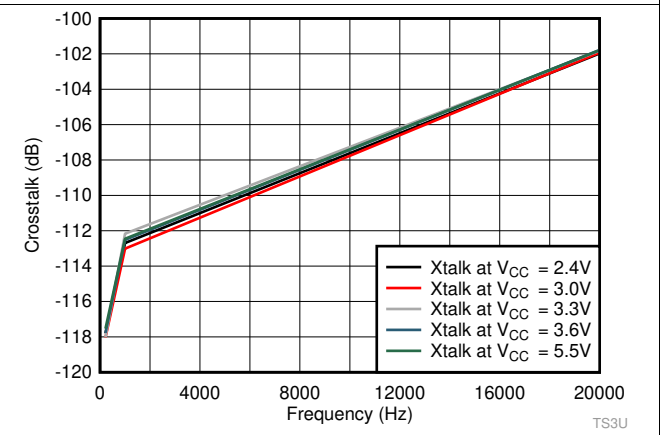
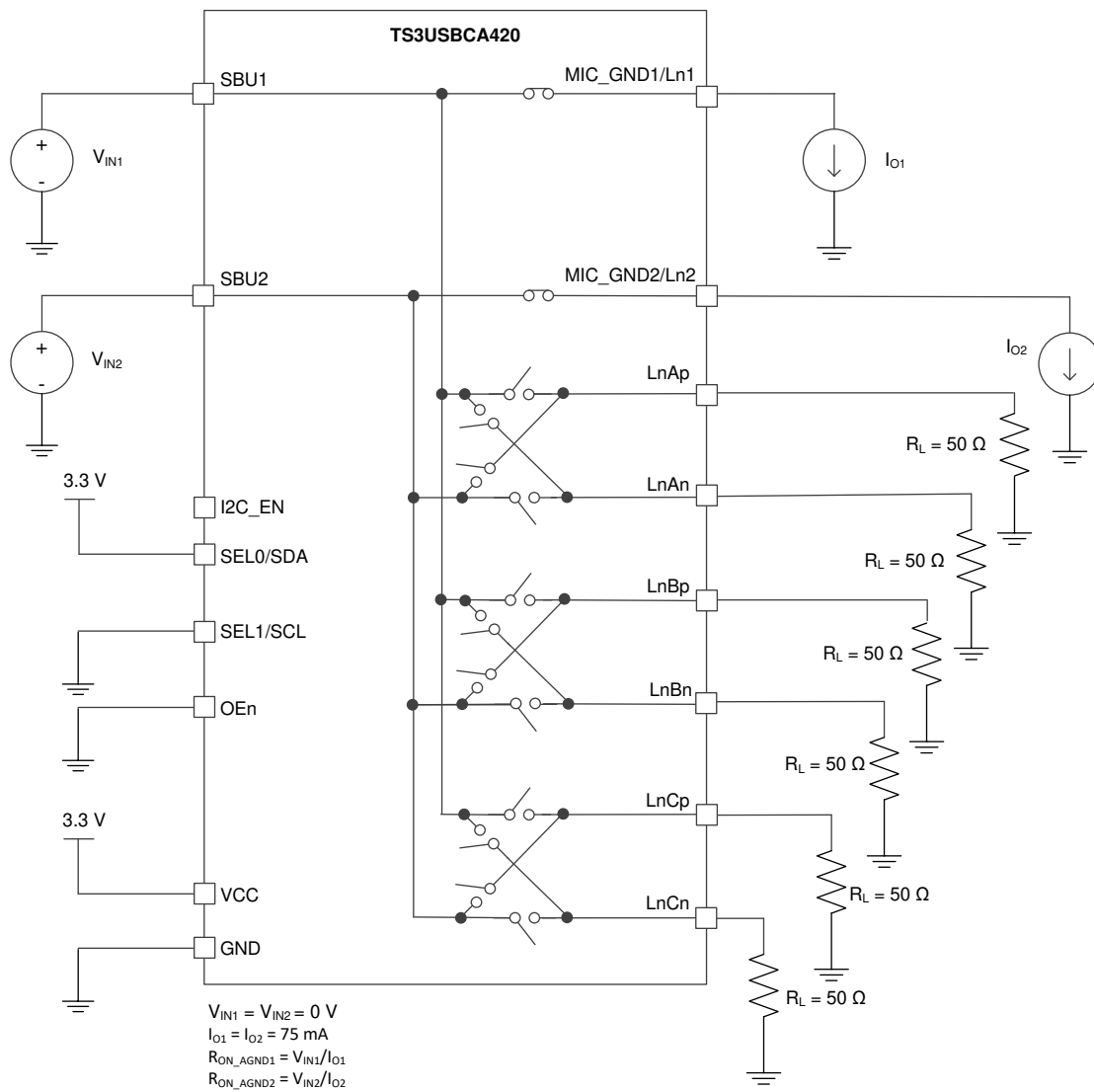
7. ON-State Resistance for the Analog Audio GND (R_{ON_AGND})

Parameter Measurement Information (continued)

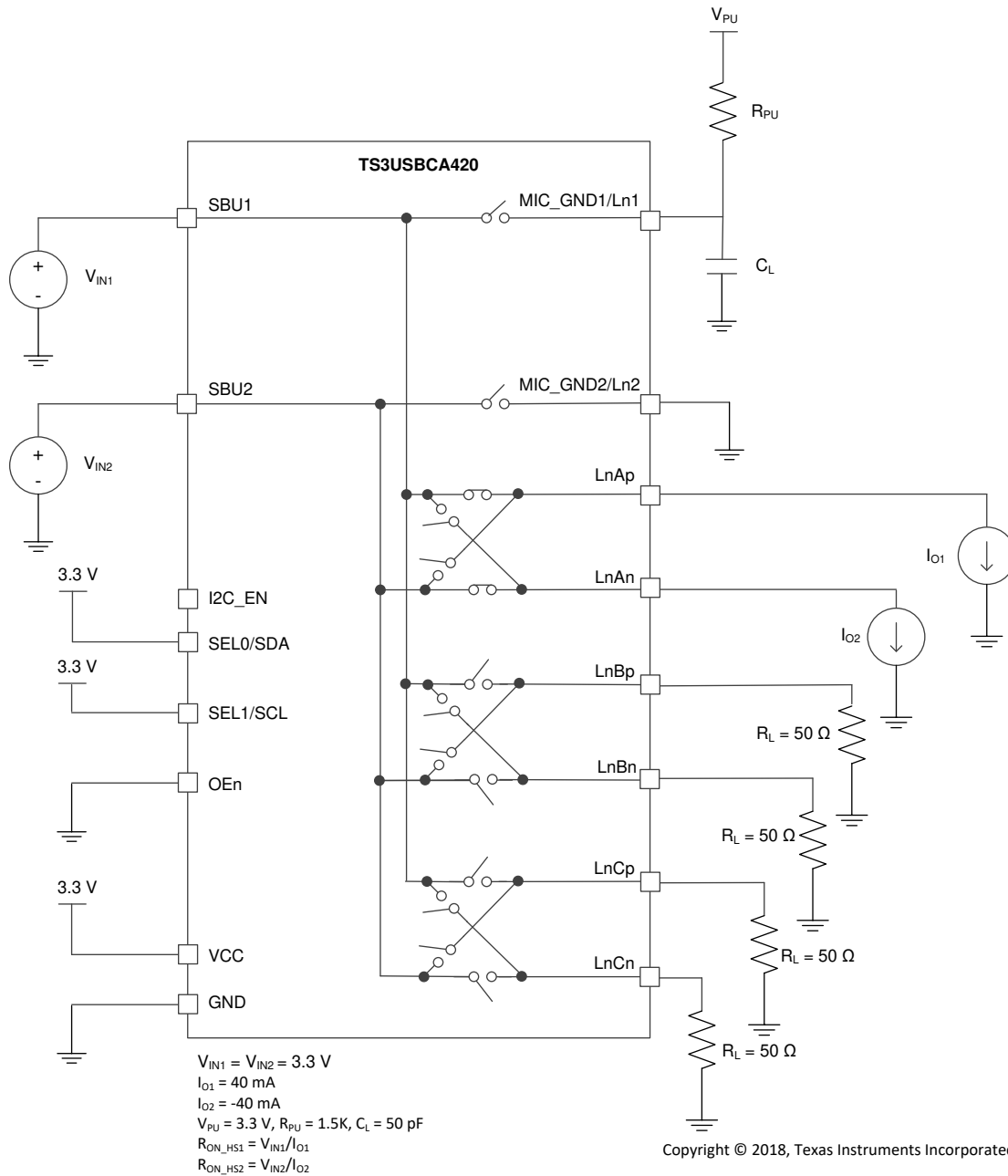

8. ON-State Resistance for High-Speed Data Paths (R_{ON_HS})

Parameter Measurement Information (continued)



图 9. ON-State and OFF-State Output Capacitance for High-Speed Data Paths ($C_{\text{ON_HS}}$, $C_{\text{OFF_HS}}$)

Parameter Measurement Information (continued)

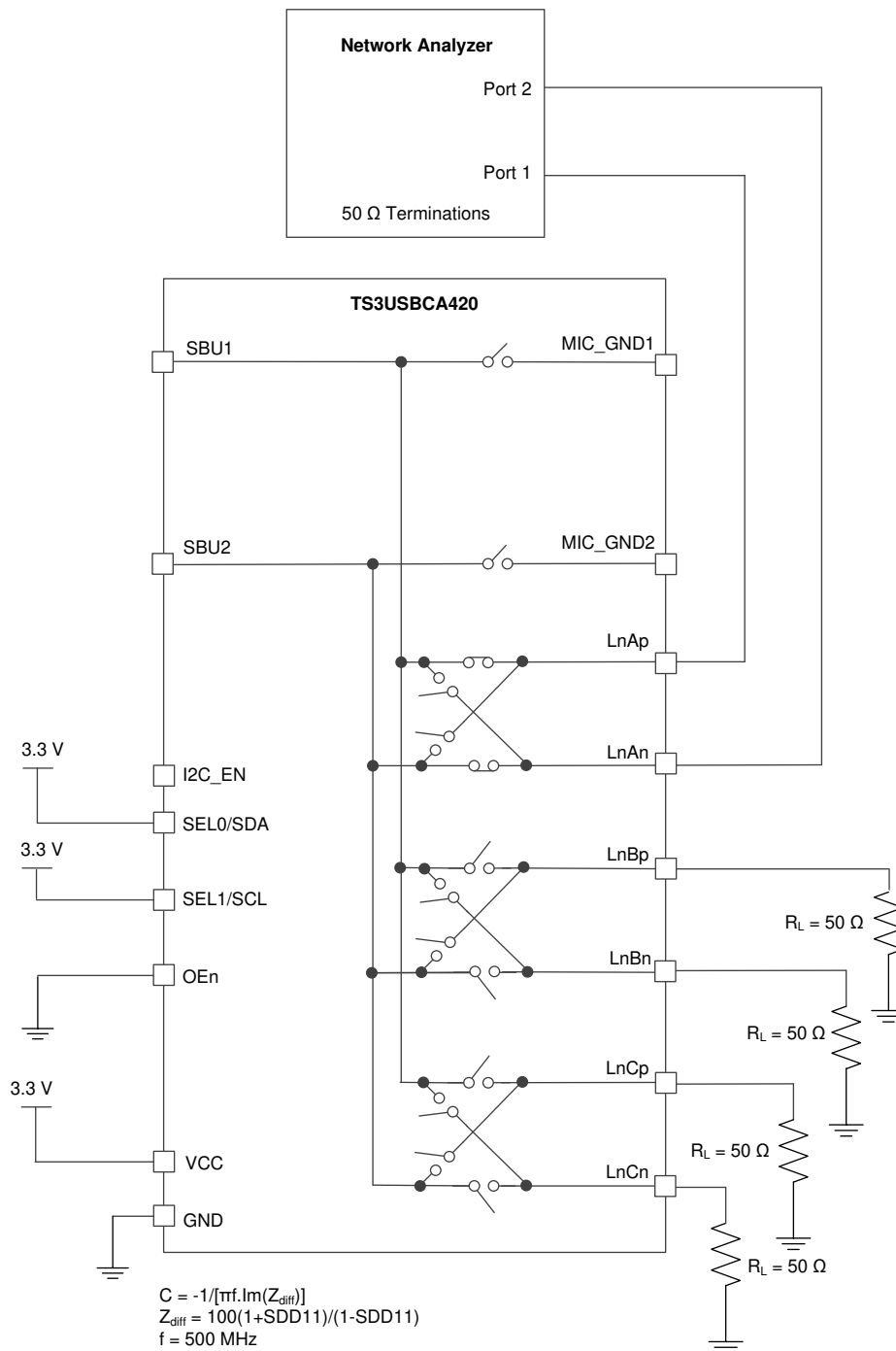
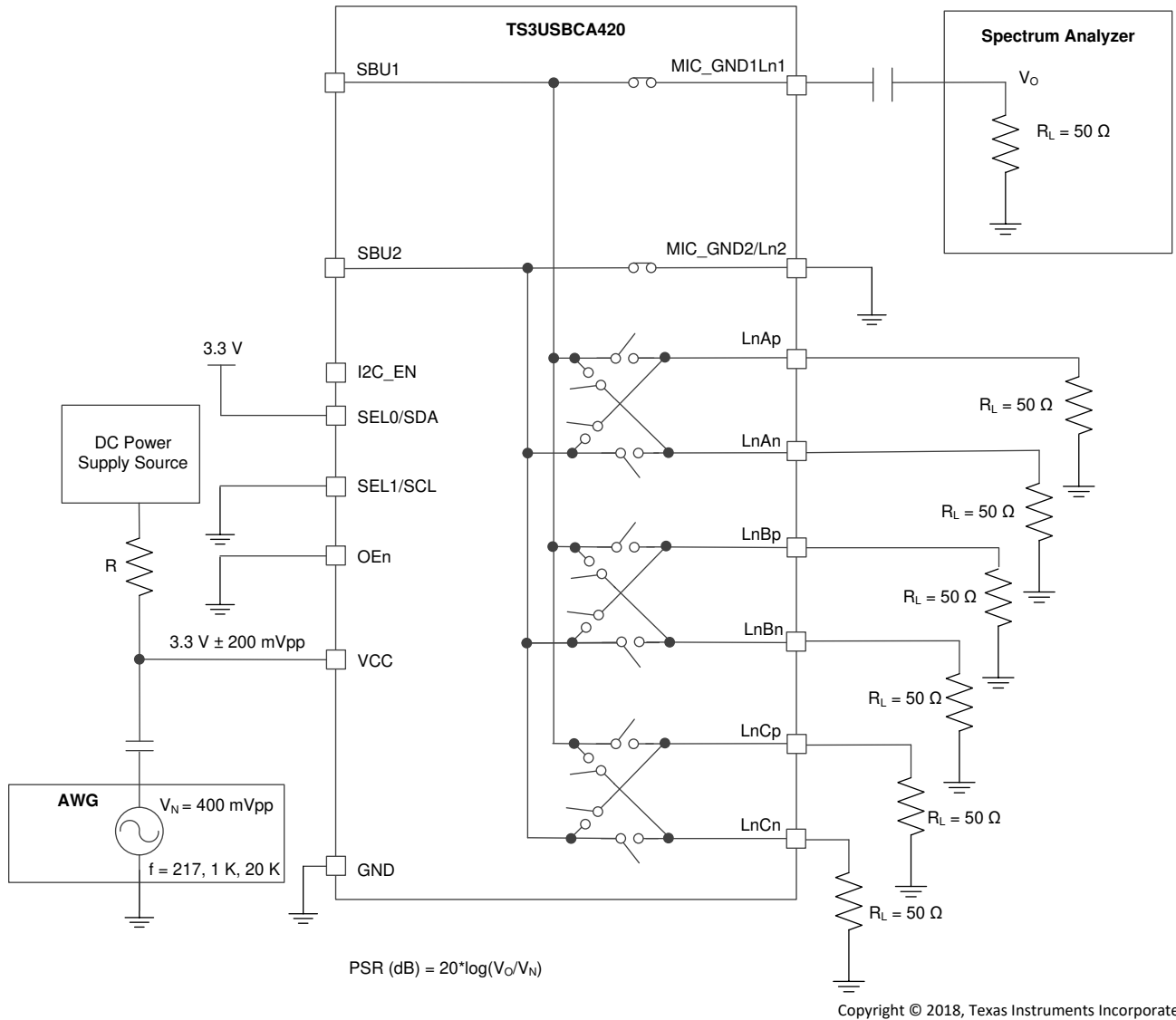
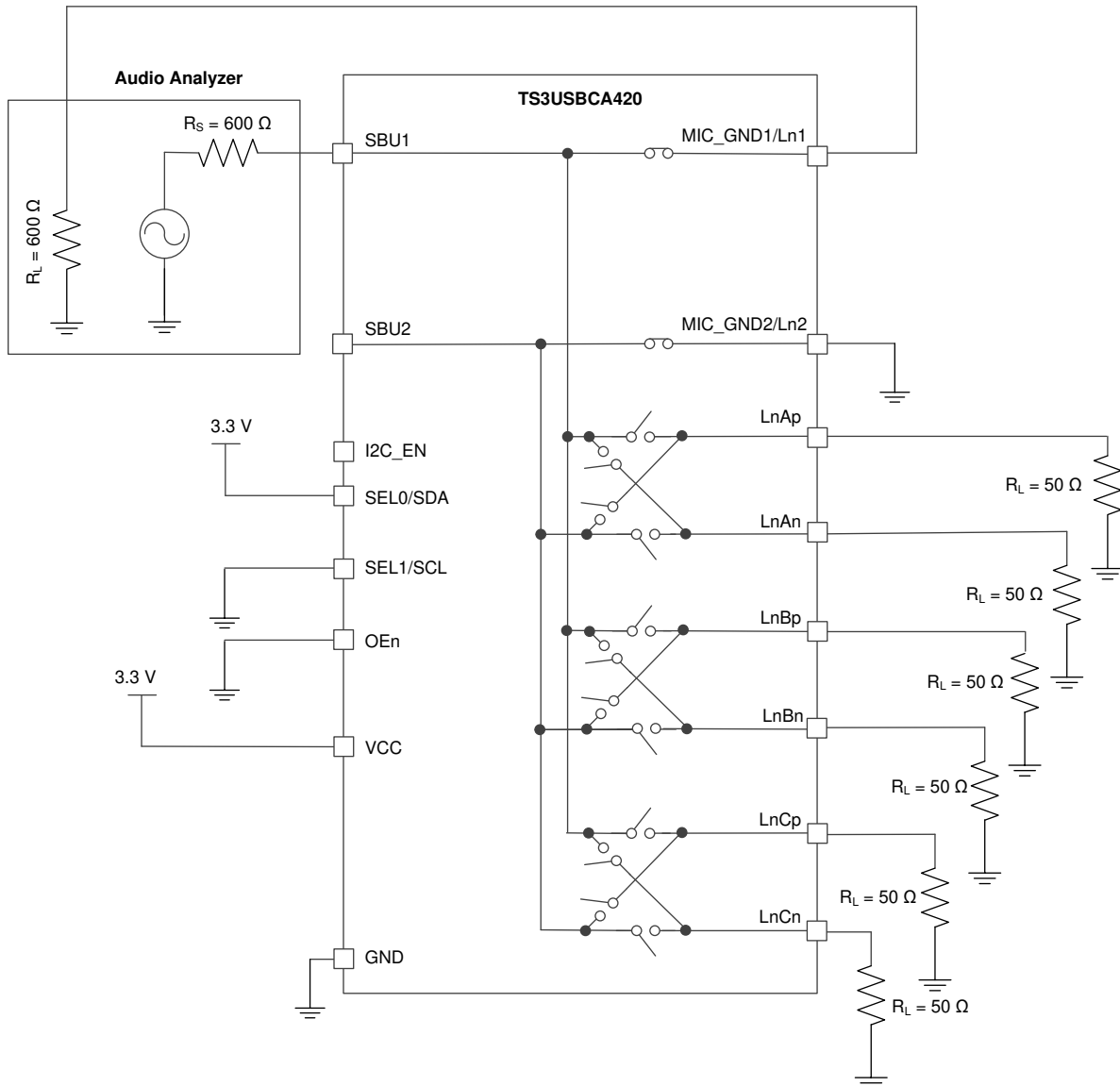

Figure 10. Power Supply Rejection (PSR)

Parameter Measurement Information (continued)



Copyright © 2018, Texas Instruments Incorporated

11. Total Harmonic Distortion (THD)

Parameter Measurement Information (continued)

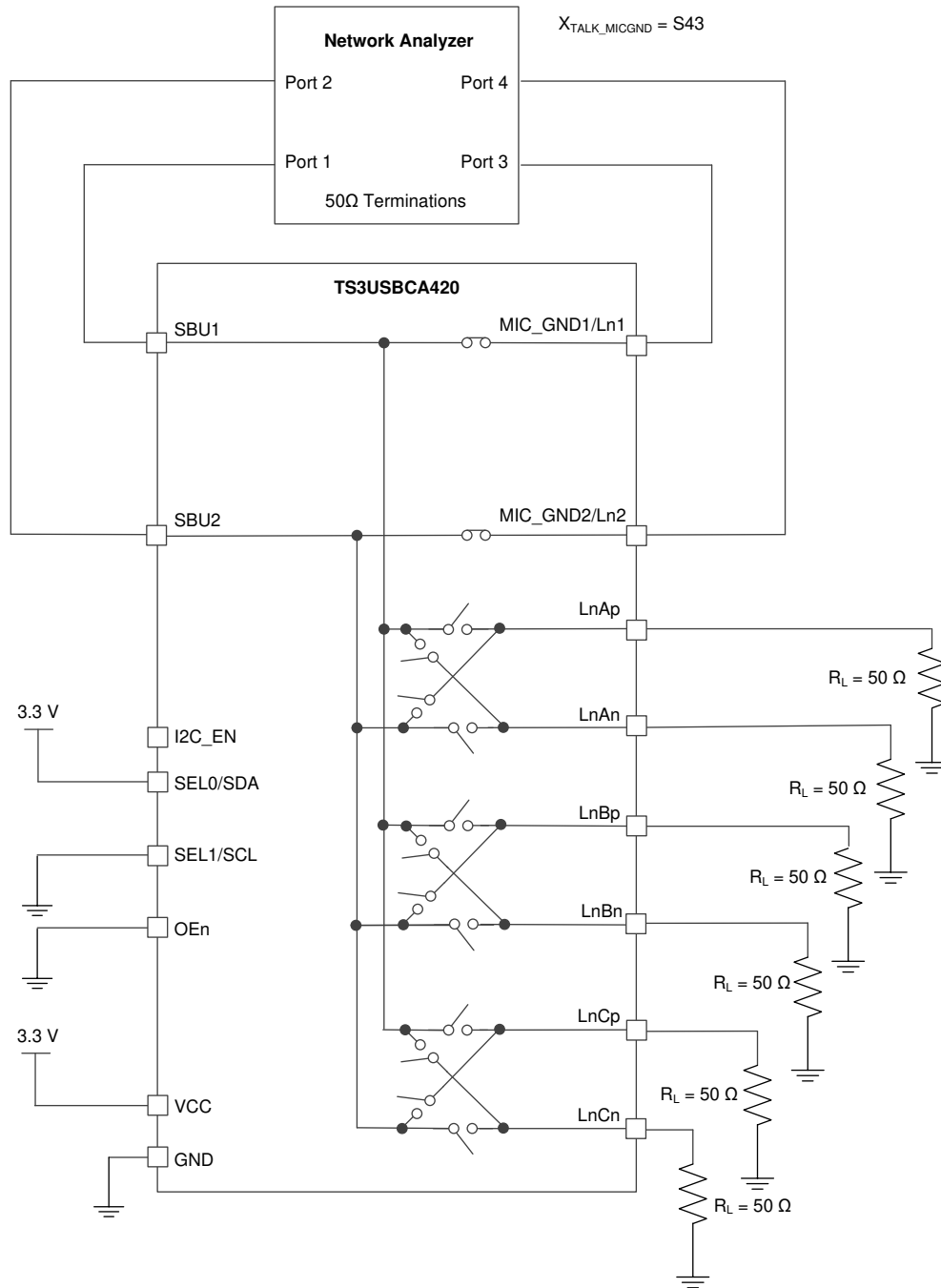

Copyright © 2018, Texas Instruments Incorporated

Figure 12. Crosstalk Between MIC and AGND (XTALK_{MICGND})

Parameter Measurement Information (continued)

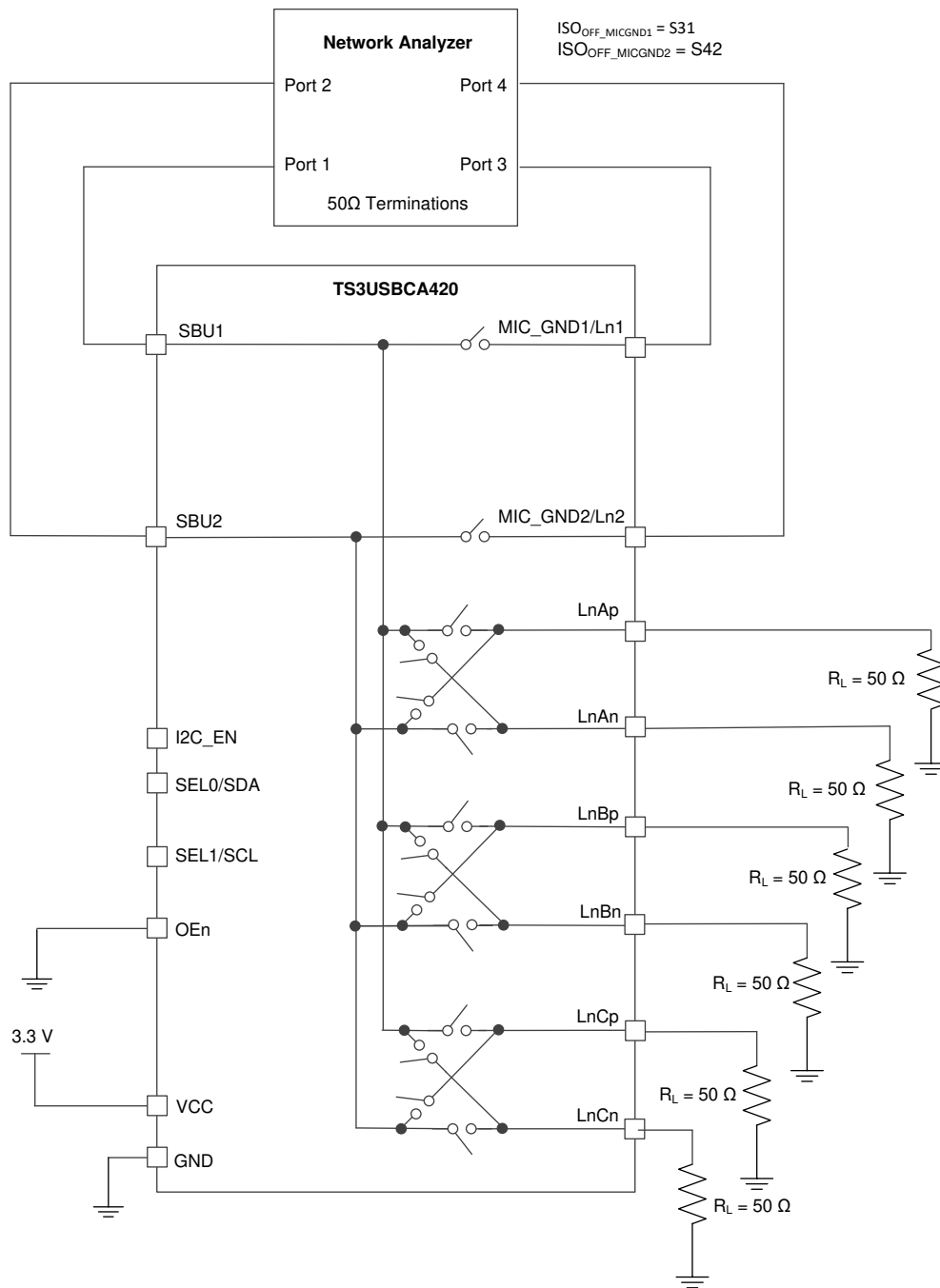

Copyright © 2018, Texas Instruments Incorporated

图 13. OFF Isolation (ISO_{OFF_MICGND})

Parameter Measurement Information (continued)

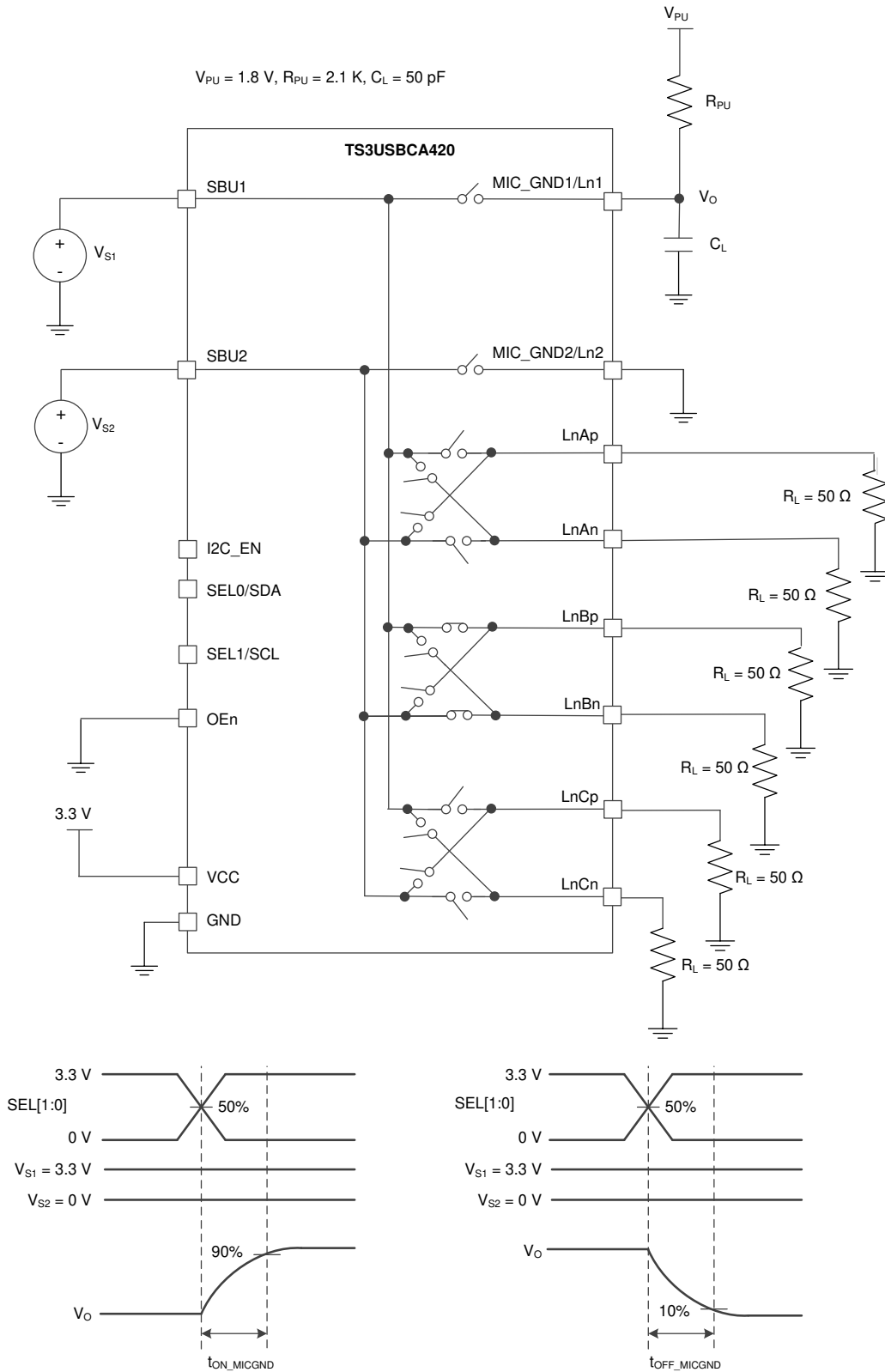

Copyright © 2018, Texas Instruments Incorporated

14. Turn-ON time (t_{ON}) and Turn-OFF time (t_{OFF}) for MIC and AGND

Parameter Measurement Information (continued)

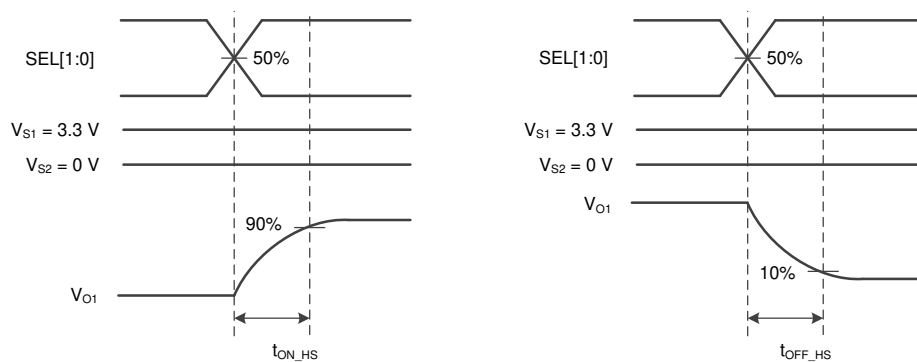
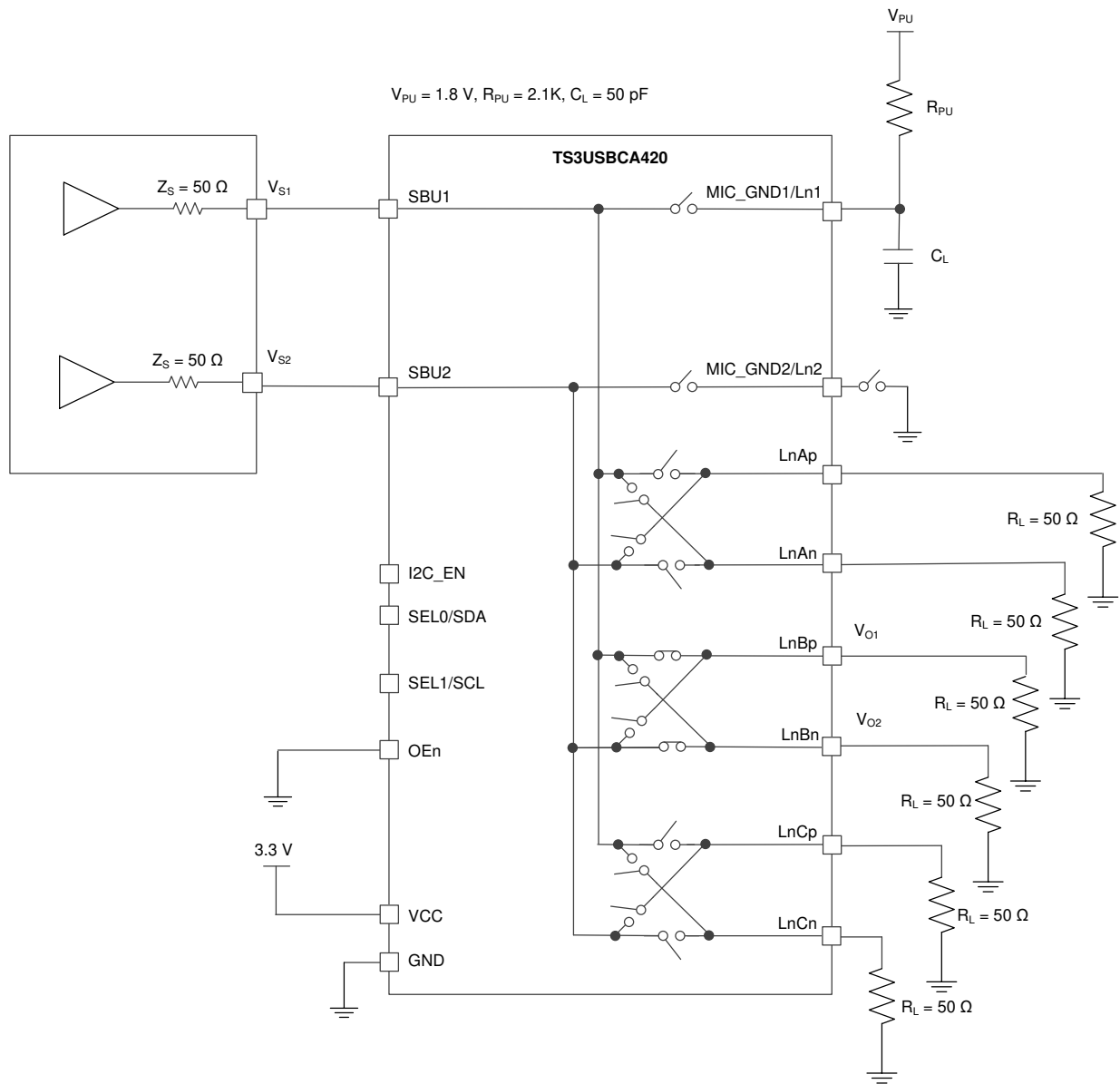

Copyright © 2018, Texas Instruments Incorporated

15. Turn-ON time (t_{ON}) and Turn-OFF time (t_{OFF}) for High-Speed Data Paths

Parameter Measurement Information (continued)

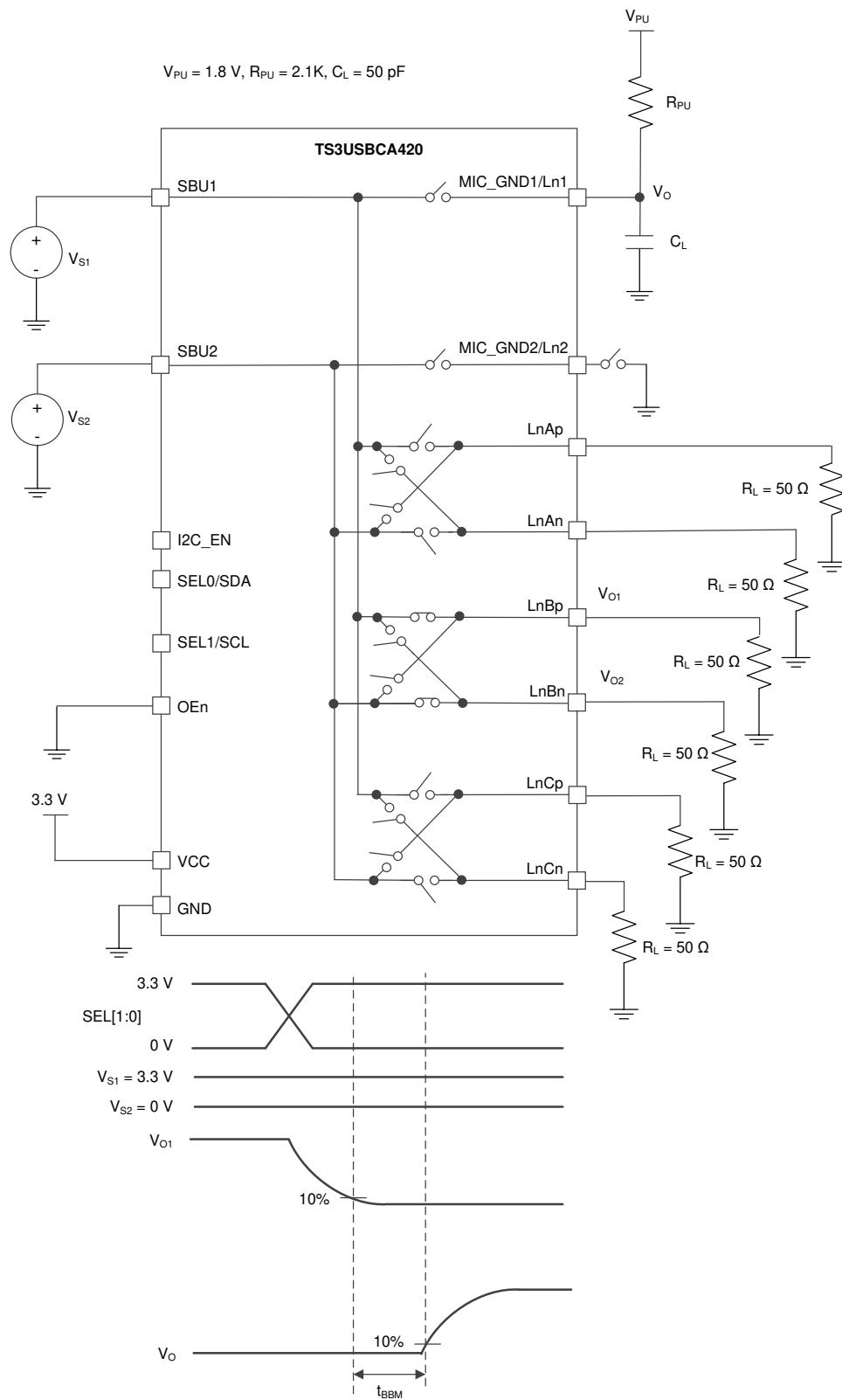

Copyright © 2018, Texas Instruments Incorporated

16. Break-Before-Make Time (t_{BBM})

8 Detailed Description

8.1 Overview

The TS3USBCA4 is a passive 4:1 (TS3USBCA420) and 3:1 (TS3USBCA410) MUX. It supports differential or single-ended signals on the SBU1/SBU2 terminals of a USB Type-C connected to different interfaces. The signals can be DisplayPort auxiliary (AUX), analog audio MIC and AGND, PCIe differential clock, or any other supported generic differential or single-ended signals.

The audio path features ultra-low ON-state resistance (R_{ON}), low crosstalk and excellent total harmonic distortion (THD). The break-before-make feature prevents signal distortion during signal transfer from one channel to another. The high-speed paths support bandwidth as high as 500 MHz to provide adequate support for DisplayPort AUX, PCIe clock, and other similar signals. Together with low power consumption, these features make this device suitable for portable audio applications.

The TS3USBCA4 supports operation from a wide V_{CC} range between 2.4 V and 5.5 V, which gives the system designer the flexibility of powering the device from various sources, such as a regulator, a single-cell battery, or VBUS. The TS3USBCA4 provides options for both commercial and industrial temperature ranges.

8.2 Functional Block Diagram

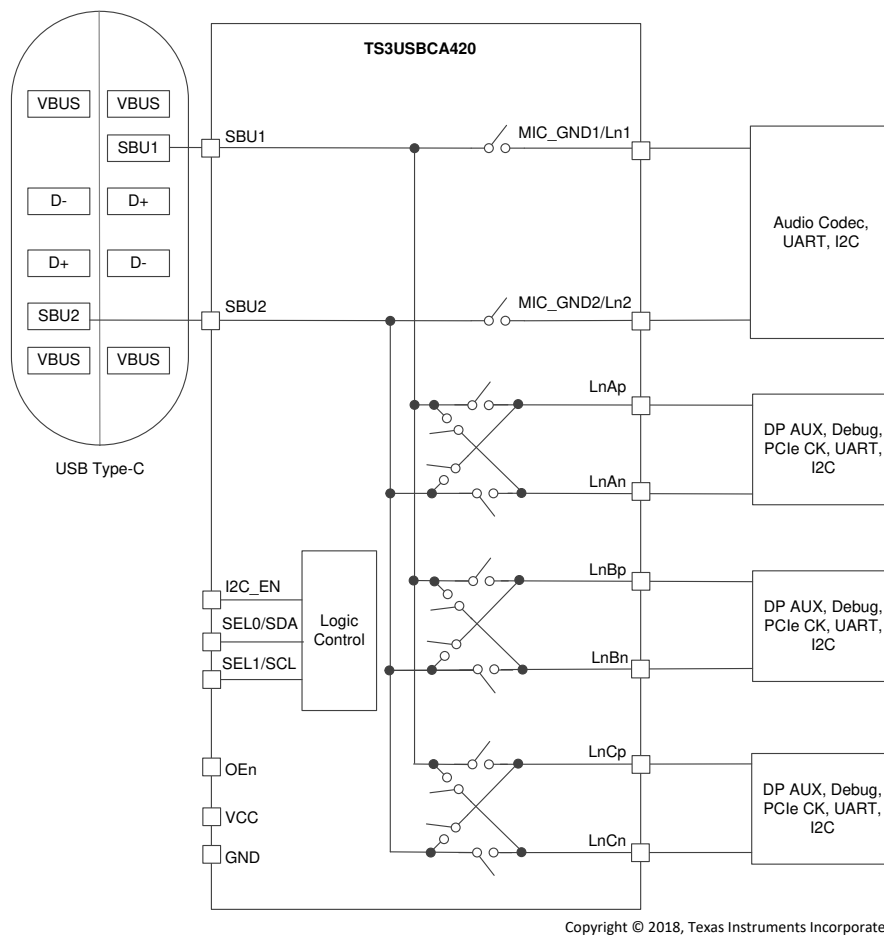

✎ 17. Functional Block Diagram

8.3 Feature Description

8.3.1 Analog Audio Path

The TS3USBCA4 supports analog audio switching between the SBU1 and SBU2 pins on one side of the switch. It supports the MIC_GND1 and MIC_GND2 pins on the other side of the switch. This audio path has an ultra-low ON resistance and low total harmonic distortion for better audio performance.

The MIC and AGND paths are identical by design, with both providing ultra-low R_{ON} . The audio path does not support flipping MIC and AGND. The audio codec should provide this function.

8.3.2 High-Speed Paths

The TS3USBCA4 supports three (TS3USBCA420) or two (TS3USBCA410) high-speed paths between the SBU1 and SBU2 pins on one side of the switch. The LnAp/LnAn, LnBp/LnBn or LnCp/LnCn pins on the other side of the switch. The high-speed paths are identical by design. All high-speed paths have a 500-MHz bandwidth, a low ON-state resistance, and low additive random jitter for signal integrity. For different USB Type-C plug orientations, the polarity of each high-speed lane can be flipped through the I²C interface in TS3USBCA420, or through either the I²C interface or pin control in TS3USBCA410.

8.3.3 3-level Input

The 3-level input pin I2C_EN is used to enable the I²C interface and to choose between two I²C slave addresses to avoid address conflict. The settings for the three levels are shown in [表 1](#).

表 1. 3-Level Control Pin Settings

Level	I2C_EN Pin Settings	Configuration Mode
L	Tied directly to GND or left floating	Pin-configuration mode
M	Tied directly to $V_{CC}/2$	I ² C-configuration mode with ADDR0
H	Tied directly to V_{CC}	I ² C-configuration mode with ADDR1

8.4 Device Functional Modes

Switch selection and flipping can be controlled either through the I²C interface in I²C-configuration mode or through the control pins (SEL0, SEL1, and FLIP when applicable) in pin-configuration mode, according to 表 1. 表 2 and 表 3 show the configuration truth table for TS3USBCA420 and TS3USBCA410, respectively. Note in TS3USBCA420 the flipping capability is available only in I²C-configuration mode.

表 2. TS3USBCA420 Switch Configuration Truth Table⁽¹⁾

{SWSEL[1:0], FLIPSEL} (I ² C-Configuration Mode)	{SEL1, SEL0} (Pin-Configuration Mode)	Input Pin	Output Pin
000	LL	SBU1	LnBp
		SBU2	LnBn
001		SBU1	LnBn
		SBU2	LnBp
010	LH	SBU1	MIC_GND1/Ln1
		SBU2	MIC_GND2/Ln2
011		SBU1	MIC_GND1/Ln1
		SBU2	MIC_GND2/Ln2
100	HL	SBU1	LnCp
		SBU2	LnCn
101		SBU1	LnCp
		SBU2	LnCn
110	HH	SBU1	LnAp
		SBU2	LnAn
111		SBU1	LnAn
		SBU2	LnAp

(1) For normal operation, drive OEn low (and in I²C mode set DEVICE_ENABLE = 1'b1). Driving the OEn pin high (or in I²C mode setting DEVICE_ENABLE = 1'b0) disables the switch. Note: The ports which are not selected by the control lines are in high impedance state

表 3. TS3USBCA410 Switch Configuration Truth Table⁽¹⁾

{SWSEL[1:0], FLIPSEL} (I ² C-Configuration Mode)	{SEL1, SEL0, FLIP} (Pin-Configuration Mode)	Input Pin	Output Pin
000	LLL	SBU1	LnBp
		SBU2	LnBn
001	LLH	SBU1	LnBn
		SBU2	LnBp
010	LHL	SBU1	MIC_GND1/Ln1
		SBU2	MIC_GND2/Ln2
011	LHH	SBU1	MIC_GND1/Ln1
		SBU2	MIC_GND2/Ln2
100	HLL	SBU1	
		SBU2	
101	HLH	SBU1	
		SBU2	
110	HHL	SBU1	LnAp
		SBU2	LnAn
111	HHH	SBU1	LnAn
		SBU2	LnAp

(1) For normal operation, drive OEn low (and in I²C mode set DEVICE_ENABLE = 1'b1). Driving the OEn pin high (or in I²C mode setting DEVICE_ENABLE = 1'b0) disables the switch. Note: The ports which are not selected by the control lines are in high impedance state

In addition to switch control, the I²C-configuration mode also allows enabling and disabling the device through the *DEVICE_ENABLE* register. 表 4 shows the details.

表 4. TS3USBCA4 Enable/Disable Truth Table

OEn	DEVICE_ENABLE	Device Behavior
L	0	Device is shut down with I _{OFF_I2C} . On-chip bandgap and IO buffers are still on. I ² C is functional.
L	1	Normal operation.
H	X	Device is under reset with I _{OFF_OEN} . On-chip bandgap and IO buffers are off. I ² C is not functional.

8.5 Programming

The TS3USBCA4 can be controlled using I²C. The SCL and SDA terminals are used for I²C clock and I²C data respectively.

表 5. TS3USBCA4 I²C Slave Address

ADDR	Bit 7 (MSB)	Bit 6	Bit 5	Bit 4	Bit 3	Bit 2	Bit 1	Bit 0 (W/R)
ADDR0	1	0	1	1	1	0	0	0/1
ADDR1	1	0	1	1	1	0	1	0/1

The following procedure should be followed to write to TS3USBCA4 I²C registers:

1. The master initiates a write operation by generating a start condition (S), followed by the TS3USBCA4 7-bit address and a zero-value “W/R” bit to indicate a write cycle
2. The TS3USBCA4 acknowledges the address cycle.
3. The master presents the sub-address (I²C register within TS3USBCA4) to be written, consisting of one byte of data, MSB-first.
4. The TS3USBCA4 acknowledges the sub-address cycle.
5. The master presents the first byte of data to be written to the I²C register.
6. The TS3USBCA4 acknowledges the byte transfer.
7. The master may continue presenting additional bytes of data to be written, with each byte transfer completing with an acknowledge from the TS3USBCA4.
8. The master terminates the write operation by generating a stop condition (P).

The following procedure should be followed to read the TS3USBCA4 I²C registers:

1. The master initiates a read operation by generating a start condition (S), followed by the TS3USBCA4 7-bit address and a one-value “W/R” bit to indicate a read cycle
2. The TS3USBCA4 acknowledges the address cycle.
3. The TS3USBCA4 transmit the contents of the memory registers MSB-first starting at register 00h or last read sub-address+1. If a write to the I²C register occurred prior to the read, then the TS3USBCA4 shall start at the sub-address specified in the write.
4. The TS3USBCA4 shall wait for either an acknowledge (ACK) or a not-acknowledge (NACK) from the master after each byte transfer; the I²C master acknowledges reception of each data byte transfer.
5. If an ACK is received, the TS3USBCA4 transmits the next byte of data.
6. The master terminates the read operation by generating a stop condition (P).

The following procedure should be followed for setting a starting sub-address for I²C reads:

1. The master initiates a write operation by generating a start condition (S), followed by the TS3USBCA4 7-bit address and a zero-value “W/R” bit to indicate a write cycle.
2. The TS3USBCA4 acknowledges the address cycle.
3. The master presents the sub-address (I²C register within TS3USBCA4) to be written, consisting of one byte of data, MSB-first.
4. The TS3USBCA4 acknowledges the sub-address cycle.
5. The master terminates the write operation by generating a stop condition (P).

注

Upon reset, the TS3USBCA4 sub-address is always set to 0x00. The TS3USBCA4 increments the sub-address by one after each successful read or write transaction, so that the next read transaction that does not explicitly specify the sub-address will start from the next register.

8.6 Register Maps

8.6.1 TS3USBCA4 Registers

Table 6 lists the memory-mapped registers for the TS3USBCA4 registers. All register offset addresses not listed in Table 6 should be considered as reserved locations and the register contents should not be modified.

Table 6. TS3USBCA4 Registers

Offset	Acronym	Register Name	Section
9h	Revision_ID	Revision ID	Go
Ah	General_1	Enable and FLIPSEL control	Go
Bh	General_2	SWSEL control	Go

Complex bit access types are encoded to fit into small table cells. Table 7 shows the codes that are used for access types in this section.

Table 7. TS3USBCA4 Access Type Codes

Access Type	Code	Description
Read Type		
R	R	Read
Write Type		
W	W	Write
Reset or Default Value		
-n		Value after reset or the default value

8.6.1.1 Revision_ID Register (Offset = 9h) [reset = 0h]

Revision_ID is shown in Figure 18 and described in Table 8.

Return to [Summary Table](#).

Figure 18. Revision_ID Register

7	6	5	4	3	2	1	0
RESERVED				REVISION_ID			
R-0h				R-0h			

Table 8. Revision_ID Register Field Descriptions

Bit	Field	Type	Reset	Description
7-4	RESERVED	R	0h	Reserved
3-0	REVISION_ID	R	0h	Silicon revision.

8.6.1.2 General_1 Register (Offset = Ah) [reset = 0h]

General_1 is shown in Figure 19 and described in Table 9.

Return to [Summary Table](#).

Figure 19. General_1 Register

7	6	5	4	3	2	1	0
RESERVED						DEVICE_ENAB LE	FLIPSEL
R-0h						R/W-0h	R/W-0h

Table 9. General_1 Register Field Descriptions

Bit	Field	Type	Reset	Description
7-2	RESERVED	R	0h	Reserved
1	DEVICE_ENABLE	R/W	0h	Controls the switch enable. 0h = Disabled 1h = Enabled
0	FLIPSEL	R/W	0h	Controls the USB-C orientation. 0h = Normal Orientation 1h = Flip orientation.

8.6.1.3 General_2 Register (Offset = Bh) [reset = 0h]

 General_2 is shown in [Figure 20](#) and described in [Table 10](#).

 Return to [Summary Table](#).

Figure 20. General_2 Register

7	6	5	4	3	2	1	0
RESERVED						SWSEL	
R-0h						R/W-0h	

Table 10. General_2 Register Field Descriptions

Bit	Field	Type	Reset	Description
7-2	RESERVED	R	0h	Reserved
1-0	SWSEL	R/W	0h	This field along with FLIPSEL controls the SBU switch connections. 0h = SBU to LnB 1h = SBU to MICGND 2h = SBU to LnC 3h = SBU to LnA

9 Application and Implementation

注

Information in the following applications sections is not part of the TI component specification, and TI does not warrant its accuracy or completeness. TI's customers are responsible for determining suitability of components for their purposes. Customers should validate and test their design implementation to confirm system functionality.

9.1 Application Information

The SBU1 and SBU2 pins of a USB type-C connector can be re-purposed in different applications. Examples include DisplayPort AUX, analog audio MIC and AGND, and debug signals. The TS3USBCA4 is controlled by a micro-processor (that is, an application processor in a smartphone) that routes SBU1 and SBU2 to the desired destination, such as a DisplayPort source or sink, an audio codec, or a processor. The TS3USBCA4 provides cross-switch capability for different USB type-C plug orientations.

9.2 Typical Application

Figure 21 shows the typical application of TS3USBCA420 in I²C-configuration mode from a 3.3-V supply. The I²C slave address is set to ADDR1. V_{IO_UP} is the supply for the micro-processor IOs.

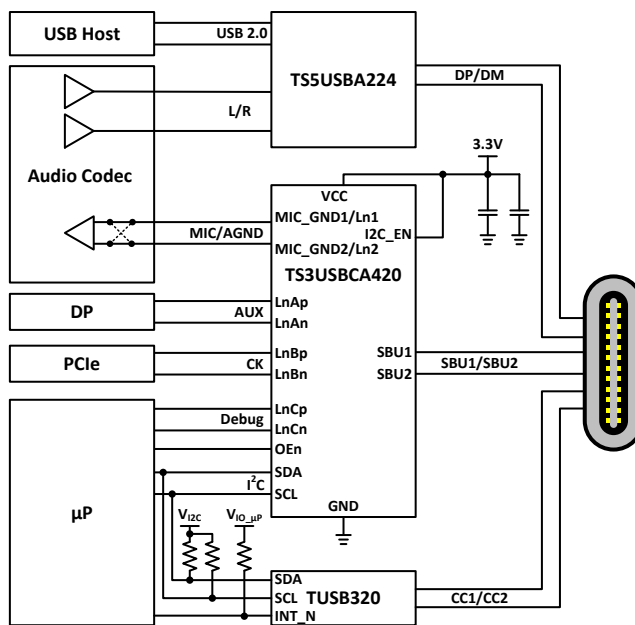

Copyright © 2018, Texas Instruments Incorporated

Figure 21. Application of TS3USBCA420 in I²C-Configuration Mode

Figure 22 shows the typical application of TS3USBCA420 in pin-configuration mode from VBUS. V_{IO_UP} is the supply for the micro-processor IOs.

Typical Application (continued)

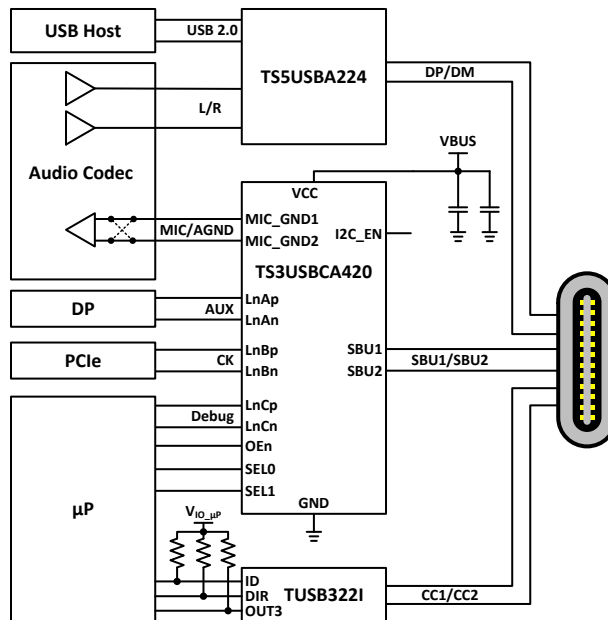
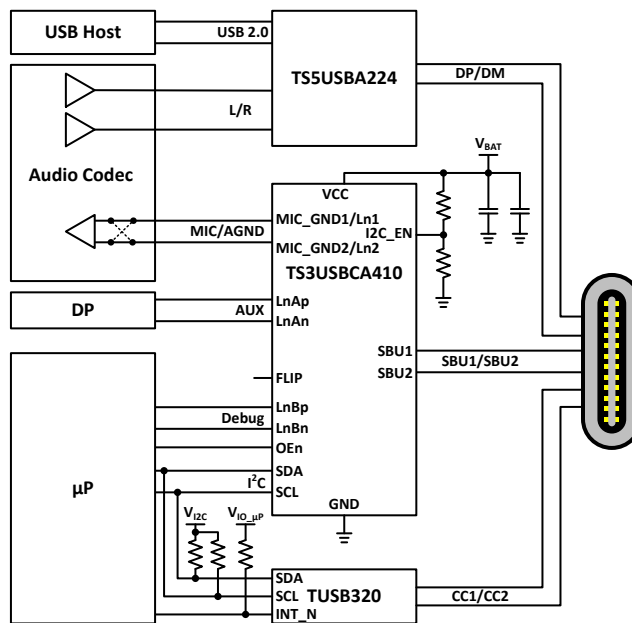

Figure 22. Application of TS3USBCA420 in Pin-Configuration Mode

Figure 21 shows the typical application of TS3USBCA410 in I²C-configuration mode from V_{BAT}. The I²C slave address is set to ADDR0. V_{IO_UP} is the supply for the micro-processor IOs.



Copyright © 2018, Texas Instruments Incorporated

Figure 23. Application of TS3USBCA410 in I²C-Configuration Mode

Figure 22 shows the typical application of TS3USBCA410 in pin-configuration mode from VBUS. V_{IO_UP} is the supply for the micro-processor IOs.

Typical Application (continued)

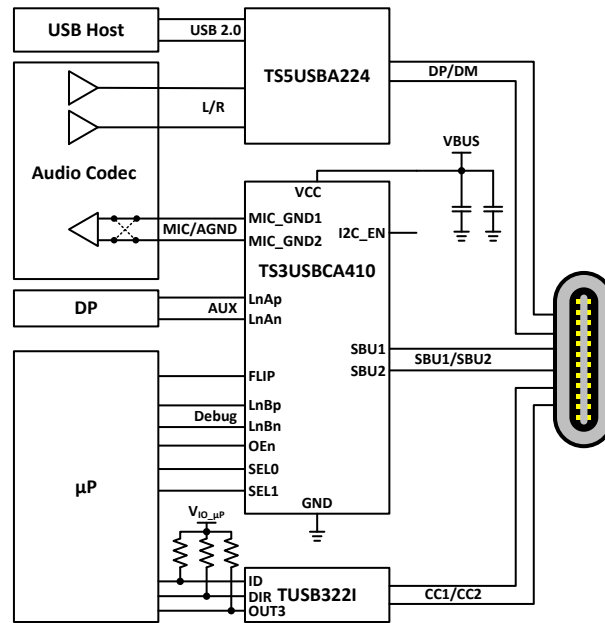

Figure 24. Application of TS3USBCA410 in Pin-Configuration Mode

9.2.1 Design Requirements

Design requirements of USB type-C and other relevant standards (DisplayPort, analog audio, etc.) must be followed.

9.2.2 Detailed Design Procedure

The design procedure starts with the choice of supply. TS3USBCA4 wide supply range from 2.4 V to 5.5 V gives the designer flexibility when selecting a supply. Examples include, but are not limited to, a single-cell battery, a 3.3-V regulator, or VBUS. The designer must account for the parametric variation of TS3USBCA4 with supply range, the supply range of other components in the system, the IO voltage levels of companion devices, and cost. For example, a regulated 3.3-V V_{CC} has the advantage of smaller variation of TS3USBCA4 performance compared to a single-cell battery between 2.7 V and 4.3 V. This regulator may add to the system cost and board area.

The next step in the design procedure is to choose between I²C- and pin-configuration mode. The I²C-configuration mode is preferred because it reduces the number of IOs needed from the micro-processor. Note that in TS3USBCA420 the flip functionality is only available in the I²C-configuration mode. The designer can choose from two I²C slave addresses through pin-strapping of I2C_EN to avoid address conflict. The IOs of TS3USBCA4 have well-controlled V_{IH} and V_{IL} and are supposed to work with a wide range of IO voltage levels of the micro-processor. However, the designer needs to check the compatibility of the IOs between the micro-processor and TS3USBCA4, and insert level translators when necessary.

In I²C-configuration mode, when it is necessary to set I2C_EN to the middle level to avoid slave address conflict, it is desirable to use as high a resistor value as possible for the resistor divider to minimize the static current through the resistor divider. However, the designer needs to take into account the resistor tolerance and the effect of the on-chip pull-down resistor to ensure a satisfactory voltage margin for V_{IM} of the I2C_EN pin.

It should be noted that the bandwidth of the high-speed lanes is defined with the audio channel open. Due to the low R_{ON} of the audio channel, big parasitic capacitance exists between the audio output port and the SBU port. The load (capacitive and/or resistive) at the audio output port may significantly impact the bandwidth of the high-speed lanes. If bandwidth is importance, the audio channel is preferred. If certain high-speed signals have to go through the high-speed lanes, care should be taken to minimize the load at the audio output port, including the traces.

Typical Application (continued)

9.2.3 Application Curves

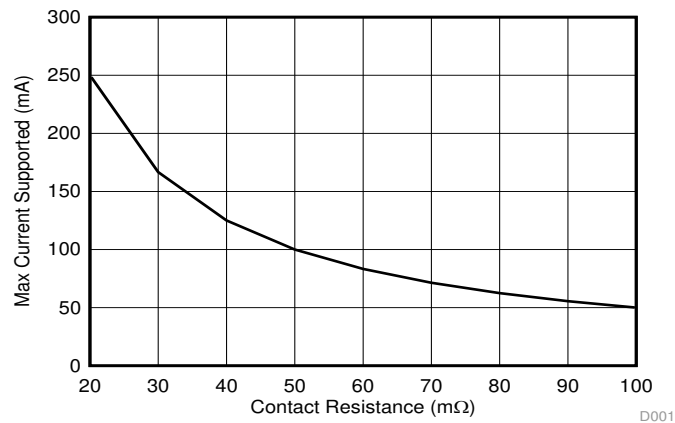

Figure 25. Max Current vs Contact Resistance

10 Power Supply Recommendations

The TS3USBCA4 is designed to operate from a V_{CC} range between 2.4 V and 5.5 V. The supply is recommended to be decoupled to ground via two de-coupling capacitors of 0.1 μF and 1 μF placed as close as possible to the TS3USBCA4. To ensure a POR trip during a power-down and power-on event the power supply should follow the minimum and maximum V_{CC} rise and fall times specified in the electrical specifications section.

11 Layout

11.1 Layout Guidelines

- The V_{CC} pin must have de-coupling capacitors placed as closely to the device as possible. Typically recommended capacitors are a 0.1- μF and a 1- μF capacitor.
- The total resistance from SBU1 and SBU2 pins of the type-C connector to the MIC_GND1 and MIC_GND2 pins of the audio codec should be kept low to avoid degrading the crosstalk performance.
- Route the I²C and digital signals away from the audio signals to prevent coupling onto the audio lines.

11.2 Layout Example

Figure 26 shows a layout example of TS3USBCA420.

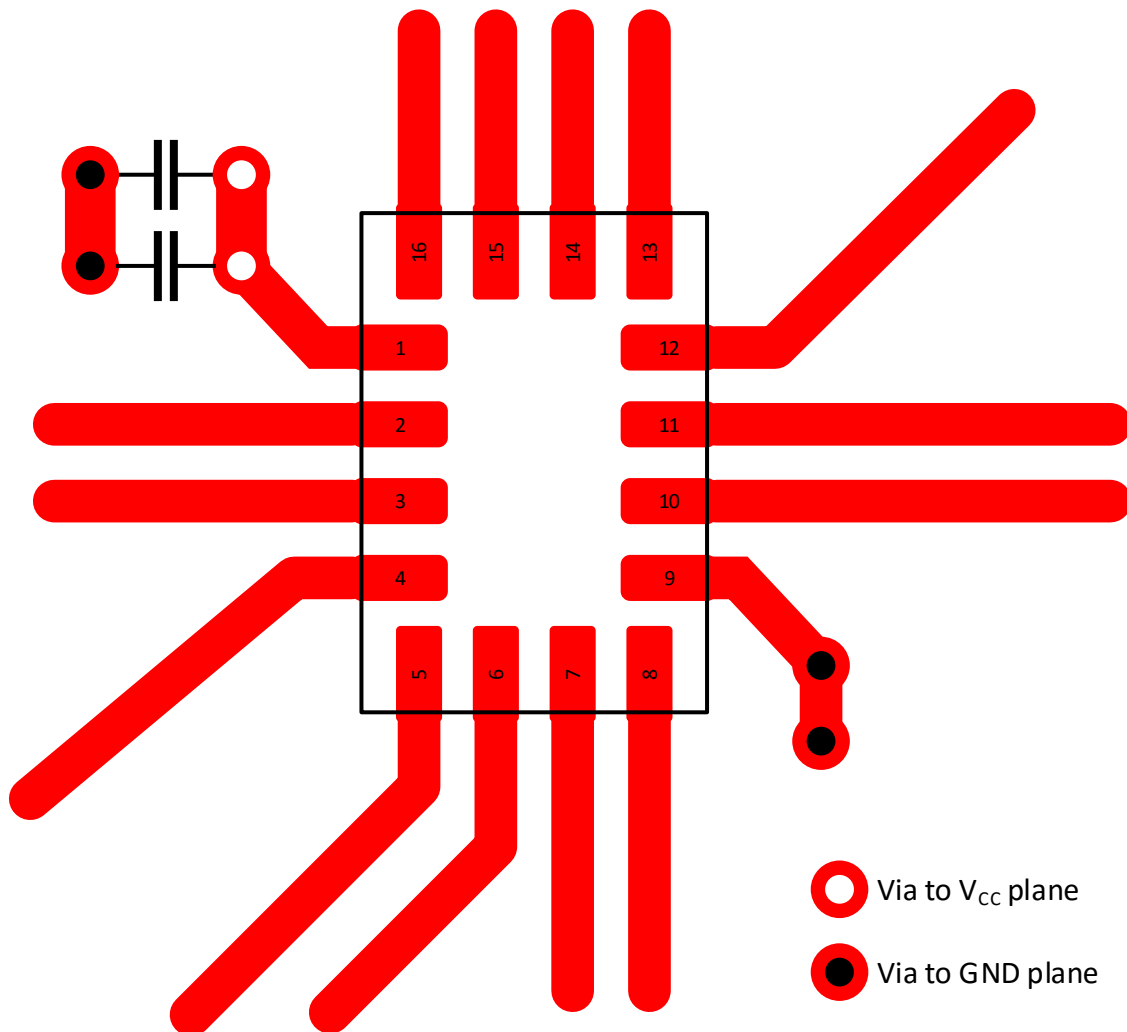

Figure 26. Layout Example

12 デバイスおよびドキュメントのサポート

12.1 ドキュメントの更新通知を受け取る方法

ドキュメントの更新についての通知を受け取るには、ti.comのデバイス製品フォルダを開いてください。右上の「アラートを受け取る」をクリックして登録すると、変更されたすべての製品情報に関するダイジェストを毎週受け取れます。変更の詳細については、修正されたドキュメントに含まれている改訂履歴をご覧ください。

12.2 サポート・リソース

[TI E2E™ support forums](#) are an engineer's go-to source for fast, verified answers and design help — straight from the experts. Search existing answers or ask your own question to get the quick design help you need.

Linked content is provided "AS IS" by the respective contributors. They do not constitute TI specifications and do not necessarily reflect TI's views; see TI's [Terms of Use](#).

12.3 商標

E2E is a trademark of Texas Instruments.

USB Type-C is a trademark of USB Implementers Forum.

12.4 静電気放電に関する注意事項



すべての集積回路は、適切なESD保護方法を用いて、取扱いと保存を行うようにして下さい。

静電気放電はわずかな性能の低下から完全なデバイスの故障に至るまで、様々な損傷を与えます。高精度の集積回路は、損傷に対して敏感であり、極めてわずかなパラメータの変化により、デバイスに規定された仕様に適合しなくなる場合があります。

12.5 Glossary

[SLYZ022](#) — *TI Glossary*.

This glossary lists and explains terms, acronyms, and definitions.

13 メカニカル、パッケージ、および注文情報

以降のページには、メカニカル、パッケージ、および注文に関する情報が記載されています。この情報は、そのデバイスについて利用可能な最新のデータです。このデータは予告なく変更されることがあり、ドキュメントが改訂される場合もあります。本データシートのブラウザ版を使用されている場合は、画面左側の説明をご覧ください。

PACKAGING INFORMATION

Orderable Device	Status (1)	Package Type	Package Drawing	Pins	Package Qty	Eco Plan (2)	Lead finish/ Ball material (6)	MSL Peak Temp (3)	Op Temp (°C)	Device Marking (4/5)	Samples
TS3USBCA410IRSVR	ACTIVE	UQFN	RSV	16	3000	RoHS & Green	NIPDAU	Level-1-260C-UNLIM	-40 to 85	410	Samples
TS3USBCA410IRSVT	ACTIVE	UQFN	RSV	16	250	RoHS & Green	NIPDAU	Level-1-260C-UNLIM	-40 to 85	410	Samples
TS3USBCA410RSVR	ACTIVE	UQFN	RSV	16	3000	RoHS & Green	NIPDAU	Level-1-260C-UNLIM	0 to 70	410	Samples
TS3USBCA410RSVT	ACTIVE	UQFN	RSV	16	250	RoHS & Green	NIPDAU	Level-1-260C-UNLIM	0 to 70	410	Samples
TS3USBCA420IRSVR	ACTIVE	UQFN	RSV	16	3000	RoHS & Green	NIPDAU	Level-1-260C-UNLIM	-40 to 85	420	Samples
TS3USBCA420IRSVT	ACTIVE	UQFN	RSV	16	250	RoHS & Green	NIPDAU	Level-1-260C-UNLIM	-40 to 85	420	Samples
TS3USBCA420RSVR	ACTIVE	UQFN	RSV	16	3000	RoHS & Green	NIPDAU	Level-1-260C-UNLIM	0 to 70	420	Samples
TS3USBCA420RSVT	ACTIVE	UQFN	RSV	16	250	RoHS & Green	NIPDAU	Level-1-260C-UNLIM	0 to 70	420	Samples

(1) The marketing status values are defined as follows:

ACTIVE: Product device recommended for new designs.

LIFEBUY: TI has announced that the device will be discontinued, and a lifetime-buy period is in effect.

NRND: Not recommended for new designs. Device is in production to support existing customers, but TI does not recommend using this part in a new design.

PREVIEW: Device has been announced but is not in production. Samples may or may not be available.

OBSELETE: TI has discontinued the production of the device.

(2) **RoHS:** TI defines "RoHS" to mean semiconductor products that are compliant with the current EU RoHS requirements for all 10 RoHS substances, including the requirement that RoHS substance do not exceed 0.1% by weight in homogeneous materials. Where designed to be soldered at high temperatures, "RoHS" products are suitable for use in specified lead-free processes. TI may reference these types of products as "Pb-Free".

RoHS Exempt: TI defines "RoHS Exempt" to mean products that contain lead but are compliant with EU RoHS pursuant to a specific EU RoHS exemption.

Green: TI defines "Green" to mean the content of Chlorine (Cl) and Bromine (Br) based flame retardants meet JS709B low halogen requirements of <=1000ppm threshold. Antimony trioxide based flame retardants must also meet the <=1000ppm threshold requirement.

(3) MSL, Peak Temp. - The Moisture Sensitivity Level rating according to the JEDEC industry standard classifications, and peak solder temperature.

(4) There may be additional marking, which relates to the logo, the lot trace code information, or the environmental category on the device.

(5) Multiple Device Markings will be inside parentheses. Only one Device Marking contained in parentheses and separated by a "~" will appear on a device. If a line is indented then it is a continuation of the previous line and the two combined represent the entire Device Marking for that device.

⁽⁶⁾ Lead finish/Ball material - Orderable Devices may have multiple material finish options. Finish options are separated by a vertical ruled line. Lead finish/Ball material values may wrap to two lines if the finish value exceeds the maximum column width.

Important Information and Disclaimer:The information provided on this page represents TI's knowledge and belief as of the date that it is provided. TI bases its knowledge and belief on information provided by third parties, and makes no representation or warranty as to the accuracy of such information. Efforts are underway to better integrate information from third parties. TI has taken and continues to take reasonable steps to provide representative and accurate information but may not have conducted destructive testing or chemical analysis on incoming materials and chemicals. TI and TI suppliers consider certain information to be proprietary, and thus CAS numbers and other limited information may not be available for release.

In no event shall TI's liability arising out of such information exceed the total purchase price of the TI part(s) at issue in this document sold by TI to Customer on an annual basis.

TAPE AND REEL INFORMATION

QUADRANT ASSIGNMENTS FOR PIN 1 ORIENTATION IN TAPE

*All dimensions are nominal

Device	Package Type	Package Drawing	Pins	SPQ	Reel Diameter (mm)	Reel Width W1 (mm)	A0 (mm)	B0 (mm)	K0 (mm)	P1 (mm)	W (mm)	Pin1 Quadrant
TS3USBCA410IRSVR	UQFN	RSV	16	3000	178.0	13.5	2.1	2.9	0.75	4.0	12.0	Q1
TS3USBCA410IRSVT	UQFN	RSV	16	250	178.0	13.5	2.1	2.9	0.75	4.0	12.0	Q1
TS3USBCA410RSVR	UQFN	RSV	16	3000	178.0	13.5	2.1	2.9	0.75	4.0	12.0	Q1
TS3USBCA410RSVT	UQFN	RSV	16	250	178.0	13.5	2.1	2.9	0.75	4.0	12.0	Q1
TS3USBCA420IRSVR	UQFN	RSV	16	3000	178.0	13.5	2.1	2.9	0.75	4.0	12.0	Q1
TS3USBCA420IRSVT	UQFN	RSV	16	250	178.0	13.5	2.1	2.9	0.75	4.0	12.0	Q1
TS3USBCA420RSVR	UQFN	RSV	16	3000	178.0	13.5	2.1	2.9	0.75	4.0	12.0	Q1
TS3USBCA420RSVT	UQFN	RSV	16	250	178.0	13.5	2.1	2.9	0.75	4.0	12.0	Q1

TAPE AND REEL BOX DIMENSIONS



*All dimensions are nominal

Device	Package Type	Package Drawing	Pins	SPQ	Length (mm)	Width (mm)	Height (mm)
TS3USBCA410IRSVR	UQFN	RSV	16	3000	189.0	185.0	36.0
TS3USBCA410IRSVT	UQFN	RSV	16	250	189.0	185.0	36.0
TS3USBCA410RSVR	UQFN	RSV	16	3000	189.0	185.0	36.0
TS3USBCA410RSVT	UQFN	RSV	16	250	189.0	185.0	36.0
TS3USBCA420IRSVR	UQFN	RSV	16	3000	189.0	185.0	36.0
TS3USBCA420IRSVT	UQFN	RSV	16	250	189.0	185.0	36.0
TS3USBCA420RSVR	UQFN	RSV	16	3000	189.0	185.0	36.0
TS3USBCA420RSVT	UQFN	RSV	16	250	189.0	185.0	36.0

GENERIC PACKAGE VIEW

RSV 16

UQFN - 0.55 mm max height

1.8 x 2.6, 0.4 mm pitch

ULTRA THIN QUAD FLATPACK - NO LEAD

This image is a representation of the package family, actual package may vary.
Refer to the product data sheet for package details.

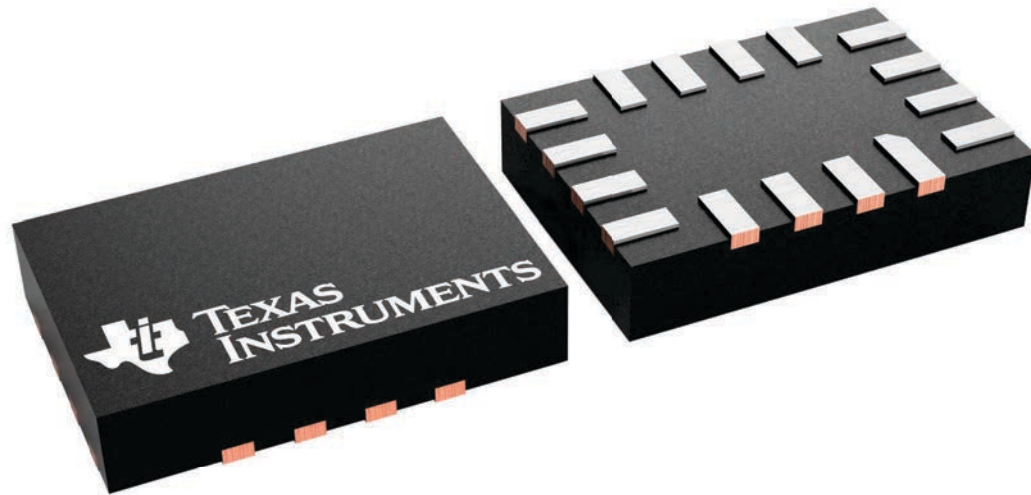

4231225/A

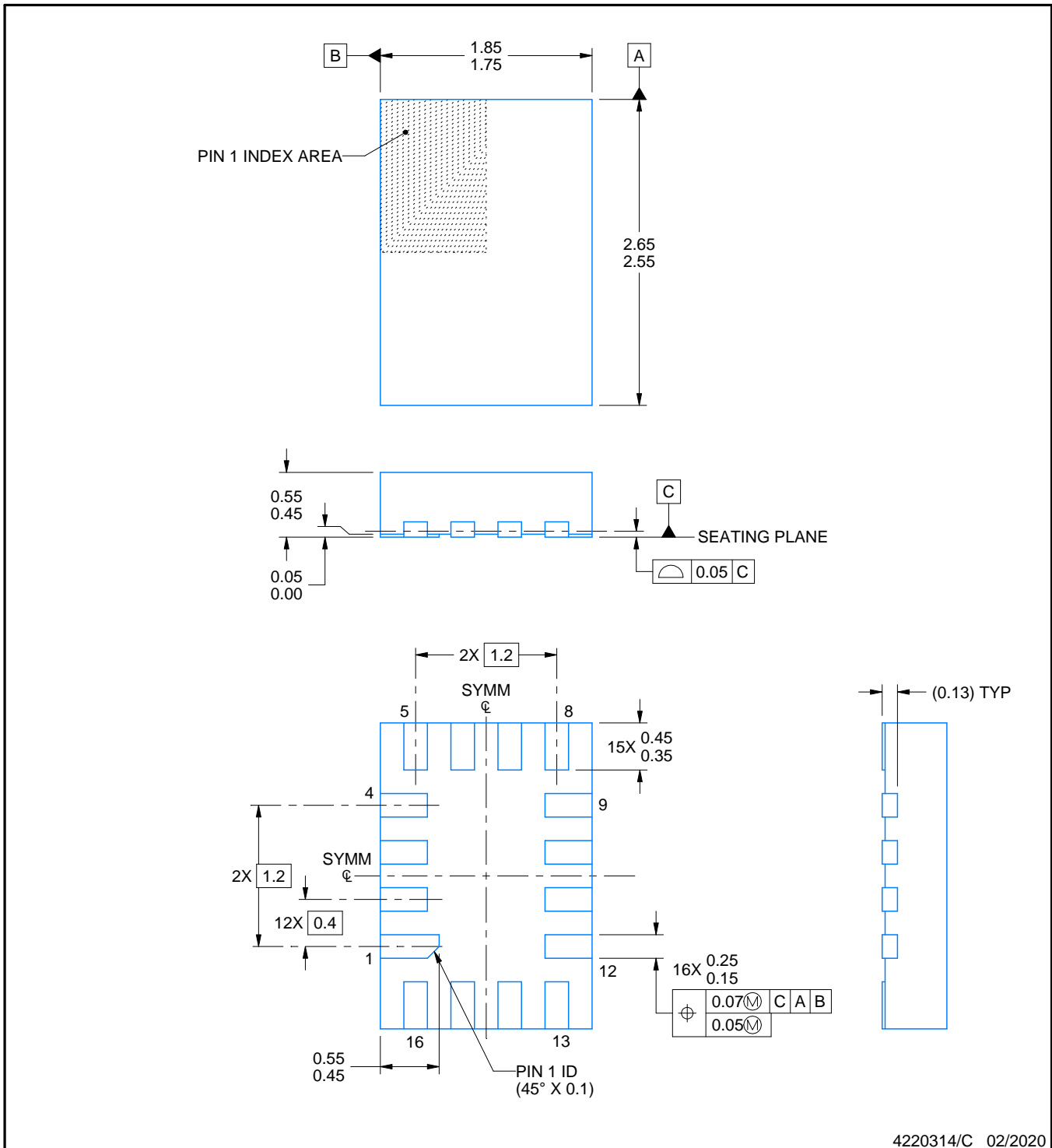
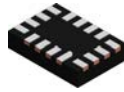

NOTES:

1. All linear dimensions are in millimeters. Any dimensions in parenthesis are for reference only. Dimensioning and tolerancing per ASME Y14.5M.
2. This drawing is subject to change without notice.

EXAMPLE BOARD LAYOUT

RSV0016A

UQFN - 0.55 mm max height

ULTRA THIN QUAD FLATPACK - NO LEAD



LAND PATTERN EXAMPLE
EXPOSED METAL SHOWN
SCALE: 25X



4220314/C 02/2020

NOTES: (continued)

3. For more information, see Texas Instruments literature number SLUA271 (www.ti.com/lit/slua271).

EXAMPLE STENCIL DESIGN

RSV0016A

UQFN - 0.55 mm max height

ULTRA THIN QUAD FLATPACK - NO LEAD



SOLDER PASTE EXAMPLE
BASED ON 0.125 MM THICK STENCIL
SCALE: 25X

4220314/C 02/2020

NOTES: (continued)

4. Laser cutting apertures with trapezoidal walls and rounded corners may offer better paste release. IPC-7525 may have alternate design recommendations.

重要なお知らせと免責事項

テキサス・インスツルメンツは、技術データと信頼性データ(データシートを含みます)、設計リソース(リファレンス デザインを含みます)、アプリケーションや設計に関する各種アドバイス、Web ツール、安全性情報、その他のリソースを、欠陥が存在する可能性のある「現状のまま」提供しており、商品性および特定目的に対する適合性の黙示保証、第三者の知的財産権の非侵害保証を含むいかなる保証も、明示的または黙示的にかかわらず拒否します。

これらのリソースは、テキサス・インスツルメンツ製品を使用する設計の経験を積んだ開発者への提供を意図したものです。(1) お客様のアプリケーションに適したテキサス・インスツルメンツ製品の選定、(2) お客様のアプリケーションの設計、検証、試験、(3) お客様のアプリケーションに該当する各種規格や、その他のあらゆる安全性、セキュリティ、規制、または他の要件への確実な適合に関する責任を、お客様のみが単独で負うものとし、ます。

上記の各種リソースは、予告なく変更される可能性があります。これらのリソースは、リソースで説明されているテキサス・インスツルメンツ製品を使用するアプリケーションの開発の目的でのみ、テキサス・インスツルメンツはその使用をお客様に許諾します。これらのリソースに関して、他の目的で複製することや掲載することは禁止されています。テキサス・インスツルメンツや第三者の知的財産権のライセンスが付与されている訳ではありません。お客様は、これらのリソースを自身で使用した結果発生するあらゆる申し立て、損害、費用、損失、責任について、テキサス・インスツルメンツおよびその代理人を完全に補償するものとし、テキサス・インスツルメンツは一切の責任を拒否します。

テキサス・インスツルメンツの製品は、[テキサス・インスツルメンツの販売条件](#)、または [ti.com](https://www.ti.com) やかかるテキサス・インスツルメンツ製品の関連資料などのいずれかを通じて提供する適用可能な条項の下で提供されています。テキサス・インスツルメンツがこれらのリソースを提供することは、適用されるテキサス・インスツルメンツの保証または他の保証の放棄の拡大や変更を意味するものではありません。

お客様がいかなる追加条項または代替条項を提案した場合でも、テキサス・インスツルメンツはそれらに異議を唱え、拒否します。

郵送先住所：Texas Instruments, Post Office Box 655303, Dallas, Texas 75265
Copyright © 2025, Texas Instruments Incorporated