

# TXS0104V-Q1 オープンドレインおよびプッシュプルアプリケーション向け 車載用 4 ビット双方向レベルシフト電圧トランスレータ

## 1 特長

- 車載アプリケーション認定済み
- 以下の結果で AEC-Q100 認定済み:
  - デバイス温度グレード 1: 動作時周囲温度範囲 40°C~+125°C
  - デバイス HBM ESD 分類レベル 2
  - デバイス CDM ESD 分類レベル C6
- 方向制御信号不要
- 最大データレート:
  - 24Mbps (プッシュプル)
  - 2Mbps (オープンドレイン)
- 1.65V~3.6V (A ポート)、2.3V~5.5V (B ポート) ( $V_{CCA} \leq V_{CCB}$ )
- 電源投入シーケンスが不要 -  $V_{CCA}$  と  $V_{CCB}$  のいずれからでも立ち上げ可能
- JESD 22 を上回る ESD 保護:
  - A ポート:
    - 2000V、人体モデル (A114-B)
    - 500V、デバイス帯電モデル (C101)
  - B ポート:
    - 5000V、人体モデル (A114-B)
    - 500V、デバイス帯電モデル (C101)

## 2 アプリケーション

- 車載インフォテインメント、先進運転支援システム (ADAS)
- メイン プロセッサ モジュールとペリフェラル モジュールの間で絶縁とレベル変換を行います
- I<sup>2</sup>C または 1 線式の電圧レベル変換

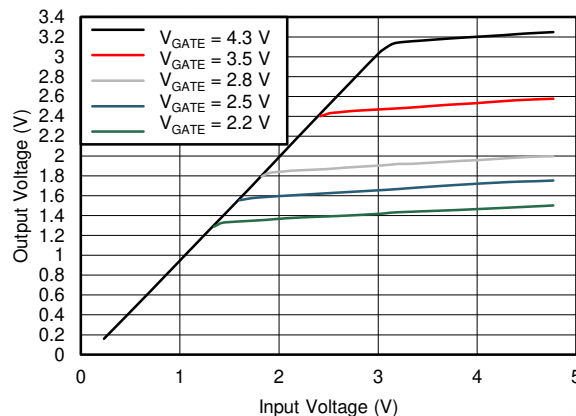

N チャンネル トランジスタの伝達特性

## 3 概要

この 4 ビット非反転トランスレータは、設定可能な 2 つの独立した電源レールを採用しています。A ポートは  $V_{CCA}$  に追従するように設計されています。 $V_{CCA}$  ピンには、1.65V~3.6V の電源電圧を入力できます。 $V_{CCA}$  は  $V_{CCB}$  以下である必要があります。B ポートは、 $V_{CCB}$  に追従する設計になっています。 $V_{CCB}$  ピンには、2.3V~5.5V の電源電圧を入力できます。これにより、1.8V、2.5V、3.3V、5V の任意の電圧ノード間での低電圧双方向変換が可能です。

出力イネーブル (OE) 入力が Low のとき、全出力が高インピーダンス状態になります。

TXS0104V-Q1 は、OE 入力回路が  $V_{CCA}$  によって給電されるように設計されています。

電源投入または電源オフ時の高インピーダンス状態を確保するには、OE をプルダウン抵抗を介して GND に接続します。この抵抗の最小値は、ドライバの電流ソース能力によって決まります。

### パッケージ情報

部品番号	パッケージ (1)	パッケージ サイズ (2)
TXS0104V-Q1	PW (TSSOP, 14)	5mm × 6.4mm
	BQA (WQFN, 12)	3mm × 2.5mm
	RUT (UQFN, 12)	2mm × 1.7mm

- (1) 詳細については、[セクション 11](#) を参照してください。
- (2) パッケージ サイズ (長さ × 幅) は公称値であり、該当する場合はピンも含まれます。



## Table of Contents

<b>1 特長</b> .....	<b>1</b>	7.1 Overview.....	<b>13</b>
<b>2 アプリケーション</b> .....	<b>1</b>	7.2 Functional Block Diagram.....	<b>13</b>
<b>3 概要</b> .....	<b>1</b>	7.3 Feature Description.....	<b>14</b>
<b>4 Pin Configuration and Functions</b> .....	<b>3</b>	7.4 Device Functional Modes.....	<b>14</b>
<b>5 Specifications</b> .....	<b>5</b>	<b>8 Application and Implementation</b> .....	<b>15</b>
5.1 Absolute Maximum Ratings.....	<b>5</b>	8.1 Application Information.....	<b>15</b>
5.2 ESD Ratings.....	<b>5</b>	8.2 Typical Application.....	<b>15</b>
5.3 Recommended Operating Conditions.....	<b>5</b>	8.3 Power Supply Recommendations.....	<b>17</b>
5.4 Thermal Information (PW, BQA, RUT).....	<b>6</b>	8.4 Layout.....	<b>17</b>
5.5 Electrical Characteristics.....	<b>6</b>	<b>9 Device and Documentation Support</b> .....	<b>18</b>
5.6 Switching Characteristics, $V_{CCA} = 1.8 \pm 0.15V$ .....	<b>7</b>	9.1 Documentation Support.....	<b>18</b>
5.7 Switching Characteristics, $V_{CCA} = 2.5 \pm 0.2V$ .....	<b>7</b>	9.2 ドキュメントの更新通知を受け取る方法.....	<b>18</b>
5.8 Switching Characteristics, $V_{CCA} = 3.3 \pm 0.3V$ .....	<b>8</b>	9.3 サポート・リソース.....	<b>18</b>
5.9 Switching Characteristics: $T_{sk}, T_{MAX}$ .....	<b>9</b>	9.4 Trademarks.....	<b>18</b>
5.10 Typical Characteristics.....	<b>9</b>	9.5 静電気放電に関する注意事項.....	<b>18</b>
<b>6 Parameter Measurement Information</b> .....	<b>11</b>	9.6 用語集.....	<b>18</b>
6.1 Load Circuits.....	<b>11</b>	<b>10 Revision History</b> .....	<b>18</b>
6.2 Voltage Waveforms.....	<b>12</b>	<b>11 Mechanical, Packaging, and Orderable Information</b> .....	<b>18</b>
<b>7 Detailed Description</b> .....	<b>13</b>		

## 4 Pin Configuration and Functions

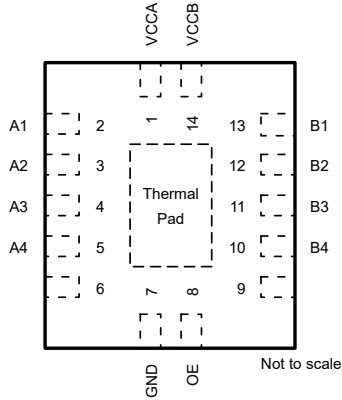

NC - No internal connection

4-1. BQA Package, 14-Pin WQFN (Top View)

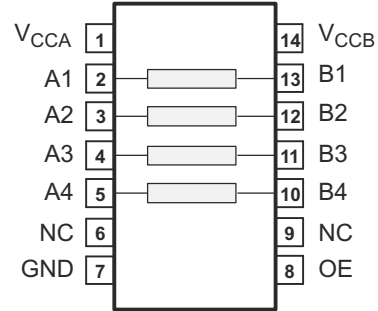

NC - No internal connection

4-2. PW Package, 14-Pin TSSOP (Top View)

表 4-1. Pin Functions: BQA, or PW

PIN		TYPE <sup>(1)</sup>	DESCRIPTION
NAME	NO.		
A1	2	I/O	Input/output A1. Referenced to $V_{CCA}$ .
A2	3	I/O	Input/output A2. Referenced to $V_{CCA}$ .
A3	4	I/O	Input/output A3. Referenced to $V_{CCA}$ .
A4	5	I/O	Input/output A4. Referenced to $V_{CCA}$ .
B1	13	I/O	Input/output B1. Referenced to $V_{CCB}$ .
B2	12	I/O	Input/output B2. Referenced to $V_{CCB}$ .
B3	11	I/O	Input/output B3. Referenced to $V_{CCB}$ .
B4	10	I/O	Input/output B4. Referenced to $V_{CCB}$ .
GND	7	—	Ground
OE	8	I	3-state output-mode enable. Pull OE low to place all outputs in 3-state mode. Referenced to $V_{CCA}$ .
$V_{CCA}$	1	—	A-port supply voltage. $1.65V \leq V_{CCA} \leq 3.6V$ and $V_{CCA} \leq V_{CCB}$ .
$V_{CCB}$	14	—	B-port supply voltage. $2.3V \leq V_{CCB} \leq 5.5V$ .
Thermal Pad		—	For the RGY package, the exposed center thermal pad must be connected to ground

(1) I = input, O = output



図 4-3. RUT Package, 12-Pin UQFN (Transparent Top View)

表 4-2. Pin Functions: RUT

PIN		TYPE <sup>(1)</sup>	DESCRIPTION
NAME	NO.		
A1	2	I/O	Input/output A1. Referenced to $V_{CCA}$ .
A2	3	I/O	Input/output A2. Referenced to $V_{CCA}$ .
A3	4	I/O	Input/output A3. Referenced to $V_{CCA}$ .
A4	5	I/O	Input/output A4. Referenced to $V_{CCA}$ .
B1	10	I/O	Input/output B1. Referenced to $V_{CCB}$ .
B2	9	I/O	Input/output B2. Referenced to $V_{CCB}$ .
B3	8	I/O	Input/output B3. Referenced to $V_{CCB}$ .
B4	7	I/O	Input/output B4. Referenced to $V_{CCB}$ .
GND	6	—	Ground
OE	12	I	3-state output-mode enable. Pull OE low to place all outputs in 3-state mode. Referenced to $V_{CCA}$ .
$V_{CCA}$	1	—	A-port supply voltage. $1.65V \leq V_{CCA} \leq 3.6V$ and $V_{CCA} \leq V_{CCB}$ .
$V_{CCB}$	11	—	B-port supply voltage. $2.3V \leq V_{CCB} \leq 5.5V$ .

(1) I = input, O = output

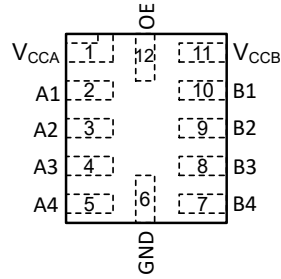
## 5 Specifications

### 5.1 Absolute Maximum Ratings

over operating free-air temperature range (unless otherwise noted)<sup>(1)</sup>

			MIN	MAX	UNIT		
V <sub>CCA</sub>	Supply voltage A		-0.5	4.6	V		
V <sub>CCB</sub>	Supply voltage B		-0.5	6.5	V		
V <sub>I</sub>	Input Voltage <sup>(2)</sup>	I/O Ports (A Port)	-0.5	4.6	V		
		I/O Ports (B Port)	-0.5	6.5			
		OE	-0.5	4.6			
V <sub>O</sub>	Voltage applied to any output in the high-impedance or power-off state <sup>(2)</sup>	A Port	-0.5	4.6	V		
		B Port	-0.5	6.5			
V <sub>O</sub>	Voltage applied to any output in the high or low state <sup>(2) (3)</sup>	A Port	-0.5	V <sub>CCA</sub> + 0.5	V		
		B Port	-0.5	V <sub>CCB</sub> + 0.5			
I <sub>IK</sub>	Input clamp current	V <sub>I</sub> < 0		-50	mA		
I <sub>OK</sub>	Output clamp current	V <sub>O</sub> < 0		-50	mA		
I <sub>O</sub>	Continuous output current			-50	50	mA	
	Continuous current through V <sub>CC</sub> or GND			-100	100	mA	
T <sub>J</sub>	Junction Temperature				150	°C	
T <sub>stg</sub>	Storage temperature				-65	150	°C

- (1) Operation outside the *Absolute Maximum Rating* may cause permanent device damage. *Absolute Maximum Rating* do not imply functional operation of the device at these or any other conditions beyond those listed under *Recommended Operating Condition*. If used outside the *Recommended Operating Condition* but within the *Absolute Maximum Rating*, the device may not be fully functional, and this may affect device reliability, functionality, performance, and shorten the device lifetime.
- (2) The input voltage and output negative-voltage ratings may be exceeded if the input and output current ratings are observed.
- (3) The output positive-voltage rating may be exceeded up to 6.5V maximum if the output current rating is observed.

### 5.2 ESD Ratings

			VALUE	UNIT
V <sub>(ESD)</sub>	Electrostatic discharge	Human body model (HBM), per AEC Q100-002 <sup>(1)</sup>	±2500	V
		Charged device model (CDM), per AEC Q100-011	±1500	

- (1) AEC Q100-002 indicates that HBM stressing shall be in accordance with the ANSI/ESDA/JEDEC JS-001 specification

### 5.3 Recommended Operating Conditions

over operating free-air temperature range (unless otherwise noted) <sup>(1) (2) (3)</sup>

		V <sub>CCA</sub>	V <sub>CCB</sub>	MIN	MAX	UNIT		
V <sub>CCA</sub>	Supply voltage A			1.65	3.6	V		
V <sub>CCB</sub>	Supply voltage B			2.3	5.5	V		
V <sub>IH</sub>	High-level input voltage	A-port I/O's	1.65V to 1.95V	2.3V to 5.5V	V <sub>CCI</sub> - 0.2	V <sub>CCI</sub>	V	
			2.3V to 3.6V	2.3V to 5.5V	V <sub>CCI</sub> - 0.4	V <sub>CCI</sub>		
		B-port I/O's	1.65V to 3.6V	2.3V to 5.5V	V <sub>CCI</sub> - 0.4	V <sub>CCI</sub>		
			OE Input	1.65V to 3.6V	2.3V to 5.5V	V <sub>CCA</sub> × 0.65		5.5
V <sub>IL</sub>	Low-level input voltage	A-port I/O's	1.65V to 3.6V	2.3V to 5.5V		0.2	V	
		B-port I/O's	1.65V to 3.6V	2.3V to 5.5V		0.2		
		OE Input	1.65V to 3.6V	2.3V to 5.5V		V <sub>CCA</sub> × 0.35		
Δt/Δv	Input transition rise and fall time	Push-Pull Driving	1.65V to 3.6V	2.3V to 5.5V		10	ns/V	
T <sub>A</sub>	Operating free-air temperature					-40	125	°C

- (1) V<sub>CCI</sub> is the V<sub>CC</sub> associated with the input port.
- (2) V<sub>CCO</sub> is the V<sub>CC</sub> associated with the output port.
- (3) All control inputs and data I/Os of this device have weak pulldowns to ensure the line is not floating when undefined external to the device. The input leakage from these weak pulldowns is defined by the I<sub>I</sub> specification indicated under [Electrical Characteristics](#).

## 5.4 Thermal Information (PW, BQA, RUT)

THERMAL METRIC <sup>(1)</sup>		TXS0104V-Q1	TXS0104V-Q1	TXS0104V-Q1	UNIT
		PW (TSSOP)	BQA (WQFN)	RUT (UQFN)	
		14 PINS	14 PINS	12 PINS	
$R_{\theta JA}$	Junction-to-ambient thermal resistance	115.2	73.5	150.4	°C/W
$R_{\theta JC(top)}$	Junction-to-case (top) thermal resistance	46.2	76.9	68.6	°C/W
$R_{\theta JB}$	Junction-to-board thermal resistance	70.9	43.0	76.3	°C/W
$Y_{JT}$	Junction-to-top characterization parameter	3.4	4.7	2.4	°C/W
$Y_{JB}$	Junction-to-board characterization parameter	70.2	42.9	76.2	°C/W
$R_{\theta JC(bottom)}$	Junction-to-case (bottom) thermal resistance	N/A	19.6	N/A	°C/W

(1) For more information about traditional and new thermal metrics, see the [Semiconductor and IC Package Thermal Metrics](#) application report.

## 5.5 Electrical Characteristics

over operating free-air temperature range (unless otherwise noted)<sup>(1) (2)</sup>

PARAMETER	TEST CONDITIONS	$V_{CCA}$	$V_{CCB}$	Operating free-air temperature ( $T_A$ )									UNIT	
				25°C			–40°C to 85°C			–40°C to 125°C				
				MIN	TYP	MAX	MIN	TYP	MAX	MIN	TYP	MAX		
$V_{OHA}$	Port A output high voltage <sup>(3)</sup>	$I_{OH} = -20\mu A$	1.65V to 3.6V	1.65V to 5.5V	$V_{CCA} \times 0.8$			$V_{CCA} \times 0.8$			$V_{CCA} \times 0.8$			V
			1.65V to 3.6V	1.65V to 5.5V	$V_{CCA} \times 0.8$			$V_{CCA} \times 0.8$			$V_{CCA} \times 0.8$			
$V_{OHB}$	Port B output high voltage	$I_{OH} = -20\mu A$	1.65V to 3.6V	1.65V to 5.5V	$V_{CCB} \times 0.8$			$V_{CCB} \times 0.8$			$V_{CCB} \times 0.8$			V
			1.65V to 3.6V	1.65V to 5.5V	$V_{CCB} \times 0.8$			$V_{CCB} \times 0.8$			$V_{CCB} \times 0.8$			
$V_{OL}$	Low-level output voltage <sup>(4)</sup>	$I_{OL} = 1mA$	1.65V to 3.6V	1.65V to 5.5V	0.4			0.4			0.4			V
$I_I$	Input leakage current	OE $V_I = V_{CC}$ or GND	1.65V to 3.6V	1.65V to 5.5V	-2	2	-2	2	-2	2	2	$\mu A$		
$I_{OZ}$	Tri-state output current	A or B Port: $V_I = V_{CC1}$ or GND $V_O = V_{CC0}$ or GND OE = GND	1.65V to 3.6V	1.65V to 5.5V	-1	1	-2	2	-3	3	3	$\mu A$		
$I_{CCA}$	$V_{CCA}$ supply current	$V_I = V_{CC1}$ or GND $I_O = 0$	1.65V to $V_{CCB}$	2.3V to 5.5V	2.4			3.3			6.2			$\mu A$
			0V	5.5V	-3			-3						
			3.6V	0V	2.2			2.2			2.2			
$I_{CCB}$	$V_{CCB}$ supply current	$V_I = V_{CC1}$ or GND $I_O = 0$	1.65V to $V_{CCB}$	2.3V to 5.5V	12			12			21			$\mu A$
			0V	5.5V	5			5			8			
			3.6V	0V	-1			-1			-1			
$I_{CCA} + I_{CCB}$	Combined supply current	$V_I = V_{CC1}$ or GND $I_O = 0$	1.65V to $V_{CCB}$	2.3V to 5.5V	14.4			14.4			25			$\mu A$
$C_i$	Control Input Capacitance	$V_I = 3.3V$ or GND	3.3V	3.3V	6			6			6			pF
$C_{io}$	Data I/O Capacitance	A or B Port:	3.3V	3.3V	5 6.5			12 16.5			12 16.5			pF

- (1)  $V_{CC1}$  is the  $V_{CC}$  associated with the input port  
(2)  $V_{CC0}$  is the  $V_{CC}$  associated with the output port  
(3) Tested at  $V_I = V_{T+(MAX)}$

(4) Tested at  $V_I = V_{T-(MIN)}$

### 5.6 Switching Characteristics, $V_{CCA} = 1.8 \pm 0.15V$

over operating free-air temperature range (unless otherwise noted)

PARAMETER		FROM	TO	Test Conditions	B-Port Supply Voltage ( $V_{CCB}$ )						UNIT			
					2.5 ± 0.2V			3.3 ± 0.3V				5.0 ± 0.5V		
					MIN	TYP	MAX	MIN	TYP	MAX		MIN	TYP	MAX
$t_{PHL}$	Propagation Delay (High-to-Low)	A	B	Push-Pull	4			4			5			ns
$t_{PHL}$	Propagation Delay (High-to-Low)			Open-Drain	8.8			9.6			10			ns
$t_{PLH}$	Propagation Delay (Low-to-High)			Push-Pull	6			6			6			ns
$t_{PLH}$	Propagation Delay (Low-to-High)			Open-Drain	200			160			120			ns
$t_{PHL}$	Propagation Delay (High-to-Low)	B	A	Push-Pull	4			4			4			ns
$t_{PHL}$	Propagation Delay (High-to-Low)			Open-Drain	5.3			4.4			4.1			ns
$t_{PLH}$	Propagation Delay (Low-to-High)			Push-Pull	5			4			4			ns
$t_{PLH}$	Propagation Delay (Low-to-High)			Open-Drain	173			120			90			ns
$t_{en}$	Enable Time	OE	A or B	-40°C to 125°C	200			200			200			ns
$t_{dis}$	Disable Time	OE	A or B	-40°C to 125°C	250			250			250			ns
$t_{rA}$	Output Rise Time	B	A	Push-Pull	9			9			7			ns
$t_{rA}$	Output Rise Time			Open-Drain	150			120			80			ns
$t_{rB}$	Output Rise Time	A	B	Push-Pull	10			9			7			ns
$t_{rB}$	Output Rise Time			Open-Drain	145			106			58			ns
$t_{fA}$	Output Fall Time	B	A	Push-Pull	5			5			5			ns
$t_{fA}$	Output Fall Time			Open-Drain	6			6			6			ns
$t_{fB}$	Output Fall Time	A	B	Push-Pull	7			7			8			ns
$t_{fB}$	Output Fall Time			Open-Drain	13			16			16			ns

### 5.7 Switching Characteristics, $V_{CCA} = 2.5 \pm 0.2V$

over operating free-air temperature range (unless otherwise noted)

PARAMETER		FROM	TO	Test Conditions	B-Port Supply Voltage ( $V_{CCB}$ )						UNIT			
					2.5 ± 0.2V			3.3 ± 0.3V				5.0 ± 0.5V		
					MIN	TYP	MAX	MIN	TYP	MAX		MIN	TYP	MAX
$t_{PHL}$	Propagation Delay (High-to-Low)	A	B	Push-Pull	3			3.4			5			ns
$t_{PHL}$	Propagation Delay (High-to-Low)			Open-Drain	6.3			6			5.8			ns
$t_{PHL}$	Propagation Delay (High-to-Low)			Push-Pull	3			4			4			ns
$t_{PHL}$	Propagation Delay (High-to-Low)			Open-Drain	200			160			120			ns
$t_{PHL}$	Propagation Delay (High-to-Low)	B	A	Push-Pull	3			3			4			ns
$t_{PHL}$	Propagation Delay (High-to-Low)			Open-Drain	4.7			4.2			4			ns
$t_{PHL}$	Propagation Delay (High-to-Low)			Push-Pull	2.1			2			1.9			ns
$t_{PHL}$	Propagation Delay (High-to-Low)			Open-Drain	173			120			90			ns

### 5.7 Switching Characteristics, $V_{CCA} = 2.5 \pm 0.2V$ (続き)

over operating free-air temperature range (unless otherwise noted)

PARAMETER		FROM	TO	Test Conditions	B-Port Supply Voltage ( $V_{CCB}$ )						UNIT			
					2.5 ± 0.2V			3.3 ± 0.3V				5.0 ± 0.5V		
					MIN	TYP	MAX	MIN	TYP	MAX		MIN	TYP	MAX
$t_{en}$	Enable Time	OE	A or B	-40°C to 125°C	200			200			200			ns
$t_{dis}$	Disable Time	OE	A or B	-40°C to 125°C	250			250			250			ns
$t_{rA}$	Output Rise Time	B	A	Push-Pull	7			6			5			ns
$t_{rA}$	Output Rise Time			Open-Drain	149			101			63			ns
$t_{rB}$	Output Rise Time	A	B	Push-Pull	8			7			6			ns
$t_{rB}$	Output Rise Time			Open-Drain	150			101			63			ns
$t_{fA}$	Output Fall Time	B	A	Push-Pull	5.1			5.2			5			ns
$t_{fA}$	Output Fall Time			Open-Drain	6			6			5			ns
$t_{fB}$	Output Fall Time	A	B	Push-Pull	7			6.4			8.7			ns
$t_{fB}$	Output Fall Time			Open-Drain	8			9			10			ns

### 5.8 Switching Characteristics, $V_{CCA} = 3.3 \pm 0.3V$

over operating free-air temperature range (unless otherwise noted)

PARAMETER		FROM	TO	Test Conditions	B-Port Supply Voltage ( $V_{CCB}$ )						UNIT
					3.3 ± 0.3V			5.0 ± 0.5V			
					MIN	TYP	MAX	MIN	TYP	MAX	
$t_{PHL}$	Propagation Delay (Hight-to-Low)	A	B	Push-Pull	2.4			3.1			ns
$t_{PHL}$	Propagation Delay (Hight-to-Low)			Open-Drain	4.2			4.6			
$t_{PLH}$	Propagation Delay (Low-to-High)			Push-Pull	4.2			4.4			
$t_{PLH}$	Propagation Delay (Low-to-High)			Open-Drain	160			120			
$t_{PHL}$	Propagation Delay (Hight-to-Low)	B	A	Push-Pull	2.5			3.3			ns
$t_{PHL}$	Propagation Delay (Hight-to-Low)			Open-Drain	4.5			4			ns
$t_{PLH}$	Propagation Delay (Low-to-High)			Push-Pull	2.5			2.6			ns
$t_{PLH}$	Propagation Delay (Low-to-High)			Open-Drain	139			105			ns
$t_{en}$	Enable Time	OE	A or B	-40°C to 125°C	200			200			ns
$t_{dis}$	Disable Time	OE	A or B	-40°C to 125°C	250			250			ns
$t_{rA}$	Output Rise Time	B	A	Push-Pull	5			4			ns
$t_{rA}$	Output Rise Time			Open-Drain	116			85			ns
$t_{rB}$	Output Rise Time	A	B	Push-Pull	6			7			ns
$t_{rB}$	Output Rise Time			Open-Drain	116			116			ns
$t_{fA}$	Output Fall Time	B	A	Push-Pull	8			7.6			ns
$t_{fA}$	Output Fall Time			Open-Drain	6			5			ns
$t_{fB}$	Output Fall Time	A	B	Push-Pull	8.2			10.8			ns
$t_{fB}$	Output Fall Time			Open-Drain	7			8			ns



### 5.9 Switching Characteristics: $T_{sk}$ , $T_{MAX}$

over operating free-air temperature range (unless otherwise noted)

PARAMETER	TEST CONDITIONS	$V_{CCA}$	$V_{CCB}$	Operating free-air temperature ( $T_A$ )			UNIT
				-40°C to 125°C			
				MIN	TYP	MAX	
TMAX - Maximum Data Rate	50% Duty Cycle Input One channel switching	Push-Pull Driving	1.8 ± 0.15V	2.5V ± 0.2V		18	Mbps
			1.8 ± 0.15V	3.3V ± 0.3V		21	
			1.8 ± 0.15V	5V ± 0.5V		23	
TMAX - Maximum Data Rate	50% Duty Cycle Input One channel switching	Push-Pull Driving	2.5V ± 0.2V	2.5V ± 0.2V		20	Mbps
			2.5V ± 0.2V	3.3V ± 0.3V		22	
			2.5V ± 0.2V	5V ± 0.5V		24	
TMAX - Maximum Data Rate	50% Duty Cycle Input One channel switching	Push-Pull Driving	3.3V ± 0.3V	3.3V ± 0.3V		22	Mbps
			3.3V ± 0.3V	5V ± 0.5V		24	
TMAX - Maximum Data Rate	50% Duty Cycle Input One channel switching	Open-Drain Driving	1.8 ± 0.15V	2.5V ± 0.2V		2	Mbps
			1.8 ± 0.15V	3.3V ± 0.3V		2	
			1.8 ± 0.15V	5V ± 0.5V		2	
TMAX - Maximum Data Rate	50% Duty Cycle Input One channel switching	Open-Drain Driving	2.5V ± 0.2V	2.5V ± 0.2V		2	Mbps
			2.5V ± 0.2V	3.3V ± 0.3V		2	
			2.5V ± 0.2V	5V ± 0.5V		2	
TMAX - Maximum Data Rate	50% Duty Cycle Input One channel switching	Open-Drain Driving	3.3V ± 0.3V	3.3V ± 0.3V		2	Mbps
			3.3V ± 0.3V	5V ± 0.5V		2	
$t_w$	Pulse Duration, Data Inputs	Push-Pull Driving	1.65V to 3.3V	2.3V to 5.5V	41		ns
			Open-Drain Driving	1.65V to 3.3V	2.3V to 5.5V	500	
$t_{sk}$ - Output skew	Skew between any two outputs of the same package switching in the same direction	Push-Pull Driving	1.65V to 3.3V	2.3V to 5.5V		1	ns
			Open-Drain Driving	1.65V to 3.3V	2.3V to 5.5V		

### 5.10 Typical Characteristics

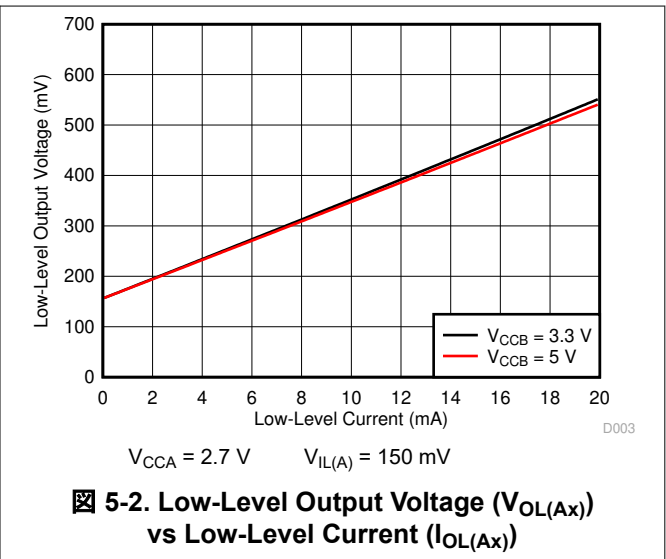
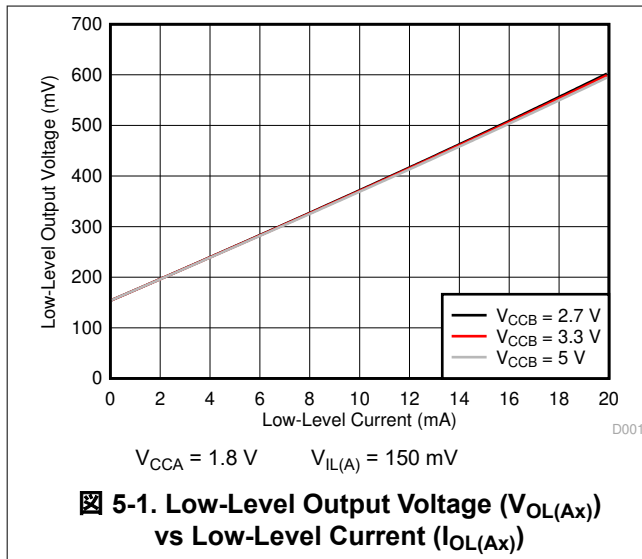



図 5-3. Low-Level Output Voltage ( $V_{OL(Ax)}$ ) vs Low-Level Current ( $I_{OL(Ax)}$ )

## 6 Parameter Measurement Information

### 6.1 Load Circuits

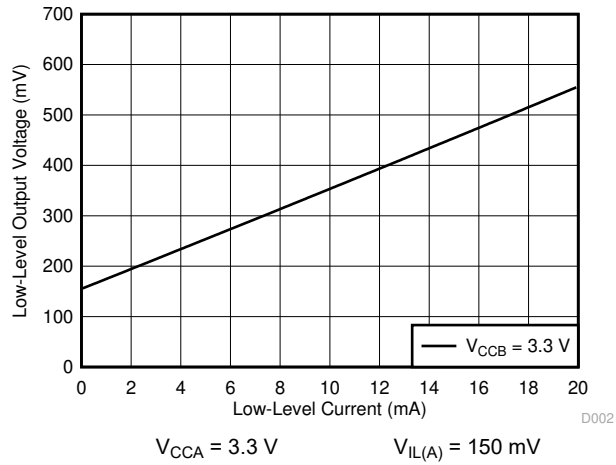
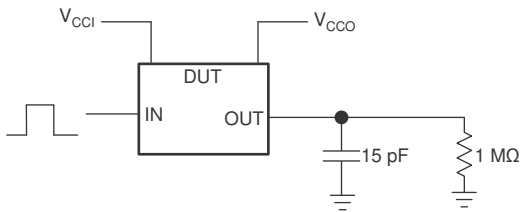

☒ 6-1. Data Rate, Pulse Duration, Propagation Delay, Output Rise-Time and Fall-Time Measurement Using a Push-Pull Driver

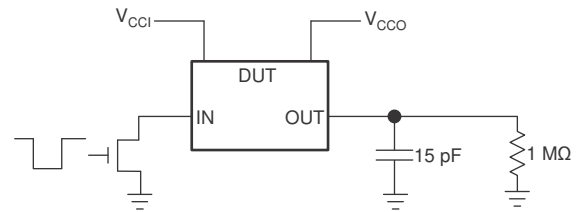

☒ 6-2. Data Rate, Pulse Duration, Propagation Delay, Output Rise-Time and Fall-Time Measurement Using an Open-Drain Driver

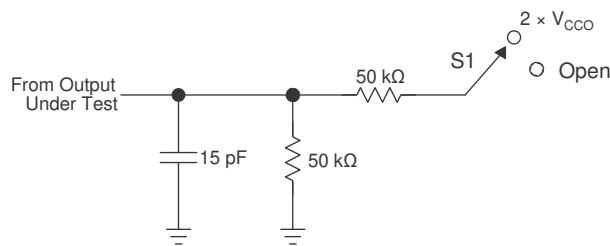

TEST	S1
$t_{PZL} / t_{PLZ}$ ( $t_{dis}$ )	$2 \times V_{CCO}$
$t_{PHZ} / t_{PZH}$ ( $t_{en}$ )	Open

☒ 6-3. Load Circuit for Enable-Time and Disable-Time Measurement

1.  $t_{PLZ}$  and  $t_{PHZ}$  are the same as  $t_{dis}$ .
2.  $t_{PZL}$  and  $t_{PZH}$  are the same as  $t_{en}$ .
3.  $V_{CCI}$  is the  $V_{CC}$  associated with the input port.
4.  $V_{CCO}$  is the  $V_{CC}$  associated with the output port.

## 6.2 Voltage Waveforms

The outputs are measured one at a time, with one transition per measurement. All input pulses are supplied by generators that have the following characteristics:

- $PRR \leq 10\text{MHz}$
- $Z_O = 50\Omega$
- $dv/dt \geq 1\text{V/ns}$

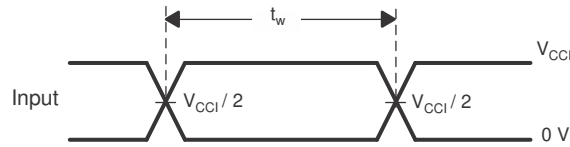

Figure 6-4. Pulse Duration

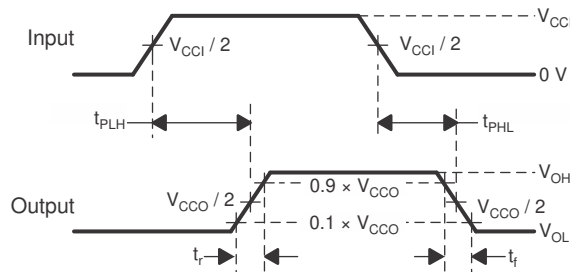
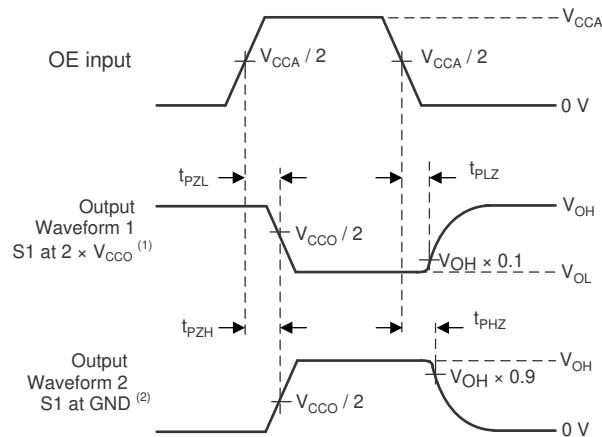

Figure 6-5. Propagation Delay Times



- A. Waveform 1 is for an output with internal such that the output is high, except when OE is high (see Figure 6-3).  
 B. Waveform 2 is for an output with conditions such that the output is low, except when OE is high.

Figure 6-6. Enable and Disable Times

## 7 Detailed Description

### 7.1 Overview

The TXS0104V-Q1 device is a directionless voltage-level translator specifically designed for translating logic voltage levels. The A port is able to accept I/O voltages ranging from 1.65V to 3.6V, while the B port can accept I/O voltages from 2.3V to 5.5V. The device is a pass gate architecture with edge rate accelerators (one shots) to improve the overall data rate. 10kΩ pullup resistors, commonly used in open drain applications, have been conveniently integrated so that an external resistor is not needed. While this device is designed for open drain applications, the device can also translate push-pull CMOS logic outputs.

### 7.2 Functional Block Diagram

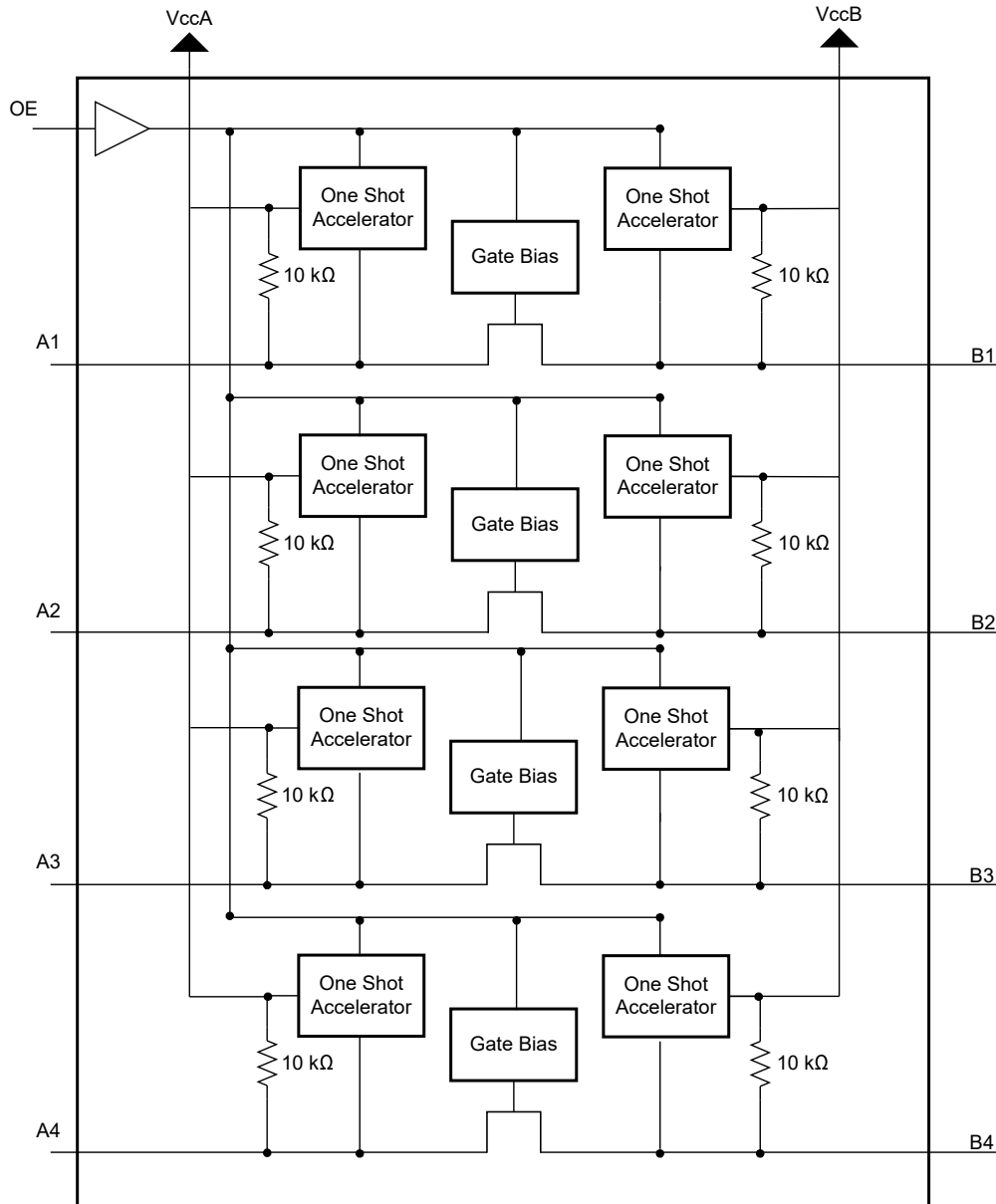

## 7.3 Feature Description

### 7.3.1 Architecture

The TXS0104V-Q1 architecture (see [Figure 7-1](#)) does not require a direction-control signal to control the direction of data flow from A to B or from B to A.

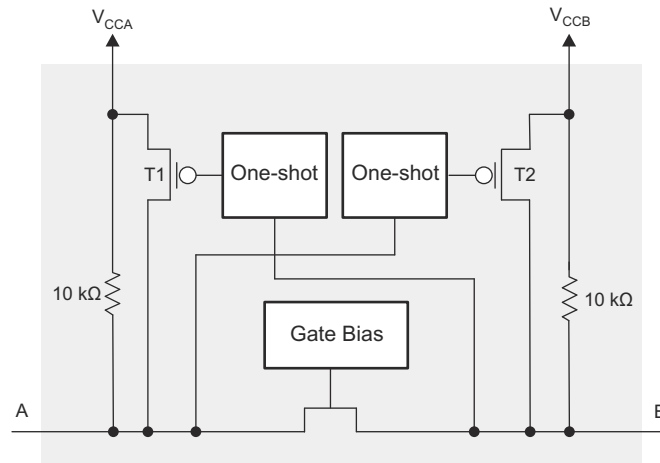

**Figure 7-1. Architecture of a TXS0104V-Q1 Cell**

Each A-port I/O has an internal 10kΩ pullup resistor to  $V_{CCA}$ , and each B-port I/O has an internal 10kΩ pullup resistor to  $V_{CCB}$ . The output one-shots detect rising edges on the A or B ports. During a rising edge, the one-shot turns on the PMOS transistors (T1 and T2) for a short duration which speeds up the low-to-high transition.

### 7.3.2 Input Driver Requirements

The fall time ( $t_{fA}$  and  $t_{fB}$ ) of a signal depends on the output impedance of the external device driving the data I/Os of the TXS0104V-Q1 device. Similarly, the  $t_{PHL}$  and maximum data rates also depend on the output impedance of the external driver. The values for  $t_{fA}$ ,  $t_{fB}$ ,  $t_{PHL}$ , and maximum data rates in the data sheet assume that the output impedance of the external driver is less than 50Ω.

### 7.3.3 Power Up

During operation, ensure that  $V_{CCA} \leq V_{CCB}$  at all times. During power-up sequencing,  $V_{CCA} \geq V_{CCB}$  does not damage the device, so any power supply can be ramped up first.

### 7.3.4 Enable and Disable

The TXS0104V-Q1 device has an OE input that disables the device by setting OE low, which places all I/Os in the high-impedance state. The disable time ( $t_{dis}$ ) indicates the delay between the time when the OE pin goes low and when the outputs actually enter the high-impedance state. The enable time ( $t_{en}$ ) indicates the amount of time the user must allow for the one-shot circuitry to become operational after the OE pin is taken high.

### 7.3.5 Pullup and Pulldown Resistors on I/O Lines

Each A-port I/O has an internal 10kΩ pullup resistor to  $V_{CCA}$ , and each B-port I/O has an internal 10kΩ pullup resistor to  $V_{CCB}$ . If a smaller value of pullup resistor is required, an external resistor must be added from the I/O to  $V_{CCA}$  or  $V_{CCB}$  (in parallel with the internal 10kΩ resistors).

## 7.4 Device Functional Modes

The TXS0104V-Q1 device has two functional modes: enabled and disabled. To disable the device set the OE input low, which places all I/Os in a high impedance state. Setting the OE input high will enable the device.

## 8 Application and Implementation

### 注

Information in the following applications sections is not part of the TI component specification, and TI does not warrant its accuracy or completeness. TI's customers are responsible for determining suitability of components for their purposes, as well as validating and testing their design implementation to confirm system functionality.

### 8.1 Application Information

The TXS0104V-Q1 device can be used in level-translation applications for interfacing devices or systems operating at different interface voltages with one another. The TXS0104V-Q1 device is an excellent choice for applications where an open-drain driver is connected to the data I/Os. The TXS0104V-Q1 device can also be used in applications where a push-pull driver is connected to the data I/Os, but the TXB0104 device might be a better option for such push-pull applications.

### 8.2 Typical Application



図 8-1. Application Schematic

#### 8.2.1 Design Requirements

For this design example, use the parameters listed in [表 8-1](#).

表 8-1. Design Parameters

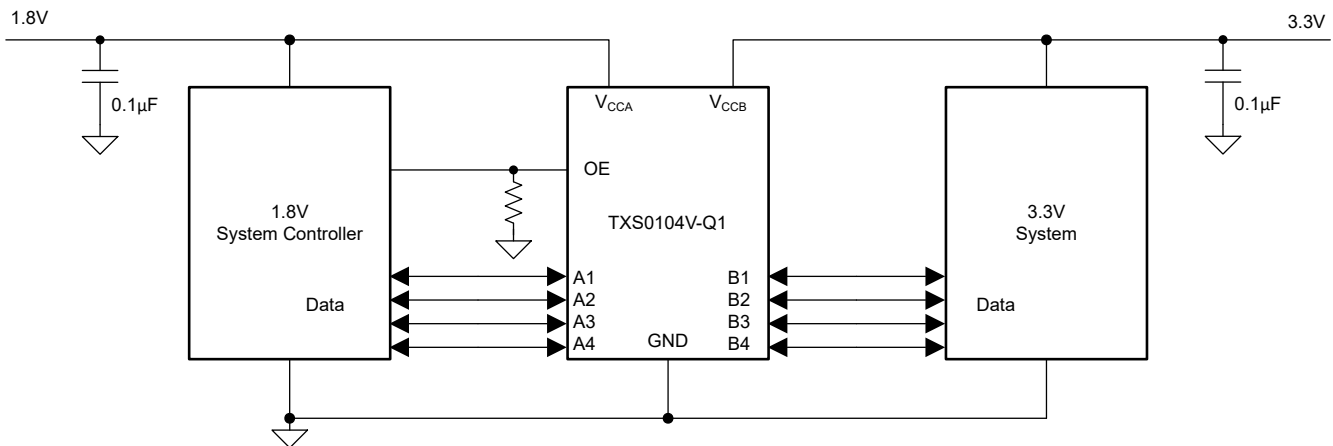
DESIGN PARAMETER	EXAMPLE VALUE
Input voltage range	1.65 to 3.6V
Output voltage range	2.3 to 5.5V

### 8.2.2 Detailed Design Procedure

To begin the design process, determine the following:

- Input voltage range
  - Use the supply voltage of the device that is driving the TXS0104V-Q1 device to determine the input voltage range. For a valid logic high the value must exceed the  $V_{IH}$  of the input port. For a valid logic low the value must be less than the  $V_{IL}$  of the input port.
- Output voltage range
  - Use the supply voltage of the device that the TXS0104V-Q1 device is driving to determine the output voltage range.
  - The TXS0104V-Q1 device has 10kΩ internal pullup resistors. External pullup resistors can be added to reduce the total RC of a signal trace if necessary.
- An external pull down resistor decreases the output  $V_{OH}$  and  $V_{OL}$ . Use 式 1 to calculate the  $V_{OH}$  as a result of an external pull down resistor.

$$V_{OH} = V_{CCx} \times R_{PD} / (R_{PD} + 10\text{ k}\Omega) \tag{1}$$

where

$V_{CCx}$  is the supply voltage on either  $V_{CCA}$  or  $V_{CCB}$   
 $R_{PD}$  is the value of the external pull down resistor

### 8.2.3 Application Curve

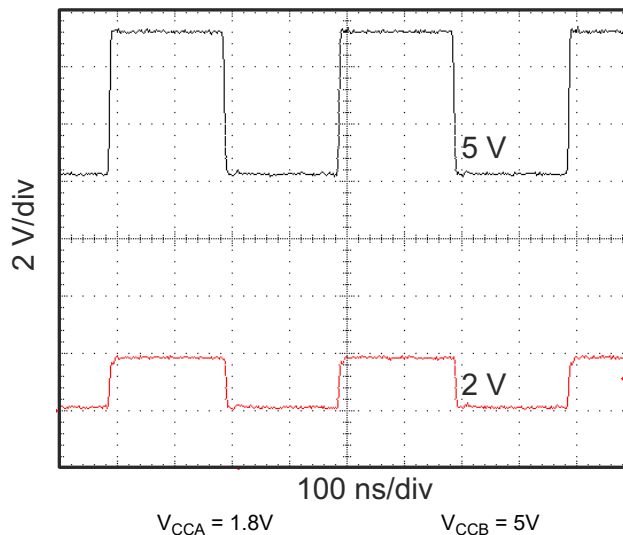

**図 8-2. Level-Translation of a 2.5MHz Signal**



### 8.3 Power Supply Recommendations

The TXS0104V-Q1 device uses two separate configurable power-supply rails,  $V_{CCA}$  and  $V_{CCB}$ .  $V_{CCB}$  accepts any supply voltage from 2.3V to 5.5V and  $V_{CCA}$  accepts any supply voltage from 1.65V to 3.6V as long as  $V_S$  is less than or equal to  $V_{CCB}$ . The A port and B port are designed to track  $V_{CCA}$  and  $V_{CCB}$  respectively allowing for low-voltage bidirectional translation between any of the 1.8V, 2.5V, 3.3V, and 5V voltage nodes.

The TXS0104V-Q1 device does not require power sequencing between  $V_{CCA}$  and  $V_{CCB}$  during power-up so the power-supply rails can be ramped in any order. A  $V_{CCA}$  value greater than or equal to  $V_{CCB}$  ( $V_{CCA} \geq V_{CCB}$ ) does not damage the device, but during operation,  $V_{CCA}$  must be less than or equal to  $V_{CCB}$  ( $V_{CCA} \leq V_{CCB}$ ) at all times.

The output-enable (OE) input circuit is designed so that it is supplied by  $V_{CCA}$  and when the (OE) input is low, all outputs are placed in the high-impedance state. For the high-impedance state of the outputs during power up or power down, the OE input pin must be tied to GND through a pulldown resistor and must not be enabled until  $V_{CCA}$  and  $V_{CCB}$  are fully ramped and stable. The current-sourcing capability of the driver determines the minimum value of the pulldown resistor to ground.

### 8.4 Layout

#### 8.4.1 Layout Guidelines

For device reliability, it is recommended to follow common printed-circuit board layout guidelines such as follows:

- Bypass capacitors should be used on power supplies.
- Short trace lengths should be used to avoid excessive loading.
- PCB signal trace-lengths must be kept short enough so that the round-trip delay of any reflection is less than the one shot duration, approximately 30ns, and encounters low impedance at the source driver.
- Placing pads on the signal paths for loading capacitors or pullup resistors to help adjust rise and fall times of signals depending on the system requirements

#### 8.4.2 Layout Example

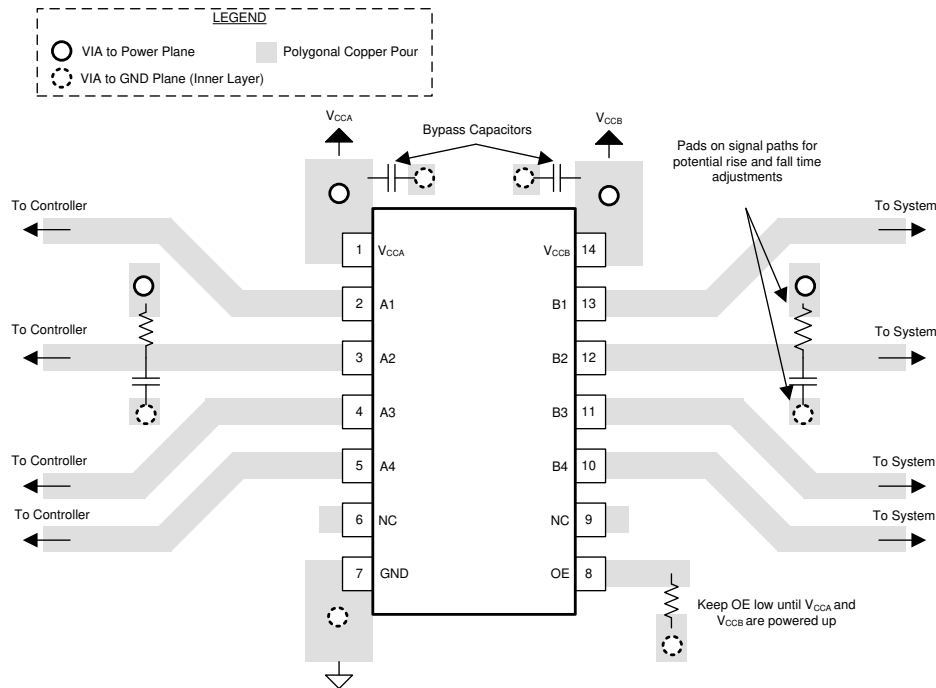

**8-3. TXS0104V-Q1 Layout Example**

## 9 Device and Documentation Support

### 9.1 Documentation Support

#### 9.1.1 Related Documentation

For related documentation, see the following:

- Texas Instruments, [Effects of External Pullup and Pulldown Resistors on TXS and TXB Devices application report](#)
- Texas Instruments, [Basics of Voltage Translation application report](#)
- Texas Instruments, [A Guide to Voltage Translation With TXS-Type Translators application report](#)

### 9.2 ドキュメントの更新通知を受け取る方法

ドキュメントの更新についての通知を受け取るには、[www.tij.co.jp](http://www.tij.co.jp) のデバイス製品フォルダを開いてください。[通知] をクリックして登録すると、変更されたすべての製品情報に関するダイジェストを毎週受け取ることができます。変更の詳細については、改訂されたドキュメントに含まれている改訂履歴をご覧ください。

### 9.3 サポート・リソース

テキサス・インスツルメンツ E2E™ サポート・フォーラムは、エンジニアが検証済みの回答と設計に関するヒントをエキスパートから迅速かつ直接得ることができる場所です。既存の回答を検索したり、独自の質問をしたりすることで、設計に必要な支援を迅速に得ることができます。

リンクされているコンテンツは、各寄稿者により「現状のまま」提供されるものです。これらはテキサス・インスツルメンツの仕様を構成するものではなく、必ずしもテキサス・インスツルメンツの見解を反映したものではありません。テキサス・インスツルメンツの[使用条件](#)を参照してください。

### 9.4 Trademarks

テキサス・インスツルメンツ E2E™ is a trademark of Texas Instruments.

すべての商標は、それぞれの所有者に帰属します。

### 9.5 静電気放電に関する注意事項



この IC は、ESD によって破損する可能性があります。テキサス・インスツルメンツは、IC を取り扱う際には常に適切な注意を払うことを推奨します。正しい取り扱いおよび設置手順に従わない場合、デバイスを破損するおそれがあります。

ESD による破損は、わずかな性能低下からデバイスの完全な故障まで多岐にわたります。精密な IC の場合、パラメータがわずかに変化するだけで公表されている仕様から外れる可能性があるため、破損が発生しやすくなっています。

### 9.6 用語集

[テキサス・インスツルメンツ用語集](#) この用語集には、用語や略語の一覧および定義が記載されています。

## 10 Revision History

DATE	REVISION	NOTES
June 2024	*	Initial Release

## 11 Mechanical, Packaging, and Orderable Information

The following pages include mechanical, packaging, and orderable information. This information is the most current data available for the designated devices. This data is subject to change without notice and revision of this document. For browser-based versions of this data sheet, refer to the left-hand navigation.

## 重要なお知らせと免責事項

テキサス・インスツルメンツは、技術データと信頼性データ (データシートを含みます)、設計リソース (リファレンス デザインを含みます)、アプリケーションや設計に関する各種アドバイス、Web ツール、安全性情報、その他のリソースを、欠陥が存在する可能性のある「現状のまま」提供しており、商品性および特定目的に対する適合性の黙示保証、第三者の知的財産権の非侵害保証を含むいかなる保証も、明示的または黙示的にかかわらず拒否します。

これらのリソースは、テキサス・インスツルメンツ製品を使用する設計の経験を積んだ開発者への提供を意図したものです。(1) お客様のアプリケーションに適した テキサス・インスツルメンツ製品の選定、(2) お客様のアプリケーションの設計、検証、試験、(3) お客様のアプリケーションに該当する各種規格や、その他のあらゆる安全性、セキュリティ、規制、または他の要件への確実な適合に関する責任を、お客様のみが単独で負うものとします。

上記の各種リソースは、予告なく変更される可能性があります。これらのリソースは、リソースで説明されている テキサス・インスツルメンツ製品を使用するアプリケーションの開発の目的でのみ、テキサス・インスツルメンツはその使用をお客様に許諾します。これらのリソースに関して、他の目的で複製することや掲載することは禁止されています。テキサス・インスツルメンツや第三者の知的財産権のライセンスが付与されている訳ではありません。お客様は、これらのリソースを自身で使用した結果発生するあらゆる申し立て、損害、費用、損失、責任について、テキサス・インスツルメンツおよびその代理人を完全に補償するものとし、テキサス・インスツルメンツは一切の責任を拒否します。

テキサス・インスツルメンツの製品は、[テキサス・インスツルメンツの販売条件](#)、または [ti.com](https://www.ti.com) やかかる テキサス・インスツルメンツ製品の関連資料などのいずれかを通じて提供する適用可能な条項の下で提供されています。テキサス・インスツルメンツがこれらのリソースを提供することは、適用されるテキサス・インスツルメンツの保証または他の保証の放棄の拡大や変更を意味するものではありません。

お客様がいかなる追加条項または代替条項を提案した場合でも、テキサス・インスツルメンツはそれらに異議を唱え、拒否します。

郵送先住所: Texas Instruments, Post Office Box 655303, Dallas, Texas 75265

Copyright © 2024, Texas Instruments Incorporated

**PACKAGING INFORMATION**

Orderable Device	Status (1)	Package Type	Package Drawing	Pins	Package Qty	Eco Plan (2)	Lead finish/ Ball material (6)	MSL Peak Temp (3)	Op Temp (°C)	Device Marking (4/5)	Samples
TXS0104VQPWRQ1	ACTIVE	TSSOP	PW	14	3000	RoHS & Green	NIPDAU	Level-1-260C-UNLIM	-40 to 125	04VQ1	Samples

(1) The marketing status values are defined as follows:

**ACTIVE:** Product device recommended for new designs.

**LIFEBUY:** TI has announced that the device will be discontinued, and a lifetime-buy period is in effect.

**NRND:** Not recommended for new designs. Device is in production to support existing customers, but TI does not recommend using this part in a new design.

**PREVIEW:** Device has been announced but is not in production. Samples may or may not be available.

**OBSELETE:** TI has discontinued the production of the device.

(2) **RoHS:** TI defines "RoHS" to mean semiconductor products that are compliant with the current EU RoHS requirements for all 10 RoHS substances, including the requirement that RoHS substance do not exceed 0.1% by weight in homogeneous materials. Where designed to be soldered at high temperatures, "RoHS" products are suitable for use in specified lead-free processes. TI may reference these types of products as "Pb-Free".

**RoHS Exempt:** TI defines "RoHS Exempt" to mean products that contain lead but are compliant with EU RoHS pursuant to a specific EU RoHS exemption.

**Green:** TI defines "Green" to mean the content of Chlorine (Cl) and Bromine (Br) based flame retardants meet JS709B low halogen requirements of <=1000ppm threshold. Antimony trioxide based flame retardants must also meet the <=1000ppm threshold requirement.

(3) MSL, Peak Temp. - The Moisture Sensitivity Level rating according to the JEDEC industry standard classifications, and peak solder temperature.

(4) There may be additional marking, which relates to the logo, the lot trace code information, or the environmental category on the device.

(5) Multiple Device Markings will be inside parentheses. Only one Device Marking contained in parentheses and separated by a "~" will appear on a device. If a line is indented then it is a continuation of the previous line and the two combined represent the entire Device Marking for that device.

(6) Lead finish/Ball material - Orderable Devices may have multiple material finish options. Finish options are separated by a vertical ruled line. Lead finish/Ball material values may wrap to two lines if the finish value exceeds the maximum column width.

**Important Information and Disclaimer:**The information provided on this page represents TI's knowledge and belief as of the date that it is provided. TI bases its knowledge and belief on information provided by third parties, and makes no representation or warranty as to the accuracy of such information. Efforts are underway to better integrate information from third parties. TI has taken and continues to take reasonable steps to provide representative and accurate information but may not have conducted destructive testing or chemical analysis on incoming materials and chemicals. TI and TI suppliers consider certain information to be proprietary, and thus CAS numbers and other limited information may not be available for release.

In no event shall TI's liability arising out of such information exceed the total purchase price of the TI part(s) at issue in this document sold by TI to Customer on an annual basis.

**OTHER QUALIFIED VERSIONS OF TXS0104V-Q1 :**

- Catalog : [TXS0104V](#)

NOTE: Qualified Version Definitions:

- Catalog - TI's standard catalog product

PW0014A



**PACKAGE OUTLINE**  
**TSSOP - 1.2 mm max height**

SMALL OUTLINE PACKAGE



NOTES:

1. All linear dimensions are in millimeters. Any dimensions in parenthesis are for reference only. Dimensioning and tolerancing per ASME Y14.5M.
2. This drawing is subject to change without notice.
3. This dimension does not include mold flash, protrusions, or gate burrs. Mold flash, protrusions, or gate burrs shall not exceed 0.15 mm per side.
4. This dimension does not include interlead flash. Interlead flash shall not exceed 0.25 mm per side.
5. Reference JEDEC registration MO-153.

# EXAMPLE BOARD LAYOUT

PW0014A

TSSOP - 1.2 mm max height

SMALL OUTLINE PACKAGE

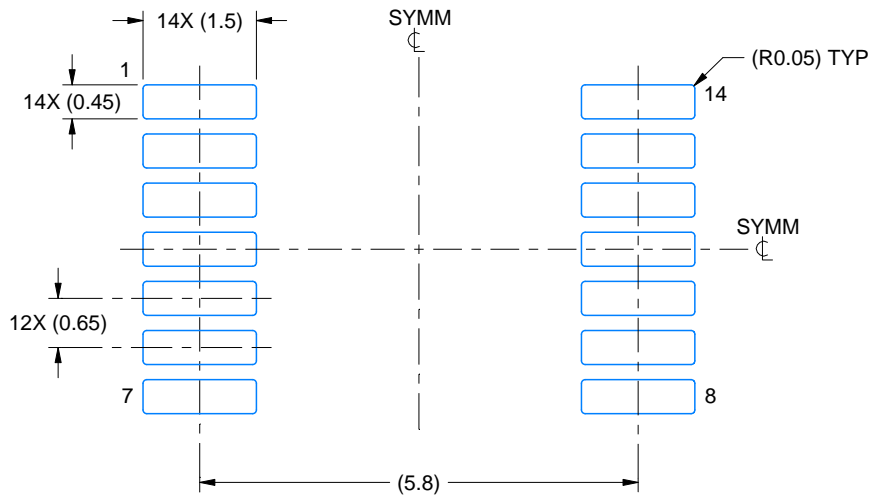

LAND PATTERN EXAMPLE  
EXPOSED METAL SHOWN  
SCALE: 10X

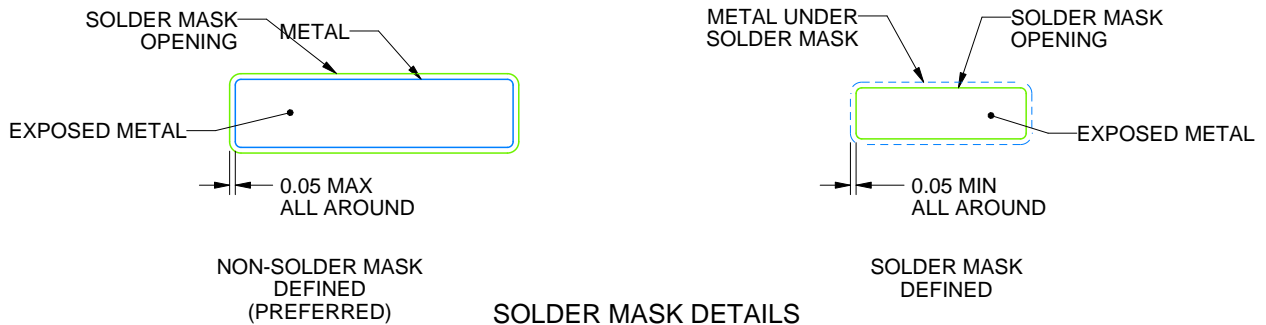

4220202/B 12/2023

NOTES: (continued)

- 6. Publication IPC-7351 may have alternate designs.
- 7. Solder mask tolerances between and around signal pads can vary based on board fabrication site.

# EXAMPLE STENCIL DESIGN

PW0014A

TSSOP - 1.2 mm max height

SMALL OUTLINE PACKAGE



SOLDER PASTE EXAMPLE  
BASED ON 0.125 mm THICK STENCIL  
SCALE: 10X

4220202/B 12/2023

NOTES: (continued)

8. Laser cutting apertures with trapezoidal walls and rounded corners may offer better paste release. IPC-7525 may have alternate design recommendations.
9. Board assembly site may have different recommendations for stencil design.



## 重要なお知らせと免責事項

TI は、技術データと信頼性データ(データシートを含みます)、設計リソース(リファレンス・デザインを含みます)、アプリケーションや設計に関する各種アドバイス、Web ツール、安全性情報、その他のリソースを、欠陥が存在する可能性のある「現状のまま」提供しており、商品性および特定目的に対する適合性の黙示保証、第三者の知的財産権の非侵害保証を含むいかなる保証も、明示的または黙示的にかかわらず拒否します。

これらのリソースは、TI 製品を使用する設計の経験を積んだ開発者への提供を意図したものです。(1) お客様のアプリケーションに適した TI 製品の選定、(2) お客様のアプリケーションの設計、検証、試験、(3) お客様のアプリケーションに該当する各種規格や、その他のあらゆる安全性、セキュリティ、規制、または他の要件への確実な適合に関する責任を、お客様のみが単独で負うものとします。

上記の各種リソースは、予告なく変更される可能性があります。これらのリソースは、リソースで説明されている TI 製品を使用するアプリケーションの開発の目的でのみ、TI はその使用をお客様に許諾します。これらのリソースに関して、他の目的で複製することや掲載することは禁止されています。TI や第三者の知的財産権のライセンスが付与されている訳ではありません。お客様は、これらのリソースを自身で使用した結果発生するあらゆる申し立て、損害、費用、損失、責任について、TI およびその代理人を完全に補償するものとし、TI は一切の責任を拒否します。

TI の製品は、[TI の販売条件](#)、または [ti.com](#) やかかる TI 製品の関連資料などのいずれかを通じて提供する適用可能な条項の下で提供されています。TI がこれらのリソースを提供することは、適用される TI の保証または他の保証の放棄の拡大や変更を意味するものではありません。

お客様がいかなる追加条項または代替条項を提案した場合でも、TI はそれらに異議を唱え、拒否します。

郵送先住所 : Texas Instruments, Post Office Box 655303, Dallas, Texas 75265  
Copyright © 2024, Texas Instruments Incorporated