

TXU0101-Q1 車載用シングル・ビット、固定方向電圧レベル・トランスレータ、シュミット・トリガ入力、3 ステート出力

1 特長

- 完全に構成可能なデュアル・レール設計により、各ポートは 1.1V~5.5V で動作可能
- 3.3V~5.0V で最高 200Mbps をサポート
- シュミット・トリガ入力により低速またはノイズの多い入力に対応
- 入力が静的プルダウン抵抗を内蔵することで、チャンネルがフローティングになることを防止
- 高い駆動強度 (5V で最大 12mA)
- 低消費電力
 - 最大 2.5 μ A (25°C)
 - 最大 6 μ A (-40°C~125°C)
- V_{CC} 絶縁および V_{CC} 切断 (I_{off-float}) 機能
 - どちらかの V_{CC} 入力が 100mV 未満になる、または切り離されると、すべての出力がディセーブルされ高インピーダンス化
- I_{off} により部分的パワーダウン・モードでの動作をサポート
- 制御ロジック (OE) に V_{CC(MIN)} 回路を備えているため、A ポートと B ポートのどちら側からも制御可能
- TXB ファミリのレベル・シフトとピン互換
- 動作温度範囲: -40°C~+125°C
- JESD 78, Class II 準拠で 100mA 超のラッチアップ性能
- JESD 22 を上回る ESD 保護
 - 人体モデルで 2500V
 - 荷電デバイス・モデルで 1500V

2 アプリケーション

- 低速またはノイズの多い入力信号の除去
- インジケータ LED またはブザーの駆動
- メカニカル・スイッチのデバウンス
- 汎用 I/O レベル・シフト
- プッシュプル・レベル・シフト (UART, SPI, JTAG など)

3 概要

TXU0101-Q1 は、1 ビット、2 電源の非反転固定方向電圧レベル変換デバイスです。A ピンは V_{CCA} ロジック・レベルを基準にし、OE ピンは V_{CCA} ロジック・レベルと V_{CBB} ロジック・レベルのいずれかを基準にでき、B ピンは V_{CBB} ロジック・レベルを基準にします。A ポート、B ポートとも 1.1V~5.5V の範囲の入力電圧を受け付けることができます。OE がどちらかの電源を基準として High に設定されているとき、固定方向のデータ伝送が A から B に発生することがあります。OE を Low に設定すると、すべての出力ピンは高インピーダンス状態になります。制御ロジックの動作の概要については、「デバイスの機能モード」を参照してください。

パッケージ情報⁽¹⁾

部品番号	パッケージ	本体サイズ (公称)
TXU0101	SC70 (DCK) (6)	2.00mm × 1.25mm
	SOT-5X3 (DRL) (6) ⁽²⁾	1.60mm × 1.20mm
	SON (DRY) (6)	1.45mm × 1.00mm

- 利用可能なパッケージについては、このデータシートの末尾にある注文情報を参照してください。
- プレビュー版パッケージです。

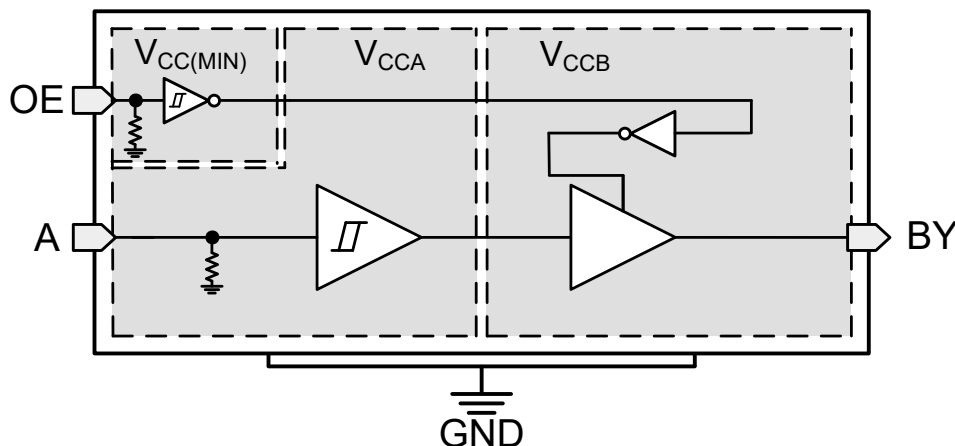

TXU0101-Q1 機能ブロック図



Table of Contents

1 特長	1	8.1 Overview.....	19
2 アプリケーション	1	8.2 Functional Block Diagram.....	19
3 概要	1	8.3 Feature Description.....	20
4 Revision History	2	8.4 Device Functional Modes.....	22
5 Pin Configuration and Functions—TXU0101-Q1	3	9 Application and Implementation	23
6 Specifications	4	9.1 Application Information.....	23
6.1 Absolute Maximum Ratings.....	4	9.2 Typical Application.....	23
6.2 ESD Ratings.....	4	10 Power Supply Recommendations	24
6.3 Recommended Operating Conditions.....	5	11 Layout	25
6.4 Thermal Information.....	5	11.1 Layout Guidelines.....	25
6.5 Electrical Characteristics.....	6	11.2 Layout Example.....	25
6.6 Switching Characteristics, $V_{CCA} = 1.2 \pm 0.1 \text{ V}$	9	12 Device and Documentation Support	26
6.7 Switching Characteristics, $V_{CCA} = 1.5 \pm 0.1 \text{ V}$	10	12.1 Device Support.....	26
6.8 Switching Characteristics, $V_{CCA} = 1.8 \pm 0.15 \text{ V}$	11	12.2 Documentation Support.....	26
6.9 Switching Characteristics, $V_{CCA} = 2.5 \pm 0.2 \text{ V}$	12	12.3 Receiving Notification of Documentation Updates..	26
6.10 Switching Characteristics, $V_{CCA} = 3.3 \pm 0.3 \text{ V}$	13	12.4 サポート・リソース.....	26
6.11 Switching Characteristics, $V_{CCA} = 5.0 \pm 0.5 \text{ V}$	14	12.5 Trademarks.....	26
6.12 Operating Characteristics.....	15	12.6 Electrostatic Discharge Caution.....	26
6.13 Typical Characteristics.....	16	12.7 Glossary.....	26
7 Parameter Measurement Information	17	13 Mechanical, Packaging, and Orderable Information	26
7.1 Load Circuit and Voltage Waveforms.....	17		
8 Detailed Description	19		

4 Revision History

DATE	REVISION	NOTES
August 2022	*	Initial Release

5 Pin Configuration and Functions—TXU0101-Q1



图 5-1. DCK Package, 6-Pin SC70 Transparent (Top View)



图 5-2. DRL Package (Preview), 6-Pin SOT-5X3 Transparent (Top View)

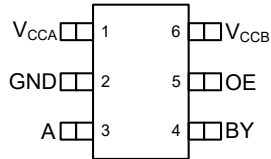

图 5-3. DRY Package, 6-Pin SON Transparent (Top View)

表 5-1. TXU0101 Pin Functions

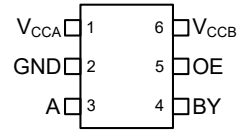
PIN		TYPE ⁽¹⁾	DESCRIPTION
NAME	NO.		
V _{CCA}	1	—	A-port supply voltage. $1.1\text{ V} \leq V_{CCA} \leq 5.5\text{ V}$
GND	2	—	Ground
A	3	I	Input A. Referenced to V _{CCA} .
BY	4	O	Output B. Referenced to V _{CCB} .
OE	5	I	Output Enable. Pull to GND to place all outputs in high-impedance mode. Pull to V _{CCA} or V _{CCB} to enable all outputs.
V _{CCB}	6	—	B-port supply voltage. $1.1\text{ V} \leq V_{CCB} \leq 5.5\text{ V}$

(1) I = input, O = output

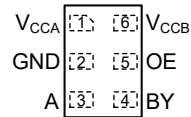
6 Specifications

6.1 Absolute Maximum Ratings

over operating free-air temperature range (unless otherwise noted)⁽¹⁾

			MIN	MAX	UNIT
V _{CCA}	Supply voltage A		-0.5	6.5	V
V _{CCB}	Supply voltage B		-0.5	6.5	V
V _I	Input Voltage ⁽²⁾	I/O Ports (A Port)	-0.5	6.5	V
		I/O Ports (B Port)	-0.5	6.5	
		OE	-0.5	6.5	
V _O	Voltage applied to any output in the high-impedance or power-off state ⁽²⁾	A Port	-0.5	6.5	V
		B Port	-0.5	6.5	
V _O	Voltage applied to any output in the high or low state ^{(2) (3)}	A Port	-0.5	V _{CCA} + 0.5	V
		B Port	-0.5	V _{CCB} + 0.5	
I _{IK}	Input clamp current	V _I < 0	-20		mA
I _{OK}	Output clamp current	V _O < 0	-20		mA
I _O	Continuous output current		-25	25	mA
	Continuous current through V _{CC} or GND		-100	100	
T _j	Junction Temperature			150	°C
T _{stg}	Storage temperature		-65	150	°C

- (1) Operation outside the *Absolute Maximum Ratings* may cause permanent device damage. *Absolute Maximum Ratings* do not imply functional operation of the device at these or any other conditions beyond those listed under *Recommended Operating Conditions*. If used outside the *Recommended Operating Conditions* but within the *Absolute Maximum Ratings*, the device may not be fully functional, and this may affect device reliability, functionality, performance, and shorten the device lifetime.
- (2) The input voltage and output negative-voltage ratings may be exceeded if the input and output current ratings are observed.
- (3) The output positive-voltage rating may be exceeded up to 6.5 V maximum if the output current rating is observed.

6.2 ESD Ratings

			VALUE	UNIT
V _(ESD)	Electrostatic discharge	Human body model (HBM), per AEC Q100-002 ⁽¹⁾	±2500	V
		Charged device model (CDM), per AEC Q100-011	±1500	

- (1) AEC Q100-002 indicates that HBM stressing shall be in accordance with the ANSI/ESDA/JEDEC JS-001 specification.

6.3 Recommended Operating Conditions

over operating free-air temperature range (unless otherwise noted) ⁽¹⁾ ⁽²⁾ ⁽³⁾

		MIN	MAX	UNIT	
V _{CCA}	Supply voltage A	1.08	5.5	V	
V _{CCB}	Supply voltage B	1.08	5.5	V	
I _{OH}	High-level output current	V _{CCO} = 1.1 V	-1.5	mA	
		V _{CCO} = 1.4 V	-3		
		V _{CCO} = 1.65 V	-4.5		
		V _{CCO} = 2.3 V	-8		
		V _{CCO} = 3 V	-10		
		V _{CCO} = 4.5 V	-12		
I _{OL}	Low-level output current	V _{CCO} = 1.1 V	1.5	mA	
		V _{CCO} = 1.4 V	3		
		V _{CCO} = 1.65 V	4.5		
		V _{CCO} = 2.3 V	8		
		V _{CCO} = 3 V	10		
		V _{CCO} = 4.5 V	12		
V _I	Input voltage ⁽³⁾	0	5.5	V	
V _O	Output voltage	Active State	0	V _{CCO}	V
		Tri-State	0	5.5	
T _A	Operating free-air temperature	-40	125	°C	

(1) V_{CCI} is the V_{CC} associated with the input port.

(2) V_{CCO} is the V_{CC} associated with the output port.

(3) All control inputs and data I/Os of this device have weak pulldowns to ensure the line is not floating when undefined external to the device. The input leakage from these weak pulldowns is defined by the I_I specification indicated under [Electrical Characteristics](#).

6.4 Thermal Information

THERMAL METRIC ⁽¹⁾		TXU0101-Q1			UNIT
		DCK (SC70)	DRL (SOT-5X3)	DRY (SON)	
		8 PINS	8 PINS	8 PINS	
R _{θJA}	Junction-to-ambient thermal resistance	215.9	TBD	279.2	°C/W
R _{θJC(top)}	Junction-to-case (top) thermal resistance	143.2	TBD	172.6	°C/W
R _{θJB}	Junction-to-board thermal resistance	76.6	TBD	154.6	°C/W
Y _{JT}	Junction-to-top characterization parameter	58.6	TBD	22.1	°C/W
Y _{JB}	Junction-to-board characterization parameter	76.2	TBD	153.8	°C/W
R _{θJC(bottom)}	Junction-to-case (bottom) thermal resistance	N/A	TBD	N/A	°C/W

(1) For more information about traditional and new thermal metrics, see the [Semiconductor and IC Package Thermal Metrics](#) application report.

6.5 Electrical Characteristics

over operating free-air temperature range (unless otherwise noted)^{(1) (2)}

PARAMETER	TEST CONDITIONS	V _{CCA}	V _{CCB}	Operating free-air temperature (T _A)						UNIT	
				25°C			–40°C to 85°C		–40°C to 125°C		
				MIN	TYP	MAX	MIN	TYP	MAX		MIN
V _{T+}	Positive-going input-threshold voltage	Data Inputs (Ax, Bx) (Referenced to V _{CCI})	1.1 V	1.1 V		0.44	0.88	0.44	0.88	V	
			1.4 V	1.4 V		0.60	0.98	0.60	0.98		
			1.65 V	1.65 V		0.76	1.13	0.76	1.13		
			2.3 V	2.3 V		1.08	1.56	1.08	1.56		
			3 V	3 V		1.48	1.92	1.48	1.92		
			4.5 V	4.5 V		2.19	2.74	2.19	2.74		
			5.5 V	5.5 V		2.65	3.33	2.65	3.33		
		OE (Referenced to V _{CCA} or V _{CCB})	1.1 V	1.1 V		0.44	0.88	0.44	0.88	V	
			1.4 V	1.4 V		0.60	0.98	0.60	0.98		
			1.65 V	1.65 V		0.76	1.13	0.76	1.13		
			2.3 V	2.3 V		1.08	1.56	1.08	1.56		
			3 V	3 V		1.48	1.92	1.48	1.92		
			4.5 V	4.5 V		2.19	2.74	2.19	2.74		
			5.5 V	5.5 V		2.65	3.33	2.65	3.33		
V _{T-}	Negative-going input-threshold voltage	Data Inputs (Ax, Bx) (Referenced to V _{CCI})	1.1 V	1.1 V		0.17	0.48	0.17	0.48	V	
			1.4 V	1.4 V		0.28	0.59	0.28	0.59		
			1.65 V	1.65 V		0.35	0.69	0.35	0.69		
			2.3 V	2.3 V		0.56	0.97	0.56	0.97		
			3 V	3 V		0.89	1.5	0.89	1.5		
			4.5 V	4.5 V		1.51	1.97	1.51	1.97		
			5.5 V	5.5 V		1.88	2.4	1.88	2.4		
		OE (Referenced to V _{CCA} or V _{CCB})	1.1 V	1.1 V		0.17	0.48	0.17	0.48	V	
			1.4 V	1.4 V		0.28	0.59	0.28	0.59		
			1.65 V	1.65 V		0.35	0.69	0.35	0.69		
			2.3 V	2.3 V		0.56	0.97	0.56	0.97		
			3 V	3 V		0.89	1.5	0.89	1.5		
			4.5 V	4.5 V		1.51	1.97	1.51	1.97		
			5.5 V	5.5 V		1.88	2.46	1.88	2.46		
ΔV _T	Input-threshold hysteresis (V _{T+} – V _{T-})	Data Inputs (Ax, Bx) (Referenced to V _{CCI})	1.1 V	1.1 V		0.2	0.4	0.2	0.4	V	
			1.4 V	1.4 V		0.25	0.5	0.25	0.5		
			1.65 V	1.65 V		0.3	0.55	0.3	0.55		
			2.3 V	2.3 V		0.38	0.65	0.38	0.65		
			3 V	3 V		0.46	0.72	0.46	0.72		
			4.5 V	4.5 V		0.58	0.93	0.58	0.93		
			5.5 V	5.5 V		0.69	1.06	0.69	1.06		
		OE (Referenced to V _{CCA} or V _{CCB})	1.1 V	1.1 V		0.15	0.41	0.15	0.41	V	
			1.4 V	1.4 V		0.2	0.5	0.2	0.5		
			1.65 V	1.65 V		0.23	0.55	0.23	0.55		
			2.3 V	2.3 V		0.32	0.65	0.32	0.65		
			3 V	3 V		0.39	0.72	0.39	0.72		
			4.5 V	4.5 V		0.57	0.97	0.57	0.97		
			5.5 V	5.5 V		0.69	1.18	0.69	1.18		

6.5 Electrical Characteristics (continued)

over operating free-air temperature range (unless otherwise noted)^{(1) (2)}

PARAMETER	TEST CONDITIONS	V _{CCA}	V _{CCB}	Operating free-air temperature (T _A)									UNIT
				25°C			–40°C to 85°C			–40°C to 125°C			
				MIN	TYP	MAX	MIN	TYP	MAX	MIN	TYP	MAX	
V _{OH}	High-level output voltage ⁽³⁾	I _{OH} = –0.1 mA	1.1 V – 5.5 V	1.1 V – 5.5 V				V _{CCO} – 0.1			V _{CCO} – 0.1	V	
		I _{OH} = –0.5 mA	1.1 V	1.1 V				0.82			0.82		
		I _{OH} = –3 mA	1.4 V	1.4 V				1			1		
		I _{OH} = –4.5 mA	1.65 V	1.65 V				1.2			1.2		
		I _{OH} = –8 mA	2.3 V	2.3 V				1.7			1.7		
		I _{OH} = –10 mA	3 V	3 V				2.2			2.2		
		I _{OH} = –12 mA	4.5 V	4.5 V				3.7			3.7		
V _{OL}	Low-level output voltage ⁽⁴⁾	I _{OL} = 0.1 mA	1.1 V – 5.5 V	1.1 V – 5.5 V						0.1	0.1	V	
		I _{OL} = 0.5 mA	1.1 V	1.1 V						0.27	0.27		
		I _{OL} = 3 mA	1.4 V	1.4 V						0.35	0.35		
		I _{OL} = 4.5 mA	1.65 V	1.65 V						0.45	0.45		
		I _{OL} = 8 mA	2.3 V	2.3 V						0.7	0.7		
		I _{OL} = 10 mA	3 V	3 V						0.8	0.8		
		I _{OL} = 12 mA	4.5 V	4.5 V						0.8	0.8		
I _I	Input leakage current	OE V _I = V _{CC} or GND	1.1 V – 5.5 V	1.1 V – 5.5 V	–0.1	1.5	–0.1	1.5	–0.1	2	2	μA	
		Data Inputs (A _x , B _x) V _I = V _{CCi} or GND	1.1 V – 5.5 V	1.1 V – 5.5 V	–0.1	1.5	–0.1	1.5	–2	2	2		
I _{off}	Partial power down current	A Port or B Port V _I or V _O = 0 V – 5.5 V	0 V	1.1 V – 5.5 V	–1.5	1.5	–2	2	–2.5	2.5	2.5	μA	
			1.1 V – 5.5 V	0 V	–1.5	1.5	–2	2	–2.5	2.5	2.5		
I _{off-float}	Floating supply Partial power down current	A Port or B Port V _I or V _O = GND	Floating ⁽⁵⁾	1.1 V – 5.5 V	–1.5	1.5	–2	2	–2.5	2.5	2.5	μA	
			0 V – 5.5 V	Floating ⁽⁵⁾	–1.5	1.5	–2	2	–2.5	2.5	2.5		
I _{oz}	Tri-state output current	A or B Port: V _I = V _{CCi} or GND V _O = V _{CCO} or GND OE = GND	1.1 V – 5.5 V	1.1 V – 5.5 V	–0.3	0.3	–1	1	–2	2	2	μA	
I _{CCA}	V _{CCA} supply current	V _I = V _{CCi} or GND I _O = 0	1.1 V – 5.5 V	1.1 V – 5.5 V		1.5		2.5		6	μA		
			0 V	5.5 V	–0.3		–1		–1				
			5.5 V	0 V		1		1.5		3			
	V _I = GND I _O = 0	5.5 V	Floating ⁽⁵⁾		1.5		7		15				
I _{CCB}	V _{CCB} supply current	V _I = V _{CCi} or GND I _O = 0	1.1 V – 5.5 V	1.1 V – 5.5 V		1.5		2.5		6	μA		
			0 V	5.5 V		1		1.5		3			
			5.5 V	0 V	–0.3		–1		–1				
		V _I = GND I _O = 0	Floating ⁽⁵⁾	5.5 V		1.5		7		15			
I _{CCA} + I _{CCB}	Combined supply current	V _I = V _{CCi} or GND I _O = 0	1.1 V – 5.5 V	1.1 V – 5.5 V		2.5		3		6	μA		
C _i	Control Input Capacitance	V _I = 3.3 V or GND	3.3 V	3.3 V		2.75		3		3.5	pF		

6.5 Electrical Characteristics (continued)

over operating free-air temperature range (unless otherwise noted)^{(1) (2)}

PARAMETER		TEST CONDITIONS	V _{CCA}	V _{CCB}	Operating free-air temperature (T _A)									UNIT
					25°C			–40°C to 85°C			–40°C to 125°C			
					MIN	TYP	MAX	MIN	TYP	MAX	MIN	TYP	MAX	
C _{io}	Data I/O Capacitance	OE = GND, V _O = 1.65 V DC +1 MHz –16 dBm sine wave	3.3 V	3.3 V	3			4			4			pF

- (1) V_{CCI} is the V_{CC} associated with the input port.
- (2) V_{CCO} is the V_{CC} associated with the output port.
- (3) Tested at V_I = V_{T+(MAX)}.
- (4) Tested at V_I = V_{T-(MIN)}.
- (5) Floating is defined as a node that is both not actively driven by an external device and has leakage not exceeding 10 nA.

6.6 Switching Characteristics, $V_{CCA} = 1.2 \pm 0.1 \text{ V}$

See [Figure 7-1](#) and [Table 7-1](#) for test circuit and loading. See [Figure 7-2](#), [Figure 7-3](#), and [Figure 7-4](#) for measurement waveforms.

PARAMETER		FROM	TO	Test Conditions	B-Port Supply Voltage (V_{CCB})												UNIT						
					$1.2 \pm 0.1 \text{ V}$			$1.5 \pm 0.1 \text{ V}$			$1.8 \pm 0.15 \text{ V}$			$2.5 \pm 0.2 \text{ V}$				$3.3 \pm 0.3 \text{ V}$			$5.0 \pm 0.5 \text{ V}$		
					MIN	TYP	MAX	MIN	TYP	MAX	MIN	TYP	MAX	MIN	TYP	MAX		MIN	TYP	MAX	MIN	TYP	MAX
t_{pd}	Propagation delay	A	B	-40°C to 85°C	3.3	96	0.5	43	0.5	37	0.5	32	0.5	30	0.5	31	ns						
				-40°C to 125°C	3.3	96	0.5	43	0.5	37	0.5	32	0.5	30	0.5	31							
		B	A	-40°C to 85°C	3.3	95	1.9	80	0.5	75	0.5	70	0.5	69	0.5	69							
				-40°C to 125°C	3.3	95	1.9	80	0.5	75	0.5	70	0.5	69	0.5	69							
t_{dis}	Disable time	OE	A	-40°C to 85°C	28.8	133	28.5	130	28.4	133	28.8	137	28.4	143	18.7	211	ns						
				-40°C to 125°C	28.8	133	28.5	130	28.4	133	28.8	137	28.4	143	18.7	211							
		OE	B	-40°C to 85°C	32.5	150	27.6	117	25.8	110	22.5	104	22.1	112	20.1	181							
				-40°C to 125°C	32.5	150	27.6	117	25.8	110	22.5	104	22.1	112	20.1	181							
t_{en}	Enable time	OE	A	-40°C to 85°C	24.1	237	22.1	229	21.4	230	21.3	232	21.7	235	22.7	244	ns						
				-40°C to 125°C	24.1	237	22.1	229	21.4	230	21.3	232	21.7	235	22.7	244							
		OE	B	-40°C to 85°C	21.3	237	14.3	152	11.2	140	8.8	130	8.2	130	8.4	132							
				-40°C to 125°C	21.3	237	14.3	152	11.2	140	8.8	130	8.2	130	8.4	132							

6.7 Switching Characteristics, $V_{CCA} = 1.5 \pm 0.1 \text{ V}$

See [Figure 7-1](#) and [Table 7-1](#) for test circuit and loading. See [Figure 7-2](#), [Figure 7-3](#), and [Figure 7-4](#) for measurement waveforms.

PARAMETER		FROM	TO	Test Conditions	B-Port Supply Voltage (V_{CCB})												UNIT						
					1.2 ± 0.1 V			1.5 ± 0.1 V			1.8 ± 0.15 V			2.5 ± 0.2 V				3.3 ± 0.3 V			5.0 ± 0.5 V		
					MIN	TYP	MAX	MIN	TYP	MAX	MIN	TYP	MAX	MIN	TYP	MAX		MIN	TYP	MAX	MIN	TYP	MAX
t_{pd}	Propagation delay	A	B	-40°C to 85°C	1.9	80	0.5	31	0.5	25	0.5	19	0.5	17	0.5	15	ns						
				-40°C to 125°C	1.9	80	0.5	31	0.5	25	0.5	20	0.5	18	0.5	16							
		B	A	-40°C to 85°C	0.5	43	0.5	31	0.5	28	0.5	26	0.5	25	0.5	24							
				-40°C to 125°C	0.5	43	0.5	31	0.5	28	0.5	26	0.5	25	0.5	24							
t_{dis}	Disable time	OE	A	-40°C to 85°C	20.0	91	19.0	82	18.8	81	19.2	82	19.6	83	12.2	90	ns						
				-40°C to 125°C	20.0	95	19.0	86	18.8	85	19.2	87	19.6	88	12.2	92							
		OE	B	-40°C to 85°C	27.4	127	21.7	91	19.9	82	16.3	71	15.9	71	13.7	70							
				-40°C to 125°C	27.4	127	21.7	95	19.9	86	16.3	75	15.9	75	13.7	74							
t_{en}	Enable time	OE	A	-40°C to 85°C	14.9	102	14.4	86	13.5	88	12.7	90	12.6	92	13.2	97	ns						
				-40°C to 125°C	14.9	102	14.4	89	13.5	91	12.7	93	12.6	96	13.2	100							
		OE	B	-40°C to 85°C	17.9	175	12.7	80	9.1	69	6.1	57	4.9	53	4.5	54							
				-40°C to 125°C	17.9	175	12.7	81	9.1	71	6.1	60	4.9	56	4.5	57							

6.8 Switching Characteristics, $V_{CCA} = 1.8 \pm 0.15 \text{ V}$

See [Figure 7-1](#) and [Table 7-1](#) for test circuit and loading. See [Figure 7-2](#), [Figure 7-3](#), and [Figure 7-4](#) for measurement waveforms.

PARAMETER		FROM	TO	Test Conditions	B-Port Supply Voltage (V_{CCB})												UNIT						
					$1.2 \pm 0.1 \text{ V}$			$1.5 \pm 0.1 \text{ V}$			$1.8 \pm 0.15 \text{ V}$			$2.5 \pm 0.2 \text{ V}$				$3.3 \pm 0.3 \text{ V}$			$5.0 \pm 0.5 \text{ V}$		
					MIN	TYP	MAX	MIN	TYP	MAX	MIN	TYP	MAX	MIN	TYP	MAX		MIN	TYP	MAX	MIN	TYP	MAX
t_{pd}	Propagation delay	A	B	-40°C to 85°C	0.5	75	0.5	28	0.5	22	0.5	17	0.5	14	0.5	12	ns						
				-40°C to 125°C	0.5	75	0.5	28	0.5	23	0.5	17	0.5	15	0.5	13							
		B	A	-40°C to 85°C	0.5	37	0.5	25	0.5	22	0.5	19	0.5	19	0.5	18							
				-40°C to 125°C	0.5	37	0.5	25	0.5	23	0.5	20	0.5	19	0.5	19							
t_{dis}	Disable time	OE	A	-40°C to 85°C	17.2	79	14.7	67	14.5	65	14.3	65	14.4	66	8.5	71	ns						
				-40°C to 125°C	17.2	83	14.7	71	14.5	69	14.3	70	14.4	71	8.5	75							
		OE	B	-40°C to 85°C	25.4	121	18.7	81	16.5	71	12.8	60	12.5	58	9.8	55							
				-40°C to 125°C	25.4	123	18.7	86	16.5	76	12.8	64	12.5	62	9.8	59							
t_{en}	Enable time	OE	A	-40°C to 85°C	10.9	88	9.5	66	9.4	63	8.6	65	8.2	66	8.1	69	ns						
				-40°C to 125°C	10.9	88	9.5	69	9.4	67	8.6	68	8.2	70	8.1	73							
		OE	B	-40°C to 85°C	16.7	177	10.4	75	8.1	58	4.9	46	3.3	42	2.2	39							
				-40°C to 125°C	16.7	177	10.4	77	8.1	60	4.9	49	3.3	44	2.2	42							

6.9 Switching Characteristics, $V_{CCA} = 2.5 \pm 0.2 \text{ V}$

See [Figure 7-1](#) and [Table 7-1](#) for test circuit and loading. See [Figure 7-2](#), [Figure 7-3](#), and [Figure 7-4](#) for measurement waveforms.

PARAMETER		FROM	TO	Test Conditions	B-Port Supply Voltage (V_{CCB})												UNIT						
					1.2 ± 0.1 V			1.5 ± 0.1 V			1.8 ± 0.15 V			2.5 ± 0.2 V				3.3 ± 0.3 V			5.0 ± 0.5 V		
					MIN	TYP	MAX	MIN	TYP	MAX	MIN	TYP	MAX	MIN	TYP	MAX		MIN	TYP	MAX	MIN	TYP	MAX
t_{pd}	Propagation delay	A	B	-40°C to 85°C	0.5	70	0.5	26	0.5	20	0.5	14	0.5	12	0.5	9	ns						
				-40°C to 125°C	0.5	70	0.5	26	0.5	20	0.5	14	0.5	12	0.5	10							
		B	A	-40°C to 85°C	0.5	32	0.5	19	0.5	17	0.5	14	0.5	13	0.5	13							
				-40°C to 125°C	0.5	32	0.5	20	0.5	17	0.5	14	0.5	13	0.5	13							
t_{dis}	Disable time	OE	A	-40°C to 85°C	12.9	65	10.5	51	9.0	51	8.1	43	8.4	44	5.0	45	ns						
				-40°C to 125°C	12.9	68	10.5	55	9.0	50	8.1	47	8.4	48	5.0	49							
		OE	B	-40°C to 85°C	23.2	112	16.5	74	14.0	61	9.0	46	9.1	44	6.4	39							
				-40°C to 125°C	23.2	115	16.5	79	14.0	66	9.0	51	9.1	48	6.4	43							
t_{en}	Enable time	OE	A	-40°C to 85°C	7.9	80	5.9	50	5.1	44	4.7	39	4.4	40	3.7	41	ns						
				-40°C to 125°C	7.9	80	5.9	53	5.1	47	4.7	42	4.4	43	3.7	44							
		OE	B	-40°C to 85°C	16.3	183	9.2	74	6.0	54	4.0	36	2.1	31	0.5	27							
				-40°C to 125°C	16.3	183	9.2	76	6.0	57	4.0	38	2.1	33	0.5	29							

6.10 Switching Characteristics, $V_{CCA} = 3.3 \pm 0.3 \text{ V}$

See [Figure 7-1](#) and [Table 7-1](#) for test circuit and loading. See [Figure 7-2](#), [Figure 7-3](#), and [Figure 7-4](#) for measurement waveforms.

PARAMETER		FROM	TO	Test Conditions	B-Port Supply Voltage (V_{CCB})												UNIT						
					$1.2 \pm 0.1 \text{ V}$			$1.5 \pm 0.1 \text{ V}$			$1.8 \pm 0.15 \text{ V}$			$2.5 \pm 0.2 \text{ V}$				$3.3 \pm 0.3 \text{ V}$			$5.0 \pm 0.5 \text{ V}$		
					MIN	TYP	MAX	MIN	TYP	MAX	MIN	TYP	MAX	MIN	TYP	MAX		MIN	TYP	MAX	MIN	TYP	MAX
t_{pd}	Propagation delay	A	B	-40°C to 85°C	0.5	69		0.5	25		0.5	19		0.5	13		0.5	11		0.5	8	ns	
				-40°C to 125°C	0.5	69		0.5	25		0.5	19		0.5	13		0.5	11		0.5	9		
		B	A	-40°C to 85°C	0.5	30		0.5	17		0.5	14		0.5	12		0.5	11		0.5	10		
				-40°C to 125°C	0.5	30		0.5	18		0.5	15		0.5	12		0.5	11		0.5	10		
t_{dis}	Disable time	OE	A	-40°C to 85°C	12.9	62		10.1	47		8.7	42		6.9	39		6.6	39		6.9	40	ns	
				-40°C to 125°C	12.9	65		10.1	51		8.7	46		6.9	40		6.6	40		6.9	40		
		OE	B	-40°C to 85°C	22.7	109		15.7	71		13.2	59		8.5	42		7.6	40		4.7	36		
				-40°C to 125°C	22.7	111		15.7	75		13.2	63		8.5	46		7.6	43		4.7	36		
t_{en}	Enable time	OE	A	-40°C to 85°C	6.6	85		4.2	45		3.0	37		2.4	31		2.2	30		1.7	30	ns	
				-40°C to 125°C	6.6	85		4.2	47		3.0	40		2.4	33		2.2	32		1.7	33		
		OE	B	-40°C to 85°C	16.3	192		8.9	76		5.4	55		2.6	34		1.8	27		0.5	22		
				-40°C to 125°C	16.3	192		8.9	78		5.4	57		2.6	36		1.8	29		0.5	24		

6.11 Switching Characteristics, $V_{CCA} = 5.0 \pm 0.5 \text{ V}$

See [Figure 7-1](#) and [Table 7-1](#) for test circuit and loading. See [Figure 7-2](#), [Figure 7-3](#), and [Figure 7-4](#) for measurement waveforms.

PARAMETER		FROM	TO	Test Conditions	B-Port Supply Voltage (V_{CCB})												UNIT						
					$1.2 \pm 0.1 \text{ V}$			$1.5 \pm 0.1 \text{ V}$			$1.8 \pm 0.15 \text{ V}$			$2.5 \pm 0.2 \text{ V}$				$3.3 \pm 0.3 \text{ V}$			$5.0 \pm 0.5 \text{ V}$		
					MIN	TYP	MAX	MIN	TYP	MAX	MIN	TYP	MAX	MIN	TYP	MAX		MIN	TYP	MAX	MIN	TYP	MAX
t_{pd}	Propagation delay	A	B	-40°C to 85°C	0.5	69		0.5	24		0.5	18		0.5	13		0.5	10		0.5	8	ns	
				-40°C to 125°C	0.5	69		0.5	24		0.5	19		0.5	13		0.5	11		0.5	8		
		B	A	-40°C to 85°C	0.5	31		0.5	15		0.5	12		0.5	9		0.5	8		0.5	8		
				-40°C to 125°C	0.5	31		0.5	16		0.5	13		0.5	10		0.5	9		0.5	8		
t_{dis}	Disable time	OE	A	-40°C to 85°C	10.8	60		7.7	42		5.9	38		4.2	31		3.4	31		2.8	30	ns	
				-40°C to 125°C	10.8	62		7.7	46		5.9	40		4.2	33		3.4	33		2.8	32		
		OE	B	-40°C to 85°C	9.7	109		5.9	69		13.2	56		8.4	40		6.9	37		3.7	30		
				-40°C to 125°C	9.7	111		5.9	73		13.2	60		8.4	43		6.9	39		3.7	33		
t_{en}	Enable time	OE	A	-40°C to 85°C	6.0	102		2.8	44		1.2	33		0.5	25		0.5	22		0.5	21	ns	
				-40°C to 125°C	6.0	102		2.8	46		1.2	36		0.5	27		0.5	24		0.5	23		
		OE	B	-40°C to 85°C	16.7	212		8.8	82		4.8	58		1.6	35		0.5	26		0.5	19		
				-40°C to 125°C	16.7	212		8.8	83		4.8	60		1.6	37		0.5	28		0.5	21		

6.12 Operating Characteristics

$T_A = 25^\circ\text{C}$ (1)

PARAMETER		Test Conditions	Supply Voltage ($V_{CCB} = V_{CCA}$)						UNIT
			1.2 ± 0.1 V	1.5 ± 0.1 V	1.8 ± 0.15 V	2.5 ± 0.2 V	3.3 ± 0.3 V	5.0 ± 0.5 V	
			TYP	TYP	TYP	TYP	TYP	TYP	
C_{pdA} (2)	A to B: outputs enabled	A Port CL = 0, RL = Open f = 10 MHz $t_{rise} = t_{fall} = 1$ ns	2	2	2	2	2	3	pF
	A to B: outputs disabled		2	2	2	2	2	3	
	B to A: outputs enabled		12	12	12	13	13	16	
	B to A: outputs disabled		2	2	2	2	2	3	
C_{pdB} (3)	A to B: outputs enabled	B Port CL = 0, RL = Open f = 10 MHz $t_{rise} = t_{fall} = 1$ ns	12	12	12	13	13	16	pF
	A to B: outputs disabled		2	2	2	2	2	3	
	B to A: outputs enabled		2	2	2	2	2	3	
	B to A: outputs disabled		2	2	2	2	2	3	

- (1) See the [CMOS Power Consumption and \$C_{pd}\$ Calculation](#) application report for additional information about how power dissipation capacitance affects power consumption.
- (2) A-Port power dissipation capacitance per transceiver.
- (3) B-Port power dissipation capacitance per transceiver.

6.13 Typical Characteristics

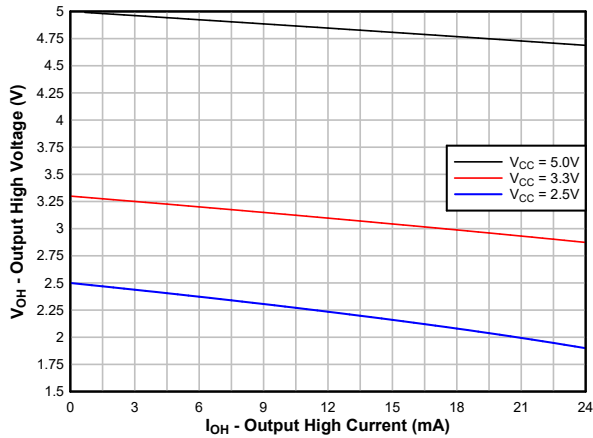

6-1. Typical ($T_A=25^\circ C$) Output High Voltage (V_{OH}) vs Source Current (I_{OH})

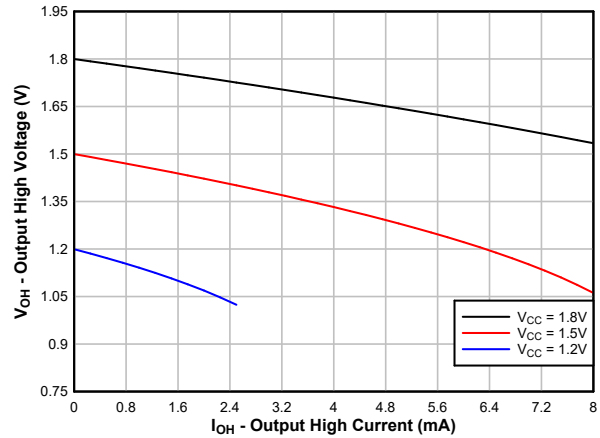

6-2. Typical ($T_A=25^\circ C$) Output High Voltage (V_{OH}) vs Source Current (I_{OH})

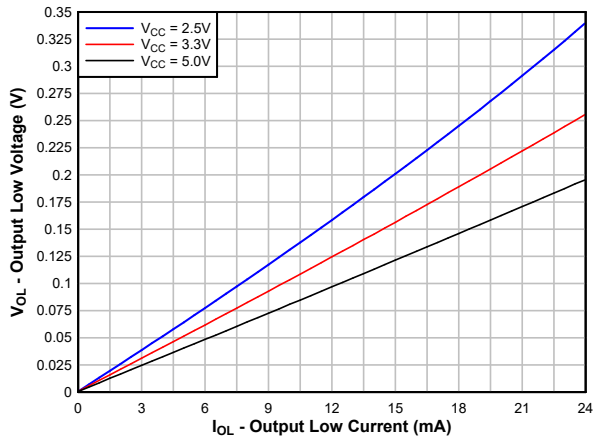

6-3. Typical ($T_A=25^\circ C$) Output Low Voltage (V_{OL}) vs Sink Current (I_{OL})

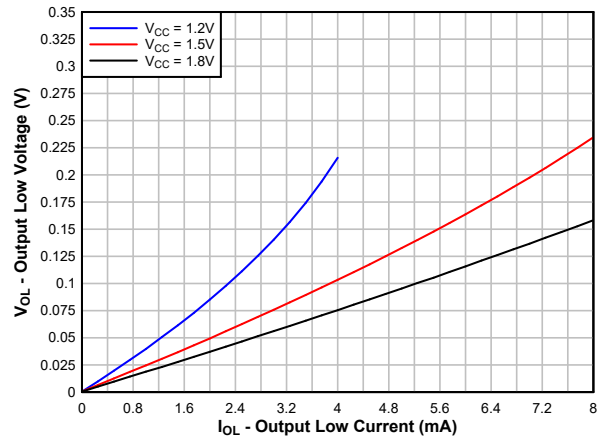

6-4. Typical ($T_A=25^\circ C$) Output Low Voltage (V_{OL}) vs Sink Current (I_{OL})

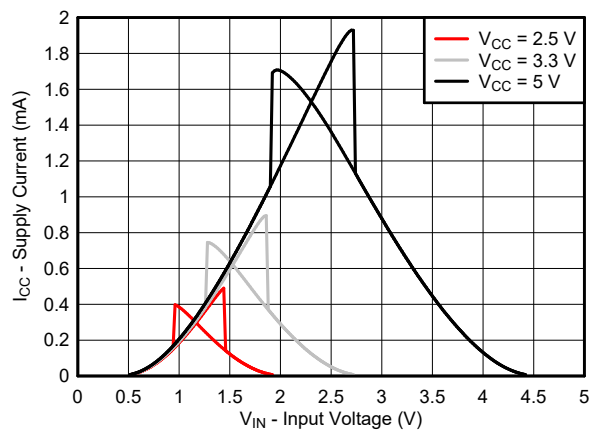

6-5. Typical ($T_A=25^\circ C$) Supply Current (I_{CC}) vs Input Voltage (V_{IN})

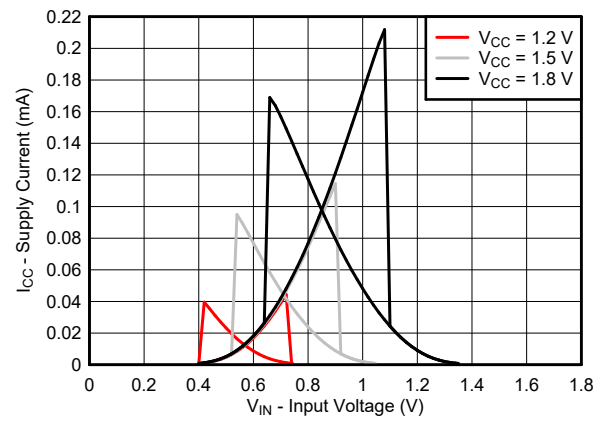

6-6. Typical ($T_A=25^\circ C$) Supply Current (I_{CC}) vs Input Voltage (V_{IN})

7 Parameter Measurement Information

7.1 Load Circuit and Voltage Waveforms

Unless otherwise noted, generators supply all input pulses that have the following characteristics:

- $f = 1 \text{ MHz}$
- $Z_O = 50 \Omega$
- $\Delta t/\Delta V \leq 1 \text{ ns/V}$

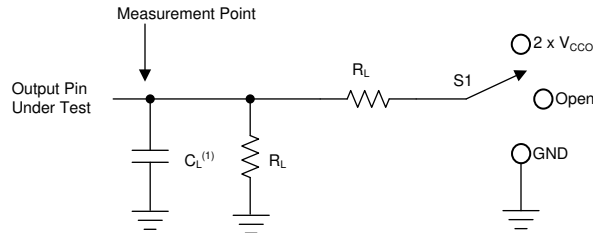

1. C_L includes probe and jig capacitance.

图 7-1. Load Circuit

表 7-1. Load Circuit Conditions

Parameter	V_{CCO}	R_L	C_L	S_1	V_{TP}
t_{pd} Propagation (delay) time	1.1 V – 5.5 V	10 k Ω	5 pF	Open	N/A
t_{en}, t_{dis} Enable time, disable time	1.1 V – 1.6 V	10 k Ω	5 pF	$2 \times V_{CCO}$	0.1 V
	1.65 V – 2.7 V	10 k Ω	5 pF	$2 \times V_{CCO}$	0.15 V
	3.0 V – 5.5 V	10 k Ω	5 pF	$2 \times V_{CCO}$	0.3 V
t_{en}, t_{dis} Enable time, disable time	1.1 V – 1.6 V	10 k Ω	5 pF	GND	0.1 V
	1.65 V – 2.7 V	10 k Ω	5 pF	GND	0.15 V
	3.0 V – 5.5 V	10 k Ω	5 pF	GND	0.3 V

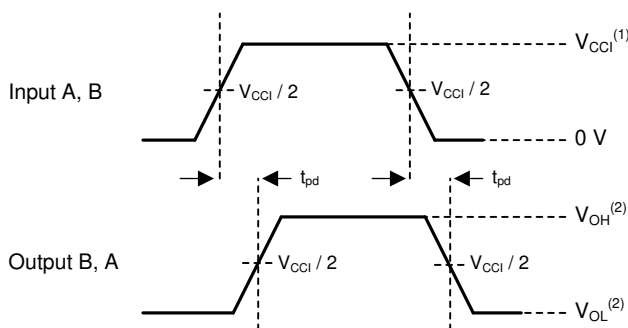

1. V_{CCI} is the supply pin associated with the input port.
2. V_{OH} and V_{OL} are typical output voltage levels that occur with specified R_L , C_L , and S_1

图 7-2. Propagation Delay

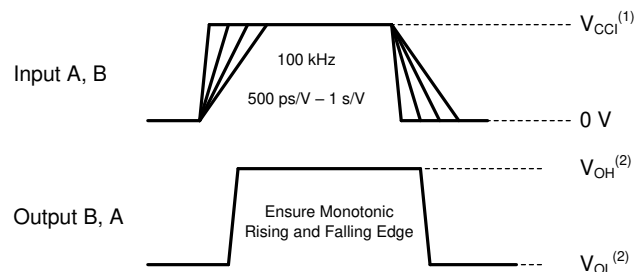

1. V_{CCI} is the supply pin associated with the input port.
2. V_{OH} and V_{OL} are typical output voltage levels that occur with specified R_L , C_L , and S_1

图 7-3. Input Transition Rise and Fall Rate

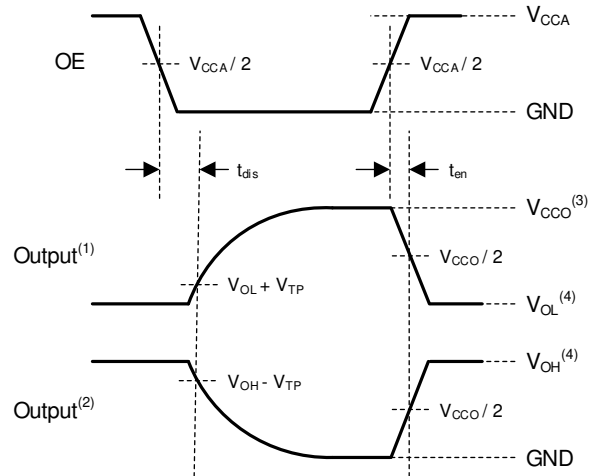

1. Output waveform on the condition that input is driven to a valid Logic Low.
2. Output waveform on the condition that input is driven to a valid Logic High.
3. V_{CCO} is the supply pin associated with the output port.
4. V_{OH} and V_{OL} are typical output voltage levels with specified R_L , C_L , and S_1 .

7-4. Enable Time And Disable Time

8 Detailed Description

8.1 Overview

The TXU0101-Q1 is a 4-bit translating transceiver that uses two individually configurable power-supply rails. The device is operational with V_{CCA} and V_{CCB} supplies as low as 1.1 V and as high as 5.5 V. Additionally, the device can be operated with $V_{CCA} = V_{CCB}$. The A port is designed to track V_{CCA} , and the B port is designed to track V_{CCB} .

The TXU0101-Q1 device is designed for asynchronous communication between data buses, and transmits data with fixed direction from the A bus to the B bus on some channels and from the B bus to the A bus on the remaining channels. The output-enable input (OE) is used to disable the outputs so the buses are effectively isolated. The output-enable pin of the TXU0101-Q1 (OE) can be referenced to either V_{CCA} or V_{CCB} . The OE pin can be left floating or externally pulled down to ground to ensure the high-impedance state of the level shifter outputs during power up or power down.

This device is fully specified for partial-power-down applications using the I_{off} current. The I_{off} protection circuitry ensures that no excessive current is drawn from or sourced into an input or output while the device is powered down.

The VCC isolation or VCC disconnect feature ensures that if either VCC is less than 100 mV or disconnected with the complementary supply within recommended operating conditions, then the outputs disable and are set to the high-impedance state while the supply current is maintained. The $I_{off-float}$ circuitry ensures that no excessive current is drawn from or sourced into an input or output while the supply is floating.

Glitch-free power supply sequencing allows either supply rail to be powered on or off in any order while providing robust power sequencing performance.

8.2 Functional Block Diagram

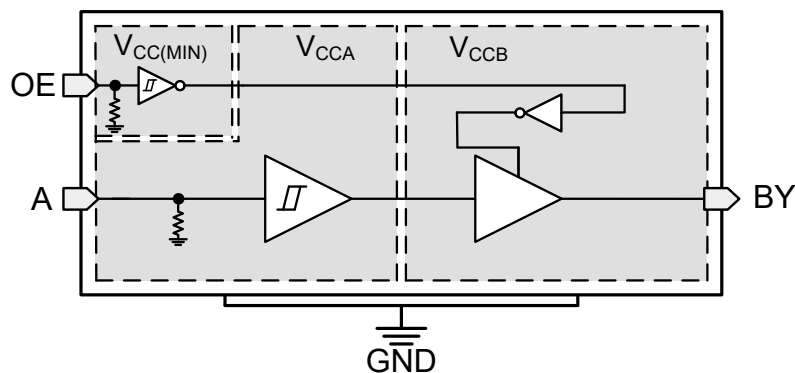

8.3 Feature Description

8.3.1 CMOS Schmitt-Trigger Inputs with Integrated Pulldowns

Standard CMOS inputs are high impedance and are typically modeled as a resistor in parallel with the input capacitance given in the [Electrical Characteristics](#). The worst case resistance is calculated with the maximum input voltage, given in the [Absolute Maximum Ratings](#), and the maximum input leakage current, given in the [Electrical Characteristics](#), using ohm's law ($R = V \div I$).

The Schmitt-trigger input architecture provides hysteresis as defined by ΔV_T in the [Electrical Characteristics](#), which makes this device extremely tolerant to slow or noisy inputs. Driving the inputs slowly will increase dynamic current consumption of the device. See [Understanding Schmitt Triggers](#) for additional information regarding Schmitt-trigger inputs.

8.3.1.1 Inputs with Integrated Static Pull-Down Resistors

This device has 5 M Ω typical integrated weak pull-downs for each input. This feature allows all inputs to be left floating without the concern for unstable outputs or increased current consumption. This also helps to reduce external component count for applications where not all channels are used or need to be fixed low. If an external pull-up is required, it should be no larger than 1 M Ω to avoid contention with the 5 M Ω internal pull-down.

8.3.2 Control Logic (OE) with $V_{CC(MIN)}$ Circuitry

The output-enable input (OE) is used to disable the outputs so the buses are effectively isolated. The output-enable pin of the TXU0x04 has $V_{CC(MIN)}$ circuitry, which allows the OE pin to operate with the lower supply voltage. The [Over-Voltage Tolerant Inputs](#) feature allows the OE pin to operate with the higher supply voltage. This combination means that the enable pin can be referenced to either V_{CCA} or V_{CCB} supply. Multiple permutations of each device are possible since the controller can be placed on either the A or B port and can still control the enable pin.

8.3.3 Balanced High-Drive CMOS Push-Pull Outputs

A balanced output allows the device to sink and source similar currents. The high drive capability of this device creates fast edges into light loads, so routing and load conditions should be considered to prevent ringing. Additionally, the outputs of this device are capable of driving larger currents than the device can sustain without being damaged. The electrical and thermal limits that must be followed at all times are defined in [Absolute Maximum Ratings](#).

8.3.4 VCC Isolation and V_{CC} Disconnect

The outputs for this device disable and enter a high-impedance state when either supply is <100 mV or left floating (disconnected), with the complementary supply within the recommended operating conditions. It is recommended to keep the inputs low before floating (disconnecting) either supply.

The $I_{CCx(floating)}$ in the [Electrical Characteristics](#) specifies the maximum supply current. The $I_{off(float)}$ in the [Electrical Characteristics](#) specifies the maximum leakage into or out of any input or output pin on the device.

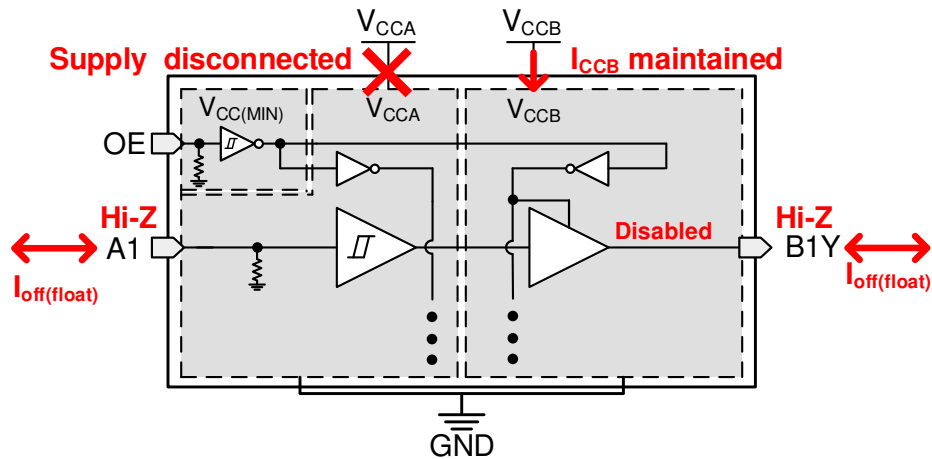

8-1. V_{CC} Disconnect Feature

8.3.5 Over-Voltage Tolerant Inputs

Input signals to this device can be driven above the supply voltage as long as they remain below the maximum input voltage value specified in the [Recommended Operating Conditions](#).

8.3.6 Glitch-Free Power Supply Sequencing

Either supply rail may be powered on or off in any order without producing a glitch on the inputs or outputs (that is, where the output erroneously transitions to V_{CC} when it should be held low or vice versa). Glitches of this nature can be misinterpreted by a peripheral as a valid data bit, which could trigger a false device reset of the peripheral, a false device configuration of the peripheral, or even a false data initialization by the peripheral.

8.3.7 Negative Clamping Diodes

Figure 8-2 shows the inputs and outputs to this device that have negative clamping diodes.

注意

Voltages beyond the values specified in the [Absolute Maximum Ratings](#) table can cause damage to the device. The input negative-voltage and output voltage ratings may be exceeded if the input and output clamp-current ratings are observed.

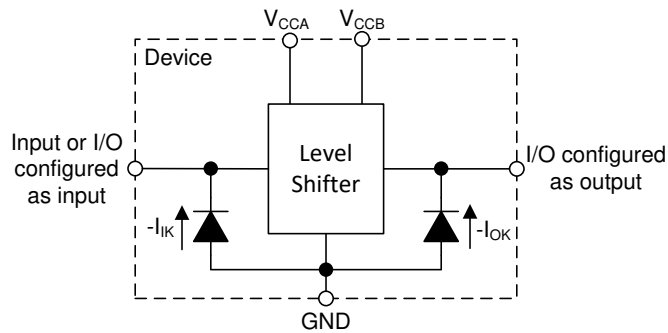

Figure 8-2. Electrical Placement of Clamping Diodes for Each Input and Output

8.3.8 Fully Configurable Dual-Rail Design

The V_{CCA} and V_{CCB} pins can be supplied at any voltage from 1.1 V to 5.5 V, making the device suitable for translating between any of the voltage nodes (1.2 V, 1.5 V, 1.8 V, 3.3 V, and 5.0 V).

8.3.9 Supports High-Speed Translation

The TXU0101-Q1 device can support high data-rate applications. The translated signal data rate can be up to 200 Mbps when the signal is translated from 3.3 V to 5.0 V.

8.4 Device Functional Modes

Table 8-1. Function Table

CONTROL INPUTS	Port Status		OPERATION
	Input	Output	
H	L	L	Unidirectional non-inverting voltage translation
H	H	H	Unidirectional non-inverting voltage translation
L	X	Hi-Z	Isolation

9 Application and Implementation

注

Information in the following applications sections is not part of the TI component specification, and TI does not warrant its accuracy or completeness. TI's customers are responsible for determining suitability of components for their purposes, as well as validating and testing their design implementation to confirm system functionality.

9.1 Application Information

The TXU0101-Q1 device can be used in level-translation applications for interfacing devices or systems operating at different interface voltages with one another. The TXU0101-Q1 device is ideal for use in applications where a push-pull driver is connected to the data inputs. The maximum data rate can be up to 200 Mbps when the device translates a signal from 3.3 V to 5.0 V.

9.2 Typical Application



图 9-1. TXU0101-Q1 LDO Reset Application

9.2.1 Design Requirements

Use the parameters listed in 表 9-1 for this design example.

表 9-1. Design Parameters

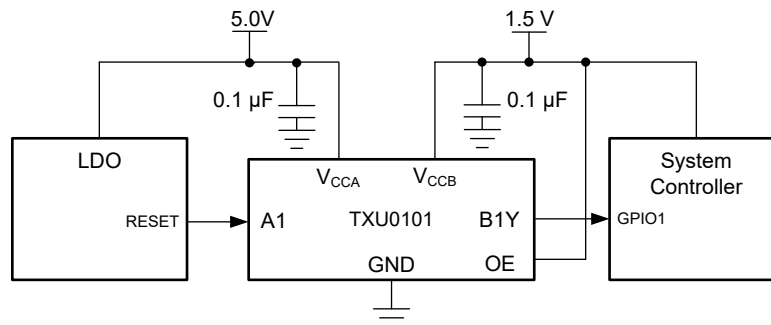
DESIGN PARAMETERS	EXAMPLE VALUES
Input voltage range	1.1 V to 5.5 V
Output voltage range	1.1 V to 5.5 V

9.2.2 Detailed Design Procedure

To begin the design process, determine the following:

- Input voltage range
 - Use the supply voltage of the device that is driving the TXU0101-Q1 device to determine the input voltage range. For a valid logic-high, the value must exceed the positive-going input-threshold voltage (V_{T+}) of the input port. For a valid logic low the value must be less than the negative-going input-threshold voltage (V_{T-}) of the input port.
- Output voltage range
 - Use the supply voltage of the device that the TXU0101-Q1 device is driving to determine the output voltage range.

9.2.3 Application Curve

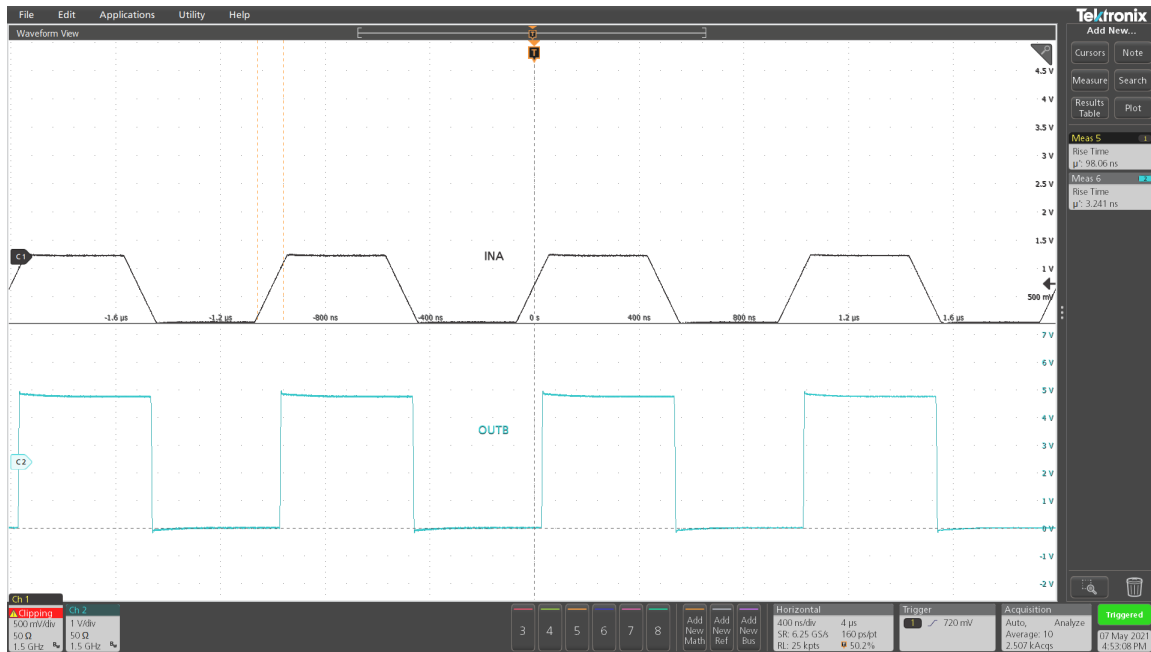

Figure 9-2. Up Translation at 1 MHz (1.2 V to 5 V)

10 Power Supply Recommendations

Always apply a ground reference to the GND pins first. This device is designed for glitch free power sequencing without any supply sequencing requirements such as ramp order or ramp rate.

[Glitch-Free Power Supply Sequencing](#) describes how this device was designed with various power supply sequencing methods in mind to help prevent unintended triggering of downstream devices.

11 Layout

11.1 Layout Guidelines

To ensure reliability of the device, following common printed-circuit board layout guidelines is recommended:

- Use bypass capacitors on the power supply pins and place them as close to the device as possible. A 0.1 μF capacitor is recommended, but transient performance can be improved by having 1 μF and 0.1 μF capacitors in parallel as bypass capacitors.
- The high drive capability of this device creates fast edges into light loads so routing and load conditions should be considered to prevent ringing.

11.2 Layout Example

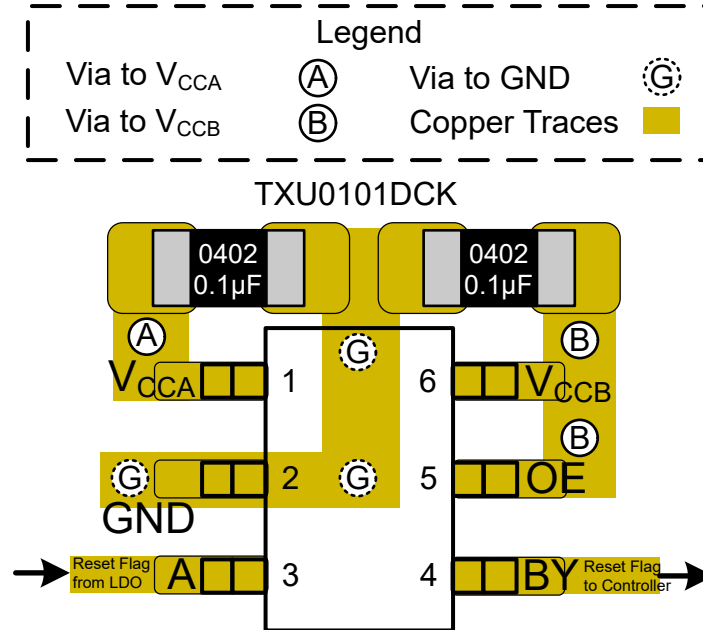

☒ 11-1. Layout Example – TXU0101-Q1

12 Device and Documentation Support

12.1 Device Support

12.1.1 Regulatory Requirements

No statutory or regulatory requirements apply to this device.

There are no special characteristics for this product.

12.2 Documentation Support

12.2.1 Related Documentation

- Texas Instruments, [Understanding Schmitt Triggers application report](#)
- Texas Instruments, [CMOS Power Consumption and \$C_{pd}\$ Calculation application report](#)

12.3 Receiving Notification of Documentation Updates

To receive notification of documentation updates, navigate to the device product folder on [ti.com](#). Click on [Subscribe to updates](#) to register and receive a weekly digest of any product information that has changed. For change details, review the revision history included in any revised document.

12.4 サポート・リソース

TI E2E™ サポート・フォーラムは、エンジニアが検証済みの回答と設計に関するヒントをエキスパートから迅速かつ直接得ることができる場所です。既存の回答を検索したり、独自の質問をしたりすることで、設計に必要な支援を迅速に得ることができます。

リンクされているコンテンツは、該当する貢献者により、現状のまま提供されるものです。これらは TI の仕様を構成するものではなく、必ずしも TI の見解を反映したものではありません。TI の[使用条件](#)を参照してください。

12.5 Trademarks

TI E2E™ is a trademark of Texas Instruments.

すべての商標は、それぞれの所有者に帰属します。

12.6 Electrostatic Discharge Caution



This integrated circuit can be damaged by ESD. Texas Instruments recommends that all integrated circuits be handled with appropriate precautions. Failure to observe proper handling and installation procedures can cause damage.

ESD damage can range from subtle performance degradation to complete device failure. Precision integrated circuits may be more susceptible to damage because very small parametric changes could cause the device not to meet its published specifications.

12.7 Glossary

[TI Glossary](#) This glossary lists and explains terms, acronyms, and definitions.

13 Mechanical, Packaging, and Orderable Information

The following pages include mechanical, packaging, and orderable information. This information is the most current data available for the designated devices. This data is subject to change without notice and revision of this document. For browser-based versions of this data sheet, refer to the left-hand navigation.

PACKAGING INFORMATION

Orderable Device	Status (1)	Package Type	Package Drawing	Pins	Package Qty	Eco Plan (2)	Lead finish/ Ball material (6)	MSL Peak Temp (3)	Op Temp (°C)	Device Marking (4/5)	Samples
TXU0101QDCKRQ1	ACTIVE	SC70	DCK	6	3000	RoHS & Green	NIPDAU	Level-1-260C-UNLIM	-40 to 125	1LR	Samples
TXU0101QDRYRQ1	ACTIVE	SON	DRY	6	5000	RoHS & Green	NIPDAU	Level-1-260C-UNLIM	-40 to 125	MQ	Samples

(1) The marketing status values are defined as follows:

ACTIVE: Product device recommended for new designs.

LIFEBUY: TI has announced that the device will be discontinued, and a lifetime-buy period is in effect.

NRND: Not recommended for new designs. Device is in production to support existing customers, but TI does not recommend using this part in a new design.

PREVIEW: Device has been announced but is not in production. Samples may or may not be available.

OBSOLETE: TI has discontinued the production of the device.

(2) **RoHS:** TI defines "RoHS" to mean semiconductor products that are compliant with the current EU RoHS requirements for all 10 RoHS substances, including the requirement that RoHS substance do not exceed 0.1% by weight in homogeneous materials. Where designed to be soldered at high temperatures, "RoHS" products are suitable for use in specified lead-free processes. TI may reference these types of products as "Pb-Free".

RoHS Exempt: TI defines "RoHS Exempt" to mean products that contain lead but are compliant with EU RoHS pursuant to a specific EU RoHS exemption.

Green: TI defines "Green" to mean the content of Chlorine (Cl) and Bromine (Br) based flame retardants meet JS709B low halogen requirements of <=1000ppm threshold. Antimony trioxide based flame retardants must also meet the <=1000ppm threshold requirement.

(3) MSL, Peak Temp. - The Moisture Sensitivity Level rating according to the JEDEC industry standard classifications, and peak solder temperature.

(4) There may be additional marking, which relates to the logo, the lot trace code information, or the environmental category on the device.

(5) Multiple Device Markings will be inside parentheses. Only one Device Marking contained in parentheses and separated by a "~" will appear on a device. If a line is indented then it is a continuation of the previous line and the two combined represent the entire Device Marking for that device.

(6) Lead finish/Ball material - Orderable Devices may have multiple material finish options. Finish options are separated by a vertical ruled line. Lead finish/Ball material values may wrap to two lines if the finish value exceeds the maximum column width.

Important Information and Disclaimer:The information provided on this page represents TI's knowledge and belief as of the date that it is provided. TI bases its knowledge and belief on information provided by third parties, and makes no representation or warranty as to the accuracy of such information. Efforts are underway to better integrate information from third parties. TI has taken and continues to take reasonable steps to provide representative and accurate information but may not have conducted destructive testing or chemical analysis on incoming materials and chemicals. TI and TI suppliers consider certain information to be proprietary, and thus CAS numbers and other limited information may not be available for release.

In no event shall TI's liability arising out of such information exceed the total purchase price of the TI part(s) at issue in this document sold by TI to Customer on an annual basis.

OTHER QUALIFIED VERSIONS OF TXU0101-Q1 :

- Catalog : [TXU0101](#)

NOTE: Qualified Version Definitions:

- Catalog - TI's standard catalog product

DCK0006A



PACKAGE OUTLINE

SOT - 1.1 max height

SMALL OUTLINE TRANSISTOR

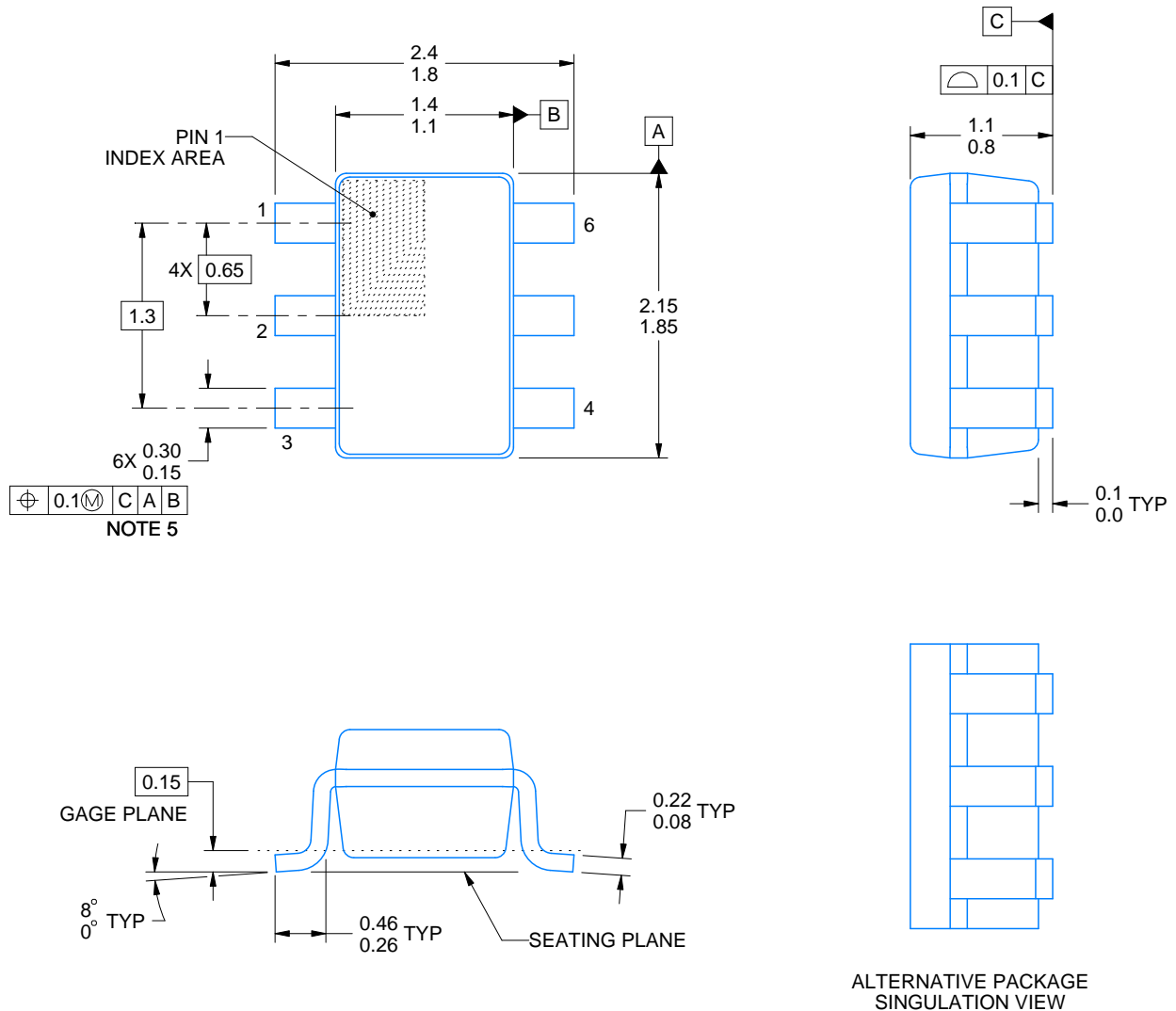

4214835/B 04/2024

NOTES:

1. All linear dimensions are in millimeters. Any dimensions in parenthesis are for reference only. Dimensioning and tolerancing per ASME Y14.5M.
2. This drawing is subject to change without notice.
3. Body dimensions do not include mold flash or protrusion. Mold flash and protrusion shall not exceed 0.15 per side.
4. Falls within JEDEC MO-203 variation AB.

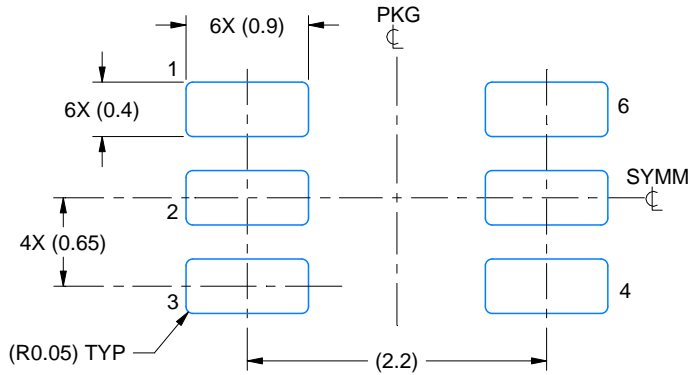

LAND PATTERN EXAMPLE
EXPOSED METAL SHOWN
SCALE:18X

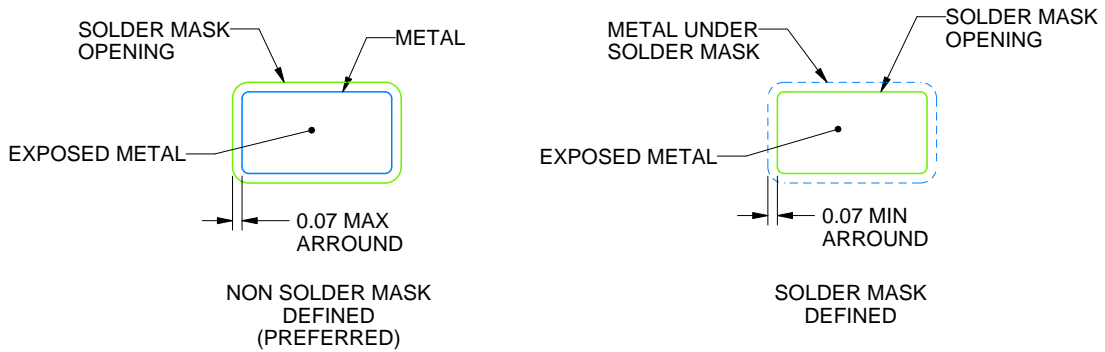

SOLDER MASK DETAILS

4214835/B 04/2024

NOTES: (continued)

- 5. Publication IPC-7351 may have alternate designs.
- 6. Solder mask tolerances between and around signal pads can vary based on board fabrication site.

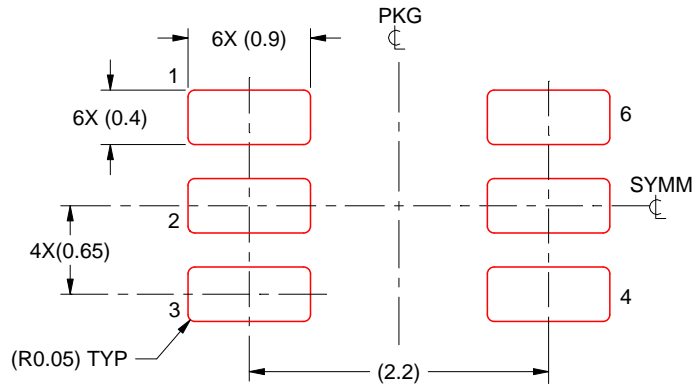

SOLDER PASTE EXAMPLE
BASED ON 0.125 THICK STENCIL
SCALE:18X

4214835/B 04/2024

NOTES: (continued)

7. Laser cutting apertures with trapezoidal walls and rounded corners may offer better paste release. IPC-7525 may have alternate design recommendations.
8. Board assembly site may have different recommendations for stencil design.

GENERIC PACKAGE VIEW

DRY 6

USON - 0.6 mm max height

PLASTIC SMALL OUTLINE - NO LEAD



Images above are just a representation of the package family, actual package may vary.
Refer to the product data sheet for package details.

4207181/G

DRY0006B

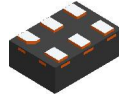

PACKAGE OUTLINE

USON - 0.55 mm max height

PLASTIC SMALL OUTLINE - NO LEAD

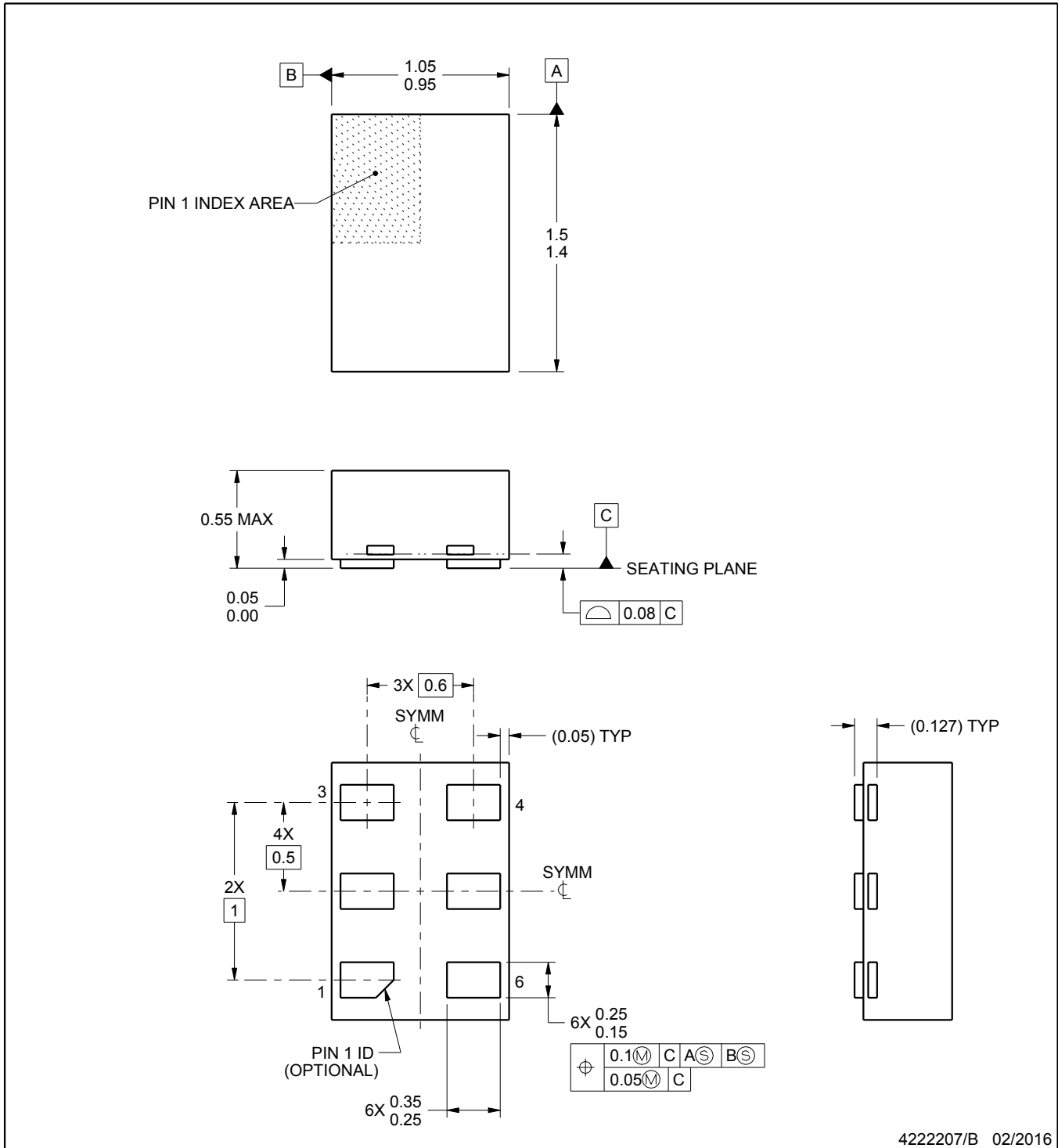

4222207/B 02/2016

NOTES:

1. All linear dimensions are in millimeters. Any dimensions in parenthesis are for reference only. Dimensioning and tolerancing per ASME Y14.5M.
2. This drawing is subject to change without notice.

EXAMPLE BOARD LAYOUT

DRY0006B

USON - 0.55 mm max height

PLASTIC SMALL OUTLINE - NO LEAD



LAND PATTERN EXAMPLE
1:1 RATIO WITH PKG SOLDER PADS
SCALE:40X

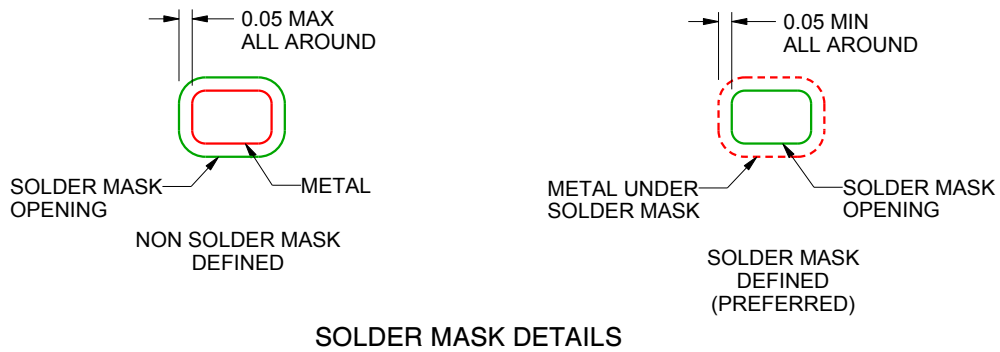

SOLDER MASK DETAILS

4222207/B 02/2016

NOTES: (continued)

3. For more information, see QFN/SON PCB application report in literature No. SLUA271 (www.ti.com/lit/slue271).

EXAMPLE STENCIL DESIGN

DRY0006B

USON - 0.55 mm max height

PLASTIC SMALL OUTLINE - NO LEAD



SOLDER PASTE EXAMPLE
BASED ON 0.075 - 0.1 mm THICK STENCIL
SCALE:40X

4222207/B 02/2016

NOTES: (continued)

4. Laser cutting apertures with trapezoidal walls and rounded corners may offer better paste release. IPC-7525 may have alternate design recommendations.

重要なお知らせと免責事項

TI は、技術データと信頼性データ（データシートを含みます）、設計リソース（リファレンス・デザインを含みます）、アプリケーションや設計に関する各種アドバイス、Web ツール、安全性情報、その他のリソースを、欠陥が存在する可能性のある「現状のまま」提供しており、商品性および特定目的に対する適合性の黙示保証、第三者の知的財産権の非侵害保証を含むいかなる保証も、明示的または黙示的にかかわらず拒否します。

これらのリソースは、TI 製品を使用する設計の経験を積んだ開発者への提供を意図したものです。(1) お客様のアプリケーションに適した TI 製品の選定、(2) お客様のアプリケーションの設計、検証、試験、(3) お客様のアプリケーションに該当する各種規格や、その他のあらゆる安全性、セキュリティ、規制、または他の要件への確実な適合に関する責任を、お客様のみが単独で負うものとし、

上記の各種リソースは、予告なく変更される可能性があります。これらのリソースは、リソースで説明されている TI 製品を使用するアプリケーションの開発の目的でのみ、TI はその使用をお客様に許諾します。これらのリソースに関して、他の目的で複製することや掲載することは禁止されています。TI や第三者の知的財産権のライセンスが付与されている訳ではありません。お客様は、これらのリソースを自身で使用した結果発生するあらゆる申し立て、損害、費用、損失、責任について、TI およびその代理人を完全に補償するものとし、TI は一切の責任を拒否します。

TI の製品は、[TI の販売条件](#)、または [ti.com](#) やかかる TI 製品の関連資料などのいずれかを通じて提供する適用可能な条項の下で提供されています。TI がこれらのリソースを提供することは、適用される TI の保証または他の保証の放棄の拡大や変更を意味するものではありません。

お客様がいかなる追加条項または代替条項を提案した場合でも、TI はそれらに異議を唱え、拒否します。

郵送先住所：Texas Instruments, Post Office Box 655303, Dallas, Texas 75265
Copyright © 2024, Texas Instruments Incorporated