

UCC27524 デュアル 5A、高速ローサイド ゲート ドライバ、負入力電圧機能付

1 特長

- 業界標準のピン配置
- 2つの独立したゲート駆動チャンネル
- ソースおよびシンク駆動ピーク電流: 5A
- 出力ごとに独立したイネーブル機能
- TTL および CMOS 互換のロジック スレッショルド (電源電圧に無関係)
- ヒステリシス付きのロジック スレッショルドによる高いノイズ耐性
- 負入力電圧 (-5V) に対応
- 入力およびイネーブルピンの電圧レベルが VDD ピンのバイアス電源電圧に制限されない
- 4.5V~18V の単一電源電圧範囲
- VDD UVLO 時に出力を Low に保持 (パワーアップ / パワーダウン時のグリッチを防止)
- 高速伝搬遅延時間: 17ns (標準値)
- 高速立ち上がり / 立ち下がり時間: 6ns/10ns (標準値)
- 2チャンネル間遅延マッチング: 1ns (代表値)
- 2出力の並列による高駆動電流
- 入力フローティング時に出力を Low に保持
- SOIC-8、HVSSOP-8 PowerPAD™ パッケージ オプション
- 動作時の接合部温度範囲: -40~150°C

2 アプリケーション

- スイッチ モード電源
- DC/DC コンバータ
- モータ制御、太陽光発電
- 最新の広バンドギャップ パワー デバイス (GaN など) 用ゲート駆動

3 概要

UCC27524 デバイスは、デュアル チャンネルで高速な、ローサイドのゲートドライバ デバイスで、MOSFET および IGBT 電源スイッチを効果的に駆動できます。UCC27524 には、入力ピンで -5V を直接扱う機能があるため、堅牢性が向上しています。UCC27524 はデュアル非反転ドライバです。本質的に貫通電流を最小限に抑える設計により、UCC27524 は、容量性負荷に対してソース / シンクともに最大 5A の高いピーク電流パルスを供給できます。また、レール ツー レールの駆動能力を持ち、伝搬遅延は標準 17ns と非常に小さくなっています。さらに、2つのチャンネル間で内部伝搬遅延がマッチングされるため、同期整流器などタイミング条件の厳しいデュアル ゲートドライバを必要とするアプリケーションに最適です。また、2つのチャンネルを並列接続して実質的な電流駆動能力を高めることも、1つの入力信号で2つのスイッチを並行して駆動することも可能です。入力ピンのスレッショルドは、TTL および CMOS 互換の低電圧ロジックに基づき、VDD 電源電圧に依存しない固定値となっています。上限と下限のスレッショルド間に幅広いヒステリシスが設けられているため、優れたノイズ耐性が得られます。

製品情報

部品番号	パッケージ (1)	本体サイズ (公称)
UCC27524	D (SOIC 8)	4.90mm × 3.91mm
	DGN (HVSSOP 8)	3.00mm × 3.00mm
	DSD (WSON 8)	

(1) 供給されているすべてのパッケージについては、[セクション 13](#) を参照してください。

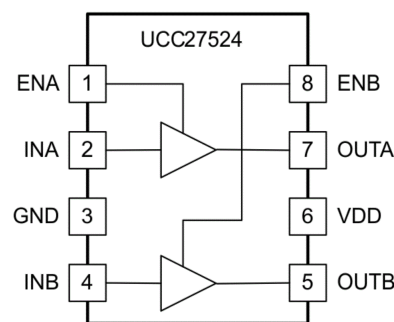

デュアル非反転入力



Table of Contents

1 特長	1	8 Application and Implementation	20
2 アプリケーション	1	8.1 Application Information.....	20
3 概要	1	8.2 Typical Application.....	20
4 概要 (続き)	3	9 Power Supply Recommendations	25
5 Pin Configuration and Functions	4	10 Layout	26
6 Specifications	5	10.1 Layout Guidelines.....	26
6.1 Absolute Maximum Ratings.....	5	10.2 Layout Example.....	27
6.2 ESD Ratings.....	5	10.3 Thermal Considerations.....	27
6.3 Recommended Operating Conditions.....	5	11 Device and Documentation Support	28
6.4 Thermal Information.....	6	11.1 Device Support.....	28
6.5 Electrical Characteristics.....	6	11.2 ドキュメントの更新通知を受け取る方法.....	28
6.6 Switching Characteristics.....	8	11.3 サポート・リソース.....	28
6.7 Timing Diagrams.....	9	11.4 Trademarks.....	28
6.8 Typical Characteristics.....	10	11.5 静電気放電に関する注意事項.....	28
7 Detailed Description	14	11.6 用語集.....	28
7.1 Overview.....	14	12 Revision History	28
7.2 Functional Block Diagram.....	15	13 Mechanical, Packaging, and Orderable Information	29
7.3 Feature Description.....	15		
7.4 Device Functional Modes.....	18		

4 概要 (続き)

安全な動作のために、UCC27524 の入力ピンに内部プルアップおよびプルダウン抵抗により、入力ピンがフローティング状態のときには出力が **Low** に保持されます。UCC27524 は、イネーブルピン (**ENA** および **ENB**) を搭載し、ドライバアプリケーションの動作をよりきめ細かく制御できます。これらのピンは、アクティブ ハイ ロジックでは内部で **VDD** にプルアップされ、標準動作時にはオープンになります。

UCC27524 ファミリー デバイスは、**SOIC-8 (D)**、露出したパッド (**DGN**) パッケージ付きの **VSSOP-8**、および露出したパッド (**DSD**) パッケージ付きの **3mm × 3mm WSON-8** パッケージで供給されます。

5 Pin Configuration and Functions



図 5-1. D and DGN Packages 8-Pin SOIC and HVSSOP Top View



図 5-2. DSD Package 8-Pin WSON Top View

表 5-1. Pin Functions

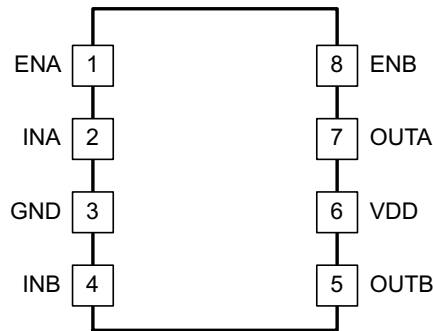
PIN		I/O	DESCRIPTION
NAME	NO.		
ENA	1	I	Enable input for Channel A: ENA is biased LOW to disable the Channel A output regardless of the INA state. ENA is biased HIGH or left floating to enable the Channel A output. ENA is allowed to float; hence the pin-to-pin compatibility with the UCC27324 N/C pin.
ENB	8	I	Enable input for Channel B: ENB is biased LOW to disables the Channel B output regardless of the INB state. ENB is biased HIGH or left floating to enable Channel B output. ENB is allowed to float hence; the pin-to-pin compatibility with the UCC27324 N/C pin.
GND	3	-	Ground: All signals are referenced to this pin.
INA	2	I	Input to Channel A: INA is the non-inverting input in the UCC27524 device. OUTA is held LOW if INA is unbiased or floating.
INB	4	I	Input to Channel B: INB is the non-inverting input in the UCC27524 device. OUTB is held LOW if INB is unbiased or floating.
OUTA	7	O	Output of Channel A
OUTB	5	O	Output of Channel B
VDD	6	I	Bias supply input

6 Specifications

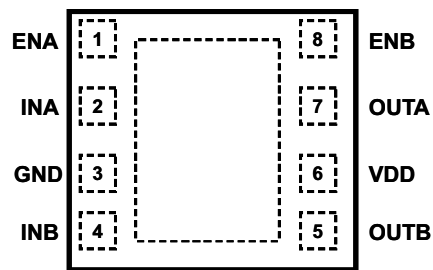
6.1 Absolute Maximum Ratings

over operating free-air temperature range (unless otherwise noted)^{(1) (2)}

		MIN	MAX	UNIT
Supply voltage	VDD	-0.3	20	V
OUTA, OUTB voltage	DC	-0.3	VDD + 0.3	V
	Repetitive pulse < 200 ns ⁽⁴⁾	-2	VDD + 0.3	V
Output continuous source/sink current	I _{OUT_DC}		0.3	A
Output pulsed source/sink current (0.5 μs)	I _{OUT_pulsed}		5	A
INA, INB, ENA, ENB voltage ⁽³⁾	D and DGN package	-5	20	V
	DSD package	-0.3	20	V
Operating virtual junction temperature, T _J		-40	150	°C
Storage temperature, T _{stg}		-65	150	°C

- (1) Stresses beyond those listed under *Absolute Maximum Ratings* may cause permanent damage to the device. These are stress ratings only, which do not imply functional operation of the device at these or any other conditions beyond those indicated under *Recommended Operating Conditions*. Exposure to absolute-maximum-rated conditions for extended periods may affect device reliability.
- (2) All voltages are with respect to GND unless otherwise noted. Currents are positive into, negative out of the specified terminal. See Packaging Section of the datasheet for thermal limitations and considerations of packages.
- (3) The maximum voltage on the Input and Enable pins is not restricted by the voltage on the VDD pin.
- (4) Values are verified by characterization on bench.

6.2 ESD Ratings

		VALUE	UNIT	
V _(ESD)	Electrostatic discharge	Human-body model (HBM), per ANSI/ESDA/ JEDEC JS-001 ⁽¹⁾	V	
		D, DGN Package		±2000
		DSD package		±4000
		Charged-device model (CDM), per JEDEC specification JESD22-C101 ⁽²⁾	±1000	

- (1) JEDEC document JEP155 states that 500-V HBM allows safe manufacturing with a standard ESD control process.
- (2) JEDEC document JEP157 states that 250-V CDM allows safe manufacturing with a standard ESD control process.

6.3 Recommended Operating Conditions

over operating free-air temperature range (unless otherwise noted)

		MIN	NOM	MAX	UNIT
Supply voltage, VDD		4.5	12	18	V
Operating junction temperature		-40		140	°C
Input voltage, INA, INB	D and DGN package	-2		18	V
Input voltage, INA, INB	DSD package	0		18	
Enable voltage, ENA and ENB		-2		18	V

6.4 Thermal Information

THERMAL METRIC ⁽¹⁾		UCC27524			Unit
		DGN	D	DSD	
		8 PINS	8 PINS	8 PINS	
R _{θJA}	Junction-to-ambient thermal resistance	48.9	126.4	46.7	°C/W
R _{θJC(top)}	Junction-to-case (top) thermal resistance	71.8	67.0	46.7	
R _{θJB}	Junction-to-board thermal resistance	22.3	69.9	22.4	
Ψ _{JT}	Junction-to-top characterization parameter	2.6	19.2	0.7	
Ψ _{JB}	Junction-to-board characterization parameter	22.3	69.1	22.6	
R _{θJC(bot)}	Junction-to-case (bottom) thermal resistance	4.5	n/a	9.5	

(1) For more information about traditional and new thermal metrics, see the *Semiconductor and IC Package Thermal Metrics* application report, [SPRA953](#).

6.5 Electrical Characteristics

Unless otherwise noted, V_{DD} = 12 V, T_A = T_J = -40°C to 150°C, 1-μF capacitor from V_{DD} to GND, no load on the output. Typical condition specifications are at 25°C.

PARAMETER		TEST CONDITIONS	MIN	TYP	MAX	UNIT
BIAS CURRENTS (D, DGN)						
I _{VDDq}	VDD quiescent supply current	V _{INx} = 3.3 V, V _{DD} = 3.4 V, ENx = VDD		300	450	μA
I _{VDD}	VDD static supply current	V _{INx} = 3.3 V, ENx = VDD		0.6	1.0	mA
I _{VDD}	VDD static supply current	V _{INx} = 0 V, ENx = VDD		0.7	1.0	mA
I _{VDDO}	VDD operating current	f _{SW} = 1000 kHz, ENx = VDD, V _{INx} = 0 V – 3.3 V PWM		3.2	3.8	mA
I _{DIS}	VDD disable current	V _{INx} = 3.3 V, ENx = 0 V		0.8	1.1	mA
BIAS CURRENTS (DSD)						
I _{DD(off)}	Start-up current	V _{DD} = 3.4 V, INA = V _{DD} , INB = V _{DD}	55	110	175	μA
		V _{DD} = 3.4 V, INA = GND, INB = GND	25	75	145	
UNDERVOLTAGE LOCKOUT (UVLO) (D, DGN)						
V _{VDD_ON}	VDD UVLO rising threshold		3.8	4.1	4.4	V
V _{VDD_OFF}	VDD UVLO falling threshold		3.5	3.8	4.1	V
V _{VDD_HYS}	VDD UVLO hysteresis			0.3		V
UNDERVOLTAGE LOCKOUT (UVLO) (DSD)						
V _{ON}	Supply start threshold	T _J = 25°C	3.91	4.2	4.5	V
		T _J = -40°C to 140°C	3.7	4.2	4.65	
V _{OFF}	Minimum operating voltage after supply start		3.4	3.9	4.4	
V _{DD_H}	Supply voltage hysteresis		0.2	0.3	0.5	
INPUT (INA, INB) (D, DGN)						
V _{INx_H}	Input signal high threshold	Output High, ENx = HIGH	1.8	2	2.3	V
V _{INx_L}	Input signal low threshold	Output Low, ENx = HIGH	0.8	1	1.2	V
V _{INx_HYS}	Input signal hysteresis			1		V
R _{INx}	INx pin pulldown resistor	INx = 3.3 V		120		kΩ
INPUT (INA, INB) (DSD)						

6.5 Electrical Characteristics (続き)

Unless otherwise noted, VDD = 12 V, TA = TJ = –40°C to 150°C, 1-μF capacitor from VDD to GND, no load on the output. Typical condition specifications are at 25°C.

PARAMETER		TEST CONDITIONS	MIN	TYP	MAX	UNIT
V _{IN_H}	Input signal high threshold	Output high for non-inverting input pins Output low for inverting input pins	1.9	2.1	2.3	V
V _{IN_L}	Input signal low threshold	Output low for non-inverting input pins Output high for inverting input pins	1	1.2	1.4	
V _{IN_HYS}	Input hysteresis		0.7	0.9	1.1	
ENABLE (ENA, ENB) (D, DGN)						
V _{ENx_H}	Enable signal high threshold	Output High, INx = HIGH	1.8	2	2.3	V
V _{ENx_L}	Enable signal low threshold	Output Low, INx = HIGH	0.8	1	1.2	V
V _{ENx_HYS}	Enable signal hysteresis			1		V
R _{ENx}	EN pin pullup resistance	ENx = 0 V		200		kΩ
ENABLE (ENA, ENB) (DSD)						
V _{EN_H}	Enable signal high threshold	Output enabled	1.9	2.1	2.3	V
V _{EN_L}	Enable signal low threshold	Output disabled	0.95	1.15	1.35	
V _{EN_HYS}	Enable hysteresis		0.7	0.95	1.1	
OUTPUTS (OUTA, OUTB) (D, DGN)						
I _{SRC} ⁽¹⁾	Peak output source current	VDD = 12 V, C _{VDD} = 10 μF, C _L = 0.1 μF, f = 1 kHz		5		A
I _{SNK} ⁽¹⁾	Peak output sink current	VDD = 12 V, C _{VDD} = 10 μF, C _L = 0.1 μF, f = 1 kHz		–5		A
R _{OH} ⁽²⁾	Pullup resistance	I _{OUT} = –50 mA, See セクション 7.3.4 .		5	8.5	Ω
R _{OL}	Pulldown resistance	I _{OUT} = 50 mA		0.6	1.1	Ω
OUTPUTS (OUTA, OUTB) (DSD)						
I _{SNK/SRC} ⁽¹⁾	Sink/source peak current	C _{LOAD} = 0.22 μF, F _{SW} = 1 kHz		±5		A
V _{DD} -V _{OH}	High output voltage	I _{OUT} = –10 mA			0.075	V
V _{OL}	Low output voltage	I _{OUT} = 10 mA			0.01	
R _{OH} ⁽²⁾	Output pullup resistance	I _{OUT} = –10 mA	2.5	5	7.5	Ω
R _{OL}	Output pulldown resistance	I _{OUT} = 10 mA	0.15	0.5	1	Ω

(1) Parameter not tested in production.

(2) Output pullup resistance in this table is a DC measurement that measures resistance of PMOS structure only (not N-channel structure).

6.6 Switching Characteristics

Unless otherwise noted, $V_{DD} = V_{EN} = 12\text{ V}$, $T_A = T_J = -40^\circ\text{C}$ to 150°C , 1- μF capacitor from VDD to GND, no load on the output. Typical condition specifications are at 25°C (1).

PARAMETER		TEST CONDITIONS	MIN	TYP	MAX	UNIT	
D, DGN package							
t_{Rx}	Rise time	$C_{LOAD} = 1.8\text{ nF}$, 20% to 80%, $V_{in} = 0\text{ V} - 3.3\text{ V}$		6	10	ns	
t_{Fx}	Fall time	$C_{LOAD} = 1.8\text{ nF}$, 90% to 10%, $V_{in} = 0\text{ V} - 3.3\text{ V}$		10	14	ns	
t_{D1x}	Turn-on propagation delay	$C_{LOAD} = 1.8\text{ nF}$, V_{INx_H} of the input rise to 10% of output rise, $V_{in} = 0\text{ V} - 3.3\text{ V}$, $F_{sw} = 500\text{ kHz}$, 50% duty cycle, $T_J = 125^\circ\text{C}$		17	27	ns	
t_{D2x}	Turn-off propagation delay	$C_{LOAD} = 1.8\text{ nF}$, V_{INx_L} of the input fall to 90% of output fall, $V_{in} = 0\text{ V} - 3.3\text{ V}$, $F_{sw} = 500\text{ kHz}$, 50% duty cycle, $T_J = 125^\circ\text{C}$		17	27	ns	
t_{D3x}	Enable propagation delay	$C_{LOAD} = 1.8\text{ nF}$, V_{ENx_H} of the enable rise to 10% of output rise, $V_{in} = 0\text{ V} - 3.3\text{ V}$, $F_{sw} = 500\text{ kHz}$, 50% duty cycle, $T_J = 125^\circ\text{C}$		17	27	ns	
t_{D4x}	Disable propagation delay	$C_{LOAD} = 1.8\text{ nF}$, V_{ENx_L} of the enable fall to 90% of output fall, $V_{in} = 0\text{ V} - 3.3\text{ V}$, $F_{sw} = 500\text{ kHz}$, 50% duty cycle, $T_J = 125^\circ\text{C}$		17	27	ns	
t_M	Delay matching between two channels	$C_{LOAD} = 1.8\text{ nF}$, $V_{in} = 0\text{ V} - 3.3\text{ V}$, $F_{sw} = 500\text{ kHz}$, 50% duty cycle, $INA = INB$, $ t_{RA} - t_{RB} $, $ t_{FA} - t_{FB} $		1	2	ns	
t_{PWmin}	Minimum input pulse width	$C_L = 1.8\text{ nF}$, $V_{in} = 0\text{ V} - 3.3\text{ V}$, $F_{sw} = 500\text{ kHz}$, $V_o > 1.5\text{ V}$		10	15	ns	
DSD package							
t_R	Rise time	$C_{LOAD} = 1.8\text{ nF}$		7	18	ns	
t_F	Fall time	$C_{LOAD} = 1.8\text{ nF}$		6	10	ns	
t_M	Delay matching between 2 channels	$INA = INB$, $OUTA$ and $OUTB$ at 50% transition point		1	4	ns	
t_{PW}	Minimum input pulse width that changes the output state			15	25	ns	
t_{D1} , t_{D2}	Input to output propagation delay	$C_{LOAD} = 1.8\text{ nF}$, 5-V input pulse		6	13	23	ns
t_{D3} , t_{D4}	EN to output propagation delay	$C_{LOAD} = 1.8\text{ nF}$, 5-V enable pulse		6	13	23	ns

(1) Switching parameters are not tested in production.

6.7 Timing Diagrams

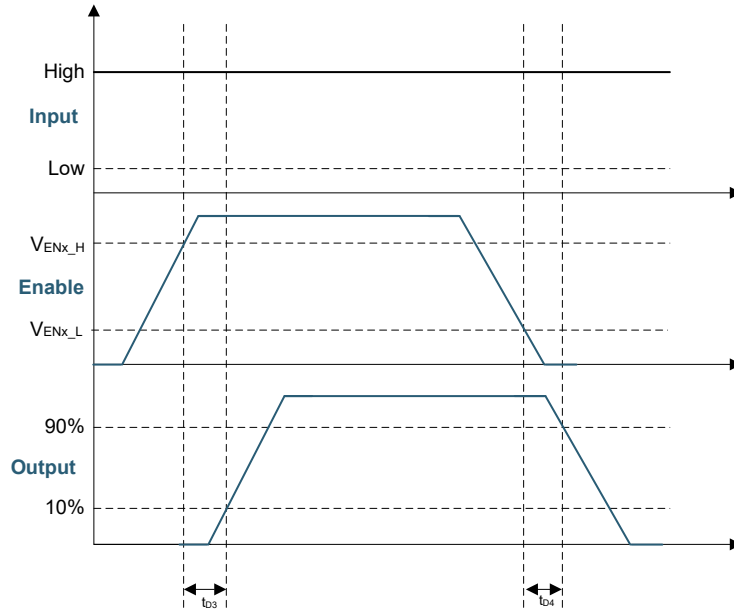

☒ 6-1. Enable Function

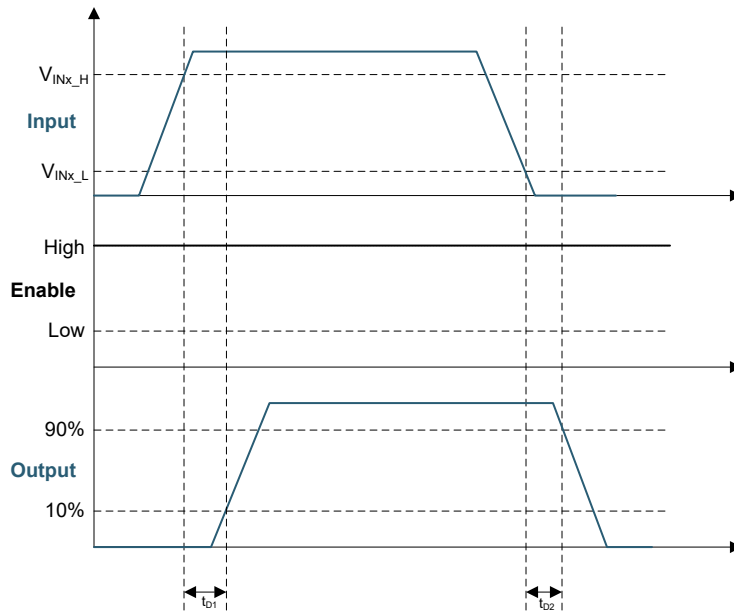

☒ 6-2. Input-Output Operation

6.8 Typical Characteristics

Unless otherwise specified, VDD=12 V, INx=3.3 V, ENx=3.3 V, T_J = 25°C, no load



图 6-3. Start-Up and Quiescent Current



图 6-4. Operating Supply Current (Both Outputs Switching)

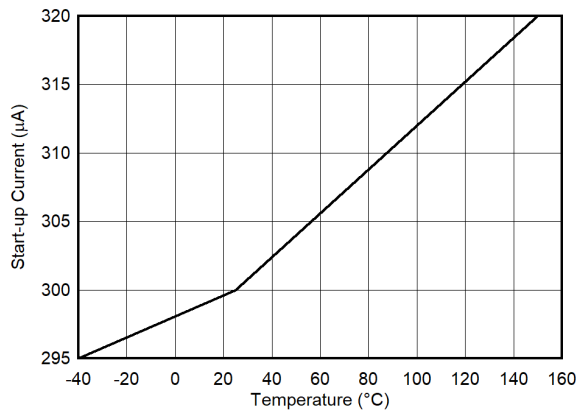

图 6-5. Static Supply Current (Outputs in DC On or Off Condition)

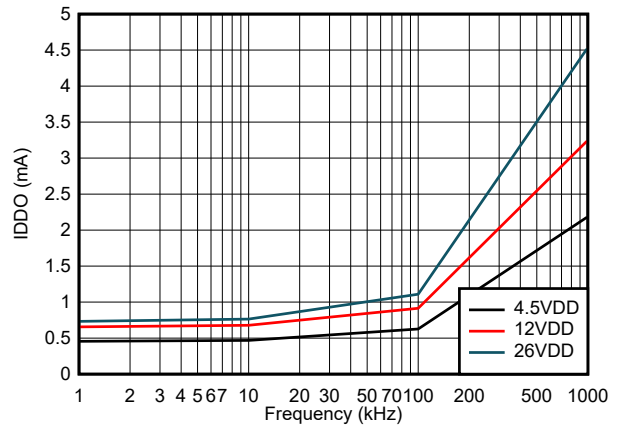

图 6-6. Disable Current (EN = 0 V)

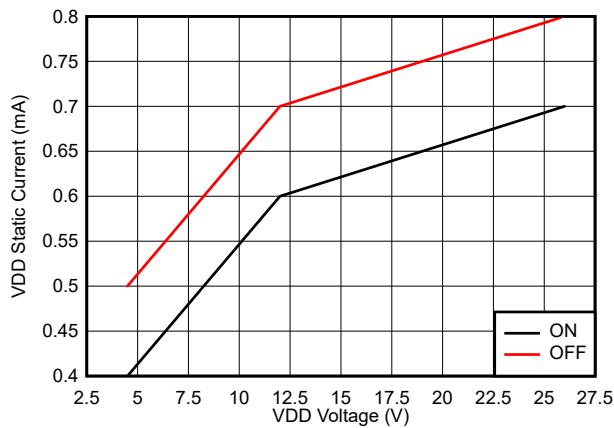

图 6-7. VDD UVLO Threshold

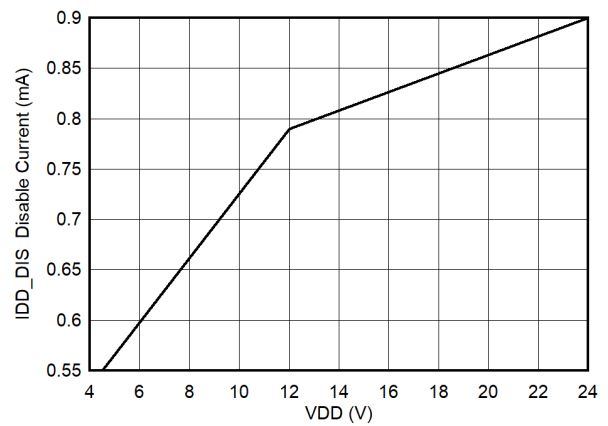

图 6-8. Input Thresholds

6.8 Typical Characteristics (continued)

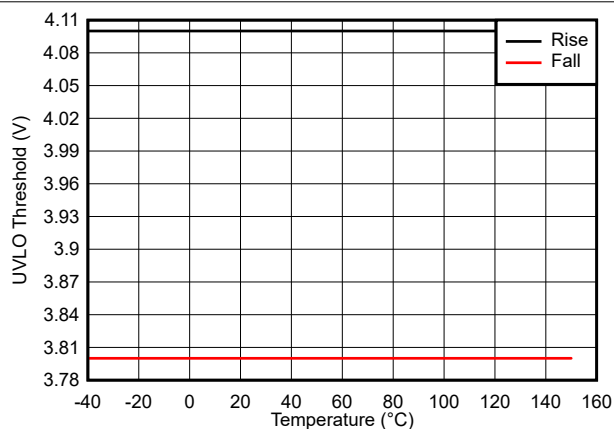
Unless otherwise specified, VDD=12 V, INx=3.3 V, ENx=3.3 V, T_J = 25°C, no load

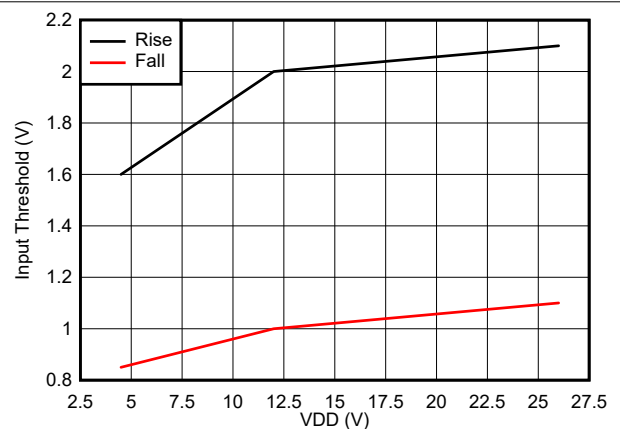
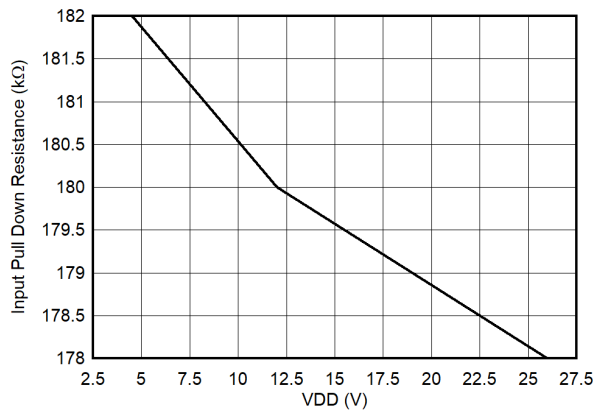

Figure 6-9. Input Pulldown Resistance

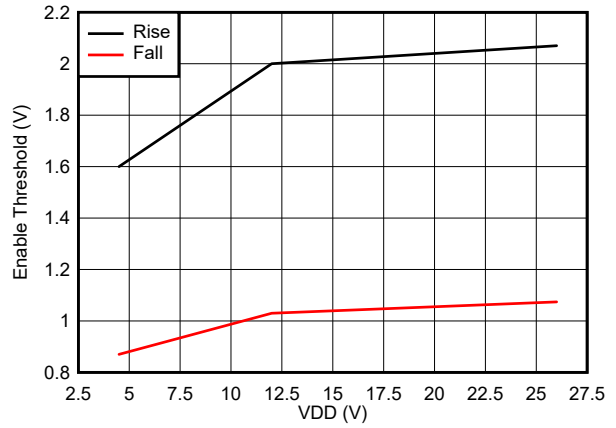

Figure 6-10. Enable Threshold

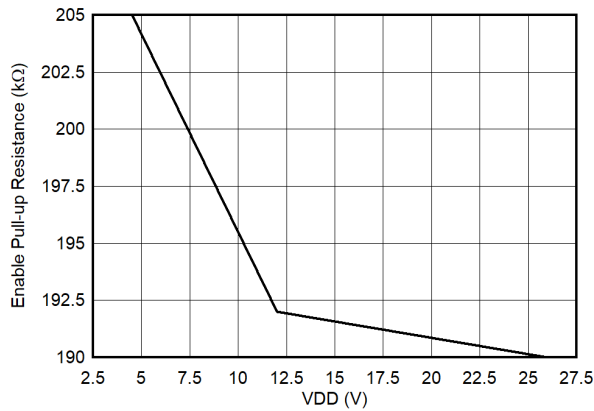

Figure 6-11. Enable Pullup Resistance

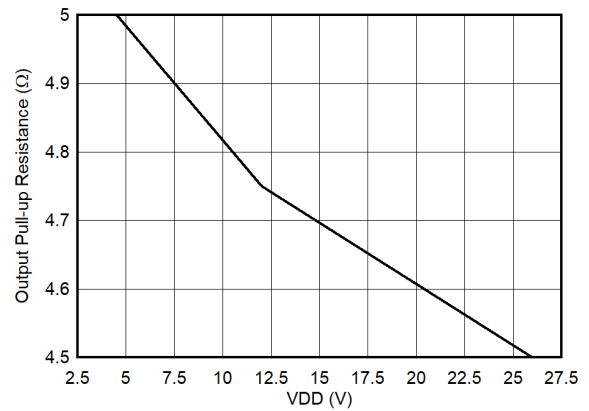

Figure 6-12. Output Pullup Resistance

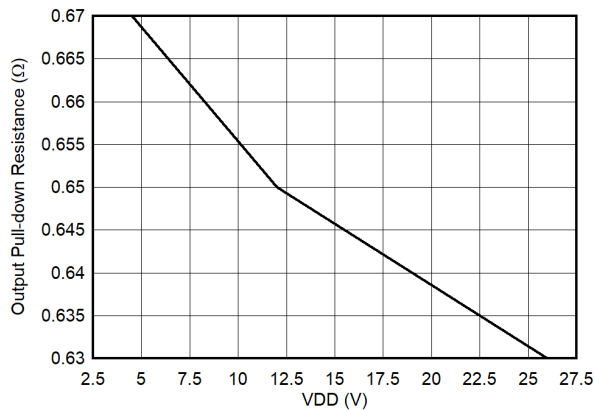

Figure 6-13. Output Pulldown Resistance

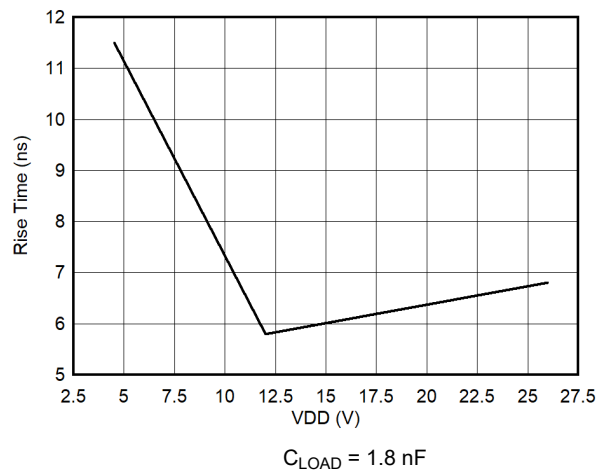
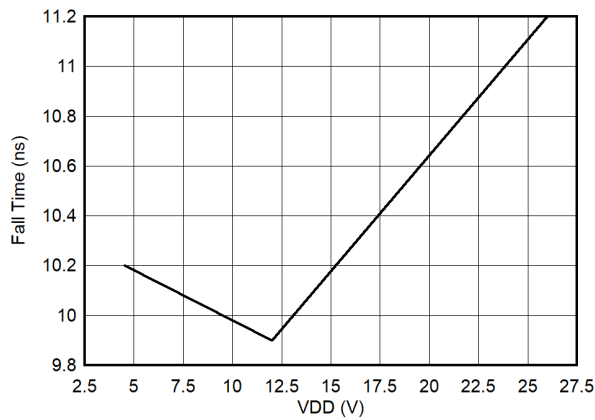

Figure 6-14. Output Rise Time vs VDD

6.8 Typical Characteristics (continued)

Unless otherwise specified, VDD=12 V, INx=3.3 V, ENx=3.3 V, T_J = 25°C, no load



C_{LOAD} = 1.8 nF

图 6-15. Output Fall Time vs VDD

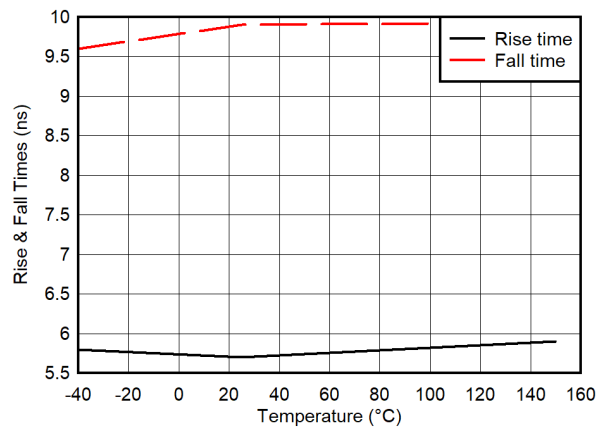

C_{LOAD} = 1.8 nF

图 6-16. Output Rise and Fall Time vs Temperature

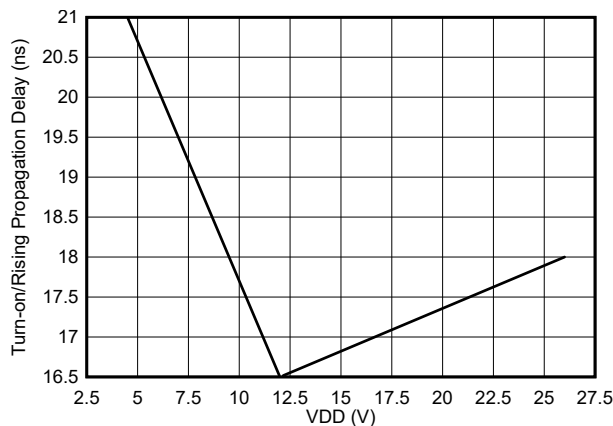

C_{LOAD} = 1.8 nF

图 6-17. Input to Output Rising (Turn-On) Propagation Delay vs VDD

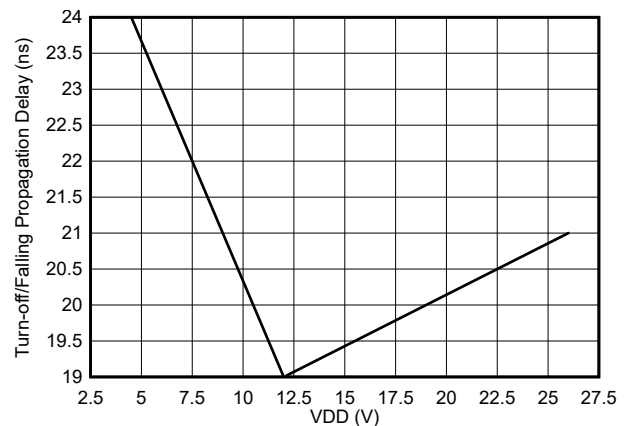

C_{LOAD} = 1.8 nF

图 6-18. Input to Output Falling (Turn-Off) Propagation Delay vs VDD

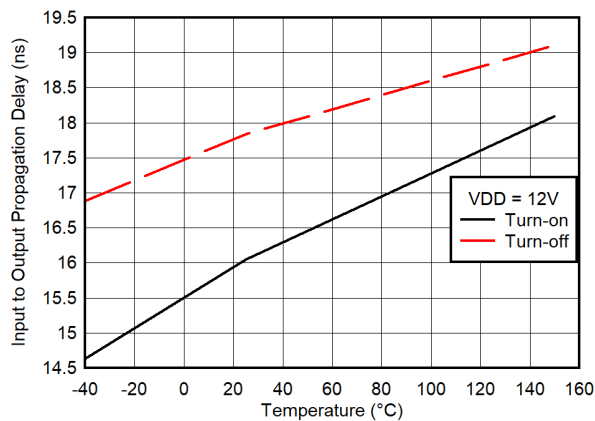

C_{LOAD} = 1.8 nF

图 6-19. Input Propagation Delay vs Temperature

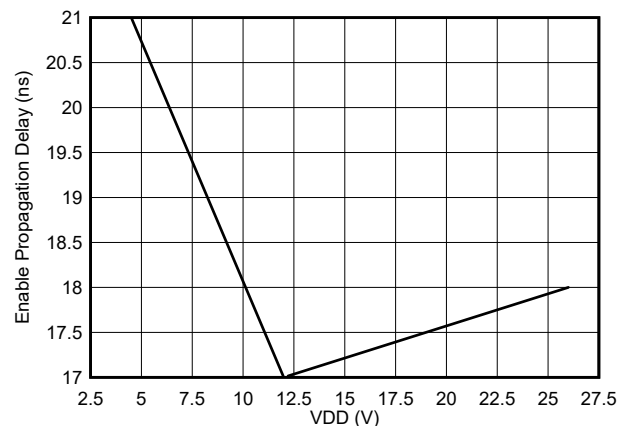

C_{LOAD} = 1.8 nF

图 6-20. Enable to Output Rising Propagation Delay

6.8 Typical Characteristics (continued)

Unless otherwise specified, VDD=12 V, INx=3.3 V, ENx=3.3 V, T_J = 25°C, no load

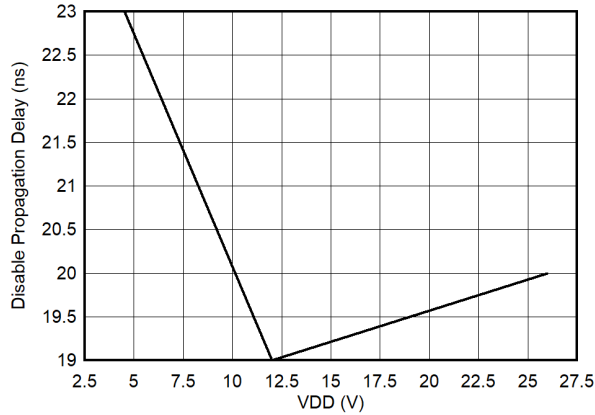

C_{LOAD} = 1.8 nF

Figure 6-21. Enable to Output Falling Propagation Delay

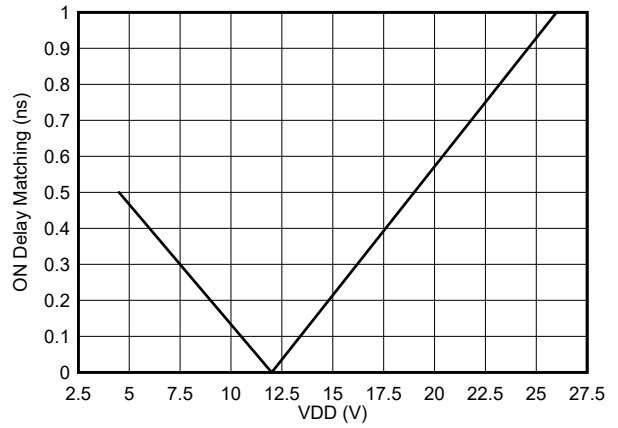

Figure 6-22. Turn-on/Rising Delay Matching

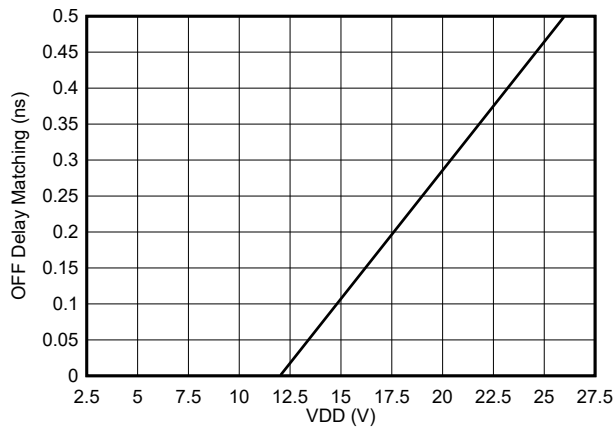

Figure 6-23. Turn-Off and Falling Delay Matching

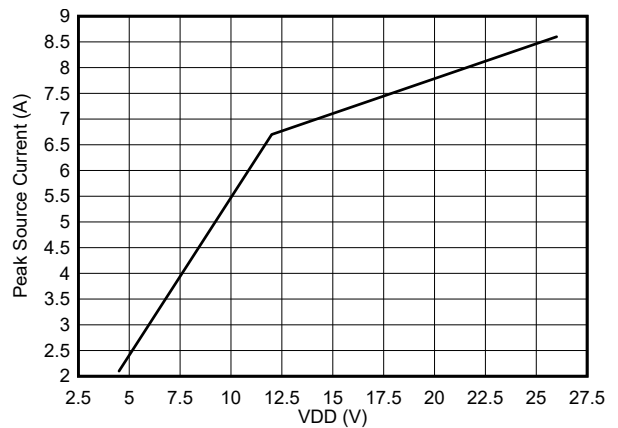

Figure 6-24. Peak Source Current vs VDD

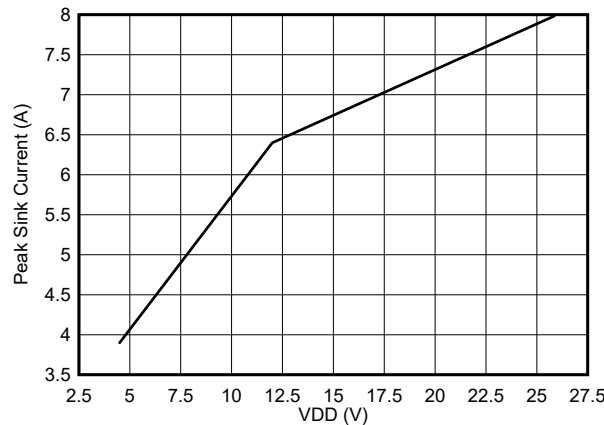

Figure 6-25. Peak Sink Current vs VDD

7 Detailed Description

7.1 Overview

The UCC27524 device represents Texas Instruments' latest generation of dual-channel, low-side, high-speed, gate-driver devices featuring a 5-A source and sink current capability, industry best-in-class switching characteristics, and a host of other features listed in [表 7-1](#) all of which combine to ensure efficient, robust and reliable operation in high-frequency switching power circuits.

表 7-1. UCC27524 Features and Benefits

FEATURE	BENEFIT
Best-in-class 17-ns (typ) propagation delay	Extremely low-pulse transmission distortion
1-ns (typ) delay matching between channels	Ease of paralleling outputs for higher (2 times) current capability, ease of driving parallel-power switches
Expanded VDD Operating range of 4.5 to 18 V	Flexibility in system design
Expanded operating temperature range of $-40\text{ }^{\circ}\text{C}$ to $+150\text{ }^{\circ}\text{C}$ (See Electrical Characteristics table)	Flexibility in system design
VDD UVLO Protection	Outputs are held Low in UVLO condition, which ensures predictable, glitch-free operation at power-up and power-down
Outputs held Low when input pins (INx) in floating condition	Protection feature, especially useful in passing abnormal condition tests during safety certification
Outputs enable when enable pins (ENx) in floating condition	Pin-to-pin compatibility with the UCC27324 device from Texas Instruments, in designs where Pin 1 and Pin 8 are in floating condition
CMOS/TTL compatible input and enable threshold with wide hysteresis	Enhanced noise immunity, while retaining compatibility with microcontroller logic-level input signals (3.3 V, 5 V) optimized for digital power
Ability of input and enable pins to handle voltage levels not restricted by VDD pin bias voltage	System simplification, especially related to auxiliary bias supply architecture
Ability to handle -5 V_{DC} (max) at input pins	Increased robustness in noisy environments

7.2 Functional Block Diagram

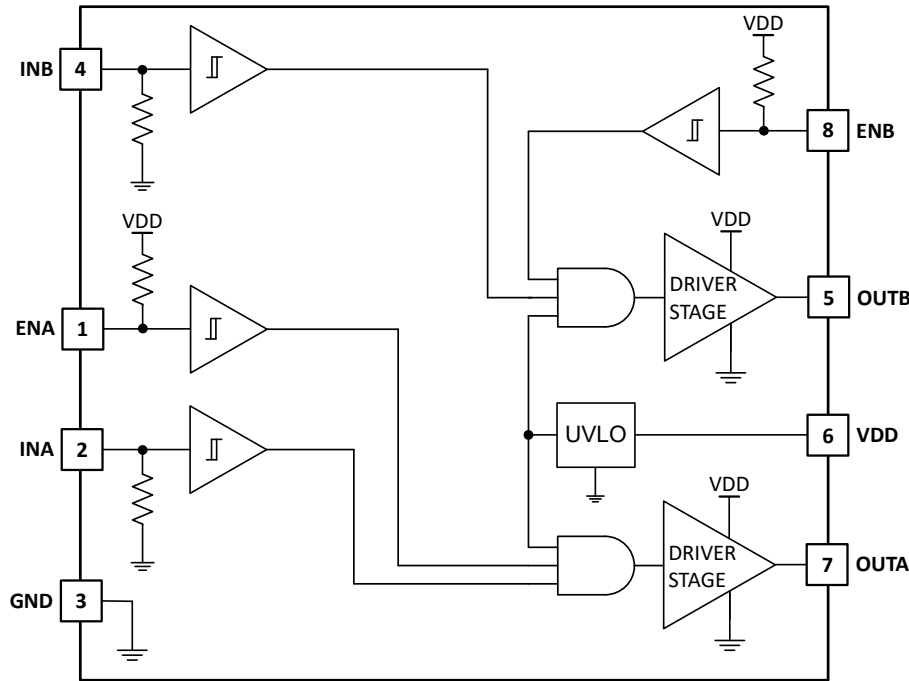

Typical ENx pullup resistance is 200 k Ω and INx pulldown resistance is 120 k Ω .

7.3 Feature Description

7.3.1 Operating Supply Current

The UCC27524 devices feature very low quiescent I_{DD} currents. The typical operating-supply current in UVLO state and fully-on state (under static and switching conditions) are summarized in [Electrical Characteristics](#). The I_{DD} current when the device is fully on and outputs are in a static state (DC high or DC low, see [6-5](#)) represents lowest quiescent I_{DD} current when all the internal logic circuits of the device are fully operational. The total supply current is the sum of the quiescent I_{DD} current, the average I_{OUT} current because of switching, and finally any current related to pullup resistors on the enable pins (see [Functional Block Diagram](#)). Knowing the operating frequency (f_{SW}) and the MOSFET gate (Q_G) charge at the drive voltage being used, the average I_{OUT} current can be calculated as product of Q_G and f_{SW} .

A complete characterization of the I_{DD} current as a function of switching frequency at different V_{DD} bias voltages under 1.8-nF switching load in both channels is provided in [6-4](#). The strikingly linear variation and close correlation with theoretical value of average I_{OUT} indicates negligible shoot-through inside the gate-driver device attesting to its high-speed characteristics.

7.3.2 Input Stage

The input pins of the UCC27524 gate-driver devices are based on a TTL and CMOS compatible input-threshold logic that is independent of the V_{DD} supply voltage. With typically high threshold = 2V and typically low threshold = 1 V, the logic level thresholds are conveniently driven with PWM control signals derived from 3.3-V and 5-V digital power-controller devices. Wider hysteresis (typ 1 V) offers enhanced noise immunity compared to traditional TTL logic implementations, where the hysteresis is typically less than 0.5 V. UCC27524 devices also feature tight control of the input pin threshold voltage levels which eases system design considerations and ensures stable operation across temperature (refer to [Typical Characteristics](#)). The very low input capacitance on these pins reduces loading and increases switching speed.

The UCC27524 device features an important protection feature that holds the output of a channel when the respective pin is in a floating condition. This is achieved using GND pulldown resistors on all of the non-inverting input pins (INA, INB), as shown in the device block diagrams.

The input stage of each driver is driven by a signal with a short rise or fall time. This condition is satisfied in typical power supply applications, where the input signals are provided by a PWM controller or logic gates with fast transition times (<200 ns) with a slow changing input voltage, the output of the driver may switch repeatedly at a high frequency. While the wide hysteresis offered in UCC27524 definitely alleviates this concern over most other TTL input threshold devices, extra care is necessary in these implementations. If limiting the rise or fall times to the power device is the primary goal, then an external resistance is highly recommended between the output of the driver and the power device. This external resistor has the additional benefit of reducing part of the gate-charge related power dissipation in the gate driver device package and transferring it into the external resistor itself.

7.3.3 Enable Function

The enable function is an extremely beneficial feature in gate-driver devices, especially for certain applications such as synchronous rectification where the driver outputs disable in light-load conditions to prevent negative current circulation and to improve light-load efficiency.

The UCC27524 device is equipped with independent enable pins (ENx) for exclusive control of each driver-channel operation. The enable pins are based on a non-inverting configuration (active-high operation). Thus when ENx pins are driven high, the drivers are enabled and when ENx pins are driven low, the drivers are disabled. Like the input pins, the enable pins are also based on a TTL and CMOS compatible, input-threshold logic that is independent of the supply voltage and are effectively controlled using logic signals from 3.3-V and 5-V microcontrollers. The UCC27524 devices also feature tight control of the enable-function threshold-voltage levels which eases system design considerations and ensures stable operation across temperature (refer to [Typical Characteristics](#)). The ENx pins are internally pulled up to VDD using pullup resistors as a result of which the outputs of the device are enabled in the default state. Hence the ENx pins are left floating or Not Connected (N/C) for standard operation, where the enable feature is not needed. Essentially, this floating allows the UCC27524 device to be pin-to-pin compatible with TI's previous generation of drivers (UCC27323, UCC27324, and UCC27325 respectively), where Pin 1 and Pin 8 are N/C pins. If the channel A and Channel B inputs and outputs are connected in parallel to increase the driver current capacity, ENA and ENB are connected and driven together.

7.3.4 Output Stage

The UCC27524 device output stage features a unique architecture on the pullup structure, which delivers the highest peak source current when it is most needed, during the Miller plateau region of the power switch turn-on transition (when the power switch drain or collector voltage experiences dV/dt). The device output stage features a hybrid pullup structure using a parallel arrangement of N-Channel and P-Channel MOSFET devices. By turning on the N-Channel MOSFET during a narrow instant when the output changes state from low to high, the gate driver device is able to deliver a brief boost in the peak sourcing current enabling fast turn-on. The on-resistance of this N-channel MOSFET (R_{NMOS}) is approximately 1.04 Ω when activated.



図 7-1. UCC27524 Gate Driver Output Structure

The R_{OH} parameter is a DC measurement and it is representative of the on-resistance of the P-Channel device only. This is because the N-Channel device is held in the off state in DC condition and is turned-on only for a narrow instant when output changes state from low to high. Note that effective resistance of the UCC27524 pull-up stage during the turn-on instance is much lower than what is represented by R_{OH} parameter.

The pull-down structure in the UCC27524 device is simply comprised of a N-Channel MOSFET. The R_{OL} parameter, which is also a DC measurement, is representative of the impedance of the pull-down stage in the device.

Each output stage in the UCC27524 device is capable of supplying 5-A peak source and 5-A peak sink current pulses. The output voltage swings between VDD and GND providing rail-to-rail operation, thanks to the MOS-output stage which delivers very low dropout. The presence of the MOSFET-body diodes also offers low impedance to transient overshoots and undershoots. The outputs of these drivers are designed to withstand 5A of peak reverse current transients without damage to the device.

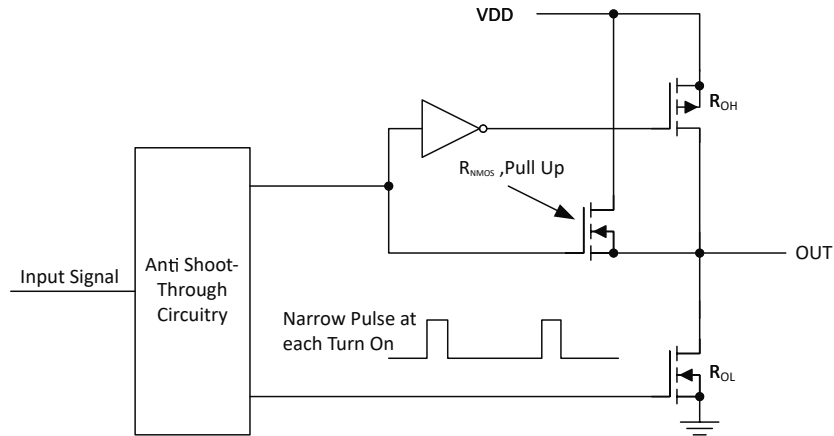
The UCC27524 device is particularly suited for dual-polarity, symmetrical drive-gate transformer applications where the primary winding of transformer driven by OUTA and OUTB, with inputs INA and INB being driven complementary to each other. This is possible because of the extremely low dropout offered by the MOS output stage of these devices, both during high (V_{OH}) and low (V_{OL}) states along with the low impedance of the driver output stage. All of these allow alleviate concerns regarding transformer demagnetization and flux imbalance. The low propagation delays also ensure proper reset for high-frequency applications.

For applications that have zero voltage switching during power MOSFET turn-on or turn-off interval, the driver supplies high-peak current for fast switching even though the miller plateau is not present. This situation often occurs in synchronous rectifier applications because the body diode is generally conducting before power MOSFET is switched on.

7.3.5 Low Propagation Delays and Tightly Matched Outputs

The UCC27524 driver device features a very small, 17-ns (typical) propagation delay between input and output, which offers the lowest level of pulse width distortion for high-frequency switching applications. For example, in synchronous rectifier applications, the SR MOSFETs are driven with very low distortion when a single driver device is used to drive the SR MOSFETs. Additionally, the driver devices also feature extremely accurate, 1-ns (typical) matched internal propagation delays between the two channels, which is beneficial for applications that require dual gate drives with critical timing. For example, in a PFC application, a pair of paralleled MOSFETs can be driven independently using each output channel, with the inputs of both channels driven by a common control signal from the PFC controller. In this case, the 1-ns delay matching ensures that the paralleled MOSFETs are driven in a simultaneous fashion, minimizing turn-on and turn-off delay differences. Another benefit of the tight matching between the two channels is that the two channels can be connected together to effectively double the drive current capability. That is, A and B channels may be combined into a single driver by connecting the INA

and INB inputs together and the OUTA and OUTB outputs together; then, a single signal controls the paralleled power devices.

Caution must be exercised when directly connecting OUTA and OUTB pins together because there is the possibility that any delay between the two channels during turnon or turnoff may result in shoot-through current conduction as shown in [Figure 7-2](#). While the two channels are inherently very well matched (2-ns Max propagation delay), note that there may be differences in the input threshold voltage level between the two channels which causes the delay between the two outputs especially when slow dV/dt input signals are employed. The following guidelines are recommended whenever the two driver channels are paralleled using direct connections between OUTA and OUTB along with INA and INB:

- Use very fast dV/dt input signals (20 V/μs or greater) on INA and INB pins to minimize impact of differences in input thresholds causing delays between the channels.
- INA and INB connections must be made as close to the device pins as possible.

Wherever possible, a safe practice would be to add an option in the design to have gate resistors in series with OUTA and OUTB. This allows the option to use 0-Ω resistors for paralleling outputs directly or to add appropriate series resistances to limit shoot-through current, should it become necessary.

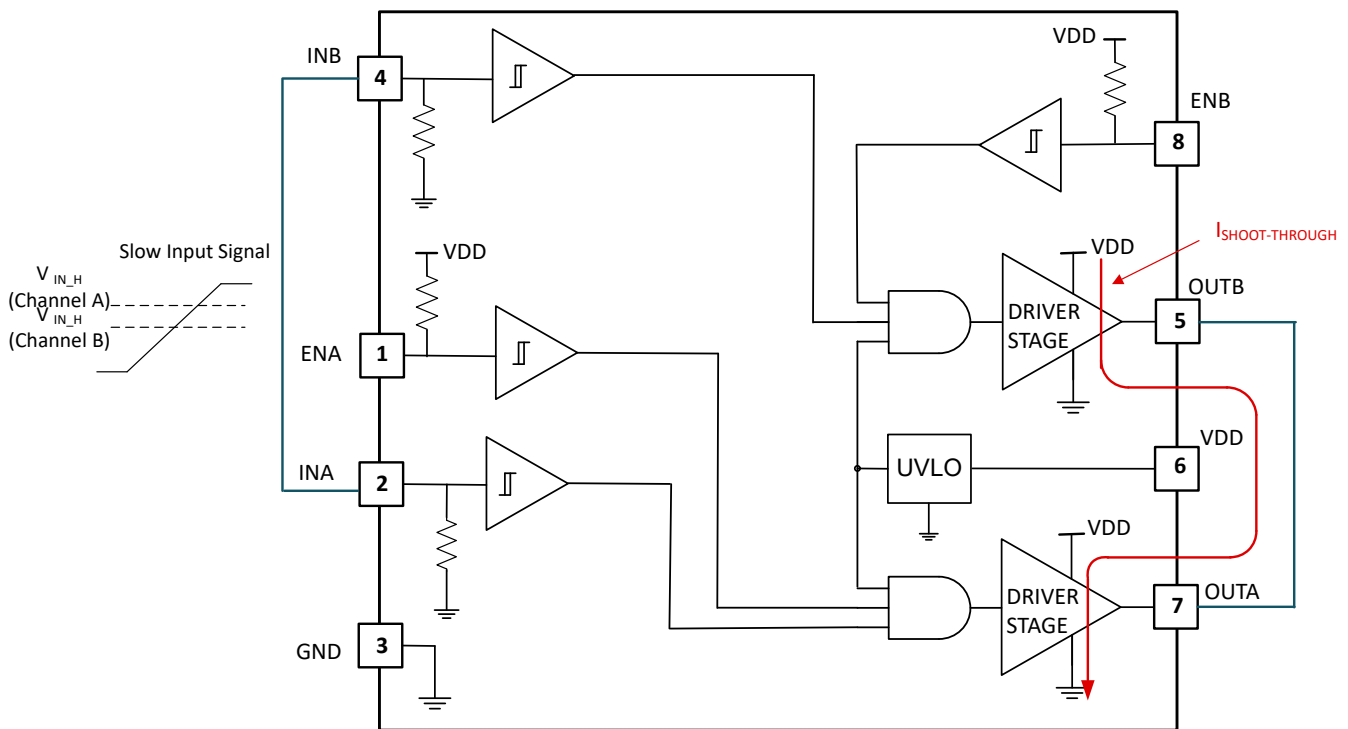

Figure 7-2. Slow Input Signal Can Cause Shoot-Through Between Channels During Paralleling (Recommended DV/DT is 20 V/Ms or Higher)

7.4 Device Functional Modes

Table 7-2. Device Logic Table

ENA	ENB	INA	INB	UCC27524	
				OUTA	OUTB
H	H	L	L	L	L
H	H	L	H	L	H
H	H	H	L	H	L
H	H	H	H	H	H
L	L	Any	Any	L	L

表 7-2. Device Logic Table (続き)

ENA	ENB	INA	INB	UCC27524	
				OUTA	OUTB
Any	Any	x ⁽¹⁾	x ⁽¹⁾	L	L
x ⁽¹⁾	x ⁽¹⁾	L	L	L	L
x ⁽¹⁾	x ⁽¹⁾	L	H	L	H
x ⁽¹⁾	x ⁽¹⁾	H	L	H	L
x ⁽¹⁾	x ⁽¹⁾	H	H	H	H

(1) Floating condition.

8 Application and Implementation

注

Information in the following applications sections is not part of the TI component specification, and TI does not warrant its accuracy or completeness. TI's customers are responsible for determining suitability of components for their purposes, as well as validating and testing their design implementation to confirm system functionality.

8.1 Application Information

High-current gate-driver devices are required in switching power applications for a variety of reasons. In order to effect the fast switching of power devices and reduce associated switching-power losses, a powerful gate-driver device employs between the PWM output of control devices and the gates of the power semiconductor devices. Further, gate-driver devices are indispensable when it is not feasible for the PWM controller device to directly drive the gates of the switching devices. With the advent of digital power, this situation is often encountered because the PWM signal from the digital controller is often a 3.3-V logic signal which is not capable of effectively turning on a power switch. A level-shifting circuitry is required to boost the 3.3-V signal to the gate-drive voltage (such as 12 V) in order to fully turn on the power device and minimize conduction losses. Traditional buffer-drive circuits based on NPN/PNP bipolar transistors in a totem-pole arrangement, as emitter-follower configurations, prove inadequate with digital power because the traditional buffer-drive circuits lack level-shifting capability. Gate-driver devices effectively combine both the level-shifting and buffer-drive functions. Gate-driver devices also find other needs such as minimizing the effect of high-frequency switching noise by locating the high-current driver physically close to the power switch, driving gate-drive transformers and controlling floating power-device gates, reducing power dissipation and thermal stress in controller devices by moving gate-charge power losses into the controller. Finally, emerging wide band-gap power-device technologies such as GaN based switches, which are capable of supporting very high switching frequency operation, are driving special requirements in terms of gate-drive capability. These requirements include operation at low VDD voltages (5 V or lower), low propagation delays, tight delay matching and availability in compact, low-inductance packages with good thermal capability. In summary, gate-driver devices are an extremely important component in switching power combining benefits of high-performance, low-cost, component-count, board-space reduction, and simplified system design.

8.2 Typical Application



図 8-1. UCC27524 Typical Application Diagram

8.2.1 Design Requirements

When selecting the proper gate driver device for an end application, some desiring considerations must be evaluated first in order to make the most appropriate selection. Among these considerations are VDD, UVLO, Drive current and power dissipation.

8.2.2 Detailed Design Procedure

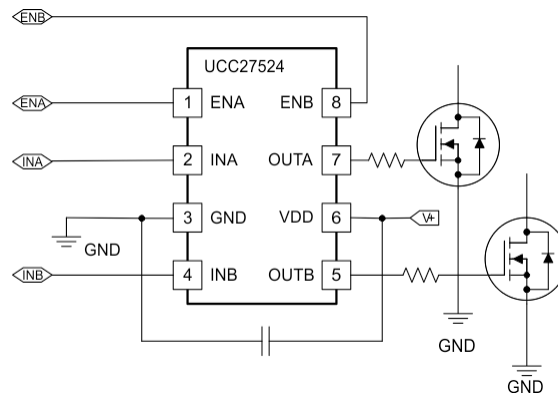
8.2.2.1 VDD and Undervoltage Lockout

The UCC27524 device has an internal undervoltage-lockout (UVLO) protection feature on the VDD pin supply circuit blocks. When VDD is rising and the level is still below UVLO threshold, this circuit holds the output low, regardless of the status of the inputs. The UVLO is typically 4V with 300-mV typical hysteresis. This hysteresis prevents chatter when low VDD supply voltages have noise from the power supply and also when there are droops in the VDD bias voltage when the system commences switching and there is a sudden increase in I_{DD} . The capability to operate at low voltage levels such as below 5 V, along with best in class switching characteristics, is especially suited for driving emerging GaN power semiconductor devices.

For example, at power up, the UCC27524 driver-device output remains low until the V_{DD} voltage reaches the UVLO threshold if enable pin is active or floating. The magnitude of the OUT signal rises with V_{DD} until steady-state V_{DD} is reached. The operation in [Figure 8-2](#) shows that the output remains low until the UVLO threshold is reached, and then the output is in-phase with the input.

Because the device draws current from the VDD pin to bias all internal circuits, for the best high-speed circuit performance, two VDD bypass capacitors are recommended to prevent noise problems. The use of surface mount components is highly recommended. A 0.1- μ F ceramic capacitor must be located as close as possible to the VDD to GND pins of the gate-driver device. In addition, a larger capacitor (such as 1- μ F) with relatively low ESR must be connected in parallel and close proximity, in order to help deliver the high-current peaks required by the load. The parallel combination of capacitors presents a low impedance characteristic for the expected current levels and switching frequencies in the application.

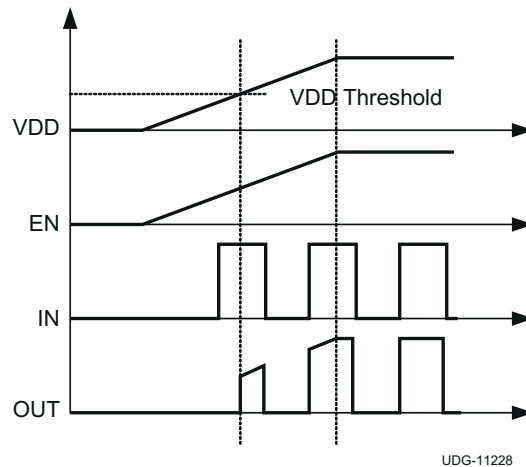

Figure 8-2. Power-Up Non-Inverting Driver

8.2.2.2 Drive Current and Power Dissipation

The UCC27524 driver is capable of delivering 5-A of current to a MOSFET gate for a period of several-hundred nanoseconds at $V_{DD} = 12$ V. High peak current is required to turn the device ON quickly. Then, to turn the device OFF, the driver is required to sink a similar amount of current to ground which repeats at the operating frequency of the power device. The power dissipated in the gate driver device package depends on the following factors:

- Gate charge required of the power MOSFET (usually a function of the drive voltage V_{GS} , which is very close to input bias supply voltage V_{DD} due to low V_{OH} drop-out)
- Switching frequency
- Use of external gate resistors

Because UCC27524 features very low quiescent currents and internal logic to eliminate any shoot-through in the output driver stage, their effect on the power dissipation within the gate driver can be safely assumed to be negligible.

When a driver device is tested with a discrete, capacitive load calculating the power that is required from the bias supply is fairly simple. The energy that must be transferred from the bias supply to charge the capacitor is given by 式 1.

$$E_G = \frac{1}{2} C_{LOAD} V_{DD}^2 \quad (1)$$

where

- C_{LOAD} is the load capacitor
- V_{DD}^2 is the bias voltage feeding the driver

There is an equal amount of energy dissipated when the capacitor is charged. This leads to a total power loss given by 式 2.

$$P_G = C_{LOAD} V_{DD}^2 f_{SW} \quad (2)$$

where

- f_{SW} is the switching frequency

With $V_{DD} = 12\text{ V}$, $C_{LOAD} = 10\text{ nF}$ and $f_{SW} = 300\text{ kHz}$ the power loss is calculated with 式 3.

$$P_G = 10\text{ nF} \times 12\text{ V}^2 \times 300\text{ kHz} = 0.432\text{ W} \quad (3)$$

The switching load presented by a power MOSFET is converted to an equivalent capacitance by examining the gate charge required to switch the device. This gate charge includes the effects of the input capacitance plus the added charge needed to swing the drain voltage of the power device as it switches between the ON and OFF states. Most manufacturers provide specifications that provide the typical and maximum gate charge, in nC, to switch the device under specified conditions. Using the gate charge Q_g , the power that must be dissipated when charging a capacitor is determined which by using the equivalence $Q_g = C_{LOAD} V_{DD}$ to provide 式 4 for power:

$$P_G = C_{LOAD} V_{DD}^2 f_{SW} = Q_g V_{DD} f_{SW} \quad (4)$$

Assuming that the UCC27524 device is driving power MOSFET with 60 nC of gate charge ($Q_g = 60\text{ nC}$ at $V_{DD} = 12\text{ V}$) on each output, the gate charge related power loss is calculated with 式 5.

$$P_G = 2 \times 60\text{ nC} \times 12\text{ V} \times 300\text{ kHz} = 0.432\text{ W} \quad (5)$$

This power P_G is dissipated in the resistive elements of the circuit when the MOSFET turns on or turns off. Half of the total power is dissipated when the load capacitor is charged during turnon, and the other half is dissipated when the load capacitor is discharged during turnoff. When no external gate resistor is employed between the driver and MOSFET/IGBT, this power is completely dissipated inside the driver package. With the use of external gate drive resistors, the power dissipation is shared between the internal resistance of driver and external gate resistor in accordance to the ratio of the resistances (more power dissipated in the higher resistance component). Based on this simplified analysis, the driver power dissipation during switching is calculated as follows (see 式 6):

$$P_{SW} = 0.5 \times Q_G \times V_{DD} \times f_{SW} \times \left(\frac{R_{OFF}}{R_{OFF} + R_{GATE}} + \frac{R_{ON}}{R_{ON} + R_{GATE}} \right) \quad (6)$$

where

- $R_{OFF} = R_{OL}$
- R_{ON} (effective resistance of pullup structure) = $1.5 \times R_{OL}$

In addition to the above gate-charge related power dissipation, additional dissipation in the driver is related to the power associated with the quiescent bias current consumed by the device to bias all internal circuits such as input stage (with pullup and pulldown resistors), enable, and UVLO sections. As shown in 6-4, the quiescent current is less than 0.6 mA even in the highest case. The quiescent power dissipation is calculated easily with 式 7.

$$P_Q = I_{DD} V_{DD} \quad (7)$$

Assuming , $I_{DD} = 6 \text{ mA}$, the power loss is:

$$P_Q = 0.6 \text{ mA} \times 12 \text{ V} = 7.2 \text{ mW} \quad (8)$$

Clearly, this power loss is insignificant compared to gate charge related power dissipation calculated earlier.

With a 12-V supply, the bias current is estimated as follows, with an additional 0.6-mA overhead for the quiescent consumption:

$$I_{DD} \sim \frac{P_G}{V_{DD}} = \frac{0.432 \text{ W}}{12 \text{ V}} = 0.036 \text{ A} \quad (9)$$

8.2.3 Application Curves

The figures below show the typical switching characteristics of the UCC27524 device used in high-voltage boost converter application. In this application, the UCC27524 is driving the IGBT switch that has a gate charge of 110 nC.

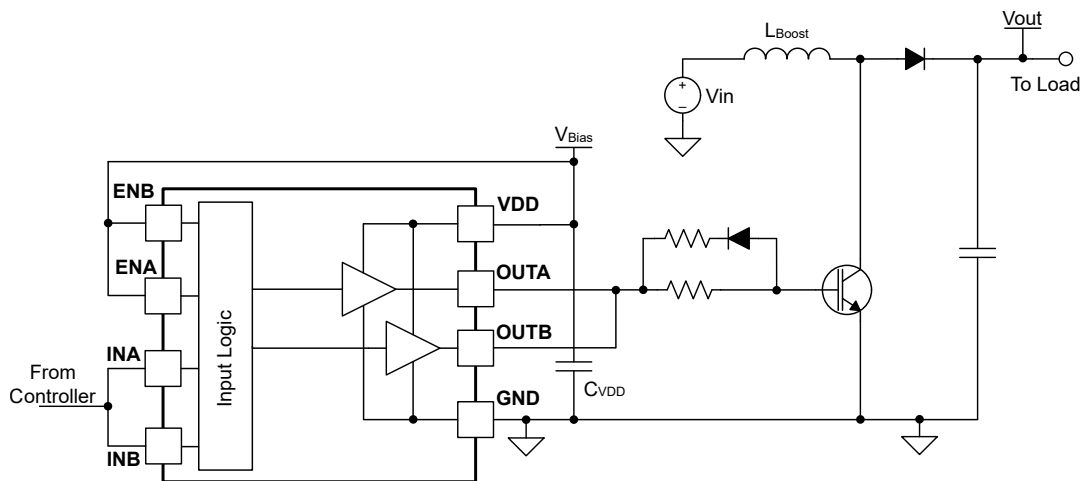

8-3. UCC27524 Used to Drive IGBT in the Boost Converter

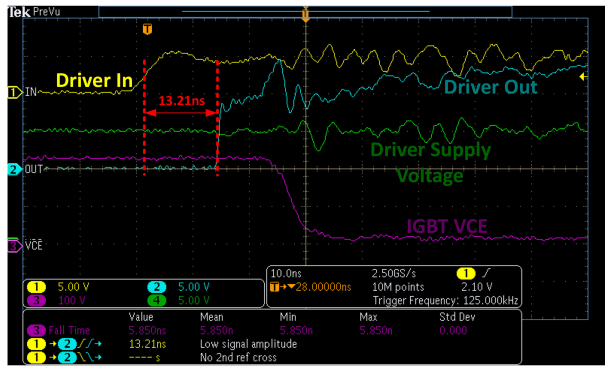

$V_{in} = 210\text{ V}$, $V_{out} = 235\text{ V}$, $I_{out} = 1.14\text{ A}$, $F_{sw} = 125\text{ kHz}$,
 driver supply voltage = 15 V, gate resistor = 0 Ω

図 8-4. Turn-On Propagation Delay Waveform

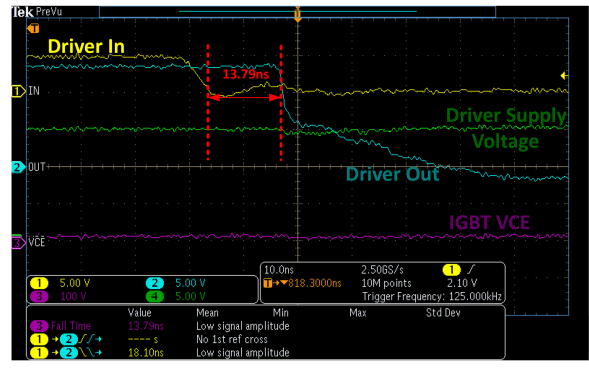

$V_{in} = 210\text{ V}$, $V_{out} = 235\text{ V}$, $I_{out} = 1.14\text{ A}$, $F_{sw} = 100\text{ kHz}$,
 driver supply voltage = 15 V, gate resistor = 0 Ω

図 8-5. Turn-Off Propagation Delay Waveform

9 Power Supply Recommendations

The bias supply voltage range for which the UCC27524 device is rated to operate is from 4.5 V to 18 V. The lower end of this range is governed by the internal undervoltage-lockout (UVLO) protection feature on the V_{DD} pin supply circuit blocks. Whenever the driver is in UVLO condition when the V_{DD} pin voltage is below the V_{ON} supply start threshold, this feature holds the output low, regardless of the status of the inputs. The upper end of this range is driven by the 20-V absolute maximum voltage rating of the V_{DD} pin of the device (which is a stress rating). Keeping a 2-V margin to allow for transient voltage spikes, the maximum recommended voltage for the V_{DD} pin is 18 V.

The UVLO protection feature also involves a hysteresis function. This means that when the V_{DD} pin bias voltage has exceeded the threshold voltage and device begins to operate, and if the voltage drops, then the device continues to deliver normal functionality unless the voltage drop exceeds the hysteresis specification V_{DD_H} . Therefore, ensuring that, while operating at or near the 4.5-V range, the voltage ripple on the auxiliary power supply output is smaller than the hysteresis specification of the device is important to avoid triggering device shutdown. During system shutdown, the device operation continues until the V_{DD} pin voltage has dropped below the V_{OFF} threshold which must be accounted for while evaluating system shutdown timing design requirements. Likewise, at system startup, the device does not begin operation until the V_{DD} pin voltage has exceeded above the V_{ON} threshold.

The quiescent current consumed by the internal circuit blocks of the device is supplied through the V_{DD} pin. Although this fact is well known, recognizing that the charge for source current pulses delivered by the OUTA/B pin is also supplied through the same V_{DD} pin is important. As a result, every time a current is sourced out of the output pins, a corresponding current pulse is delivered into the device through the V_{DD} pin. Thus ensuring that local bypass capacitors are provided between the V_{DD} and GND pins and located as close to the device as possible for the purpose of decoupling is important. A low ESR, ceramic surface mount capacitor is a must. TI recommends having 2 capacitors; a 100-nF ceramic surface-mount capacitor which can be nudged very close to the pins of the device and another surface-mount capacitor of few microfarads added in parallel.

10 Layout

10.1 Layout Guidelines

Proper PCB layout is extremely important in a high-current fast-switching circuit to provide appropriate device operation and design robustness. The UCC27524 gate driver incorporates short propagation delays and powerful output stages capable of delivering large current peaks with very fast rise and fall times at the gate of power MOSFET to facilitate voltage transitions very quickly. At higher V_{DD} voltages, the peak current capability is even higher (5-A peak current is at $V_{DD} = 12\text{ V}$). Very high di/dt causes unacceptable ringing if the trace lengths and impedances are not well controlled. The following circuit layout guidelines are strongly recommended when designing with these high-speed drivers.

- Locate the driver device as close as possible to power device in order to minimize the length of high-current traces between the output pins and the gate of the power device.
- Locate the V_{DD} bypass capacitors between V_{DD} and GND as close as possible to the driver with minimal trace length to improve the noise filtering. These capacitors support high peak current being drawn from V_{DD} during turnon of power MOSFET. The use of low inductance surface-mounted-device (SMD) components such as chip resistors and chip capacitors is highly recommended.
- The turnon and turnoff current loop paths (driver device, power MOSFET and V_{DD} bypass capacitor) must be minimized as much as possible in order to keep the stray inductance to a minimum. High di/dt is established in these loops at two instances during turnon and turnoff transients which induces significant voltage transients on the output pin of the driver device and Gate of the power MOSFET.
- Wherever possible, parallel the source and return traces to take advantage of flux cancellation
- Separate power traces and signal traces, such as output and input signals.
- Star-point grounding is a good way to minimize noise coupling from one current loop to another. The GND of the driver is connected to the other circuit nodes such as source of power MOSFET and ground of PWM controller at one, single point. The connected paths must be as short as possible to reduce inductance and be as wide as possible to reduce resistance.
- Use a ground plane to provide noise shielding. Fast rise and fall times at OUT may corrupt the input signals during transition. The ground plane must not be a conduction path for any current loop. Instead the ground plane must be connected to the star-point with one single trace to establish the ground potential. In addition to noise shielding, the ground plane can help in power dissipation as well
- Exercise caution when replacing the UCC2732x/UCC2742x devices with the UCC27524 device:
 - The UCC27524 device is a much stronger gate driver (5-A peak current versus 4-A peak current).
 - The UCC27524 device is a much faster gate driver (17-ns/17-ns rise and fall propagation delay versus 25-ns/35-ns rise and fall propagation delay).

10.2 Layout Example

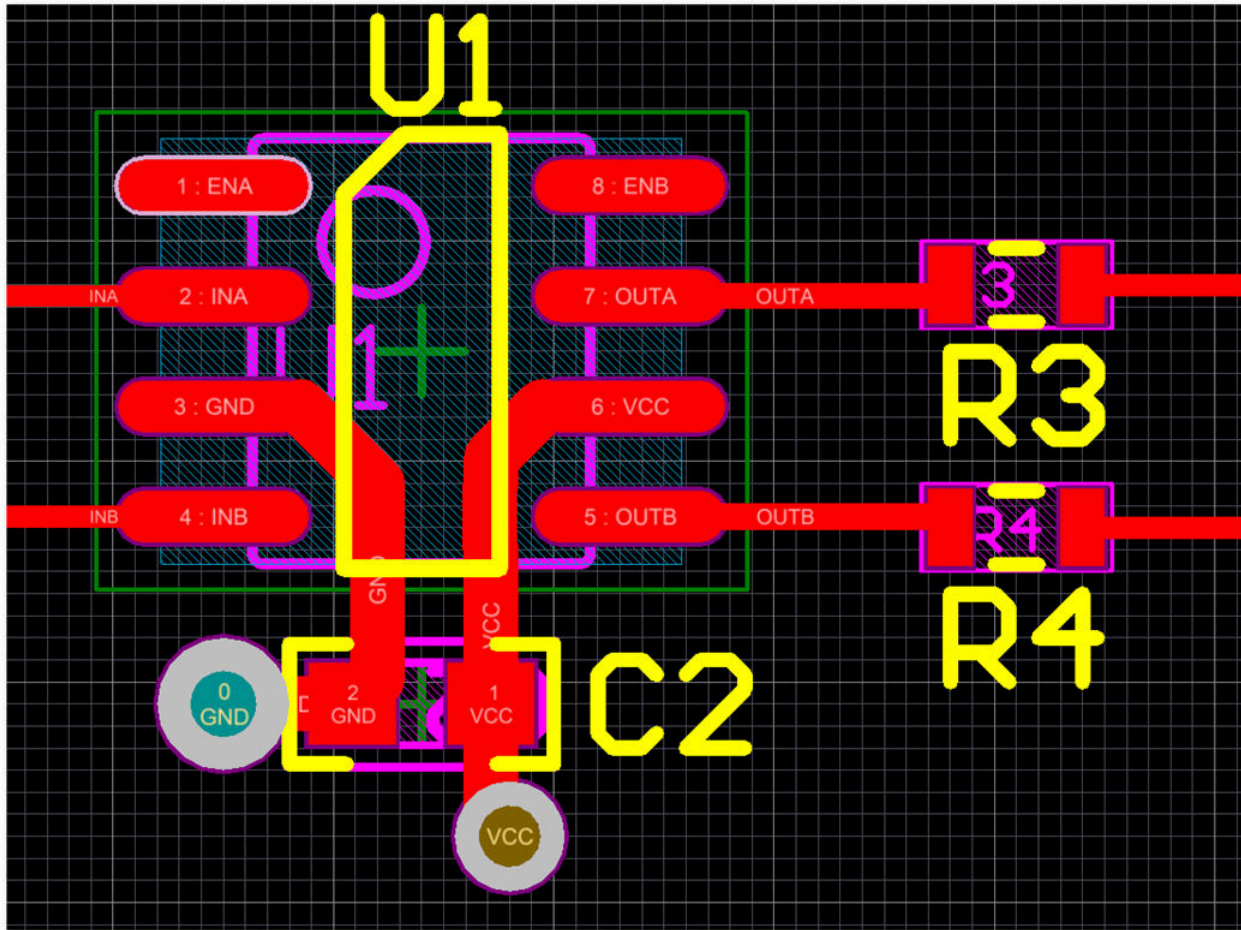

☒ 10-1. UCC27524 Layout Example

10.3 Thermal Considerations

The useful range of a driver is greatly affected by the drive power requirements of the load and the thermal characteristics of the device package. In order for a gate driver device to be useful over a particular temperature range the package must allow for the efficient removal of the heat produced while keeping the junction temperature within rated limits. For detailed information regarding the thermal information table, please refer to Application Note from Texas Instruments entitled, *Semiconductor and IC Package Thermal Metrics* (SPRA953).

Among the different package options available for the UCC27524 device, power dissipation capability of the DGN package is of particular mention. The HVSSOP-8 (DGN) package offers a means of removing the heat from the semiconductor junction through the bottom of the package. This package offers an exposed thermal pad at the base of the package. This pad is soldered to the copper on the printed circuit board directly underneath the device package, reducing the thermal resistance to a very low value. This allows a significant improvement in heat-sinking over that available in the D package. The printed circuit board must be designed with thermal lands and thermal vias to complete the heat removal subsystem. Note that the exposed pads in the HVSSOP-8 package are not directly connected to any leads of the package, however, the PowerPAD is electrically and thermally connected to the substrate of the device which is the ground of the device. TI recommends to externally connect the exposed pads to GND in PCB layout for better EMI immunity.

11 Device and Documentation Support

11.1 Device Support

11.1.1 サード・パーティ製品に関する免責事項

サード・パーティ製品またはサービスに関するテキサス・インスツルメンツの出版物は、単独またはテキサス・インスツルメンツの製品、サービスと一緒に提供される場合に関係なく、サード・パーティ製品またはサービスの適合性に関する是認、サード・パーティ製品またはサービスの是認の表明を意味するものではありません。

11.2 ドキュメントの更新通知を受け取る方法

ドキュメントの更新についての通知を受け取るには、www.tij.co.jp のデバイス製品フォルダを開いてください。[通知] をクリックして登録すると、変更されたすべての製品情報に関するダイジェストを毎週受け取ることができます。変更の詳細については、改訂されたドキュメントに含まれている改訂履歴をご覧ください。

11.3 サポート・リソース

テキサス・インスツルメンツ E2E™ サポート・フォーラムは、エンジニアが検証済みの回答と設計に関するヒントをエキスパートから迅速かつ直接得ることができる場所です。既存の回答を検索したり、独自の質問をしたりすることで、設計に必要な支援を迅速に得ることができます。

リンクされているコンテンツは、各寄稿者により「現状のまま」提供されるものです。これらはテキサス・インスツルメンツの仕様を構成するものではなく、必ずしもテキサス・インスツルメンツの見解を反映したものではありません。テキサス・インスツルメンツの [使用条件](#) を参照してください。

11.4 Trademarks

PowerPAD™ is a trademark of Texas Instruments.

テキサス・インスツルメンツ E2E™ is a trademark of Texas Instruments.

すべての商標は、それぞれの所有者に帰属します。

11.5 静電気放電に関する注意事項



この IC は、ESD によって破損する可能性があります。テキサス・インスツルメンツは、IC を取り扱う際には常に適切な注意を払うことを推奨します。正しい取り扱いおよび設置手順に従わない場合、デバイスを破損するおそれがあります。

ESD による破損は、わずかな性能低下からデバイスの完全な故障まで多岐にわたります。精密な IC の場合、パラメータがわずかに変化するだけで公表されている仕様から外れる可能性があるため、破損が発生しやすくなっています。

11.6 用語集

[テキサス・インスツルメンツ用語集](#) この用語集には、用語や略語の一覧および定義が記載されています。

12 Revision History

資料番号末尾の英字は改訂を表しています。その改訂履歴は英語版に準じています。

DATE	REVISION	NOTES
June 2024	*	Initial Standalone Release

13 Mechanical, Packaging, and Orderable Information

The following pages include mechanical, packaging, and orderable information. This information is the most current data available for the designated devices. This data is subject to change without notice and revision of this document. For browser-based versions of this data sheet, refer to the left-hand navigation.

重要なお知らせと免責事項

テキサス・インスツルメンツは、技術データと信頼性データ (データシートを含みます)、設計リソース (リファレンス デザインを含みます)、アプリケーションや設計に関する各種アドバイス、Web ツール、安全性情報、その他のリソースを、欠陥が存在する可能性のある「現状のまま」提供しており、商品性および特定目的に対する適合性の黙示保証、第三者の知的財産権の非侵害保証を含むいかなる保証も、明示的または黙示的にかかわらず拒否します。

これらのリソースは、テキサス・インスツルメンツ製品を使用する設計の経験を積んだ開発者への提供を意図したものです。(1) お客様のアプリケーションに適した テキサス・インスツルメンツ製品の選定、(2) お客様のアプリケーションの設計、検証、試験、(3) お客様のアプリケーションに該当する各種規格や、その他のあらゆる安全性、セキュリティ、規制、または他の要件への確実な適合に関する責任を、お客様のみが単独で負うものとします。

上記の各種リソースは、予告なく変更される可能性があります。これらのリソースは、リソースで説明されている テキサス・インスツルメンツ製品を使用するアプリケーションの開発の目的でのみ、テキサス・インスツルメンツはその使用をお客様に許諾します。これらのリソースに関して、他の目的で複製することや掲載することは禁止されています。テキサス・インスツルメンツや第三者の知的財産権のライセンスが付与されている訳ではありません。お客様は、これらのリソースを自身で使用した結果発生するあらゆる申し立て、損害、費用、損失、責任について、テキサス・インスツルメンツおよびその代理人を完全に補償するものとし、テキサス・インスツルメンツは一切の責任を拒否します。

テキサス・インスツルメンツの製品は、[テキサス・インスツルメンツの販売条件](#)、または [ti.com](https://www.ti.com) やかかる テキサス・インスツルメンツ製品の関連資料などのいずれかを通じて提供する適用可能な条項の下で提供されています。テキサス・インスツルメンツがこれらのリソースを提供することは、適用されるテキサス・インスツルメンツの保証または他の保証の放棄の拡大や変更を意味するものではありません。

お客様がいかなる追加条項または代替条項を提案した場合でも、テキサス・インスツルメンツはそれらに異議を唱え、拒否します。

郵送先住所: Texas Instruments, Post Office Box 655303, Dallas, Texas 75265

Copyright © 2024, Texas Instruments Incorporated

PACKAGING INFORMATION

Orderable Device	Status (1)	Package Type	Package Drawing	Pins	Package Qty	Eco Plan (2)	Lead finish/ Ball material (6)	MSL Peak Temp (3)	Op Temp (°C)	Device Marking (4/5)	Samples
UCC27524D	ACTIVE	SOIC	D	8	75	RoHS & Green	NIPDAU	Level-1-260C-UNLIM	-40 to 140	27524	Samples
UCC27524DGN	ACTIVE	HVSSOP	DGN	8	80	RoHS & Green	NIPDAUAG	Level-1-260C-UNLIM	-40 to 140	27524	Samples
UCC27524DGNR	ACTIVE	HVSSOP	DGN	8	2500	RoHS & Green	NIPDAUAG	Level-1-260C-UNLIM	-40 to 140	27524	Samples
UCC27524DR	ACTIVE	SOIC	D	8	2500	RoHS & Green	NIPDAU	Level-1-260C-UNLIM	-40 to 140	27524	Samples
UCC27524DSDR	ACTIVE	SON	DSD	8	3000	RoHS & Green	NIPDAU	Level-2-260C-1 YEAR	-40 to 140	SBA	Samples
UCC27524DSDT	ACTIVE	SON	DSD	8	250	RoHS & Green	NIPDAU	Level-2-260C-1 YEAR	-40 to 140	SBA	Samples
UCC27524P	ACTIVE	PDIP	P	8	50	RoHS & Green	NIPDAU	N / A for Pkg Type	-40 to 140	27524	Samples

(1) The marketing status values are defined as follows:

ACTIVE: Product device recommended for new designs.

LIFEBUY: TI has announced that the device will be discontinued, and a lifetime-buy period is in effect.

NRND: Not recommended for new designs. Device is in production to support existing customers, but TI does not recommend using this part in a new design.

PREVIEW: Device has been announced but is not in production. Samples may or may not be available.

OBSOLETE: TI has discontinued the production of the device.

(2) **RoHS:** TI defines "RoHS" to mean semiconductor products that are compliant with the current EU RoHS requirements for all 10 RoHS substances, including the requirement that RoHS substance do not exceed 0.1% by weight in homogeneous materials. Where designed to be soldered at high temperatures, "RoHS" products are suitable for use in specified lead-free processes. TI may reference these types of products as "Pb-Free".

RoHS Exempt: TI defines "RoHS Exempt" to mean products that contain lead but are compliant with EU RoHS pursuant to a specific EU RoHS exemption.

Green: TI defines "Green" to mean the content of Chlorine (Cl) and Bromine (Br) based flame retardants meet JS709B low halogen requirements of <=1000ppm threshold. Antimony trioxide based flame retardants must also meet the <=1000ppm threshold requirement.

(3) MSL, Peak Temp. - The Moisture Sensitivity Level rating according to the JEDEC industry standard classifications, and peak solder temperature.

(4) There may be additional marking, which relates to the logo, the lot trace code information, or the environmental category on the device.

(5) Multiple Device Markings will be inside parentheses. Only one Device Marking contained in parentheses and separated by a "~" will appear on a device. If a line is indented then it is a continuation of the previous line and the two combined represent the entire Device Marking for that device.

⁽⁶⁾ Lead finish/Ball material - Orderable Devices may have multiple material finish options. Finish options are separated by a vertical ruled line. Lead finish/Ball material values may wrap to two lines if the finish value exceeds the maximum column width.

Important Information and Disclaimer:The information provided on this page represents TI's knowledge and belief as of the date that it is provided. TI bases its knowledge and belief on information provided by third parties, and makes no representation or warranty as to the accuracy of such information. Efforts are underway to better integrate information from third parties. TI has taken and continues to take reasonable steps to provide representative and accurate information but may not have conducted destructive testing or chemical analysis on incoming materials and chemicals. TI and TI suppliers consider certain information to be proprietary, and thus CAS numbers and other limited information may not be available for release.

In no event shall TI's liability arising out of such information exceed the total purchase price of the TI part(s) at issue in this document sold by TI to Customer on an annual basis.

重要なお知らせと免責事項

TI は、技術データと信頼性データ（データシートを含みます）、設計リソース（リファレンス・デザインを含みます）、アプリケーションや設計に関する各種アドバイス、Web ツール、安全性情報、その他のリソースを、欠陥が存在する可能性のある「現状のまま」提供しており、商品性および特定目的に対する適合性の黙示保証、第三者の知的財産権の非侵害保証を含むいかなる保証も、明示的または黙示的にかかわらず拒否します。

これらのリソースは、TI 製品を使用する設計の経験を積んだ開発者への提供を意図したものです。(1) お客様のアプリケーションに適した TI 製品の選定、(2) お客様のアプリケーションの設計、検証、試験、(3) お客様のアプリケーションに該当する各種規格や、その他のあらゆる安全性、セキュリティ、規制、または他の要件への確実な適合に関する責任を、お客様のみが単独で負うものとし、

上記の各種リソースは、予告なく変更される可能性があります。これらのリソースは、リソースで説明されている TI 製品を使用するアプリケーションの開発の目的でのみ、TI はその使用をお客様に許諾します。これらのリソースに関して、他の目的で複製することや掲載することは禁止されています。TI や第三者の知的財産権のライセンスが付与されている訳ではありません。お客様は、これらのリソースを自身で使用した結果発生するあらゆる申し立て、損害、費用、損失、責任について、TI およびその代理人を完全に補償するものとし、TI は一切の責任を拒否します。

TI の製品は、[TI の販売条件](#)、または [ti.com](#) やかかる TI 製品の関連資料などのいずれかを通じて提供する適用可能な条項の下で提供されています。TI がこれらのリソースを提供することは、適用される TI の保証または他の保証の放棄の拡大や変更を意味するものではありません。

お客様がいかなる追加条項または代替条項を提案した場合でも、TI はそれらに異議を唱え、拒否します。

郵送先住所：Texas Instruments, Post Office Box 655303, Dallas, Texas 75265
Copyright © 2024, Texas Instruments Incorporated