

UCC2822x インターリーブ制御デュアルPWMコントローラ、最大デューティ・サイクル設定可能

1 特長

- 2MHzの高周波発振器、チャンネルごとに1MHz動作
- マッチングされた内部勾配補償回路
- 最大デューティ・サイクル・クランプをチャンネルごとに60%~90%の範囲でプログラム可能
- ピーク電流モード制御、サイクル単位の電流制限付き
- 電流検出放電トランジスタによるノイズ耐性の向上
- 正確なライン低電圧および過電圧検出、ヒステリシスをプログラム可能
- オプトカプラ・インターフェイス
- 110V内部スタートアップJFET (UCC28221)
- 12V電源で動作(UCC28220)
- プログラム可能なソフト・スタート

2 アプリケーション

- 大出力電流(50A~100A)コンバータ
- 最大電力密度の設計
- 高効率48V入力、低出力リップルのコンバータ
- 大電力のオフライン、テレコム、データコム用電源

3 概要

UCC28220およびUCC28221は、BiCMOSインターリーブ・デュアル・チャンネルPWMコントローラのファミリです。2つのチャンネル間の電流共有を保証するため、ピーク電流モード制御が使用されます。正確な最大デューティ・サイクル・クランプにより、チャンネルごとに60%~90%の範囲内で任意の値にデューティ・サイクルを設定できます。

UCC28220はUVLOターンオン・スレッシュホールドが10Vで、12V電源を使用できます。UCC28221はターンオン・スレッシュホールドが13Vで、より広いUVLOヒステリシスが必要なシステム向けです。どちらもターンオフ・スレッシュホールドは8Vです。

追加機能として、プログラム可能な内部勾配補償(各チャンネルに正確に同じ勾配が追加されることを保証するための特別な回路を搭載)があります。また、UCC28221では高電圧110V内部JFETにより、簡単なスタートアップと、より広いヒステリシスを実現しています。

UCC28220は、16ピンのSOICと低プロファイルのTSSOPパッケージの両方で供給されます。またUCC28221は16ピンのSOICパッケージに加えて、わずかに大きな20ピンのTSSOPパッケージでも供給され、UL1950クリーページ・クリアランス安全性要件を満たす高電圧ピンの間隔を確保できます。

製品情報⁽¹⁾

型番	パッケージ	本体サイズ(typ)
UCC28220、 UCC28221	SOIC (16)	9.00mm×3.90mm
	TSSOP (16)	5.00mm×4.40mm
UCC28221	TSSOP (20)	6.50mm×4.40mm

(1) 提供されているすべてのパッケージについては、巻末の注文情報を参照してください。

代表的なアプリケーション

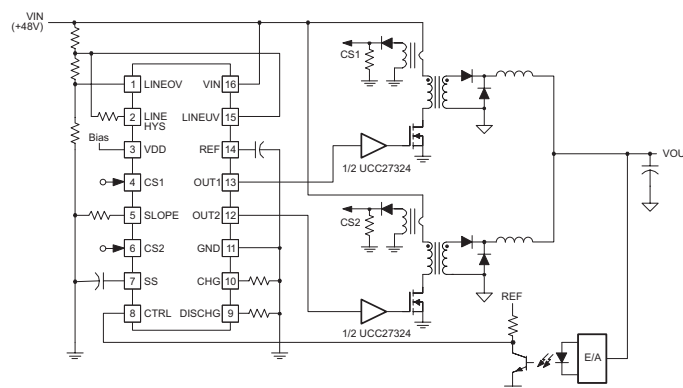

Copyright © 2016, Texas Instruments Incorporated

UCC28220にはJFETオプションが搭載されていないため、ピン16は未接続(NC)です。



目次

1	特長	1	8.4	Device Functional Modes	13
2	アプリケーション	1	9	Application and Implementation	17
3	概要	1	9.1	Application Information	17
4	改訂履歴	2	9.2	Typical Application	17
5	Device Comparison Table	3	10	Power Supply Recommendations	19
6	Pin Configuration and Functions	3	11	Layout	20
7	Specifications	5	11.1	Layout Guidelines	20
7.1	Absolute Maximum Ratings	5	11.2	Layout Example	20
7.2	ESD Ratings	5	12	デバイスおよびドキュメントのサポート	21
7.3	Recommended Operating Conditions	5	12.1	ドキュメントのサポート	21
7.4	Thermal Information	5	12.2	関連リンク	21
7.5	Electrical Characteristics	6	12.3	ドキュメントの更新通知を受け取る方法	21
7.6	Typical Characteristics	8	12.4	コミュニティ・リソース	21
8	Detailed Description	11	12.5	商標	21
8.1	Overview	11	12.6	静電気放電に関する注意事項	21
8.2	Functional Block Diagram	11	12.7	Glossary	22
8.3	Feature Description	12	13	メカニカル、パッケージ、および注文情報	22

4 改訂履歴

Revision F (September 2016) から Revision G に変更

Page

• Deleted Control Loop Compensation section.	19
• Deleted Current Loop section.	19
• Deleted Voltage Loop ($T_{V(s)}$) section.	19

Revision E (March 2009) から Revision F に変更

Page

• 「ESD定格」表、「機能説明」セクション、「デバイスの機能モード」セクション、「アプリケーションと実装」セクション、「電源に関する推奨事項」セクション、「レイアウト」セクション、「デバイスおよびドキュメントのサポート」セクション、「メカニカル、パッケージ、および注文情報」セクション 追加	1
• Deleted <i>Ordering Information</i> table; see POA at the end of the data sheet.	3
• Added <i>Thermal Information</i> table	5

5 Device Comparison Table

DEVICE	DESCRIPTION	PACKAGE OPTION
UCC2732x	Dual 4-A High Speed Low Side MOSFET Drivers	SOIC (8), PowerPAD MSOP (8), PDIP (8)
UCC2742x	Dual 4-A High Speed Low Side MOSFET Drivers with Enable	SOIC (8), PowerPAD MSOP (8), PDIP (8)
TPS281x	Dual 2.4-A High Speed Low Side MOSFET Drivers	SOIC (8), TSSOP (8), PDIP (8)
UC371x	Dual 2.4-A High Speed Low Side MOSFET Drivers	SOIC (8), PowerSOIC (14), PDIP (8)

6 Pin Configuration and Functions

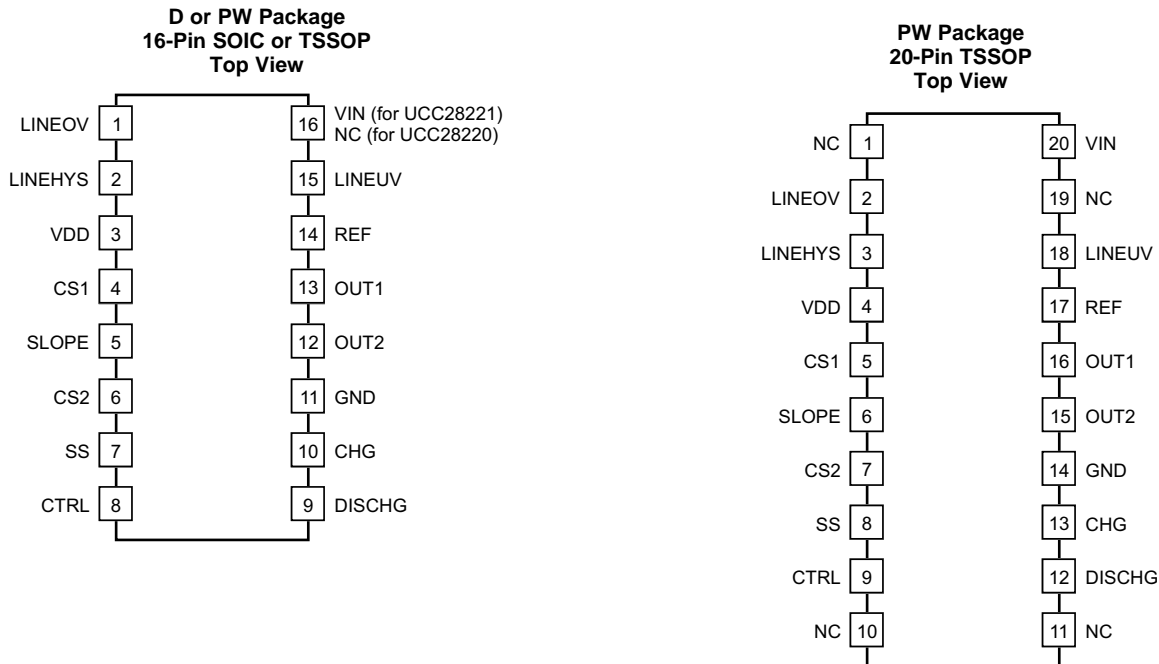

Pin Functions

NAME	PIN		I/O	DESCRIPTION
	SOIC, TSSOP (16)	TSSOP (20)		
CHG	10	13	I	Sets oscillator charge current: A resistor from this pin to GND sets up the charging current of the internal C_T capacitor used in the oscillator. This resistor, in conjunction with the resistor on the DISCHG pin is used to set up the operating frequency and maximum duty cycle. Under normal operation the dc voltage on this pin is 2.5 V.
CS1	4	5	I	Channel 1 current sense input: These 2 pins are the current sense inputs to the device. The signals are internally level shifted by 0.5 V before the signal gets to the PWM comparator. Internally the slope compensation ramp is added to this signal. The linear operating range on this input is 0 to 1.5 V. Also, this pin gets pulled to ground each time its respective output goes low (that is: OUT1 and OUT2).
CS2	6	7	I	Channel 2 current sense input: These 2 pins are the current sense inputs to the device. The signals are internally level shifted by 0.5 V before the signal gets to the PWM comparator. Internally the slope compensation ramp is added to this signal. The linear operating range on this input is 0 to 1.5 V. Also, this pin gets pulled to ground each time its respective output goes low (that is: OUT1 and OUT2).
CTRL	8	9	I	Feedback control input:

Pin Functions (continued)

PIN			I/O	DESCRIPTION
NAME	SOIC, TSSOP (16)	TSSOP (20)		
DISCHG	9	12	I	Sets oscillator discharge current: A resistor from this pin to GND sets up the discharge current of the internal C_T capacitor used in the oscillator. This resistor, in conjunction with the resistor on the CHG pin is used to set up the operating frequency and maximum duty cycle. Under normal operation the dc voltage on this pin is 2.5 V.
GND	11	14	—	Device ground
LINEHYS	2	3	I	Sets line comparator hysteresis: This pin is controlled by both the LINEOV and LINEUV pins. It is used to control the hysteresis values for both the over and under voltage line detectors.
LINEOV	1	2	I	Input for line over voltage comparator: This pin is connected to a comparator and used to monitor the line voltage for an over voltage condition. The typical threshold is 1.26 V.
LINEUV	15	18	I	Input for line under voltage comparator: This pin is connected to a comparator and used to monitor the line voltage for an under voltage condition. The typical threshold is 1.26 V.
N/C	16	1, 10, 11, 19	—	No connection
OUT1	13	16	O	PWM output from channel 1: These output buffers are intended to interface with high current MOSFET drivers. The output drive capability is approximately 33 mA and has an output impedance of 100 Ω . The outputs swing between GND and REF.
OUT2	12	15	O	PWM output from channel 2: These output buffers are intended to interface with high current MOSFET drivers. The output drive capability is approximately 33 mA and has an output impedance of 100 Ω . The outputs swing between GND and REF.
REF	14	17	O	Reference voltage output: REF is a 3.3-V output used primarily as a source for the output buffers and other internal circuits. It is protected from accidental shorts to ground. For improved noise immunity, TI recommends the reference pin be bypassed with a minimum of 0.1 μ F of capacitance to GND.
SLOPE	5	6	I	Sets slope compensation: This pin sets up a current used for the slope compensation ramp. A resistor to ground sets up a current, which is internally divided by 25 and then applied to an internal 10-pF capacitor. Under normal operation the dc voltage on this pin is 2.5 V.
SS	7	8	I	Soft-start input: A capacitor to ground sets up the soft-start time for the open loop soft-start function. The source and sink current from this pin is equal to 3/7th of the oscillator charge current set by the resistor on the CHG pin. The soft start capacitor is held low during UVLO and during a Line OV or UV condition. Once an OV or UV fault occurs, the soft-start capacitor is discharged by a current equal to its charging current. The capacitor does NOT quickly discharge during faults. In this way, the controller has the ability to recover quickly from very short line transients. This pin can also be used as an Enable/Disable function.
VDD	3	4	I	Device supply input: This is used to supply power to the device, monitoring this pin is a the UVLO circuit. This is used to insure glitch-free startup operation. Until VDD reaches its UVLO threshold, it remains in a low power mode, drawing approximately 150 μ A of current and forcing pins, SS, CS1, CS2, OUT1, and OUT2 to logic 0 states. If the VDD falls below 8 V after reaching turnon, it goes back into this low power state. In the case of the UCC28221, the UVLO threshold is 13 V. It is 10 V for the UCC28220. Both versions have a turnoff threshold of 8 V.
VIN	—	20	I	High voltage start-up input: This pin has an internal high voltage JFET used for startup. The drain is connected to VIN, while its' source is connected to VDD. During startup, this JFET delivers 12 mA typically with a minimum of 4 mA to VDD, which in turn, charges up the VDD bypass capacitor. When VDD gets to 13 V, the JFET is turned off.

7 Specifications

7.1 Absolute Maximum Ratings

over operating free-air temperature range (unless otherwise noted)⁽¹⁾

	MIN	MAX	UNIT
High-voltage start-up input, V_{IN}		110	V
Supply voltage, V_{DD}		15	V
Output current (OUT1, OUT2) dc, $I_{OUT(dc)}$		±10	mA
OUT1/ OUT2 capacitive load		200	pF
REF output current, I_{REF}		10	mA
Current sense inputs, CS1, CS2	–1	2	V
Analog inputs (CHG, DISCHG, SLOPE, REF, CNTRL)	–0.3	3.6	V
Analog inputs (SS, LINEOV, LINEUV, LINEHYS)	–0.3	7	V
Power dissipation at $T_A = 25^\circ\text{C}$	PW package	400	mW
	D package	650	
Junction operating temperature, T_J	–55	150	°C
Storage temperature, T_{stg}	–65	150	°C

(1) Stresses beyond those listed under *Absolute Maximum Ratings* may cause permanent damage to the device. These are stress ratings only, which do not imply functional operation of the device at these or any other conditions beyond those indicated under *Recommended Operating Conditions*. Exposure to absolute-maximum-rated conditions for extended periods may affect device reliability.

7.2 ESD Ratings

	VALUE	UNIT
$V_{(ESD)}$ Electrostatic discharge	Human-body model (HBM), per ANSI/ESDA/JEDEC JS-001 ⁽¹⁾	±2500
	Charged-device model (CDM), per JEDEC specification JESD22-C101 ⁽²⁾	±1500

(1) JEDEC document JEP155 states that 500-V HBM allows safe manufacturing with a standard ESD control process.

(2) JEDEC document JEP157 states that 250-V CDM allows safe manufacturing with a standard ESD control process.

7.3 Recommended Operating Conditions

over operating free-air temperature range (unless otherwise noted)

	MIN	MAX	UNIT
V_{IN} High-voltage start-up input	36	76	V
V_{DD} Supply voltage	8.4	14.5	V

7.4 Thermal Information

THERMAL METRIC ⁽¹⁾	UCC28220, UCC28221		UCC28221	UNIT
	D (SOIC)	PW (TSSOP)	PW (TSSOP)	
	16 PINS	16 PINS	20 PINS	
$R_{\theta JA}$ Junction-to-ambient thermal resistance	73	100.9	92.5	°C/W
$R_{\theta JC(top)}$ Junction-to-case (top) thermal resistance	32.6	28.8	27.6	°C/W
$R_{\theta JB}$ Junction-to-board thermal resistance	30.6	46.6	43.7	°C/W
Ψ_{JT} Junction-to-top characterization parameter	5.7	1.4	1.4	°C/W
Ψ_{JB} Junction-to-board characterization parameter	30.3	46	43.2	°C/W
$R_{\theta JC(bot)}$ Junction-to-case (bottom) thermal resistance	—	—	—	°C/W

(1) For more information about traditional and new thermal metrics, see the [Semiconductor and IC Package Thermal Metrics](#) application report.

7.5 Electrical Characteristics

$V_{DD} = 12\text{ V}$, $0.1\text{-}\mu\text{F}$ capacitor from VDD to GND, $0.1\text{-}\mu\text{F}$ capacitor from REF to GND, $F_{OSC} = 1\text{ MHz}$, $T_A = -40^\circ\text{C}$ to 105°C , and $T_A = T_J$ (unless otherwise noted).

PARAMETER	TEST CONDITIONS	MIN	TYP	MAX	UNIT
OVERALL					
Operating VDD		8.4		14.5	V
Quiescent current	SS = 0 V, no switching, $F_{OSC} = 1\text{ MHz}$	1.5	3	4	mA
Operating current	Outputs switching, $F_{OSC} = 1\text{ MHz}$	1.6	3.5	6	mA
START-UP					
Startup current	UCC28220, $V_{DD} < (UVLO - 0.8)$			200	μA
UVLO start threshold	UCC28220	9.5	10	10.5	V
	UCC28221	12.3	13	13.7	
UVLO stop threshold		7.6	8	8.4	V
UVLO hysteresis	UCC28220	1.8	2	2.2	V
	UCC28221	4.8	5	5.2	
JFET ON threshold	SS = 0, outputs not switching, VDD decreasing	9.5	10	10.5	V
	SS = 2 V, Cntrl = 2 V, output switching, VDD decreasing; same threshold as UVLO stop	7.6	8	8.4	
High voltage JFET current	VIN = 36 V to 76 V, VDD = 0 V	16	48	100	mA
	VIN = 36 V to 76 V, VDD = 10 V	4	16	40	
	VIN = 36 V to 76 V, VDD < UVLO	4	12	40	
JFET leakage	VIN = 36 V to 76 V, VDD = 14 V			100	μA
REFERENCE					
Output voltage	$8\text{ V} < V_{DD} < 14\text{ V}$, ILOAD = 0 mA to -10 mA	3.15	3.3	3.45	V
Output current	Outputs not switching, CNTRL = 0 V	10			mA
Output short-circuit current	$V_{REF} = 0\text{ V}$	-40	-20	-10	mA
V_{REF} UVLO		2.55	3	3.25	V
SOFT START					
SS charge current	RCHG = 10.2 k Ω , SS = 0 V	-70	-100	-130	μA
SS discharge current	RCHG = 10.2 k Ω , SS = 2 V	70	100	130	μA
SS initial voltage	LINEOV = 2 V, LINEUV = 0 V	0.5	1	1.5	V
SS voltage at 0% dc	Point at which output starts switching	0.5	1.2	1.8	V
SS voltage ratio		75%	90%	100%	
SS max voltage	LINEOV = 0 V, LINEUV = 2 V	3	3.5	4	V
OSCILLATOR AND PWM					
Output frequency	RCHG = 10.2 k Ω , RDISCHG = 10.2 k Ω	450	500	550	kHz
Oscillator frequency	RCHG = 10.2 k Ω , RDISCHG = 10.2 k Ω	900	1000	1100	kHz
Output maximum duty cycle	RCHG = 10.2 k Ω , RDISCHG = 10.2 k Ω , measured at OUT1 and OUT2	73%	75%	77%	
CHG voltage		2	2.5	3	V
DSCHG voltage		2	2.5	3	V
SLOPE COMPENSATION					
Slope	RSLOPE = 75 k Ω , RCH = 66 k Ω , RDISCHG = 44 k Ω , Csx = 0 V to 0.5 V	140	200	260	mV/us
Channel matching	RSLOPE = 75 k Ω , Csx = 0 V		0%	10%	
CURRENT SENSE					
CS1, CS2 bias current	CS1 = 0, CS2 = 0	-500	0	500	nA
Prop delay CSx to OUTx	CSx input 0 V to 1.5 V step		40	85	ns
CS1, CS2 sink current	CSx = 2 V	2.3	4.5	7	mA

Electrical Characteristics (continued)

$V_{DD} = 12\text{ V}$, $0.1\text{-}\mu\text{F}$ capacitor from VDD to GND, $0.1\text{-}\mu\text{F}$ capacitor from REF to GND, $F_{OSC} = 1\text{ MHz}$, $T_A = -40^\circ\text{C}$ to 105°C , and $T_A = T_J$ (unless otherwise noted).

PARAMETER	TEST CONDITIONS	MIN	TYP	MAX	UNIT
CNTRL					
Resistor ratio ⁽¹⁾			0.6		
Ctrl input current	CTRL = 0 V and 3.3 V	-100	0	100	nA
Ctrl voltage at 0% dc	CSx = 0 V, point at which output starts switching (checks resistor ratio)	0.5	1.2	1.8	V
OUTPUT (OUT1, OUT2)					
Low level	$I_{OUT} = 10\text{ mA}$		0.4	1	V
High level	$I_{OUT} = -10\text{ mA}$, $V_{REF} - V_{OUT}$		0.4	1	V
Rise time	$C_{LOAD} = 50\text{ pF}$		10	20	ns
Fall time	$C_{LOAD} = 50\text{ pF}$		10	20	ns
LINE SENSE					
LINEOV threshold	$T_A = 25^\circ\text{C}$	1.24	1.26	1.28	V
	$T_A = -40^\circ\text{C}$ to 105°C	1.235	1.26	1.285	
LINEUV threshold	$T_A = 25^\circ\text{C}$	1.24	1.26	1.28	V
	$T_A = -40^\circ\text{C}$ to 105°C	1.235	1.26	1.285	
LINEHYST pullup voltage	LINEOV = 2 V, LINEUV = 2 V	3.1	3.25	3.4	V
LINEHYST off leakage	LINEOV = 0 V, LINEUV = 2 V	-500	0	500	nA
LINEHYS pullup resistance	$I = -20\text{ }\mu\text{A}$		100	500	Ω
LINEHYS pulldown resistance	$I = 20\text{ }\mu\text{A}$		100	500	Ω
LINEOV, LINEUV bias I	LINEOV = 1.25 V, LINEUV = 1.25 V	-500		500	nA

(1) Ensured by design. Not 100% tested in production.

7.6 Typical Characteristics

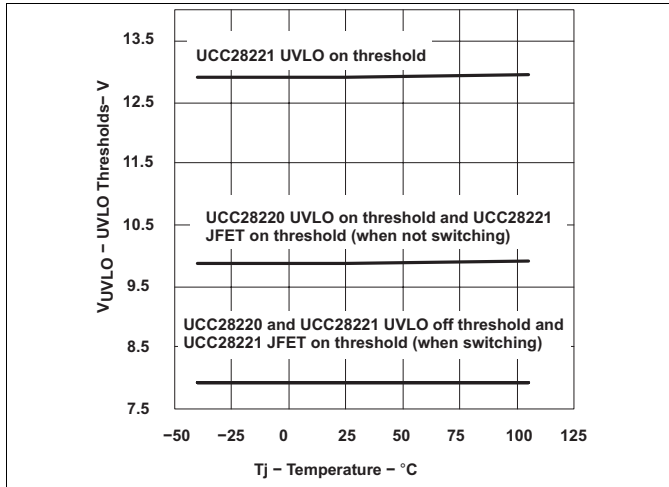

Figure 1. UVLO Thresholds vs Temperature

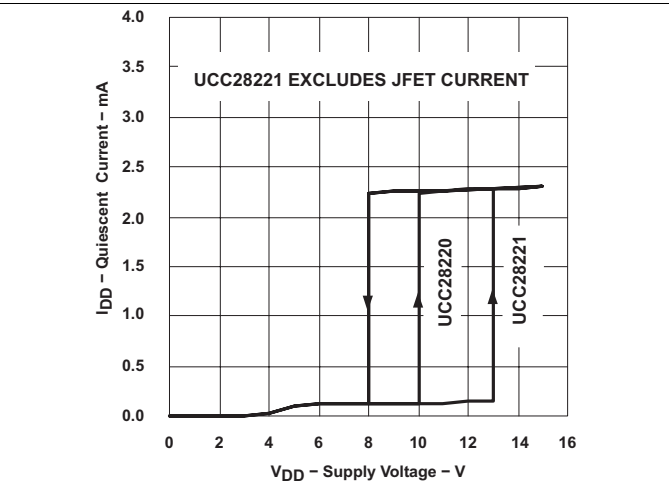

Figure 2. Quiescent Current vs Supply Voltage

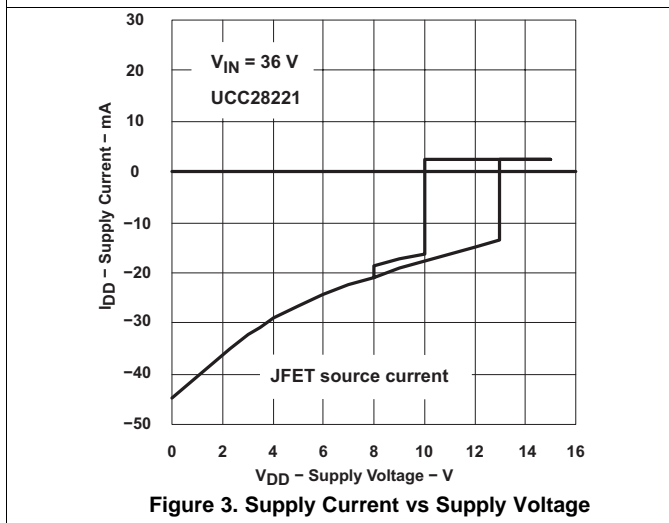

Figure 3. Supply Current vs Supply Voltage

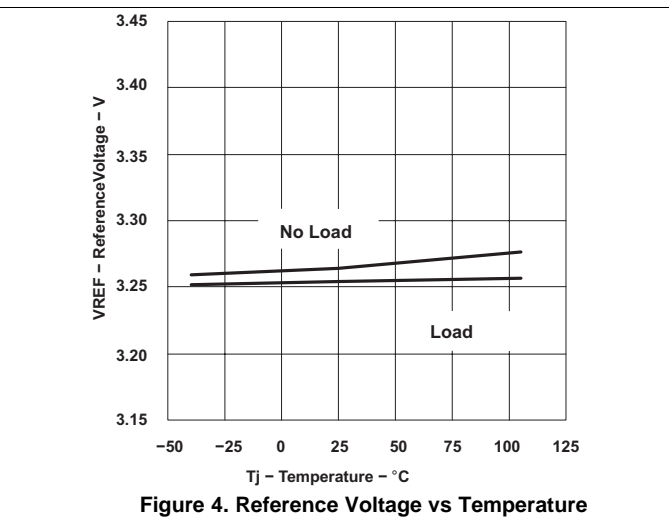

Figure 4. Reference Voltage vs Temperature

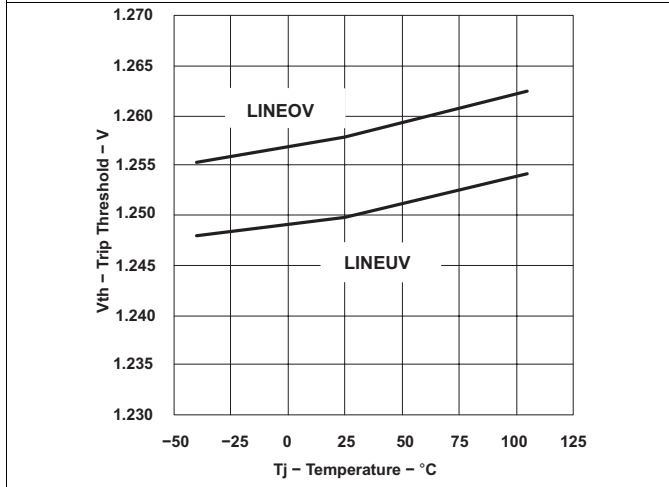

Figure 5. LINEOV and LINEUV Thresholds vs Temperature

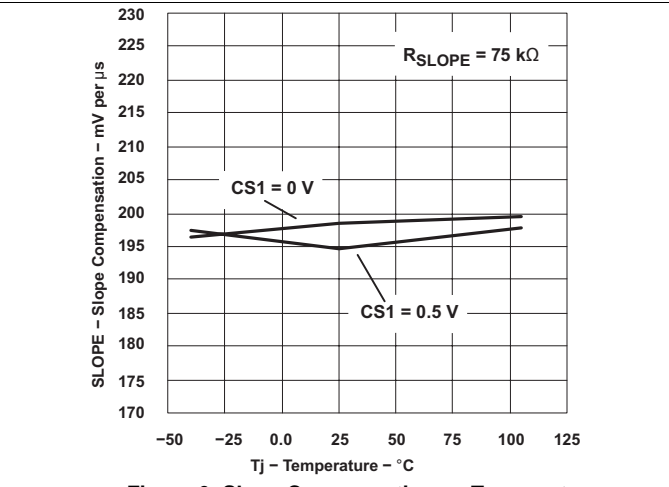

Figure 6. Slope Compensation vs Temperature

Typical Characteristics (continued)

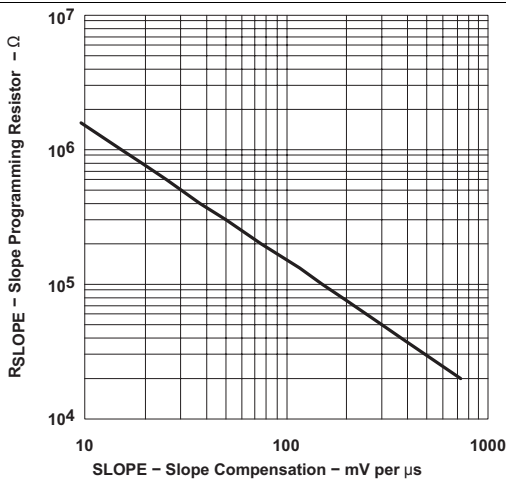

Figure 7. Programming Resistor vs Slope Compensation

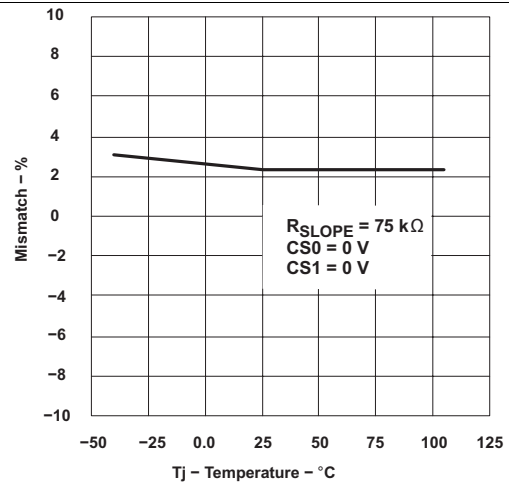
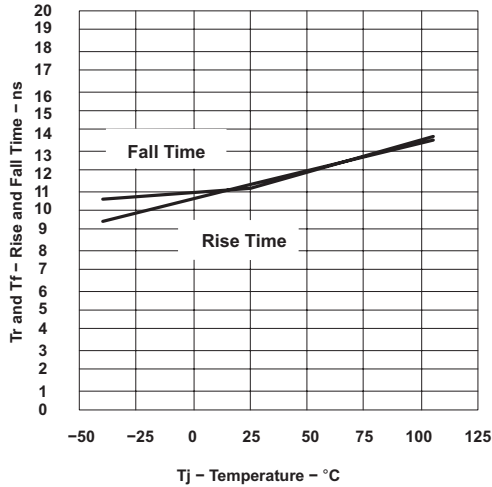

Figure 8. Channel1 and Channel2 Slope Matching vs Temperature



$C_L = 50 \text{ pF}$

Figure 9. Rise and Fall Time vs Temperature

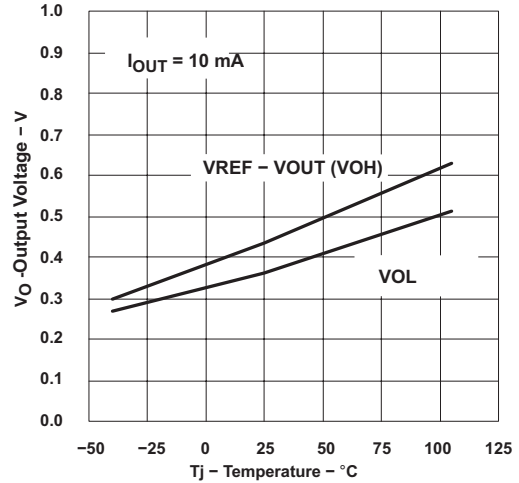

Figure 10. VOH and VOL vs Temperature

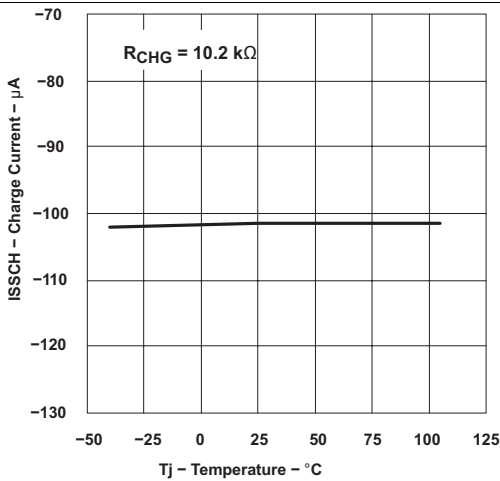

Figure 11. Soft-Start Charge Current vs Temperature

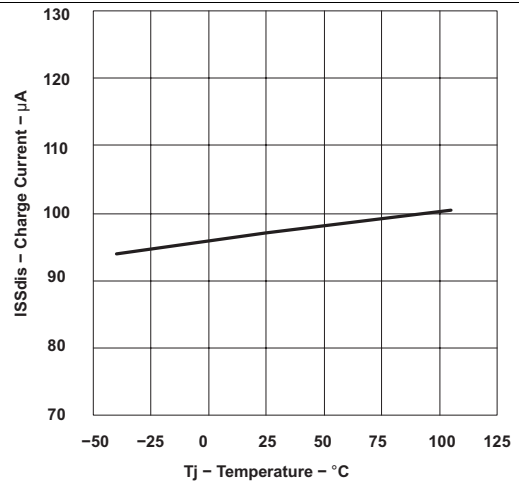

Figure 12. Soft-Start Discharge Current vs Temperature

Typical Characteristics (continued)

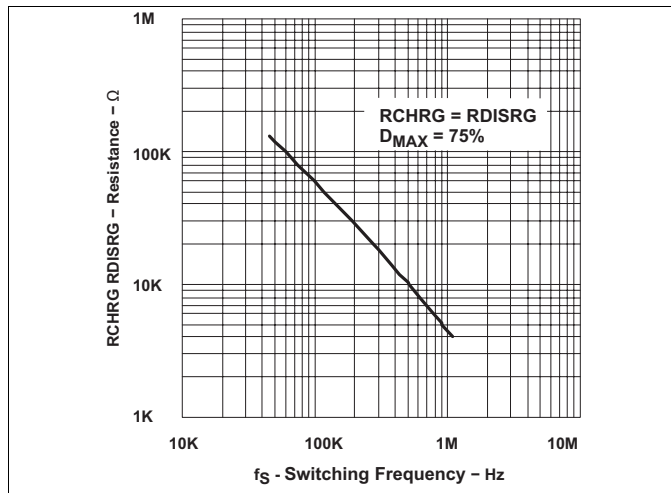

Figure 13. Programming Resistors vs Switching Frequency

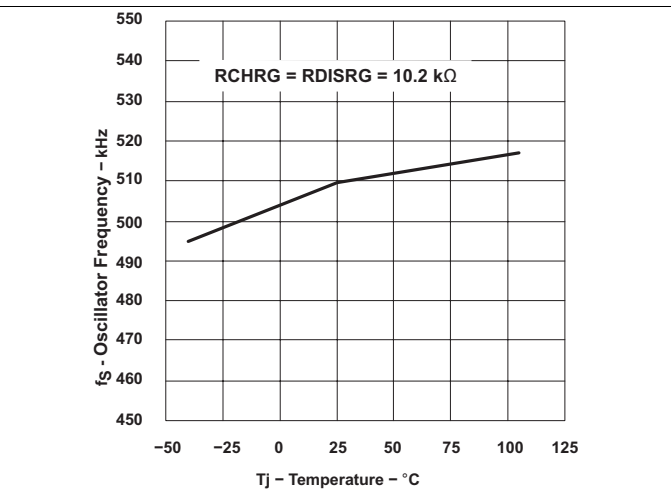

Figure 14. Oscillator Frequency vs Temperature

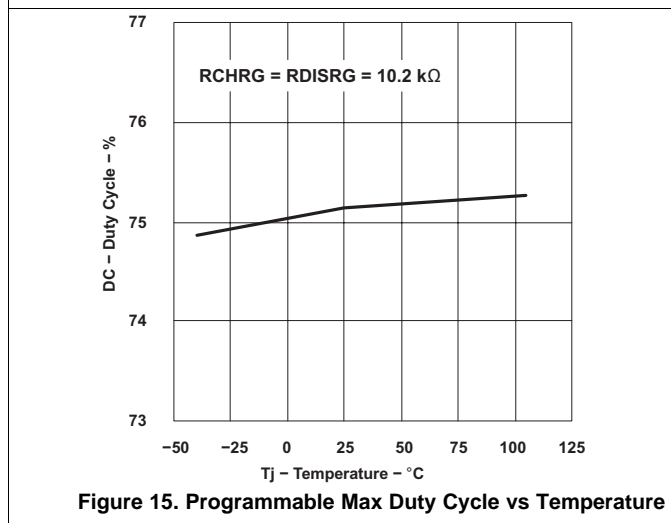

Figure 15. Programmable Max Duty Cycle vs Temperature

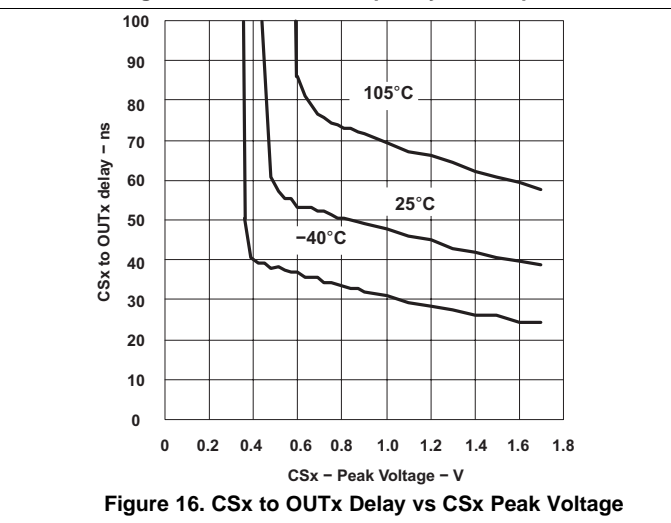

Figure 16. CSx to OUTx Delay vs CSx Peak Voltage

8 Detailed Description

8.1 Overview

The UCC2822x device is comprised of several housekeeping blocks as well as two slope compensated PWM channels that are interleaved. The circuit is intended to run from an external VDD supply voltage between 8 V and 14 V; however, the UCC28221 has the addition of a high-voltage start-up JFET with control circuitry which can be used for system start-up. Other functions contained in the device are supply UVLO, 3.3-V reference, accurate line OV and UV functions, a high-speed programmable oscillator for both frequency and duty cycle, programmable slope compensation, and programmable soft-start functions.

The UCC2822x is a primary side controller for a two-channel interleaved power converter. The device is compatible with forward or flyback converters as long as a duty cycle clamp between 60% and 90% is required. The active clamp forward and flyback converters as well as the RCD and resonant reset forward converters are therefore compatible with this device. To ensure the two channels share the total converter output current, current mode control with internal slope compensation is used. Slope compensation is user programmable through a dedicated pin and can be set over a 50:1 range, ensuring good small-signal stability over a wide range of applications.

8.2 Functional Block Diagram

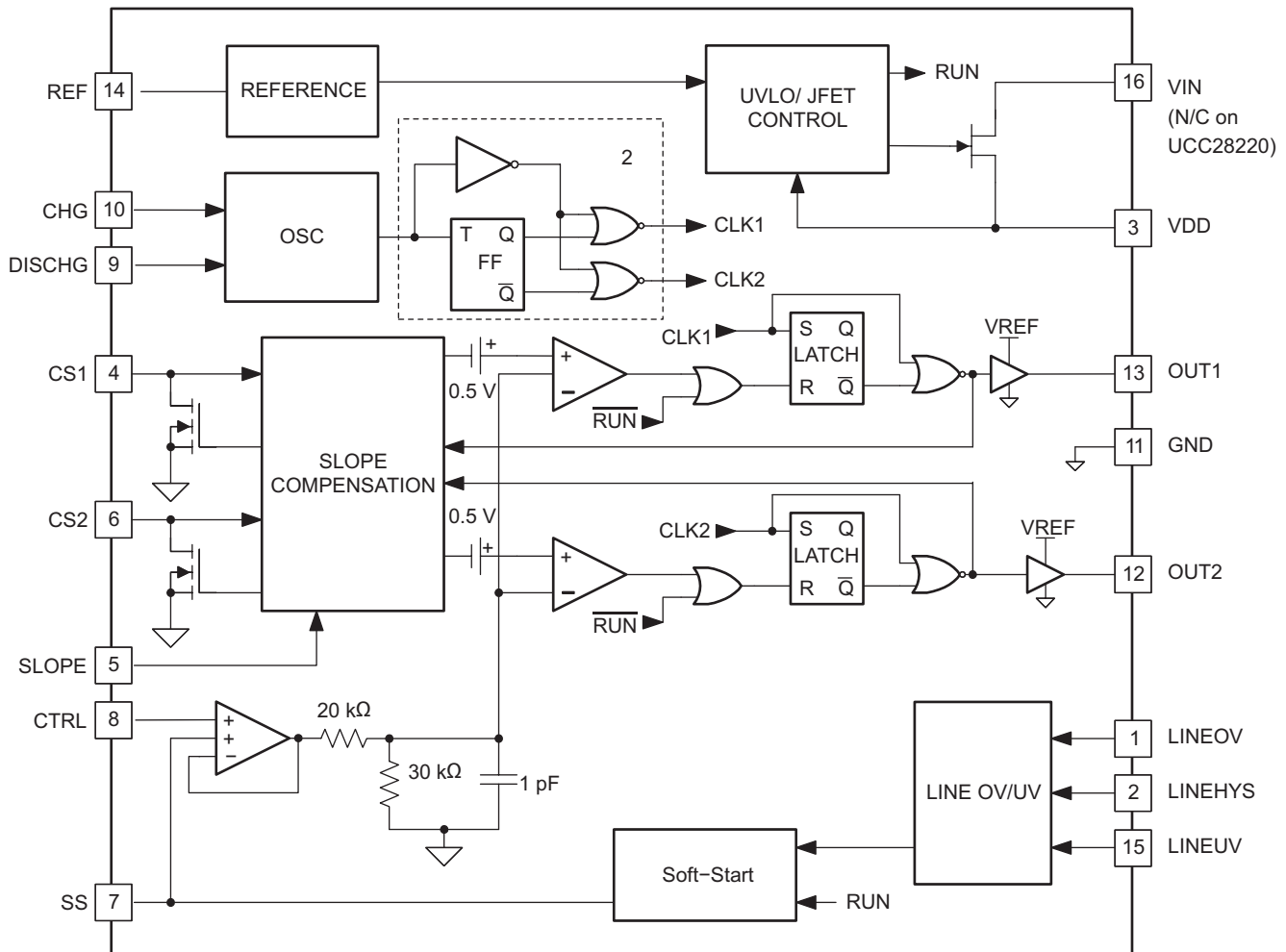

Copyright © 2016, Texas Instruments Incorporated

Pinout for 16 pin option shown. See the 20-pin connection to UCC28221-PW in [Pin Configuration and Functions](#).

8.3 Feature Description

8.3.1 VDD

Because the driver output impedance is high, the energy storage requirement on the VDD capacitor is low. For improved noise immunity, TI recommends that the VDD pin is bypassed with a minimum of 0.1- μ F capacitance to GND. In most typical applications, the bias voltage for the MOSFET drivers is also used as the VDD supply voltage for the chip. It is beneficial to add a low valued resistor between the bulk storage capacitor of the driver and the VDD capacitor for the UCC2822x. By adding a resistor in series with the bias supply with the bias supply, any noise that is present on the bias supply is filtered out before getting to the VDD pin of the controller.

8.3.2 Reference

For improved noise immunity, TI recommends that the reference pin, REF, is bypassed with a minimum of 0.1- μ F capacitance to GND.

8.3.3 Oscillator Operation and Maximum Duty Cycle Setpoint

The oscillator uses an internal capacitor to generate the time base for both PWM channels. The oscillator is programmable over a 200-kHz to 2-MHz frequency range with 20% to 80% maximum duty cycle range. Both the dead time and the frequency of the oscillator are divided by 2 to generate the PWM clock and off-time information for each of the outputs. In this way, a 20% oscillator duty cycle corresponds to a 60% maximum duty cycle at each output, where an 80% oscillator duty cycle yields a 90% duty cycle clamp at each output.

The design equations for the oscillator and maximum duty cycle setpoint are given in [Equation 1](#) through [Equation 4](#).

$$F_{OSC} = 2 \times F_{OUT} \quad (1)$$

$$D_{MAX(osc)} = 1 - 2 \times (1 - D_{MAX(out)}) \quad (2)$$

$$R_{CHG} = K_{OSC} \times \frac{D_{MAX(osc)}}{F_{OSC}} \quad (3)$$

$$R_{DISCHG} = K_{OSC} \times \frac{(1 - D_{MAX(osc)})}{F_{OSC}}$$

where

- $K_{OSC} = 2.04 \times 10^{10}$ (Ω/s)
- F_{OUT} = Switching frequency at the outputs of the chip (Hz)
- $D_{MAX(out)}$ = Maximum duty cycle limit at the outputs of the chip
- $D_{MAX(osc)}$ = Maximum duty cycle of the oscillator for the desired maximum duty cycle at the outputs
- F_{OSC} = Oscillator frequency for desired output frequency (Hz)
- R_{CHG} = External oscillator resistor which sets the charge current (Ω)
- R_{DISCHG} = External oscillator resistor which sets the discharge current (Ω)

8.3.4 Soft Start

A current is forced out of the SS pin, equal to 3/7 of the current set by R_{CHG} , to provide a controlled ramp voltage. The current set by the R_{CHG} resistor is equal to 2.5 V divided by R_{CHG} . This ramp voltage overrides the commanded duty cycle on the CTRL pin, allowing a controlled start-up. Assuming the UCC28221 is biased on the primary side, the soft start must be quite quick to allow the secondary bias to be generated and the secondary side control can then take over. Once the soft-start time interval is complete, a closed-loop soft-start on the secondary side can be executed, such as [Equation 5](#).

$$ISS = \frac{3}{7} \times \frac{2.5}{R_{CHG}}$$

where

- ISS = current which is sourced out of the SS pin during the soft-start time (A)

Feature Description (continued)

8.3.5 Current Sense

The current sense signals CS1 and CS2 are level shifted by 0.5 V and have the slope compensation ramps added to them before being compared to the control voltage at the input of the PMW comparators. The amplitude of the current sense signal at full load must be selected such that it is very close to the maximum control voltage to limit the peak output current during short-circuit operation.

8.3.6 Output Drivers

The UCC2822x is intended to interface with the UCC2732x family of MOSFET drivers. As such, the output drive capability is low, effectively 100 Ω, and the driver output swing between GND and REF.

8.4 Device Functional Modes

8.4.1 Line Overvoltage and Undervoltage

Three pins are provided to turn off the output drivers and reset the soft-start capacitor when the converter input voltage is outside a prescribed range. The undervoltage setpoint and undervoltage hysteresis are accurately set through external resistors. The overvoltage set point is also accurately set through a resistor ratio, but the hysteresis is fixed by the same resistor that set the undervoltage hysteresis.

[Figure 17](#) and [Figure 18](#) show the detailed functional diagram and operation of the undervoltage lockout (UVLO) and overvoltage lockout (OVLO) features. [Equation 6](#) through [Equation 9](#) are for setting the thresholds define in [Figure 18](#).

$$V1 = 1.26 \times \frac{R1}{(R2 + R3)} + 1.26 \tag{6}$$

$$V2 = 1.26 \times \frac{(R1 + Rx)}{Rx}, \text{ where } Rx = R4 \parallel (R2 + R3) \tag{7}$$

$$V4 = 1.26 \times \frac{(R1 + R2 + R3)}{R3} \tag{8}$$

$$V3 = V4 - 1.26 \times \left(\frac{R1}{R4} \right) \tag{9}$$

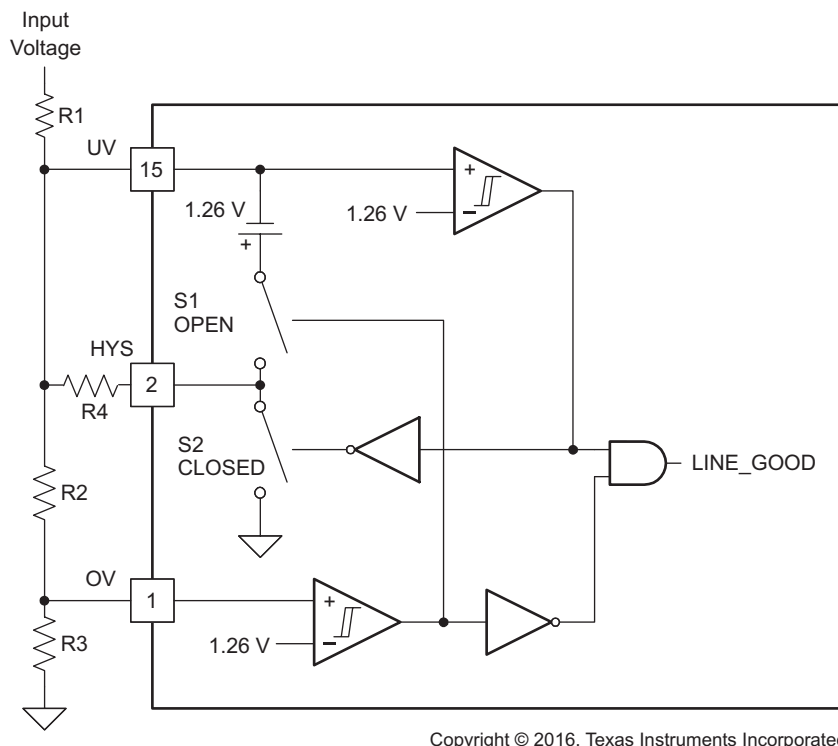
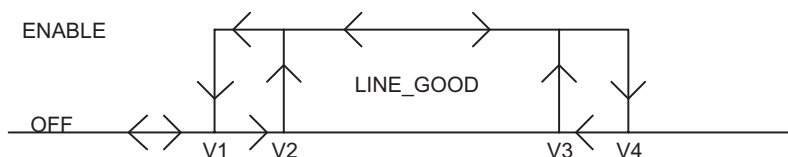
Device Functional Modes (continued)

Figure 17. Line UVLO and OVLO Functional Diagram

Figure 18. Line UVLO and OVLO Operation

The UVLO hysteresis and the OVLO hysteresis can be calculated as $V2 - V1$ and $V4 - V3$, respectively. By examining the design equations, it becomes apparent that the value of $R4$ sets the amount of hysteresis at both thresholds. By realizing this fact, the designer can then set the value of $R4$ based on the most critical hysteresis specification either at high line or at low line. In most designs the value of $R4$ is determined by the desired amount of hysteresis around the UVLO threshold. As an example, consider a telecom power supply with the following input UVLO and OVLO design specifications:

- $V1 = 32 \text{ V}$
- $V2 = 34 \text{ V}$
- $V3 = 83 \text{ V}$
- $V4 = 84.7 \text{ V}$

Then,

- $R1 = 976 \text{ k}\Omega$
- $R2 = 24.9 \text{ k}\Omega$
- $R3 = 15 \text{ k}\Omega$
- $R4 = 604 \text{ k}\Omega$

Device Functional Modes (continued)

8.4.2 Start-Up JFET Section

A 110-V start-up JFET is included to start the device from a wide range (36 V to 75 V) telecom input source. When VDD is lower than 13 V, the JFET is on, behaving as a current source charging the bias capacitors on VDD and supplying current to the device. In this way, the VDD bypass capacitors are charged to 13 V where the outputs start switching and the JFET is turned off. To enable a constant bias supply to the device during a pulse skipping condition, the JFET is turned back on whenever VDD decreases below 10 V and the outputs are not switching. Thus, the current from the JFET can overcome the internal bias currents, as long as the device is not actively switching the output drivers. See Figure 19 for a representation of the JFET and VDD operation. The UCC28220 does not contain an internal JFET and has a start-up threshold of 10 V which makes it capable of directly operating off a 12-V dc bus.

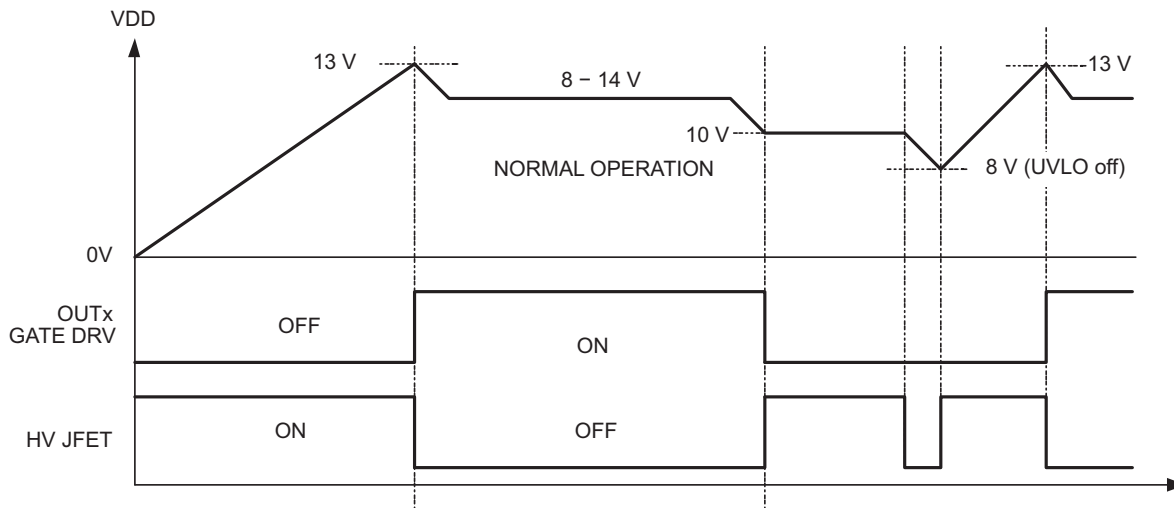
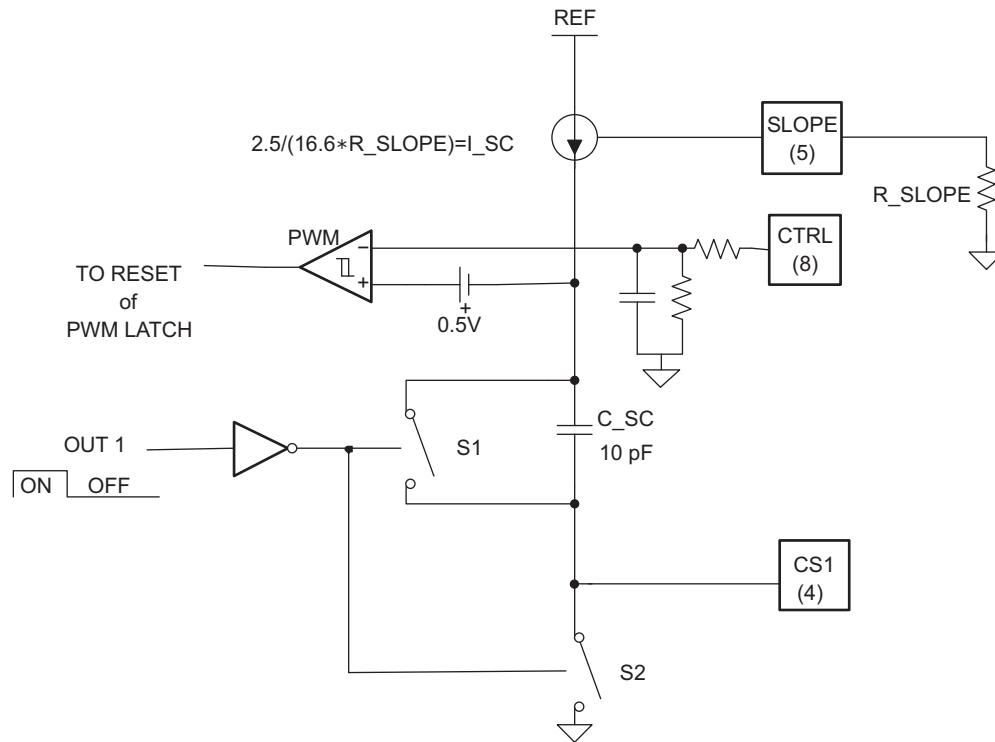

Figure 19. JFET Device Operation With VDD Voltage

8.4.3 Slope Compensation

The slope compensation circuit in the UCC2822x operates on a cycle-by-cycle basis. The two channels have separate slope compensation circuits. These are fabricated in precisely the same way so as current sharing is unaffected by the slope compensation circuit. For each channel, an internal capacitor is reset whenever that channel's output is off. At the beginning of the PWM cycle, a current is mirrored off the SLOPE pin into the capacitor, developing an independent ramp. Because the two channel's ramps start when the channel's output changes from a low to high state, the ramps are thus interleaved. These internal ramps are added to the voltages on the current sense pins, CS1 and CS2, and form an input to the PWM comparators.

Device Functional Modes (continued)

**Figure 20. Slope Compensation Detail for Chanel 1.
Duplicate Matched Circuitry Exists for Channel 2.**

To ensure stability, the slope compensation circuit must add between 1/5 and 1 times the inductor downslope to each of the current sense signals before being applied to the input of the PWM comparator.

9 Application and Implementation

NOTE

Information in the following applications sections is not part of the TI component specification, and TI does not warrant its accuracy or completeness. TI's customers are responsible for determining suitability of components for their purposes. Customers should validate and test their design implementation to confirm system functionality.

9.1 Application Information

The UCC28220 control device from Texas Instruments is used in a dual-interleaved, forward converter that enables the power supply designer to reduce output current ripple and reduce magnetic size per power stage allowing for improved transient response. The UCC28220 is a dual-interleaved PWM controller with programmable maximum duty cycle per channel up to 90% for interleaved forward and interleaved flyback designs.

9.2 Typical Application

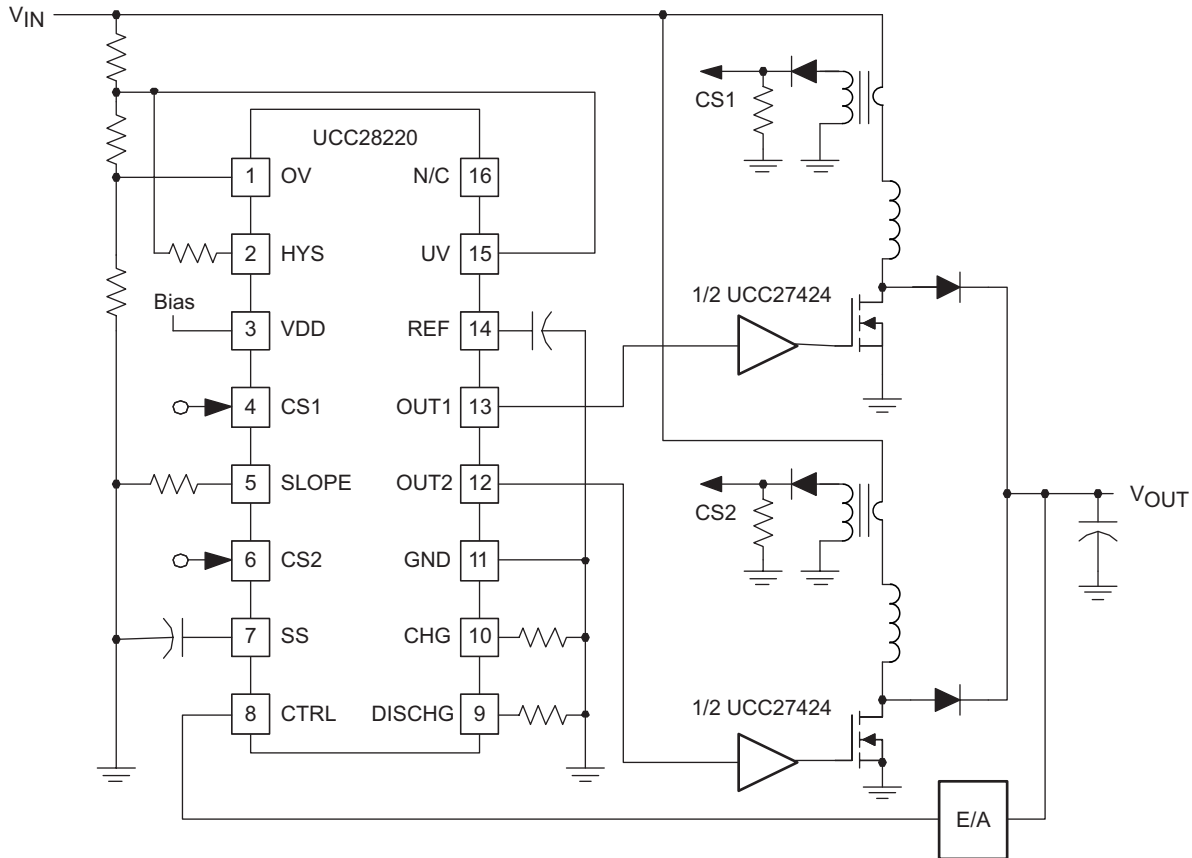

Copyright © 2016, Texas Instruments Incorporated

Figure 21. Interleaved Boost Application Circuit Using the UCC28220

Typical Application (continued)

9.2.1 Design Requirements

Table 1 lists the design parameters for the interleaved boost application circuit.

Table 1. Design Parameters

PARAMETER	MIN	TYP	MAX	UNIT
V _{IN}	85	110 or 230	265	V RMS
V _{OUT}	374	390	425	V
V _{RIPPLE}	—	—	30	V
Current THD at 350 W	—	—	10%	
PF at 350 W	0.95	—	—	
Full load efficiency	90%	—	—	
f _S	—	100	—	kHz
Holdup requirements, t _{HOLD}	—	—	20	ms
f _{LINE}	47	50	60	Hz

9.2.2 Detailed Design Procedure

9.2.2.1 Overvoltage Protection and Undervoltage Lockout

The OVP function and undervoltage lockout (UVLO) were handled by the UCC28220. It is a simple comparator that monitors the boost voltage. The OVP for this design was set to 425 V and UVLO was set to 108 V. The preregulator does not start switching until V_{OUT} reaches 108 V.

9.2.2.2 Peak Current Limit

Peak current limit is set by the maximum control voltage (V_C) at the input of the UCC28220's PWM comparator with Equation 10 through Equation 12. Where *a* is the current sense transformer turns ratio of T1 and T2. The peak current limit trip point was set for 130% of the nominal peak current to protect the boost FETs.

$$a = \frac{N_P}{N_S} = \frac{V_P}{V_S} = \frac{I_S}{I_P} = \frac{1}{50} \quad (10)$$

$$I_{PEAK} = \left(\frac{P_{OUT} \times \sqrt{2}}{2 \times V_{in(min)} \times \eta} + \frac{\Delta IL1}{2} \right) \times 1.3 \quad (11)$$

V_C = 1.8, V_{CTRL} was set to a maximum of 3 V to protect the UCC28220 CTRL pin.

$$R_{SENSE} = \frac{V_C - 0.5 \text{ V}}{I_{PEAK} \times a} \quad (12)$$

Equation 12 considers slope compensation that is added later.

The peak current of the FET during power up is 2 times I_{PEAK} under normal operation as calculated with Equation 13. This is due to the excessive slope compensation that is required for stability.

$$I_{PEAK(startup)} = 2 \times I_{PEAK} \quad (13)$$

9.2.2.3 Current Sense Transformer Reset Resistor (T1 and T2)

$$R_{RESET} = \frac{V_C - 0.5 \text{ V}}{I_{PEAK} \times (1 - D_{MIN(LL)}) \times a} \quad (14)$$

9.2.2.4 Oscillator and Maximum Duty Cycle Clamp

The UCC28220's oscillator and maximum duty cycle clamp are setup through resistor R_{CHG} and discharge. The desired duty cycle clamp (D_{MAX}) was set at 0.9 to stop the current sense transformers from saturating.

$$K_{OSC} = \left(2.04 \times 10^{10}\right) \frac{\Omega}{S} \tag{15}$$

Equation 15 is UCC28220's oscillator constant.

$$F_{OSC} = 2 \times f_S \tag{16}$$

Equation 16 is UCC28220's internal oscillator frequency.

$$F_{OSC} = 2 \times f_S \tag{17}$$

Equation 17 is the internal duty cycle clamp.

$$D_{MAX(OSC)} = 1 - 2(1 - D_{MAX}) \tag{18}$$

$$R_{DISCHG} = K_{OSC} \frac{(1 - D_{MAX(OSC)})}{F_{OSC}} \tag{19}$$

9.2.3 Application Curves

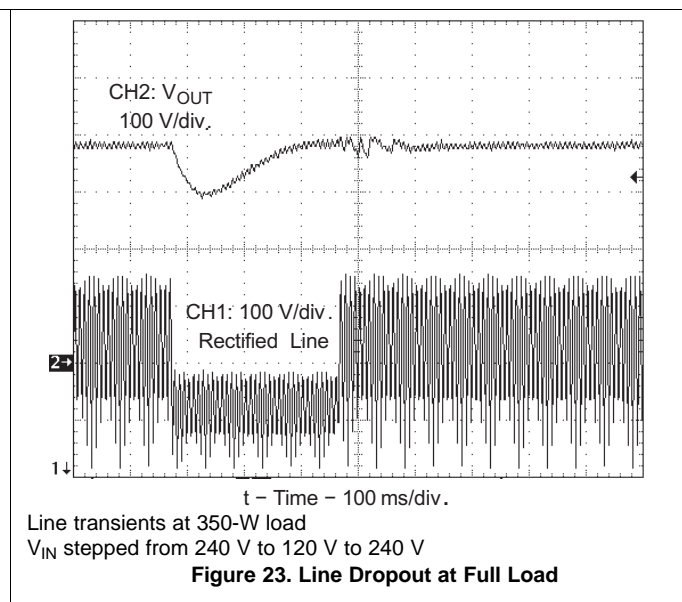
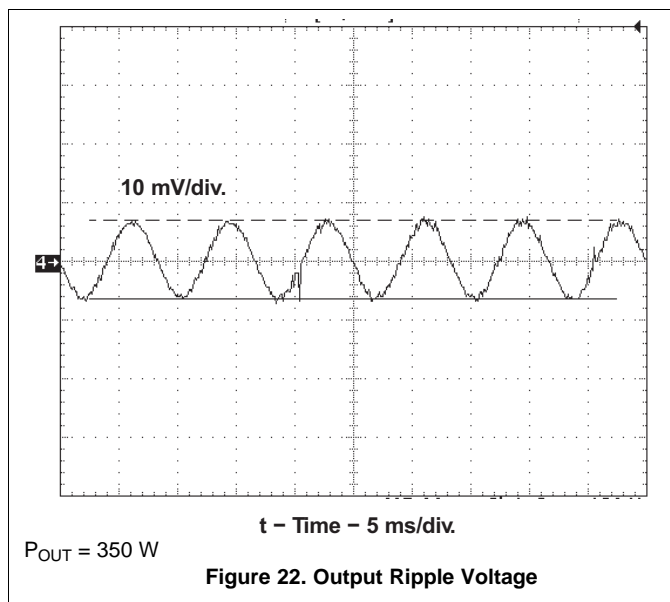

10 Power Supply Recommendations

The VDD power terminal for the device requires the placement of electrolytic capacitor as energy storage capacitor. And requires the placement of low-ESR noise decoupling capacitance as directly as possible from the VDD terminal to the VSS terminal, ceramic capacitors with stable dielectric characteristics over temperature are recommended, such as X7R or better. TI recommends a 1- μ F, 50-V e-capacitor.

11 Layout

11.1 Layout Guidelines

1. TI recommends placing a 1- μ F ceramic decoupling capacitor as close as possible between the VDD terminal and GND, tracked directly to both terminals.
2. TI recommends placing a small, external filter capacitor on the CS1 and CS2 terminal. Track the filter capacitor as directly as possible from the CS to GND terminal.
3. Reduce the total surface area of traces on the CS net to a minimum.
4. Connect decoupling and noise filter capacitors, as well as sensing resistors directly to the GND terminal in a star-point fashion, ensuring that the current-carrying power tracks (such as the gate drive return) are track separately to avoid noise and ground-drops that could affect the analogue signal integrity.

11.2 Layout Example

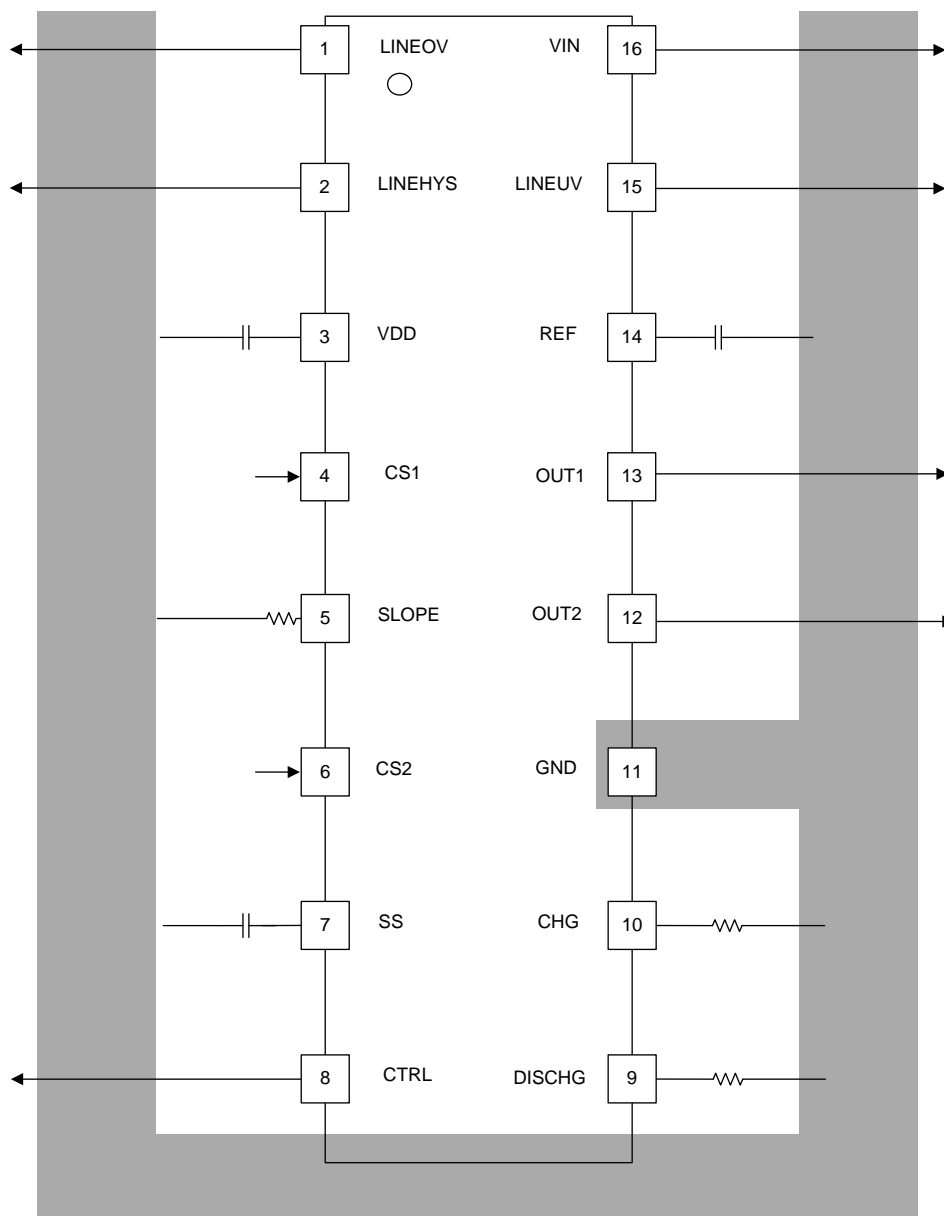

Figure 24. UCC28221 Layout

12 デバイスおよびドキュメントのサポート

12.1 ドキュメントのサポート

12.1.1 関連資料

評価モジュールおよび関連するユーザー・ガイドが利用可能です。UCC28221は2チャンネルのインターリーブ・フォワード設計に使用され、DC 36V～76Vの入力電圧を、レギュレートされたDC 12V出力に変換します。出力モジュールには2つの絶縁された100W順方向電力ステージがあり、500kHzで動作し、互いに180度の位相ずれで動作するため、出力電流のリップルが打ち消され、磁氣的に小さな設計が可能です。この設計では、UCC28221のオンボード110V内部JFETスタートアップ回路も活用しているため、ブートストラップ用の外部トリクル充電抵抗が不要です。この回路は、補助電源がデバイスに供給されるとオフになり、電力を削減します。

『UCC28221 200W評価モジュール(EVM)』(SLUU173)

他の関連資料については、以下を参照してください。

- 『Unitrode - UC3854A/BおよびUC3855A-BにおけるPFCフロントエンドへの正弦入力電流による電力制限』(SLUA196)
- 『トレーリング・エッジトレーリング・エッジ変調付きの先進PFC/PWM混在コントローラ』(SLUS608)

12.2 関連リンク

次の表に、クイック・アクセス・リンクを示します。カテゴリには、技術資料、サポートおよびコミュニティ・リソース、ツールとソフトウェア、およびサンプル注文またはご購入へのクイック・アクセスが含まれます。

表 2. 関連リンク

製品	プロダクト・フォルダ	サンプルとご購入	技術資料	ツールとソフトウェア	サポートとコミュニティ
UCC28220	ここをクリック	ここをクリック	ここをクリック	ここをクリック	ここをクリック
UCC28221	ここをクリック	ここをクリック	ここをクリック	ここをクリック	ここをクリック

12.3 ドキュメントの更新通知を受け取る方法

ドキュメントの更新についての通知を受け取るには、ti.comのデバイス製品フォルダを開いてください。右上の隅にある「通知を受け取る」をクリックして登録すると、変更されたすべての製品情報に関するダイジェストを毎週受け取れます。変更の詳細については、修正されたドキュメントに含まれている改訂履歴をご覧ください。

12.4 コミュニティ・リソース

The following links connect to TI community resources. Linked contents are provided "AS IS" by the respective contributors. They do not constitute TI specifications and do not necessarily reflect TI's views; see TI's [Terms of Use](#).

TI E2E™オンライン・コミュニティ TIのE2E (Engineer-to-Engineer) コミュニティ。エンジニア間の共同作業を促進するために開設されたものです。e2e.ti.comでは、他のエンジニアに質問し、知識を共有し、アイデアを検討して、問題解決に役立てることができます。

設計サポート TIの設計サポート役に立つE2Eフォーラムや、設計サポート・ツールをすばやく見つけることができます。技術サポート用の連絡先情報も参照できます。

12.5 商標

E2E is a trademark of Texas Instruments.

All other trademarks are the property of their respective owners.

12.6 静電気放電に関する注意事項



これらのデバイスは、限定的なESD(静電破壊)保護機能を内蔵しています。保存時または取り扱い時は、MOSゲートに対する静電破壊を防止するために、リード線同士をショートさせておくか、デバイスを導電フォームに入れる必要があります。

12.7 Glossary

[SLYZ022](#) — *TI Glossary*.

This glossary lists and explains terms, acronyms, and definitions.

13 メカニカル、パッケージ、および注文情報

以降のページには、メカニカル、パッケージ、および注文に関する情報が記載されています。この情報は、そのデバイスについて利用可能な最新のデータです。このデータは予告なく変更されることがあり、ドキュメントが改訂される場合もあります。本データシートのブラウザ版を使用されている場合は、画面左側の説明をご覧ください。

PACKAGING INFORMATION

Orderable Device	Status (1)	Package Type	Package Drawing	Pins	Package Qty	Eco Plan (2)	Lead finish/ Ball material (6)	MSL Peak Temp (3)	Op Temp (°C)	Device Marking (4/5)	Samples
UCC28220D	ACTIVE	SOIC	D	16	40	RoHS & Green	NIPDAU	Level-1-260C-UNLIM	-40 to 105	28220	Samples
UCC28220DR	ACTIVE	SOIC	D	16	2500	RoHS & Green	NIPDAU	Level-1-260C-UNLIM	-40 to 105	28220	Samples
UCC28220PW	ACTIVE	TSSOP	PW	16	90	RoHS & Green	NIPDAU	Level-1-260C-UNLIM	-40 to 105	28220	Samples
UCC28220PWR	ACTIVE	TSSOP	PW	16	2000	RoHS & Green	NIPDAU	Level-1-260C-UNLIM	-40 to 105	28220	Samples
UCC28221D	ACTIVE	SOIC	D	16	40	RoHS & Green	NIPDAU	Level-1-260C-UNLIM	-40 to 105	28221	Samples
UCC28221DG4	ACTIVE	SOIC	D	16	40	RoHS & Green	NIPDAU	Level-1-260C-UNLIM	-40 to 105	28221	Samples
UCC28221PW	ACTIVE	TSSOP	PW	20	70	RoHS & Green	NIPDAU	Level-1-260C-UNLIM	-40 to 105	28221	Samples

(1) The marketing status values are defined as follows:

ACTIVE: Product device recommended for new designs.

LIFEBUY: TI has announced that the device will be discontinued, and a lifetime-buy period is in effect.

NRND: Not recommended for new designs. Device is in production to support existing customers, but TI does not recommend using this part in a new design.

PREVIEW: Device has been announced but is not in production. Samples may or may not be available.

OBSOLETE: TI has discontinued the production of the device.

(2) **RoHS:** TI defines "RoHS" to mean semiconductor products that are compliant with the current EU RoHS requirements for all 10 RoHS substances, including the requirement that RoHS substance do not exceed 0.1% by weight in homogeneous materials. Where designed to be soldered at high temperatures, "RoHS" products are suitable for use in specified lead-free processes. TI may reference these types of products as "Pb-Free".

RoHS Exempt: TI defines "RoHS Exempt" to mean products that contain lead but are compliant with EU RoHS pursuant to a specific EU RoHS exemption.

Green: TI defines "Green" to mean the content of Chlorine (Cl) and Bromine (Br) based flame retardants meet JS709B low halogen requirements of <=1000ppm threshold. Antimony trioxide based flame retardants must also meet the <=1000ppm threshold requirement.

(3) MSL, Peak Temp. - The Moisture Sensitivity Level rating according to the JEDEC industry standard classifications, and peak solder temperature.

(4) There may be additional marking, which relates to the logo, the lot trace code information, or the environmental category on the device.

(5) Multiple Device Markings will be inside parentheses. Only one Device Marking contained in parentheses and separated by a "~" will appear on a device. If a line is indented then it is a continuation of the previous line and the two combined represent the entire Device Marking for that device.

⁽⁶⁾ Lead finish/Ball material - Orderable Devices may have multiple material finish options. Finish options are separated by a vertical ruled line. Lead finish/Ball material values may wrap to two lines if the finish value exceeds the maximum column width.

Important Information and Disclaimer:The information provided on this page represents TI's knowledge and belief as of the date that it is provided. TI bases its knowledge and belief on information provided by third parties, and makes no representation or warranty as to the accuracy of such information. Efforts are underway to better integrate information from third parties. TI has taken and continues to take reasonable steps to provide representative and accurate information but may not have conducted destructive testing or chemical analysis on incoming materials and chemicals. TI and TI suppliers consider certain information to be proprietary, and thus CAS numbers and other limited information may not be available for release.

In no event shall TI's liability arising out of such information exceed the total purchase price of the TI part(s) at issue in this document sold by TI to Customer on an annual basis.

OTHER QUALIFIED VERSIONS OF UCC28220 :

- Automotive : [UCC28220-Q1](#)

NOTE: Qualified Version Definitions:

- Automotive - Q100 devices qualified for high-reliability automotive applications targeting zero defects

TAPE AND REEL INFORMATION

QUADRANT ASSIGNMENTS FOR PIN 1 ORIENTATION IN TAPE

*All dimensions are nominal

Device	Package Type	Package Drawing	Pins	SPQ	Reel Diameter (mm)	Reel Width W1 (mm)	A0 (mm)	B0 (mm)	K0 (mm)	P1 (mm)	W (mm)	Pin1 Quadrant
UCC28220DR	SOIC	D	16	2500	330.0	16.4	6.5	10.3	2.1	8.0	16.0	Q1
UCC28220PWR	TSSOP	PW	16	2000	330.0	12.4	6.9	5.6	1.6	8.0	12.0	Q1

TAPE AND REEL BOX DIMENSIONS

*All dimensions are nominal

Device	Package Type	Package Drawing	Pins	SPQ	Length (mm)	Width (mm)	Height (mm)
UCC28220DR	SOIC	D	16	2500	356.0	356.0	35.0
UCC28220PWR	TSSOP	PW	16	2000	356.0	356.0	35.0

TUBE

*All dimensions are nominal

Device	Package Name	Package Type	Pins	SPQ	L (mm)	W (mm)	T (μm)	B (mm)
UCC28220D	D	SOIC	16	40	506.6	8	3940	4.32
UCC28220PW	PW	TSSOP	16	90	530	10.2	3600	3.5
UCC28221D	D	SOIC	16	40	506.6	8	3940	4.32
UCC28221DG4	D	SOIC	16	40	506.6	8	3940	4.32
UCC28221PW	PW	TSSOP	20	70	530	10.2	3600	3.5

PW0020A

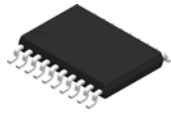

PACKAGE OUTLINE

TSSOP - 1.2 mm max height

SMALL OUTLINE PACKAGE



4220206/A 02/2017

NOTES:

1. All linear dimensions are in millimeters. Any dimensions in parenthesis are for reference only. Dimensioning and tolerancing per ASME Y14.5M.
2. This drawing is subject to change without notice.
3. This dimension does not include mold flash, protrusions, or gate burrs. Mold flash, protrusions, or gate burrs shall not exceed 0.15 mm per side.
4. This dimension does not include interlead flash. Interlead flash shall not exceed 0.25 mm per side.
5. Reference JEDEC registration MO-153.

EXAMPLE BOARD LAYOUT

PW0020A

TSSOP - 1.2 mm max height

SMALL OUTLINE PACKAGE



LAND PATTERN EXAMPLE
EXPOSED METAL SHOWN
SCALE: 10X



SOLDER MASK DETAILS

4220206/A 02/2017

NOTES: (continued)

- 6. Publication IPC-7351 may have alternate designs.
- 7. Solder mask tolerances between and around signal pads can vary based on board fabrication site.

EXAMPLE STENCIL DESIGN

PW0020A

TSSOP - 1.2 mm max height

SMALL OUTLINE PACKAGE



SOLDER PASTE EXAMPLE
BASED ON 0.125 mm THICK STENCIL
SCALE: 10X

4220206/A 02/2017

NOTES: (continued)

8. Laser cutting apertures with trapezoidal walls and rounded corners may offer better paste release. IPC-7525 may have alternate design recommendations.
9. Board assembly site may have different recommendations for stencil design.

D (R-PDSO-G16)

PLASTIC SMALL OUTLINE



- NOTES:
- A. All linear dimensions are in inches (millimeters).
 - B. This drawing is subject to change without notice.
 - C. Body length does not include mold flash, protrusions, or gate burrs. Mold flash, protrusions, or gate burrs shall not exceed 0.006 (0,15) each side.
 - D. Body width does not include interlead flash. Interlead flash shall not exceed 0.017 (0,43) each side.
 - E. Reference JEDEC MS-012 variation AC.



4220204/A 02/2017

NOTES:

1. All linear dimensions are in millimeters. Any dimensions in parenthesis are for reference only. Dimensioning and tolerancing per ASME Y14.5M.
2. This drawing is subject to change without notice.
3. This dimension does not include mold flash, protrusions, or gate burrs. Mold flash, protrusions, or gate burrs shall not exceed 0.15 mm per side.
4. This dimension does not include interlead flash. Interlead flash shall not exceed 0.25 mm per side.
5. Reference JEDEC registration MO-153.

EXAMPLE BOARD LAYOUT

PW0016A

TSSOP - 1.2 mm max height

SMALL OUTLINE PACKAGE



LAND PATTERN EXAMPLE
EXPOSED METAL SHOWN
SCALE: 10X



SOLDER MASK DETAILS

4220204/A 02/2017

NOTES: (continued)

- 6. Publication IPC-7351 may have alternate designs.
- 7. Solder mask tolerances between and around signal pads can vary based on board fabrication site.

EXAMPLE STENCIL DESIGN

PW0016A

TSSOP - 1.2 mm max height

SMALL OUTLINE PACKAGE



SOLDER PASTE EXAMPLE
BASED ON 0.125 mm THICK STENCIL
SCALE: 10X

4220204/A 02/2017

NOTES: (continued)

8. Laser cutting apertures with trapezoidal walls and rounded corners may offer better paste release. IPC-7525 may have alternate design recommendations.
9. Board assembly site may have different recommendations for stencil design.

重要なお知らせと免責事項

TI は、技術データと信頼性データ(データシートを含みます)、設計リソース(リファレンス・デザインを含みます)、アプリケーションや設計に関する各種アドバイス、Web ツール、安全性情報、その他のリソースを、欠陥が存在する可能性のある「現状のまま」提供しており、商品性および特定目的に対する適合性の黙示保証、第三者の知的財産権の非侵害保証を含むいかなる保証も、明示的または黙示的にかかわらず拒否します。

これらのリソースは、TI 製品を使用する設計の経験を積んだ開発者への提供を意図したものです。(1) お客様のアプリケーションに適した TI 製品の選定、(2) お客様のアプリケーションの設計、検証、試験、(3) お客様のアプリケーションに該当する各種規格や、その他のあらゆる安全性、セキュリティ、規制、または他の要件への確実な適合に関する責任を、お客様のみが単独で負うものとし、

上記の各種リソースは、予告なく変更される可能性があります。これらのリソースは、リソースで説明されている TI 製品を使用するアプリケーションの開発の目的でのみ、TI はその使用をお客様に許諾します。これらのリソースに関して、他の目的で複製することや掲載することは禁止されています。TI や第三者の知的財産権のライセンスが付与されている訳ではありません。お客様は、これらのリソースを自身で使用した結果発生するあらゆる申し立て、損害、費用、損失、責任について、TI およびその代理人を完全に補償するものとし、TI は一切の責任を拒否します。

TI の製品は、[TI の販売条件](#)、または [ti.com](#) やかかる TI 製品の関連資料などのいずれかを通じて提供する適用可能な条項の下で提供されています。TI がこれらのリソースを提供することは、適用される TI の保証または他の保証の放棄の拡大や変更を意味するものではありません。

お客様がいかなる追加条項または代替条項を提案した場合でも、TI はそれらに異議を唱え、拒否します。

郵送先住所 : Texas Instruments, Post Office Box 655303, Dallas, Texas 75265
Copyright © 2024, Texas Instruments Incorporated