

Getting the most out of your instrumentation amplifier design

By Thomas Kugelstadt (Email: tk@ti.com)
Senior Systems Engineer, Industrial Systems

Many industrial and medical applications use instrumentation amplifiers (INAs) to condition small signals in the presence of large common-mode voltages and DC potentials. Standard INAs using a unity-gain difference amplifier in the output stage, however, can limit the input common-mode range significantly. Thus, common-mode signals induced by adjacent equipment, as well as large differential DC potentials from differently located signal sources, can increase the input voltage of the INA, causing its input stage to saturate. Saturation causes the INA output voltage, although of wrong value, to appear normal to the following processing circuitry. This could lead to disastrous effects with unpredictable consequences.

This article reviews some principles of the classic three-op-amp INA and provides design hints that extend the input common-mode range to avoid saturation while preserving overall gain at maximum value. The article also discusses the removal of large differential DC voltages through active filtering, avoiding passive RC filters at the INA input that otherwise would lower its common-mode rejection ratio (CMRR).

INA principles

Figure 1 shows the block diagram of the classic three-op-amp INA. The inputs, V_{IN+} and V_{IN-} , are defined through the input polarities of the difference amplifier, A3.

By definition, the INA's input signals are subdivided into a common-mode voltage, V_{CM} , and a differential voltage, V_D . While V_{CM} , the voltage common to both inputs, is defined as the average of the sum of V_{IN+} and V_{IN-} , V_D represents the net difference between the two.

$$V_{CM} = \frac{V_{IN+} + V_{IN-}}{2} \quad \text{and} \quad V_D = V_{IN+} - V_{IN-}. \quad (1)$$

Solving both equations for V_{IN+} or V_{IN-} and equating the received terms results in a new set of equations, which, when solved for either input voltage, yields

$$V_{IN+} = V_{CM} + \frac{V_D}{2} \quad \text{and} \quad V_{IN-} = V_{CM} - \frac{V_D}{2}. \quad (2)$$

Figure 1. Classic three-op-amp INA and its voltage nodes

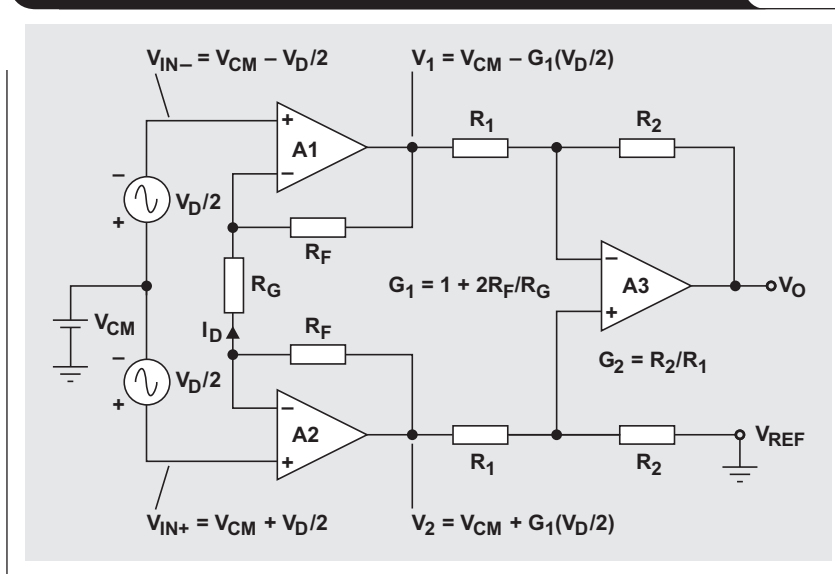

In the nonsaturated mode, the op amp action of A1 and A2 applies the differential voltage V_D across the gain resistor, R_G , generating the input current, I_D :

$$I_D = \frac{V_{IN+} - V_{IN-}}{R_G} = \frac{V_D}{R_G}. \quad (3)$$

The output voltages of A1 and A2 are therefore

$$V_1 = V_{CM} - \frac{V_D}{2} - I_D R_F \quad \text{and} \quad V_2 = V_{CM} + \frac{V_D}{2} + I_D R_F.$$

Replacing current I_D with Equation 3 yields

$$V_1 = V_{CM} - \frac{V_D}{2} G_1 \quad \text{and} \quad V_2 = V_{CM} + \frac{V_D}{2} G_1, \quad (4)$$

where $G_1 = 1 + 2 \frac{R_F}{R_G}$.

Equation 4 shows that only the differential component, $V_D/2$, is amplified by the input gain, G_1 , while the common-mode voltage, V_{CM} , passes the input stage with unity gain.

The difference amplifier, A3, subtracts V_1 from V_2 and amplifies the difference with the gain G_2 :

$$V_O = (V_2 - V_1) G_2, \quad \text{where} \quad G_2 = \frac{R_2}{R_1}. \quad (5)$$

Inserting Equation 4 into Equation 5 and solving for V_O/V_D provides the transfer function of the INA:

$$\frac{V_O}{V_D} = G_1 G_2 = G_{TOT} \tag{6}$$

Extending the input common-mode voltage range

Note that V_1 and V_2 in Equation 4 do not represent absolute voltages. Because V_{CM} and V_D can change their polarities, the maximum voltage either output can assume before reaching saturation is

$$\pm |V_{1,2}| = \pm \left(|V_{CM}| + \left| \frac{V_D}{2} \right| \right) \leq \pm |V_{SAT}|$$

For clarification, the following description simply ignores signal polarities, and the variables refer only to magnitude values. Assuming that $V_{1,2}$ and $V_D/2$ are constant, the only way to increase the input common-mode voltage from V_{CM} to V_{CM}' is to reduce the input gain from G_1 to G_1' so that

$$V_{1,2} = \text{constant} = V_{CM} + \frac{V_D}{2} G_1 = V_{CM}' + \frac{V_D}{2} G_1'$$

Solving for V_{CM}' yields

$$V_{CM}' = V_{CM} + \frac{V_D}{2} (G_1 - G_1')$$

Reducing G_1 reduces the range of the amplified differential component, $G_1'(V_D/2)$, thus providing an expansion range for V_{CM} . Standard INAs, using unity-gain difference amplifiers, have $R_2 = R_1$ and $G_2 = 1$.

The total INA gain is then placed into the input stage, making $G_1 = G_{TOT}$. Equation 6 shows that reducing G_1 from G_{TOT} to G_1' , while preserving G_{TOT} , requires an increase in difference amplifier gain from $G_2 = 1$ to $G_2' = G_{TOT}/G_1'$.

Replacing G_1 with G_{TOT} and G_1' with G_{TOT}/G_2' results in the extended common-mode range:

$$\begin{aligned} V_{CM}' &= V_{CM} + \frac{V_D}{2} G_{TOT} \left(1 - \frac{1}{G_2'} \right) \\ &= V_{CM} + \frac{V_D}{2} G_1' (G_2' - 1). \end{aligned} \tag{7}$$

This improved common-mode range at the amplifier output is now passed on 1:1 to the input. Applying gain to the difference amplifier requires access to the feedback resistor of A3 in Figure 2. A common solution uses a stand-alone difference amplifier, which provides access to the feedback resistor via a V_{SENSE} pin. The input stage is then realized by a dual low-noise amplifier, with external resistors R_F and R_G being used to set the input gain.

To raise the gain of a unity-gain amplifier, external resistors can be switched in series to R_2 . However, the internal resistor values must be measured, as they can deviate by $\pm 30\%$ from their nominal values given in the datasheet. This approach works well for moderate gain. For large gain, however, the external resistors can reach prohibitive values, increasing noise to an undesirable level. A buffered voltage divider in the feedback path of A3 is then required.

Resistors R_3 and R_4 allow a wide range of gain settings with moderate resistor values. Voltage follower A4 provides low output impedance, which preserves the high CMRR of the difference amplifier.

Removing large differential DC potentials

The signal conditioning in analog front ends of medical equipment, such as electrocardiographs (ECGs), presents the additional design challenge of detecting small AC signals in the presence of large differential DC potentials.

Figure 2. Increasing difference amplifier gain via R_{EXT} or buffered voltage divider

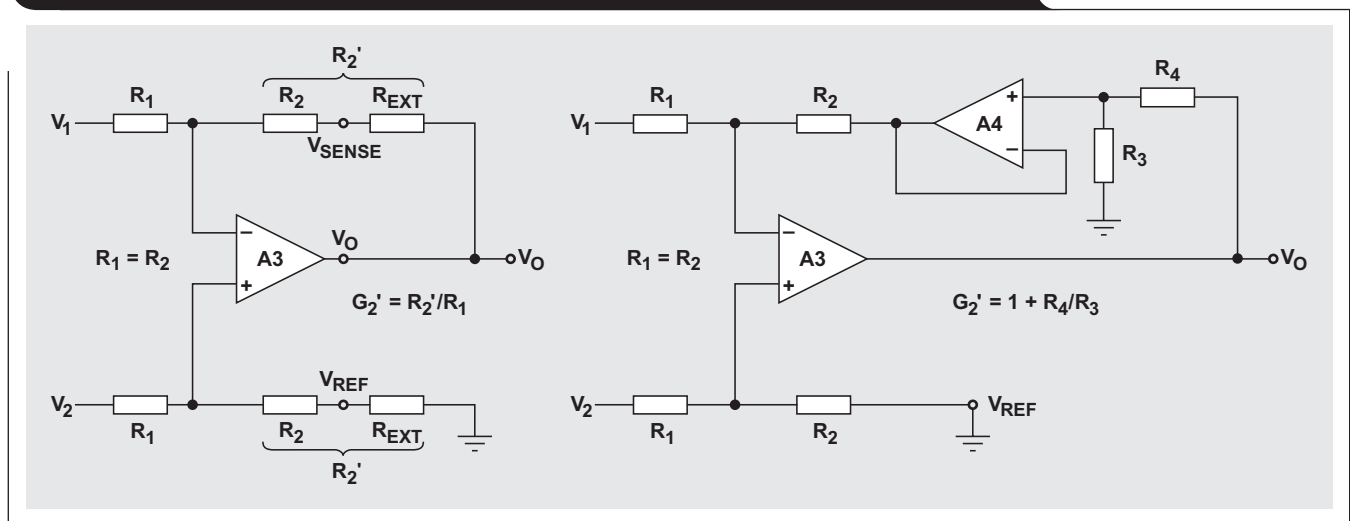

Signal composition

Contraction of the heart wall spreads electrical currents from the heart throughout the body. The currents create different potentials at different parts of the body, which are sensed by electrodes on the skin surface via biological transducers made of metals and salt.

A typical electric potential is a 0.5- to 1.5-mV AC signal with a bandwidth of 0.05 to 100 Hz and sometimes up to 1 kHz. This signal is superimposed by a large electrode DC offset potential of ± 500 mV and a large common-mode voltage of up to 1.5 V. The common-mode voltage comprises two parts: 50- to 60-Hz interference and DC electrode offset potential.

To determine the input signal of the INA in the ECG front end, the electrode attached to a patient's right arm has a DC offset of 450 mV and an AC signal of 0.5 mV_{PP}, while the one on the left arm has a 50-mV_{PP} offset and 1.5-mV_{PP} AC. The differential input is therefore

$$\begin{aligned} V_D &= V_{D_DC} + V_{D_AC} \\ &= (V_{DC_R} - V_{DC_L}) + (V_{AC(PP)_R} - V_{AC(PP)_L}) \\ &= 400 \text{ mV} + 1 \text{ mV}. \end{aligned}$$

Thus, the differential DC is 400 times larger than the AC signal of interest and, if untreated, will receive amplification through the entire INA, causing its amplifiers to saturate.

At the same time, to convert the 1-mV AC into a representative signal that is of use to a following signal processing system, a total gain of 1000 or more is required.

The solution to this problem is performed in three steps:

- (1) Limit the input gain, G_1 , to avoid saturation of A1 and A2;
- (2) implement low-pass filtering in the output stage to remove the differential DC, V_{D_DC} ; and
- (3) apply high gain in the output stage, boosting the AC signal of interest, V_{D_AC} .

To determine G_1 , the INA is assumed to operate from a typical ± 5 -V supply. For simplification, A1 to A3 have rail-to-rail inputs and outputs, and the common-mode potential is at a maximum of $V_{CM} = 1.5$ V.

Neglecting the small AC component of V_D , rewriting Equation 4 for G_1 gives a maximum input gain of

$$G_1 = 2 \left(\frac{V_{2_SAT} - V_{CM}}{V_{D_DC}} \right) = 2 \left(\frac{5 \text{ V} - 1.5 \text{ V}}{400 \text{ mV}} \right) = 17.5.$$

For convenience, we choose a conservative value of $G_1 = 10$; thus, the differential input signal of A3 consists of a 4-V DC component and a 10-mV AC component. To remove the DC part, an active low-pass filter is implemented, providing negative feedback from the output to the noninverting input of A3. At the same time, output gain, G_2 , is increased by the buffered voltage divider, R_3, R_4 .

Figure 3. Difference amplifier with low-pass filter and gain stage

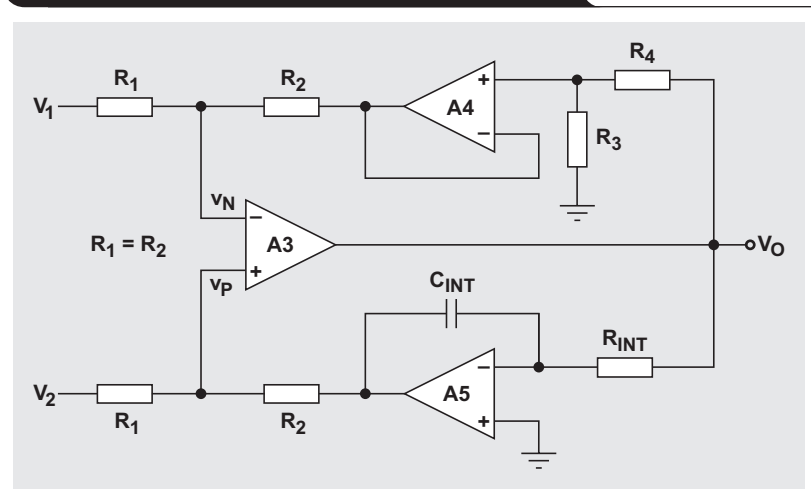

To determine G_2 , we calculate the total gain for maximum dynamic output range,

$$G_{TOT} = \frac{V_{SAT}}{V_{D_AC}} = \frac{5 \text{ V}}{1 \text{ mV}} = 5000,$$

and divide it by the applied input gain,

$$G_2 = \frac{G_{TOT}}{G_1} = \frac{5000}{10} = 500.$$

With the low-pass filter in the feedback loop of A3, the transfer function of the difference amplifier assumes high-pass characteristics. One would now assume that the filter's -3 -dB frequency occurs at

$$f_0 = \frac{1}{2\pi R_{INT} C_{INT}}.$$

However, establishing the transfer function reveals that f_0 has been increased by the gain factor G_2 to $f_0' = f_0 G_2$.

Mathematical proof:

By op amp action, the input terminals of A3 (Figure 3) have identical potentials: $v_N = v_P$. Thus, for $R_1 = R_2$:

$$v_N = \frac{V_1}{2} + \frac{V_O}{2G_2} \quad \text{and} \quad v_P = \frac{V_2}{2} - \left(\frac{V_O}{2} \right) \left(\frac{1}{jf/f_0} \right),$$

$$\text{where } G_2 = 1 + \frac{R_4}{R_3} \quad \text{and} \quad f_0 = \frac{1}{j\omega R_{INT} C_{INT}}.$$

Equating both expressions and solving for $V_O/(V_2 - V_1)$ yields the transfer function of the output stage:

$$\frac{V_O}{V_2 - V_1} = G_2 \left(\frac{j \frac{f}{f_0 G_2}}{1 + j \frac{f}{f_0 G_2}} \right) = G_2 \left(\frac{j \frac{f}{f_0'}}{1 + j \frac{f}{f_0'}} \right).$$

Figure 4. INA128 with OPA2132 providing low-pass filter and external gain stage

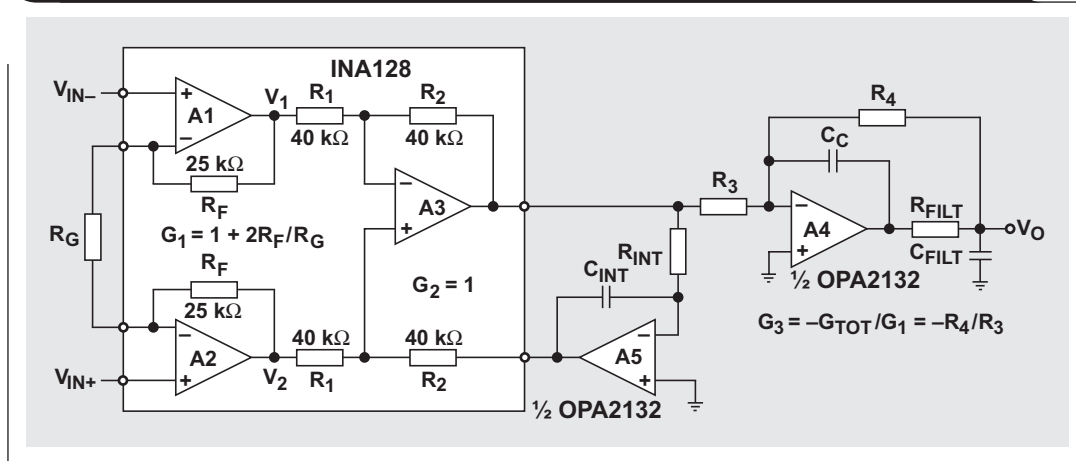

To return to the specified f_0 of 0.05 Hz requires the increase of the time constant by the factor G_2 , thus quickly leading to prohibitive values for R_{INT} and C_{INT} .

There are two alternatives to design around this problem. Either (1) change the gain settings of G_1 , G_2 , and G_{TOT} until moderate values for R_{INT} and C_{INT} can be found, or (2) make $G_2 = 1$ and perform the final signal boost via a separate gain stage (Figure 4).

The latter approach, which is the easier one, provides the following benefits:

- Standard INAs with unity-gain output stages, such as INA128 or INA118, can be used. Both devices allow for input gains from 1 to 10000, providing a maximum non-linearity of 0.002%.

- Gain-booster A4 and integrator A5 can be designed with the dual low-noise amplifier OPA2132 with an input-referred noise of 8 nV/√Hz.
- The adjustment of G_1 is independent from G_2 and f_0 , allowing the input gain to be set for maximum input common-mode range.
- The RC values defining the integrator time constant now reflect the real lower-bandwidth limit, f_0 .
- The final gain stage A4 allows independent adjustment of any desired gain value and performs low-pass filtering of high-frequency noise.

Single-supply applications

Portable ECG equipment requiring single-supply operation can use the high-precision analog front end in Figure 5.

Figure 5. High-precision analog front end of a portable ECG application

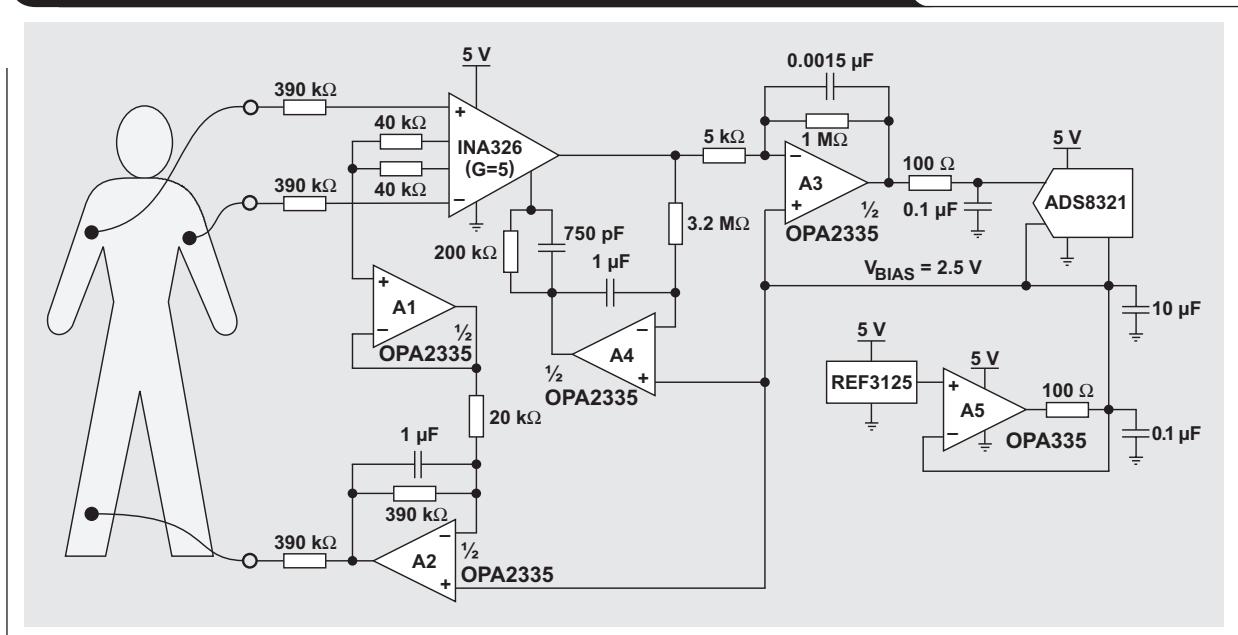

Both types of amplifiers, the instrumentation amplifier INA326 and the dual precision amplifier OPA2335, operate from a single 5-V supply and apply autozeroing techniques, keeping the initial offset and offset drift over temperature and time near zero.

The input gain of the INA326 is set to 5 via $G_1 = 2R_2/R_G = 2(200 \text{ k}\Omega/80 \text{ k}\Omega)$. The 750-pF capacitor parallel to R_2 cancels resistor noise. The 3-dB frequency of the integrator A4 is set to 0.05 Hz, while the output stage around A3 provides a gain of $G_2 = 1 \text{ M}\Omega/5 \text{ k}\Omega = 200$. The precision voltage reference, REF3125, provides low-noise biasing of the 2.5-V bias voltage to the amplifiers and the 16-bit, 100-kSPS, SAR-ADC ADS8321.

To further reject 50/60-Hz noise, the input common-mode voltage is fed back via the amplifiers A1 and A2 to the right leg of the patient. This approach requires only a few microamps of current to significantly improve the common-mode rejection and to ensure compliance with the UL544 standard.

Summary

This article has described extension of the input common-mode range and filtering of large DC potentials in high-gain signal conditioners with three-op-amp INAs.

Further application information, in particular about high-precision, single-supply INAs, is available at www.ti.com, keyword “instrumentation amplifier.”

Related Web sites

amplifier.ti.com

www.ti.com/sc/device/partnumber

Replace *partnumber* with ADS8321, INA118, INA128, INA326, OPA335, OPA2132, OPA2227, OPA2335, or REF3125

IMPORTANT NOTICE

Texas Instruments Incorporated and its subsidiaries (TI) reserve the right to make corrections, modifications, enhancements, improvements, and other changes to its products and services at any time and to discontinue any product or service without notice. Customers should obtain the latest relevant information before placing orders and should verify that such information is current and complete. All products are sold subject to TI's terms and conditions of sale supplied at the time of order acknowledgment.

TI warrants performance of its hardware products to the specifications applicable at the time of sale in accordance with TI's standard warranty. Testing and other quality control techniques are used to the extent TI deems necessary to support this warranty. Except where mandated by government requirements, testing of all parameters of each product is not necessarily performed.

TI assumes no liability for applications assistance or customer product design. Customers are responsible for their products and applications using TI components. To minimize the risks associated with customer products and applications, customers should provide adequate design and operating safeguards.

TI does not warrant or represent that any license, either express or implied, is granted under any TI patent right, copyright, mask work right, or other TI intellectual property right relating to any combination, machine, or process in which TI products or services are used. Information published by TI regarding third-party products or services does not constitute a license from TI to use such products or services or a warranty or endorsement thereof. Use of such information may require a license from a third party under the patents or other intellectual property of the third party, or a license from TI under the patents or other intellectual property of TI.

Reproduction of information in TI data books or data sheets is permissible only if reproduction is without alteration and is accompanied by all associated warranties, conditions, limitations, and notices. Reproduction of this information with alteration is an unfair and deceptive business practice. TI is not responsible or liable for such altered documentation.

Resale of TI products or services with statements different from or beyond the parameters stated by TI for that product or service voids all express and any implied warranties for the associated TI product or service and is an unfair and deceptive business practice. TI is not responsible or liable for any such statements.

Following are URLs where you can obtain information on other Texas Instruments products and application solutions:

Products

Amplifiers	amplifier.ti.com
Data Converters	dataconverter.ti.com
DSP	dsp.ti.com
Interface	interface.ti.com
Logic	logic.ti.com
Power Mgmt	power.ti.com
Microcontrollers	microcontroller.ti.com

Applications

Audio	www.ti.com/audio
Automotive	www.ti.com/automotive
Broadband	www.ti.com/broadband
Digital control	www.ti.com/digitalcontrol
Military	www.ti.com/military
Optical Networking	www.ti.com/opticalnetwork
Security	www.ti.com/security
Telephony	www.ti.com/telephony
Video & Imaging	www.ti.com/video
Wireless	www.ti.com/wireless

TI Worldwide Technical Support

Internet

TI Semiconductor Product Information Center Home Page
support.ti.com

TI Semiconductor KnowledgeBase Home Page
support.ti.com/sc/knowledgebase

Product Information Centers

Americas

Phone	+1(972) 644-5580	Fax	+1(972) 927-6377
Internet/Email	support.ti.com/sc/pic/americas.htm		

Europe, Middle East, and Africa

Phone			
Belgium (English)	+32 (0) 27 45 54 32	Netherlands (English)	+31 (0) 546 87 95 45
Finland (English)	+358 (0) 9 25173948	Russia	+7 (0) 95 363 4824
France	+33 (0) 1 30 70 11 64	Spain	+34 902 35 40 28
Germany	+49 (0) 8161 80 33 11	Sweden (English)	+46 (0) 8587 555 22
Israel (English)	1800 949 0107	United Kingdom	+44 (0) 1604 66 33 99
Italy	800 79 11 37		
Fax	+49 (0) 8161 80 2045		
Internet	support.ti.com/sc/pic/euro.htm		

Japan

Fax			
International	+81-3-3344-5317	Domestic	0120-81-0036
Internet/Email			
International	support.ti.com/sc/pic/japan.htm		
Domestic	www.tij.co.jp/pic		

Asia

Phone			
International	+886-2-23786800		
Domestic	Toll-Free Number		
Australia	1-800-999-084	Malaysia	1-800-80-3973
China	800-820-8682	New Zealand	0800-446-934
Hong Kong	800-96-5941	Philippines	1-800-765-7404
India	+91-80-51381665 (Toll)	Singapore	800-886-1028
Indonesia	001-803-8861-1006	Taiwan	0800-006800
Korea	080-551-2804	Thailand	001-800-886-0010
Fax	886-2-2378-6808	Email	tiasia@ti.com
Internet	support.ti.com/sc/pic/asia.htm		
			ti-china@ti.com

C091905

Safe Harbor Statement: This publication may contain forward-looking statements that involve a number of risks and uncertainties. These "forward-looking statements" are intended to qualify for the safe harbor from liability established by the Private Securities Litigation Reform Act of 1995. These forward-looking statements generally can be identified by phrases such as "TI or its management believes," "expects," "anticipates," "foresees," "forecasts," "estimates" or other words or phrases of similar import. Similarly, such statements herein that describe the company's products, business strategy, outlook, objectives, plans, intentions or goals also are forward-looking statements. All such forward-looking statements are subject to certain risks and uncertainties that could cause actual results to differ materially from those in forward-looking statements. Please refer to TI's most recent Form 10-K for more information on the risks and uncertainties that could materially affect future results of operations. We disclaim any intention or obligation to update any forward-looking statements as a result of developments occurring after the date of this publication.

Trademarks: All trademarks are the property of their respective owners.

Mailing Address: Texas Instruments
Post Office Box 655303
Dallas, Texas 75265

© 2005 Texas Instruments Incorporated