

# TPS54623 4.5V~17V入力、6A同期整流降圧型SWIFT™コンバータ、軽負荷効率およびHiccup過電流保護搭載

## 1 特長

- 26 mΩ、19 mΩ MOSFETを内蔵
- 分割電源レール: PVIN上で1.6V~17V
- 200kHz~1.6MHzのスイッチング周波数
- パルス・スキップによる軽負荷時の高効率
- 外部クロックに同期
- 温度範囲全体にわたって0.6V ±1%の基準電圧
- シャットダウン時に2μAの低静止電流
- プリバイアスされた出力への単調スタートアップ
- 動作時の接合部温度範囲: -40°C~150°C
- 可変スロー・スタートとパワー・シーケンシング
- 低電圧および過電圧用のパワーグッド出力モニタ
- 調整可能な入力低電圧誤動作防止
- WEBENCH® Power Designerにより、TPS54623を使用するカスタム設計を作成

## 2 アプリケーション

- 高密度分散電源システム
- 高性能ポイント・オブ・ロード(POL)レギュレーション
- ブロードバンド、ネットワーク、光通信インフラ

概略回路図

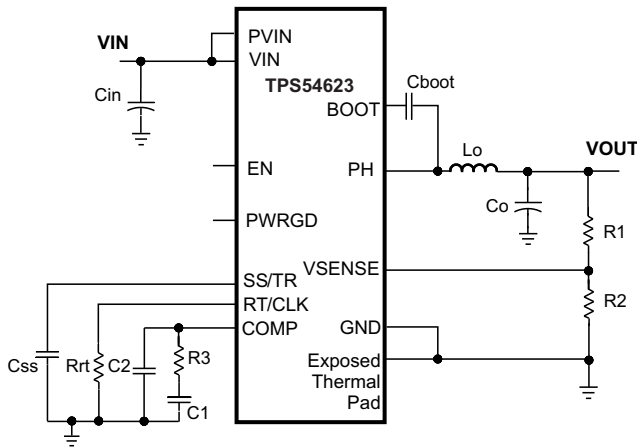

Copyright © 2016, Texas Instruments Incorporated

## 3 概要

TPS54623は、放熱特性の優れたVQFNパッケージで供給され、完全な機能を備えた17V、6Aの同期整流降圧型コンバータで、高効率とハイサイドおよびローサイドMOSFET内蔵により、小型の設計に最適化されています。電流モード制御による部品数の削減と、高いスイッチング周波数によるインダクタの占有面積削減により、さらに容積を節約できます。

出力電圧のスタートアップ・ランプはSS/TRピンにより制御され、スタンドアロン電源としても、トラッキング状況でも動作できます。イネーブルおよびオープン・ドレインのパワーグッド・ピンを適切に構成することにより、電源シーケンシングも可能です。

ハイサイドFETにサイクル単位の電流制限を適用することで、過負荷状況からデバイスを保護し、ローサイドのソース電流制限により電流暴走を防止して、さらに保護が強化されています。また、ローサイドのシンク電流制限によりローサイドMOSFETをオフにすることで、過度な逆方向電流を防止します。あらかじめ設定した時間以上にわたって過電流状態が続いた場合は、ヒカップ保護が作動します。過熱ヒカップ保護により、ダイの温度が過熱シャットダウン温度を超えるとデバイスがディセーブルされ、設定済みの過熱シャットダウン・ヒカップ時間が経過するとイネーブルに戻ります。TPS54623は、高負荷条件では連続電流モード(CCM)で動作し、軽負荷ではパルスをスキップすることで効率を高めます。

製品情報<sup>(1)</sup>

型番	パッケージ	本体サイズ(公称)
TPS54623	VQFN (14)	3.50mm×3.50mm

(1) 利用可能なすべてのパッケージについては、このデータシートの末尾にある注文情報を参照してください。

効率と負荷電流との関係

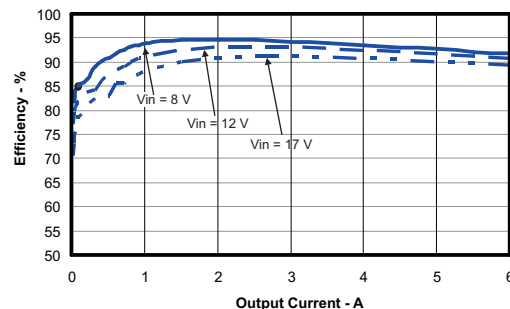

## 目次

1	特長 .....	1	8	Application and Implementation .....	24
2	アプリケーション .....	1	8.1	Application Information .....	24
3	概要 .....	1	8.2	Typical Application .....	24
4	改訂履歴 .....	2	9	Power Supply Recommendations .....	32
5	Pin Configuration and Functions .....	3	10	Layout .....	32
6	Specifications .....	4	10.1	Layout Guidelines .....	32
6.1	Absolute Maximum Ratings .....	4	10.2	Layout Examples .....	33
6.2	ESD Ratings .....	4	11	デバイスおよびドキュメントのサポート .....	35
6.3	Recommended Operating Conditions .....	4	11.1	デバイス・サポート .....	35
6.4	Thermal Information .....	5	11.2	ドキュメントのサポート .....	35
6.5	Electrical Characteristics .....	5	11.3	ドキュメントの更新通知を受け取る方法 .....	35
6.6	Typical Characteristics .....	7	11.4	コミュニティ・リソース .....	35
7	Detailed Description .....	10	11.5	商標 .....	35
7.1	Overview .....	10	11.6	静電気放電に関する注意事項 .....	36
7.2	Functional Block Diagram .....	11	11.7	Glossary .....	36
7.3	Feature Description .....	11	12	メカニカル、パッケージ、および注文情報 .....	36
7.4	Device Functional Modes .....	21			

## 4 改訂履歴

### Revision B (January 2017) から Revision C に変更

Page

•	TI Design用に上端のナビ・アイコンを追加 .....	1
•	p.1、および「アプリケーションと実装」と「デバイスおよびドキュメントのサポート」セクションにWEBENCHへのリンク追加 .....	1
•	細部の編集 .....	1
•	Changed $R_{\theta JA}$ value from "47.2" to "40.1" .....	5
•	Changed $R_{\theta JTop}$ value from "64.8" to "34.4" .....	5
•	$R_{\theta JB}$ value from "14.4" to "11.4" .....	5
•	Changed $\psi_{JB}$ value from "14.7" to "11.4" .....	5
•	Changed $R_{\theta JBot}$ value from "3.2" to "1.8" .....	5
•	Added new paragraph to end of <a href="#">Sequencing (SS/TR)</a> .....	16

### Revision A (March 2016) から Revision B に変更

Page

•	Changed Error amplifier dc gain test conditions, VSENSE from 0.8 V to 0.6 V .....	5
•	Changed the voltage reference (Vref) from 0.8 V to 0.6 V in <a href="#">Slow Start (SS/TR)</a> description. ....	14
•	Changed "...internal voltage reference of 0.8 V. Above 0.8 V.." to "...internal voltage reference of 0.6 V. Above 0.6 V..." in <a href="#">Minimum Output Voltage</a> description. ....	28

### 2011年9月発行のものから更新

Page

•	「ESD定格」表、「機能説明」セクション、「デバイスの機能モード」セクション、「アプリケーションと実装」セクション、「電源に関する推奨事項」セクション、「レイアウト」セクション、「デバイスおよびドキュメントのサポート」セクション、「メカニカル、パッケージ、および注文情報」セクションを追加 .....	1
•	Deleted Ordering Information table .....	3

## 5 Pin Configuration and Functions

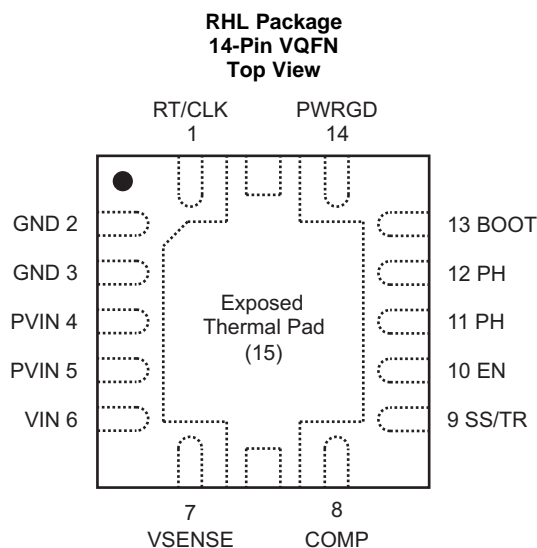

### Pin Functions

PIN		I/O	DESCRIPTION
NAME	NO		
BOOT	13	O	A bootstrap cap is required between BOOT and PH. The voltage on this cap carries the gate drive voltage for the high-side MOSFET.
COMP	8	I/O	Error amplifier output, and input to the output switch current comparator. Connect frequency compensation to this pin.
EN	10	I	Enable pin. Float to enable. Adjust the input undervoltage lockout with two resistors.
GND	2	—	Return for control circuitry and low-side power MOSFET.
GND	3	—	Return for control circuitry and low-side power MOSFET.
PH	11	O	The switch node.
PH	12	O	The switch node.
PVIN	4	I	Power input. Supplies the power switches of the power converter.
PVIN	5	I	Power input. Supplies the power switches of the power converter.
PWRGD	14	O	Power Good fault pin. Asserts low if output voltage is low due to thermal shutdown, dropout, over-voltage, EN shutdown or during slow start.
RT/CLK	1	I	Automatically selects between RT mode and CLK mode. An external timing resistor adjusts the switching frequency of the device; In CLK mode, the device synchronizes to an external clock.
SS/TR	9	I	Slow-start and tracking. An external capacitor connected to this pin sets the internal voltage reference rise time. The voltage on this pin overrides the internal reference. It can be used for tracking and sequencing.
VIN	6	I	Supplies the control circuitry of the power converter.
VSENSE	7	I	Inverting input of the gm error amplifier.
Exposed Thermal Pad	15	—	Thermal pad of the package and signal ground and it must be soldered down for proper operation.

## 6 Specifications

### 6.1 Absolute Maximum Ratings

 over operating free-air temperature range (unless otherwise noted)<sup>(1)</sup>

		MIN	MAX	UNIT
Input voltage	VIN	-0.3	20	V
	PVIN	-0.3	20	
	EN	-0.3	6	
	BOOT	-0.3	27	
	VSENSE	-0.3	3	
	COMP	-0.3	3	
	PWRGD	-0.3	6	
	SS/TR	-0.3	3	
	RT/CLK	-0.3	6	
Output voltage	BOOT-PH	0	7.5	V
	PH	-1	20	
	PH (10-ns transient)	-3	20	
Vdiff (GND to exposed thermal pad)		-0.2	0.2	V
Source current	RT/CLK	±100		µA
	PH	Current limit		A
Sink current	PH	Current limit		A
	PVIN	Current limit		A
	COMP	±200		µA
	PWRGD	-0.1	5	mA
Operating junction temperature, T <sub>J</sub>		-40	150	°C
Storage temperature, T <sub>stg</sub>		-65	150	°C

(1) Stresses beyond those listed under *Absolute Maximum Ratings* may cause permanent damage to the device. These are stress ratings only, which do not imply functional operation of the device at these or any other conditions beyond those indicated under *Recommended Operating Conditions*. Exposure to absolute-maximum-rated conditions for extended periods may affect device reliability.

### 6.2 ESD Ratings

		VALUE	UNIT
V <sub>(ESD)</sub> Electrostatic discharge	Human-body model (HBM), per ANSI/ESDA/JEDEC JS-001 <sup>(1)</sup>	±2000	V
	Charged-device model (CDM), per JEDEC specification JESD22-C101 <sup>(2)</sup>	±500	

(1) JEDEC document JEP155 states that 500-V HBM allows safe manufacturing with a standard ESD control process.

(2) JEDEC document JEP157 states that 250-V CDM allows safe manufacturing with a standard ESD control process.

### 6.3 Recommended Operating Conditions

over operating free-air temperature range (unless otherwise noted)

		MIN	NOM	MAX	UNIT
V <sub>VIN</sub>	Input voltage	4.5		17	V
V <sub>PVIN</sub>	Input voltage	1.7		17	V
I <sub>OUT</sub>	Output current	0		6	A
T <sub>J</sub>	Operating junction temperature	-40		150	°C

## 6.4 Thermal Information

THERMAL METRIC <sup>(1)(2)</sup>		TPS54623	UNIT	
		RHL (VQFN)		
		14 PINS		
R <sub>θJA</sub>	Junction-to-ambient	Thermal resistance	40.1	°C/W
		Test board <sup>(3)</sup>	32	
R <sub>θJC(top)</sub>	Junction-to-case (top) thermal resistance		34.4	°C/W
R <sub>θJB</sub>	Junction-to-board thermal resistance		11.4	°C/W
ψ <sub>JT</sub>	Junction-to-top characterization parameter		0.5	°C/W
ψ <sub>JB</sub>	Junction-to-board characterization parameter		11.4	°C/W
R <sub>θJC(bot)</sub>	Junction-to-case (bottom) thermal resistance		1.8	°C/W

- (1) For more information about traditional and new thermal metrics, see the [Semiconductor and IC Package Thermal Metrics](#) application report.
- (2) Power rating at a specific ambient temperature T<sub>A</sub> should be determined with a junction temperature of 150°C. This is the point where distortion starts to substantially increase. Thermal management of the PCB should strive to keep the junction temperature at or below 150°C for best performance and long-term reliability. See power dissipation estimate in application section of this data sheet for more information.
- (3) Test board conditions:
  - (a) 2.5 inches x 2.5 inches, 4 layers, thickness: 0.062 inch
  - (b) 2 oz. copper traces located on the top of the PCB
  - (c) 2 oz. copper ground planes on the 2 internal layers and bottom layer
  - (d) 4 0.010 inch thermal vias located under the device package

## 6.5 Electrical Characteristics

T<sub>J</sub> = –40°C to 150°C, V<sub>IN</sub> = 4.5 V to 17 V, P<sub>VIN</sub> = 1.6 V to 17 V (unless otherwise noted)

PARAMETER	TEST CONDITIONS	MIN	TYP	MAX	UNIT
<b>SUPPLY VOLTAGE (VIN AND PVIN PINS)</b>					
PVIN operating input voltage		1.6		17	V
VIN operating input voltage		4.5		17	V
VIN internal UVLO threshold	VIN rising		4.0	4.5	V
VIN internal UVLO hysteresis			150		mV
VIN shutdown supply Current	EN = 0 V		2	5	μA
VIN operating – non switching supply current	VSENSE = 810 mV		250	500	μA
<b>ENABLE AND UVLO (EN PIN)</b>					
Enable threshold	Rising		1.21	1.26	V
Enable threshold	Falling	1.10	1.17		V
Input current	EN = 1.1 V		1.15		μA
Hysteresis current	EN = 1.3 V		3.3		μA
<b>VOLTAGE REFERENCE</b>					
Voltage reference	0 A ≤ I <sub>OUT</sub> ≤ 6 A	0.594	0.6	0.606	V
<b>MOSFET</b>					
High-side switch resistance	BOOT-PH = 3 V		32	60	mΩ
High-side switch resistance <sup>(1)</sup>	BOOT-PH = 6 V		26	40	mΩ
Low-side switch resistance <sup>(1)</sup>	VIN = 12 V		19	30	mΩ
<b>ERROR AMPLIFIER</b>					
Error amplifier Transconductance (gm)	–2 μA < I <sub>COMP</sub> < 2 μA, V <sub>(COMP)</sub> = 1 V		1300		μMhos
Error amplifier dc gain	VSENSE = 0.6 V	1000	3100		V/V
Error amplifier source/sink	V <sub>(COMP)</sub> = 1 V, 100 mV input overdrive		±110		μA
Start switching peak current threshold			1		A
COMP to I <sub>switch</sub> gm			16		A/V

- (1) Measured at pins

**Electrical Characteristics (continued)**
 $T_J = -40^{\circ}\text{C}$  to  $150^{\circ}\text{C}$ ,  $V_{IN} = 4.5\text{ V}$  to  $17\text{ V}$ ,  $PV_{IN} = 1.6\text{ V}$  to  $17\text{ V}$  (unless otherwise noted)

PARAMETER	TEST CONDITIONS	MIN	TYP	MAX	UNIT
<b>CURRENT LIMIT</b>					
High-side switch current limit threshold		8	11	14	A
Low-side switch sourcing current limit		6.5	10	15	A
Low-side switch sinking current limit			200	600	mA
Hiccup wait time			512		Cycles
Hiccup time before re-start			16384		Cycles
<b>THERMAL SHUTDOWN</b>					
Thermal shutdown		160	175		$^{\circ}\text{C}$
Thermal shutdown hysteresis			10		$^{\circ}\text{C}$
Thermal shutdown hiccup time			16384		Cycles
<b>TIMING RESISTOR AND EXTERNAL CLOCK (RT/CLK PIN)</b>					
Minimum switching frequency	$R_{RT} = 240\text{ k}\Omega$ (1%)	160	200	240	kHz
Switching frequency	$R_{RT} = 100\text{ k}\Omega$ (1%)	400	480	560	kHz
Maximum switching frequency	$R_{RT} = 29\text{ k}\Omega$ (1%)	1440	1600	1760	kHz
Minimum pulse width			20		ns
RT/CLK high threshold				2	V
RT/CLK low threshold		0.8			V
RT/CLK falling edge to PH rising edge delay	Measure at 500 kHz with RT resistor in series		66		ns
Switching frequency range (RT mode set point and PLL mode)		200		1600	kHz
<b>PH (PH PIN)</b>					
Minimum on-time	Measured at 90% to 90% of $V_{IN}$ , $25^{\circ}\text{C}$ , $I_{PH} = 2\text{ A}$		94	145	ns
Minimum off-time	$BOOT-PH \geq 3\text{ V}$		0		ns
<b>BOOT (BOOT PIN)</b>					
BOOT-PH UVLO			2.1	3	V
<b>SLOW START AND TRACKING (SS/TR PIN)</b>					
SS charge current			2.3		$\mu\text{A}$
SS/TR to VSENSE matching	$V_{(SS/TR)} = 0.4\text{ V}$		20	60	mV
<b>POWER GOOD (PWRGD PIN)</b>					
VSENSE threshold	VSENSE falling (Fault)		92%		$V_{ref}$
VSENSE rising (good)			94%		$V_{ref}$
VSENSE rising (Fault)			106%		$V_{ref}$
VSENSE falling (Good)			104%		$V_{ref}$
Output high leakage	$V_{SENSE} = V_{ref}$ , $V_{(PWRGD)} = 5.5\text{ V}$		30	100	nA
Output low	$I_{(PWRGD)} = 2\text{ mA}$			0.3	V
Minimum $V_{IN}$ for valid output	$V_{(PWRGD)} < 0.5\text{ V}$ at $100\text{ }\mu\text{A}$		0.6	1	V
Minimum SS/TR voltage for PWRGD				1.4	V

## 6.6 Typical Characteristics

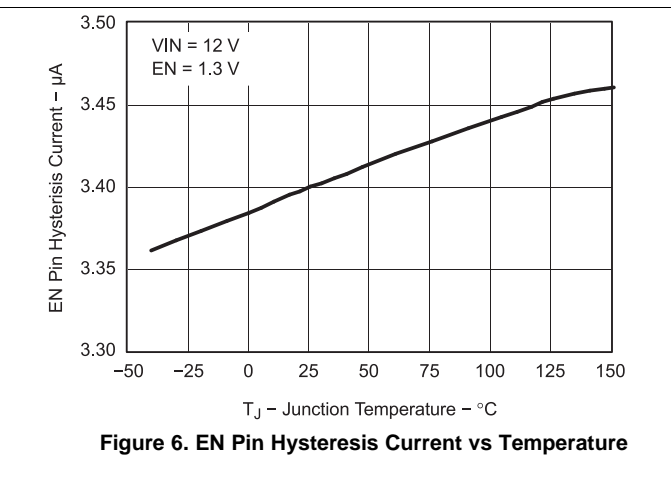
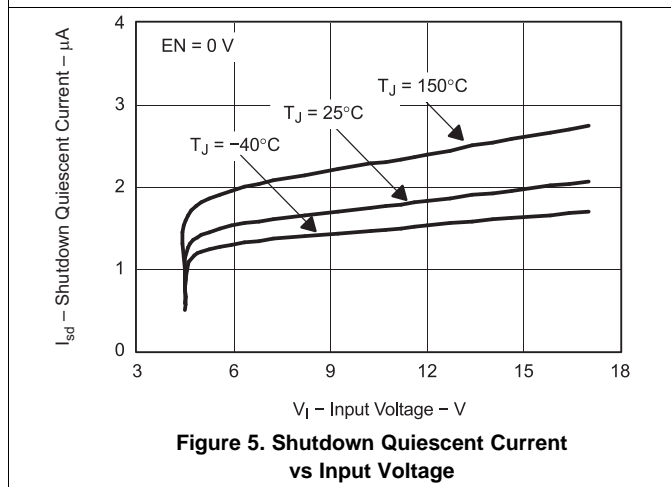
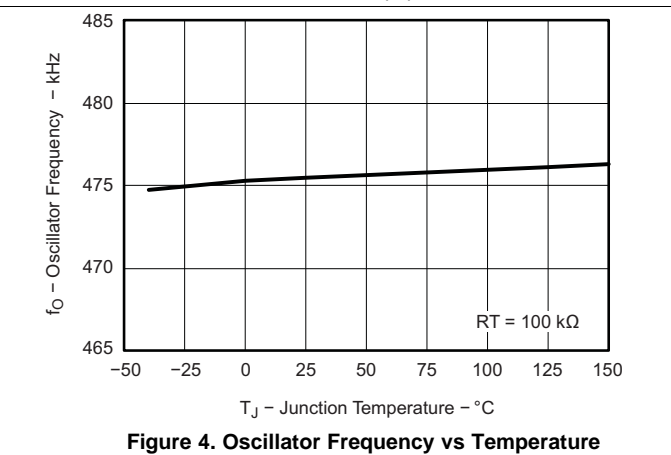
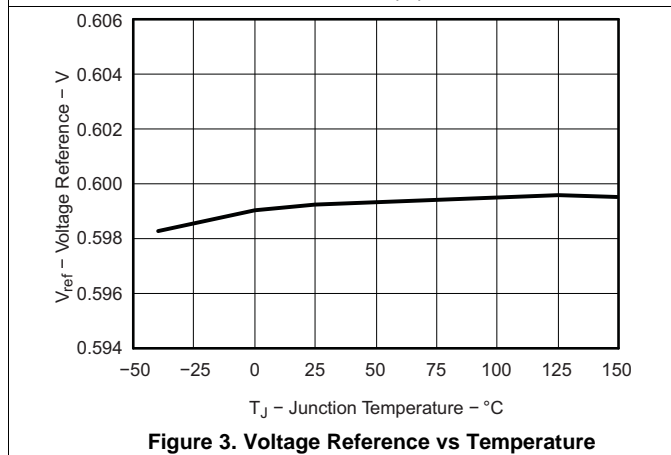
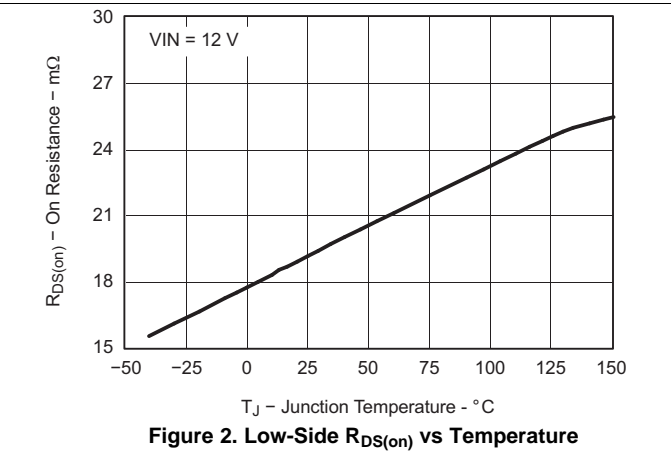
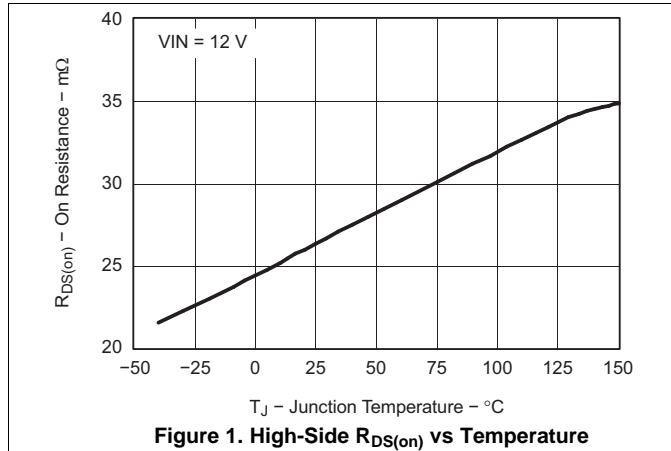

Typical Characteristics (continued)

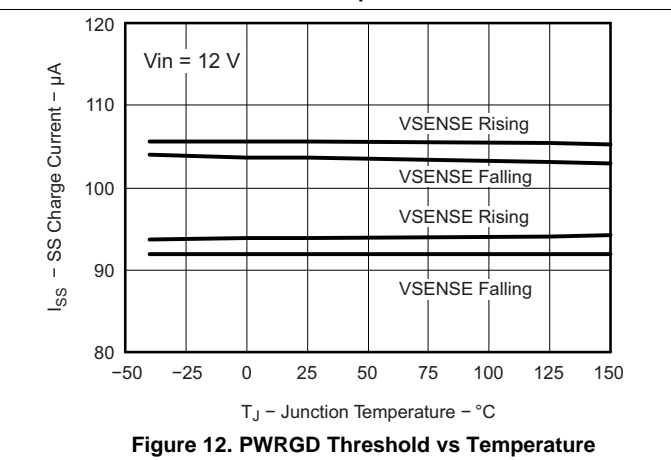
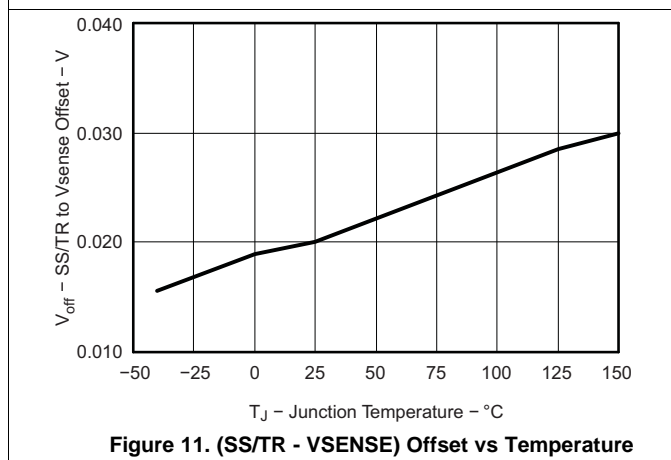
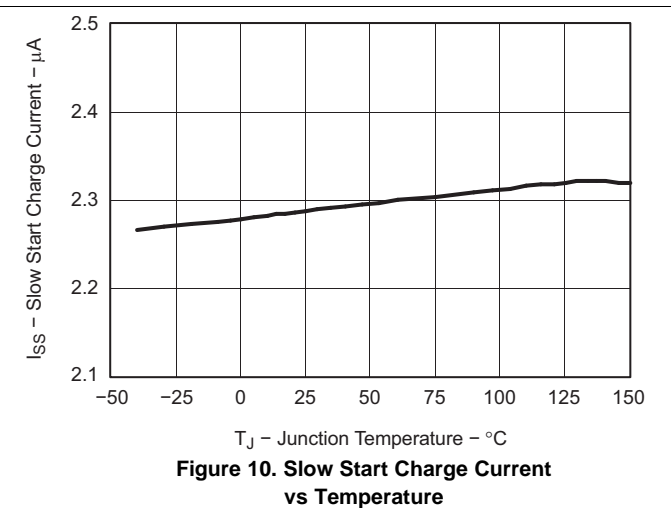
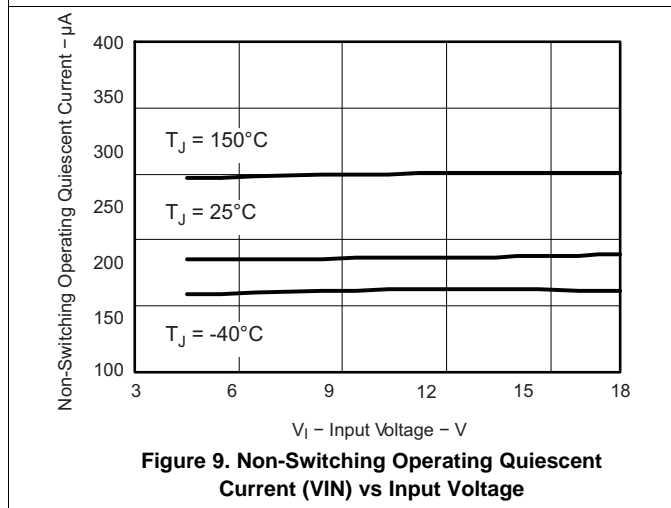
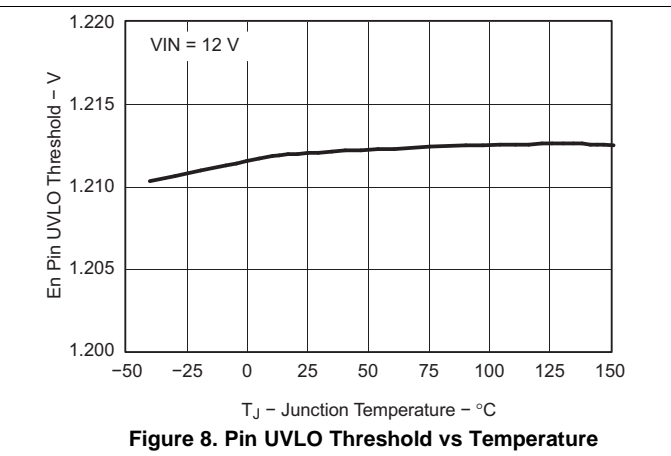
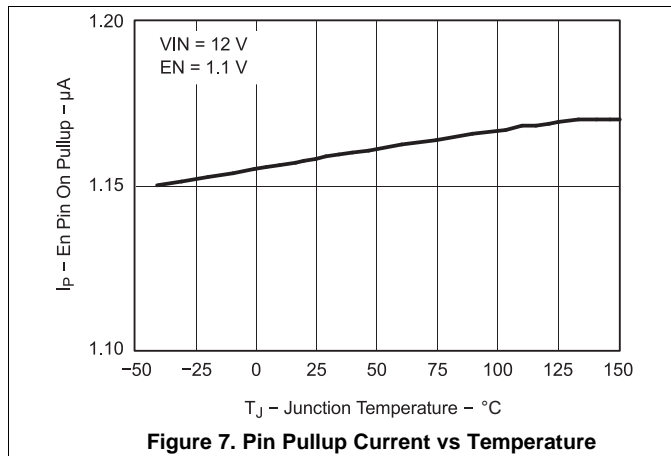



Typical Characteristics (continued)

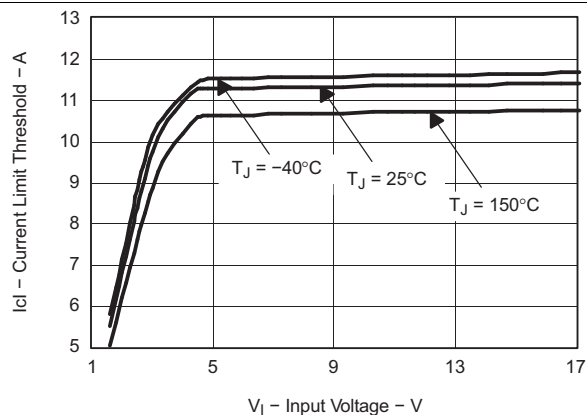

Figure 13. High-Side Current limit Threshold vs Input Voltage

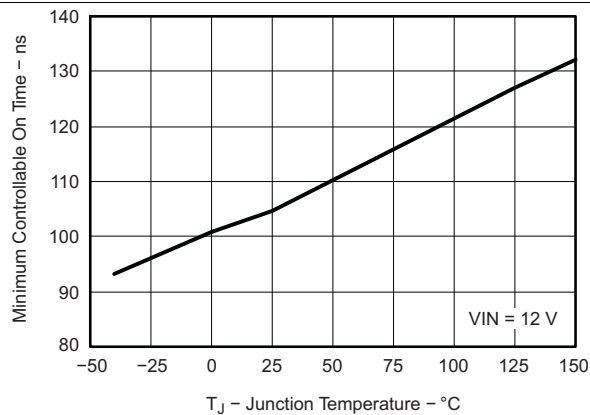

Figure 14. Minimum Controllable On Time vs Temperature

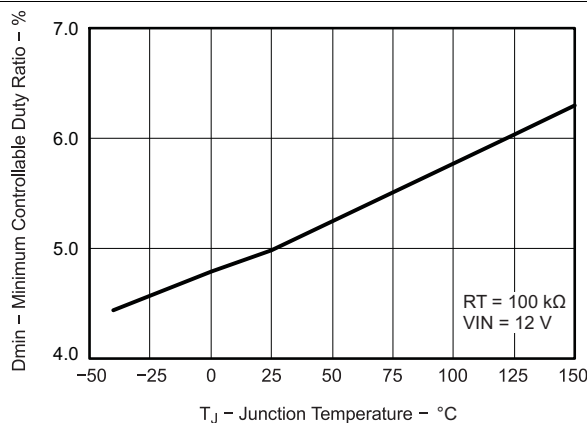

Figure 15. Minimum Controllable Duty Ratio vs Junction Temperature

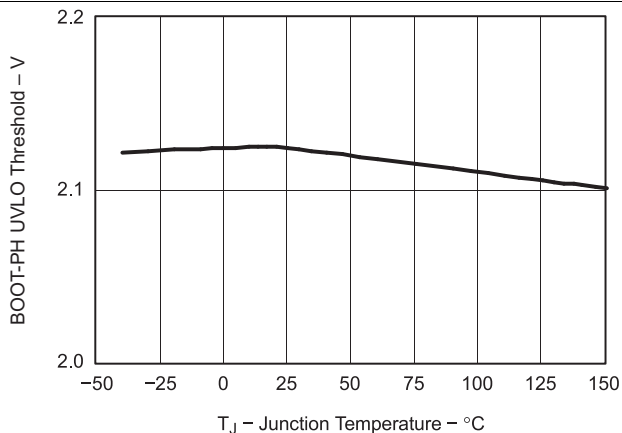

Figure 16. BOOT-PH UVLO Threshold vs Temperature

## 7 Detailed Description

### 7.1 Overview

The device is a 17-V, 6-A, synchronous step-down (buck) converter with two integrated n-channel MOSFETs. To improve performance during line and load transients the device implements a constant frequency, peak current mode control which also simplifies external frequency compensation. The wide switching frequency of 200 kHz to 1600 kHz allows for efficiency and size optimization when selecting the output filter components. The switching frequency is adjusted using a resistor to ground on the RT/CLK pin. The device also has an internal phase lock loop (PLL) controlled by the RT/CLK pin that can be used to synchronize the switching cycle to the falling edge of an external system clock.

The device has been designed for safe monotonic start-up into pre-biased loads. The default start up is when VIN is typically 4 V. The EN pin has an internal pullup current source that can be used to adjust the input voltage under voltage lockout (UVLO) with two external resistors. In addition, the EN pin can be floating for the device to operate with the internal pullup current. The total operating current for the device is approximately 600  $\mu$ A when not switching and under no load. When the device is disabled, the supply current is typically less than 2  $\mu$ A.

The integrated MOSFETs allow for high efficiency power supply designs with continuous output currents up to 6 A. The MOSFETs have been sized to optimize efficiency for lower duty cycle applications.

The device reduces the external component count by integrating the boot recharge circuit. The bias voltage for the integrated high-side MOSFET is supplied by a capacitor between the BOOT and PH pins. The boot capacitor voltage is monitored by a BOOT to PH UVLO (BOOT-PH UVLO) circuit allowing PH pin to be pulled low to recharge the boot capacitor. The device can operate at 100% duty cycle as long as the boot capacitor voltage is higher than the preset BOOT-PH UVLO threshold which is typically 2.1 V. The output voltage can be stepped down to as low as the 0.6 V voltage reference (Vref).

The device has a power good comparator (PWRGD) with hysteresis which monitors the output voltage through the VSENSE pin. The PWRGD pin is an open drain MOSFET which is pulled low when the VSENSE pin voltage is less than 92% or greater than 106% of the reference voltage Vref and asserts high when the VSENSE pin voltage is 94% to 104% of the Vref.

The SS/TR (slow start/tracking) pin is used to minimize inrush currents or provide power supply sequencing during power up. A small value capacitor or resistor divider should be coupled to the pin for slow start or critical power supply sequencing requirements.

The device is protected from output overvoltage, overload and thermal fault conditions. The device minimizes excessive output overvoltage transients by taking advantage of the overvoltage circuit power good comparator. When the overvoltage comparator is activated, the high-side MOSFET is turned off and prevented from turning on until the VSENSE pin voltage is lower than 104% of the Vref. The device implements both high-side MOSFET overload protection and bidirectional low-side MOSFET overload protections which help control the inductor current and avoid current runaway. The device also shuts down if the junction temperature is higher than thermal shutdown trip point. The device is restarted under control of the slow start circuit automatically after the built-in thermal shutdown hiccup time.

The TPS54623 monitors the peak switch current of the high-side MOSFET. Once the peak switch current is lower than typically 1 A, the device stops switching to boost the efficiency until the peak switch current is higher than typically 1 A again.

## 7.2 Functional Block Diagram

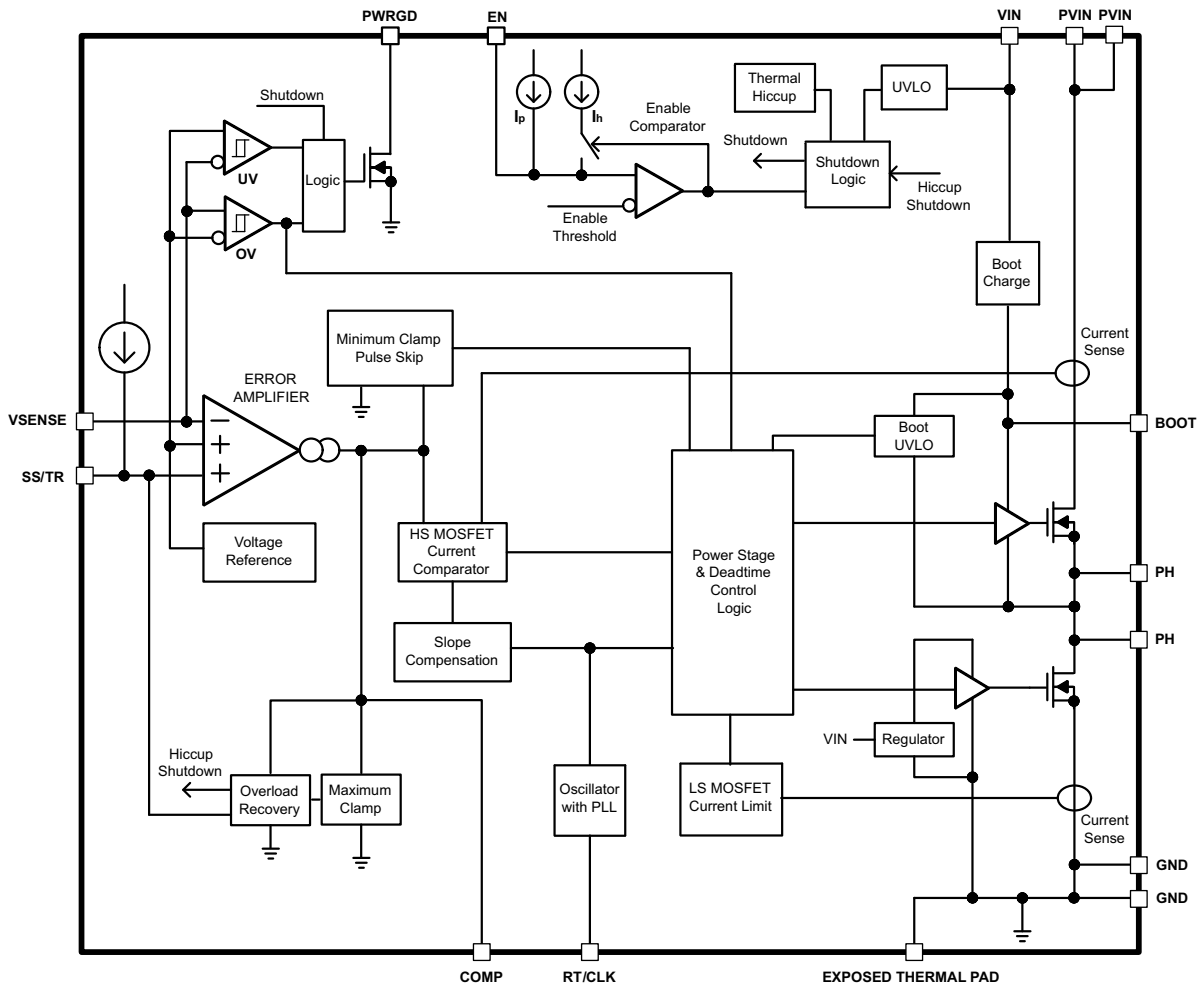

Copyright © 2016, Texas Instruments Incorporated

## 7.3 Feature Description

### 7.3.1 VIN and Power VIN Pins (VIN and PVIN)

The device allows for a variety of applications by using the VIN and PVIN pins together or separately. The VIN pin voltage supplies the internal control circuits of the device. The PVIN pin voltage provides the input voltage to the power converter system.

If tied together, the input voltage for VIN and PVIN can range from 4.5 V to 17 V. If using the VIN separately from PVIN, the VIN pin must be between 4.5 V and 17 V, and the PVIN pin can range from as low as 1.6 V to 17 V. A voltage divider connected to the EN pin can adjust the either input voltage UVLO appropriately. Adjusting the input voltage UVLO on the PVIN pin helps to provide consistent power up behavior.

### 7.3.2 Voltage Reference

The voltage reference system produces a precise  $\pm 1\%$  voltage reference over temperature by scaling the output of a temperature stable bandgap circuit.

## Feature Description (continued)

### 7.3.3 Adjusting the Output Voltage

The output voltage is set with a resistor divider from the output (VOUT) to the VSENSE pin. It is recommended to use 1% tolerance or better divider resistors. Referring to the application schematic of [Figure 31](#), start with a 10 kΩ for R6 and use [Equation 1](#) to calculate R5. To improve efficiency at light loads consider using larger value resistors. If the values are too high the regulator is more susceptible to noise and voltage errors from the VSENSE input current are noticeable.

$$R5 = \frac{V_o - V_{ref}}{V_{ref}} R6$$

where

- $V_{ref} = 0.6 \text{ V}$  (1)

The minimum output voltage and maximum output voltage can be limited by the minimum on time of the high-side MOSFET and bootstrap voltage (BOOT-PH voltage) respectively. More discussions are located in [Minimum Output Voltage](#) and [Bootstrap Voltage \(BOOT\) and Low Dropout Operation](#).

### 7.3.4 Safe Start-up into Pre-Biased Outputs

The device has been designed to prevent the low-side MOSFET from discharging a pre-biased output. During monotonic pre-biased startup, the low-side MOSFET is not allowed to sink current until the SS/TR pin voltage is higher than 1.4 V.

### 7.3.5 Error Amplifier

The device uses a transconductance error amplifier. The error amplifier compares the VSENSE pin voltage to the lower of the SS/TR pin voltage or the internal 0.6 V voltage reference. The transconductance of the error amplifier is 1300 μA/V during normal operation. The frequency compensation network is connected between the COMP pin and ground.

### 7.3.6 Slope Compensation

The device adds a compensating ramp to the switch current signal. This slope compensation prevents sub-harmonic oscillations. The available peak inductor current remains constant over the full duty cycle range.

### 7.3.7 Enable and Adjusting Undervoltage Lockout

The EN pin provides electrical on/off control of the device. Once the EN pin voltage exceeds the threshold voltage, the device starts operation. If the EN pin voltage is pulled below the threshold voltage, the regulator stops switching and enters low Iq state.

The EN pin has an internal pullup current source, allowing the user to float the EN pin for enabling the device. If an application requires controlling the EN pin, use open drain or open collector output logic to interface with the pin.

The device implements internal UVLO circuitry on the VIN pin. The device is disabled when the VIN pin voltage falls below the internal VIN UVLO threshold. The internal VIN UVLO threshold has a hysteresis of 150 mV.

If an application requires either a higher UVLO threshold on the VIN pin or a secondary UVLO on the PVIN, in split rail applications, then the EN pin can be configured as shown in [Figure 17](#), [Figure 18](#) and [Figure 19](#). When using the external UVLO function it is recommended to set the hysteresis to be greater than 500 mV.

The EN pin has a small pullup current  $I_p$  which sets the default state of the pin to enable when no external components are connected. The pullup current is also used to control the voltage hysteresis for the UVLO function since it increases by  $I_h$  once the EN pin crosses the enable threshold. The UVLO thresholds can be calculated using [Equation 2](#) and [Equation 3](#).

Feature Description (continued)

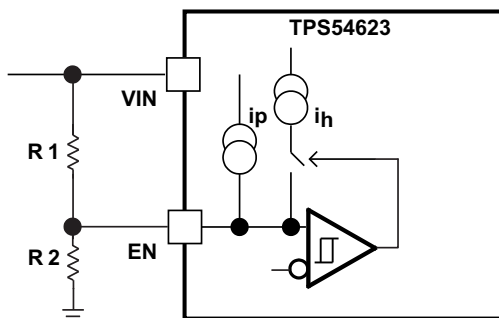

Copyright © 2016, Texas Instruments Incorporated

Figure 17. Adjustable VIN Undervoltage Lockout

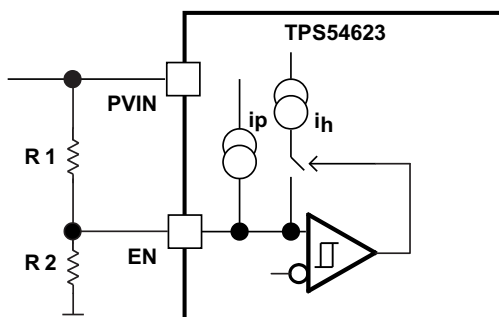

Copyright © 2016, Texas Instruments Incorporated

Figure 18. Adjustable PVIN Undervoltage Lockout, VIN ≥ 4.5 V

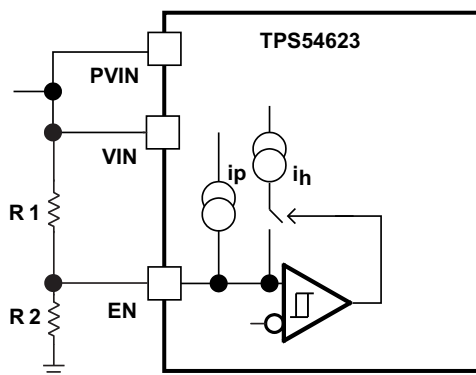

Copyright © 2016, Texas Instruments Incorporated

Figure 19. Adjustable VIN and PVIN Undervoltage Lockout

## Feature Description (continued)

$$R1 = \frac{V_{START} \left( \frac{V_{ENFALLING}}{V_{ENRISING}} \right) - V_{STOP}}{I_p \left( 1 - \frac{V_{ENFALLING}}{V_{ENRISING}} \right) + I_h} \quad (2)$$

$$R2 = \frac{R1 \times V_{ENFALLING}}{V_{STOP} - V_{ENFALLING} + R1(I_p + I_h)}$$

where

- $I_h = 3.4 \mu\text{A}$
  - $I_p = 1.15 \mu\text{A}$
  - $V_{ENRISING} = 1.21 \text{ V}$
  - $V_{ENFALLING} = 1.17 \text{ V}$
- (3)

### 7.3.8 Slow Start (SS/TR)

The device uses the lower voltage of the internal voltage reference or the SS/TR pin voltage as the reference voltage and regulates the output accordingly. A capacitor on the SS/TR pin to ground implements a slow start time. The device has an internal pullup current source of 2.3  $\mu\text{A}$  that charges the external slow start capacitor. The calculations for the slow start time ( $t_{SS}$ , 10% to 90%) and slow start capacitor ( $C_{SS}$ ) are shown in [Equation 4](#). The voltage reference ( $V_{ref}$ ) is 0.6 V and the slow start charge current ( $I_{SS}$ ) is 2.3  $\mu\text{A}$ .

$$t_{SS} \text{ (ms)} = \frac{C_{SS} \text{ (nF)} \times V_{ref} \text{ (V)}}{I_{SS} \text{ (\mu A)}} \quad (4)$$

When the input UVLO is triggered, the EN pin is pulled below 1.21 V, or a thermal shutdown event occurs the device stops switching and enters low current operation. At the subsequent power up, when the shutdown condition is removed, the device does not start switching until it has discharged its SS/TR pin to ground ensuring proper soft start behavior.

### 7.3.9 Power Good (PWRGD)

The PWRGD pin is an open drain output. Once the VSENSE pin is between 94% and 104% of the internal voltage reference the PWRGD pin pull-down is de-asserted and the pin floats. It is recommended to use a pullup resistor between the values of 10 k $\Omega$  and 100 k $\Omega$  to a voltage source that is 5.5 V or less. The PWRGD is in a defined state once the VIN input voltage is greater than 1 V but with reduced current sinking capability. The PWRGD achieves full current sinking capability once the VIN input voltage is above 4.5 V.

The PWRGD pin is pulled low when VSENSE is lower than 92% or greater than 106% of the nominal internal reference voltage. Also, the PWRGD is pulled low, if the input UVLO or thermal shutdown are asserted, the EN pin is pulled low or the SS/TR pin is below 1.4 V.

### 7.3.10 Bootstrap Voltage (BOOT) and Low Dropout Operation

The device has an integrated boot regulator, and requires a small ceramic capacitor between the BOOT and PH pins to provide the gate drive voltage for the high-side MOSFET. The boot capacitor is charged when the BOOT pin voltage is less than VIN and BOOT-PH voltage is below regulation. The value of this ceramic capacitor should be 0.1  $\mu\text{F}$ . A ceramic capacitor with an X7R or X5R grade dielectric with a voltage rating of 10 V or higher is recommended because of the stable characteristics over temperature and voltage.

To improve drop out, the device is designed to operate at 100% duty cycle as long as the BOOT to PH pin voltage is greater than the BOOT-PH UVLO threshold which is typically 2.1 V. When the voltage between BOOT and PH drops below the BOOT-PH UVLO threshold the high-side MOSFET is turned off and the low-side MOSFET is turned on allowing the boot capacitor to be recharged. In applications with split input voltage rails 100% duty cycle operation can be achieved as long as  $(V_{IN} - P_{VIN}) > 4 \text{ V}$ .

## Feature Description (continued)

### 7.3.11 Sequencing (SS/TR)

Many of the common power supply sequencing methods can be implemented using the SS/TR, EN and PWRGD pins.

The sequential method is illustrated in [Figure 20](#) using two TPS54623 devices. The power good of the first device is coupled to the EN pin of the second device, which enables the second power supply once the primary supply reaches regulation.

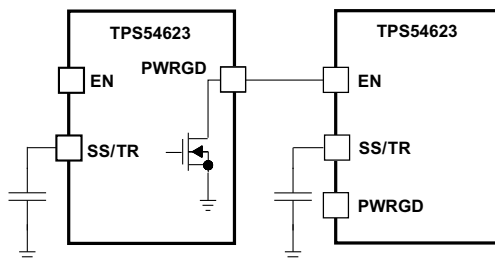

Copyright © 2016, Texas Instruments Incorporated

**Figure 20. Sequential Start-Up Sequence**

[Figure 21](#) shows the method implementing ratio-metric sequencing by connecting the SS/TR pins of two devices together. The regulator outputs ramp up and reach regulation at the same time. When calculating the slow start time the pullup current source must be doubled in [Equation 4](#).

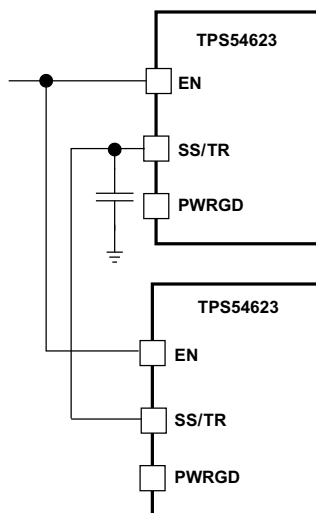

Copyright © 2016, Texas Instruments Incorporated

**Figure 21. Ratiometric Start-Up Sequence**

Ratio-metric and simultaneous power supply sequencing can be implemented by connecting the resistor network of R1 and R2 shown in [Figure 22](#) to the output of the power supply that needs to be tracked or another voltage reference source. Using [Equation 5](#) and [Equation 6](#), the tracking resistors can be calculated to initiate the Vout2 slightly before, after or at the same time as Vout1. [Equation 7](#) is the voltage difference between Vout1 and Vout2.

To design a ratio-metric start up in which the Vout2 voltage is slightly greater than the Vout1 voltage when Vout2 reaches regulation, use a negative number in [Equation 5](#) and [Equation 6](#) for deltaV. [Equation 7](#) results in a positive number for applications where the Vout2 is slightly lower than Vout1 when Vout2 regulation is achieved. .

## Feature Description (continued)

The  $\Delta V$  variable is zero volt for simultaneous sequencing. To minimize the effect of the inherent SS/TR to VSENSE offset ( $V_{ssoffset}$ , 29 mV) in the slow start circuit and the offset created by the pullup current source ( $I_{ss}$ , 2.3  $\mu$ A) and tracking resistors, the  $V_{ssoffset}$  and  $I_{ss}$  are included as variables in the equations.

To ensure proper operation of the device, the calculated R1 value from Equation 5 must be greater than the value calculated in Equation 8.

$$R1 = \frac{V_{out2} + \Delta V}{V_{ref}} \times \frac{V_{ssoffset}}{I_{ss}} \quad (5)$$

$$R2 = \frac{V_{ref} \times R1}{V_{out2} + \Delta V - V_{ref}} \quad (6)$$

$$\Delta V = V_{out1} - V_{out2} \quad (7)$$

$$R1 > 2800 \times V_{out1} - 180 \times \Delta V \quad (8)$$

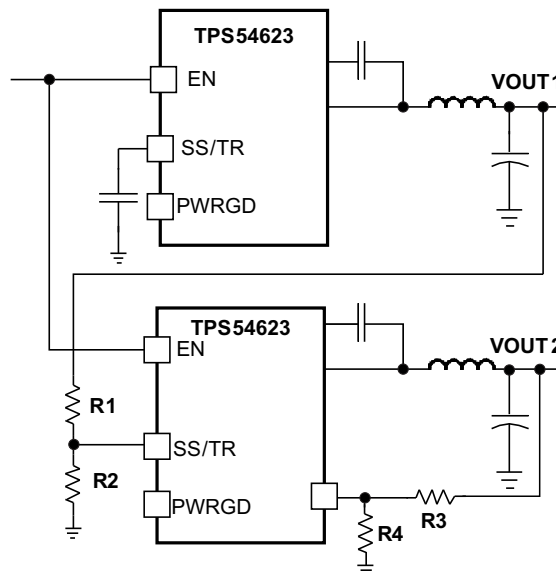

Copyright © 2016, Texas Instruments Incorporated

**Figure 22. Ratiometric and Simultaneous Start-up Sequence**

There are two final considerations when using a resistor divider to the SS/TR pin for simultaneous start-up. First, as described in *Power Good (PWRGD)*, for the PWRGD output to be active the SS/TR voltage must be above 1.4 V. The external divider may prevent the SS/TR voltage from charging above the threshold. For the SS/TR pin to charge above the threshold, an external MOSFET may be needed to disconnect the resistor divider or modify the resistor divider ratio after start-up is complete. The PWRGD pin of the  $V_{OUT(1)}$  converter could be used to turn on or turn off the external MOSFET. Second, a pre-bias on  $V_{OUT(1)}$  may prevent  $V_{OUT(2)}$  from turning on. When the TPS54623 is enabled, an internal 700- $\Omega$  MOSFET at the SS/TR pin turns on to discharge the SS/TR voltage as described in *Slow Start (SS/TR)*. The SS/TR pin voltage must discharge below 20 mV before the TPS54623 starts up. If the upper resistor at the SS/TR pin is too small, the SS/TR pin does not discharge below the threshold, and  $V_{OUT(2)}$  does not ramp up. The upper resistor in the SS/TR divider may need to be increased to allow the SS/TR pin to discharge below the threshold.



## Feature Description (continued)

### 7.3.12 Output Overvoltage Protection (OVP)

The device incorporates an output overvoltage protection (OVP) circuit to minimize output voltage overshoot. For example, when the power supply output is overloaded the error amplifier compares the actual output voltage to the internal reference voltage. If the VSENSE pin voltage is lower than the internal reference voltage for a considerable time, the output of the error amplifier demands maximum output current. Once the condition is removed, the regulator output rises and the error amplifier output transitions to the steady state voltage. In some applications with small output capacitance, the power supply output voltage can respond faster than the error amplifier. This leads to the possibility of an output overshoot. The OVP feature minimizes the overshoot by comparing the VSENSE pin voltage to the OVP threshold. If the VSENSE pin voltage is greater than the OVP threshold the high-side MOSFET is turned off preventing current from flowing to the output and minimizing output overshoot. When the VSENSE voltage drops lower than the OVP threshold, the high-side MOSFET is allowed to turn on at the next clock cycle.

### 7.3.13 Overcurrent Protection

The device is protected from overcurrent conditions by cycle-by-cycle current limiting on both the high-side MOSFET and the low-side MOSFET.

#### 7.3.13.1 High-side MOSFET Overcurrent Protection

The device implements current mode control which uses the COMP pin voltage to control the turnoff of the high-side MOSFET and the turnon of the low-side MOSFET on a cycle by cycle basis. Each cycle the switch current and the current reference generated by the COMP pin voltage are compared, when the peak switch current intersects the current reference the high-side switch is turned off.

#### 7.3.13.2 Low-side MOSFET Overcurrent Protection

While the low-side MOSFET is turned on its conduction current is monitored by the internal circuitry. During normal operation the low-side MOSFET sources current to the load. At the end of every clock cycle, the low-side MOSFET sourcing current is compared to the internally set low-side sourcing current limit. If the low-side sourcing current is exceeded the high-side MOSFET is not turned on and the low-side MOSFET stays on for the next cycle. The high-side MOSFET is turned on again when the low-side current is below the low-side sourcing current limit at the start of a cycle.

The low-side MOSFET may also sink current from the load. If the low-side sinking current limit is exceeded the low-side MOSFET is turned off immediately for the rest of that clock cycle. In this scenario both MOSFETs are off until the start of the next cycle.

Furthermore, if an output overload condition (as measured by the COMP pin voltage) has lasted for more than the hiccup wait time which is programmed for 512 switching cycles, the device shuts down itself and restart after the hiccup time of 16384 cycles. The hiccup mode helps to reduce the device power dissipation under severe overcurrent conditions.

### 7.3.14 Thermal Shutdown

The internal thermal shutdown circuitry forces the device to stop switching if the junction temperature exceeds 175°C typically. Once the junction temperature drops below 165°C typically, the internal thermal hiccup timer will start to count. The device reinitiates the power up sequence after the built-in thermal shutdown hiccup time (16384 cycles) is over.

### 7.3.15 Small Signal Model for Loop Response

**Figure 23** shows an equivalent model for the device control loop which can be modeled in a circuit simulation program to check frequency response and transient responses. The error amplifier is a transconductance amplifier with a gm of 1300 $\mu$ A/V. The error amplifier can be modeled using an ideal voltage controlled current source. The resistor R<sub>oea</sub> (2.38 M $\Omega$ ) and capacitor C<sub>oea</sub> (20.7 pF) model the open loop gain and frequency response of the error amplifier. The 1-mV ac voltage source between the nodes a and b effectively breaks the control loop for the frequency response measurements. Plotting a/c and c/b show the small signal responses of the power stage and frequency compensation respectively. Plotting a/b shows the small signal response of the overall loop. The dynamic loop response can be checked by replacing the R<sub>L</sub> with a current source with the appropriate load step amplitude and step rate in a time domain analysis.

**Feature Description (continued)**

**Figure 23. Small Signal Model for Loop Response**
**7.3.16 Simple Small Signal Model for Peak Current Mode Control**

Figure 24 is a simple small signal model that can be used to understand how to design the frequency compensation. The device power stage can be approximated to a voltage controlled current source (duty cycle modulator) supplying current to the output capacitor and load resistor. The control to output transfer function is shown in Equation 9 and consists of a dc gain, one dominant pole and one ESR zero. The quotient of the change in switch current and the change in COMP pin voltage (node c in Figure 23) is the power stage transconductance ( $g_{m_{ps}}$ ) which is 16 A/V for the device. The DC gain of the power stage is the product of  $g_{m_{ps}}$  and the load resistance  $R_L$  as shown in Equation 10 with resistive loads. As the load current increases, the DC gain decreases. This variation with load may seem problematic at first glance, but fortunately the dominant pole moves with load current (see Equation 11). The combined effect is highlighted by the dashed line in Figure 25. As the load current decreases, the gain increases and the pole frequency lowers, keeping the 0-dB crossover frequency the same for the varying load conditions which makes it easier to design the frequency compensation.

**Figure 24. Simplified Small Signal Model for Peak Current Mode Control**

Feature Description (continued)

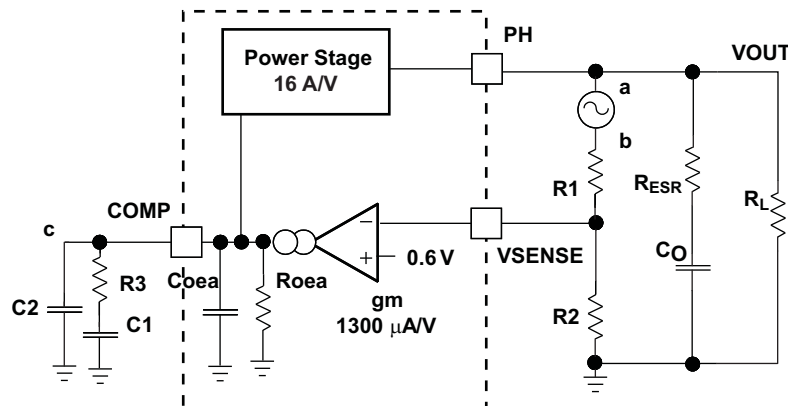
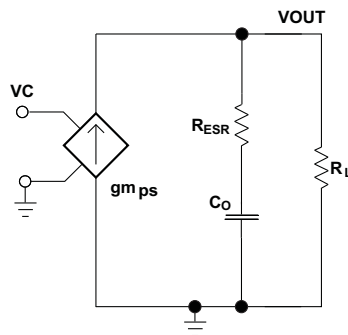
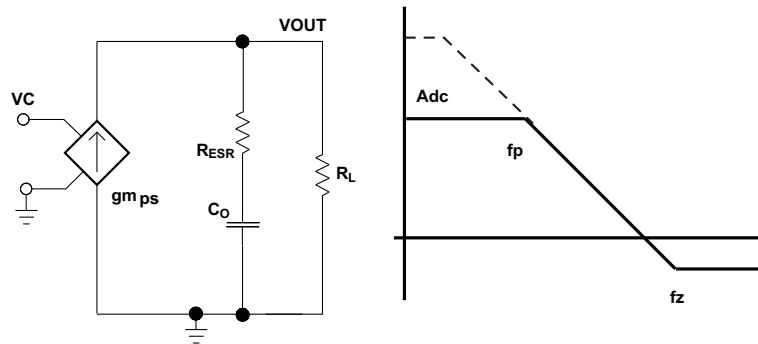

Figure 25. Simplified Frequency Response for Peak Current Mode Control

$$\frac{V_{OUT}}{V_C} = A_{dc} \times \frac{\left(1 + \frac{s}{2\pi \times f_z}\right)}{\left(1 + \frac{s}{2\pi \times f_p}\right)} \tag{9}$$

$$A_{dc} = g_{m_{ps}} \times R_L \tag{10}$$

$$f_p = \frac{1}{C_O \times R_L \times 2\pi} \tag{11}$$

$$f_z = \frac{1}{C_O \times R_{ESR} \times 2\pi}$$

where

- $g_{m_{ea}}$  is the GM amplifier gain (1300  $\mu A/V$ )
  - $g_{m_{ps}}$  is the power stage gain (16  $A/V$ )
  - $R_L$  is the load resistance
  - $C_O$  is the output capacitance
  - $R_{ESR}$  is the equivalent series resistance of the output capacitor
- (12)

7.3.17 Small Signal Model for Frequency Compensation

The device uses a transconductance amplifier for the error amplifier and readily supports two of the commonly used Type II compensation circuits and a Type III frequency compensation circuit, as shown in Figure 26. In Type 2A, one additional high frequency pole, C6, is added to attenuate high frequency noise. In Type III, one additional capacitor, C11, is added to provide a phase boost at the crossover frequency. See *Designing Type III Compensation for Current Mode Step-Down Converters* for a complete explanation of Type III compensation.

The design guidelines below are provided for advanced users who prefer to compensate using the general method. The below equations only apply to designs whose ESR zero is above the bandwidth of the control loop. This is usually true with ceramic output capacitors. See *Typical Application* for a step-by-step design procedure using higher ESR output capacitors with lower ESR zero frequencies.

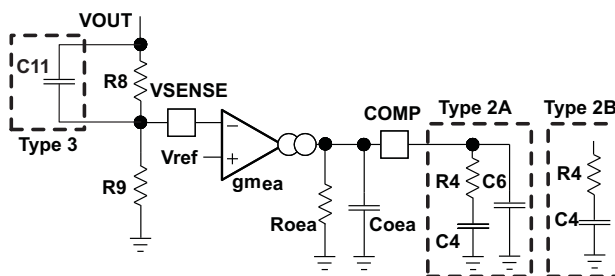
**Feature Description (continued)**

**Figure 26. Types of Frequency Compensation**

The general design guidelines for device loop compensation are as follows:

1. Determine the crossover frequency,  $f_c$ . A good starting point is  $1/10^{\text{th}}$  of the switching frequency,  $f_{sw}$ .
2.  $R_4$  can be determined by [Equation 13](#).

$$R_4 = \frac{2\pi \times f_c \times V_{OUT} \times C_o}{g_{m_{ea}} \times V_{ref} \times g_{m_{ps}}}$$

where

- $g_{m_{ea}}$  is the GM amplifier gain (1300  $\mu\text{A/V}$ )
- $g_{m_{ps}}$  is the power stage gain (16  $\text{A/V}$ )
- $V_{ref}$  is the reference voltage (0.6 V)

(13)

3. Place a compensation zero at the dominant pole:  $\left( f_p = \frac{1}{C_o \times R_L \times 2\pi} \right)$

$C_4$  can be determined by [Equation 14](#).

$$C_4 = \frac{R_L \times C_o}{R_4}$$

(14)

4.  $C_6$  is optional. It can be used to cancel the zero from the equivalent series resistance (ESR) of the output capacitor  $C_o$ .

$$C_6 = \frac{R_{ESR} \times C_o}{R_4}$$

(15)

5. Type III compensation can be implemented with the addition of one capacitor,  $C_{11}$ . This allows for slightly higher loop bandwidths and higher phase margins. If used,  $C_{11}$  is calculated from [Equation 16](#).

$$C_{11} = \frac{1}{(2 \cdot \pi \cdot R_8 \cdot f_c)}$$

(16)

## 7.4 Device Functional Modes

### 7.4.1 Fixed Frequency PWM Control

The device uses a adjustable fixed frequency, peak current mode control. The output voltage is compared through external resistors on the VSENSE pin to an internal voltage reference by an error amplifier which drives the COMP pin. An internal oscillator initiates the turn on of the high-side power switch. The error amplifier output is converted into a current reference which compares to the high-side power switch current. When the power switch current reaches current reference generated by the COMP voltage level the high-side power switch is turned off and the low-side power switch is turned on.

### 7.4.2 Continuous Current Mode Operation (CCM)

As a synchronous buck converter, the device normally works in CCM (Continuous Conduction Mode) under load conditions where the minimum inductor valley current is higher than 0 A.

### 7.4.3 Light Load Efficiency Operation

The TPS54623 operates in pulse skip mode (see [Figure 28](#)) at light load currents to improve efficiency by reducing switching and gate drive losses. The TPS54623 is designed so that if the output voltage is within regulation and the peak switch current at the end of any switching cycle is below the pulse skipping current threshold, the device enters pulse skip mode. This current threshold is the current level corresponding to a nominal COMP voltage of 250 mV.

When in pulse skip mode, the COMP pin voltage is clamped and the high side MOSFET is inhibited. Further decreases in load current or in output voltage can not drive the COMP pin below this clamp voltage level.

Since the device is not switching, the output voltage begins to decay. As the voltage control loop compensates for the falling output voltage, the COMP pin voltage begins to rise. At this time, the high side MOSFET is enabled and a switching pulse initiates on the next switching cycle. The peak current is set by the COMP pin voltage. The output voltage re-charges the regulated value, then the peak switch current starts to decrease, and eventually falls below the pulse skip mode threshold at which time the device again enters pulse skip mode.

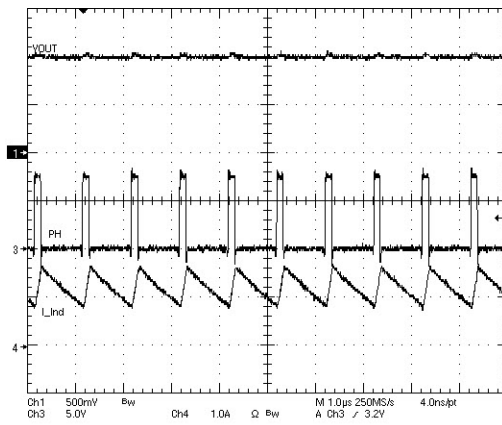

Figure 27. TPS54623 Operation In Current Mode

## Device Functional Modes (continued)

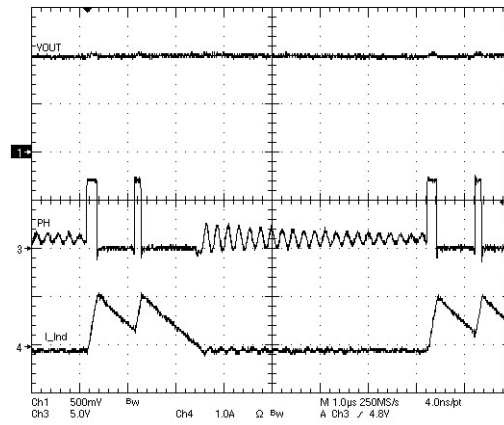

Figure 28. TPS54623 Operation In Pulse Skipping Mode

### 7.4.4 Adjustable Switching Frequency and Synchronization (RT/CLK)

The RT/CLK pin can be used to set the switching frequency of the device in two modes.

In RT mode, a resistor (RT resistor) is connected between the RT/CLK pin and GND. The switching frequency of the device is adjustable from 200 kHz to 1600 kHz by placing a maximum of 240 kΩ and minimum of 29 kΩ respectively. In CLK mode, an external clock is connected directly to the RT/CLK pin. The device is synchronized to the external clock frequency with PLL.

The CLK mode overrides the RT mode. The device is able to detect the proper mode automatically and switch from the RT mode to CLK mode.

#### 7.4.4.1 Adjustable Switching Frequency (RT Mode)

To determine the RT resistance for a given switching frequency, use Equation 17 or the curve in Figure 29. To reduce the solution size one would set the switching frequency as high as possible, but tradeoffs of the supply efficiency and minimum controllable on time should be considered.

$$R_{rt}(k\Omega) = 48000 \cdot F_{sw}(\text{kHz})^{-0.997} - 2 \tag{17}$$

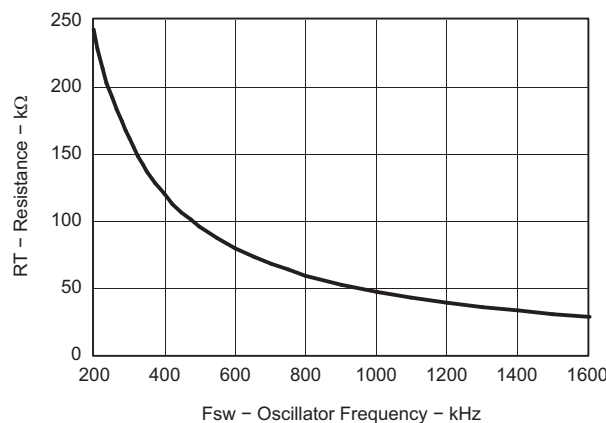

Figure 29. RT Set Resistor vs Switching Frequency

#### 7.4.4.2 Synchronization (CLK mode)

An internal phase locked loop (PLL) has been implemented to allow synchronization between 200 kHz and 1600 kHz, and to easily switch from RT mode to CLK mode.

### Device Functional Modes (continued)

To implement the synchronization feature, connect a square wave clock signal to the RT/CLK pin with a duty cycle between 20% to 80%. The clock signal amplitude must transition lower than 0.8 V and higher than 2 V. The start of the switching cycle is synchronized to the falling edge of RT/CLK pin.

In applications where both RT mode and CLK mode are needed, the device can be configured as shown in Figure 30. Before the external clock is present, the device works in RT mode and the switching frequency is set by RT resistor. When the external clock is present, the CLK mode overrides the RT mode. The first time the SYNC pin is pulled above the RT/CLK high threshold (2 V), the device switches from the RT mode to the CLK mode and the RT/CLK pin becomes high impedance as the PLL starts to lock onto the frequency of the external clock. It is not recommended to switch from the CLK mode back to the RT mode because the internal switching frequency drops to 100 kHz first before returning to the switching frequency set by RT resistor.

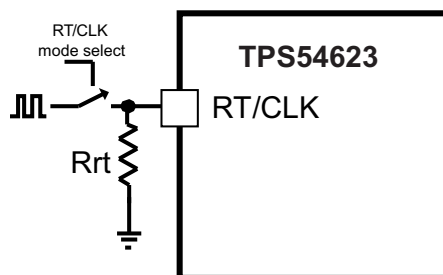

Copyright © 2016, Texas Instruments Incorporated

Figure 30. Works with Both RT Mode and CLK Mode

## 8 Application and Implementation

### NOTE

Information in the following applications sections is not part of the TI component specification, and TI does not warrant its accuracy or completeness. TI's customers are responsible for determining suitability of components for their purposes. Customers should validate and test their design implementation to confirm system functionality.

### 8.1 Application Information

#### 8.1.1 Fast Transient Considerations

In applications where fast transient responses are important, Type III frequency compensation can be used instead of the traditional Type II frequency compensation.

For more information about Type II and Type III frequency compensation circuits, see *Designing Type III Compensation for Current Mode Step-Down Converters* (SLVA352) and Design Calculator (SLVC219).

### 8.2 Typical Application

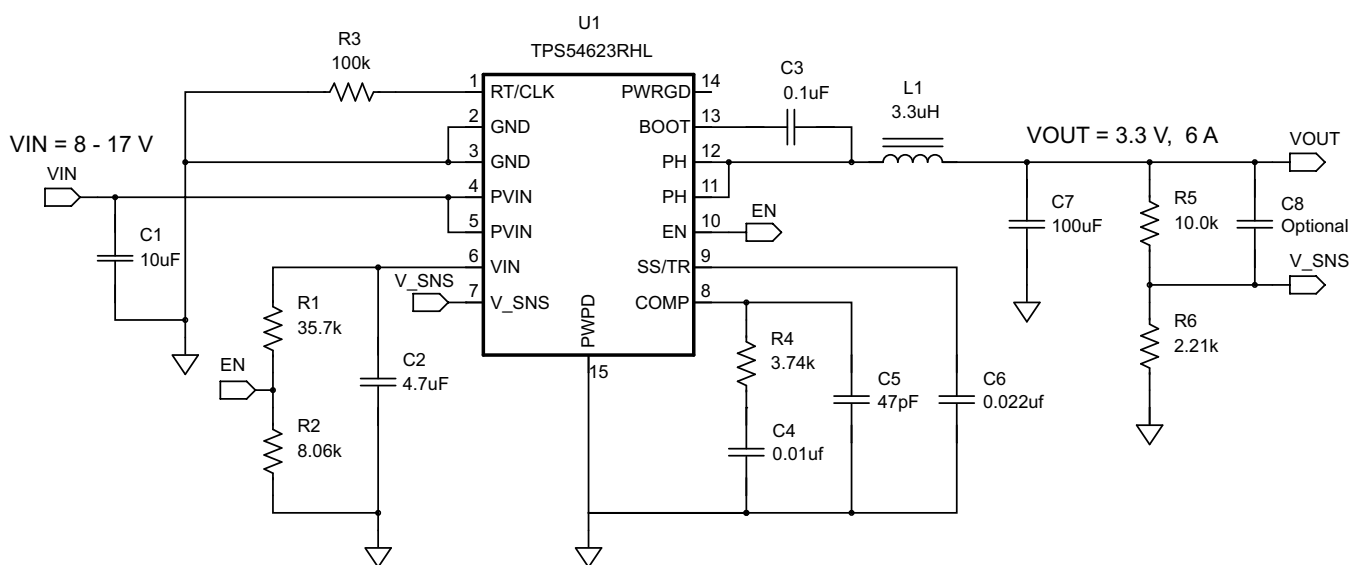

Copyright © 2016, Texas Instruments Incorporated

**Figure 31. Typical Application Circuit**

#### 8.2.1 Design Requirements

This example details the design of a high frequency switching regulator design using ceramic output capacitors. A few parameters must be known in order to start the design process. These parameters are typically determined at the system level. For this example, start with the parameters in [Table 1](#).



## Typical Application (continued)

**Table 1. Design Parameters**

PARAMETER	VALUE
Output voltage	3.3 V
Output current	6 A
Transient response 1-A load step	$\Delta V_{OUT} = 5\%$
Input voltage	12 V nominal, 8 V to 17 V
Output voltage ripple	33 mV p-p
Start input voltage (rising $V_{IN}$ )	6.528 V
Stop input voltage (falling $V_{IN}$ )	6.19 V
Switching frequency	480 kHz

### 8.2.2 Detailed Design Procedure

#### 8.2.2.1 Custom Design With WEBENCH® Tools

[Click here](#) to create a custom design using the TPS54623 device with the WEBENCH® Power Designer.

1. Start by entering the input voltage ( $V_{IN}$ ), output voltage ( $V_{OUT}$ ), and output current ( $I_{OUT}$ ) requirements.
2. Optimize the design for key parameters such as efficiency, footprint, and cost using the optimizer dial.
3. Compare the generated design with other possible solutions from Texas Instruments.

The WEBENCH Power Designer provides a customized schematic along with a list of materials with real-time pricing and component availability.

In most cases, these actions are available:

- Run electrical simulations to see important waveforms and circuit performance
- Run thermal simulations to understand board thermal performance
- Export customized schematic and layout into popular CAD formats
- Print PDF reports for the design, and share the design with colleagues

Get more information about WEBENCH tools at [www.ti.com/WEBENCH](http://www.ti.com/WEBENCH).

#### 8.2.2.2 Operating Frequency

The first step is to decide on a switching frequency for the regulator. There is a trade off between higher and lower switching frequencies. Higher switching frequencies may produce smaller a solution size using lower valued inductors and smaller output capacitors compared to a power supply that switches at a lower frequency. However, the higher switching frequency causes extra switching losses, which hurt the converter's efficiency and thermal performance. In this design, a moderate switching frequency of 480 kHz is selected to achieve both a small solution size and a high efficiency operation.

#### 8.2.2.3 Output Inductor Selection

To calculate the value of the output inductor, use [Equation 18](#).  $KIND$  is a coefficient that represents the amount of inductor ripple current relative to the maximum output current. The inductor ripple current is filtered by the output capacitor. Therefore, choosing high inductor ripple currents impact the selection of the output capacitor since the output capacitor must have a ripple current rating equal to or greater than the inductor ripple current. In general, the inductor ripple value is at the discretion of the designer; however,  $KIND$  is normally from 0.1 to 0.3 for the majority of applications.

$$L1 = \frac{V_{inmax} - V_{out}}{I_o \cdot Kind} \cdot \frac{V_{out}}{V_{inmax} \cdot f_{sw}} \quad (18)$$

For this design example, use  $KIND = 0.3$  and the inductor value is calculated to be 3.08  $\mu\text{H}$ . For this design, a nearest standard value was chosen: 3.3  $\mu\text{H}$ . For the output filter inductor, it is important that the RMS current and saturation current ratings not be exceeded. The RMS and peak inductor current can be found from [Equation 20](#) and [Equation 21](#).

$$I_{\text{ripple}} = \frac{V_{\text{inmax}} - V_{\text{out}}}{L1} \cdot \frac{V_{\text{out}}}{V_{\text{inmax}} \cdot f_{\text{sw}}} \quad (19)$$

$$I_{\text{Lrms}} = \sqrt{I_{\text{o}}^2 + \frac{1}{12} \cdot \left( \frac{V_{\text{o}} \cdot (V_{\text{inmax}} - V_{\text{o}})}{V_{\text{inmax}} \cdot L1 \cdot f_{\text{sw}}} \right)^2} \quad (20)$$

$$I_{\text{Lpeak}} = I_{\text{out}} + \frac{I_{\text{ripple}}}{2} \quad (21)$$

For this design, the RMS inductor current is 6.02 A and the peak inductor current is 6.84 A. The chosen inductor is a Coilcraft MSS1048 series 3.3  $\mu\text{H}$ . It has a saturation current rating of 7.38 A and a RMS current rating of 7.22 A.

The current flowing through the inductor is the inductor ripple current plus the output current. During power up, faults or transient load conditions, the inductor current can increase above the calculated peak inductor current level calculated above. In transient conditions, the inductor current can increase up to the switch current limit of the device. For this reason, the most conservative approach is to specify an inductor with a saturation current rating equal to or greater than the switch current limit rather than the peak inductor current.

### 8.2.2.4 Output Capacitor Selection

There are three primary considerations for selecting the value of the output capacitor. The output capacitor determines the modulator pole, the output voltage ripple, and how the regulator responds to a large change in load current. The output capacitance needs to be selected based on the more stringent of these three criteria.

The desired response to a large change in the load current is the first criteria. The output capacitor needs to supply the load with current when the regulator can not. This situation would occur if there are desired hold-up times for the regulator where the output capacitor must hold the output voltage above a certain level for a specified amount of time after the input power is removed. The regulator is also temporarily not able to supply sufficient output current if there is a large, fast increase in the current needs of the load such as a transition from no load to full load. The regulator usually needs two or more clock cycles for the control loop to see the change in load current and output voltage and adjust the duty cycle to react to the change. The output capacitor must be sized to supply the extra current to the load until the control loop responds to the load change. The output capacitance must be large enough to supply the difference in current for 2 clock cycles while only allowing a tolerable amount of droop in the output voltage. Equation 22 shows the minimum output capacitance necessary to accomplish this.

$$C_{\text{o}} > \frac{2 \cdot \Delta I_{\text{out}}}{f_{\text{sw}} \cdot \Delta V_{\text{out}}} \quad (22)$$

Where  $\Delta I_{\text{out}}$  is the change in output current,  $f_{\text{sw}}$  is the regulators switching frequency and  $\Delta V_{\text{out}}$  is the allowable change in the output voltage. For this example, the transient load response is specified as a 5% change in  $V_{\text{out}}$  for a load step of 1 A. For this example,  $\Delta I_{\text{out}} = 3.0$  A and  $\Delta V_{\text{out}} = 0.05 \times 3.3 = 0.165$  V. Using these numbers gives a minimum capacitance of 75.8  $\mu\text{F}$ . This value does not take the ESR of the output capacitor into account in the output voltage change. For ceramic capacitors, the ESR is usually small enough to ignore in this calculation.

Equation 23 calculates the minimum output capacitance needed to meet the output voltage ripple specification. Where  $f_{\text{sw}}$  is the switching frequency,  $V_{\text{ripple}}$  is the maximum allowable output voltage ripple, and  $I_{\text{ripple}}$  is the inductor ripple current. In this case, the maximum output voltage ripple is 33 mV. Under this requirement, Equation 23 yields 13.2  $\mu\text{F}$ .

$$C_{\text{o}} > \frac{1}{8 \cdot f_{\text{sw}}} \cdot \frac{1}{\frac{V_{\text{ripple}}}{I_{\text{ripple}}}} \quad (23)$$

Equation 24 calculates the maximum ESR an output capacitor can have to meet the output voltage ripple specification. Equation 24 indicates the ESR should be less than 19.7 m $\Omega$ . In this case, the ceramic caps' ESR is much smaller than 19.7 m $\Omega$ .

$$\text{Resr} < \frac{V_{\text{ripple}}}{I_{\text{ripple}}} \quad (24)$$

Additional capacitance de-ratings for aging, temperature and DC bias should be factored in which increases this minimum value. For this example, a 100- $\mu\text{F}$  6.3-V X5R ceramic capacitor with 3  $\text{m}\Omega$  of ESR is used. Capacitors generally have limits to the amount of ripple current they can handle without failing or producing excess heat. An output capacitor that can support the inductor ripple current must be specified. Some capacitor data sheets specify the root mean square (RMS) value of the maximum ripple current. Equation 25 can be used to calculate the RMS ripple current the output capacitor needs to support. For this application, Equation 25 yields 485 mA.

$$I_{\text{corms}} = \frac{V_{\text{out}} \cdot (V_{\text{inmax}} - V_{\text{out}})}{\sqrt{12} \cdot V_{\text{inmax}} \cdot L_1 \cdot f_{\text{sw}}} \quad (25)$$

### 8.2.2.5 Input Capacitor Selection

The TPS54623 requires a high quality ceramic, type X5R or X7R, input decoupling capacitor of at least 4.7  $\mu\text{F}$  of effective capacitance on the PVIN input voltage pins and 4.7  $\mu\text{F}$  on the Vin input voltage pin. In some applications additional bulk capacitance may also be required for the PVIN input. The effective capacitance includes any DC bias effects. The voltage rating of the input capacitor must be greater than the maximum input voltage. The capacitor must also have a ripple current rating greater than the maximum input current ripple of the TPS54623. The input ripple current can be calculated using Equation 26.

$$I_{\text{cirms}} = I_{\text{out}} \cdot \sqrt{\frac{V_{\text{out}}}{V_{\text{inmin}}} \cdot \frac{(V_{\text{inmin}} - V_{\text{out}})}{V_{\text{inmin}}}} \quad (26)$$

The value of a ceramic capacitor varies significantly over temperature and the amount of DC bias applied to the capacitor. The capacitance variations due to temperature can be minimized by selecting a dielectric material that is stable over temperature. X5R and X7R ceramic dielectrics are usually selected for power regulator capacitors because they have a high capacitance to volume ratio and are fairly stable over temperature. The output capacitor must also be selected with the DC bias taken into account. The capacitance value of a capacitor decreases as the DC bias across a capacitor increases. For this example design, a ceramic capacitor with at least a 25 V voltage rating is required to support the maximum input voltage. For this example, one 10  $\mu\text{F}$  and one 4.7  $\mu\text{F}$  25 V capacitors in parallel have been selected as the VIN and PVIN inputs are tied together so the TPS54623 may operate from a single supply. The input capacitance value determines the input ripple voltage of the regulator. The input voltage ripple can be calculated using Equation 27. Using the design example values,  $I_{\text{outmax}} = 6 \text{ A}$ ,  $C_{\text{in}} = 14.7 \mu\text{F}$ ,  $f_{\text{sw}} = 480 \text{ kHz}$ , yields an input voltage ripple of 213 mV and a RMS input ripple current of 2.95 A.

$$\Delta V_{\text{in}} = \frac{I_{\text{outmax}} \cdot 0.25}{C_{\text{in}} \cdot f_{\text{sw}}} \quad (27)$$

### 8.2.2.6 Slow Start Capacitor Selection

The slow start capacitor determines the minimum amount of time it takes for the output voltage to reach its nominal programmed value during power up. This is useful if a load requires a controlled voltage slew rate. This is also used if the output capacitance is very large and would require large amounts of current to quickly charge the capacitor to the output voltage level. The large currents necessary to charge the capacitor may make the TPS54623 reach the current limit or excessive current draw from the input power supply may cause the input voltage rail to sag. Limiting the output voltage slew rate solves both of these problems. The soft start capacitor value can be calculated using Equation 28. For the example circuit, the soft start time is not too critical since the output capacitor value is 100  $\mu\text{F}$  which does not require much current to charge to 3.3 V. The example circuit has the soft start time set to an arbitrary value of 6 ms which requires a 22 nF capacitor. In TPS54623,  $I_{\text{ss}}$  is 2.3  $\mu\text{A}$  and  $V_{\text{ref}}$  is 0.6 V.

$$C_6(\text{nF}) = \frac{T_{\text{ss}}(\text{ms}) \cdot I_{\text{ss}}(\mu\text{A})}{V_{\text{ref}}(\text{V})} \quad (28)$$

### 8.2.2.7 Bootstrap Capacitor Selection

A 0.1- $\mu\text{F}$  ceramic capacitor must be connected between the BOOT to PH pin for proper operation. It is recommended to use a ceramic capacitor with X5R or better grade dielectric. The capacitor should have 10 V or higher voltage rating.

### 8.2.2.8 Under Voltage Lockout Set Point

The Undervoltage Lockout (UVLO) can be adjusted using the external voltage divider network of R3 and R4. R3 is connected between VIN and the EN pin of the TPS54623 and R4 is connected between EN and GND. The UVLO has two thresholds, one for power up when the input voltage is rising and one for power down or brown outs when the input voltage is falling. For the example design, the supply should turn on and start switching once the input voltage increases above 6.528 V (UVLO start or enable). After the regulator starts switching, it should continue to do so until the input voltage falls below 6.190 V (UVLO stop or disable). Equation 2 and Equation 3 can be used to calculate the values for the upper and lower resistor values. For the stop voltages specified the nearest standard resistor value for R3 is 35.7 kΩ and for R4 is 8.06 kΩ.

### 8.2.2.9 Output Voltage Feedback Resistor Selection

The resistor divider network R5 and R6 is used to set the output voltage. For the example design, 10 kΩ was selected for R5. Using Equation 29, R6 is calculated as 2.22 kΩ. The nearest standard 1% resistor is 2.21 kΩ.

$$R6 = \frac{R5 \cdot V_{ref}}{V_o - V_{ref}} \quad (29)$$

#### 8.2.2.9.1 Minimum Output Voltage

Due to the internal design of the TPS54623, there is a minimum output voltage limit for any given input voltage. The output voltage can never be lower than the internal voltage reference of 0.6 V. Above 0.6 V, the output voltage may be limited by the minimum controllable on time. The minimum output voltage in this case is given by Equation 30.

$$V_{outmin} = \text{Ontimemin} \cdot F_{smax} (V_{inmax} + I_{outmin} (R_{DS2min} - R_{DS1min})) - I_{outmin} (R_L + R_{DS2min})$$

where

- $V_{outmin}$  = minimum achievable output voltage
- $\text{Ontimemin}$  = minimum controllable on-time (135 nsec maximum)
- $F_{smax}$  = maximum switching frequency including tolerance
- $V_{inmax}$  = maximum input voltage
- $I_{outmin}$  = minimum load current
- $R_{DS1min}$  = minimum high side MOSFET on resistance (36-32 mΩ typical)
- $R_{DS2min}$  = minimum low side MOSFET on resistance (19 mΩ typical)
- $R_L$  = series resistance of output inductor

### 8.2.2.10 Compensation Component Selection

There are several industry techniques used to compensate DC/DC regulators. The method presented here is easy to calculate and yields high phase margins. For most conditions, the regulator has a phase margin between 60 and 90 degrees. The method presented here ignores the effects of the slope compensation that is internal to the TPS54623. Since the slope compensation is ignored, the actual crossover frequency is usually lower than the cross over frequency used in the calculations.

First, the modulator pole,  $f_{pmod}$ , and the esr zero,  $f_{zmod}$  must be calculated using Equation 31 and Equation 32. For  $C_{out}$ , use a derated value of 75 μF. use Equation 33 and Equation 34 to estimate a starting point for the closed loop crossover frequency  $f_{co}$ . Then the required compensation components may be derived. For this design example,  $f_{pmod}$  is 3.86 kHz and  $f_{zmod}$  is 707.4 kHz. Equation 33 is the geometric mean of the modulator pole and the esr zero and Equation 34 is the geometric mean of the modulator pole and one half the switching frequency. Use a frequency near the lower of these two values as the intended crossover frequency  $f_{co}$ . In this case Equation 33 yields 52.2 kHz and Equation 34 yields 30.4 kHz. The lower value is 30.4 kHz. A slightly higher frequency of 30 kHz is chosen as the intended crossover frequency.

$$f_{pmod} = \frac{I_{out}}{2 \cdot \pi \cdot V_{out} \cdot C_{out}} \quad (31)$$

$$f_{zmod} = \frac{1}{2 \cdot \pi \cdot \text{RESR} \cdot C_{out}} \quad (32)$$

$$f_{co} = \sqrt{f_{pmod} \cdot f_{zmod}} \quad (33)$$

$$f_{co} = \sqrt{f_{pmod} \cdot \frac{f_{sw}}{2}} \tag{34}$$

Now the compensation components can be calculated. First calculate the value for R2 which sets the gain of the compensated network at the crossover frequency. Use Equation 35 to determine the value of R2.

$$R4 = \frac{2\pi \cdot f_c \cdot V_{out} \cdot C_{out}}{g_{m_{ea}} \cdot V_{ref} \cdot g_{m_{ps}}} \tag{35}$$

Next calculate the value of C3. Together with R2, C3 places a compensation zero at the modulator pole frequency. Equation 36 to determine the value of C3.

$$C4 = \frac{V_{out} \cdot C_{out}}{I_{out} \cdot R4} \tag{36}$$

Using Equation 35 and Equation 36 the standard values for R4 and C4 are 3.74 kΩ and 0.01 μF.

An additional high frequency pole can be used if necessary by adding a capacitor in parallel with the series combination of R4 and C4. The pole frequency can be placed at the ESR zero frequency of the output capacitor as given by Equation 12. Use Equation 37 to calculate the required capacitor value for C5.

$$C5 = \frac{RESR \cdot C_{out}}{R4} \tag{37}$$

### 8.2.3 Application Curves

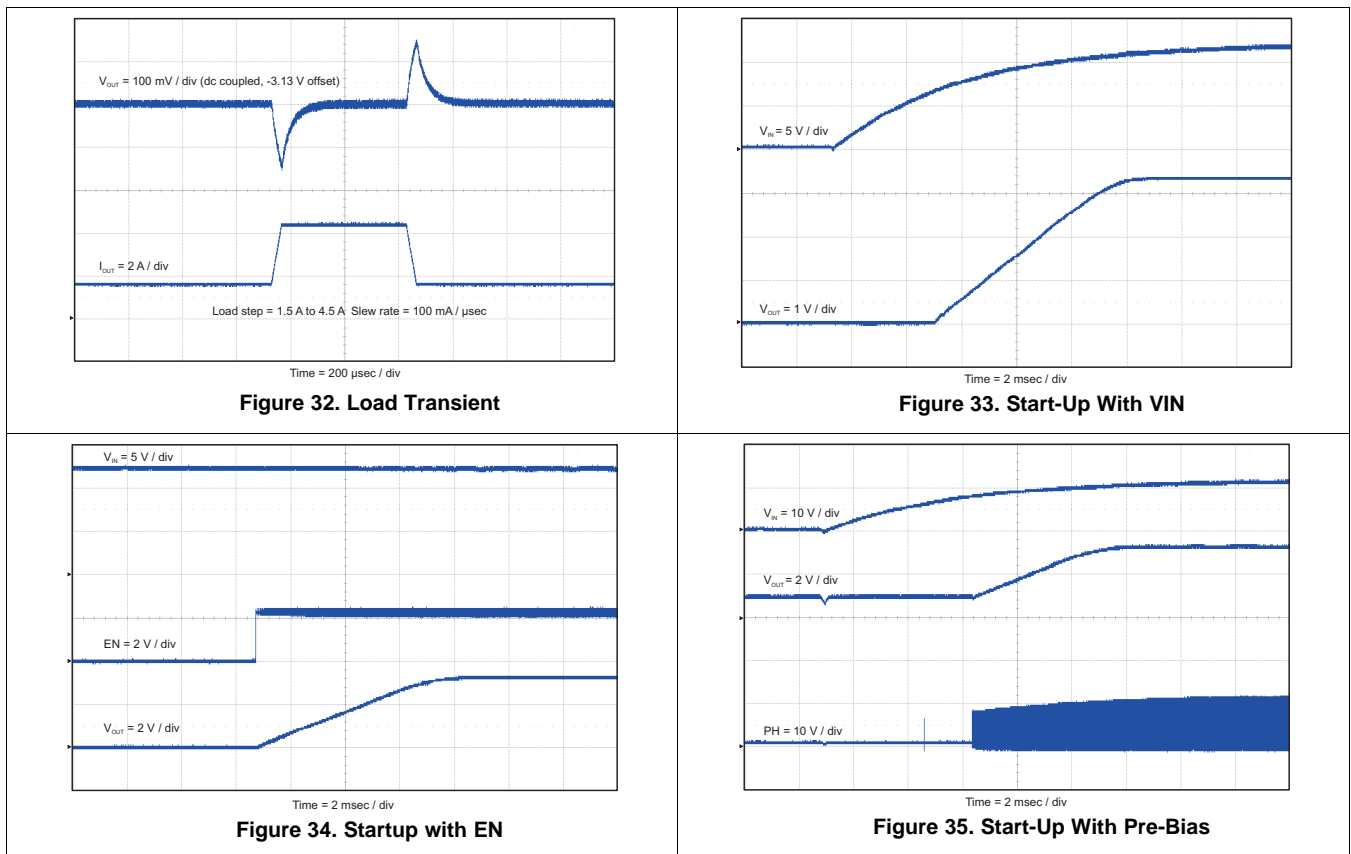

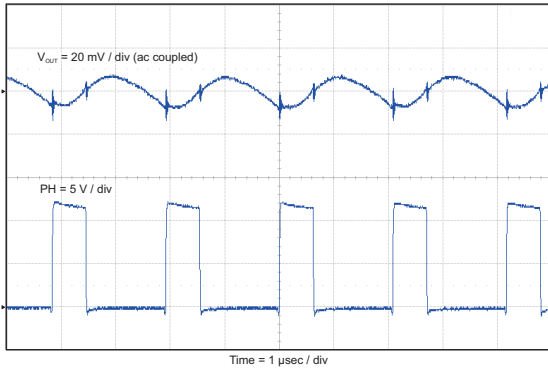

Figure 36. Output Voltage Ripple With Full Load

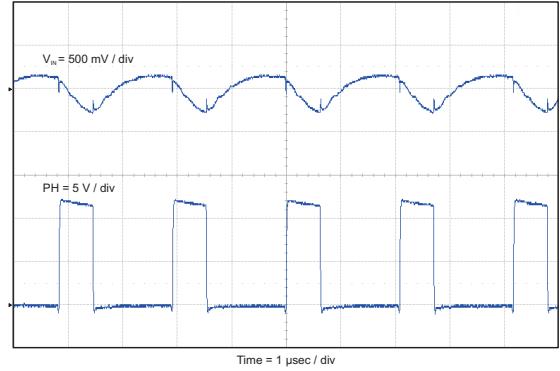

Figure 37. Input Voltage Ripple with Full Load

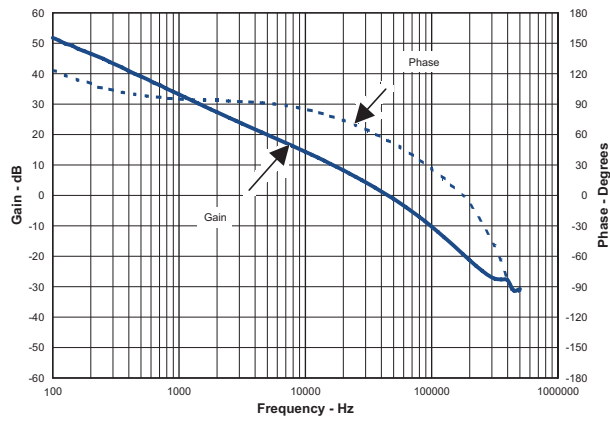

Figure 38. Closed Loop Response

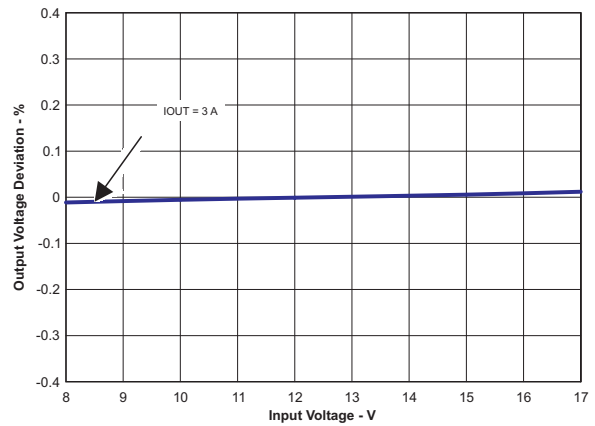

Figure 39. Line Regulation

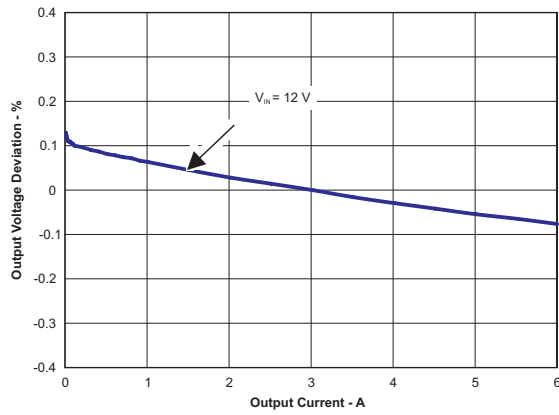

Figure 40. Load Regulation

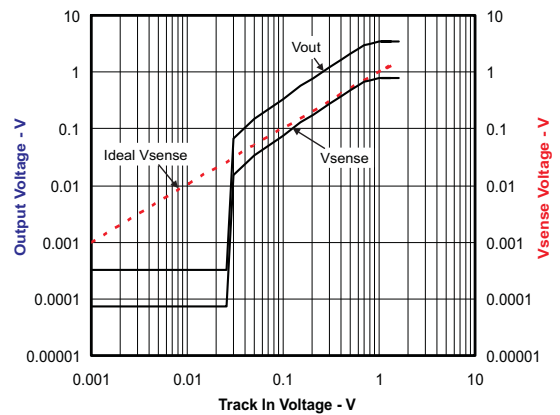

Figure 41. Tracking Performance

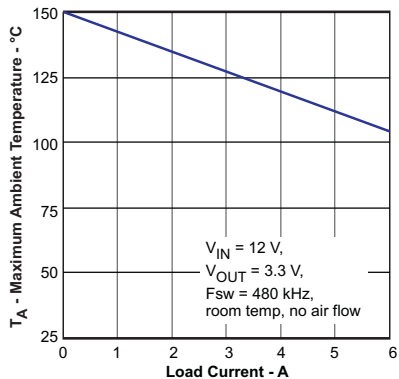

Figure 42. Maximum Ambient Temperature vs Load Current

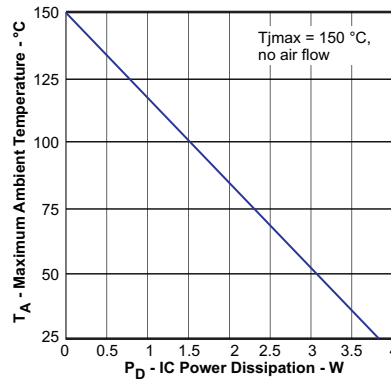

Figure 43. Maximum Ambient Temperature vs IC Power Dissipation

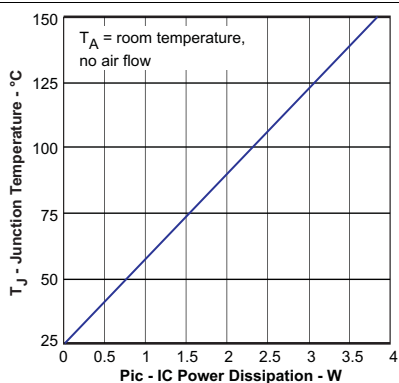

Figure 44. Junction Temperature vs IC Power Dissipation

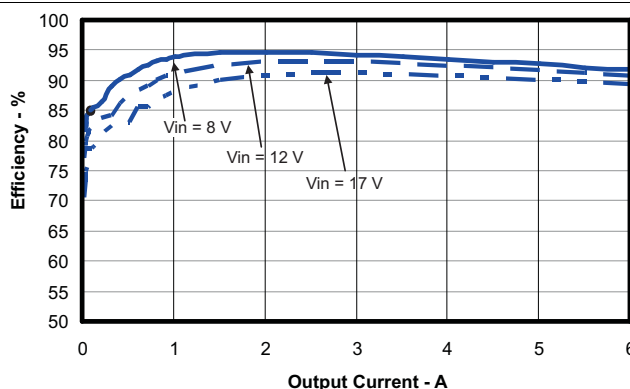

Figure 45. Efficiency vs Load Current

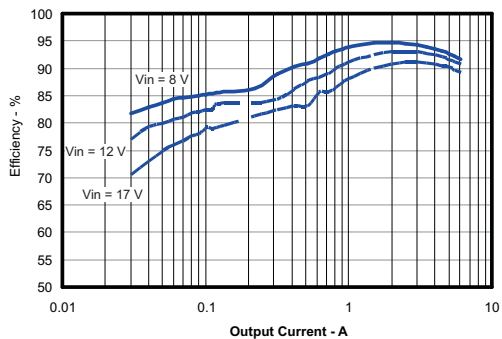

Figure 46. Efficiency vs Output Current

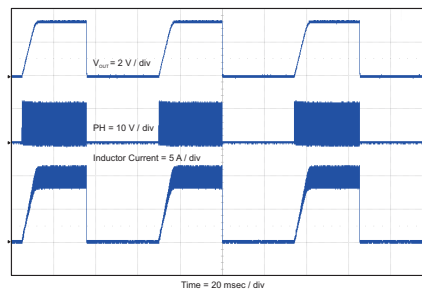

Figure 47. TPS54623 Hiccup Mode Current Limit



## 9 Power Supply Recommendations

The device is designed to operate from an input-voltage supply range between 4.5 V and 17 V when the VIN and PVIN pins are connected to the same voltage source. This input supply should be well regulated. If the input supply is located more than a few inches from the converter, additional bulk capacitance may be required in addition to the ceramic bypass capacitors. An electrolytic capacitor with a value of 100  $\mu$ F is a typical choice.

TPS54623 can be operated with independent voltage sources for the VIN and PVIN inputs. The voltage range for the VIN pin is 4.5 to 17 V. The voltage range for PVIN is 1.7 V to 17 V. Both of these input supplies should be well regulated. If the input supply is located more than a few inches from the converter, additional bulk capacitance may be required in addition to the ceramic bypass capacitors for PVIN.

## 10 Layout

### 10.1 Layout Guidelines

Layout is a critical portion of good power supply design. See [Figure 48](#) for a PCB layout example. The top layer contains the main power traces for VIN, VOUT, and VPHASE. Also on the top layer are connections for the remaining pins of the TPS54623 and a large top side area filled with ground. The top layer ground area should be connected to the internal ground layer(s) using vias at the input bypass capacitor, the output filter capacitor and directly under the TPS54623 device to provide a thermal path from the exposed thermal pad land to ground. The GND pin should be tied directly to the power pad under the IC and the power pad. For operation at full rated load, the top side ground area together with the internal ground plane, must provide adequate heat dissipating area. There are several signals paths that conduct fast changing currents or voltages that can interact with stray inductance or parasitic capacitance to generate noise or degrade the power supplies performance. To help eliminate these problems, the PVIN pin must be bypassed to ground with a low ESR ceramic bypass capacitor with X5R or X7R dielectric. Care should be taken to minimize the loop area formed by the bypass capacitor connections, the PVIN pins, and the ground connections. The VIN pin must also be bypassed to ground using a low ESR ceramic capacitor with X5R or X7R dielectric. Make sure to connect this capacitor to the quiet analog ground trace rather than the power ground trace of the PVIN bypass capacitor. Since the PH connection is the switching node, the output inductor should be located close to the PH pins, and the area of the PCB conductor minimized to prevent excessive capacitive coupling. The output filter capacitor ground should use the same power ground trace as the PVIN input bypass capacitor. Try to minimize this conductor length while maintaining adequate width. The small signal components should be grounded to the analog ground path as shown. The RT/CLK pin is sensitive to noise so the RT resistor should be located as close as possible to the IC and routed with minimal lengths of trace. The additional external components can be placed approximately as shown. It may be possible to obtain acceptable performance with alternate PCB layouts, however this layout has been shown to produce good results and is meant as a guideline.

Land pattern and stencil information is provided in the data sheet addendum. The dimension and outline information is for the standard RHL (S-PVQFN-N14) package. There may be slight differences between the provided data and actual lead frame used on the TPS54623RHL package.

#### 10.1.1 Estimated Circuit Area

The estimated printed circuit board area for the components used in the design of [Figure 31](#) is 0.58 in<sup>2</sup> (374 mm<sup>2</sup>). This area does not include test points or connectors.



## 10.2 Layout Examples

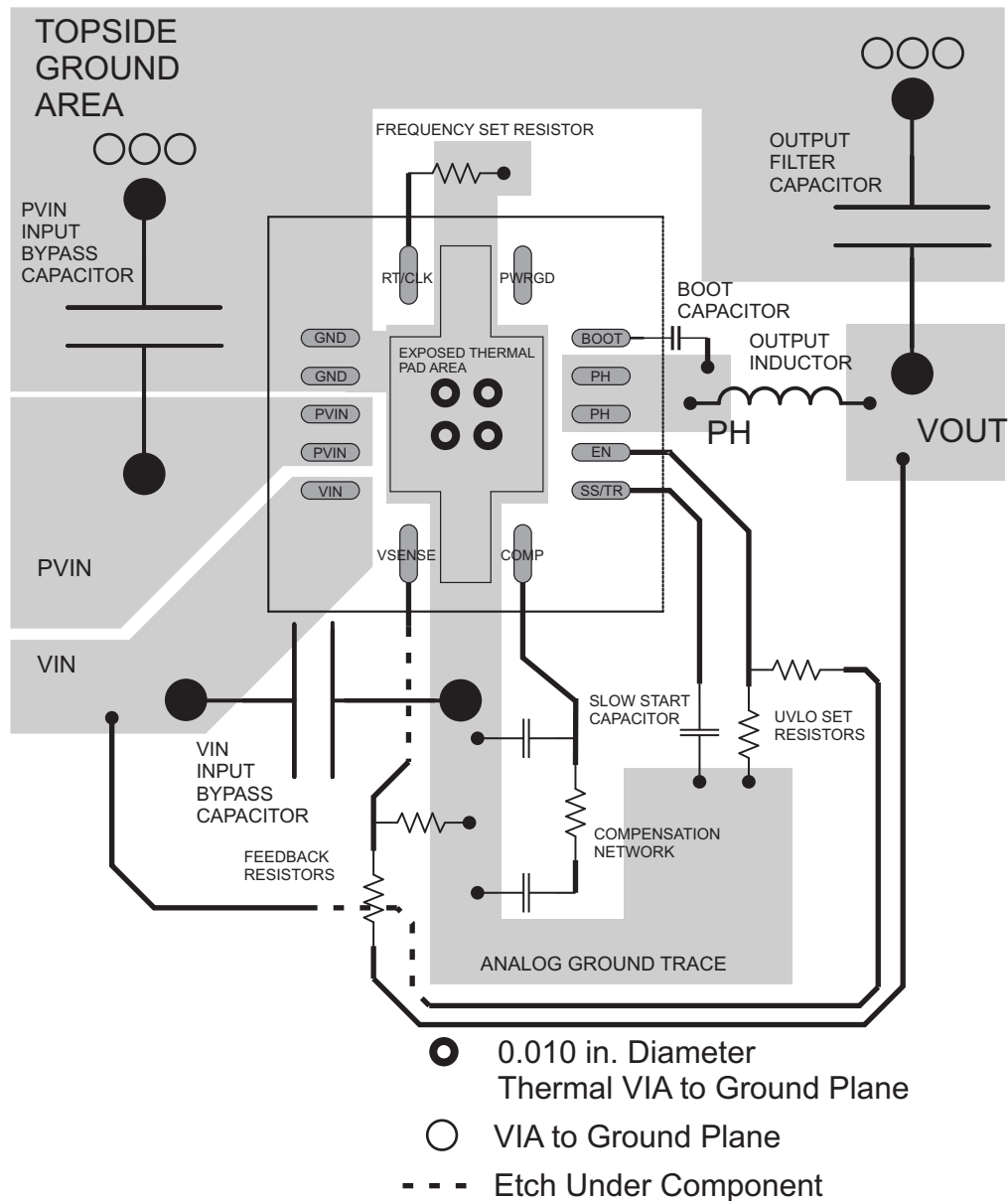
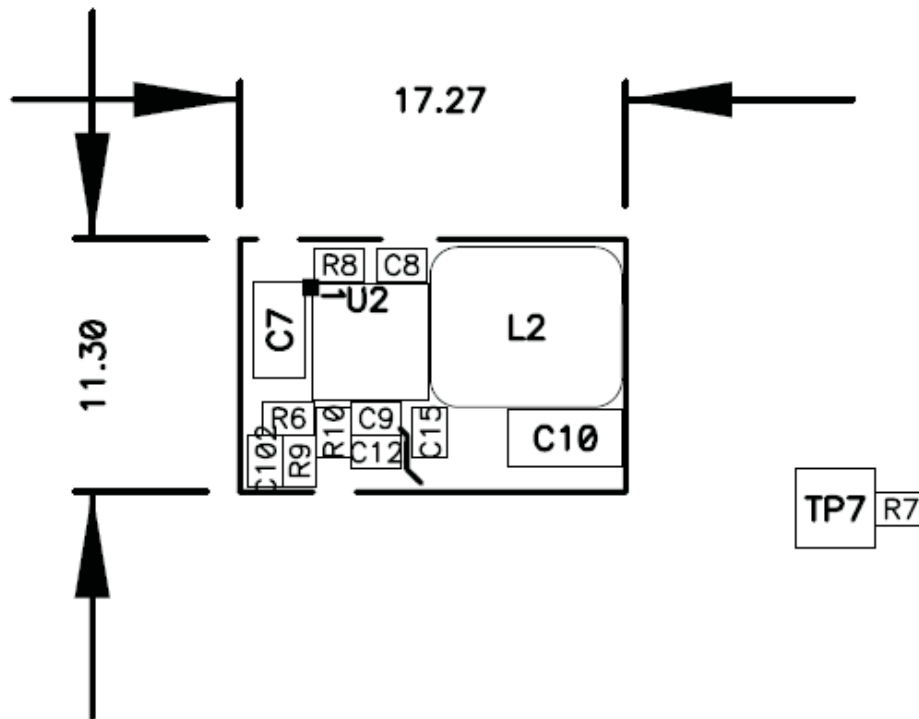

Figure 48. PCB Layout

**Layout Examples (continued)**



**Figure 49. Ultra-Small PCB Layout Using TPS54623 (PMP4854-2)**

## 11 デバイスおよびドキュメントのサポート

### 11.1 デバイス・サポート

#### 11.1.1 デベロッパー・ネットワークの製品に関する免責事項

デベロッパー・ネットワークの製品またはサービスに関するTIの出版物は、単独またはTIの製品、サービスと一緒に提供される場合に関係なく、デベロッパー・ネットワークの製品またはサービスの適合性に関する是認、デベロッパー・ネットワークの製品またはサービスの是認の表明を意味するものではありません。

#### 11.1.2 開発サポート

SWIFTのドキュメントについては、<http://www.ti.com/swift>をご覧ください。

#### 11.1.3 WEBENCH®ツールによるカスタム設計

[ここをクリック](#)すると、WEBENCH® Power Designerにより、TPS54623デバイスを使用するカスタム設計を作成できます。

1. 最初に、入力電圧( $V_{IN}$ )、出力電圧( $V_{OUT}$ )、出力電流( $I_{OUT}$ )の要件を入力します。
2. オプティマイザのダイヤルを使用して、効率、占有面積、コストなどの主要なパラメータについて設計を最適化します。
3. 生成された設計を、テキサス・インスツルメンツが提供する他のソリューションと比較します。

WEBENCH Power Designerでは、カスタマイズされた回路図と部品リストを、リアルタイムの価格と部品の在庫情報と併せて参照できます。

ほとんどの場合、次の操作を実行可能です。

- 電気的なシミュレーションを実行し、重要な波形と回路の性能を確認する。
- 熱シミュレーションを実行し、基板の熱特性を把握する。
- カスタマイズされた回路図やレイアウトを、一般的なCADフォーマットでエクスポートする。
- 設計のレポートをPDFで印刷し、同僚と設計を共有する。

WEBENCHツールの詳細は、[www.ti.com/WEBENCH](http://www.ti.com/WEBENCH)でご覧になれます。

### 11.2 ドキュメントのサポート

#### 11.2.1 関連資料

関連資料については、以下を参照してください。

- 『電流モード降圧コンバータ用のタイプIII補償回路の設計』
- 設計カリキュレータ、SLVC219

#### 11.3 ドキュメントの更新通知を受け取る方法

ドキュメントの更新についての通知を受け取るには、[ti.com](http://ti.com)のデバイス製品フォルダを開いてください。右上の隅にある「通知を受け取る」をクリックして登録すると、変更されたすべての製品情報に関するダイジェストを毎週受け取れます。変更の詳細については、修正されたドキュメントに含まれている改訂履歴をご覧ください。

#### 11.4 コミュニティ・リソース

The following links connect to TI community resources. Linked contents are provided "AS IS" by the respective contributors. They do not constitute TI specifications and do not necessarily reflect TI's views; see TI's [Terms of Use](#).

**TI E2E™オンライン・コミュニティ** TIのE2E ( *Engineer-to-Engineer* ) コミュニティ。エンジニア間の共同作業を促進するために開設されたものです。e2e.ti.comでは、他のエンジニアに質問し、知識を共有し、アイデアを検討して、問題解決に役立てることができます。

**設計サポート** TIの設計サポート役に立つE2Eフォーラムや、設計サポート・ツールをすばやく見つけることができます。技術サポート用の連絡先情報も参照できます。

#### 11.5 商標

E2E is a trademark of Texas Instruments.

WEBENCH is a registered trademark of Texas Instruments.

## 11.5 商標 (continued)

All other trademarks are the property of their respective owners.

## 11.6 静電気放電に関する注意事項



すべての集積回路は、適切なESD保護方法を用いて、取扱いと保存を行うようにして下さい。

静電気放電はわずかな性能の低下から完全なデバイスの故障に至るまで、様々な損傷を与えます。高精度の集積回路は、損傷に対して敏感であり、極めてわずかなパラメータの変化により、デバイスに規定された仕様に適合しなくなる場合があります。

## 11.7 Glossary

[SLYZ022](#) — *TI Glossary*.

This glossary lists and explains terms, acronyms, and definitions.

## 12 メカニカル、パッケージ、および注文情報

以降のページには、メカニカル、パッケージ、および注文に関する情報が記載されています。この情報は、そのデバイスについて利用可能な最新のデータです。このデータは予告なく変更されることがあり、ドキュメントが改訂される場合もあります。本データシートのブラウザ版を使用されている場合は、画面左側の説明をご覧ください。

**PACKAGING INFORMATION**

Orderable Device	Status (1)	Package Type	Package Drawing	Pins	Package Qty	Eco Plan (2)	Lead finish/ Ball material (6)	MSL Peak Temp (3)	Op Temp (°C)	Device Marking (4/5)	Samples
TPS54623RHLLR	ACTIVE	VQFN	RHL	14	3000	RoHS & Green	NIPDAU	Level-1-260C-UNLIM	-40 to 150	54623	<a href="#">Samples</a>
TPS54623RHLLT	ACTIVE	VQFN	RHL	14	250	RoHS & Green	NIPDAU	Level-1-260C-UNLIM	-40 to 150	54623	<a href="#">Samples</a>

(1) The marketing status values are defined as follows:

**ACTIVE:** Product device recommended for new designs.

**LIFEBUY:** TI has announced that the device will be discontinued, and a lifetime-buy period is in effect.

**NRND:** Not recommended for new designs. Device is in production to support existing customers, but TI does not recommend using this part in a new design.

**PREVIEW:** Device has been announced but is not in production. Samples may or may not be available.

**OBSOLETE:** TI has discontinued the production of the device.

(2) **RoHS:** TI defines "RoHS" to mean semiconductor products that are compliant with the current EU RoHS requirements for all 10 RoHS substances, including the requirement that RoHS substance do not exceed 0.1% by weight in homogeneous materials. Where designed to be soldered at high temperatures, "RoHS" products are suitable for use in specified lead-free processes. TI may reference these types of products as "Pb-Free".

**RoHS Exempt:** TI defines "RoHS Exempt" to mean products that contain lead but are compliant with EU RoHS pursuant to a specific EU RoHS exemption.

**Green:** TI defines "Green" to mean the content of Chlorine (Cl) and Bromine (Br) based flame retardants meet JS709B low halogen requirements of <=1000ppm threshold. Antimony trioxide based flame retardants must also meet the <=1000ppm threshold requirement.

(3) MSL, Peak Temp. - The Moisture Sensitivity Level rating according to the JEDEC industry standard classifications, and peak solder temperature.

(4) There may be additional marking, which relates to the logo, the lot trace code information, or the environmental category on the device.

(5) Multiple Device Markings will be inside parentheses. Only one Device Marking contained in parentheses and separated by a "~" will appear on a device. If a line is indented then it is a continuation of the previous line and the two combined represent the entire Device Marking for that device.

(6) Lead finish/Ball material - Orderable Devices may have multiple material finish options. Finish options are separated by a vertical ruled line. Lead finish/Ball material values may wrap to two lines if the finish value exceeds the maximum column width.

**Important Information and Disclaimer:**The information provided on this page represents TI's knowledge and belief as of the date that it is provided. TI bases its knowledge and belief on information provided by third parties, and makes no representation or warranty as to the accuracy of such information. Efforts are underway to better integrate information from third parties. TI has taken and continues to take reasonable steps to provide representative and accurate information but may not have conducted destructive testing or chemical analysis on incoming materials and chemicals. TI and TI suppliers consider certain information to be proprietary, and thus CAS numbers and other limited information may not be available for release.

In no event shall TI's liability arising out of such information exceed the total purchase price of the TI part(s) at issue in this document sold by TI to Customer on an annual basis.



**TAPE AND REEL INFORMATION**

**QUADRANT ASSIGNMENTS FOR PIN 1 ORIENTATION IN TAPE**

\*All dimensions are nominal

Device	Package Type	Package Drawing	Pins	SPQ	Reel Diameter (mm)	Reel Width W1 (mm)	A0 (mm)	B0 (mm)	K0 (mm)	P1 (mm)	W (mm)	Pin1 Quadrant
TPS54623RHLR	VQFN	RHL	14	3000	330.0	12.4	3.75	3.75	1.15	8.0	12.0	Q2
TPS54623RHLT	VQFN	RHL	14	250	180.0	12.4	3.75	3.75	1.15	8.0	12.0	Q2

**TAPE AND REEL BOX DIMENSIONS**

\*All dimensions are nominal

Device	Package Type	Package Drawing	Pins	SPQ	Length (mm)	Width (mm)	Height (mm)
TPS54623RHRLR	VQFN	RHL	14	3000	335.0	335.0	25.0
TPS54623RHILT	VQFN	RHL	14	250	182.0	182.0	20.0



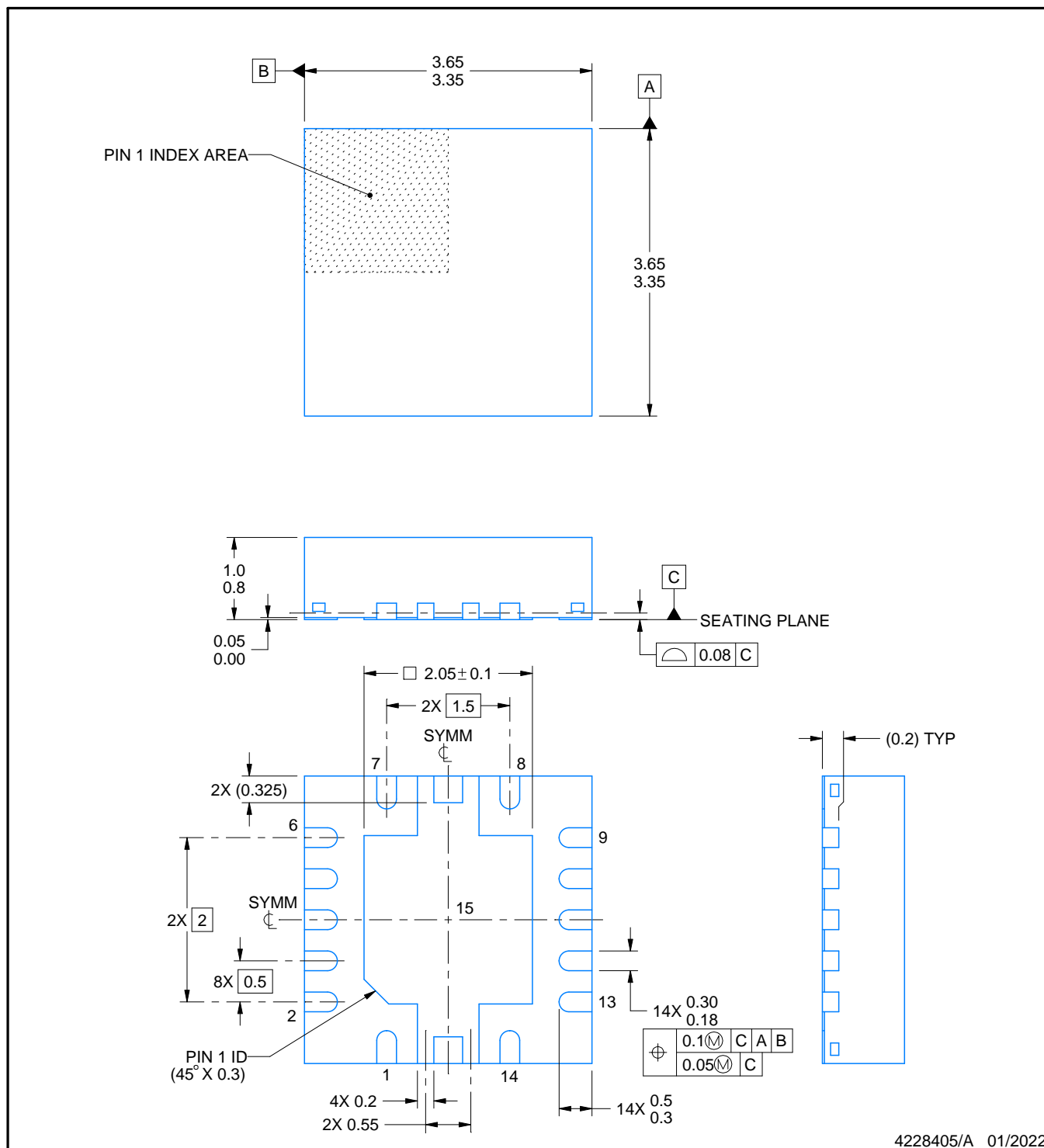

4228405/A 01/2022

**NOTES:**

1. All linear dimensions are in millimeters. Any dimensions in parenthesis are for reference only. Dimensioning and tolerancing per ASME Y14.5M.
2. This drawing is subject to change without notice.
3. The package thermal pad must be soldered to the printed circuit board for thermal and mechanical performance.

# EXAMPLE BOARD LAYOUT

RHL0014A

VQFN - 1 mm max height

PLASTIC QUAD FLATPACK - NO LEAD

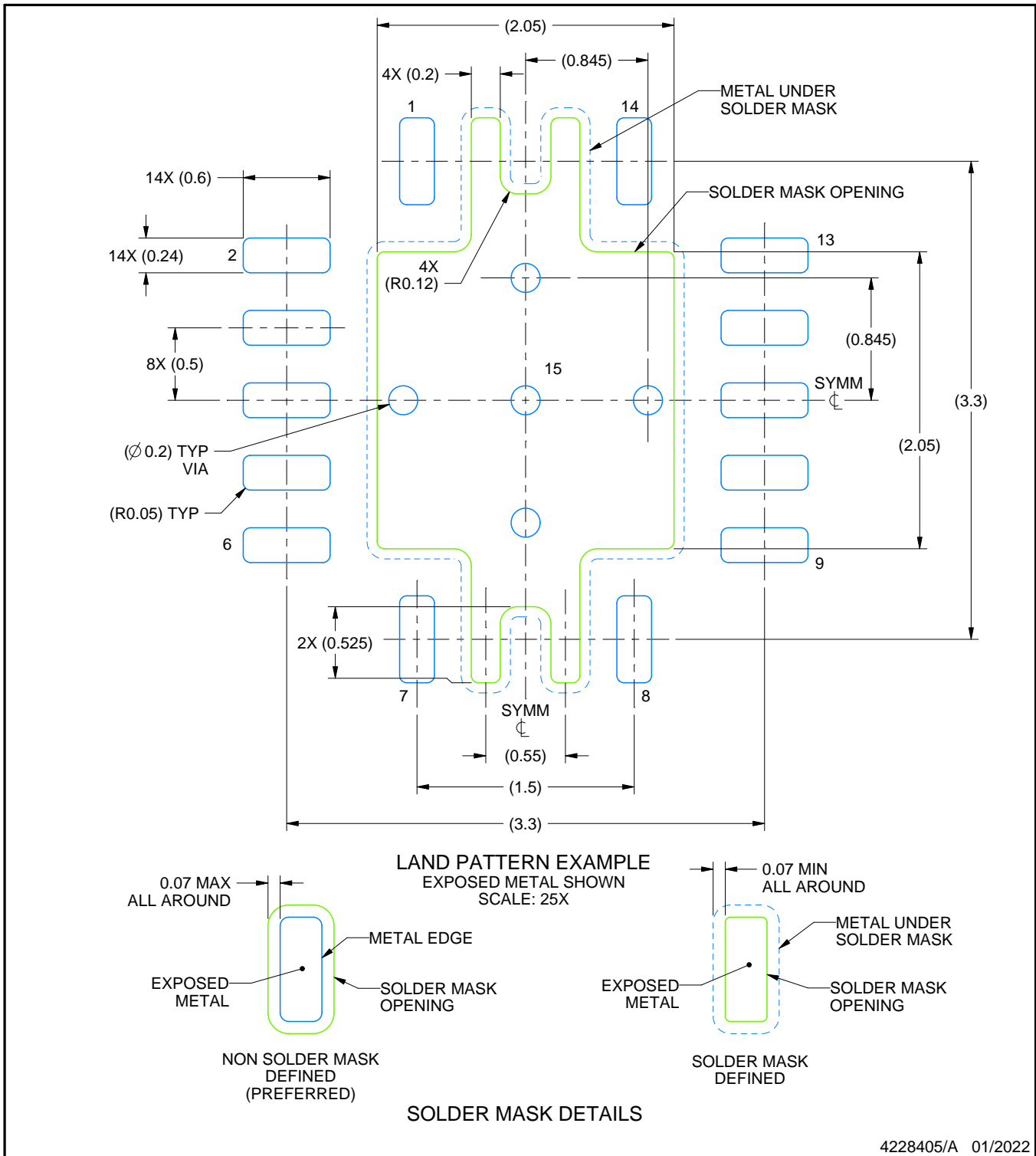

4228405/A 01/2022

NOTES: (continued)

- This package is designed to be soldered to a thermal pad on the board. For more information, see Texas Instruments literature number SLUA271 ([www.ti.com/lit/sluea271](http://www.ti.com/lit/sluea271)).
- Solder mask tolerances between and around signal pads can vary based on board fabrication site.
- Vias are optional depending on application, refer to device data sheet. If any vias are implemented, refer to their locations shown on this view. It is recommended that vias under paste be filled, plugged or tented.

# EXAMPLE STENCIL DESIGN

RHL0014A

VQFN - 1 mm max height

PLASTIC QUAD FLATPACK - NO LEAD

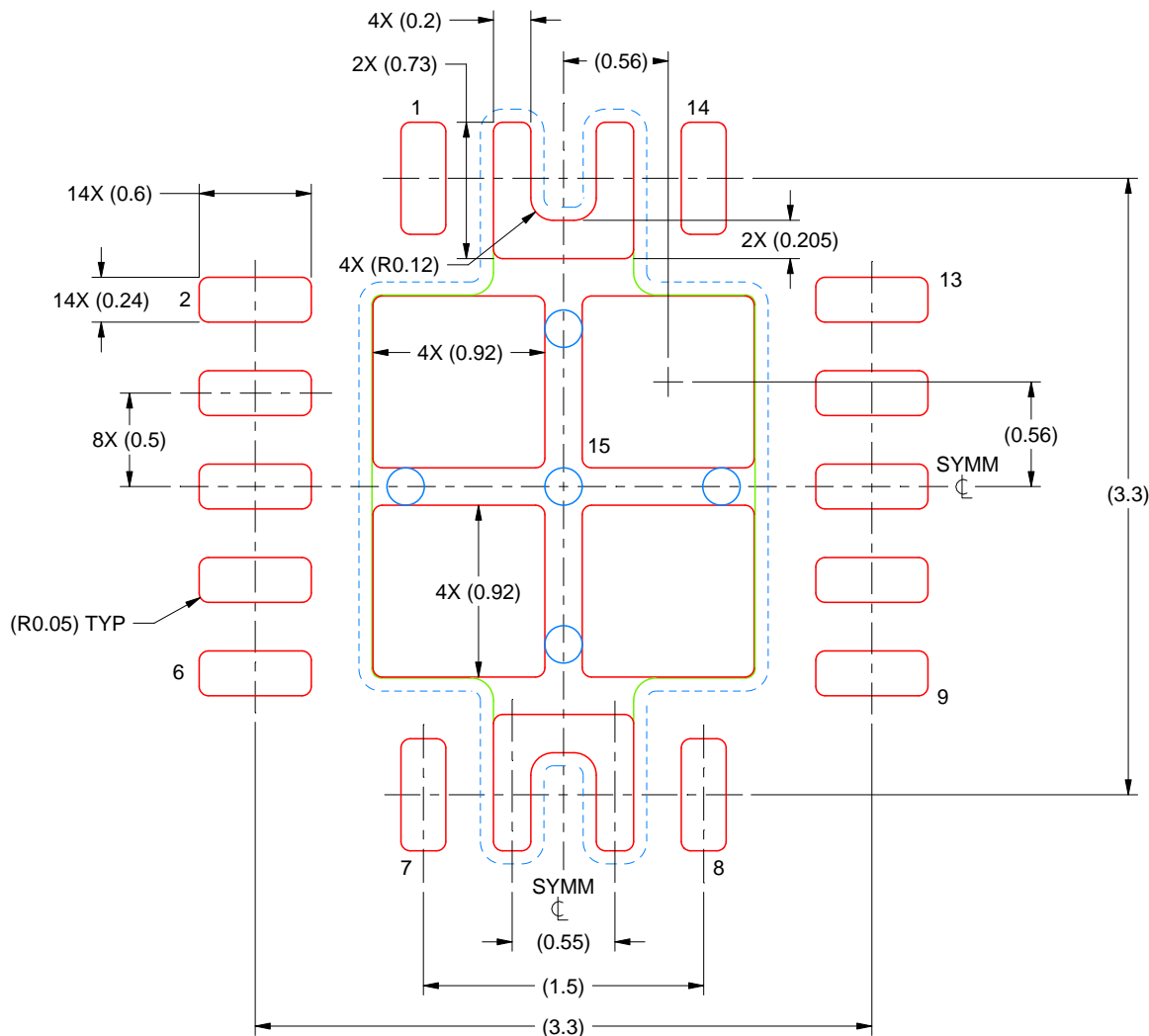

**SOLDER PASTE EXAMPLE**  
 BASED ON 0.125 mm THICK STENCIL

EXPOSED PAD  
 79% PRINTED COVERAGE BY AREA  
 SCALE: 25X

4228405/A 01/2022

NOTES: (continued)

7. Laser cutting apertures with trapezoidal walls and rounded corners may offer better paste release. IPC-7525 may have alternate design recommendations.

## 重要なお知らせと免責事項

TI は、技術データと信頼性データ (データシートを含みます)、設計リソース (リファレンス・デザインを含みます)、アプリケーションや設計に関する各種アドバイス、Web ツール、安全性情報、その他のリソースを、欠陥が存在する可能性のある「現状のまま」提供しており、商品性および特定目的に対する適合性の黙示保証、第三者の知的財産権の非侵害保証を含むいかなる保証も、明示的または黙示的にかかわらず拒否します。

これらのリソースは、TI 製品を使用する設計の経験を積んだ開発者への提供を意図したものです。(1) お客様のアプリケーションに適した TI 製品の選定、(2) お客様のアプリケーションの設計、検証、試験、(3) お客様のアプリケーションに該当する各種規格や、その他のあらゆる安全性、セキュリティ、規制、または他の要件への確実な適合に関する責任を、お客様のみが単独で負うものとし、

上記の各種リソースは、予告なく変更される可能性があります。これらのリソースは、リソースで説明されている TI 製品を使用するアプリケーションの開発の目的でのみ、TI はその使用をお客様に許諾します。これらのリソースに関して、他の目的で複製することや掲載することは禁止されています。TI や第三者の知的財産権のライセンスが付与されている訳ではありません。お客様は、これらのリソースを自身で使用した結果発生するあらゆる申し立て、損害、費用、損失、責任について、TI およびその代理人を完全に補償するものとし、TI は一切の責任を拒否します。

TI の製品は、[TI の販売条件](#)、または [ti.com](https://www.ti.com) やかかる TI 製品の関連資料などのいずれかを通じて提供する適用可能な条項の下で提供されています。TI がこれらのリソースを提供することは、適用される TI の保証または他の保証の放棄の拡大や変更を意味するものではありません。

お客様がいかなる追加条項または代替条項を提案した場合でも、TI はそれらに異議を唱え、拒否します。

郵送先住所 : Texas Instruments, Post Office Box 655303, Dallas, Texas 75265  
Copyright © 2023, Texas Instruments Incorporated