

TI Designs: TIDA-01437

IO-Linkインターフェイス付きRGB信号ライトのリファレンス・デザイン



概要

このリファレンス・デザインでは、工場現場、およびより複雑な産業用プロセス・オートメーションで使用される、20個のLEDを使用した5セグメントのLEDスマート・スタックライトを実装します。スタックライトの制御とステータス情報の読み出し用に、IO-Linkインターフェイスが実装されています。このデザインは低消費電力で、IO-Linkインターフェイスからの電力で動作できます。

この信号ライトのリファレンス・デザインは、RGB LEDドライバの消費電力を30%低減し、輝度制御の範囲を拡大する方法を示しています。輝度の自動制御により、周囲の明るさに応じて輝度が調節されます。このリファレンス・デザインでは、単純なPWMを使用してスイッチング・レギュレータの出力電圧を変更し、動的なヘッドルーム制御を実装しています。

リソース

TIDA-01437	デザイン・フォルダ
TIOL111	プロダクト・フォルダ
MSP430FR5969	プロダクト・フォルダ
TLC5971	プロダクト・フォルダ
LM5166	プロダクト・フォルダ
OPT3001	プロダクト・フォルダ
HDC1080	プロダクト・フォルダ
CSD13202	プロダクト・フォルダ
TVS3300	プロダクト・フォルダ
TPS54062	プロダクト・フォルダ



[E2Eエキスパートに質問](#)

特長

- 柔軟で制御しやすいRGB LEDタワー・ライト設計
- デモ、温度、湿度、スタックライトなど各種の実装モード
- IO-Linkで完全に制御可能
- 20個のRGB LEDで構成される5つのセグメント
- リニアRGB LEDドライバの動的なヘッドルーム制御により、消費電力を30%削減
- 輝度の自動制御

アプリケーション

- ファクトリ・オートメーション/制御
- ビルディング・オートメーション

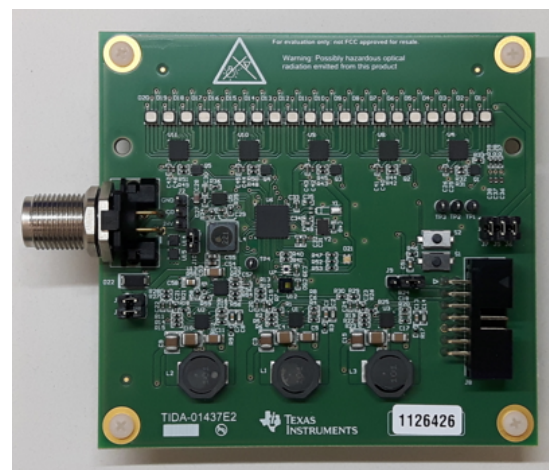

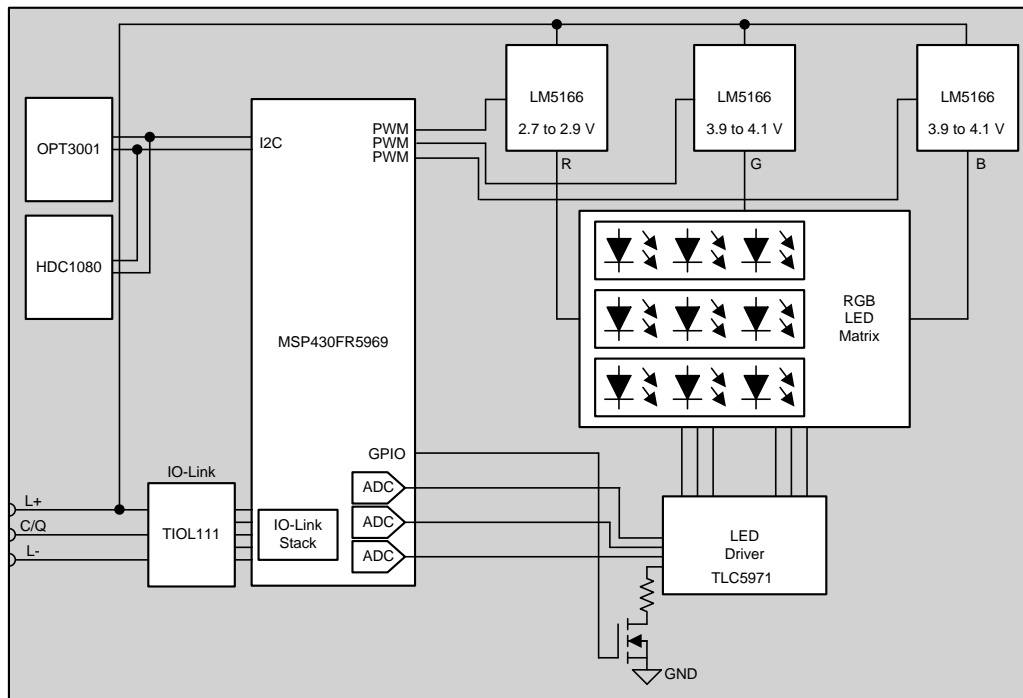

Copyright © 2017, Texas Instruments Incorporated



使用許可、知的財産、その他免責事項は、最終ページにあるIMPORTANT NOTICE(重要な注意事項)をご参照くださいますようお願いいたします。英語版のTI製品についての情報を翻訳したこの資料は、製品の概要を確認する目的で便宜的に提供しているものです。該当する正式な英語版の最新情報は、www.ti.comで閲覧でき、その内容が常に優先されます。TIでは翻訳の正確性および妥当性につきましては一切保証いたしません。実際の設計などの前には、必ず最新版の英語版をご参照くださいますようお願いいたします。

1 System Description

Industrial signal lights indicate the status of manufacturing equipment or the status of processes in industrial environments. These lights are often called stacklights, tower lights, or indicator lights and contain one to five difference colors. The IEC 60073 standard shows how the colors correspond to different states (see 表 1).

表 1. IEC 60073 International Color Usage

COLOR	SAFETY MEANING	CONDITION OF PROCESS
Red	Danger	Emergency or fault
Amber	Warning	Abnormal
Green	Safe	Normal
Blue	Mandatory significance	
White	No specific meaning assigned	

This reference design provides a universal stacklight option based on RGB LEDs. This option consists of one PCB implementing the whole design as shown in 図 1.

The design consists of four major parts:

- Buck regulator for LED drivers with adjustable output voltage
- LED drivers with configurable current
- IO-Link interface and MSP430FR5969 microcontroller
- Light sensor (OPT3001) and temperature and humidity sensor (HDC1080)

To power and control the design, only IO-Link is necessary. Each of the 20 RGB LEDs can be controlled individually. To keep the power dissipation low, the supply voltage for the different color LEDs is regulated for each color and can be controlled depending on the selected brightness.

The design can be configured to:

- Be a simple one-color stacklight
- Be a programmable multi color stacklight
- Be level or temperature light
- Adapt the LED brightness depending on the ambient light

1.1 Key System Specifications

表 2. Key System Specifications

PARAMETER	SPECIFICATIONS
Input voltage	$V_{IN(min)} = 20\text{ V}$
	$V_{IN(typ)} = 24\text{ V}$
	$V_{IN(max)} = 36\text{ V}$
Current consumption at 24 V	$I_{LEDs(off)} = 0.1\text{ mA}$
	$I_{LEDs(2\text{ mA})} = 30\text{ mA}$
	$I_{LEDs(20\text{ mA})} = 280\text{ mA}$
	$I_{LEDs(20\text{ mA no DHC})} = 190\text{ mA}$
Interfaces	IO-Link through Standard M12 Connector
	JTAG
LEDs	20 RGB LEDs, up to 20 mA each

2 System Overview

The stacklight reference design demonstrates how an industrial stacklight with advanced features such as dynamic headroom control and brightness control can be implemented.

2.1 Block Diagram

Figure 1 shows the overall block diagram.

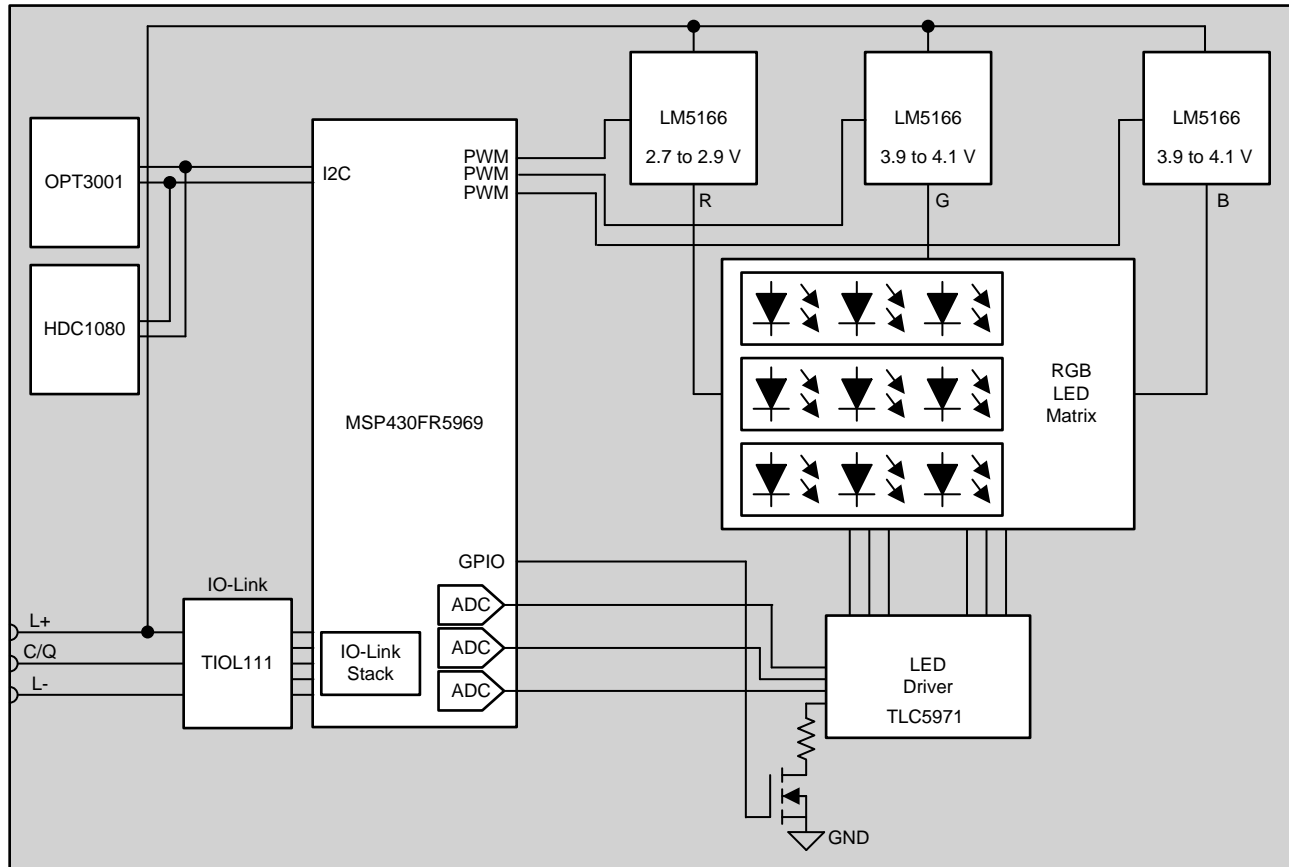

Copyright © 2017, Texas Instruments Incorporated

Figure 1. TIDA-01437 Block Diagram

2.2 Highlighted Products

This reference design features the following devices: [OPT3001](#), [HDC1080](#), [MSP430FR5969](#), [LM5166](#), [TIOL111](#), [TPS54062](#), [TVS3300](#) and [TLC5971](#).

For further details about these products, see their corresponding product folders on [TI.com](http://ti.com).

2.2.1 OPT3001

The OPT3001 is a sensor that measures the intensity of visible light. The spectral response of the sensor tightly matches the photopic response of the human eye and includes significant infrared rejection.

The OPT3001 is a single-chip lux meter, measuring the intensity of light as visible by the human eye. The precision spectral response and strong IR rejection of the device enables the OPT3001 to accurately meter the intensity of light as seen by the human eye regardless of light source. The strong IR rejection also aids in maintaining high accuracy when an industrial design calls for mounting the sensor under dark glass for aesthetics.

Key features of this device include:

- Precision optical filtering to match human eye: Rejects > 99% (typ) of IR
- Automatic full-scale setting feature simplifies software and ensures proper configuration
- Measurements: 0.01 lux to 83k lux
- 23-bit effective dynamic range with automatic gain ranging
- 12 binary-weighted full-scale range settings: < 0.2% (typ) matching between ranges
- Low operating current: 1.8 μ A (typ)
- Operating temperature range: -40°C to 85°C
- Wide power-supply range: 1.6 to 3.6 V
- 5.5-V tolerant I/O
- Flexible interrupt system

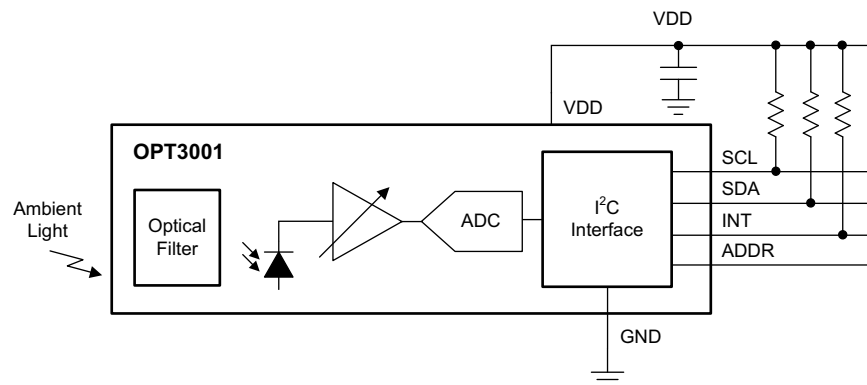

Copyright © 2017, Texas Instruments Incorporated

図 2. OPT3001 Functional Block Diagram

2.2.2 HDC1080

The HDC1080 is a digital humidity sensor with an integrated temperature sensor that provides excellent measurement accuracy at low power. The HDC1080 operates over a wide supply range and is a low-cost, low-power alternative to competitive solutions in a wide range of common applications. The humidity and temperature sensors are factory calibrated.

Figure 3 shows the functional block diagram of the HDC1080 device.

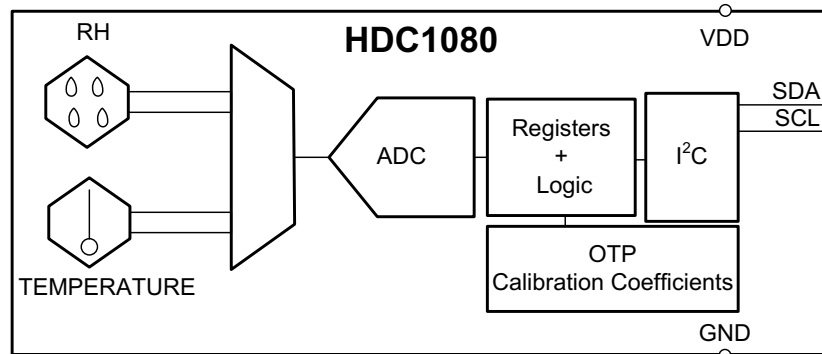

Copyright © 2017, Texas Instruments Incorporated

Figure 3. HDC1080 Functional Block Diagram

2.2.3 MSP430FR5969

The Texas Instruments MSP430™ family of ultra-low-power microcontrollers consists of several devices that feature different combinations of peripherals targeted for various applications. The architecture, combined with extensive low-power modes, is optimized to achieve extended battery life in portable measurement applications. The MSP430 features a powerful 16-bit RISC CPU, 16-bit registers, and constant generators that contribute to maximum code efficiency. The digitally controlled oscillator (DCO) allows the MCU to wake up from low-power modes to active mode typically in less than 10 μ s.

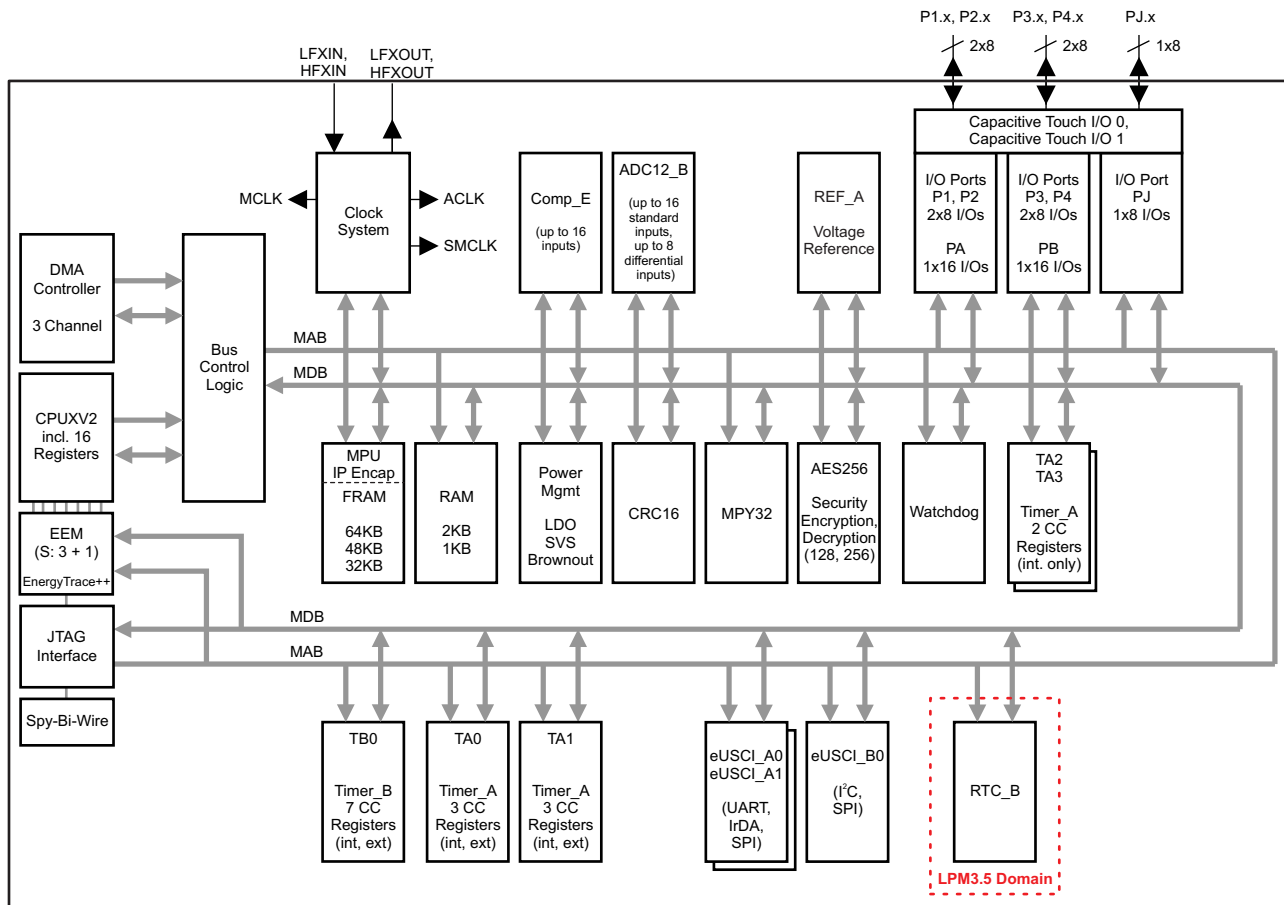

Copyright © 2016, Texas Instruments Incorporated

図 4. MSP430FR5969 Block Diagram

Key features of this device include:

- Embedded microcontroller:
 - 16-bit RISC architecture up to a 16-MHz clock
 - Wide supply voltage range: 1.8 to 3.6 V
- Optimized ultra-low-power modes:
 - Active mode: Approximately 100 μ A/MHz
 - Standby (LPM3 with VLO): 0.4 μ A (typical)
 - Real-time clock (LPM3.5): 0.25 μ A (typical)
 - Shutdown (LPM4.5): 0.02 μ A (typical)
- Ultra-low-power ferroelectric RAM (FRAM):
 - Up to 64kB of nonvolatile memory
 - Ultra-low-power writes
 - Fast write at 125 ns per word (64kB in 4 ms)
 - Unified memory = Program + Data + Storage in one single space
 - 10^{15} write cycle endurance

- Radiation resistant and nonmagnetic
- Intelligent digital peripherals:
 - 32-bit hardware multiplier (MPY)
 - Three-channel internal DMA
 - Real-time clock (RTC) with calendar and alarm functions
 - Five 16-bit timers with up to seven capture/compare registers each
 - 16-bit cyclic redundancy checker (CRC)
- High-performance analog:
 - 16-channel analog comparator
 - 12-bit analog-to-digital converter (ADC) with internal reference and sample-and-hold and up to 16 external input channels
- Multifunction input/output ports:
 - All pins support capacitive touch capability with no need for external components
 - Accessible bit-, byte-, and word-wise (in pairs)
 - Edge-selectable wake from LPM on all ports
 - Programmable pullup and pulldown on all ports
- Code security and encryption:
 - 128- or 256-bit AES security encryption and decryption coprocessor
 - Random number seed for random number generation algorithms
- Enhanced serial communication:
 - eUSCI_A0 and eUSCI_A1 support:
 - UART with automatic baud-rate detection
 - IrDA encode and decode
 - SPI at rates up to 10 Mbps
 - eUSCI_B0 supports:
 - I²C with multiple slave addressing
 - SPI at rates up to 8 Mbps
 - Hardware UART and I²C bootstrap loader (BSL)
- Flexible clock system:
 - Fixed-frequency DCO with 10 selectable factory-trimmed frequencies
 - Low-power low-frequency internal clock source (VLO)
 - 32-kHz crystals (LFXT)
 - High-frequency crystals (HFXT)

For complete module descriptions, see the [MSP430FR59xx user's guide](#).

2.2.4 LM5166

The LM5166 regulator is an easy-to-use synchronous buck DC/DC converter that operates from a 3- to 65-V supply voltage. The device is intended for step-down conversions from 5-V, 12-V, 24-V, and 48-V unregulated, semi-regulated and fully-regulated supply rails. With integrated high-side and low-side power MOSFETs, the LM5166 delivers up to 500-mA DC load current with exceptional efficiency and ultra-low input quiescent current in a very small solution size.

Designed for simple implementation, a choice of operating modes offers flexibility to optimize its usage according to the target application. Fixed-frequency, constant on-time (COT) operation with discontinuous conduction mode (DCM) at light loads is ideal for low-noise, high-current, fast transient load requirements. Alternatively, pulse frequency modulation (PFM) mode achieves ultra-high, light-load efficiency performance. Control loop compensation is not required with either operating mode, reducing design time and external component count.

The LM5166 incorporates other features for comprehensive system requirements, including an open-drain Power Good circuit for power-rail sequencing and fault reporting, internally-fixed or externally-adjustable soft-start, monotonic startup into pre-biased loads, precision enable with customizable hysteresis for programmable line undervoltage lockout (UVLO), and thermal shutdown with automatic recovery. These features enable a flexible and easy-to-use platform for a wide range of applications. The pin arrangement is designed for simple and optimized PCB layout, requiring only a few external components.

The high-side P-channel MOSFET buck switch operates at 100% duty cycle in low dropout voltage conditions and does not require a bootstrap capacitor for gate drive.

In this reference design, the LM5166 serves to step down the voltage from the IO-Link interface to the desired LED voltages.

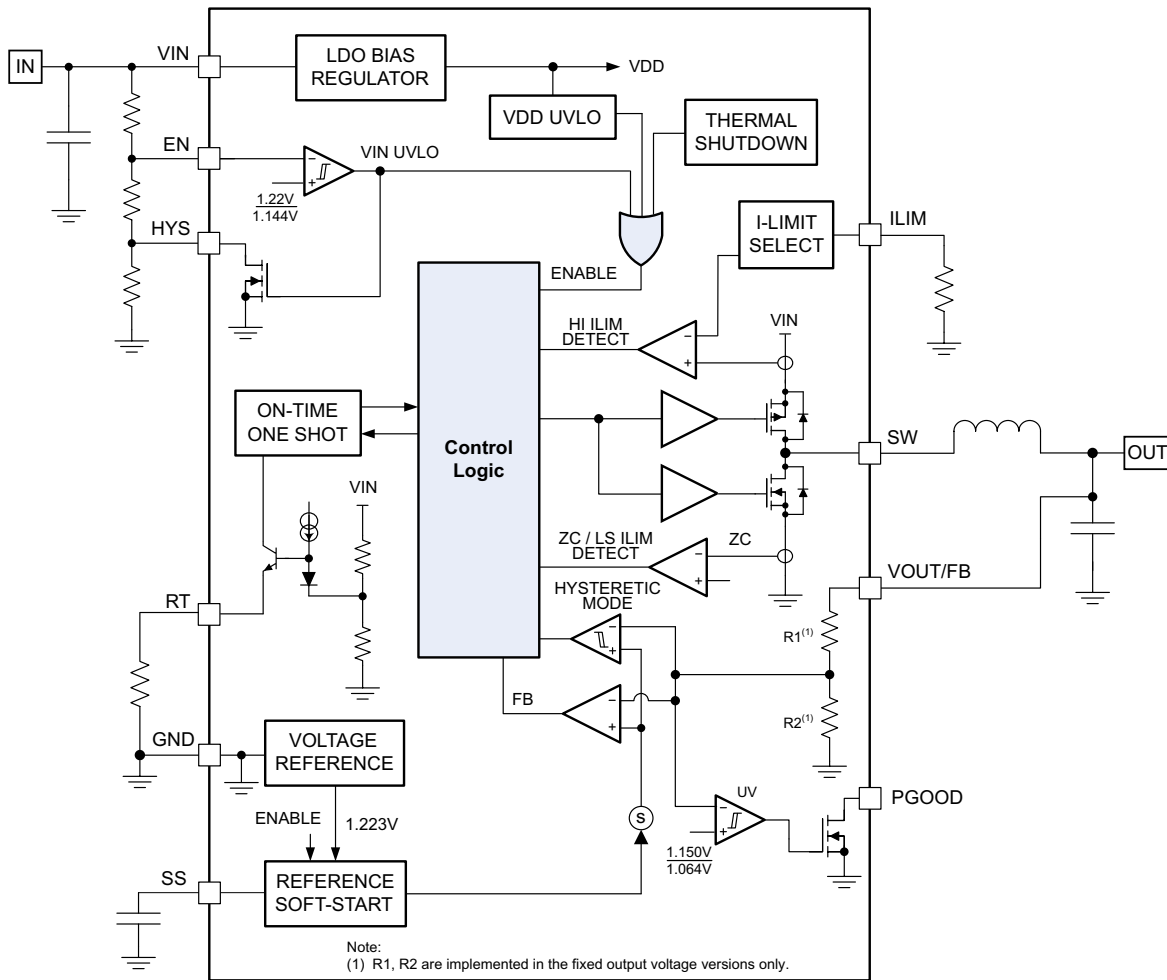

Copyright © 2016, Texas Instruments Incorporated

図 5. Block Diagram of LM5166

2.2.5 TPS54062

The TPS54062 device is a 60-V, 50-mA, synchronous step-down converter with integrated high-side and low-side MOSFETs. Current mode control provides simple external compensation and flexible component selection.

The switching frequency of 100 to 400 kHz allows for efficiency and size optimization when selecting the output filter components. The switching frequency is adjusted using a resistor-to-ground on the RT/CLK pin. The device has an internal phase lock loop (PLL) on the RT/CLK pin that is used to synchronize the power switch turnon to a falling edge of an external system clock.

The integrated 1.5-Ω high-side MOSFET and 0.8-Ω low-side MOSFET allows for high efficiency power supply designs capable of delivering 50-mA of continuous current to a load.

The TPS54062 reduces the external component count by integrating the boot recharge diode. The bias voltage for the integrated high-side MOSFET is supplied by a capacitor on the BOOT to PH pin. The boot capacitor voltage is monitored by an UVLO circuit and turns the high-side MOSFET off when the boot voltage falls below a preset threshold. The TPS54062 can operate at high duty cycles because of the boot UVLO. The output voltage can be stepped down to as low as the 0.8-V reference.

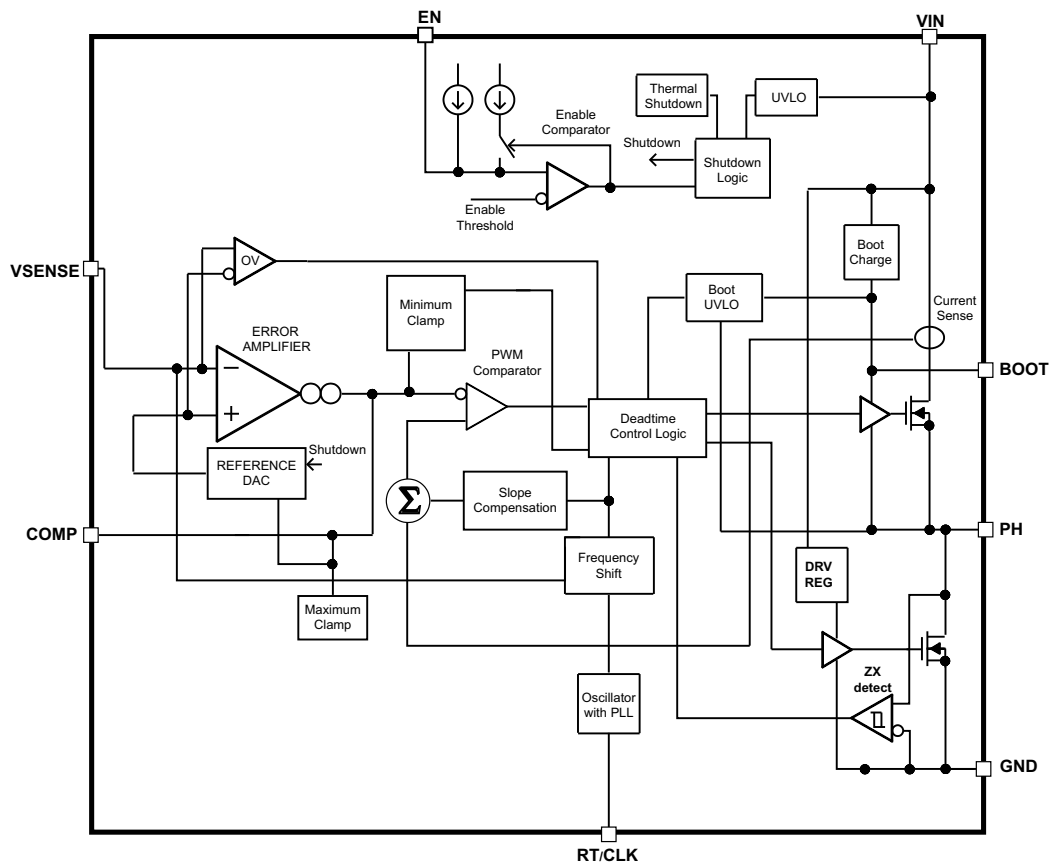

Copyright © 2016, Texas Instruments Incorporated

図 6. Block Diagram of TPS54062

This reference design uses the TPS54062 to supply 3.3 V to the MSP430FR5969 from the 24-V main voltage.

2.2.6 TVS3300

The TVS3300 is a precision clamp that handles 35 A of 8/20- μ s surge pulse. The flat clamping feature helps keep the clamping voltage very low to keep the downstream circuits from being stressed. The flat clamping feature can also help end-equipment designers save cost by opening up the possibility to use lower-cost lower voltage tolerant downstream devices. The TVS3300 has minimal leakage under the standoff voltage of 33 V, making it an ideal candidate, but not limited to for majority of factory and process automation applications. IEC 61000-4-2 and IEC 61000-4-4 ratings make it a robust protection solution for ESD and EFT events. A wide ambient temperature range of -40°C to 125°C makes it a good candidate for most applications. Compact packages enable it to be used in small devices and save board area.

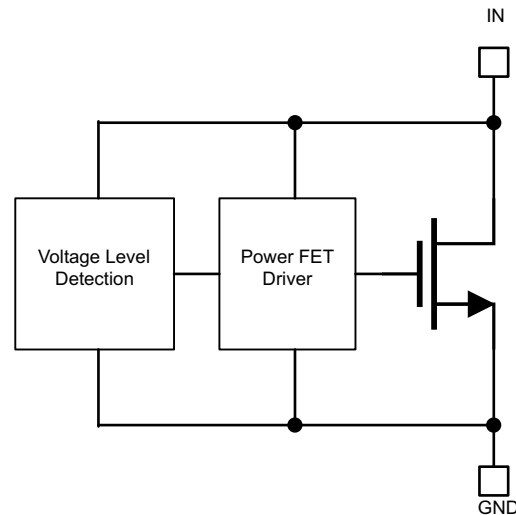

Copyright © 2017, Texas Instruments Incorporated

图 7. TVS3300 Block Diagram

This reference design uses the TVS3300 to protect against bidirectional overvoltage.

2.2.7 TIOL111

The robust TIOL111 family of transceivers implements the IO-Link interface for industrial point-to-point communication. When a device is connected to an IO-Link master through a three-wire interface, the master can initiate communication and exchange data with the remote node while the TIOL111 acts as a complete physical layer for the communication.

These devices are capable of withstanding up to 1 kV (500 Ω) of IEC 61000-4-5 surge and feature integrated reverse polarity protection.

A simple pin programmable interface allows for easy interfacing to the controller circuits. The output current limit can be configured using an external resistor.

Fault reporting and internal protection functions are provided for undervoltage, short-circuit current, and overtemperature.



図 8. TIOL111 Functional Block Diagram

2.2.8 TLC5971

The TLC5971 device is a 12-channel, constant-current sink driver. Each output channel has individually adjustable currents with 65,536 pulse-width modulation (PWM) grayscale (GS) steps. Each color group can be controlled by 128 constant-current sink steps with the global brightness control (BC) function. GS control and BC are accessible through a two-wire signal interface. The maximum current value for each channel is set by a single external resistor. All constant-current outputs are turned off when the integrated circuit is in an overtemperature condition. 9 shows the functional block diagram of the TLC5971 device.

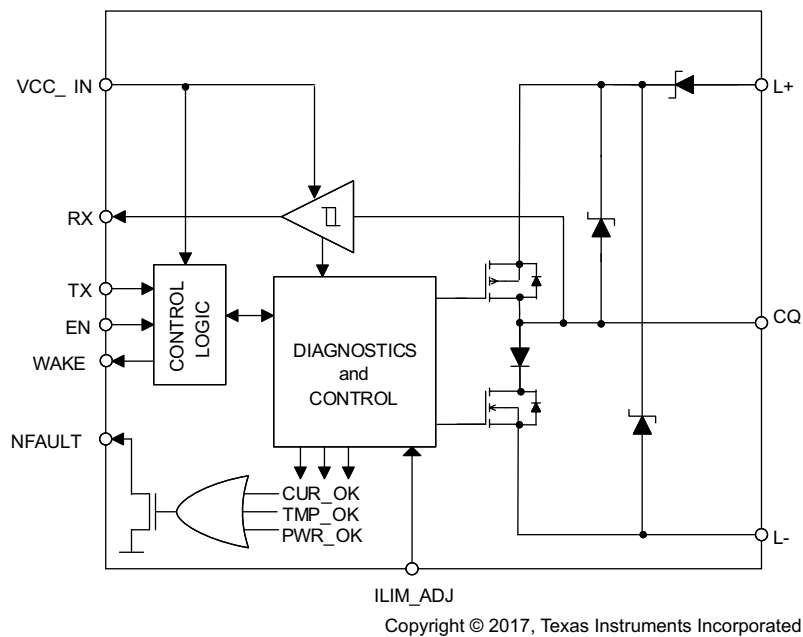
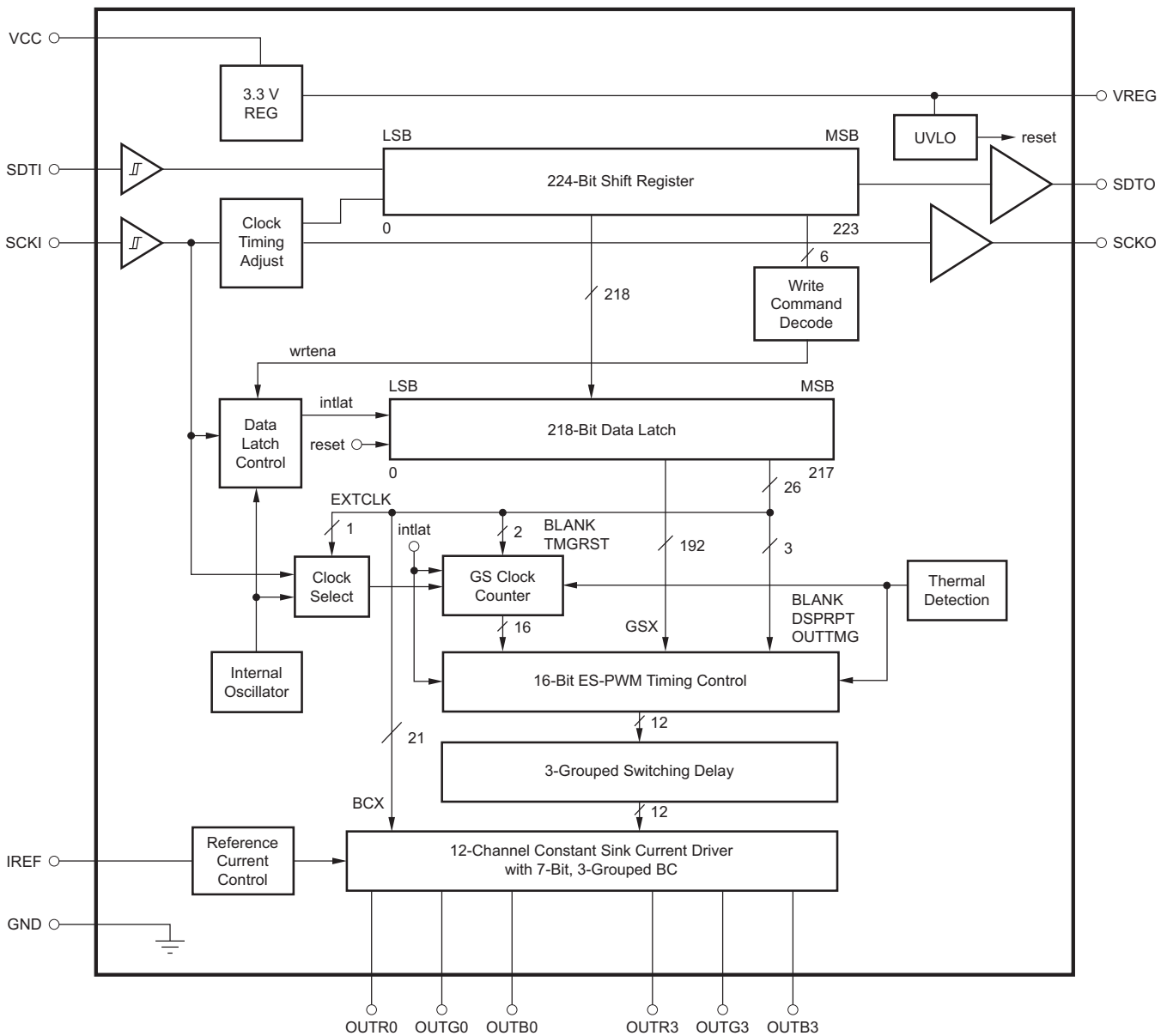

9. TLC5971 Functional Block Diagram

2.3 System Design Theory

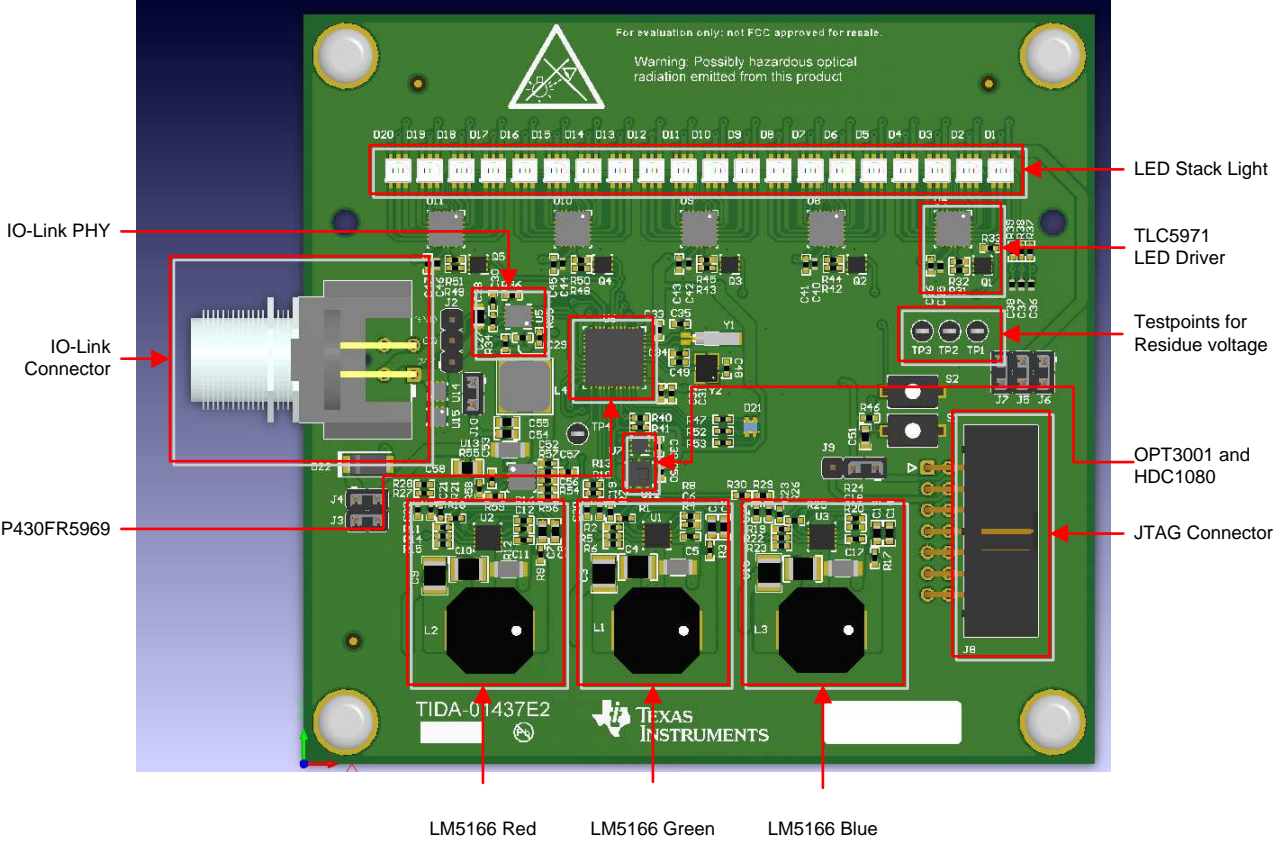
This reference design can be separated into different subsystems.  10 shows the PCB and the major parts of the design.

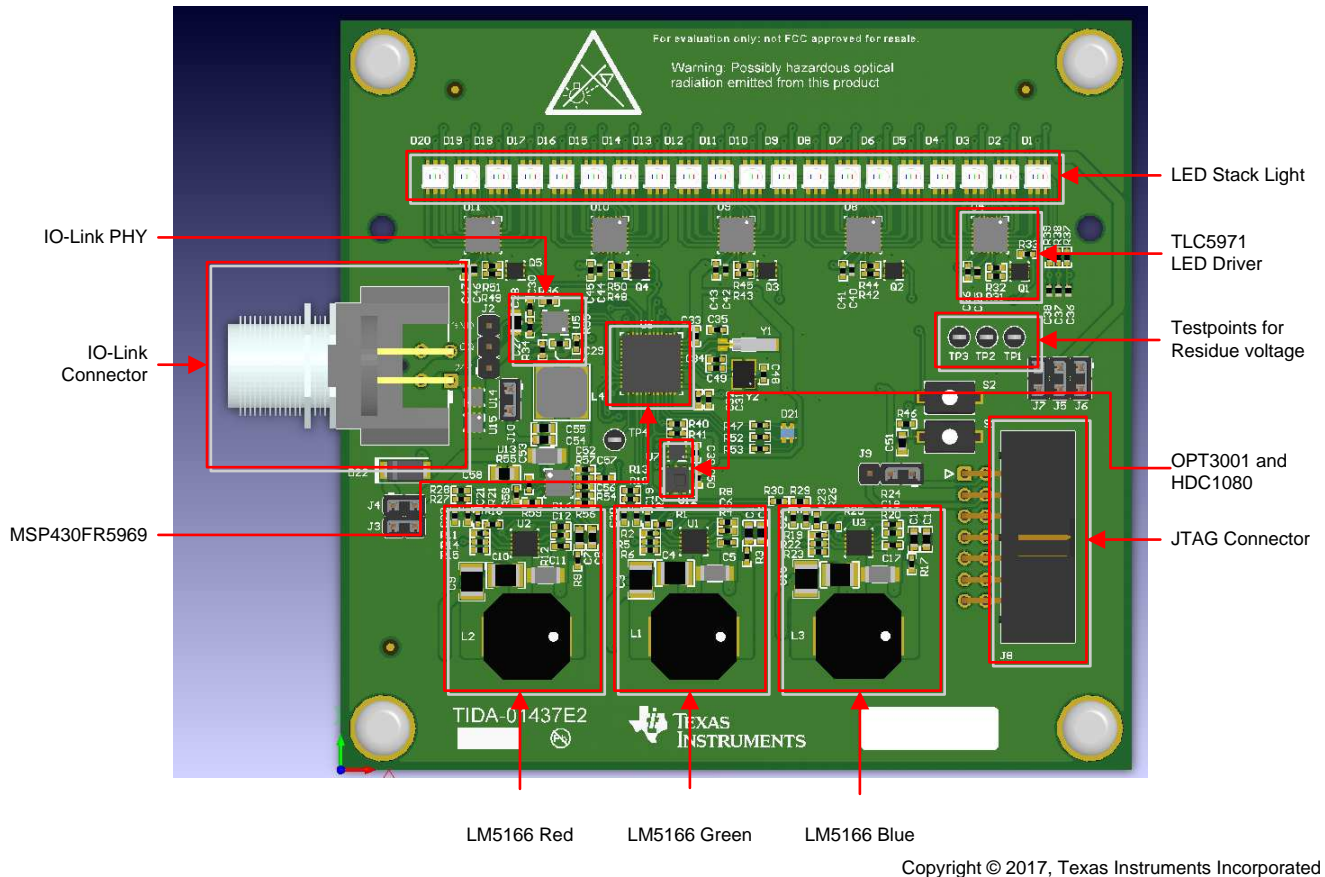

Copyright © 2017, Texas Instruments Incorporated

 10. Subsystems of Stacklight Reference Design

Each section of interest is discussed in the following subsections. Moreover, the software controlling the stacklight is explained in 2.3.6.

2.3.1 Power Supply

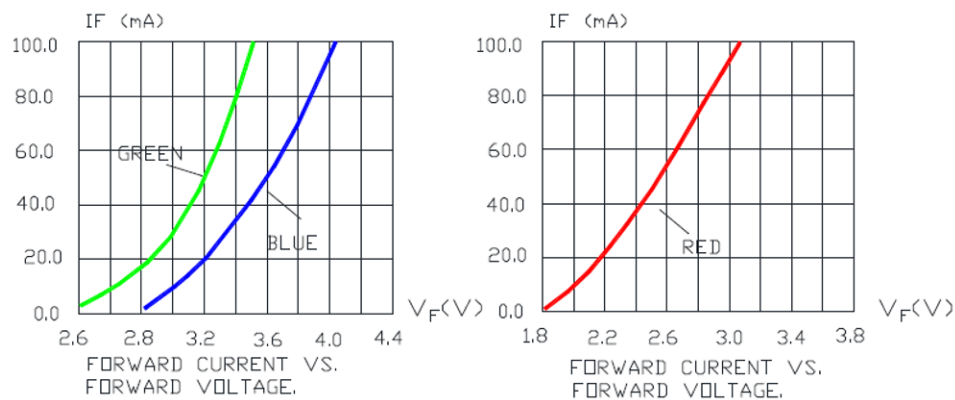

 11. Typical LED Forward Voltage of Cree CLY6D-FKC [1]

Figure 11 shows the voltage of the different colored LEDs in an RGB LED. The voltage is different for each color and depends on the current. Especially when using a large amount of LEDs, one can use different supply voltages for the LED driver to reduce the power dissipation of the chip.

Using one supply for all LEDs (for example, using an LED voltage of 5 V and a current of 20 mA) leads to a power consumption of:

$$4 \times ((5 \text{ V} - 2.85 \text{ V}) \times 20 \text{ mA} + (5 \text{ V} - 3.2 \text{ V}) \times 20 \text{ mA} + (5 \text{ V} - 2.2 \text{ V}) \times 20 \text{ mA}) = 540 \text{ mW} \quad (1)$$

Per the TLC5971 LED driver, up to 540 mW must be dissipated. This reference design uses five of them, resulting in a maximum dissipation of 2.7 W. Increasing the current increases the power dissipation further.

To reduce the dissipation, the voltage for the different colors can be reduced to a value just above the LED forward voltage plus the residue voltage necessary for the TLC5971.

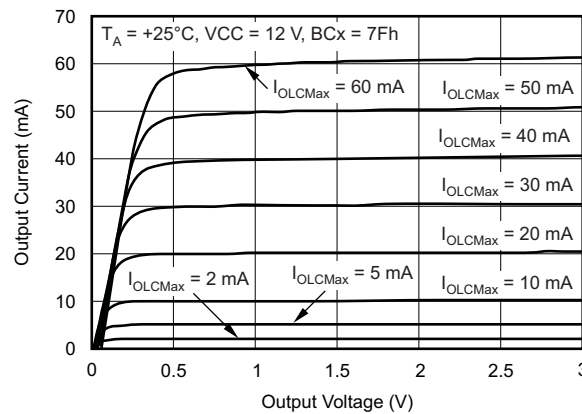

Figure 12. Residue Voltage of TLC5971

The residue voltage necessary for the LED driver can be found in the [device datasheet](#). In this case, the necessary voltage can be seen in Figure 12. In this example, the residue voltage for 20 mA is about 0.4 V. So for the different LEDs, a voltage of 2.85 V + 0.4 V = 3.25 V; 3.6 V and 2.6 V are enough. This voltage reduces the power dissipation to:

$$0.4 \text{ V} \times 20 \text{ mA} \times 12 = 96 \text{ mW} \quad (2)$$

Especially when the input current or the total power dissipation is limited, this solution is preferred.

This reference design uses five LED drivers so a reduction of more than 2 W can be achieved based on these design considerations.

In most cases, the LED current can be adjusted, so for the residue voltage and the LEDs, a range has to be considered and designed for the worst case. This adjustment might increase the power dissipation in certain cases.

2.3.1.1 LM5166 LED Power Design

This reference design uses the LM5166, which is suitable for this design because of its current capability and wide input voltage range. The design can operate in COT and PFM mode. The mode can be chosen depending on the design considerations. In this case, COT III is chosen because of the lower output ripple and high efficiency. PFM mode is preferable when a small footprint is desired or if the efficiency at very light loads must be high.

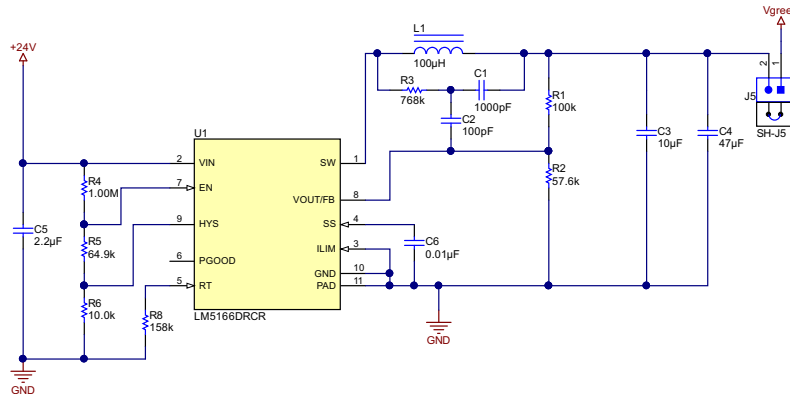

Copyright © 2017, Texas Instruments Incorporated

図 13. Schematic of LM5166 Voltage Regulator

The switching frequency is set to 200 kHz as a trade-off between inductor size and switching loss. The calculation of the timing resistor is shown in 式 3. An output voltage of 5.5 V is assumed for the calculation. When lowering the output voltage with the same resistor, the switching frequency is lower. The next standard value for this resistor of 158 kΩ is chosen.

$$R_8 = \frac{R_{RT} [k\Omega]}{V_{Out} [V] \cdot f_{Sw} [kHz]} \cdot 10^4 \cdot 1.75 = \frac{5.5 \cdot 200}{158 \cdot 1.75} = 157.1 \text{ k}\Omega \quad (3)$$

For the feedback network, the values are determined in a first step for a static output voltage and later on optimized by simulation to fit for the desired output voltage range.

By adjusting the voltage for the LED driver depending on the LED current, the reduction of power dissipation can be achieved. In this reference design, the voltage of a switching regulator is set by a microcontroller using a simple PWM signal.

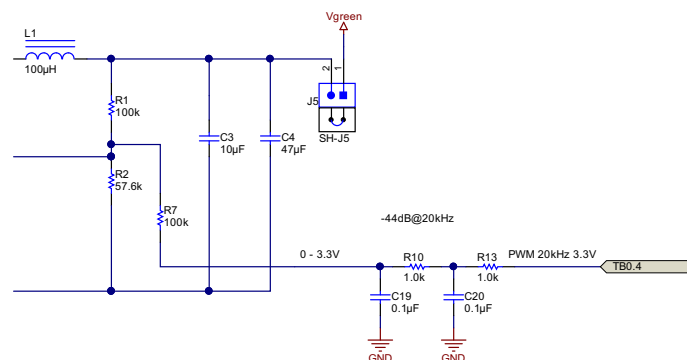

Copyright © 2017, Texas Instruments Incorporated

図 14. Schematic of Voltage Control for Voltage Regulator

☒ 14 shows how this control is implemented. The PWM signal from the MSP430FR5969 is low-pass filtered using a two-stage RC filter, resulting in an analog voltage depending on the duty cycle of the PWM signal. This analog voltage is injected in the feedback network of the voltage regulator, resulting in the possibility to control the output voltage.

For this reference design, this circuit is built three times to control the voltage of each color. The calculation of the feedback network is shown in 式 4 to 式 7.

$$R_{12} = R_1 \times R_2 \quad R_1 + R_2 = 100 \text{ k}\Omega * 57.6 \text{ k}\Omega / 100 \text{ k}\Omega + 57.6 \text{ k}\Omega = 36.55 \text{ k}\Omega \quad (4)$$

$$R_{27} = R_2 \times R_7 \quad R_2 + R_7 = 100 \text{ k}\Omega * 57.6 \text{ k}\Omega / 100 \text{ k}\Omega + 57.6 \text{ k}\Omega = 36.55 \text{ k}\Omega \quad (5)$$

$$V_{min} = (U_{fb} - R_{12} \times V_{PWM} / (R_{12} + R_7)) * (R_{12} + R_1) / R_{72} = (1.223 \text{ V} - 36.55 \text{ k}\Omega * 3.3 \text{ V} / 36.55 \text{ k}\Omega + 100 \text{ k}\Omega) * (36.55 \text{ k}\Omega + 100 \text{ k}\Omega) / 36.55 \text{ k}\Omega = 1.3 \text{ V} \quad (6)$$

$$V_{max} = U_{fb} \times (R_{12} + R_1) / R_{27} = 1.223 \text{ V} * (36.55 \text{ k}\Omega + 100 \text{ k}\Omega) / 36.55 \text{ k}\Omega = 4.6 \text{ V} \quad (7)$$

More accurate values can be achieved by simulation because the RC filter as well as the output resistance of the MSP430 is neglected in this calculation.

The type-3 ripple generation method uses the voltage on the switch node to inject a ripple voltage to the feedback node. Because it does not use the output voltage to generate ripple, it is suited for applications where a low ripple is desired. 式 8 to 式 12 show how the margins of the ripple injection network can be calculated.

$$C_1 = C_A \geq 5 / (F_{sw} \times (R_1 || R_2)) = 5 / (200 \text{ kHz} * 36.55 \text{ k}\Omega) = 0.68 \text{ nF} \quad (8)$$

$$C_2 = C_B \geq 1 / (2 \pi \times F_{sw} \times (R_1 || R_2)) = 1 / (2 \pi * 200 \text{ kHz} * 36.66 \text{ k}\Omega) = 22 \text{ pF} \quad (9)$$

$$T_{on} = V_{out} / (V_{in} \times F_{sw}) = 5.5 \text{ V} / (36 \text{ V} * 200 \text{ kHz}) = 0.76 \mu\text{s} \quad (10)$$

$$R_3 \times C_1 = R_A \times C_A \leq (V_{in} - V_{out}) * T_{on} / 20 \text{ mV} = (36 \text{ V} - 5.5 \text{ V}) * 0.76 \mu\text{s} / 20 \text{ mV} = 1.159 * 10^{-3} \quad (11)$$

$$R_3 = R_A \leq 1.159 * 10^{-3} / C_A = 1.159 * 10^{-3} / 0.68 \text{ nF} = 1.7 \text{ M}\Omega \quad (12)$$

For further information on how to design the ripple generation network, see the application report [Selecting an Ideal Ripple Generation Network for Your COT Buck Converter](#).

The next step is to calculate an inductor value; to do so, the inductor ripple current must be defined. Typically, this current is chosen to be between 30% and 60%. In this case, it is selected to be 40% of the maximum output current, resulting in 200 mA. The calculation is shown in 式 13. The selected inductor value is 100 μ H.

$$L_1 = L_F = V_{out} / (F_{sw} \times \Delta I_L \times (1 - V_{out} / V_{in})) = 5.5 \text{ V} / (200 \text{ kHz} * (40\% * 500 \text{ mA}) * (1 - 5.5 \text{ V} / 24 \text{ V})) = 106 \mu\text{H} \quad (13)$$

The minimum output capacitance depends on the desired output voltage ripple. In this case, a ripple of 10 mV is defined for calculations. 式 14 shows the way the capacitance is calculated.

$$C_{out} \geq \Delta I_L / (8 \times F_{sw} \times \Delta V_{out}) = 200 \text{ mA} / (8 * 200 \text{ kHz} * 10 \text{ mV}) = 12.5 \mu\text{F} \quad (14)$$

This reference design uses capacitors at 10 μ F and 47 μ F in parallel. Look at the voltage derating of the capacitor to know the capacitance at the applied voltage. As a result, a voltage rating of 25 V for the 10- μ F capacitor is chosen. It is placed as close as possible to the LM5166 and the input capacitor. The 47- μ F capacitor is not that critical and is chosen to be a 10-V type. All capacitors have X7R dielectricum.

As an input capacitor, a 2.2- μ F X7R with a voltage rating of 100 V is selected and placed close to the device to keep the high current loop small. 図 15 shows the placement of these parts. C5 as the input capacitor must be close to the input pin and GND. The output capacitor C4 is close to the GND node of the input loop as well as the inductor, so the high current path is small. The feedback network is located close to the device to keep the length of the high-impedance line short.



図 15. Layout of LM5166

For more information and a helpful design tool, see the [LM5166 product folder](#).

When a solution with a small footprint is desired and low output ripple is not the main design criteria, choosing the PFM mode is a good way. This design can easily be modified to evaluate the performance of PFM mode. By changing R8 to 0 Ω, the device operates in PFM mode. The inductor must be changed to have a value above 8.5 μH, as calculated in 式 15.

$$L_1 = V_{Out} F_{Sw} \times I_{Pk} \times (1 - V_{Out} / V_{In}) = 5.5 \text{ 400 kHz} \times 1.25 \text{ A} \times (1 - 5.5 \text{ V} / 24 \text{ V}) = 8.5 \text{ } \mu\text{H} \quad (15)$$

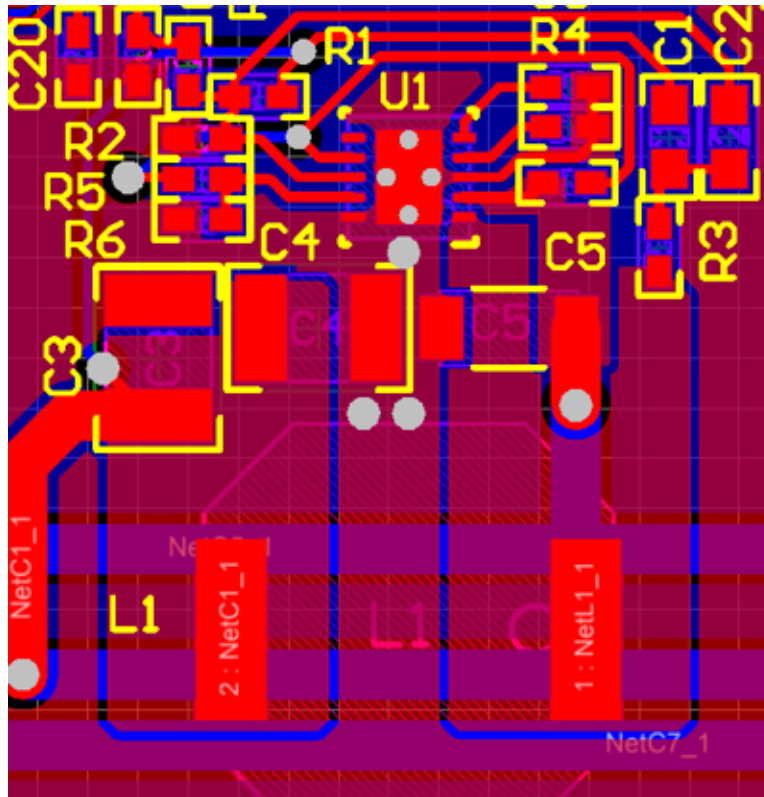
The minimal output capacitor can be determined by 式 16.

$$C_{Out} \geq 50 \times L_1 \times (I_{Pk} / V_{Out})^2 = 50 \times 8.5 \text{ } \mu\text{H} \times (1.25 \text{ A} / 5.5 \text{ V})^2 = 22 \text{ } \mu\text{F} \quad (16)$$

For testing the PFM mode, the output capacitor remain unchanged, the ripple generation network is removed and the inductor is reduced to 22 μH with enough current capability.

2.3.2 TPS54062 3.3-V Regulator Design

Even though the TIOL111 is available with an integrated 3.3-V LDO, it is necessary to have an external voltage regulator because the TIOL111 cannot handle the current necessary on the 3.3-V rail. The TLC5971 has a specified current consumption of maximum of 9 mA at a 30-mA output current and no clocking. Therefore, the 3.3 V must supply at least 45 mA for the TLC5971 and a few more milliamps for the MSP430 MCU, the TIOL111, and the sensors.

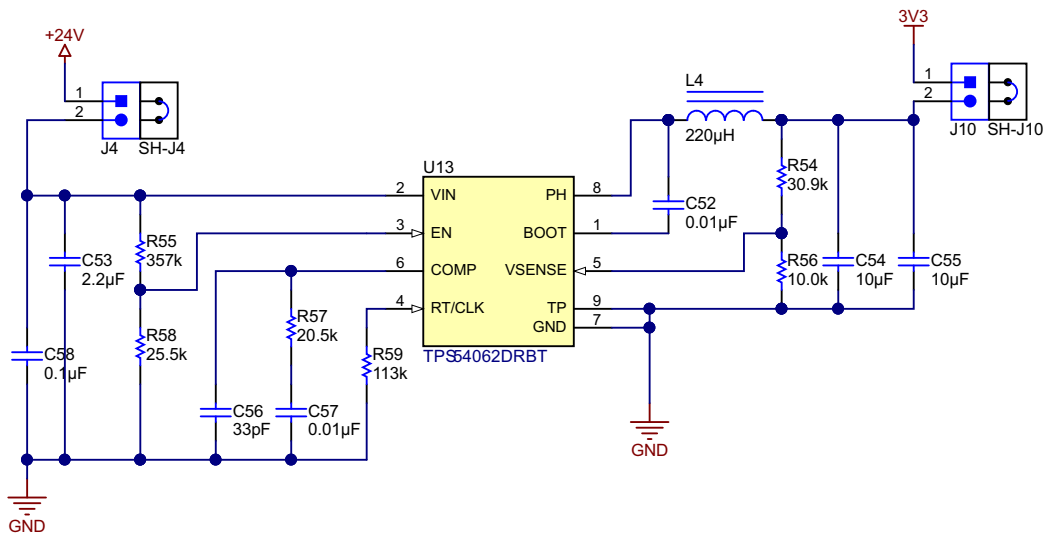

Copyright © 2017, Texas Instruments Incorporated

図 16. 3.3-V Regulation From 24 V

The parts of the TPS54062 regulator are calculated by using the calculator tool in the [TPS54062 product folder](#).

To keep the output ripple on the 3.3 V low, an inductor value larger than the calculated value (220 µH instead of 150 µH) and a larger output capacitor are used.

2.3.3 LED Driver

There are many solutions for controlling LEDs. The LED requires a constant current. The variety of available LEDs is large, and the brightness is usually dependent on the current that is going through the LED.

In this reference design, the 12-channel RGB LED driver (TLC5971) controls the LEDs and provides the following advantages:

- Dedicated RGB LED controller
- Twelve independent constant-current sinks to adjust to the current for each channel
- Ability to use the driver with different types of LEDs with up to 60 mA for each channel
- Simple two-wire interface to control the TLC5971 from an MCU
- Several devices can be daisy-chained

図 17 shows the schematic of one LED driver. Typically, the LED driver is powered through the VCC pin with a voltage of minimum 6 V and delivers a regulated 3.3 V at the VREG output. When the device must operate below 6 V and the internal regulator is not used, VCC and VREG must be tied together to the desired voltage.

The maximum output current of the LED driver is set by a resistor at the IREF pin to GND. Additionally, an internal 7-bit wide register is used for a global brightness control, allowing a reduction of the current down to 1/127th of the programmed maximum current. When high-brightness LEDs are used or a high LED current is set, even the lowest current might be too bright in some circumstances. In this case, the current can be programmed to a low value, and a second resistor switched with a MOSFET can be connected in parallel when high current is necessary.

In an separate mode, the residue voltage is measured and the LED voltage is regulated to the minimal possible value for the given current. This process is done for multiple currents and stored. During runtime, these values are used. Whenever the LED with voltage monitoring is turned on, the PWM value for the corresponding channel is reduced or increased, depending on the measured voltage drop.

2.3.4 IO-Link Interface

The IO-Link interface is implemented using the TIOL111. The TIOL111 itself is protected from reverse voltage, overvoltage, and transients. When using the internal voltage regulator to supply the whole circuit, it is not necessary to add external protection.

As this reference design uses external voltage regulators, they must be protected. For protection, two TVS3300 are used as a bidirectional overvoltage protection diode. In addition, a diode is used as a reverse protection diode.

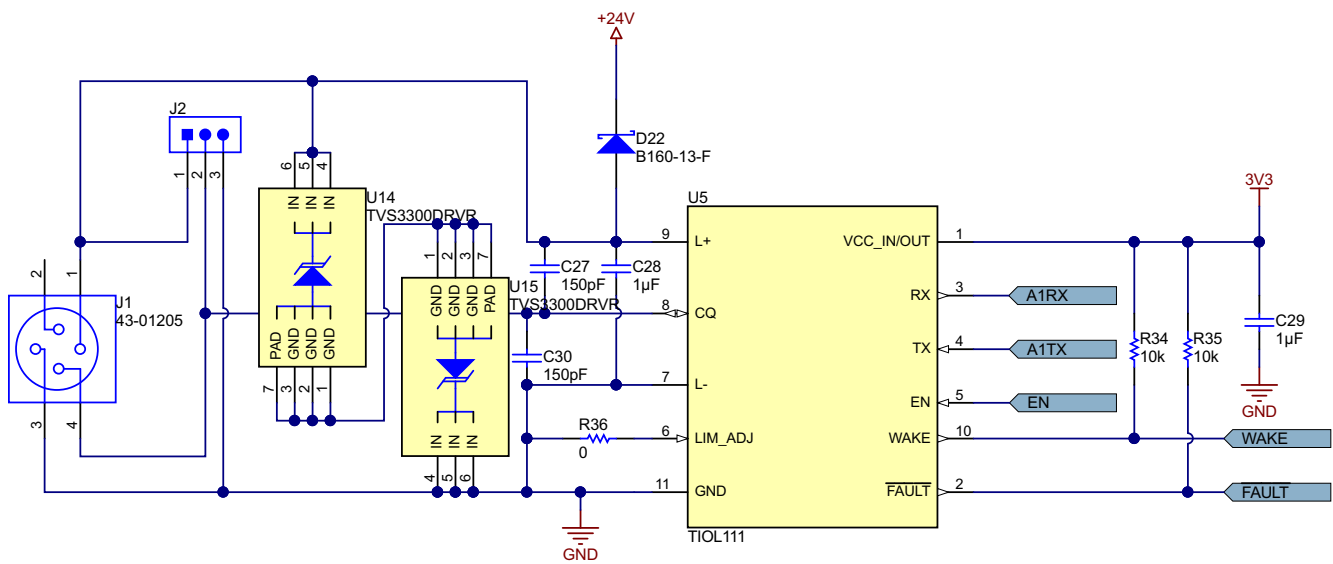

Copyright © 2017, Texas Instruments Incorporated

図 18. Schematic of IO-Link Interface With TIOL111

The TIOL111 is powered by 3.3 V and connected to the MSP430. The RX and TX signals are connected to UCA1 of the MSP430FR5969. The remaining signals are connected to GPIOs for enabling the TIOL111 and getting feedback.

2.3.5 Sensors

To implement brightness control, an OPT3001 brightness sensor with I²C interface is added.

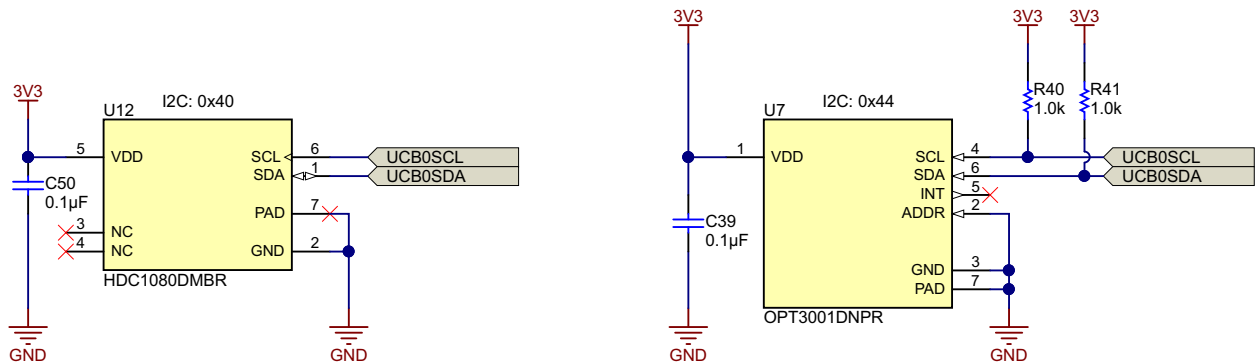

Copyright © 2017, Texas Instruments Incorporated

19. Schematic of Sensors on Stacklight Reference Design

Additionally, an HDC1080 temperature and humidity sensor is present. Both sensors are connected to UCB0 operating in I²C mode.

2.3.6 Firmware Implementation

This reference design includes a firmware implementing an IO-Link stack, the control of the LED drivers, and the controller for the adjustable buck regulator.

2.3.6.1 IO-Link Communication

The IO-Link stack is developed by TE Concept. It is not part of this design and not explained in detail.

2.3.6.1.1 IO-Link Parameters

The device uses a COM2 bitrate and a cycle time of 19,200 μs. Process data is not used; all relevant communication is exchanged using ISDU parameters. 表 3 gives an overview of the parameters that can be read and set through IO-Link.

表 3. Parameters of IO-Link Communication

PARAMETER INDEX (DECIMAL)	VARIABLE	COMMENT	ACCESS / LENGTH (BYTE)
64	stacklight_mode	Operation mode:	rw / 1
		0: Demo mode	
		1: Temperature visualization	
		2: Humidity visualization	
		3: Stacklight mode	
		4: Calibration mode	
5: Stacklight full power mode			
65	stacklight_temp	Temperature measured by HDC1080	ro / 2
66	stacklight_hum	Humidity measured by HDC1080	ro / 2
67	adc_r	Raw value of ADC channel connected to red LED	ro / 2
68	adc_g	Raw value of ADC channel connected to green LED	ro / 2
69	adc_b	Raw value of ADC channel connected to blue LED	ro / 2
70	stacklight_pattern	Selected pattern to be displayed in stacklight mode	rw / 1
71	stacklight_color	LED color in stacklight mode	rw / 3
72	stacklight_brightness	LED brightness in stacklight mode	rw / 1

表 3. Parameters of IO-Link Communication (continued)

PARAMETER INDEX (DECIMAL)	VARIABLE	COMMENT	ACCESS / LENGTH (BYTE)
73	temp_min	Temperature minimum value used for scaling in temperature mode	rw / 2
74	temp_max	Temperature maximum value used for scaling in temperature mode	rw / 2
75	level_min	value used for scaling in level mode	rw / 2
76	level_max	value used for scaling in level mode	rw / 2
77	data	process data for selected pattern in stacklight mode	rw / 4
78	pwm_r	PWM value for red LED voltage	rw / 1
79	pwm_g	PWM value for green LED voltage	rw / 1
80	pwm_b	PWM value for blue LED voltage	rw / 1
81	stacklight_lx	Brightness measured by OPT3001	ro / 4

The usage of the data parameter (77) depends on the selected pattern (parameter 70). These values are only used when mode (64) is set to 3 or 5. 表 4 explains the usage of the data parameter in that case.

表 4. Data Parameter

PATTERN VALUE	PATTERN	DATA PARAMETER
0	On	Number of LEDs to turn on
1	Off	Number of LEDs to turn off
2	Blinking	Bits 31 to 24: on time Bits 23 to 16: off time Bits 7 to 0: number of rows to blink
3	Temperature	Temperature value to be displayed
4	Stacklight	Bits 19 to 17: Segment 5 color Bit 16: Segment 5 blink Bits 15 to 13: Segment 4 color Bit 12: Segment 4 blink Bits 11 to 9: Segment 3 color Bit 8: Segment 3 blink Bits 7 to 5: Segment 2 color Bit 4: Segment 2 blink Bits 3 to 1: Segment 1 color Bit 0: Segment 1 blink
5	Run light	Bits 31 to 16: speed Bit 7 to 0: row
6	Level	Level value to be displayed

Some example parameters are explained in 3.1.2.

The parameters 65 (temperature), 66 (humidity), and 81 (brightness) are read only and represent the converted sensor values. These values are also used internally for the different implemented examples.

For demonstration and debug purposes, the converted voltage drop over the TLC5971 can be read from parameter 67 to 69. Depending on the selected current, the reading must be around 512 for the lowest brightness, 716 for the next step, and 1024 for the highest current. When these parameters are read during the LED with ADC connection off, -1 is read back. Because these are the unfiltered values from the ADC, it is normal that they change slightly. When full power mode of the stacklight is selected, the control of the LED voltage is turned off and the read back ADC values will be up to 4095, which is the maximum reading of the ADC. It is possible to get a lower reading depending on the ambient conditions and variation of the LEDs. In this case, the voltage drop over the TLC5971 can be over 2 V for some channels.

The PWM values of the different channels can be read as IO-Link parameters from 78 to 80. In full power mode, the PWM value is set to 0, which results in the highest possible output voltage. In normal operation, the value is somewhere between 0 to 100—the higher the current, the lower the PWM value.

2.3.6.2 LED Control

The software implements different pattern, which can be controlled using IO-Link interface. The TLC5971 LED driver are connected in series and behave like a shift register. It is possible to control each LED individually, so the user can program to display any pattern. For demonstration, the following patterns are implemented:

- LEDs on: Turn a given number of LEDs on in a given color and brightness
- LEDs off: Turn off all LEDs
- Blinking: Blink with a given number of LEDs and given on or off time
- Temperature pattern: Display a temperature gradient
- Stacklight: Separate the light into five segments. Each segment can be controlled in color and state (on/off/blinking)

- Run light: Display a running light
- Level light: Display a bar with a given number of LEDs

The additional MOSFET to change the current (as explained in 2.3.3) set resistor is handled in software with the highest bit of the 8-bit wide brightness value. Setting this bit increases the maximum current to 20 mA instead of 2 mA.

2.3.6.3 Voltage Control

To keep the power dissipation in the TLC5971 low, the voltage of the LM5166 is tracked depending on the selected current. The output voltage is adjusted through PWM as explained in 2.3.1. The output current of the LED driver is not measured, but set by the software. Depending on the current set value, the residue voltage is defined in two steps from below 10 mA (350 mV) and 500 mV above 10 mA. In the low current mode (2 mA maximum), a third step of 250 mV is used.

In a special mode, the necessary PWM values are determined by turning on the LEDs with voltage measurement to the desired current and the PWM value is increased until the desired residue voltage is reached.



図 20. PWM Adjustment

図 20 shows the voltage drop over one channel of the TLC5971 and how the calibration process works. The PWM value is set to an initial starting point (stored in a look-up table), and from this value, the PWM value is either increased or decreased, depending on the error from the desired voltage.

The D1 channel marks when a suitable value for the given current is found and stored. The whole process is repeated for three current steps.

During run time, it is possible to use either only the values obtained during calibration process or dynamically measure the voltage whenever an LED with voltage measurement is turned on and modify the PWM value depending on this voltage. For demonstration, it is possible to disable dynamic headroom control and set the LM5166 to maximum output voltage through IO-Link.

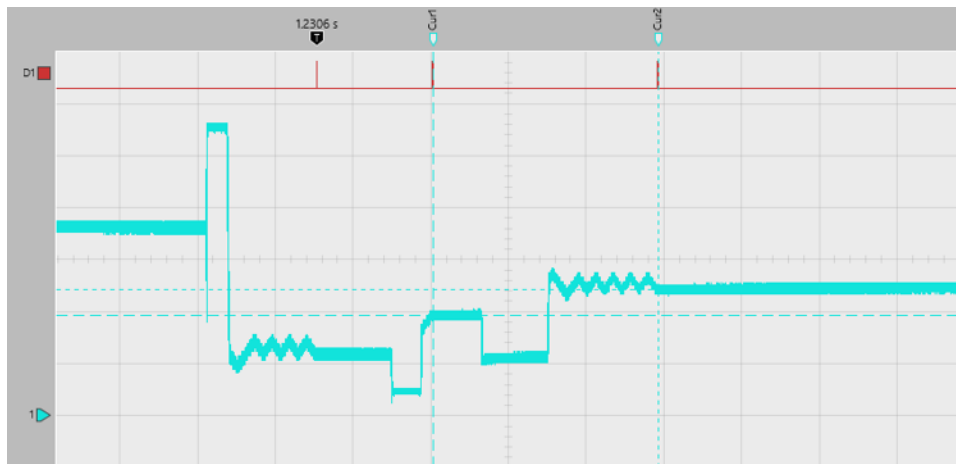
To optimize this further, one can define more current points and use a finer graduation for setting the residue voltage.

2.3.6.4 **Brightness Control**

To adapt the brightness depending on the ambient brightness, as it is done in smartphones and other handheld devices, a OPT3001 is added. So the stacklight reference design is programmed to change the brightness to have a good visibility but not to be too bright in a dark environment.

Therefore, the reading of the ambient brightness is polled regularly from the OPT3001 and used for calculating the brightness value in the demo mode. The range is limited to stay within the 20-mA range with a minimal current of 0.16 mA.

For demonstration and evaluation purposes, it is not implemented in other modes where the user can set the brightness using IO-Link.

3 Hardware, Software, Testing Requirements, and Test Results

3.1 Required Hardware and Software

This section gives an quick introduction on how this reference design is brought up and what can be configured.

3.1.1 Hardware

First, make sure the jumper settings are correct.  21 shows position of the relevant jumper and test points.

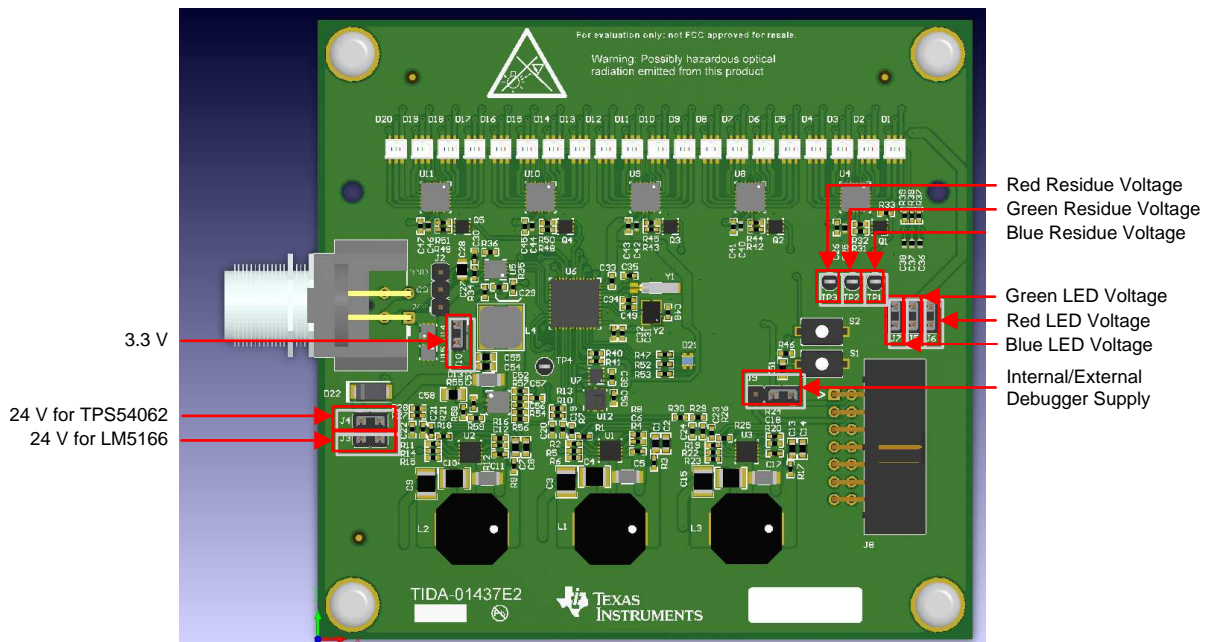

Copyright © 2017, Texas Instruments Incorporated

 21. Jumper and Test Points

表 5 shows the default settings and gives a short explanation of the use of the jumpers.

表 5. Default Jumper Configuration

JUMPER	DEFAULT POSITION	DESCRIPTION
J3	1-2	24 V for LM5166 LED supply
J4	1-2	24 V for TLC5971, MSP430, Sensors, and IO-Link PHY
J5	1-2	LED voltage for green LEDs
J6	1-2	LED voltage for red LEDs
J7	1-2	LED voltage for blue LEDs
J9	1-2	Internal and external Supply for MSP430 debugger
J10	1-2	3.3 V from TPS54062

Except for J9, all jumpers are used for current measurement of different parts of the design, so they must be shorted during normal operation. For further details about the jumper connections, see 4.1.

When IO-Link communication is not necessary, 24 V can be connected to J2 (24 V: Pin 1, 0 V: Pin 3) from a power supply delivering a minimum of 500 mA. The design powers on and first determine the proper PWM values for three LED currents. During this process, LED1 is turned on in white and changes the brightness.

Afterwards it will enter demo mode, the different implemented pattern will loop through. During this, brightness control is active. When the OPT3001 (U7) is covered, the LED brightness fades down; when it is exposed to light, the LED brightness increases.

Dynamic headroom control is also active. The voltage drop over the TLC5971 is regulated depending on the brightness of the LEDs. So the output voltage of the three LM5166 will be different, whereas the voltage on TP1 to TP3 will be the same.

To test the IO-Link communication, connect an IO-Link master to the connector J1. The master must be capable to deliver 24 V at 500 mA.

3.1.2 Software

To get started controlling the reference design using software, a PC running Windows® and an IO-Link master is required. In this example, a TMG-USB IO-Link Master V2 with the corresponding IO-Link tool is used. Connect the IO-Link master to J1 of the system.

After connecting the reference design to a powered IO-Link master, it turns on in demo mode. The IO-Link communication is initialized and can be used for connecting and controlling the system. 表 3 lists the implemented parameters.

Start the IO-Link Device Tool and click "Select Master" (see 図 22).



図 22. IO-Link Device Tool Start

A second window shows up and lists the connected devices. Select the master by double clicking on it (see [Figure 23](#)).

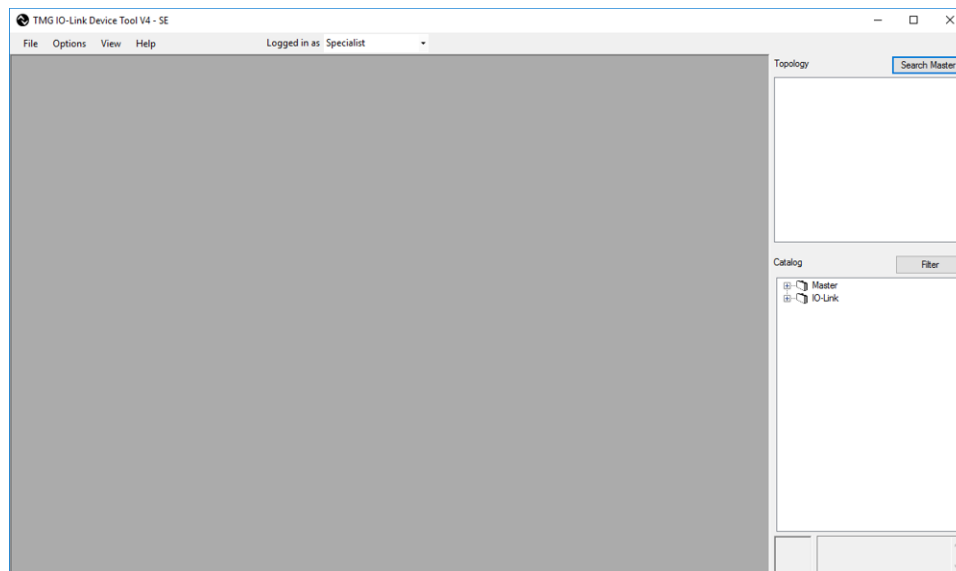
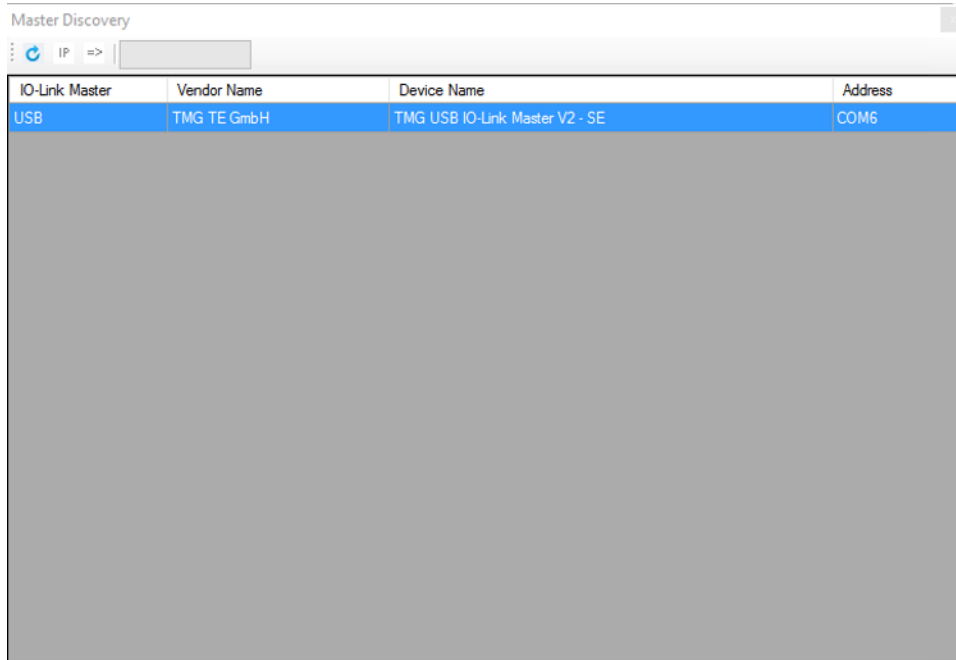

Figure 23. IO-Link Device Tool Search Master

The window then closes and it goes back to the main window (see [Figure 24](#)).

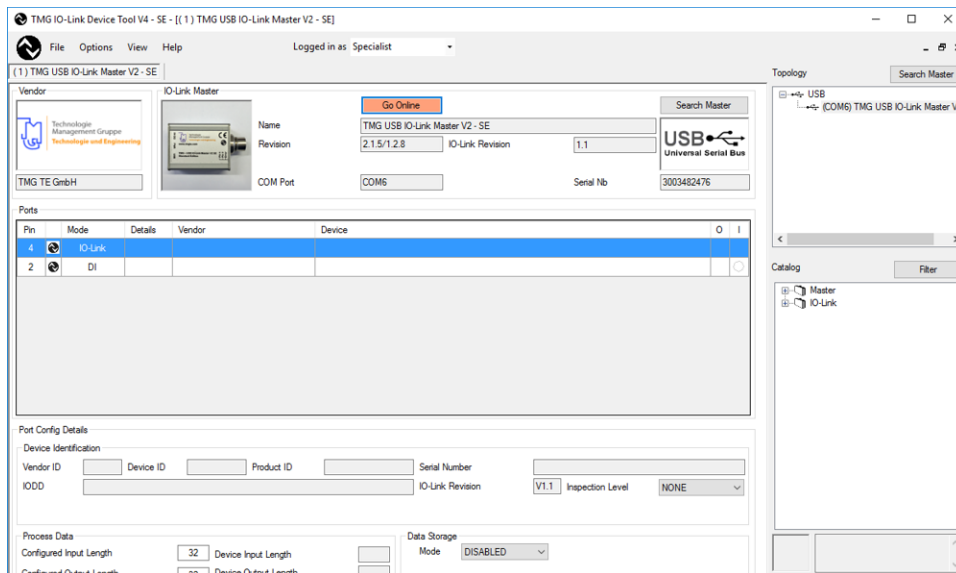

Figure 24. IO-Link Device Tool Master Selected

In the next step, click on "Options" in the toolbar and select "Import IODD". Navigate to the location of the IODD file and import (see [Figure 25](#)).

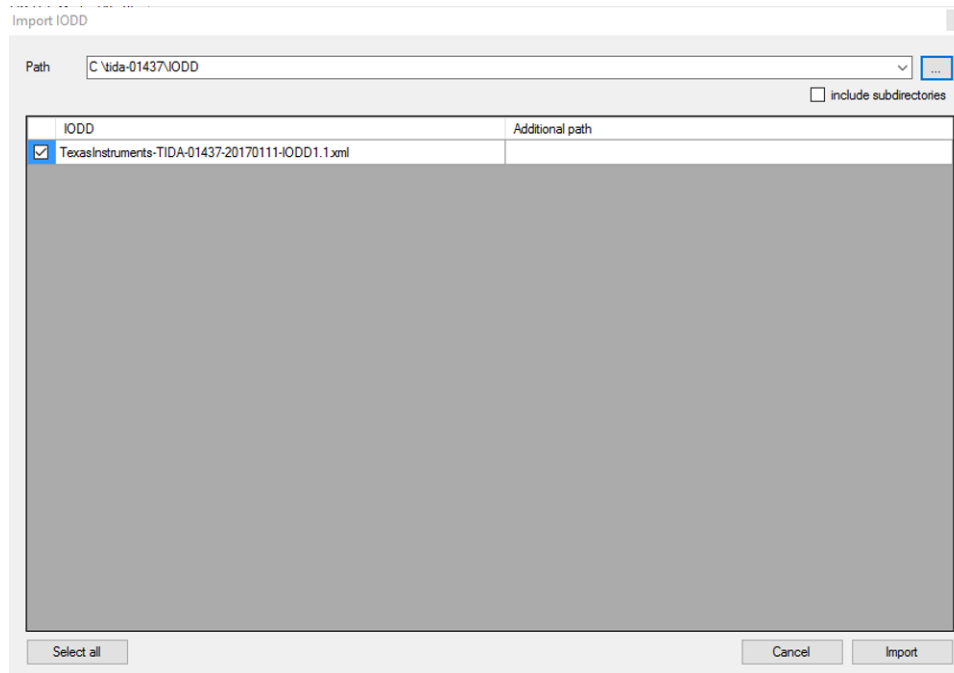

Figure 25. IO-Link Device Tool Import IODD

Back on the main screen, click on "Go online" and then click on "Check Devices" (see [Figure 26](#)).

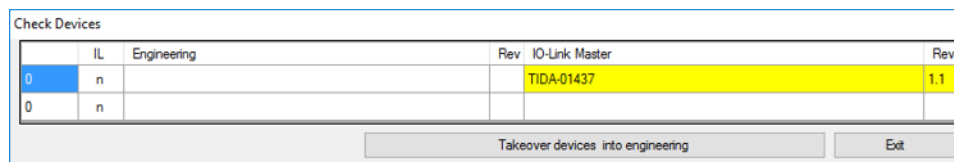

Figure 26. IO-Link Device Tool Check Devices

When the IO-Link master finds the reference design, select the design and click on "Takeover devices into engineering". The main screen now appears and the stacklight reference design is selected (see [Figure 27](#)).

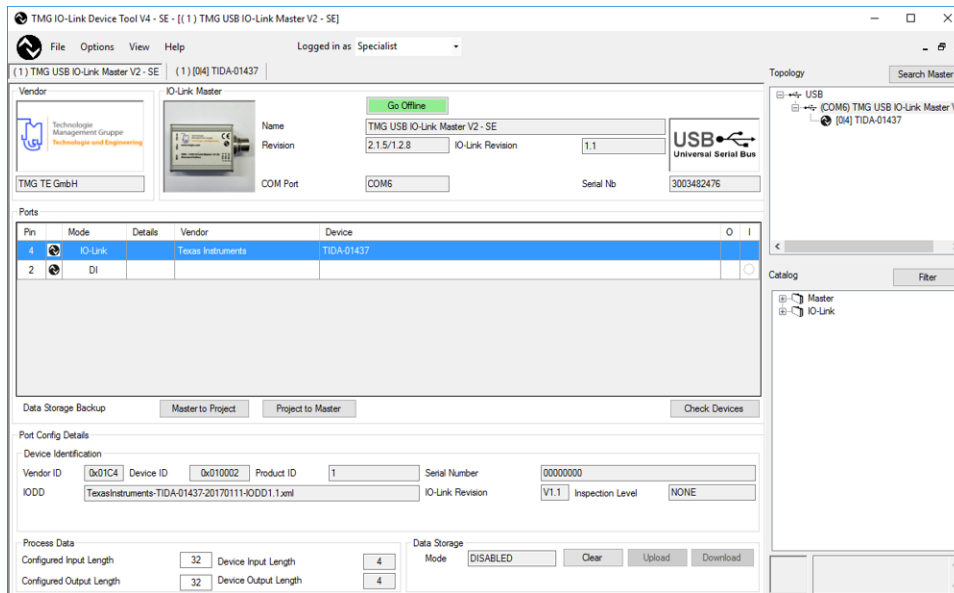

Figure 27. IO-Link Device Tool Main Screen With Reference Design

By double clicking on the reference design, it switches over to the configuration window of design, showing the common tab with some information about the device (see [Figure 28](#)).

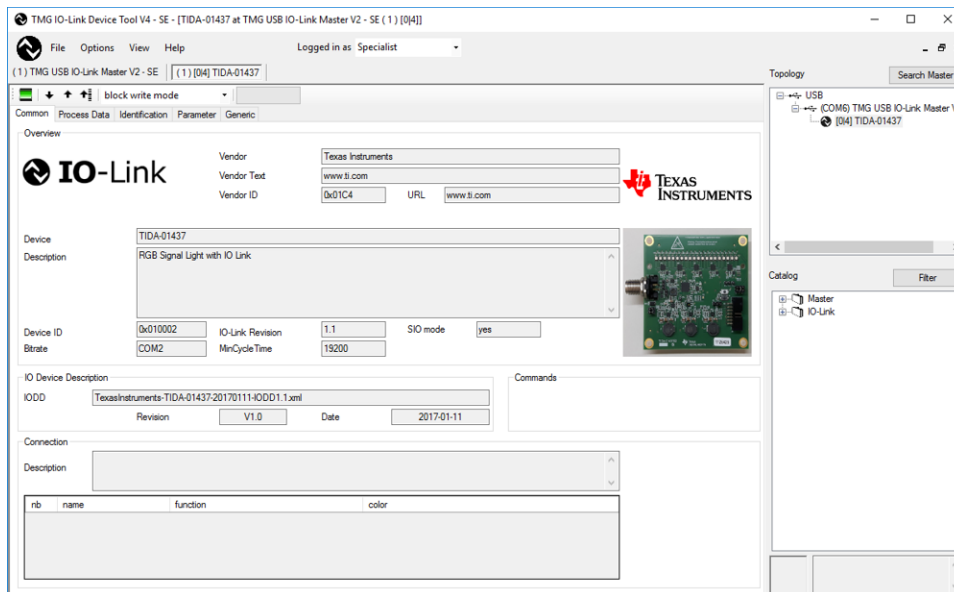

Figure 28. IO-Link Device Tool Common

The parameter tab shows where every parameter mentioned in [Table 3](#) is accessible. In this example, the reference design is switched to stacklight mode with one LED on. In this case, the ADC values are between 659 and 697, equaling a voltage of 322 to 340 mV. These values change with every reading. A value of -1 is read when the corresponding LED is off.

The PWM value also changes when setting the output voltage (see [Figure 29](#)).

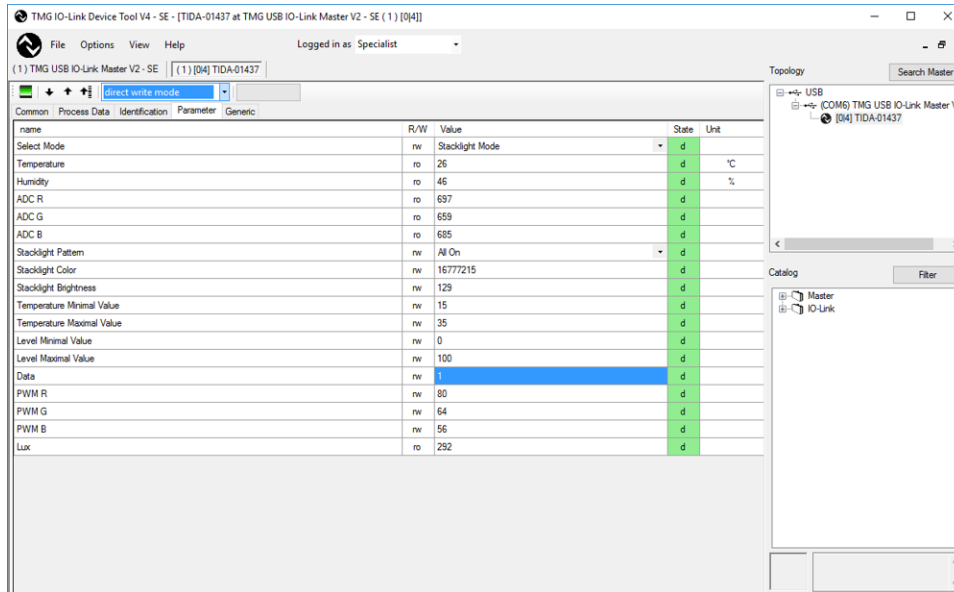

Figure 29. IO-Link Device Tool Parameter

Another way to read and write parameters is using the Generic tab. Here, the index of the parameters in [Table 3](#) must be entered. When reading or writing data with more than one byte length, the data must be split in 8-bit wide segments. The shown example reading index 67 with a data of 1,221 equals $1 \times 256 + 221 = 477$ (see [Figure 30](#)).

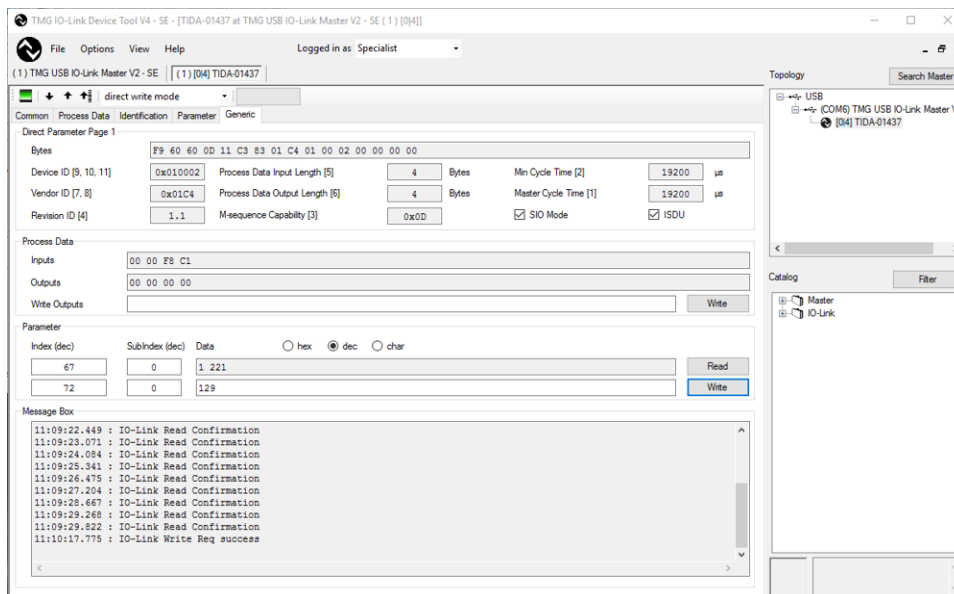

Figure 30. IO-Link Device Tool Generic Settings

3.1.3 Configuration Examples

Some configurations are especially interesting for demonstrating the headroom control. To enable control, select the "stacklight mode" and turn on at least 1 LED by setting "Data" to 1. The brightness is set to 129, which results in an LED current of:

$$I_{LED} = 20 \text{ mA} \cdot 129 \cdot 1 = 0.16 \text{ mA} \quad (17)$$

Because the brightness value is above 128, the high current mode is selected, and the minimal residue voltage is 350 mV.

Select Mode	nw	Stacklight Mode	d
Temperature	ro	26	d
Humidity	ro	42	d
ADC R	ro	633	d
ADC G	ro	719	d
ADC B	ro	687	d
Stacklight Pattern	nw	All On	d
Stacklight Color	nw	16777215	d
Stacklight Brightness	nw	129	d
Temperature Minimal Value	nw	15	d
Temperature Maximal Value	nw	35	d
Level Minimal Value	nw	0	d
Level Maximal Value	nw	100	d
Data	nw	1	d
PWM R	nw	81	d
PWM G	nw	63	d
PWM B	nw	56	d
Lux	ro	290	d

図 31. Brightness Setting With Headroom Control

The ADC values representing the residue voltage show something equaling about 350 mV. This value changes several digits with every reading. The PWM values also change one or two digits.

Now change the brightness to maximum by entering "255" in the brightness field (see [図 32](#)).

name	R/W	Value	State
Select Mode	rw	Stacklight Mode	d
Temperature	ro	27	d
Humidity	ro	39	d
ADC R	ro	996	d
ADC G	ro	1033	d
ADC B	ro	1022	d
Stacklight Pattern	rw	All On	d
Stacklight Color	rw	16777215	d
Stacklight Brightness	rw	255	d
Temperature Minimal Value	rw	15	d
Temperature Maximal Value	rw	35	d
Level Minimal Value	rw	0	d
Level Maximal Value	rw	100	d
Data	rw	1	d
PWM R	rw	63	d
PWM G	rw	40	d
PWM B	rw	39	d
Lux	ro	295	d

図 32. Maximum Brightness With Headroom Control

After reading back all values, the ADC values are around 1024, which equals 500 mV of residue voltage. The PWM values are lower than before as the output voltage is increased. A lower PWM value causes a higher voltage.

When the mode is switched to "Stacklight Full Power Mode", the headroom control is turned off and the output voltage is set to 4.6 V for each channel (see 図 33).

name	R/W	Value	State
Select Mode	rw	Stacklight Full Power Mode	d
Temperature	ro	26	d
Humidity	ro	42	d
ADC R	ro	4095	d
ADC G	ro	3643	d
ADC B	ro	3582	d
Stacklight Pattern	rw	All On	d
Stacklight Color	rw	16777215	d
Stacklight Brightness	rw	255	d
Temperature Minimal Value	rw	15	d
Temperature Maximal Value	rw	35	d
Level Minimal Value	rw	0	d
Level Maximal Value	rw	100	d
Data	rw	1	d
PWM R	rw	0	d
PWM G	rw	0	d
PWM B	rw	0	d
Lux	ro	0	d

図 33. Maximum Power Without Headroom Control

Now the residue voltage is much higher than before and might even clip at 4095 digits as it is above 2 V. The PWM value is forced to 0.

3.2 Testing and Results

For obtaining the measurements, a power supply is connected to the IO-Link connector. The input voltage and current is measured on J3. The output voltage and LED currents are measured on J5 to J7. The voltage drop on the TLC5971 on TP1 to TP3.

3.2.1 LED Voltage versus Current

The forward voltage of one LED is measured at different currents. [Figure 34](#) shows the results. The LED forward voltage for red and green is exactly as specified in the datasheet, whereas the forward voltage for the blue LED is about 200 mV below the typical value.

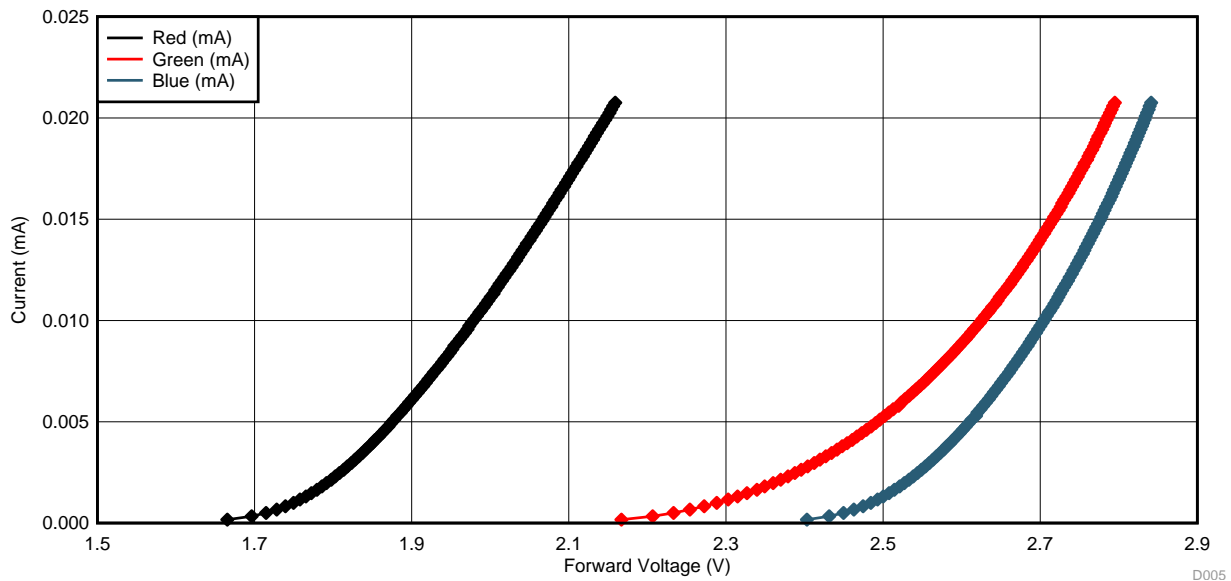

Figure 34. LED Forward Voltage

3.2.2 Impact of Dynamic Headroom Control

To show the impact of dynamically controlling the voltage to reduce power consumption and heat dissipation, the number of active LEDs and the power consumption are analyzed. All measurements are done using the LM5166 in COT mode with a 24-V input voltage. In all cases, the power for the MSP430 and the LED driver is included in the results.

[Figure 35](#) shows the power consumption for 20mA per LED. In each step, one more RGB LED is turned on, so the current on each LM5166 is increased by 20 mA. When headroom control is enabled, the output voltage of the LM5166 is 2.6 V for the red channel, 3.3 V for green, and 3.4 V for the blue channel. Disabling headroom control increases the voltage to 4.6 V for each channel.

[Figure 36](#) repeats this measurement with an LED current of 2 mA/LED. When headroom control is enabled, the output voltage of the LM5166 is 2 V for the red channel, 2.7 V for green, and 2.8 V for the blue channel. Disabling headroom control increases the voltage to 4.6 V for each channel.



図 35. Input Power at 24 V and 20 mA/LED



図 36. Input Power at 24 V and 2 mA/LED

As shown in 図 35 and 図 36, using different voltages for the three different colored LEDs has a huge impact in the power consumption. In this case, the maximum power consumption is decreased from 6.5 W to 4.5 W.

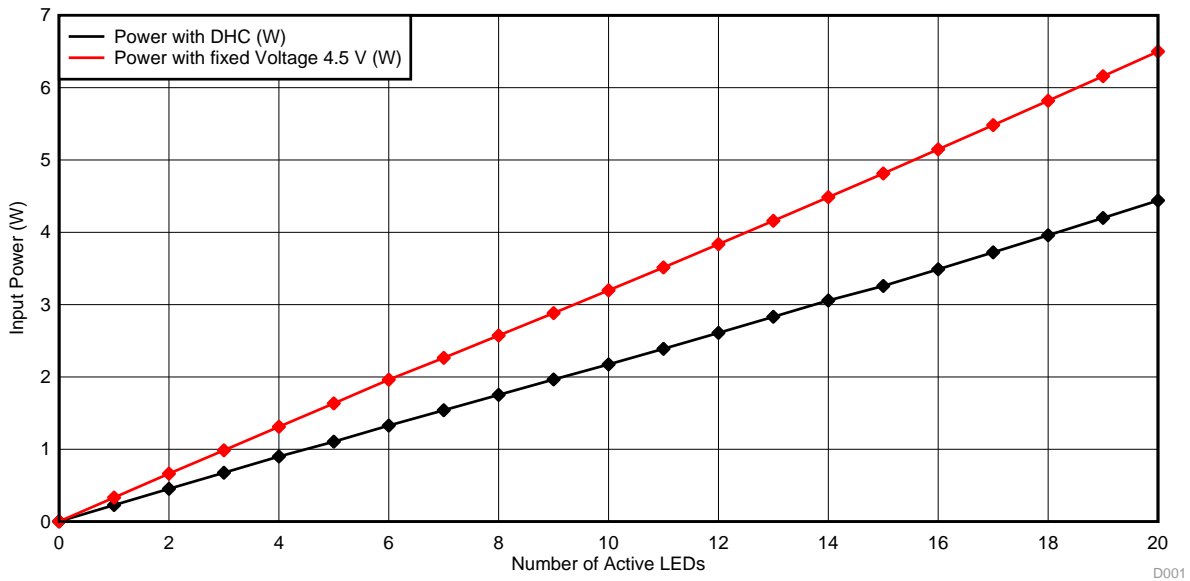
3.2.3 Voltage Drop on TLC5971

3.2.3 shows how the voltage drop over the TLC5971 LED driver is measured without headroom control. The voltage drop here only depends on the forward voltage of the LED and the output voltage of the LM5166. When headroom control is enabled, the voltage is regulated to a constant value.

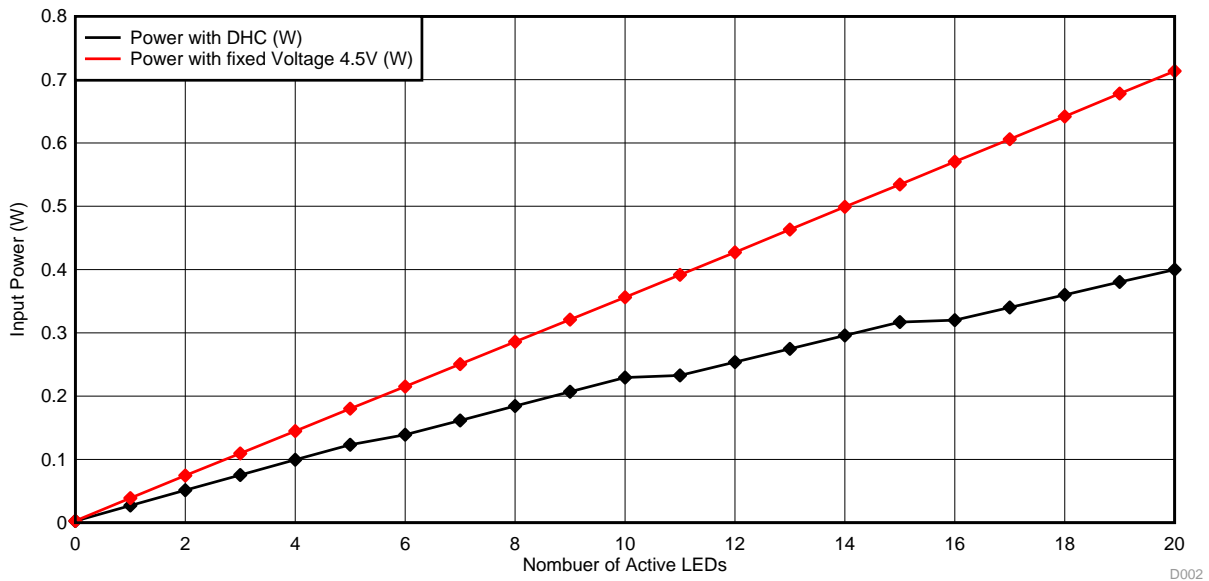

図 37. Voltage Drop on TLC5971 With No Headroom Control

When headroom control is enabled, the voltage drop over the TLC5971 is reduced. 38 shows the drop. The software is programmed to regulate to 350 mV up to a 10-mA LED current and to 500 mV for more than 10 mA. The software regulator is always trying to improve the error between the measured and the programmed voltage, so a ripple of a few millivolts can be seen.

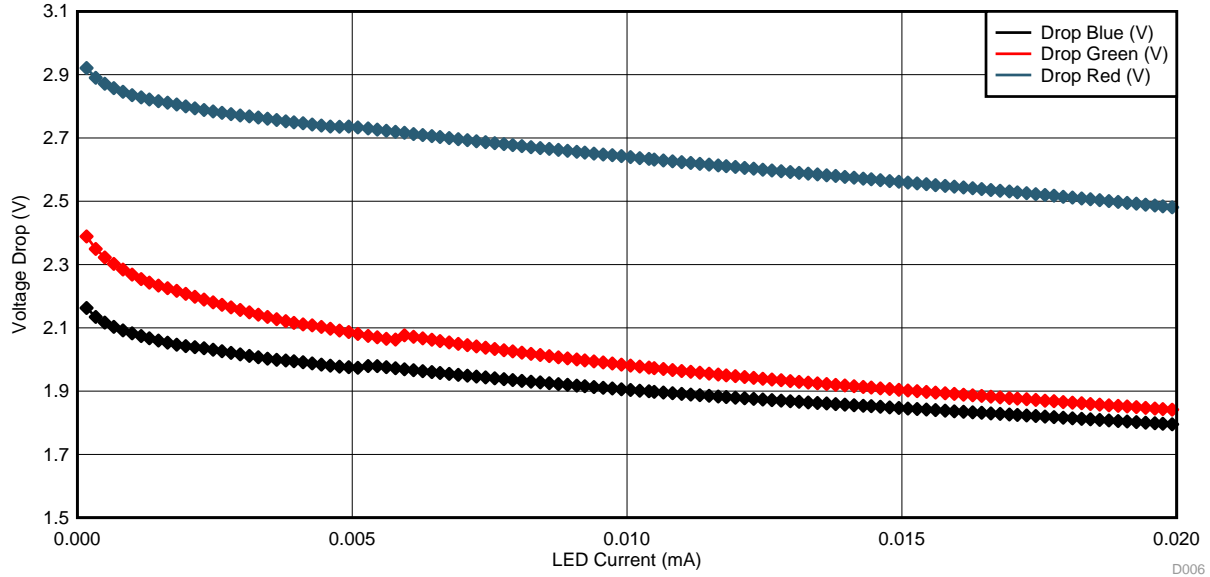

図 38. Voltage Drop on TLC5971 With Headroom Control

3.2.4 Brightness Control of TLC5971

Figure 39 shows the resulting output current depending on the brightness control register of the TLC5971 when it is configured to deliver 20 mA.

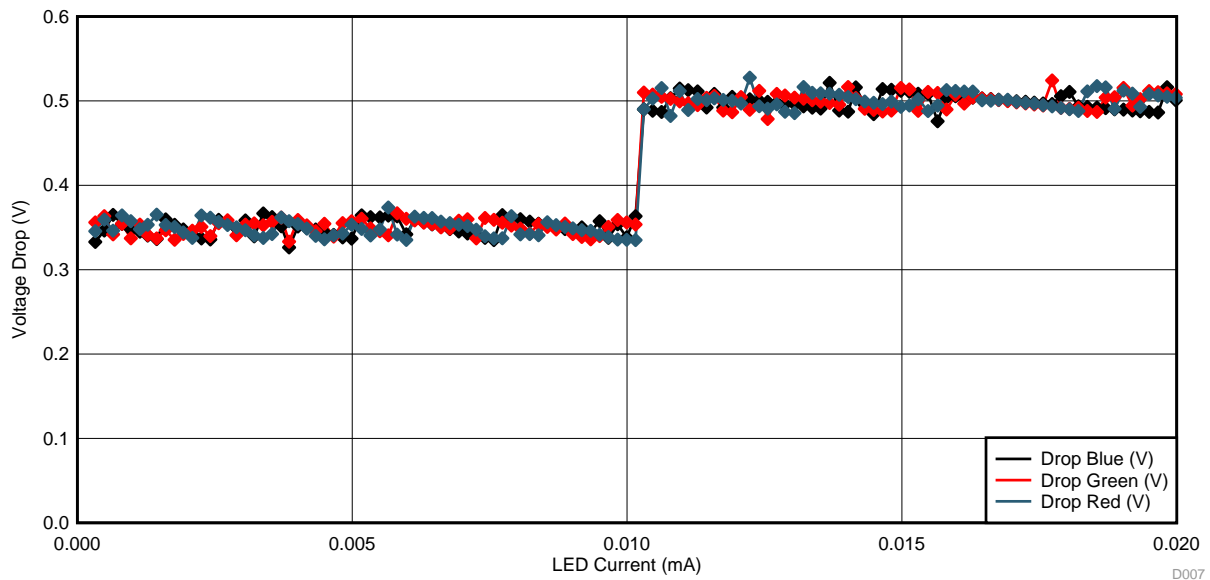
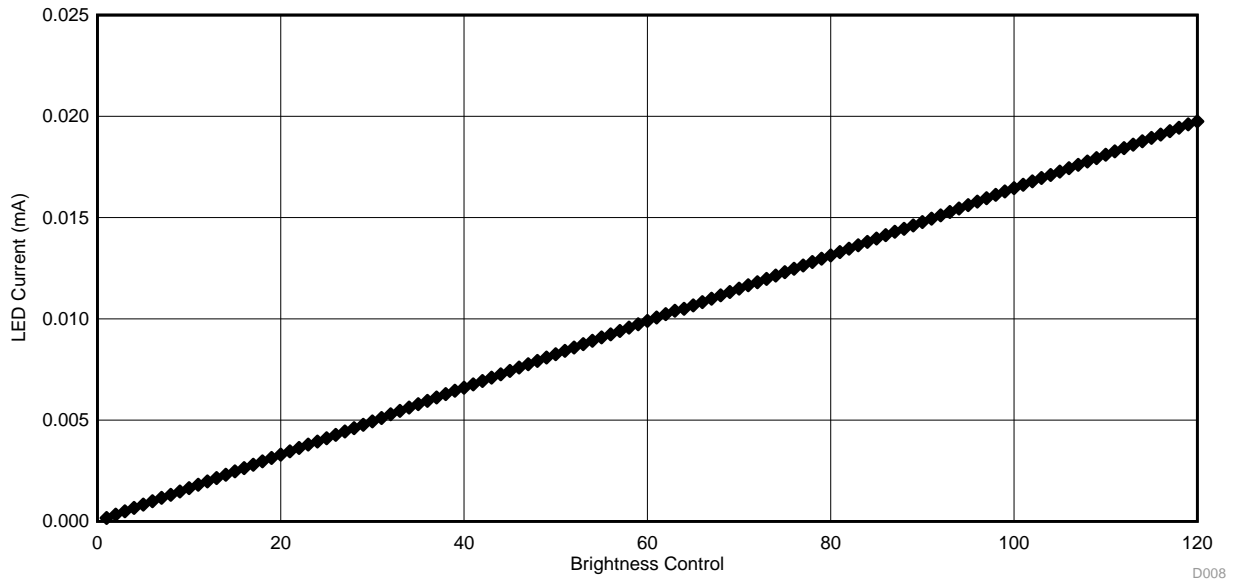

Figure 39. Brightness Control

3.2.5 Efficiency LM5166 COT and PFM

Figure 40 shows the results of the efficiency measurement of the three LM5166 on the reference design. The current on the x-axis is drawn from each LM5166. The output voltage is fixed at 4.6 V.

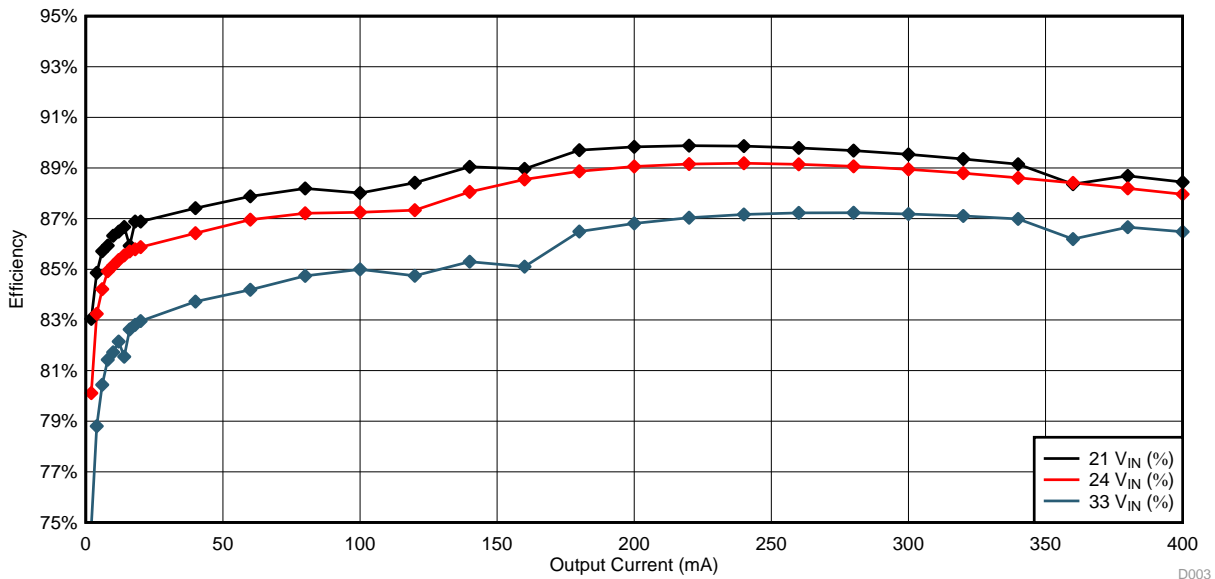

Figure 40. Efficiency of LM5166 in COT Mode

The LM5166 also supports PFM mode. The efficiency plot is shown in 図 41. The circuit of this reference design is slightly modified for this test. The inductor is replaced by 22 μH with enough current capability, the timing resistor is shorted, and the ripple generation network is removed. As expected, the efficiency is slightly below COT mode at the current here. The PFM mode has a higher efficiency than COT in low load operation, which is not applicable here.



図 41. Efficiency of LM5166 in PFM Mode

3.2.6 Loop Compensation of TPS54062

The stability of the TPS54062 is analyzed, the resulting plot is shown in 図 42. The phase is about 75° at the zero crossing of the amplitude. Therefore, it is possible to increase the bandwidth a bit further, but the regulator is in a stable condition.

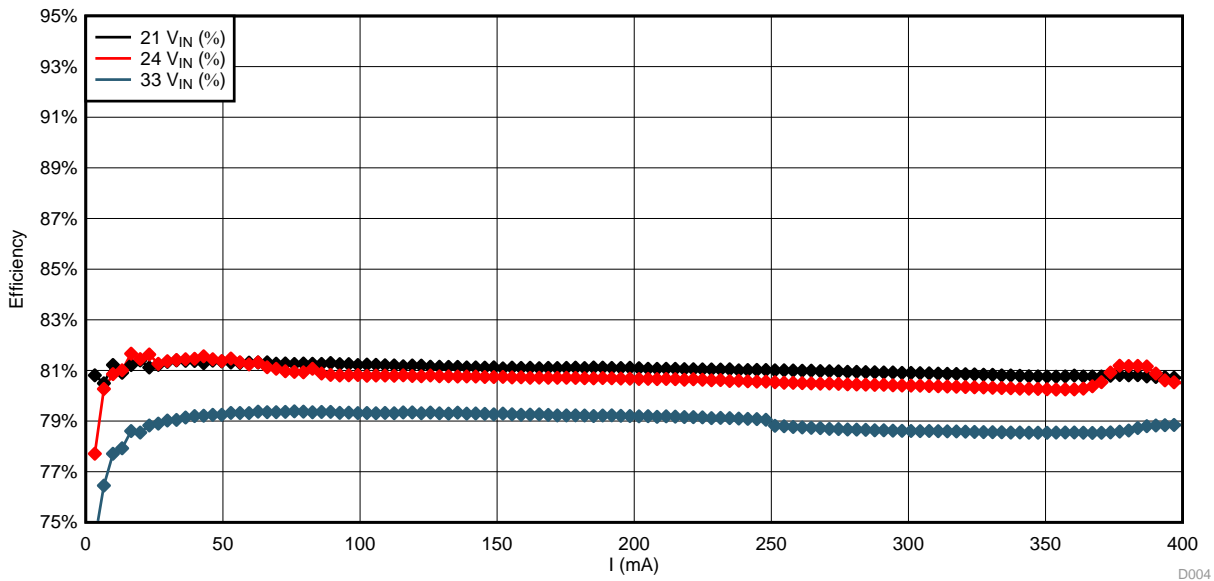

図 42. Loop Compensation of TPS54062

4 Design Files

4.1 Schematics

To download the schematics, see the design files at [TIDA-01437](#).

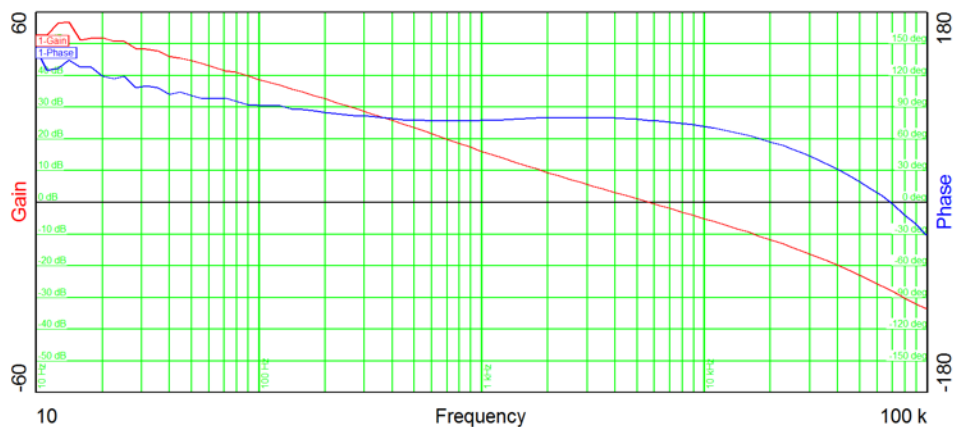
4.2 Bill of Materials

To download the bill of materials (BOM), see the design files at [TIDA-01437](#).

4.3 PCB Layout Recommendations

4.3.1 Layout Prints

To download the layer plots, see the design files at [TIDA-01437](#).

4.4 Altium Project

To download the Altium project files, see the design files at [TIDA-01437](#).

4.5 Gerber Files

To download the Gerber files, see the design files at [TIDA-01437](#).

4.6 Assembly Drawings

To download the assembly drawings, see the design files at [TIDA-01437](#).

5 Related Documentation

1. Cree, Inc. Cree PLCC6 3 in 1 SMD LED, Datasheet ([CLY6D-FKC](#))

5.1 商標

MSP430 is a trademark of Texas Instruments.
Windows is a registered trademark of Microsoft Corporation.
すべての商標および登録商標はそれぞれの所有者に帰属します。

6 About the Author

STEFFEN GRAF is a systems engineer at Texas Instruments, where he is responsible for developing reference design solutions for the industrial segment. He earned his master of science in electrical engineering at the University of applied science in Darmstadt, Germany.

TIの設計情報およびリソースに関する重要な注意事項

Texas Instruments Incorporated ("TI")の技術、アプリケーションその他設計に関する助言、サービスまたは情報は、TI製品を組み込んだアプリケーションを開発する設計者に役立つことを目的として提供するものです。これにはリファレンス設計や、評価モジュールに関する資料が含まれますが、これらに限られません。以下、これらを総称して「TIリソース」と呼びます。いかなる方法であっても、TIリソースのいずれかをダウンロード、アクセス、または使用した場合、お客様(個人、または会社を代表している場合にはお客様の会社)は、これらのリソースをここに記載された目的にのみ使用し、この注意事項の条項に従うことに合意したものとします。

TIによるTIリソースの提供は、TI製品に対する該当の発行済み保証事項または免責事項を拡張またはいかなる形でも変更するものではなく、これらのTIリソースを提供することによって、TIにはいかなる追加義務も責任も発生しないものとします。TIは、自社のTIリソースに訂正、拡張、改良、およびその他の変更を加える権利を留保します。

お客様は、自らのアプリケーションの設計において、ご自身が独自に分析、評価、判断を行う責任がお客様にあり、お客様のアプリケーション(および、お客様のアプリケーションに使用されるすべてのTI製品)の安全性、および該当するすべての規制、法、その他適用される要件への遵守を保証するすべての責任をお客様のみが負うことを理解し、合意するものとします。お客様は、自身のアプリケーションに関して、(1) 故障による危険な結果を予測し、(2) 障害とその結果を監視し、および、(3) 損害を引き起こす障害の可能性を減らし、適切な対策を行う目的で、安全策を開発し実装するために必要な、すべての技術を保持していることを表明するものとします。お客様は、TI製品を含むアプリケーションを使用または配布する前に、それらのアプリケーション、およびアプリケーションに使用されているTI製品の機能性を完全にテストすることに合意するものとします。TIは、特定のTIリソース用に発行されたドキュメントで明示的に記載されているもの以外のテストを実行していません。

お客様は、個別のTIリソースにつき、当該TIリソースに記載されているTI製品を含むアプリケーションの開発に関連する目的でのみ、使用、コピー、変更することが許可されています。明示的または黙示的を問わず、禁反言の法理その他どのような理由でも、他のTIの知的所有権に対するその他のライセンスは付与されません。また、TIまたは他のいかなる第三者のテクノロジーまたは知的所有権についても、いかなるライセンスも付与されるものではありません。付与されないものには、TI製品またはサービスが使用される組み合わせ、機械、プロセスに関連する特許権、著作権、回路配置利用権、その他の知的所有権が含まれますが、これらに限られません。第三者の製品やサービスに関する、またはそれらを参照する情報は、そのような製品またはサービスを利用するライセンスを構成するものではなく、それらに対する保証または推奨を意味するものでもありません。TIリソースを使用するため、第三者の特許または他の知的所有権に基づく第三者からのライセンス、あるいはTIの特許または他の知的所有権に基づくTIからのライセンスが必要な場合があります。

TIのリソースは、それに含まれるあらゆる欠陥も含めて、「現状のまま」提供されます。TIは、TIリソースまたはその仕様に関して、明示的か暗黙的にかかわらず、他のいかなる保証または表明も行いません。これには、正確性または完全性、権原、続発性の障害に関する保証、および商品性、特定目的への適合性、第三者の知的所有権の非侵害に対する黙示的保証が含まれますが、これらに限られません。

TIは、いかなる苦情に対しても、お客様への弁護または補償を行う義務はなく、行わないものとします。これには、任意の製品の組み合わせに関連する、またはそれらに基づく侵害の請求も含まれますが、これらに限られず、またその事実についてTIリソースまたは他の場所に記載されているか否かを問わないものとします。いかなる場合も、TIリソースまたはその使用に関連して、またはそれらにより発生した、実際の、直接的、特別、付随的、間接的、懲罰的、偶発的、または、結果的な損害について、そのような損害の可能性についてTIが知らされていたかどうかにかかわらず、TIは責任を負わないものとします。

お客様は、この注意事項の条件および条項に従わなかったために発生した、いかなる損害、コスト、損失、責任からも、TIおよびその代表者を完全に免責するものとします。

この注意事項はTIリソースに適用されます。特定の種類の資料、TI製品、およびサービスの使用および購入については、追加条項が適用されます。これには、半導体製品(<http://www.ti.com/sc/docs/stdterms.htm>)、評価モジュール、およびサンプル(<http://www.ti.com/sc/docs/sampterm.htm>)についてのTIの標準条項が含まれますが、これらに限られません。