

TI Designs: TIDA-01494 24V、公称480W、最大720W、効率93.5%超の産業用AC/DC電源 リファレンス・デザイン



概要

このリファレンス・デザインは、産業用AC/DC電源に適した小型で高効率な24V DC、公称480W、最大720W出力のリファレンス・デザインです。この回路は、フロント・エンド連続導通モード(CCM)力率補正(PFC)回路と、その後段にある、同期整流を採用した堅牢なLLC段で形成されています。このデザインは、広い負荷範囲で93.5%超の効率性を実現しているため、強制冷却なしでシステムを稼働させることができます。

UCC256301をベースにしたLLC段により、UCC256301のZCS回避機能を利用して最大出力電力を実現できるため、PFCバルク・コンデンサを最小化してホールドアップ要件を満たしながら、短絡および過電流状態に対するシステム耐性も確保できます。UCC24612-2ベースの同期整流器は、出力整流器における損失の最小化に役立ちます。

リソース

| | |
|----------------------------|------------|
| TIDA-01494 | デザイン・フォルダ |
| UCC28180 | プロダクト・フォルダ |
| UCC256301 | プロダクト・フォルダ |
| UCC24612-2 | プロダクト・フォルダ |
| TLV3202 | プロダクト・フォルダ |
| TMP302 | プロダクト・フォルダ |
| TL103W | プロダクト・フォルダ |
| TLV70433 | プロダクト・フォルダ |
| INA181 | プロダクト・フォルダ |

特長

- PFCフロント・エンドとハーフブリッジLLC共振コンバータを採用した480Wの産業用AC/DC
- 最大20Aの連続電流、3秒間にわたって最大30Aのピーク電流を供給可能
- 出力電圧を22~28Vの範囲で調整可能
- 全負荷時の総合効率は93.5%でピーク効率は94%超、自然対流冷却が可能
- 0.99を上回る高い力率で、PFC規制およびIEC 61000-3-2 Class Aの電流THD規格に準拠
- 伝導EMI規格(EN55011 Class B)に準拠
- 400mWという極めて低い無負荷消費電力
- 155x125mmの小型PCBフォーム・ファクタ
- 過電流、短絡、過電圧、出力端子におけるシステム保護により安全性を確保し、電力段の過熱保護を提供

アプリケーション

- 産業用AC/DC
- DINレール用の電源
- 医療用電源
- エネルギー・ストレージ・システム
- バッテリ充電器

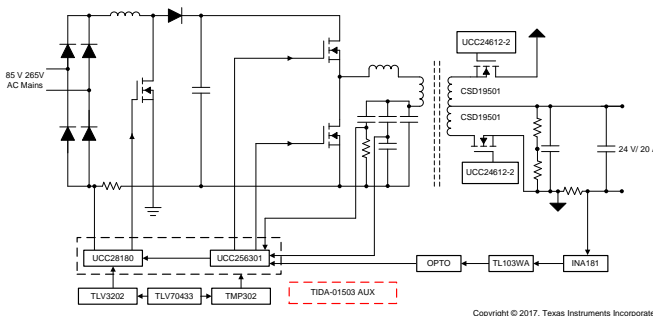
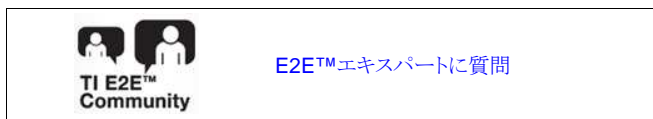



使用許可、知的財産、その他免責事項は、最終ページにあるIMPORTANT NOTICE(重要な注意事項)をご参照くださいますようお願いいたします。英語版のTI製品についての情報を翻訳したこの資料は、製品の概要を確認する目的で便宜的に提供しているものです。該当する正式な英語版の最新情報は、www.ti.comで閲覧でき、その内容が常に優先されます。TIでは翻訳の正確性および妥当性につきましては一切保証いたしません。実際の設計などの前には、必ず最新版の英語版をご参照くださいますようお願いいたします。

1 System Description

Industrial AC/DC power supplies are used in various applications such as process control, data logging, machinery control, instrumentation, factory automation, and security systems. These AC/DC supplies provide a convenient means for powering DC operated devices including programmable logic controllers (PLCs), sensors, transmitters and receivers, analyzers, motors, actuators, solenoids, relays, and so on. These supplies are convection cooled and need to support features like power boost where it supplies a increased output load for a short duration. The supplies operate over a wide input range from 85- to 265-V AC, delivering full load for entire input voltage range. The output voltages from these supplies range from 5 to 56 V with power ratings from 7.5 to 480 W. Many of these supplies can be connected in parallel for higher power applications.

This reference design is a 480-W high efficiency industrial AC/DC power supply. The design consists of a CCM boost PFC converter, which operates from an input voltage range of 85- to 265-V AC RMS and generates a 390-V DC bus. The second stage is made up of an isolated half-bridge LLC stage, which generates a 24-V, 20-A nominal output. The output voltage range is settable from 22 to 28 V using potentiometer present on the board. Industrial power supplies have requirements of high efficiency over their entire operating voltage range and wide load variations from a 50% to 100% load. This design demonstrates high efficiency operation in a small form factor (155 × 125 mm) and delivers continuous 480 W of power over the entire input operating voltage range from 85- to 265-V AC. It gives an efficiency of > 93.5% for 230-V AC nominal operation and 91% for 115-V AC nominal operation. The CCM PFC stage is controlled by the UCC28180 fixed frequency PFC device. CCM PFC offers a cost-optimized solution at this power level and wide input range. The HB-LLC power stage is controlled through the stage of the art UCC256301 resonant controller, which implements current mode control for increased control bandwidth. This increased control bandwidth reduces the output capacitors required to suppress the AC ripple on the output. To achieve high efficiency, the output of the LLC stage uses synchronous rectification based on the UCC24612 device and the CSD19501KCS MOSFET.

The design has low standby power of < 400 mW and meets ENERGY STAR® rating requirements as well as 2013 EU eco-design directive ErP Lot 6. The EMI filter is designed to meet EN55011 class-B conducted emission levels. The design is fully tested and validated for various parameters such as regulation, efficiency, EMI signature, output ripple, startup, and switching stresses. Overall, the design meets the key challenges of industrial power supplies to provide safe and reliable power with all protections built in, while delivering high performance with low power consumption and low bill of material (BOM) cost.

1.1 Key System Specifications

表 1. Key System Specifications

| PARAMETER | TEST CONDITIONS | MIN | NOM | MAX | UNIT |
|---|--|------------------------------|------|-----|------|
| INPUT CONDITIONS | | | | | |
| Input voltage (V_{INAC}) | — | 85 | 230 | 265 | VAC |
| Frequency (f_{LINE}) | — | 47 | 50 | 63 | Hz |
| No load power (P_{SB}) | — | — | 400 | — | mW |
| OUTPUT CONDITIONS | | | | | |
| Output voltage | — | 22 | — | 28 | V |
| Output current | — | — | 20 | 30 | A |
| Line regulation | Both current and voltage | — | — | 0.5 | % |
| Load regulation | Both current and voltage | — | — | 1 | % |
| Output voltage ripple | Peak to peak | — | 200 | — | mV |
| Output power (nominal) (P_o) | — | — | — | 480 | W |
| Output power (power boost) | — | — | — | 720 | W |
| SYSTEM CHARACTERISTICS | | | | | |
| Efficiency (η) | $V_{IN} = 230\text{-V AC RMS}$ and full load at 24-V output | — | 93.5 | — | % |
| | $V_{IN} = 115\text{-V AC RMS}$ and 230-W load at 24-V output | — | 91 | — | % |
| Protections | Output overcurrent | — | — | — | — |
| | Output overvoltage | — | — | — | — |
| | Output undervoltage | — | — | — | — |
| Operating ambient | Open frame | -10 | 25 | 55 | °C |
| Standards and norms | Power line harmonics | As per IEC 61000-3-2 Class A | | | |
| | Conducted emissions | EN55022 Class B | | | |
| | EFT | As per IEC-61000-4-4 | | | |
| | Surge | As per IEC-61000-4-5 | | | |
| Board form factor (FR4 material, 2 layer) | Length x Breadth x Height | 155 x 125 x 45 | | | mm |

2 System Overview

2.1 Block Diagram

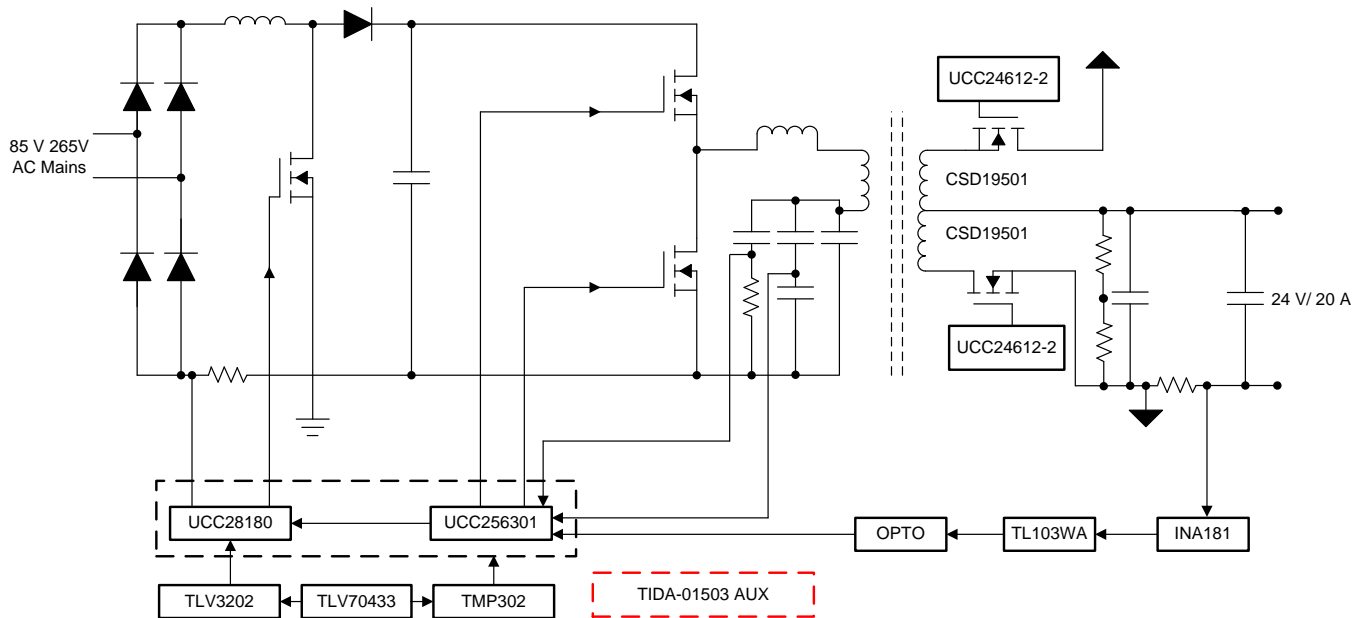

Copyright © 2017, Texas Instruments Incorporated

図 1. Block Diagram of TIDA-01494

図 1 shows the high-level block diagram of this reference design. The main parts of this design are the UCC28180 (PFC controller), UCC256301 (LLC controller), UCC24612-2 (multi-mode synchronous rectifier controller), and CSD19501KCS (80-V MOSFET).

2.2 Highlighted Products

2.2.1 UCC28180

To implement the high-performance, small form factor PFC design at 480-W power, the UCC28180 is the preferred controller because it offers a series of benefits to address the next generation needs of low THD norms for power tools.

The UCC28180 is a high-performance, CCM compact, 8-pin programmable frequency PFC controller. Its wide and programmable operating frequency provides flexibility in design. Its trimmed current loop circuits help achieve a less than 5% THD from medium-to-full load (50% to 100%). Reduced current sense threshold helps use a 50% smaller shunt resistor, resulting in lower power dissipation while maintaining low THD. Its integrated fast gate driver of +2-A/-1.5-A drive current eliminates the need for an external gate driver.

The UCC28180 also has the following system protection features, which greatly improves reliability and further simplifies the design:

- Soft overcurrent
- Cycle-by-cycle peak current limit
- Output overvoltage
- VCC UVLO protection

- Open pin protections (I_{SENSE} , V_{SENSE})

2.2.2 UCC256301

LLC resonant converters are one of the most widely used topologies for implementing medium-to-high power isolated DC/DC power stages in industrial power supplies. These converters are popular due to their ability to achieve soft-switching (ZVS turnon) for the high-voltage MOSFET, improving the overall efficiency of the system.

LLC converters in industrial power supplies do face some specific requirements. Some industrial power supplies need to support an overload (up to 1.5 times the nominal load) for a short period of time. The LLC converter must not enter the capacitive (ZCS) region during the overload operation; otherwise, it can be catastrophic. With its ZCS avoidance feature, the UCC256301 can ensure that the system does not enter the ZCS region under all operating conditions, keeping the system safe. Apart from the overload (also known as power boost) functionality, industrial power supplies typically need a tunable output voltage with a wide range. For example, in a 24-V nominal output system, the output voltage can range from 22 to 28 V. The UCC256301 provides a wide operating frequency range from 35 kHz to 1 MHz to make it easier to design wide output voltage range using an LLC converter.

The UCC256301 with its unique hybrid hysteretic control provides excellent line and load transient response, minimizing the need for output filter capacitors. Its wide frequency range can be used to reduce the PFC bulk capacitor required to meet the holdup time requirement in the industrial power supplies. With the integrated high-voltage gate drive, X-capacitor discharge function, and addition output overvoltage protection, the UCC256301 reduces the amount of external discrete components required to implement a high-efficiency industrial power supply.

2.2.3 UCC24612-2

The UCC24612-2 is a multi-mode synchronous rectifier controller for active clamp flyback and LLC applications. With its 4-A sink and 1-A source capability, the proportional gate drive of the device helps in using this synchronous rectifier in LLC applications where the system can operate above the resonant frequency. The adaptive off-time feature adds robustness to the synchronous rectifier by preventing false triggering.

2.2.4 CSD19501KCS

The CSD19501KCS is an 80-V NexFET™ with 5.5-mΩ resistance and a 38-nC gate charge. In this reference design, the CSD19501KCS is used as the synchronous FET to lower the losses in the output stage of the LLC converter.

2.3 System Design Theory

This reference design provides universal AC mains powered, 480-W nominal output at 24 V and 20 A. This design is able to support a short-time overload of up to 720 W for > 3 seconds. The UCC28180 controls a PFC boost front end, while the UCC25630 LLC resonant half-bridge converts the PFC output to an isolated 24 V and 20 A. The total system efficiency is 93.2% with a 230-V AC input and over 91% with a 110-V AC input at full load. In addition, several protections are embedded into this design, which includes input undervoltage protection and output short-circuit protection.

Low EMI, high efficiency, a high power factor, and reliable power supply are the main focus of this design for targeted applications.

2.3.1 PFC Regulator Stage Design

For high power levels such as 500 W, either the single-phase CCM PFC or interleaved CrCM PFC can be preferred. CCM PFC has certain advantages at these power levels, such as a lower component count, reduced input peak currents, and simpler EMI filter requirements. CrCM PFC requires smaller PFC inductors and can use ultrafast diode for the PFC boost diode. CrCM PFC also have the advantage of enabling valley switching and ZCS turnon condition for the PFC MOSFET.

In this design, the CCM PFC is used as it enables a fixed frequency PFC implementation with reduced input peak currents, which helps reduce the cost.

The UCC28180 operates at fixed frequency in CCM mode and requires minimal external components for high-wattage PFC pre-regulator implementation. The design process and component selection for this design are illustrated in the following subsections.

2.3.1.1 Design Parameters

表 2. Design Parameters for PFC Power Stage Design

| PARAMETER | | MIN | TYP | MAX | UNIT |
|----------------|--------------------------|-----|------|-----|------|
| INPUT | | | | | |
| V_{IN} | Input voltage | 85 | — | 265 | VAC |
| f_{LINE} | Input frequency | 47 | — | 63 | Hz |
| OUTPUT | | | | | |
| V_{OUT} | Output voltage | — | 391 | | VDC |
| $P_{OUT(nom)}$ | Output power | — | — | 500 | W |
| $P_{OUT(max)}$ | Output power | — | — | 750 | W |
| — | Line regulation | — | — | 5 | % |
| — | Load regulation | — | — | 5 | % |
| PF | Targeted power factor | — | 0.99 | — | — |
| η | Targeted efficiency | — | 97.5 | — | % |
| f_{sw} | Mean switching frequency | — | 70 | — | kHz |

2.3.1.2 Current Calculations

The input fuse, bridge rectifier, and input capacitor are selected based upon the input current calculations. First, determine the maximum average output current, $I_{OUT(max)}$:

$$I_{OUT(max)} = \frac{P_{OUT(max)}}{V_{OUT(max)}} \quad (1)$$

$$I_{OUT(max)} = \frac{500}{390} = 1.28$$

The maximum input RMS line current, $I_{INrms(max)}$, is calculated using the parameters from 表 2 and the efficiency and power factor initial assumptions:

$$I_{INrms(max)} = \frac{P_{OUT(max)}}{\eta \times V_{IN(max)} \times PF} \quad (2)$$

$$I_{INrms(max)} = \frac{500}{0.94 \times 85 \times 0.99} = 6.32$$

2.3.1.3 Boost Inductor

To dimension the boost inductor, first calculate the maximum allowed ripple current. The maximum ripple current is observed at the lowest input voltage and maximum load. Assuming a maximum 25% ripple in the inductor current gives a ripple current:

$$I_{N\text{ripple(max)}} = \Delta\text{RIPPLE} \times I_{N\text{rms(max)}} \quad (3)$$

$$I_{N\text{ripple(max)}} = 0.25 \times \sqrt{2} \times 6.32 = 2.23$$

The duty cycle, $DUTY_{(\text{max})}$, at the peak of the minimum input voltage can be calculated as:

$$DUTY_{(\text{max})} = \frac{V_{\text{OUT(max)}} - V_{\text{INrms(min)}} \times \sqrt{2}}{V_{\text{OUT(max)}}} \quad (4)$$

$$DUTY_{(\text{max})} = \frac{390 - (1.414 \times 85)}{390} = 0.691$$

The minimum value of the boost inductor is calculated based upon the acceptable ripple current, $I_{N\text{ripple(max)}}$, at a worst case duty cycle of 0.691:

$$L_{\text{Boost}} \geq V_{\text{OUT(max)}} \times DUTY_{(\text{max})} \times \frac{(1 - DUTY_{(\text{max})})}{f_{\text{SW}} \times I_{\text{RIPPLE(max)}}} \quad (5)$$

$$L_{\text{Boost}} \geq \frac{390 \times 0.691 \times (1 - 0.691)}{(950000 \times 2.23)} \geq 392 \mu\text{H}$$

The actual value of the boost inductor used is 420 μH .

The required saturation current for the boost inductor is calculated using 式 6 for the minimum input voltage and short-time maximum overload conditions.

$$I_{L(\text{max})} = \left(\sqrt{2} \times \frac{P_{\text{OUT(max)}}}{V_{\text{INrms(min)}}} \right) \times \left(1 + \frac{\Delta\text{RIPPLE}}{2} \right) = 11.3 \quad (6)$$

2.3.1.4 Output Capacitor

The output capacitor, C_{OUT} , is sized to meet the holdup requirements of the converter. The holdup time required by this design, T_{Holdup} , is 20 ms. During this time, the minimum voltage that the PFC output can reach at full load is designed to be $V_{\text{OUT(min)}} = 290 \text{ V}$. Substituting the known values in 式 7, the minimum C_{OUT} is:

$$C_{\text{OUT}} \geq 2 \times P_{\text{OUT(nom)}} \times \frac{T_{\text{Holdup}}}{V_{\text{OUT(max)}}^2 - V_{\text{OUT(min)}}^2} \quad (7)$$

$$C_{\text{OUT(min)}} \geq \frac{2 \times 500 \times 20 \text{ ms}}{(390^2 - 290^2)} = 294 \mu\text{F}$$

The capacitor of 330 μF is selected for use in this reference design.

2.3.1.5 Switching Element

The drain-to-source RMS current, I_{DSrms} , through the PFC MOSFET is calculated as:

$$I_{\text{DSrms}} = \frac{P_{\text{OUT(nom)}}}{\sqrt{2} \times V_{\text{INrms(min)}}} \times \sqrt{2 - \frac{16 \times V_{\text{INrms}} \times \sqrt{2}}{3 \times \pi \times V_{\text{OUT(max)}}}} \quad (8)$$

$$I_{DSrms} = \frac{500}{120} \times \sqrt{2 - \left(\frac{16 \times 120}{3\pi \times 390} \right)} = 5.05$$

Select a MOSFET with a low figure of merit for this application. The key specifications that are important for this topology are:

- Low R_{DSon} , for reducing the conduction losses in the MOSFET
- Low Q_G , for fast turnon and turnoff, both of which are hard switched in this topology
- Low output capacitance, to reduce C_{OSS} related losses

2.3.1.6 Boost Diode

The output diode must have a blocking voltage that exceeds the output overvoltage of the converter and average current same as $I_{OUT(max)}$. In CCM PFC topology, the boost diode undergoes hard turnoff and hence suffers from reverse recovery losses.

One way of reducing the reverse recovery loss is by using a silicon-carbide diode. In this design, the TRS6E65F diode is used.

2.3.1.7 Sense Resistor

To accommodate the gain of the nonlinear power limit, the sense resistor, R_{SENSE} , is sized such that it triggers the soft overcurrent at 10% higher than the maximum peak inductor current using the minimum soft overcurrent threshold of the ISENSE pin, V_{SOC} , of ISENSE equal to 0.265 V.

$$R_{SENSE} = \frac{V_{SOC(min)}}{I_{L(max)} \times 1.1} \tag{9}$$

$$R_{SENSE} = \frac{0.259 \text{ V}}{11.3 \text{ A} \times 1.1} = 0.02 \Omega = R41$$

2.3.1.8 Control Loop Compensation

The voltage error amplifier is compensated with a zero, f_{ZERO} , at the f_{PWM_PS} pole, and a pole, f_{POLE} , is placed at 20 Hz to reject high-frequency noise and roll off the gain amplitude. The overall voltage loop crossover, f_v , is desired to be at 10 Hz. The compensation components of the voltage error amplifier are selected accordingly.

2.3.2 LLC Converter Stage Design

The DC/DC stage in an industrial AC/DC converter needs to support a wide output voltage range and a hold up time > 20 ms. Combined with the need to meet the short time power boost feature, the LLC-based DC/DC stage needs to be designed with sufficient gain and proper operating point to maximize efficiency.

Because this DC/DC stage supports a nominal output power of 480 W and a peak output power of 720 W, designing the DC/DC stage for 720-W operation does not give an optimum performance at 480 W. While designing for 480 W, take care in dimensioning the resonant tank components such that the system does not enter into the capacitive region of operation at 720 W.

The hybrid hysteretic mode control and ZCS avoidance of the UCC256301 helps in developing a robust LLC power stage for use in these applications.

表 3. Design Parameters for LLC Power Stage Design

| PARAMETER | | MIN | TYP | MAX | UNIT |
|----------------------|-----------------------------|-----|------|-----|------|
| INPUT | | | | | |
| V_{INDC} | Input voltage | 300 | 397 | 410 | VDC |
| OUTPUT | | | | | |
| V_{OUT} | Output voltage | — | 24 | — | VDC |
| P_{LIMIT} | Output power limit | — | — | 720 | W |
| P_{OUT} | Max output power | — | 480 | — | W |
| $f_{\text{SW(nom)}}$ | Nominal switching frequency | — | 80 | — | kHz |
| — | Line regulation | — | 1 | — | % |
| — | Load regulation | — | 1 | — | % |
| η | Targeted efficiency | — | 0.97 | — | — |

2.3.2.1 Determine M_g (Voltage Gain)

The transformer turns ratio is determined by 式 10.

$$n = M_g \times \frac{V_{\text{DCIN(nom)}}}{2V_0} \quad (10)$$

Where M_g is the voltage gain ($M_g = 0.9$).

From these specifications, the nominal values for input voltage and output voltage are 390 V and 24 V, respectively. As a result, the turns ratio can be calculated as:

$$n = M_g \times \left(\frac{V_{\text{DCIN(nom)}}}{2V_0} \right) = 7.32 \quad (11)$$

2.3.2.1.1 Determine $M_{g(\min)}$ and $M_{g(\max)}$

$M_{g(\min)}$ and $M_{g(\max)}$ can be determined by using 式 12 and 式 13, respectively:

$$M_{g(\min)} = n \times \left(\frac{V_{0(\min)}}{2V_{\text{DCIN(max)}}} \right) \quad (12)$$

$$M_{g(\min)} = 7.32 \times \left(\frac{22 \text{ V}}{2 \times 410 \text{ V}} \right) = 0.766$$

$$M_{g(\max)} = n \times \left(\frac{V_{0(\max)}}{2V_{\text{DCIN(min)}}} \right) \quad (13)$$

$$M_{g(\max)} = 7.32 \times \left(\frac{\frac{28 \text{ V}}{300 \text{ V}}}{2} \right) = 1.366$$

The dimensioned $M_{g(\max)}$ is increased to 1.1 times the required value to handle the power boost functionality = $M_{g(\max)} = 1.1 \times 1.366 \approx 1.5$.

2.3.2.2 Determine Equivalent Load Resistance (R_e) of Resonant Network

The equivalent load resistance at nominal and peak load under nominal output voltage and peak output voltage are derived in this section.

$$R_e = \frac{8 \times n^2}{\pi^2} \times \left(\frac{V_{0(\text{nom})}}{I_{0(\text{nom})}} \right) \quad (14)$$

$$R_{e(\text{nom})} = \frac{8 \times 7.7^2}{\pi^2} \times \left(\frac{24}{20} \right) = 57.7 \, \Omega$$

Under peak load conditions of 30 A at a 24-V output, the equivalent load resistance is given by 式 15:

$$R_{e_pk} = \frac{8 \times n^2}{\pi^2} \times \left(\frac{V_{0(\text{nom})}}{I_{0_pk}} \right) \quad (15)$$

$$R_{e_pk} = \frac{8 \times 7.7^2}{\pi^2} \times \left(\frac{24}{20} \right) = 38.48 \, \Omega$$

Similarly, the equivalent load resistance at the maximum output voltage is $V_{O_pk} = 28 \, \text{V}$.

$$R_{e(\text{maxV})} = \frac{8 \times 7.7^2}{\pi^2} \times \left(\frac{28}{17.2} \right) = 78.31 \, \Omega \quad (16)$$

2.3.2.3 Select L_m/L_r Ratio (L_n) and Q_e

The second resonance point for the LLC converter is set at close to 75 kHz. By choosing a value of $L_r = 47 \, \mu\text{H}$ and $C_r = 94 \, \text{nF}$, calculate the value of the resonant frequency to be using 式 17:

$$F_r = \frac{1}{2 \times \pi \sqrt{L_r \times C_r}} = 75.75 \, \text{kHz} \quad (17)$$

The magnetizing inductance to resonant inductance ratio is chosen as 6 to develop sufficient gain while minimizing the magnetizing current in the LLC transformer. By using an integrated magnetics approach, the L_r is realized as the leakage inductor of the main LLC transformer.

The Q curves for this design at different corner conditions are depicted in 図 2. The corner conditions operate at a 28-V output with 480-W output power and at 24-V output with 720-W peak power. The Q curve for the 24-V output and 480-W output power is also plotted for reference.



図 2. Q Curves at Various Normal and Boundary Operating Conditions

2.3.2.4 Determine Primary-Side Currents

The primary-side RMS load current (I_{PRI}) at full load is determined from 式 18:

$$I_{pri} = \frac{\pi}{2\sqrt{2}} \times \left(\frac{I_o}{n} \right) \quad (18)$$

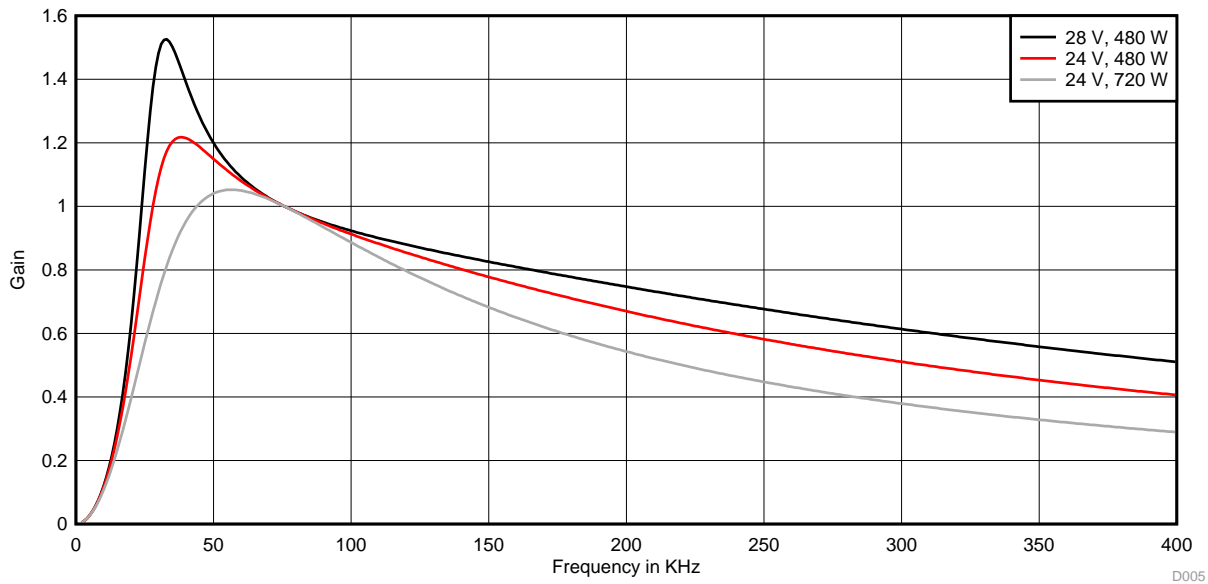
$$I_{pri} = 1.11 \times \left(\frac{20}{7.7} \right) = 2.883$$

The RMS magnetizing current (I_M) at $f_{SW(min)} = 50$ kHz is determined from 式 19:

$$I_m = \left(\frac{2\sqrt{2}}{\pi} \right) \times \left(\frac{7.7 \times 28}{2 \times \pi \times 50 \text{ kHz} \times 280 \mu\text{H}} \right) = 2.202 \quad (19)$$

The resonant circuit's current (I_r) is determined from 式 20:

$$I_r = \sqrt{I_m^2 + I_{pri}^2} \quad (20)$$

$$I_r = \sqrt{2.883^2 + 2.202^2} = 3.63$$

This is also the transformer's primary winding current at $f_{SW(min)}$.

2.3.2.5 Determine Secondary-Side Currents

The secondary-side RMS currents can be calculated from the average load current:

$$I_{sec} = 20 \quad (21)$$

Assuming the LLC power stage is operating at close to its second resonant frequency, the average current through each rectifier in the secondary-side push-pull output is given as:

$$I_{sec_avg} = 10 \quad (22)$$

The corresponding half-wave RMS current is:

$$I_{sec_rms} = I_{sec} \times \frac{\pi}{4} = 15.7 \quad (23)$$

2.3.2.6 Select Primary Side MOSFETs

Each MOSFET sees the input voltage as its maximum applied voltage:

$$V_{DS} = 1.2 \times V_{INDC(max)} = 1.2 \times 410 = 492 \text{ V} \rightarrow 500 \quad (24)$$

For the LLC power stage to work in ZVS, the turnon losses can be neglected. Choose the MOSFET based on R_{DS_ON} and C_{OSS} . Optimizing C_{OSS} helps in minimizing the dead time required for achieving ZVS, thereby minimizing duty cycle loss.

For this design, the IPP60R190P6 MOSFET is used. The UCC256301's adaptive dead-time optimization feature helps in maximizing the duty cycle, which improves efficiency.

2.3.2.7 Select Secondary-Side MOSFETs

The diode rectifier voltage rating is determined as:

$$V_{DS\ max_sec} = 1.2 \times 2 V_{OUT(max)} = 1.2 \times 2 \times 28 = 67.2 \quad (25)$$

The MOSFET's current rating is determined as:

$$I_{sec_rms} = 15.7 \quad (26)$$

TI's 80-V NexFET CSD19501KCS with its low R_{DS_ON} ($< 5.5 \text{ m}\Omega$) and Q_g ($< 38 \text{ nC}$) is used in this reference design. The very low R_{DSon} of the TI NexFET helps in reducing the overall loss in the synchronous rectifier.

2.3.3 Components for UCC256301 Controller

This section explains the selection of certain components for the LLC power stage controlled by the UCC256301.

2.3.3.1 Soft Start

The UCC256301 is configured to give a maximum of a 400-ms soft start period. During startup, the soft-start capacitor is charged using the 25- μA current source internally. The UCC256301 exits soft start when the closed loop control takes over or when the voltage on the soft-start capacitor reaches 7 V. The value of the soft-start capacitor is selected using 式 27.

$$C_{SS} = C31 = 400 \text{ ms} \times \frac{25 \mu\text{A}}{7 \text{ V}} = 1.5 \mu\text{F} \quad (27)$$

2.3.3.2 Current Sense Circuit

The overcurrent limit OCP3 is set to trigger at 1.2 times the peak overload capability of the system.

$$V_{ISNSFullload} = \frac{OCP3}{1.2} = \frac{0.6}{1.2} = 0.5 \quad (28)$$

The current sense ratio is then calculated as:

$$K_{ISNS} = \frac{V_{ISNSFullload}}{\left(\frac{P_{OUT(max)}}{\eta}\right) \times \left(\frac{1}{V_{Bulk}}\right)} = \frac{0.5}{(757) \times \left(\frac{1}{390}\right)} = 0.257 \quad (29)$$

Select the current sense capacitor using:

$$C_{ISNS} = C39 = 150 \text{ p} \quad (30)$$

As a result:

$$R_{\text{ISNS}} = R3 = K_{\text{ISNS}} \times \frac{C_r}{C_{\text{ISNS}}} = 0.257 \times \frac{94 \times 10^{-9}}{150 \times 10^{-12}} = 161 \quad (31)$$

The R3 is selected as 162 Ω .

2.3.3.3 Overvoltage Protection (BW Pin)

The BW pin senses the output voltage through the bias winding mounted on the LLC transformer. This pin can be used to provide an additional overvoltage protection in the system. In this reference design, the bias winding has 0.6 times the turns of the secondary winding, and the overvoltage protection is set at 35 V. At this point, the bias winding voltage is at 21 V. Now the BW pin potential divider is set in such a way that it sees 4 V at a 35-V output.

Use 式 32 to select:

$$R_{\text{BWLLOWER}} = R12 = 10 \quad (32)$$

As a result:

$$R_{\text{BWUPPER}} = R17 = R12 \times \frac{21 \text{ V} - 4 \text{ V}}{4 \text{ V}} = 42.5 \quad (33)$$

2.3.4 Bias Power Supply

The [TIDA-01503 reference design](#), a 20-W auxiliary power supply based on the UCC28704, is used in this reference design to provide the bias power to the PFC, LLC, SR, and other logic circuits on the board. The converter is powered from the output of the PFC pre-regulator stage and must be able to start up prior to the PFC stage being operational. For this reason, the circuit is designed to operate over a wide input voltage, 100- to 450-V DC. The flyback transformer has three output windings, which are isolated to each other.

3 Hardware, Testing Requirements, and Test Results

3.1 Required Hardware

3.1.1 Test Conditions

For input conditions:

- V_{IN} : 85- to 265-V AC
- I_{IN} : Current limit to 8 A

For output conditions:

- V_{OUT} : 22 to 28 V
- I_{OUT} : 0 to 20 A (nominal), 30-A overload

3.1.2 Equipment Needed

- Isolated AC source
- Single-phase power analyzer
- Digital oscilloscope
- Multimeters
- Electronic load

3.1.3 Procedure

1. Adjust the R77 potentiometer to set for a 24-V output.
2. Connect input terminals (connector J3) of the reference board to the AC power source.
3. Connect output terminals (connector J2) to electronic load, maintaining correct polarity.
4. Set minimum load of about 50 mA.
5. Gradually increase the input voltage from 0 V to a turnon voltage of 85-V AC. As the input voltage crosses 85 V, the PFC section starts working and boost the PFC output to 390-V DC.
6. Observe the startup conditions for smooth switching waveforms.
7. As the PFC output voltage crosses 310 V, the LLC section starts working and the output voltage is developed.

3.2 Testing and Results

3.2.1 Efficiency and Regulation

This section shows the efficiency, power factor, iTHD, and load regulation results at 115-V and 230-V AC input conditions.

The following figures show the graphs for efficiency, power factor, iTHD, and load regulation, respectively.



図 3. Efficiency Data



図 4. Power Factor Data

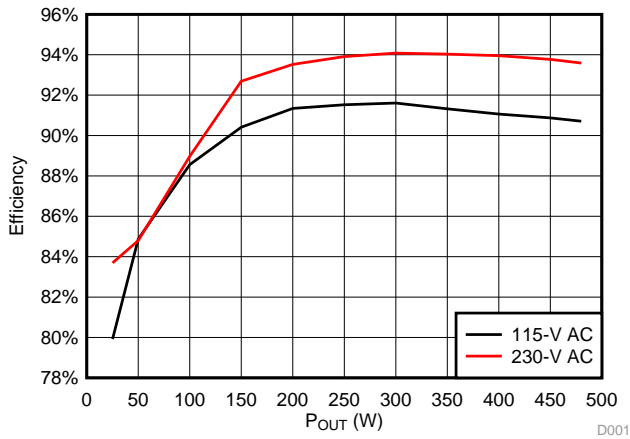

図 5. iTHD Data

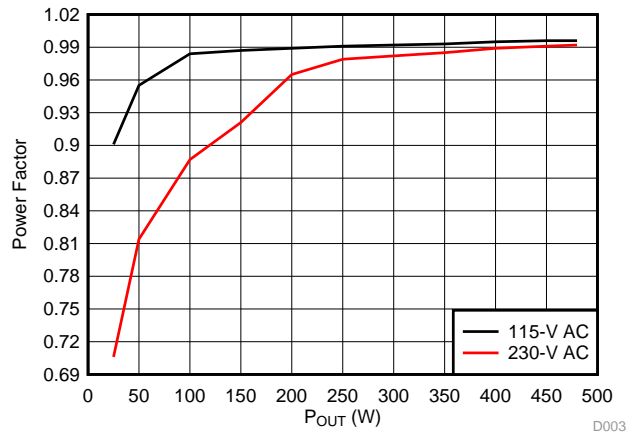

図 6. Load Regulation Data

3.2.2 Startup Waveform

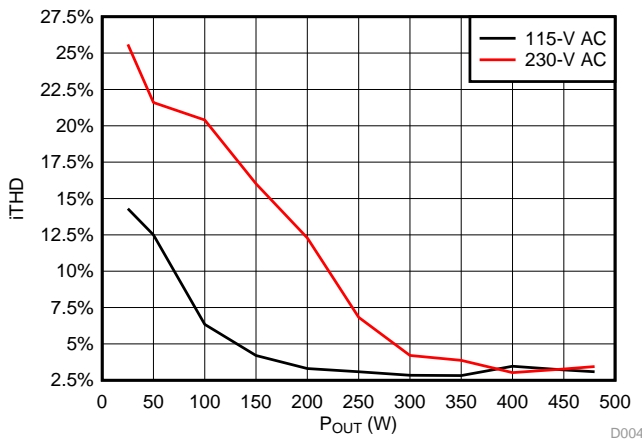
The startup waveform showing the 24-V output voltage and the input AC current is shown in [Fig. 7](#). [Fig. 8](#) shows the same waveform zoomed in.

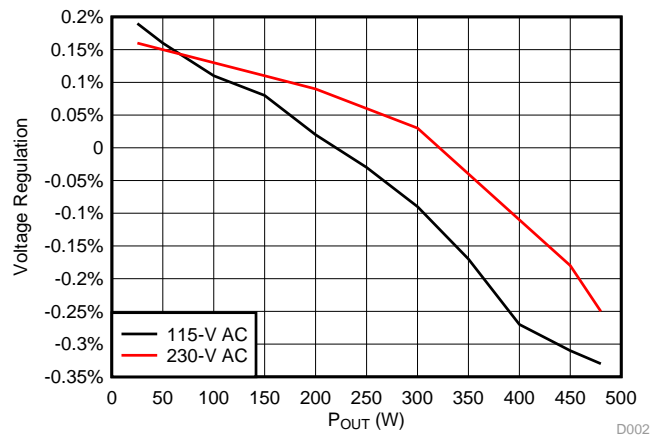

図 7. Startup Waveform at 230-V AC



図 8. Startup Waveform at 230-V AC (Zoomed In)

3.2.3 Load Transient Response

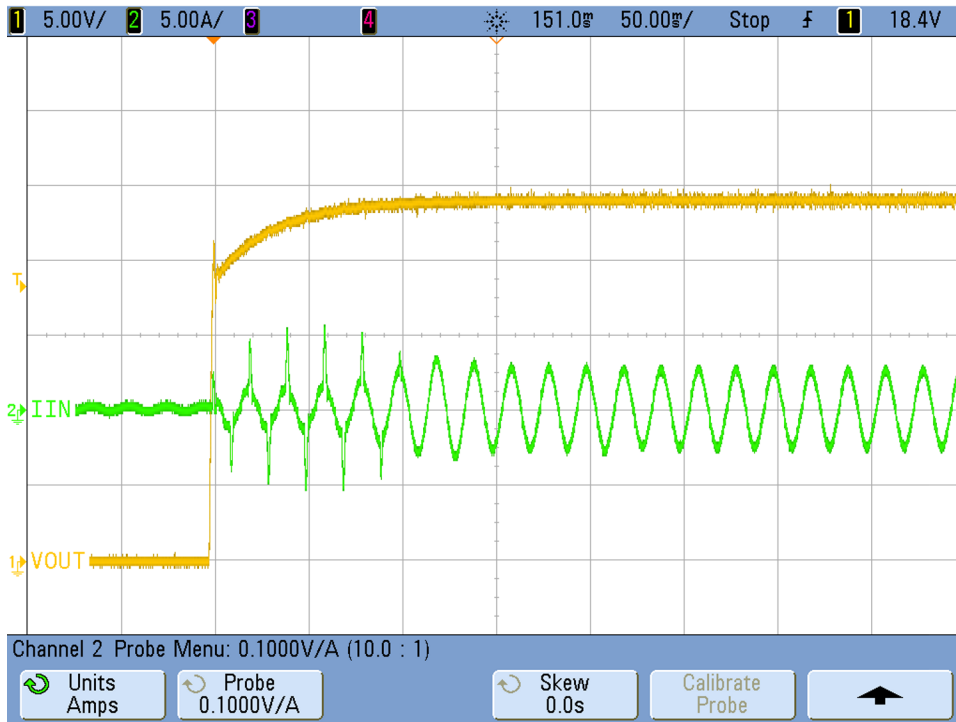
Figure 9 shows the transient response of the system when the 24-V output load varies from 4 to 20 A at a slew rate of 500 mA/μC. The maximum dip is 200 mV on the 24-V output.

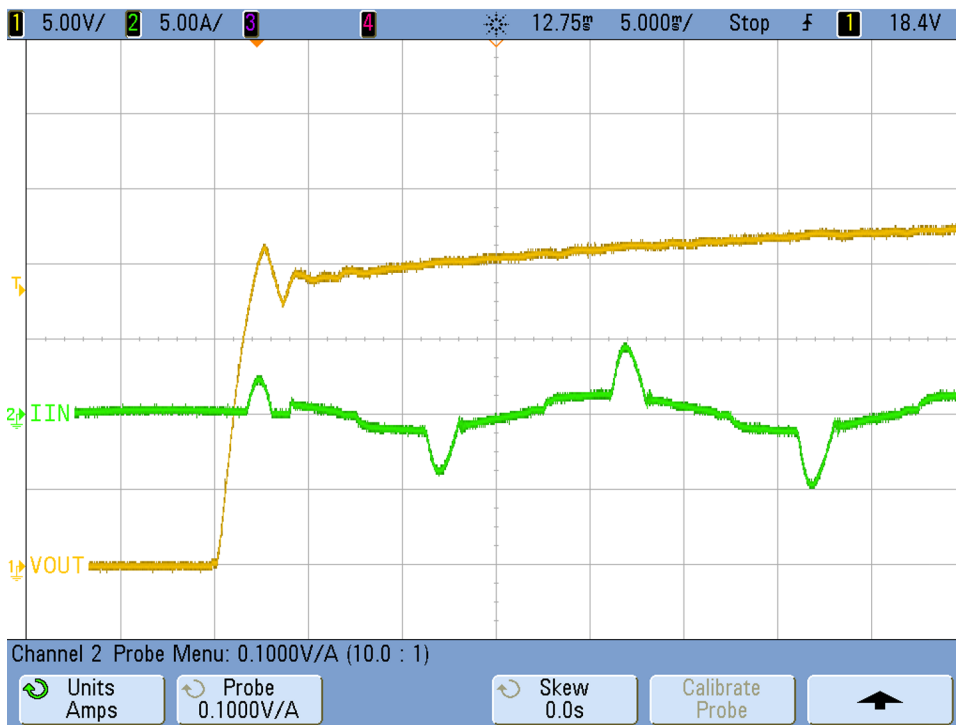
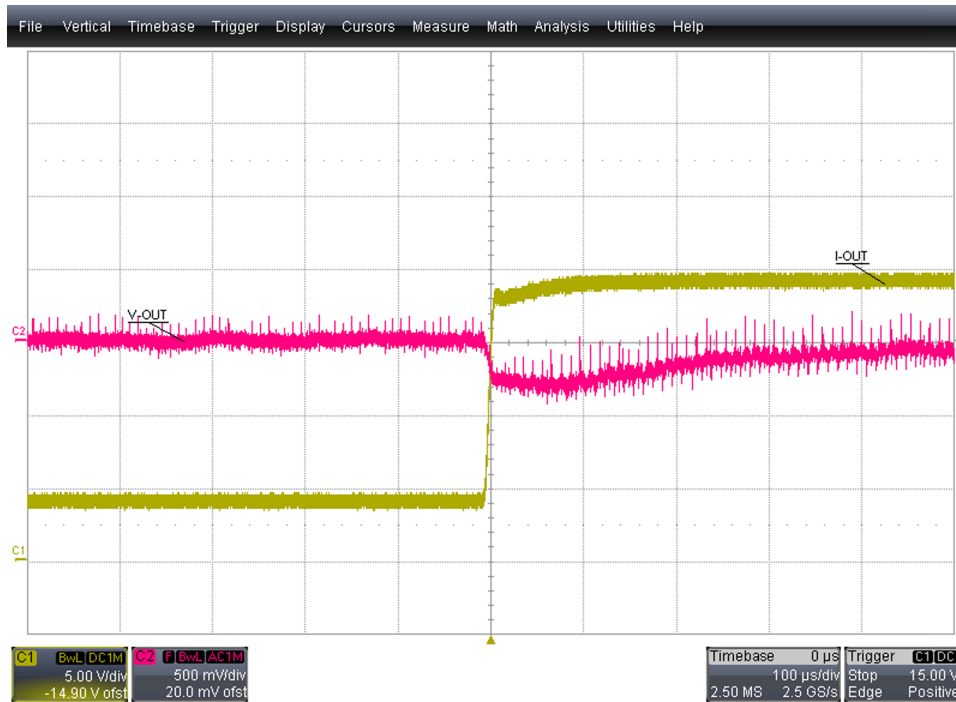

Figure 9. Transient Response at 24-V Output

3.2.4 PFC MOSFET Switching Waveforms

This sections shows the PFC MOSFET turnon and turnoff switching waveforms in [Fig 10](#) and [Fig 11](#), respectively.

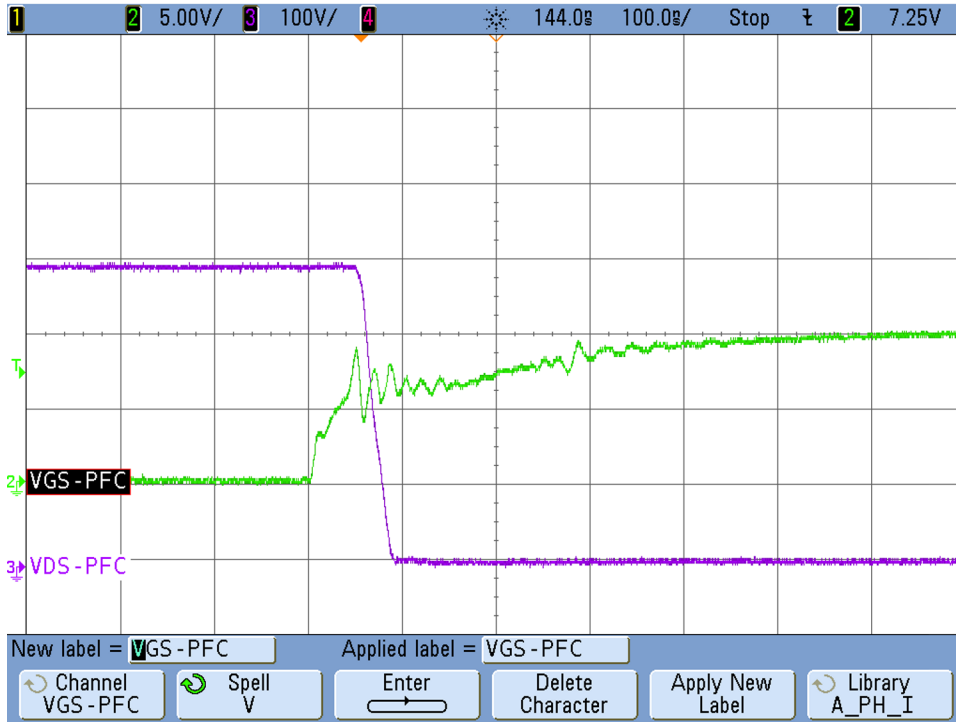

Fig 10. PFC MOSFET Turnon Waveform

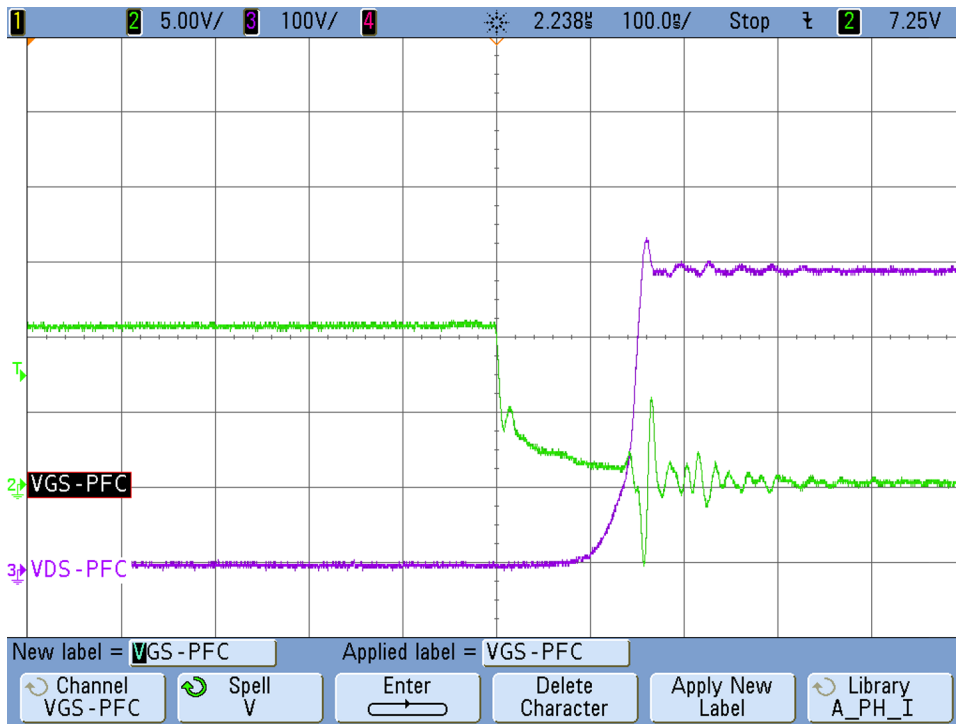

Fig 11. PFC MOSFET Turnoff Waveform

3.2.5 LLC Primary-Side Switching Waveform

The primary-side switching waveform of the LLC stage depicting the tank current and low-side PWM is shown in [Figure 12](#).

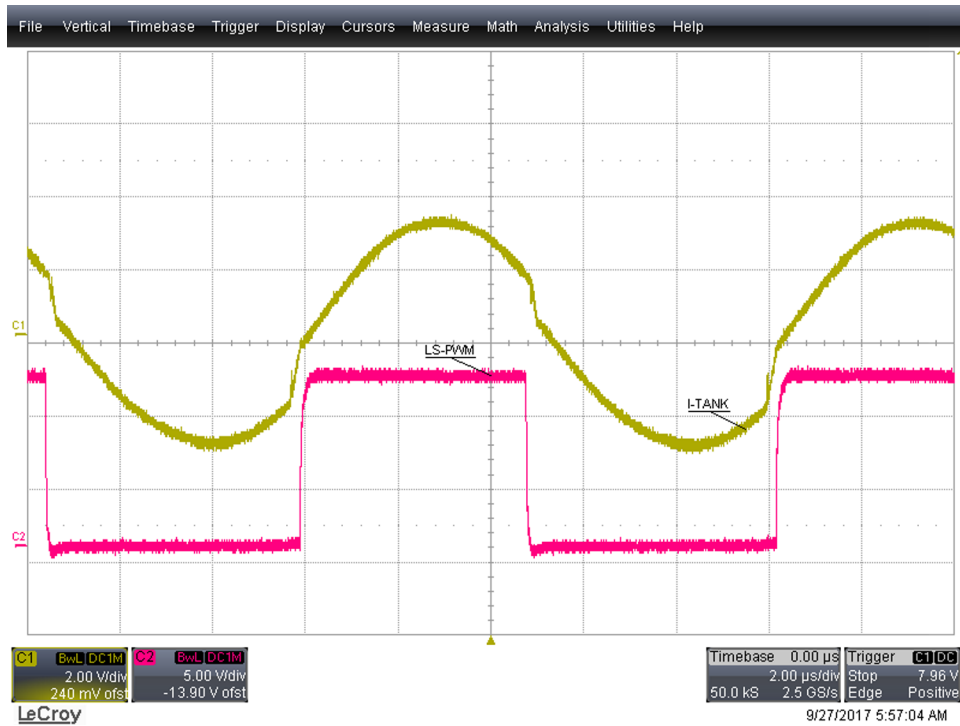

Figure 12. LLC Tank Current and Low-Side PWM

3.2.6 LLC Secondary-Side Synchronous Drive Waveform

The synchronous MOSFET and the synchronous drive output waveforms are shown in the following figures. [Fig 13](#) shows the V_{DS} of the synchronous MOSFET and the proportional gate drive output of the UCC24612-2. [Fig 14](#) and [Fig 15](#) show the zoomed-out synchronous MOSFET turnon and turnoff waveforms, respectively. The synchronous driver turns the synchronous MOSFET on within 150 ns of its body diode conducting and it turns off slightly before and intentionally lets the body diode conduct for a short period so as to avoid shoot-through and current reversal.

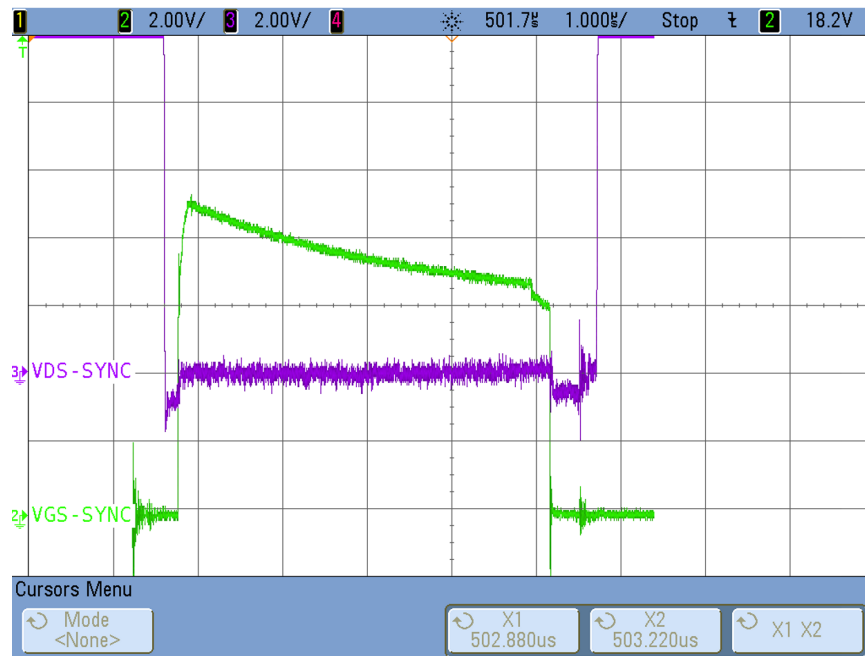

Fig 13. Synchronous MOSFET V_{DS} and Proportion Gate Drive Signal

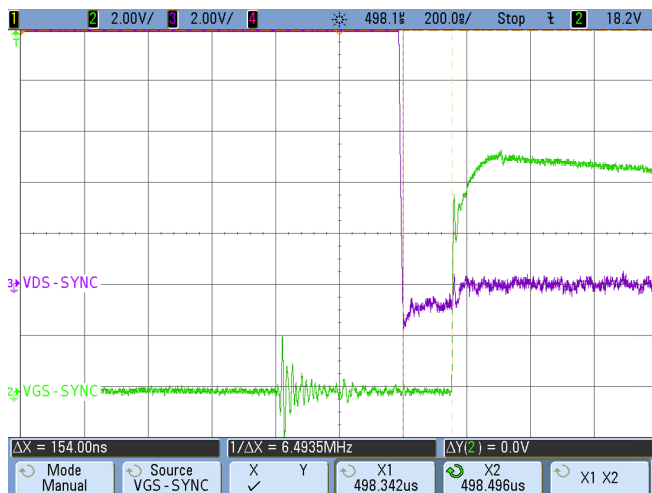

Fig 14. Synchronous MOSFET Turnon

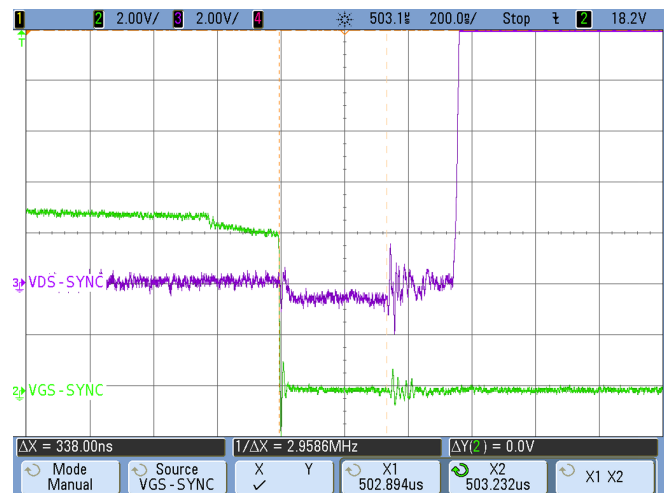

Fig 15. Synchronous MOSFET Turnoff

3.2.7 Short-Time 720-W Peak Output

The output power capability of the short-time peak is shown in [Figure 16](#).



図 16. 720-W Peak Output Power Capability at 24-V Output

For 3 seconds, the system can support up to 720 W. Do not continuously load this reference design beyond 480 W.

3.2.8 Thermal Image

The thermal image of the board working at full load under natural convection cooling is shown in [Figure 17](#).

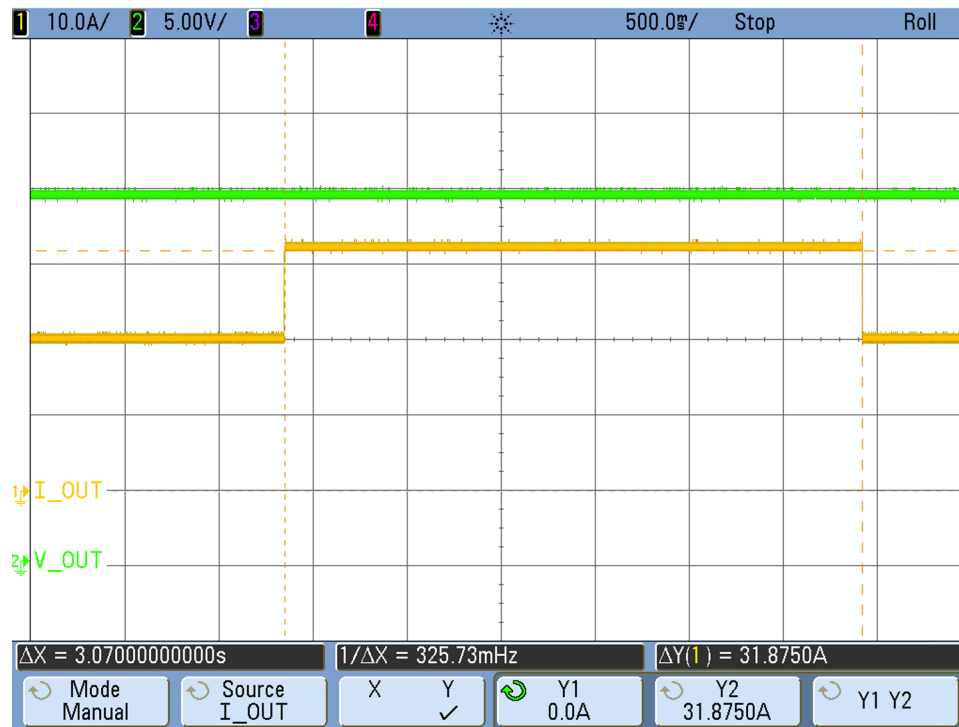
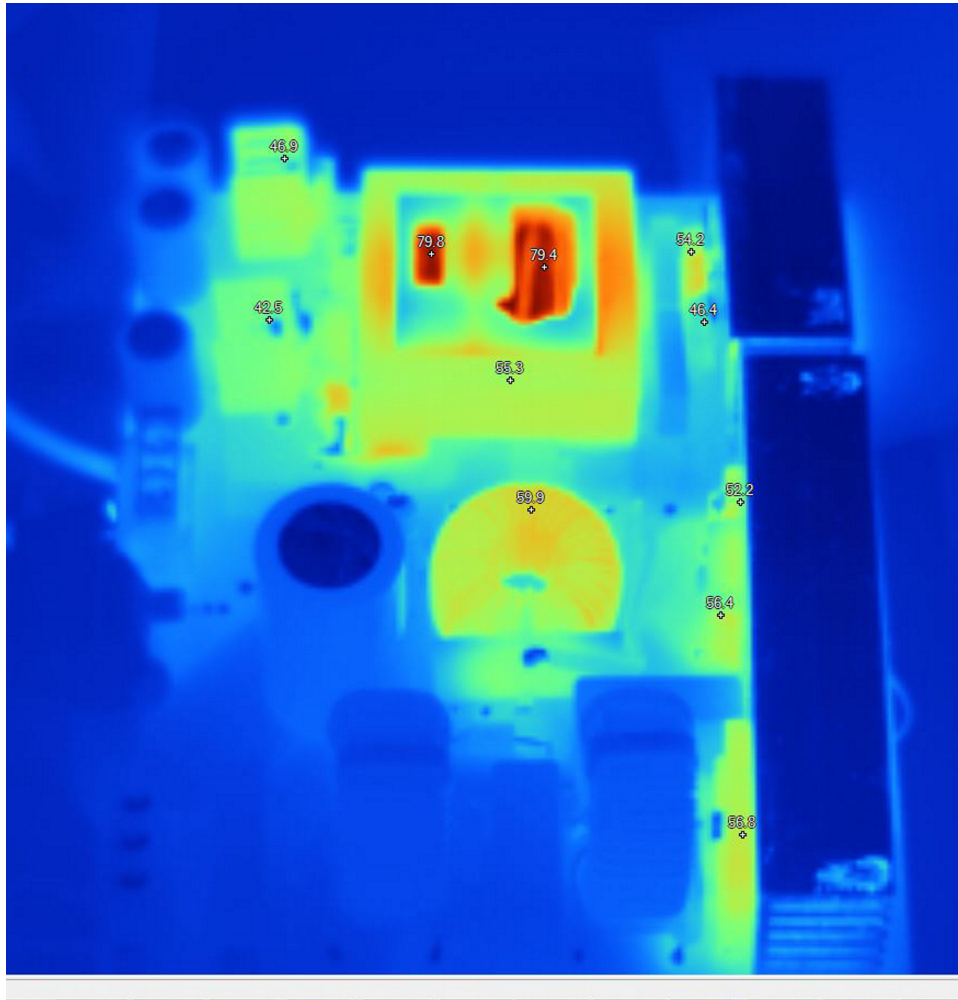

Figure 17. Thermal Image at 230-V AC Input and 480-W Load

[Table 4](#) shows the temperature on the main components on the board.

Table 4. Temperature of Major Components at 230-V AC, 480-W Output

| COMPONENT | TEMPERATURE |
|---------------------------|---|
| Diode bridge | 56.8°C |
| PFC MOSFET | 56.4°C |
| PFC diode | 52.2°C |
| HB-LLC HV MOSFET | 54.2°C, 46.4°C |
| HB-LLC synchronous MOSFET | 46.9°C, 42.5°C |
| PFC choke | 59.9°C |
| HB-LLC transformer | 79.8°C (secondary), 79.4°C (primary), 55.3°C (core) |

4 Design Files

4.1 Schematics

To download the schematics, see the design files at [TIDA-01494](#).

4.2 Bill of Materials

To download the bill of materials (BOM), see the design files at [TIDA-01494](#).

4.3 PCB Layout Recommendations

4.3.1 Layout Prints

To download the layer plots, see the design files at [TIDA-01494](#).

4.4 Altium Project

To download the Altium project files, see the design files at [TIDA-01494](#).

4.5 Gerber Files

To download the Gerber files, see the design files at [TIDA-01494](#).

4.6 Assembly Drawings

To download the assembly drawings, see the design files at [TIDA-01494](#).

5 Software Files

To download the software files, see the design files at [TIDA-01494](#).

6 Related Documentation

1. Texas Instruments, [Designing an LLC Resonant Half-Bridge Power Converter](#), Power Supply Design Seminar (SLUP263)
2. Texas Instruments, [Feedback Loop Design of an LLC Resonant Power Converter](#), Application Report (SLUA582)
3. Texas Instruments, [UCC256301 Hybrid Hysteretic Mode Wide VIN LLC Resonant Controller Enabling Ultra-Low Standby Power](#), Datasheet (SLUSCU6)

6.1 商標

E2E, NexFET are trademarks of Texas Instruments.

ENERGY STAR is a registered trademark of U.S. Environmental Protection Agency.

すべての商標および登録商標はそれぞれの所有者に帰属します。

7 About the Author

RAMKUMAR S is a systems engineer at Texas Instruments, where he is responsible for developing reference design solutions for the industrial segment. Ramkumar brings his diverse experience in analog and digital power supplies design to this role. Ramkumar earned his master of technology (M.Tech) from the Indian Institute of Technology in Delhi.

TIの設計情報およびリソースに関する重要な注意事項

Texas Instruments Incorporated ("TI")の技術、アプリケーションその他設計に関する助言、サービスまたは情報は、TI製品を組み込んだアプリケーションを開発する設計者に役立つことを目的として提供するものです。これにはリファレンス設計や、評価モジュールに関係する資料が含まれますが、これらに限られません。以下、これらを総称して「TIリソース」と呼びます。いかなる方法であっても、TIリソースのいずれかをダウンロード、アクセス、または使用した場合、お客様(個人、または会社を代表している場合にはお客様の会社)は、これらのリソースをここに記載された目的にのみ使用し、この注意事項の条項に従うことに合意したものとします。

TIによるTIリソースの提供は、TI製品に対する該当の発行済み保証事項または免責事項を拡張またはいかなる形でも変更するものではなく、これらのTIリソースを提供することによって、TIにはいかなる追加義務も責任も発生しないものとします。TIは、自社のTIリソースに訂正、拡張、改良、およびその他の変更を加える権利を留保します。

お客様は、自らのアプリケーションの設計において、ご自身が独自に分析、評価、判断を行う責任がお客様にあり、お客様のアプリケーション(および、お客様のアプリケーションに使用されるすべてのTI製品)の安全性、および該当するすべての規制、法、その他適用される要件への遵守を保証するすべての責任をお客様のみが負うことを理解し、合意するものとします。お客様は、自身のアプリケーションに関して、(1) 故障による危険な結果を予測し、(2) 障害とその結果を監視し、および、(3) 損害を引き起こす障害の可能性を減らし、適切な対策を行う目的での、安全策を開発し実装するために必要な、すべての技術を保持していることを表明するものとします。お客様は、TI製品を含むアプリケーションを使用または配布する前に、それらのアプリケーション、およびアプリケーションに使用されているTI製品の機能性を完全にテストすることに合意するものとします。TIは、特定のTIリソース用に発行されたドキュメントで明示的に記載されているもの以外のテストを実行していません。

お客様は、個別のTIリソースにつき、当該TIリソースに記載されているTI製品を含むアプリケーションの開発に関連する目的でのみ、使用、コピー、変更することが許可されています。明示的または黙示的を問わず、禁反言の法理その他どのような理由でも、他のTIの知的所有権に対するその他のライセンスは付与されません。また、TIまたは他のいかなる第三者のテクノロジーまたは知的所有権についても、いかなるライセンスも付与されるものではありません。付与されないものには、TI製品またはサービスが使用される組み合わせ、機械、プロセスに関連する特許権、著作権、回路配置利用権、その他の知的所有権が含まれますが、これらに限られません。第三者の製品やサービスに関する、またはそれらを参照する情報は、そのような製品またはサービスを利用するライセンスを構成するものではなく、それらに対する保証または推奨を意味するものでもありません。TIリソースを使用するため、第三者の特許または他の知的所有権に基づく第三者からのライセンス、もしくは、TIの特許または他の知的所有権に基づくTIからのライセンスが必要な場合があります。

TIのリソースは、それに含まれるあらゆる欠陥も含めて、「現状のまま」提供されます。TIは、TIリソースまたはその仕様に関して、明示的か暗黙的にかかわらず、他のいかなる保証または表明も行いません。これには、正確性または完全性、権原、続発性の障害に関する保証、および商品性、特定目的への適合性、第三者の知的所有権の非侵害に対する黙示的保証が含まれますが、これらに限られません。

TIは、いかなる苦情に対しても、お客様への弁済または補償を行う義務はなく、行わないものとします。これには、任意の製品の組み合わせに関連する、またはそれらに基づく侵害の請求も含まれますが、これらに限られず、またその事実についてTIリソースまたは他の場所に記載されているか否かを問わないものとします。いかなる場合も、TIリソースまたはその使用に関連して、またはそれらにより発生した、実際の、直接的、特別、付随的、間接的、懲罰的、偶発的、または、結果的な損害について、そのような損害の可能性についてTIが知らされていたかどうかにかかわらず、TIは責任を負わないものとします。

お客様は、この注意事項の条件および条項に従わなかったために発生した、いかなる損害、コスト、損失、責任からも、TIおよびその代表者を完全に免責するものとします。

この注意事項はTIリソースに適用されます。特定の種類の資料、TI製品、およびサービスの使用および購入については、追加条項が適用されます。これには、半導体製品(<http://www.ti.com/sc/docs/stdterms.htm>)、評価モジュール、およびサンプル(<http://www.ti.com/sc/docs/sampterms.htm>)についてのTIの標準条項が含まれますが、これらに限られません。