

TI Designs: TIDA-01418

HVAC A/Cコンプレッサ用の車載、高電圧、大電力モータ・ドライブのリファレンス・デザイン



概要

このブラシレスDC (BLDC)モータのデザインは、UCC27712-Q1ハイサイドおよびローサイド・ゲート・ドライバと、それに続くディスクリート絶縁ゲート・バイポーラ・トランジスタ(IGBT)ハーフ・ブリッジを使用し、車載用HVAC A/Cコンプレッサを制御するソリューションです。このリファレンス・デザインは、TIのC2000 Piccolo F2805xマイクロコントローラと、InstaSPIN™-FOCセンサレス・モータ制御ソリューションを使用します。このソリューションでは、モータのパラメータ識別、電流ループの自動チューニング、および重負荷でのスタートアップや超低速制御といった高性能のセンサレス動作が可能になります。InstaSPINを利用することで、このTI Designではコンプレッサのダイナミック・レンジが増大し、コンプレッサは低い速度(500rpm)で最大トルク動作が可能です。これによって、HVACの動作時にEVのバッテリーを節約できます。設計者は、InstaSPINをPiccolo™マイクロコントローラ(MCU)の読み取り専用メモリ(ROM)にある特別なライブラリを使用して有効にでき、センサレス(速度およびトルク)モータ制御アプリケーション用の専門的なツールを使用できます。

リソース

TIDA-01418	デザイン・フォルダ
UCC27712-Q1	プロダクト・フォルダ
LM5160-Q1	プロダクト・フォルダ
TPS7B6733-Q1	プロダクト・フォルダ
TPS7B6750-Q1	プロダクト・フォルダ
TCAN1042HGV-Q1	プロダクト・フォルダ
ISO7733-Q1	プロダクト・フォルダ
TMS320F28052F	プロダクト・フォルダ
SN74LVC2G74-Q1	プロダクト・フォルダ
SN74LVC541A-Q1	プロダクト・フォルダ
LMT87-Q1	プロダクト・フォルダ
OPA365-Q1	プロダクト・フォルダ
TLV314-Q1	プロダクト・フォルダ
LMV393-Q1	プロダクト・フォルダ

特長

- 低電圧側は最高45V、バッテリー逆極性の状況、および負荷ダンプ状況(12Vシステム)に耐えられる
- 次の機能を使用して、過電流および誤検出によるターンオンへの保護機能を内蔵
 - アクティブ・ミラー・クランプ
 - 過電流検出回路
- 絶縁CAN通信インターフェイス
- ピーク出力2.5A、非絶縁型、低コストのハイサイド/ローサイド・ゲート・ドライバ
- 絶縁型電源
- 小型のレイアウト
- 車載の温度および品質向けに選択された部品
- InstaSPIN、センサレス・トルク制御アルゴリズム

アプリケーション

- [車載用HVACコンプレッサHEV/EV](#)



[E2E™エキスパートに質問](#)

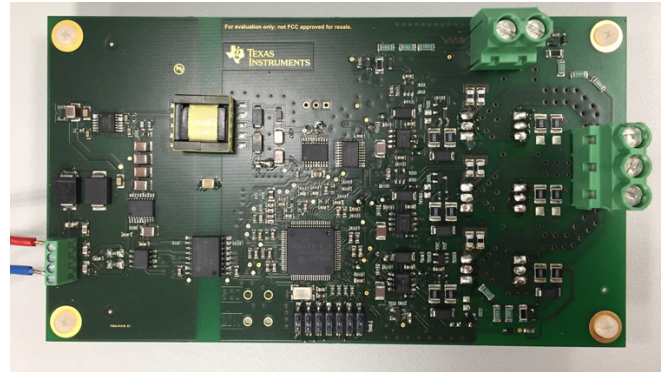
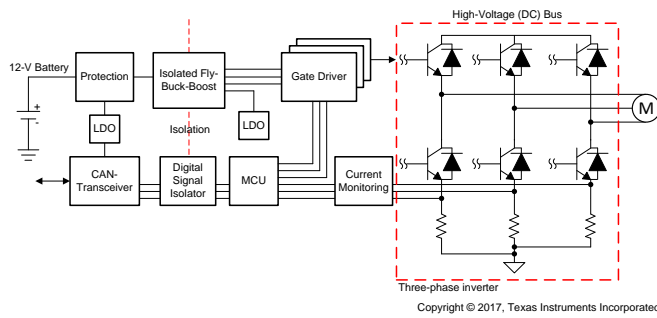

使用許可、知的財産、その他免責事項は、最終ページにあるIMPORTANT NOTICE(重要な注意事項)をご参照くださいますようお願いいたします。英語版のTI製品についての情報を翻訳したこの資料は、製品の概要を確認する目的で便宜的に提供しているものです。該当する正式な英語版の最新情報は、www.ti.comで閲覧でき、その内容が常に優先されます。TIでは翻訳の正確性および妥当性につきましては一切保証いたしません。実際の設計などの前には、必ず最新版の英語版をご参照くださいますようお願いいたします。

1 System Description

One of the core features of hybrid electric vehicles (HEVs) is the idle-stop or stop-start system. When an HEV vehicle starts to idle at a traffic light, the system shuts down the engine. This shutdown indicates that no power is available to drive the A/C compressor. To solve this issue, most hybrid and all electric vehicles (EVs) have an electric drive for the compressor. An electric motor is built in the compressor and is driven by an inverter, which the high-voltage battery of the vehicle supplies. The IGBTs in the inverter carry high currents, which is why such applications typically use a lot of isolated components (gate driver, analog-to-digital converter (ADC)) that add delay in the switching circuit and make the solution more expensive. Another cost factor is the rotation detection of the motor, which the designer can accomplish within some circuits by implementing a resolver or through the use of a couple of Hall sensors.

The TIDA-01418 is a three-phase inverter drive which is based on a discrete IGBT for driving brushless DC (BLDC) motors in automotive A/C compressors using sensorless torque control.

The TIDA-01418 system consists of an:

- Isolated power supply
- Isolated communication interface (CAN)
- Non-isolated IGBT gate driver circuit
- Non-isolated current monitoring and overcurrent detecting circuit
- TMS320F28052 microcontroller

The main goal when creating this reference design was to reduce the number of isolated components, add a few safety features in the hardware (overcurrent detection), and maintain a small and compact design.

1.1 Key System Specifications

表 1. Key System Specifications

PARAMETER	SPECIFICATIONS
DC bus input voltage	Max 450 V
Supply voltage (12-V battery)	6.5 V to 18 V

表 1. Key System Specifications (continued)

PARAMETER	SPECIFICATIONS	
Gate driver supply voltage	16 V	
Rated power capacity	4 kW (max load current 12 A)	
Non-isolated IGBT gate driver	Supply voltage	10 V to 20 V
	Current sink and source	2.5 A/1.75 A
	Turnon propagation delay	100 ns to 160 ns
	Turnoff propagation delay	100 ns to 160 ns
Controller	TMS320F28052	
Digital signal isolation	ISO7731 reinforced	
Power supply specification for MCU and digital logic	3.3 V \pm 2%	
Feedbacks	DC bus voltage, IGBT temperature, motor phase voltage, and motor phase current	
Protections	12-V battery side	Reverse polarity
		Transient voltage
		ESD
	High-voltage side	DC bus undervoltage and overvoltage ⁽¹⁾
		Overcurrent ⁽²⁾
		Overtemperature (IGBT) ⁽³⁾

⁽¹⁾ Software protection

⁽²⁾ Hardware circuit (overcurrent protection) also realized in software

⁽³⁾ Software protection

2 System Overview

2.1 Block Diagram

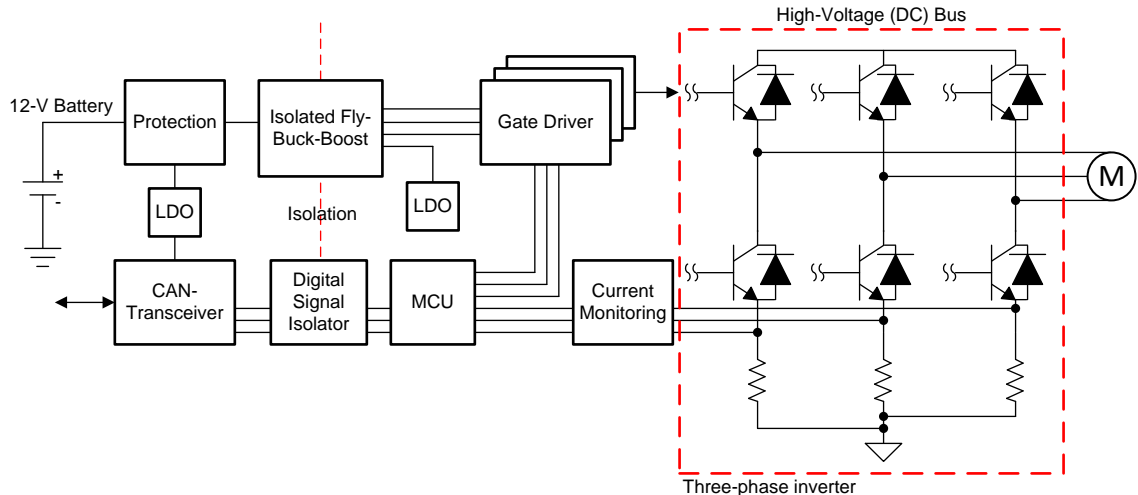
AC compressors typically use three-phase BLDC motors that are built in the compressor, driven by an inverter, and supplied by the high-voltage battery of the vehicle.  1 shows the block diagram of the three-phase inverter with an isolated power supply and isolated interface between the MCU and CAN transceiver.

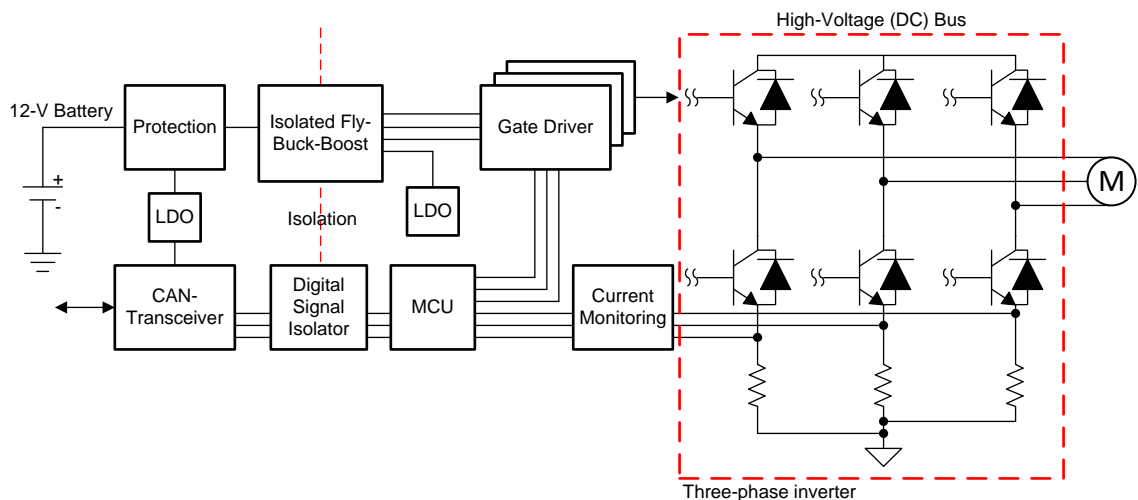

Copyright © 2017, Texas Instruments Incorporated

図 1. TIDA-01418 Block Diagram

The whole system is represented in ten blocks:

- Low-voltage side (12-V battery)
 - Protection: Protects circuit against reverse battery and load dump condition
 - Low dropout regulator (LDO): Supplies the CAN transceiver with 5 V
 - CAN transceiver: Communication interface
- High-voltage side
 - Microcontroller (MCU): TI's C2000™ family of MCUs with InstaSPIN algorithm controls the motor torque, performs all other calculations, and manages communication through the CAN transceiver
 - Current monitoring: Circuit monitors the current in each phase of the inverter and detects the overcurrent condition
 - IGBTs: Delivers the current for the three-phase motor
 - Gate drivers: Controlled by the MCU; each gate driver is capable of driving the gates of the high- and low-side IGBTs
 - LDO: Supplies the MCU and all other logic components on the "hot" side (high-voltage side)
- Isolation barrier
 - Isolated fly-buck-boost converter: Delivers supply voltage over isolation barrier to the gate driver and all other logic components
 - Digital signal isolator: Isolates the interface between the MCU and CAN transceiver

2.2 Highlighted Products

2.2.1 LM5160-Q1

The LM5160-Q1 is TI's synchronous Buck/Fly-Buck™ converter with a wide input voltage range. This device is capable of handling input voltages up to 65 V and has integrated high-side and low-side MOSFETs. An internal feedback amplifier maintains $\pm 1\%$ output voltage regulation over the entire operating temperature range. The soft-start feature allows the converter to gradually reach a steady-state operation point, thereby reducing start-up stresses and current surges. The LM5160 contains a dual-level undervoltage lockout (EN/UVLO) circuit. When the EN/UVLO pin voltage is below 0.35 V, the regulator is in low-current shutdown mode. When the EN/UVLO pin voltage is greater than 0.35 V (typically) but less than 1.24 V (typically), the regulator is in standby mode. In standby mode, the V_{CC} bias regulator is active but the converter switching remains disabled. When the voltage at the VCC pin exceeds the V_{CC} rising threshold $V_{CC}(UV) = 3.98$ V (typically) and the EN/UVLO pin voltage is greater than 1.24 V, normal switching operation begins. The designer can use an external resistor voltage divider from VIN to GND to set the minimum operating voltage of the regulator. Operate the LM5160 device such that the junction temperature does not exceed 150°C during normal operation. An internal thermal shutdown circuit has been provided to protect the LM5160 device in the event that the junction temperature rises higher than normal. When activated, typically at 175°C, the controller is forced into a low-power reset state, which disables the high-side buck switch and the V_{CC} regulator. This feature prevents failures from accidental device overheating. When the junction temperature falls below 155°C (typical hysteresis = 20°C), the V_{CC} regulator is enabled and operation resumes.

The main features of this device are as follows:

- Device temperature grade 1: -40°C to 125°C ambient operating temperature range
- Wide 4.5-V to 65-V input voltage range
- Integrated high- and low-side switches
 - No Schottky diode required
- 1.5-A maximum load current
- Programmable soft-start time
- Peak current limiting protection
- Adjustable input UVLO and hysteresis
- $\pm 1\%$ feedback voltage reference
- Thermal shutdown protection

2.2.2 TPS7B6750-Q1 and TPS7B6733-Q1

The TPS7B6750-Q1 and TPS7B6733-Q1 devices are LDOs designed for up to 40-V input voltage range operations. These devices have only 15- μA quiescent current at a light load. The TPS7B750/33 drives loads up to 450 mA. In the TPS7B67xx-Q1 family of devices, the designer can implement the reset delay signal and power-good signal during power up to indicate that the output voltage is stable and is in regulation. An external capacitor programs the delay. By using the MCU I/O port, the designer can also control the enable function, which activates or deactivates the device.

The main features of these devices are as follows:

- Device temperature grade 1: -40°C to 125°C ambient operating temperature range
- 4-V to 40-V wide V_{IN} input-voltage range with up to 45-V transient

- Maximum output current: 450 mA
- Low quiescent current (I_Q): 15 μ A typical at light loads
- Maximum dropout voltage: 450 mV at 400 mA
- Integrated fault protection:
 - Thermal shutdown
 - Short-circuit protection

2.2.3 TCAN1042-Q1

The TCAN1042-Q1 transceiver meets the ISO11898-2:2016 high-speed CAN physical layer standard. The device is designed for use in CAN FD networks up to 2 Mbps. This device has a low-power standby mode with a feature for remote wake-up request. Additionally, the TCAN1042-Q1 includes many protection features which enhance the network and device robustness.

The main features of this device are as follows:

- Meets the December 17th, 2015 draft of ISO11898-2 Physical Layer Update
- Junction temperatures from -55°C to 150°C
- Meets the released ISO 11898-2:2007 and ISO11898-2:2003 Physical Layer Standards
- I/O voltage range supports 3.3-V and 5-V MCUs
- Receiver common-mode input voltage: ± 30 V
- Typical loop delay: 110 ns
- Protection features
 - HBM ESD protection: ± 16 kV
 - IEC ESD protection up to ± 15 kV
 - Bus fault protection: ± 58 V (non-H variants) and ± 70 V (H variants)
 - Undervoltage protection on V_{CC} and VIO (V-variants only) supply terminals
 - Driver dominant time out (TXD DTO) – Data rates down to 10 kbps
 - Thermal shutdown protection (TSD)

2.2.4 ISO7731-Q1

The ISO7731-Q1 device is high-performance, triple-channel digital isolator with 5000 V_{RMS} (DW package) and 2500 V_{RMS} (DBQ package) isolation ratings per UL 1577. This device has reinforced insulation rating according to VDE, CSA, TUV, and CQC. The ISO7731-Q1 provides high electromagnetic immunity and low emissions at a low power consumption, while isolating CMOS or LVCMOS digital I/Os. Each isolation channel has a logic input and output buffer separated by a silicon dioxide (SiO_2) insulation barrier. This device comes with enable pins which the designer can use to put the respective outputs in high impedance for multi-master driving applications and to reduce power consumption. The ISO7730-Q1 device has all three channels in the same direction and the ISO7731-Q1 device has two forward and one reverse-direction channel. If the input power or signal is lost, the default output is high for devices without suffix F and low for devices with suffix F. Used in conjunction with isolated power supplies, this device helps prevent noise currents on a data bus or other circuits from entering the local ground and interfering with or damaging sensitive circuitry.

The main features of this device are as follows:

- Device temperature grade 1: -40°C to $+125^{\circ}\text{C}$ ambient operating temperature
- Signaling rate: Up to 100 Mbps
- Wide supply range: 2.25 V to 5.5 V
- 2.25-V to 5.5-V level translation
- Low-power consumption, typical 1.5 mA per channel at 1 Mbps
- Low propagation delay: 11 ns typical (5-V supplies)
- High common-mode transient immunity (CMTI): $\pm 100\text{ kV}/\mu\text{s}$ typical
- Isolation barrier life: > 40 years
- Robust electromagnetic compatibility (EMC)
 - System-level electrostatic discharge (ESD), electrical fast transient (EFT), and surge immunity
 - Low emissions

2.2.5 TMS320F28052

The F2805x Piccolo™ family of MCUs provide the power of the C28x core and Control Law Accelerator (CLA) coupled with highly-integrated control peripherals in low pin-count devices.

An internal voltage regulator allows for single-rail operation. Analog comparators with internal 6-bit references can be routed directly to control the pulse-width modulation (PWM) outputs. The ADC converts from a 0-V to 3.3-V fixed full-scale range and supports ratio-metric VREFHI/VREFLO references.

The analog front end (AFE) contains up to seven comparators with up to three integrated digital-to-analog converters (DACs): one VREFOUT-buffered DAC, up to four programmable gain amplifiers (PGAs), and up to four digital filters. The PGAs can amplify the input signal in three discrete gain modes.

The TMS320F28052F includes the FAST™ software encoder and additional motor control functions required for cascaded speed and torque loops for efficient, three-phase, field-oriented motor control (FOC).

F28052F peripheral drivers in the user code enable a sensorless InstaSPIN-FOC™ solution which can identify, tune the torque controller, and efficiently control a motor in minutes, without the use of any mechanical rotor sensors. This entire package is called InstaSPIN-FOC. The FAST estimator is called from protected ROM, while the rest of the functions required for InstaSPIN-FOC reside in user memory (FLASH and RAM). InstaSPIN-FOC has been designed for flexibility to accommodate a range of system software architectures and customization.

The main features of this device are as follows:

- High-efficiency 32-Bit CPU (TMS320C28x)
- Three 32-Bit CPU timers
- Independent 16-bit timer in each ePWM module
- Serial port peripherals
 - Three serial communications interface (SCI)
 - Dual-zone security module (universal asynchronous receiver/transmitter (UART)) modules
 - One serial peripheral interface (SPI) module
 - One inter-integrated-circuit (I²C) bus
 - One enhanced controller area network (eCAN) bus
- Analog peripherals
 - One 12-bit ADC
 - One on-chip temperature sensor for oscillator compensation
 - Up to seven comparators with up to three integrated DACs
 - One buffered reference DAC
 - Up to four PGAs
 - Up to four digital filters

2.2.6 UCC27712-Q1

The UCC27712-Q1 is a 620-V high-side and low-side gate driver with 1.8-A source, 2.8-A sink current, which is targeted to drive power MOSFETs or IGBTs. The UCC27712-Q1 includes protection features where the outputs are held low when the inputs are left open or when the minimum input pulse width specification is not met. Interlock and dead time functions prevent both outputs from being turned on simultaneously. In addition, the device accepts a wide bias supply range from 10 V to 22 V and offers UVLO protection for both the VDD and HB bias supply. The device features a robust drive with excellent noise and transient immunity including large negative voltage tolerance on its inputs, high dV/dt tolerance, wide negative transient safe operating area (NTSOA) on the switch node (HS), and interlock. The device consists of one ground-referenced channel (LO) and one floating channel (HO), which is designed for operating with bootstrap or isolated power supplies. The device features fast propagation delays and excellent delay matching between both channels. On the UCC27712-Q1, each channel is controlled by its respective input pins, HI and LI.

The main features of this device are as follows:

- High-side and low-side configuration
- Dual inputs with output interlock and 150-ns dead time
- Fully operational up to 620 V, 700-V absolute maximum on HB pin
- 10-V to 20-V VDD recommended range
- Peak output current 2.8-A sink, 1.8-A source
- dV/dt immunity of 50 V/ns
- Small propagation delay (100 ns, typical)
- Delay matching (12-ns, max)
- Low quiescent current
- UVLO protection for both channels
- All parameters specified over temperature range, -40°C to $+125^{\circ}\text{C}$

2.2.7 OPA365-Q1

The OPA365-Q1 zero-crossover, rail-to-rail, high-performance, CMOS operational amplifier is optimized for very-low-voltage, single-supply applications. Rail-to-rail input and output, low noise ($4.5 \text{ nV}/\sqrt{\text{Hz}}$), and high-speed operation make this device ideal for sampling shunt voltages to detect overcurrent in a very short period of time, which can prevent damage to other components of the circuit.

The main features of this device are as follows:

- Device temperature grade 1: -40°C to 125°C ambient operating temperature range
- Gain bandwidth: 50 MHz
- Low noise: $4.5 \text{ nV}/\sqrt{\text{Hz}}$ at 100 kHz
- Slew rate: 25 V/ μs
- Fast settling: 0.3 μs to 0.01%
- Precision
 - Low offset: 100 μV
 - Low input bias current: 0.2 pA

- 2.2-V to 5.5-V operation

2.2.8 TLV314-Q1

The TLV314-Q1 represents a new generation of low-power, operational amplifier. Rail-to-rail input and output swings (RRIO) and low quiescent current (150 μ A typically at 5 V) combine with a wide bandwidth of 3 MHz to make this device very attractive for a variety of battery-powered applications that require a good balance between cost and performance. The TLV314-Q1 achieves a low-input bias current of 1 pA.

The TLV314-Q1 incorporates: high unity gain stability, RRIO, capacitive loads of up to 300 pF, an integrated radio frequency (RF) and electromagnetic interference (EMI) rejection filter, no phase reversal in overdrive conditions, and high electrostatic discharge (ESD) protection (4-kV human-body model (HBM)).

The main features of this device are as follows:

- Device temperature grade 1: -40°C to $+125^{\circ}\text{C}$ ambient operating temperature range
- Low input bias current: 1 pA (typical)
- Rail-to-rail input and output
- Gain bandwidth: 3 MHz
- Low I_Q : 250 $\mu\text{A}/\text{Ch}$ (maximum)
- Low noise: 16 $\text{nV}/\sqrt{\text{Hz}}$ at 1 kHz
- Internal RF and EMI filter

2.2.9 LMV393-Q1

The LMV393-Q1 device is a low-voltage (2.7-V to 5.5-V) comparator, which operates from 5 V to 30 V.

The LMV393-Q1 is the most cost-effective solution for applications where low-voltage operation, low power, space saving, and price are the primary specifications in circuit design.

The main features of this device are as follows:

- 2.7-V and 5-V performance
- Low supply current (100 μA typical)
- Input common-mode voltage range includes ground
- Low output saturation voltage: 200 mV typical
- Open-collector output for maximum flexibility

2.2.10 SN74LVC2G74-Q1

This single, positive-edge-triggered, D-type flip-flop is designed for 1.65-V to 5.5-V V_{CC} operation.

A low level at the preset (PRE) or clear (CLR) input sets or resets the outputs, regardless of the levels of the other inputs. When PRE and CLR are inactive (high), data at the data (D) input that meets the setup time requirements is transferred to the outputs on the positive-going edge of the clock pulse. Clock triggering occurs at a voltage level and is not related directly to the rise time of the clock pulse. Following the hold-time interval, data at the D input can be changed without affecting the levels at the outputs.

The main features of this device are as follows:

- Supports 5-V V_{CC} operation
- Inputs accept voltages to 5.5 V
- Low power consumption, 10-mA max I_{CC}

- ± 24 -mA output drive at 3.3 V
- Typical V_{OLP} (output ground bounce) < 0.8 V at $V_{CC} = 3.3$ V, $T_A = 25^\circ\text{C}$
- Typical V_{OHV} (output V_{OH} undershoot) > 2 V at $V_{CC} = 3.3$ V, $T_A = 25^\circ\text{C}$
- I_{OFF} supports partial-power-down mode operation
- Latch-up performance exceeds 100 mA per JESD 78, Class II

2.2.11 SN74LVC541A-Q1

The SN74LVC541A octal buffer/driver is designed for 2.7-V to 3.6-V V_{CC} operation. The device is ideal for driving bus lines. This device features inputs and outputs on opposite sides of the package to facilitate printed-circuit board (PCB) layout. The three-state control gate is a two-input AND gate with active-low inputs so that if either output enable input is high (OE1 or OE2), all eight outputs are in the high-impedance state. Drive the inputs from either 3.3-V or 5-V devices. This feature allows the use of this device as a translator in a mixed 3.3-V or 5-V system environment. This device is fully specified for partial-power-down applications using I_{OFF} . The I_{OFF} circuitry disables the outputs, which prevents damaging current backflow through the device during power down.

The main features of this device are as follows:

- Operates from 2 V to 3.6 V
- Inputs accept voltages to 5.5 V
- Max t_{pd} of 5.1 ns at 3.3 V
- Typical V_{OLP} (output ground bounce) < 0.8 V at $V_{CC} = 3.3$ V, $T_A = 25^\circ\text{C}$
- Typical V_{OHV} (output V_{OH} undershoot) > 2 V at $V_{CC} = 3.3$ V, $T_A = 25^\circ\text{C}$
- Supports mixed-mode signal operation on all ports (5-V input and output voltage with 3.3-V V_{CC})
- I_{OFF} supports partial-power-down mode operation

2.2.12 LMT87-Q1

The LMT87-Q1 device is a precision CMOS integrated-circuit temperature sensor with an analog output voltage that is linearly and inversely to temperature. The LMT87-Q1 features make it suitable for many general temperature sensing-applications. The device can operate down to a 2.7-V supply with a 5.4- μA power consumption. Package options, which include the through-hole TO-92 package, allow the designer to mount the LMT87-Q1 on the board, off the board, to a heat sink, or on multiple unique locations in the same application. A class-AB output structure gives the LMT87-Q1 a strong output source and a sink current capability that can directly drive up to 1.1-nF capacitive loads. This quality means the device is well suited to drive an ADC sample-and-hold with its transient load requirements. The LMT87-Q1 accuracy is specified in the operating range of -50°C to 150°C . The accuracy, three-lead package options, and other features also make the LMT87-Q1 an alternative to thermistors.

The main features of this device are as follows:

- Very accurate: $\pm 0.3^\circ\text{C}$ typical
- Wide temperature range of -50°C to 150°C
- Low 5.4- μA quiescent current
- Sensor gain of -13.6 mV/ $^\circ\text{C}$
- Output is short-circuit protected

- Push-pull output with 50- μ A source current capability
- Cost-effective alternative to thermistors

2.2.13 InstaSPIN-FOC™ for PMSM

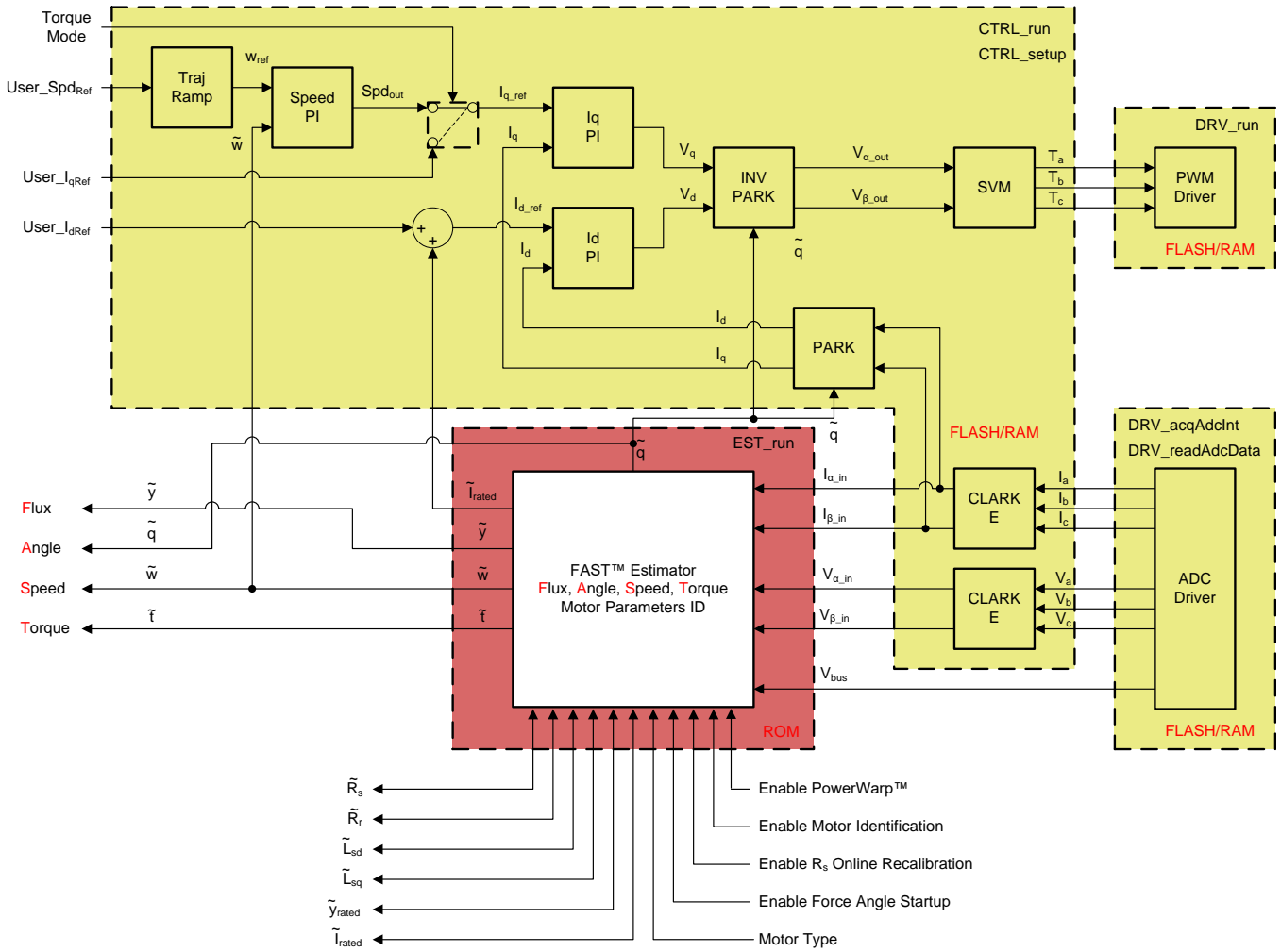
TI's InstaSPIN-FOC technology enables designers to identify, tune, and fully control any type of three-phase, variable speed, sensorless synchronous, or asynchronous motor control system. This new technology removes the requirement for a mechanical motor rotor sensor to reduce system costs and improve operation using TI's new software encoder (sensorless observer) software algorithm, FAST™ (flux, angle, speed, and torque), embedded in the read-only memory (ROM) of Piccolo devices. This ROM enables premium solutions that improve motor efficiency, performance, and reliability in all variable-speed and variable-torque applications.  shows the block diagram of the InstaSPIN-FOC.

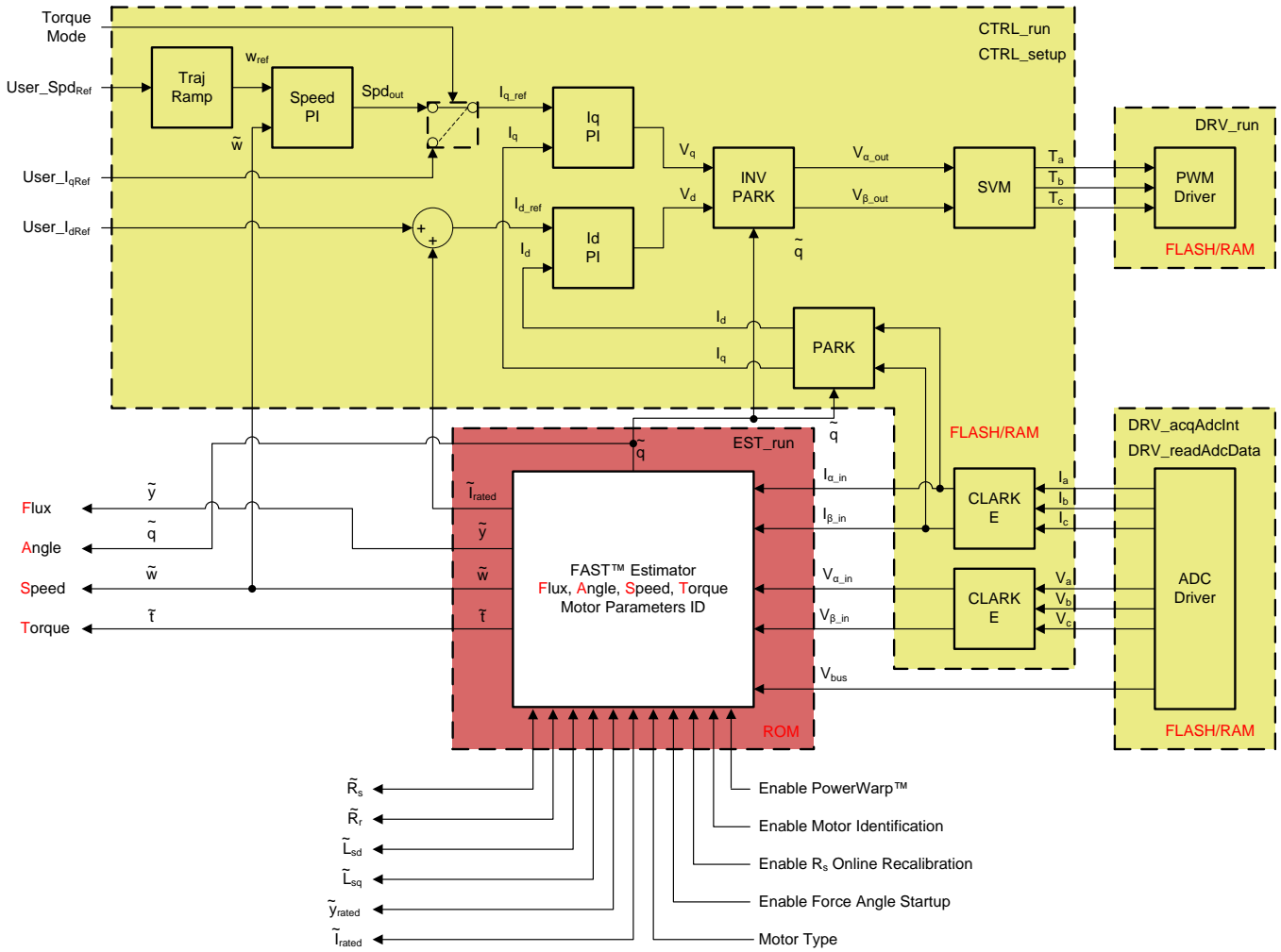

Copyright © 2017, Texas Instruments Incorporated

図 2. Block Diagram of InstaSPIN-FOC™

The main features of this device are as follows:

- Includes FAST estimator to measure rotor flux magnitude, rotor flux angle, motor shaft speed, and torque in a sensorless FOC system
- Automatic torque (current) loop tuning with option for user adjustments

- Automatic configuration of speed loop gains (K_p and K_i) provides stable operation for most applications and user adjustments required for optimum transient response
- Automatic or manual field weakening and field boosting
- Bus voltage compensation
- Automatic offset calibration ensures quality samples of feedback signals

3 System Design Theory

The primary goal of this reference design, with regards to the PCB in [Fig 3](#), is to make a compact solution that allows the option to drive three-phase BLDC motors for the AC compressor with a DC bus voltage up to 400 V. This reference design uses a minimum number of isolated parts, which are more expensive than non-isolated components. DC-link capacitors are not included in this PCB due to the small form factor. [Fig 3](#) shows that the MCU, as well as the entire digital logic, is located on the "hot" side (high-voltage side). The "cold" side delivers the supply voltage for the gate drivers as well as the MCU.



図 3. TIDA-01418 PCB—Top View ⁽¹⁾

⁽¹⁾ Uses only two isolated components: one is the digital signal isolator and the other is the isolated transformer for the power supply unit.

☒ 4 shows the bottom side of the TIDA-01418, where the current monitoring circuit is located.

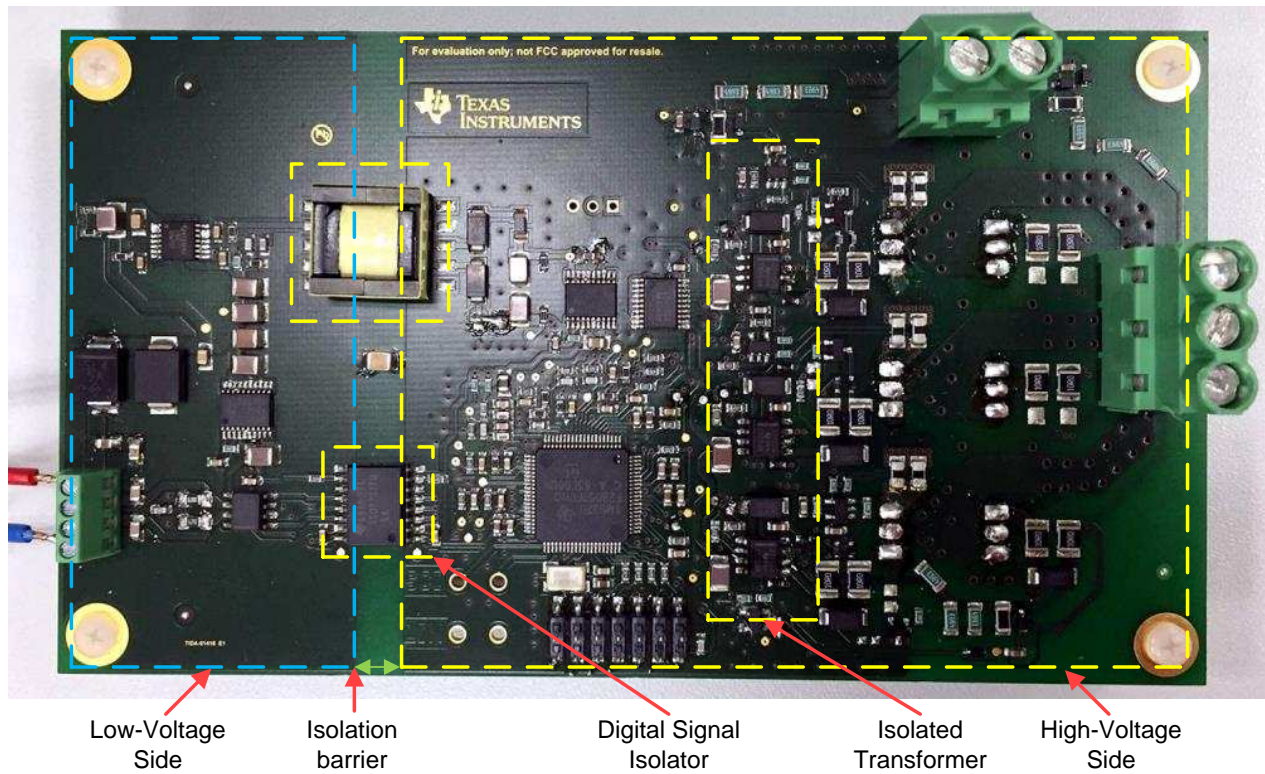
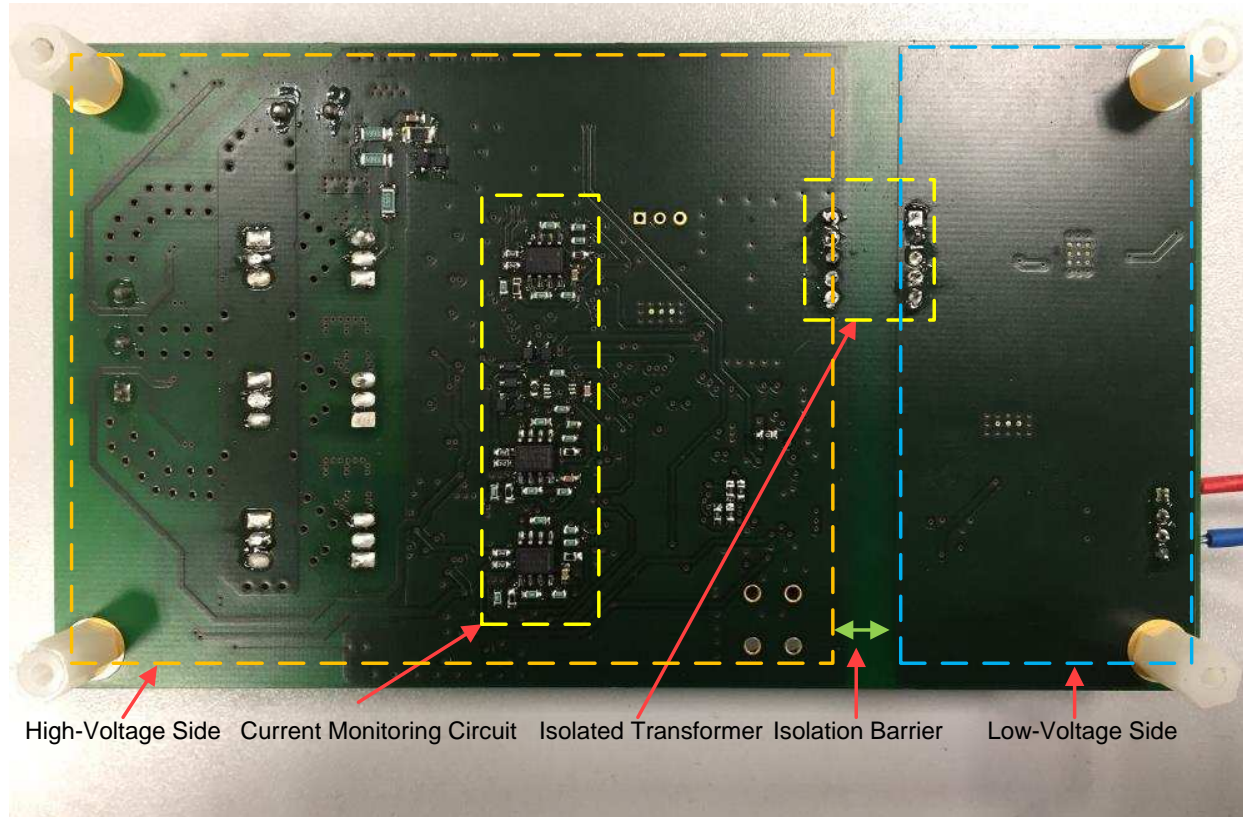

☒ 4. TIDA-01418—Bottom View ⁽²⁾

⁽²⁾ The current-monitoring circuit is located on the bottom side of the PCB. This image show the PCB with the IGBTs removed to provide a better view of the bottom side.

3.1 Protection Circuit and Power Supply

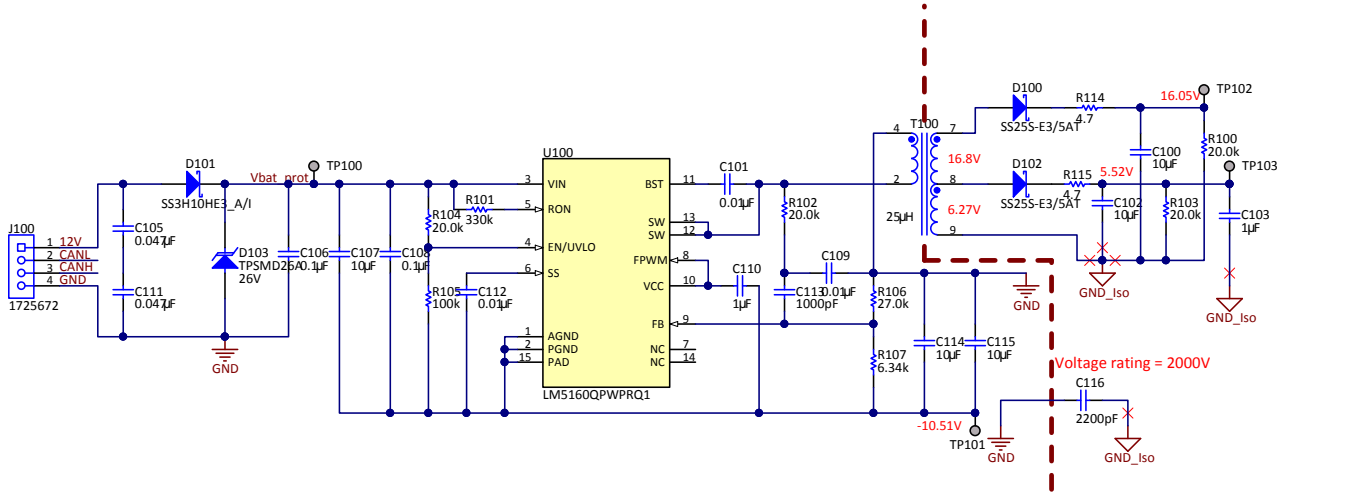
The supply voltage for the MCU, gate drivers, and the operational amplifiers (op amps), as well as all the other logic components located on the high-voltage side ("hot" side) of the PCB, travels through an isolated barrier from the low-voltage side (12-V battery). For this reason, the TIDA-01418 reference design uses an isolated power supply LM5160-Q1 in Fly-Buck-Boost topology, as  shows.



図 5. Power supply, Isolated Fly-Buck-Boost Converter

The Fly-Buck-Boost converter based on the LM5160-Q1 is implemented because it is cost-effective, easy to design, and has good flexibility. The LM5160-Q1 handles a wide input voltage (V_{IN}) range up to 65 V.

One core component of the Fly-Buck-Boost power supply, not including the controller itself, is the isolated transformer, which has one primary winding and one secondary winding with center tapping (see ). Two output voltages are present on the power rails of the transformer on the secondary side, one of which is used to supply the gate drivers (16.8 V, unipolar supply). The other output voltage is followed by the LDO, which regulates an input of 6.27 V down to 3.3 V and supplies the MCU, op amps, and all other logic components.

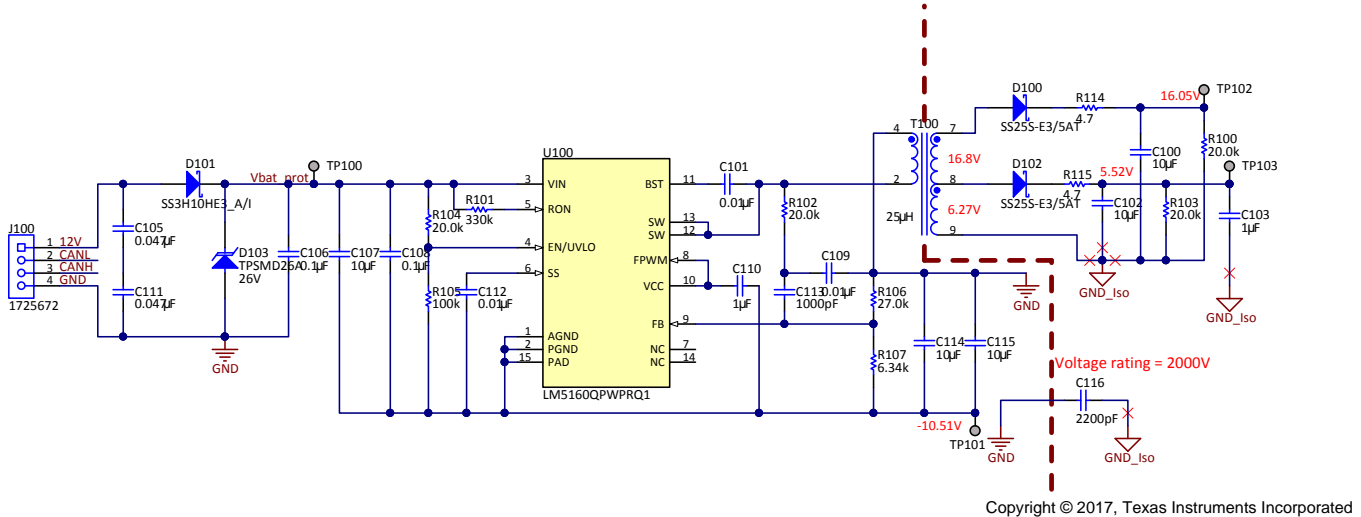
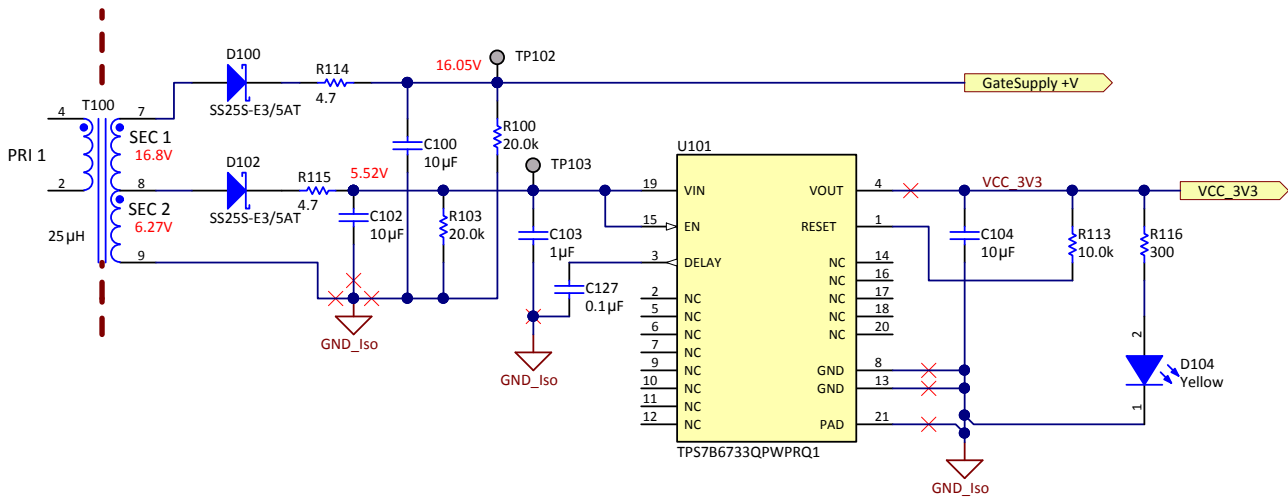

図 6. Isolated Transformer With Two Output Voltages on Secondary Side

The center-tapped transformer obtains the 16.8 V and 6.27 V and can provide better voltage balance and regulation because both rails can handle loads separately and the voltages do not collapse.

The protection circuit shown in [Figure 5](#) consists of an ESD protective part, reverse battery protection diode, transient voltage suppressor (TVS) diode, and one ceramic capacitor for better noise (ripple) filtering.

Two in-series capacitors with high-voltage rating values (100 V) are used for ESD protection. These capacitors are populated on the PCB in an L-shape (90° rotated from each other), which is a common technique in automotive applications. This way of arranging the ESD capacitors can prevent short circuit. When PCB bending occurs due to vibrations, the ceramic capacitor is subject to mechanical damage and inner layers of the capacitor are at the risk of being shorted.

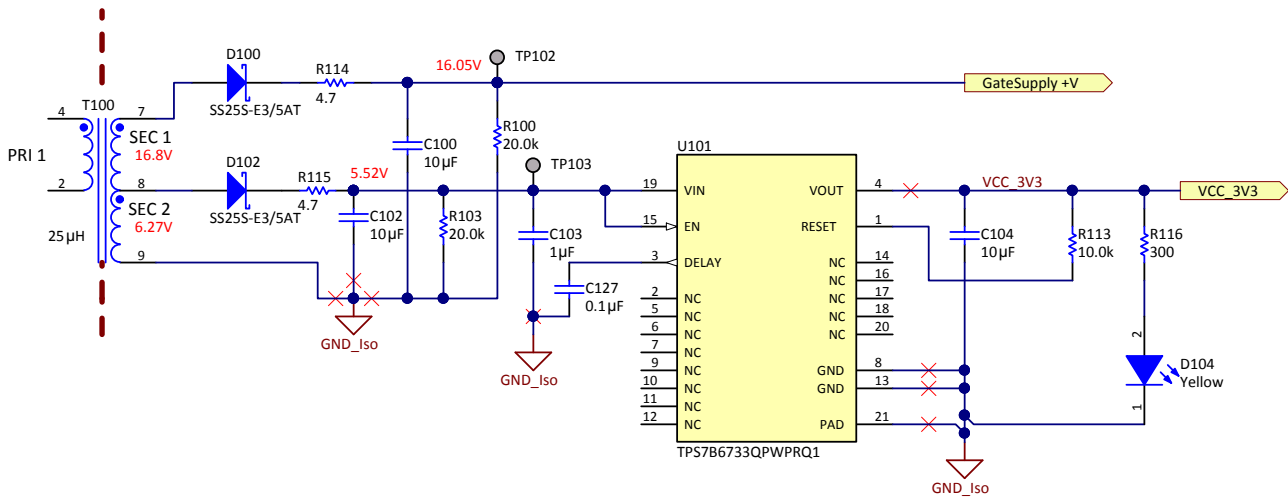
A TVS diode protects the circuit against load dump transient, which occurs in the event of disconnecting a discharged battery while the alternator is generating charging current to the other loads which remain on the alternator circuit. Another important requirement for a TVS diode is the 24-V jump start (for 12-V systems). In this design, the TVS has been chosen in such a way that the standoff voltage value of the diode is above the voltage level, which can occur at the jump start of an event. In other words, below this voltage level, which is called reverse standoff voltage, the TVS diode is transparent for the rest of the circuit.

3.2 Isolated Communication Interface

The communication interface of this reference design is based on a controller area network (CAN bus) communication, where the interface between the CAN transceiver and MCU is isolated. [Figure 7](#) shows a schematic of the complete communication part of the TIDA-01418 reference design. The MCU is located on the high-voltage side of the PCB and the CAN transceiver is located on the low-voltage side; so, the only way to establish the interface connection between them is to use the digital signal isolator. An LDO with fixed output voltage (TPS7B6750-Q1) supplies the TCAN1042-Q1 transceiver as well as the primary side of the digital signal isolator (ISO7731-Q1) with 5 V. The input voltage of the LDO is also protected against reverse battery, ESD, and load dump transient.

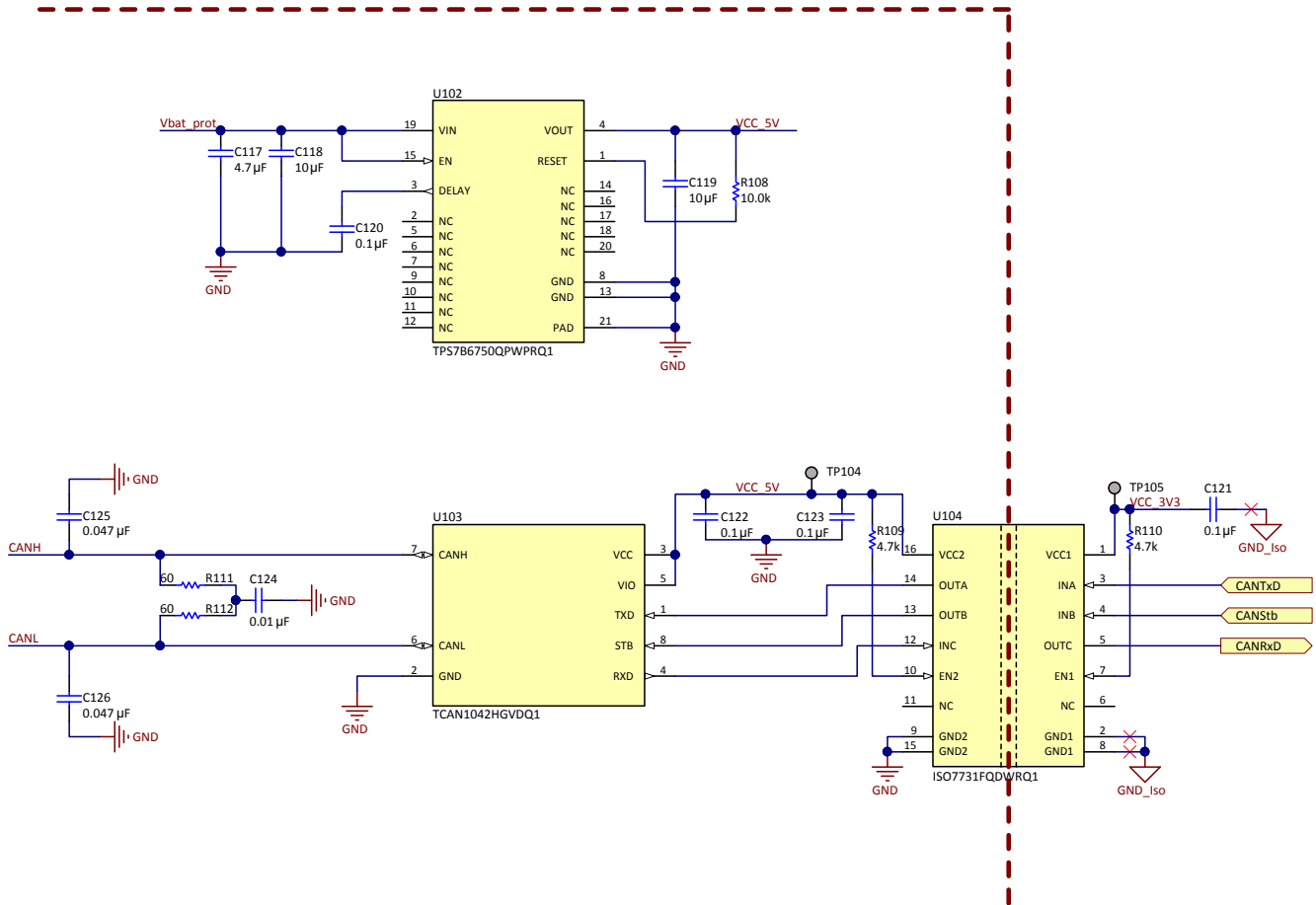

Copyright © 2017, Texas Instruments Incorporated

図 7. Isolated CAN Transceiver With 5-V Power Supply Delivered by LDO (Barrier is Dashed Line)

The triple-channel digital isolator ISO7731-Q1 incorporates reinforced insulation with very-low propagation delay (11 ns typically) as well as high electromagnetic immunity and low emissions at low power consumption.

ISO7731-Q1 uses an ON-OFF keying (OOK) modulation scheme to transmit the digital data across an isolation barrier. 図 8 shows the functional block diagram, which shows the transmitter and receiver part isolated by an SiO₂-based capacitive-isolation barrier. The transmitter sends a high-frequency carrier across the barrier to represent one digital state and sends no signal, which represents the other digital state. On the receiver side, the signal is demodulated and a buffer stage generates the output.

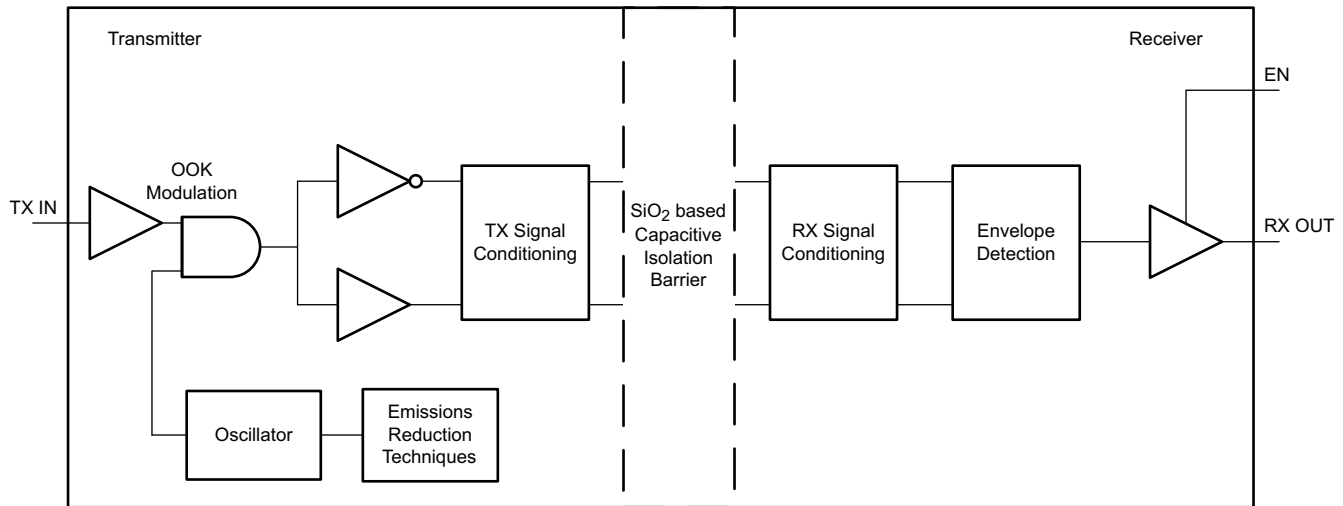

Copyright © 2016, Texas Instruments Incorporated

図 8. ISO7731-Q1 Functional Block Diagram

3.2.1 IGBT Gate Driver

This reference design uses non-isolated high- and low-side gate drivers with interlock (UCC27712-Q1), which are capable of 1.8-A/2.8-A source and sink peak current. According to the data sheet, the supply voltage for the gate drivers must be in the range of 10 V to 20 V. In this design, the UCC27712-Q1 drivers are supplied with 16 V.

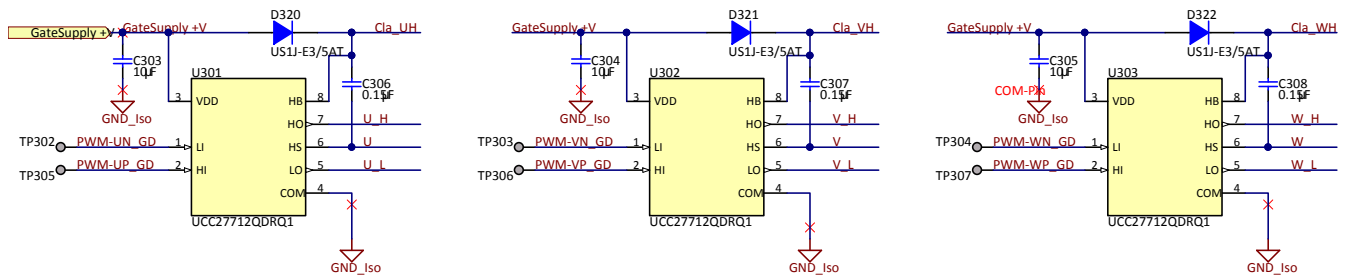

Copyright © 2017, Texas Instruments Incorporated

図 9. UCC27712-Q1 High- and Low-Side Gate Drivers

In bridge topologies like half-bridge or full-bridge, the source and emitter pin of the top-side power IGBT switch is referenced to a node whose voltage changes dynamically; that is, not referenced to a fixed potential, so floating-driver devices are necessary in these topologies. As 図 10 shows, the UCC27712-Q1 consists of one ground-referenced channel (LO) and one floating channel (HO), which is designed for operating with bootstrap or isolated power supplies and can handle up to 600 V. The driver can be used with 100% duty cycle as long as HB-HS can reach a value above the UVLO of the high side. The device features fast propagation delays and excellent delay matching between both channels. On the UCC27712-Q1, each channel is controlled by its respective input pins. The device features robust drive with large negative voltage tolerance on its inputs, high dV/dt tolerance, and wide negative transient safe operating area (NTSOA) on the switch node (HS).



図 10. UCC27712-Q1 Functional Block Diagram

The UCC27712-Q1 includes protection features where the outputs are held low when the inputs are floating or when the minimum input-pulse-width specification has not been met. Interlock and dead-time functions prevent both outputs from being turned on simultaneously. The device offers UVLO protection for both the VDD and HB bias supply.

3.3 IGBT Inverter

図 11 shows that the IGBT-based three-phase inverter consists of three half-bridges, where each half bridge is controlled by one UCC27712-Q1 driver. This reference design chooses the asymmetrical gate drive for the IGBTs, where the turnoff time is shorter than the turnon time. The series-connected fast-recovery diode is used to keep the gate resistance during turnoff lower than the gate resistance during turnon. This task is necessary because the turnoff delay time is often longer than the turnon delay time for some of the power devices. This safeguard is also helpful in preventing a parasitic turnon through the Miller capacitance. Alternatively, if the value chosen for the resistor in-series with the fast-recovery diode is too low, this action can lead to large voltage overshoot across the power devices, which results from di/dt being too high during turnoff. This relationship will always be a trade-off between switching speed and robustness. As a general rule, assume that $R_{ON} = 2 \times R_{OFF}$.

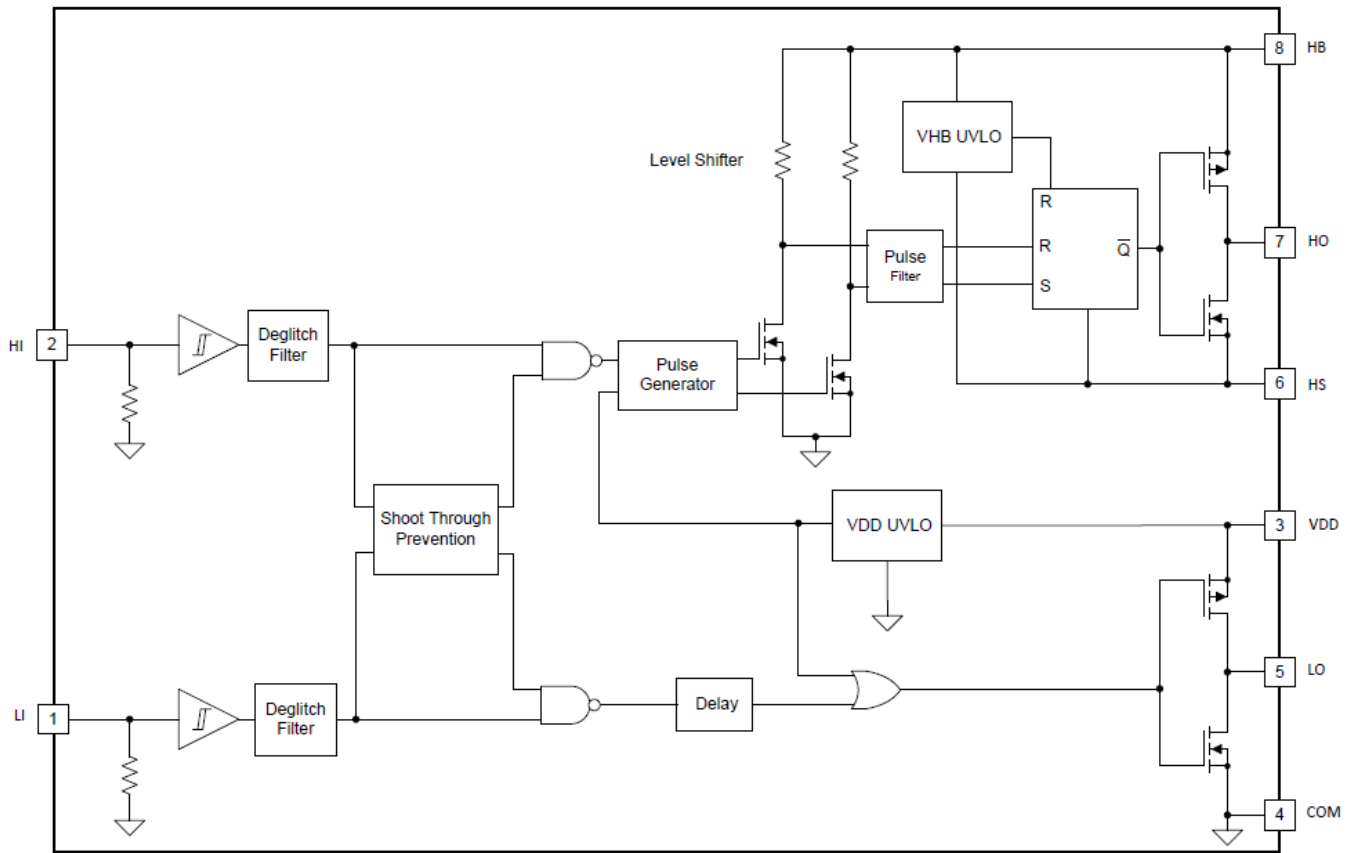
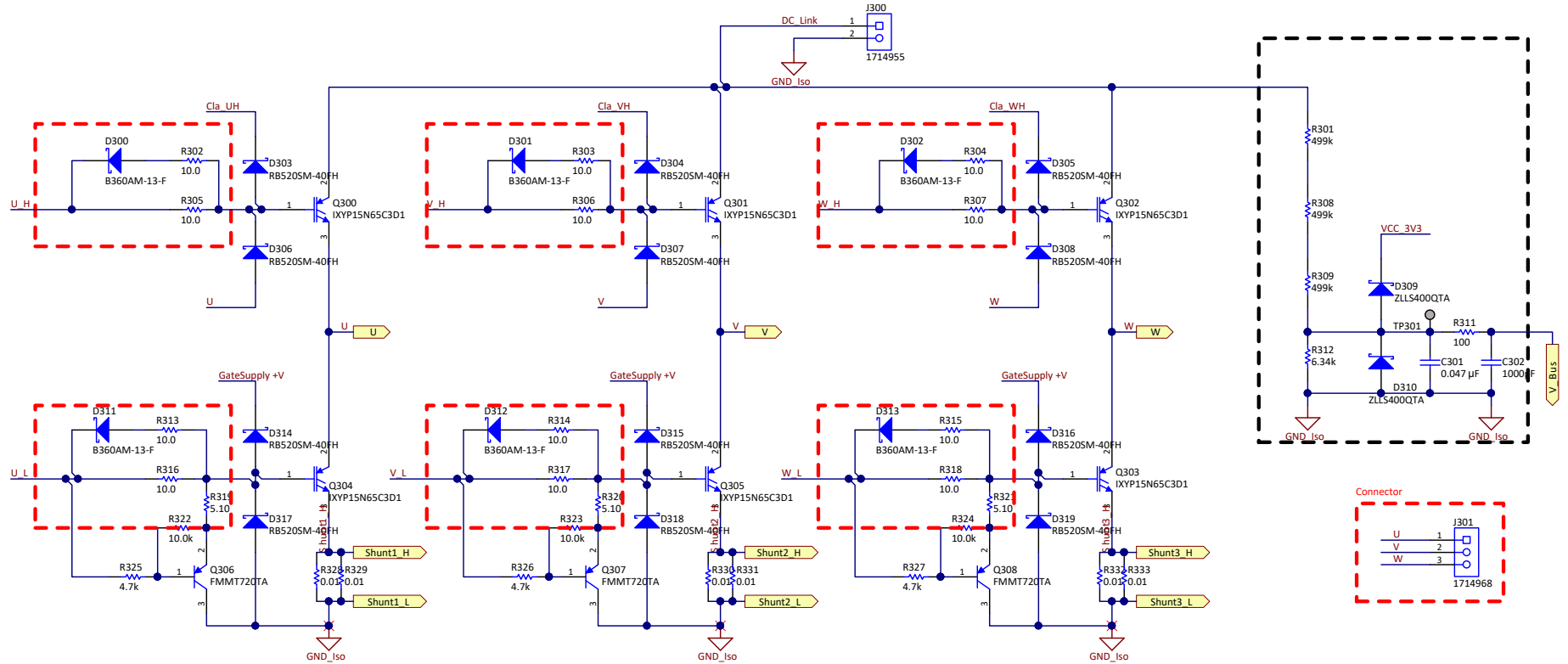

Copyright © 2017, Texas Instruments Incorporated

図 11. Three-Phase Inverter With Voltage Divider (Right Side) and Clamping Diodes to Measure Bus Voltage

The unipolar gate drivers control the IGBTs, which means that the IGBT gates must not encounter any negative voltage when switching them off. One possible risk is that the collector transient voltage can be coupled to the gate of the IGBT through the parasitic Miller capacitance, which leads to a false turnon of the IGBT. Resolve this issue by using an active Miller clamp circuit (see 図 12). The Miller clamp provides a low impedance path to ground. The Miller clamp activates when the low-side IGBT is turned off. A Miller clamp circuit allows the use of a unipolar gate drive supply instead of a bipolar gate drive supply, which simplifies the power supply design for a more optimal solution at a reduced cost and smaller board size.

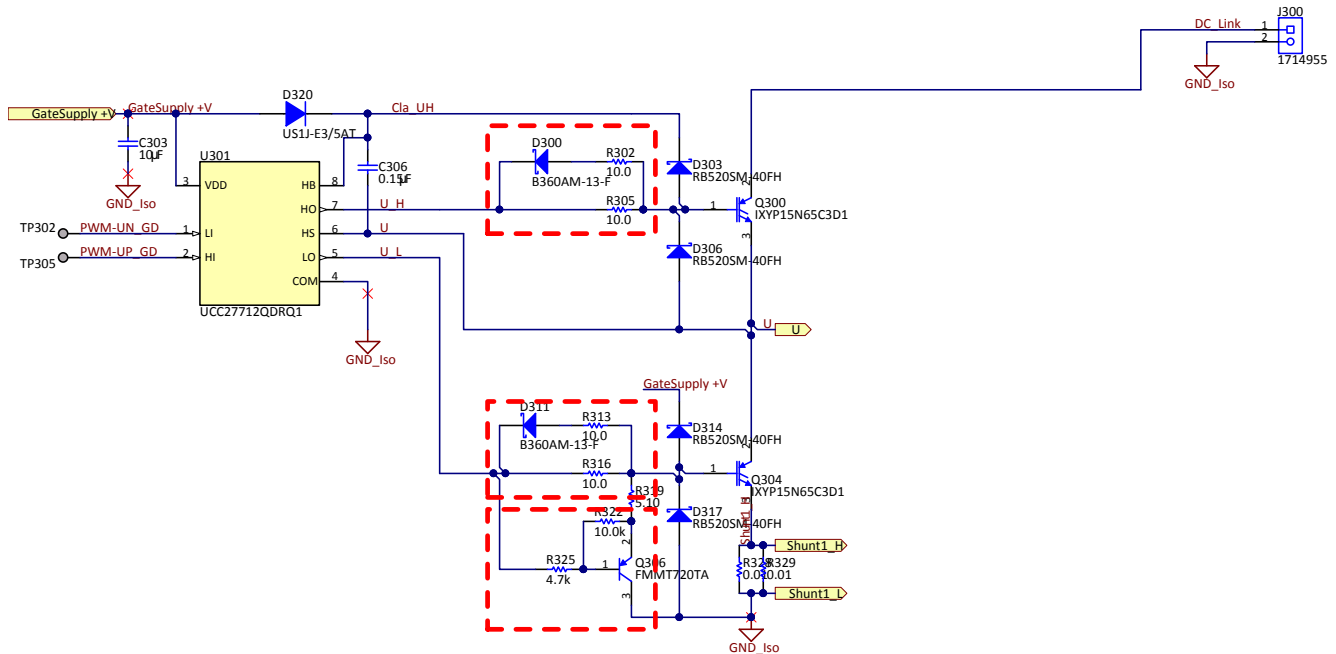

Copyright © 2017, Texas Instruments Incorporated

図 12. UCC27712-Q1 With High- and Low-Side IGBTs ⁽³⁾

⁽³⁾ The low-side IGBT has an active Miller clamp circuit. All IGBTs are asymmetrical gate drives, for which the turnoff time is shorter than the turnon time.

3.4 Current Monitoring

This reference design accomplishes overcurrent and short-circuit current protections by using the current monitor circuit shown in 図 13. This circuit consists of one differential op amp, one op amp as a voltage follower generating reference voltage, two comparators, and one D-type flip-flop.

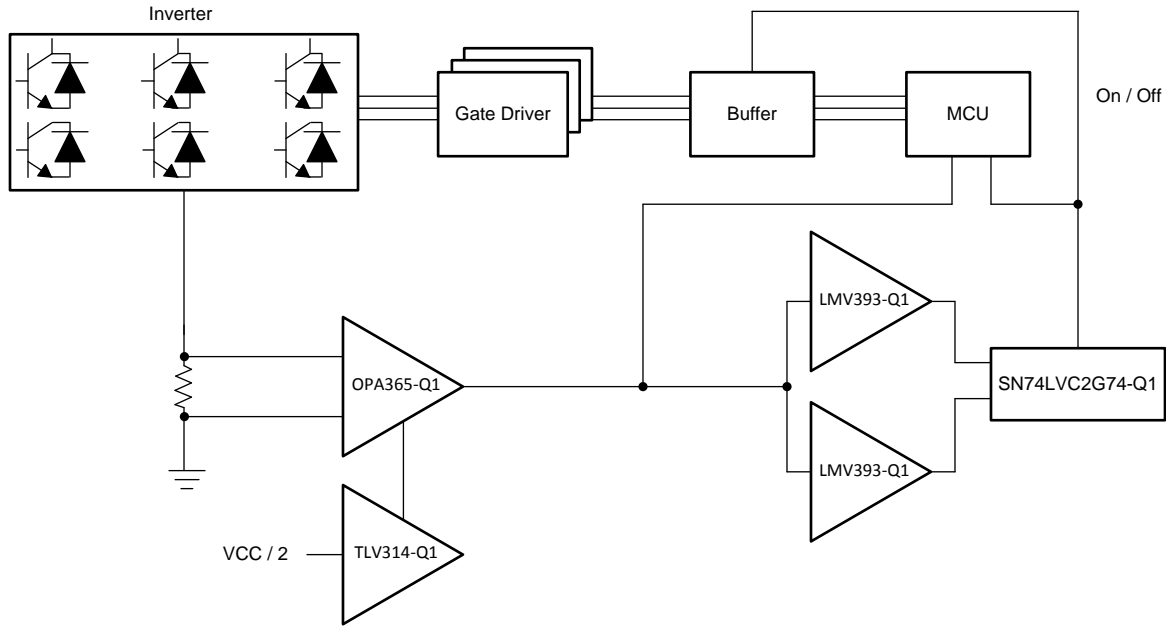

Copyright © 2017, Texas Instruments Incorporated

図 13. Block Diagram of Shunt Current-Monitoring Circuit

The op amp performs the differential voltage measurement across the shunt resistor. The voltage across the shunt resistor corresponds to the current that flows through the inverter. The requirements for the differential op amp in this application, while detecting overcurrent or short-circuit current, are: low noise, fast settling, low offset, and a slew rate, which has to be big enough to achieve the fast response time (typically a couple of μs) for the whole system. This reference design uses the OPA365-Q1 (see 図 14) as a differential op amp, which delivers excellent performance and meets all the previously-mentioned requirements (4.5 $\text{nV}/\sqrt{\text{Hz}}$ at 100 kHz, 0.3 μs to 0.01% settling time, 100- μV offset, 25-V/ μs slew rate). The TLV314-Q1 connected as a voltage follower functions as a source for the reference voltage. The level of the reference voltage, which TLV314-Q1 delivers to the differential op amps, is $V_{CC} / 2$ (1.65 V). The output voltage range for the differential op amps (OPA365-Q1) varies from 1.65 V to 3.3 V for one direction of shunt current and from 1.65 V down to 0 V for the other direction of shunt current.

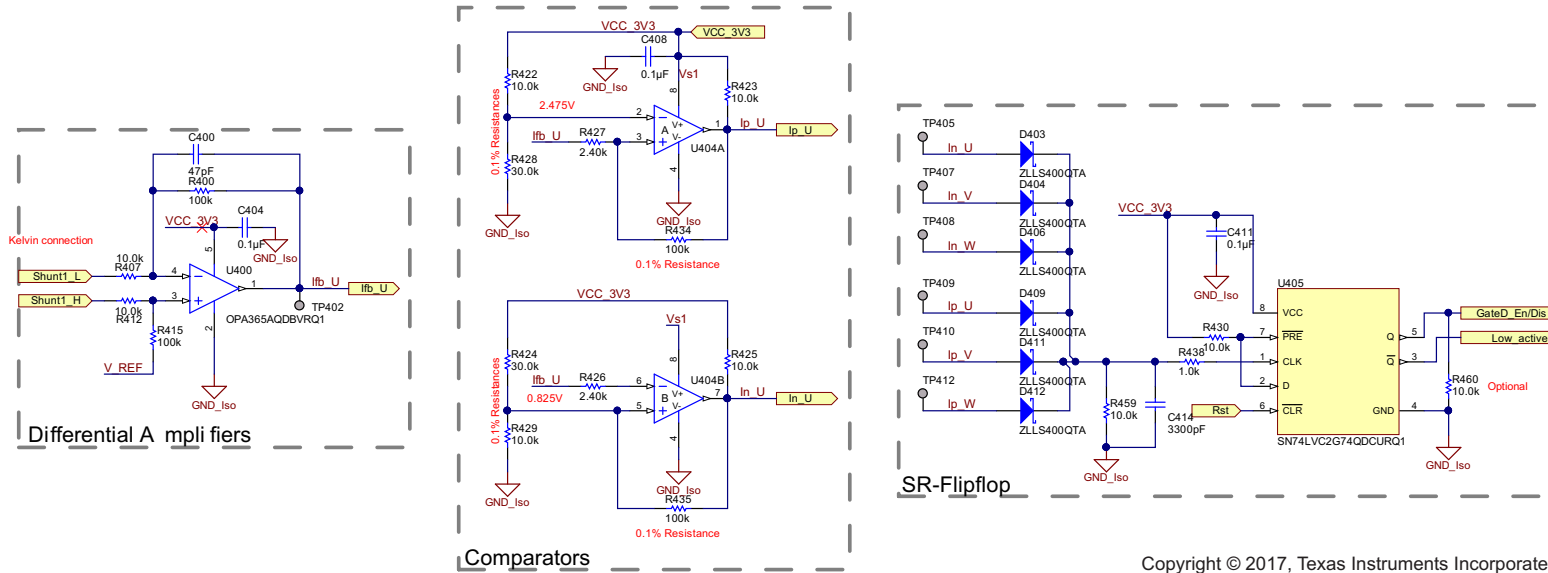

Copyright © 2017, Texas Instruments Incorporated

図 14. Overcurrent Protection Circuit

Monitoring the OPA365-Q1 output with an ADC from the MCU is not sufficient for detecting the short-circuit current and overcurrent in the inverter as fast as possible. For this reason, each differential op amp is followed by two comparators, one of which is always inverted. The comparators set the trigger levels, which are defined so that they correspond to the overcurrent. The inverted comparator makes it possible to detect current peaks in the shunt resistor in the opposite direction as well. When the overcurrent or short-circuit current occurs on one of the phases of the inverter, the responsible comparator detects it and changes its output state accordingly (which is connected to the flip-flop), the flip-flop latches its output, and disables the octal buffer between the MCU and gate drivers (see 図 14). 図 15 shows the SN74LVC541-Q1 octal buffer with tri-state outputs. As soon as the buffer is to be disabled from the flip-flop output signal ("GateD_En/Dis"), the gate driver input signals are pulled down through the low-side resistors connected to each control line (on the right side), and thus the gate drivers force the IGBTs to turn off.



図 15. SN74LVC541-Q1 Octal Buffer With Tri-State Outputs Connected Between MCU and Gate Drivers

3.5 Motor Voltage Feedback Circuit

Figure 16 shows the voltage divider circuit, which is used to measure the back-electromotive force (back-EMF) of the unenergized winding. Back-EMF feedback is required for sensorless control to estimate the position of the rotor for accurate commutation. The voltage feedback circuit output is followed by clamping diodes to provide additional protection to the ADC pins of the MCU.

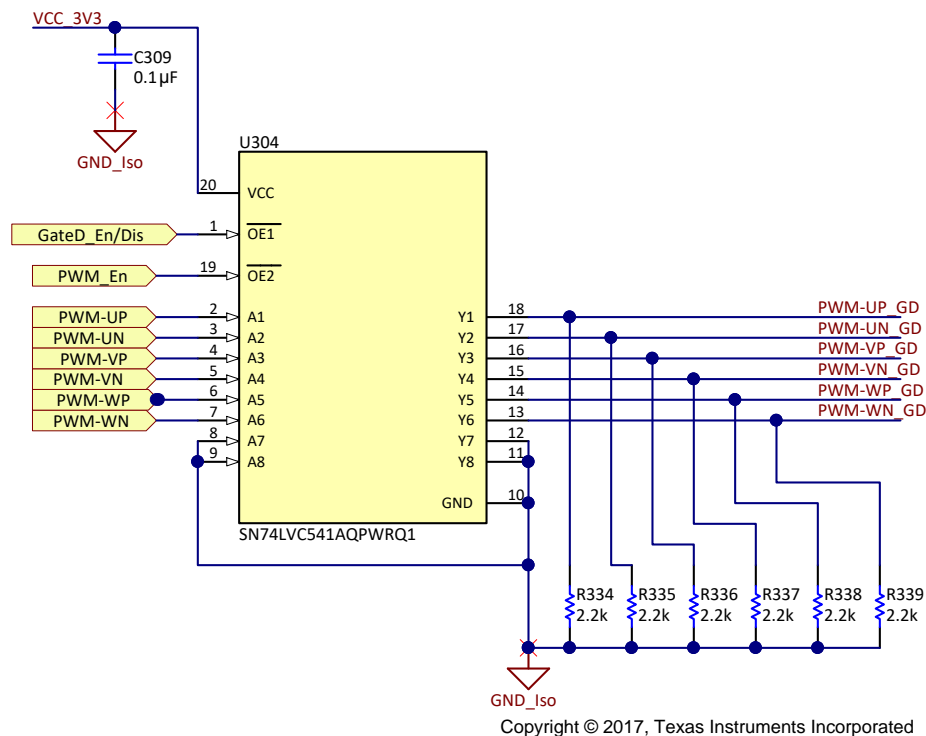
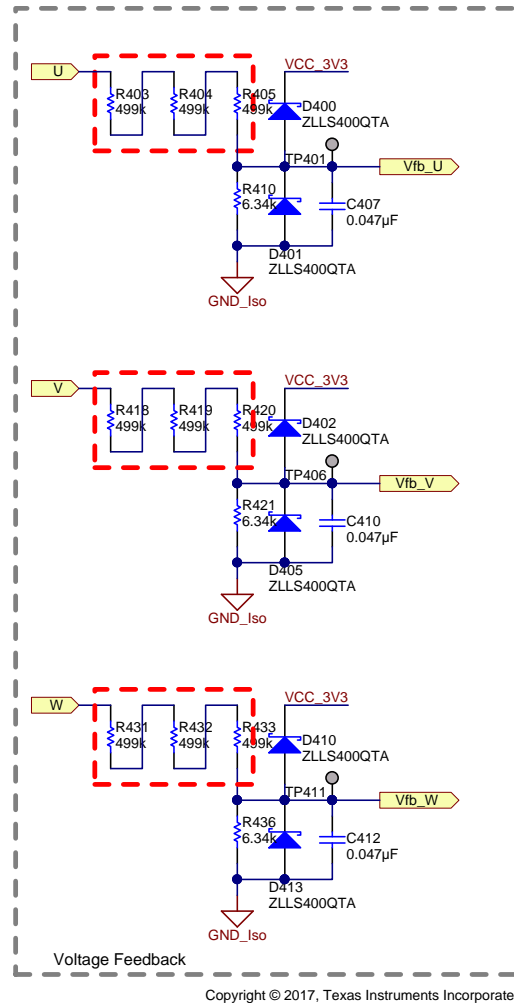

Figure 16. Motor Voltage Feedback Circuit

3.6 Microcontroller

The MCU selected for this reference design (TMS320F28052F) measures the phase voltage and current signals of the motor and generates the appropriate control signal for the power stage. The motor drive controller uses InstaSPIN-FOC, a sensorless field-oriented control algorithm for BLDC motors. Field-oriented control allows for optimal efficiency and noise performance from the motor being driven by the controller. InstaSPIN-FOC uses the signals from the motor back-EMF (voltage of each motor phase) and phase currents (each motor phase) to interpolate where the motor rotor is located and send the correct drive patterns.

4 Getting Started Hardware and Software

4.1 Hardware

This reference design allows control of three-phase, high-voltage BLDC motors with high power output. Testing for this design uses the following pictured test equipment. [Figure 17](#) shows the power analyzer and the high-voltage power supply, which supplies the TIDA-01418 reference design with 400 V. The power analyzer is used to monitor and analyze the efficiency of the inverter. The dynamometer controller (see [Figure 19](#)) controls the motor load and also measures the rotations per minute (RPM) of the running motor.

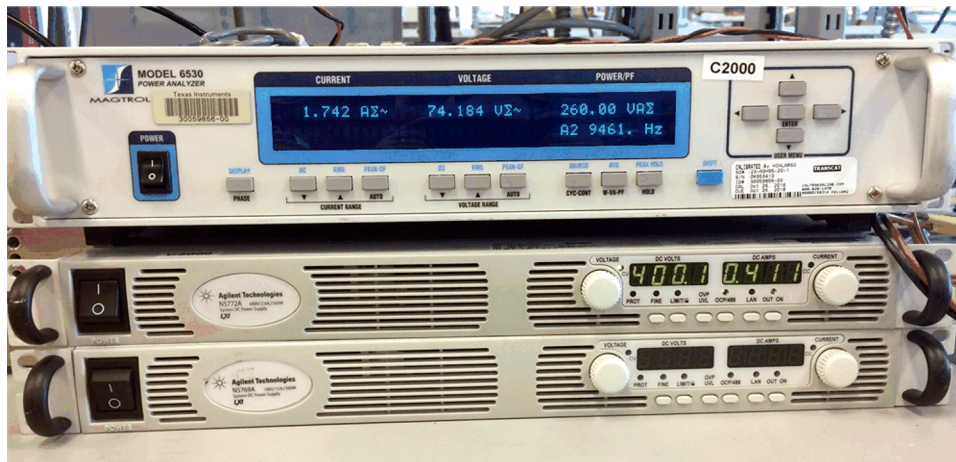

Figure 17. High-Voltage Power Supply (Agilent NS772A) and Power Analyzer (Magtrol 6530)

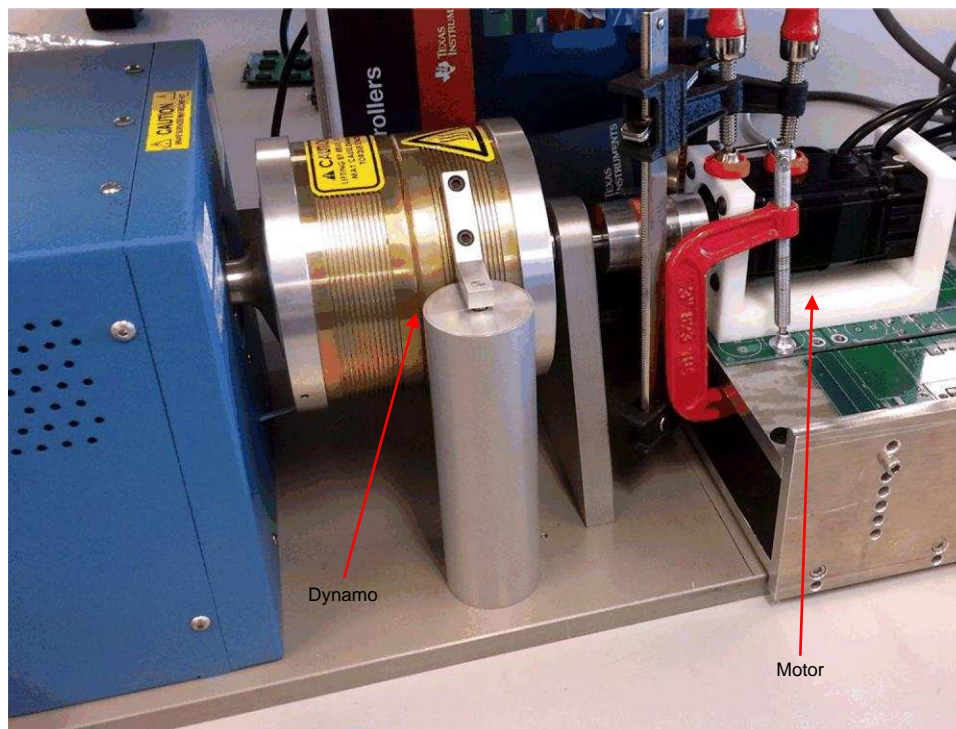
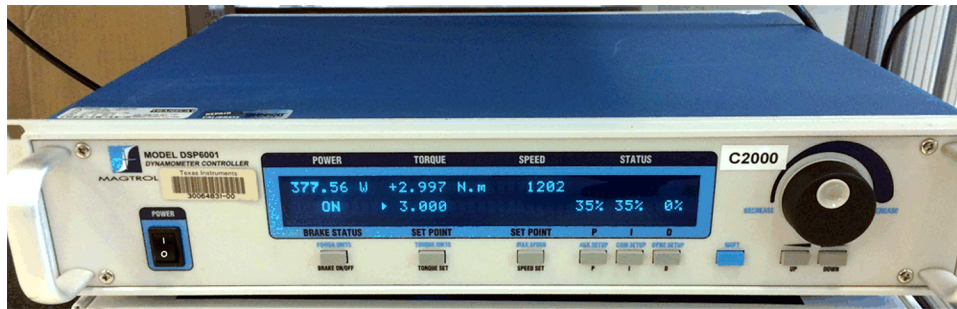
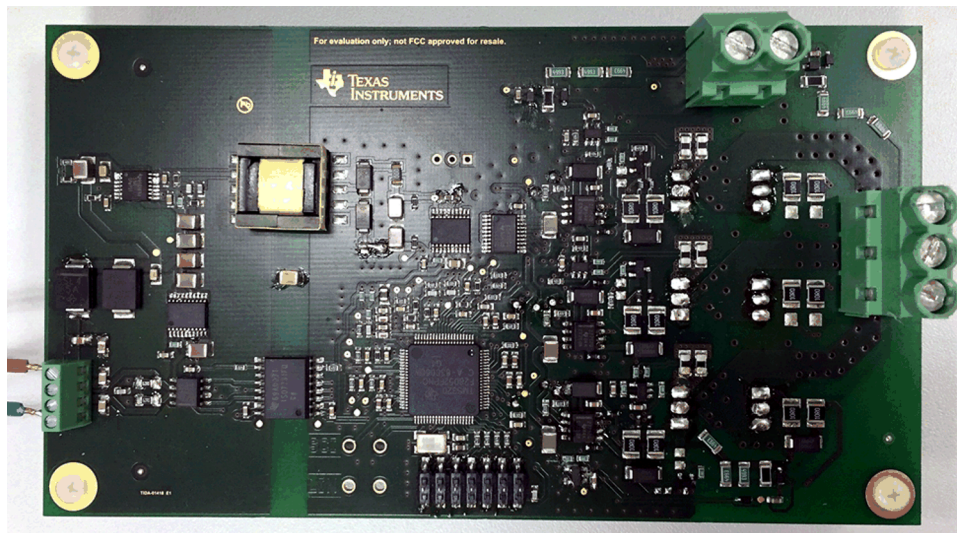

Figure 18. Three-Phase BLDC Motor and Dynamometer (Magtrol)



☒ 19. Dynamometer Controller



☒ 20. TIDA-01418 Test PCB Image

4.2 Software

4.2.1 Download and Install CCS™ Software and MotorWare™ Software

This reference design uses MotorWare™ Software for the BLDC motor control and system controllers. To get started, download the latest version from [TI.com](http://www.ti.com).

See the resource for TI's Code Composer Studio™ (CCS) software at: <http://www.ti.com/tool/ccstudio> for information on downloading the integrated development environment for the C2000 code.

Download the MotorWare software from Texas Instruments at: <http://www.ti.com/tool/MOTORWARE>.

5 Testing and Results

Figure 21 shows the test setup of the TIDA-01418 reference design.

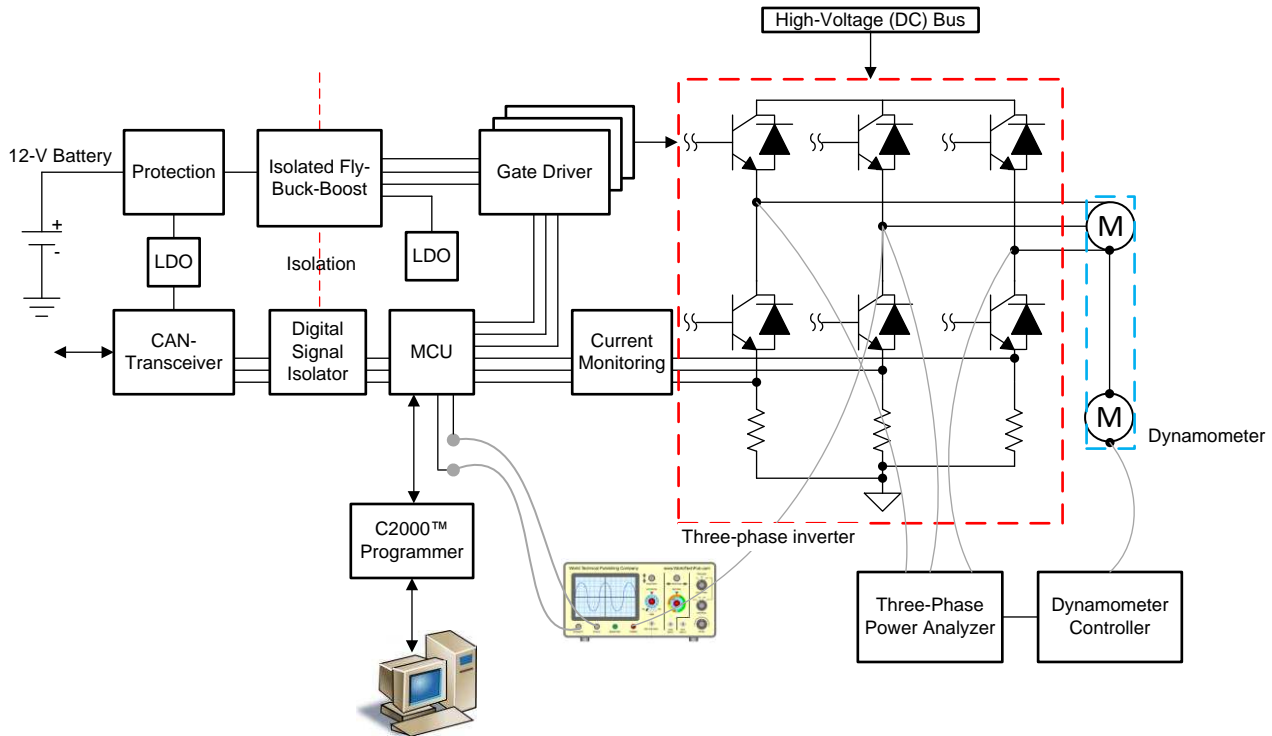

Copyright © 2017, Texas Instruments Incorporated

Figure 21. TIDA-01418 Test Setup

Several tests were conducted to verify the performance of the motor driver board:

- Loaded board
- Motor spins down to 100 RPM
- Overcurrent protection

Figure 22 shows an oscilloscope image of the running motor with a light load, where channel 4 represents the current in one phase of an inverter, channel 2 shows the angle of the rotor (as estimated by the MCU), and channel 1 represents motor phase voltage.

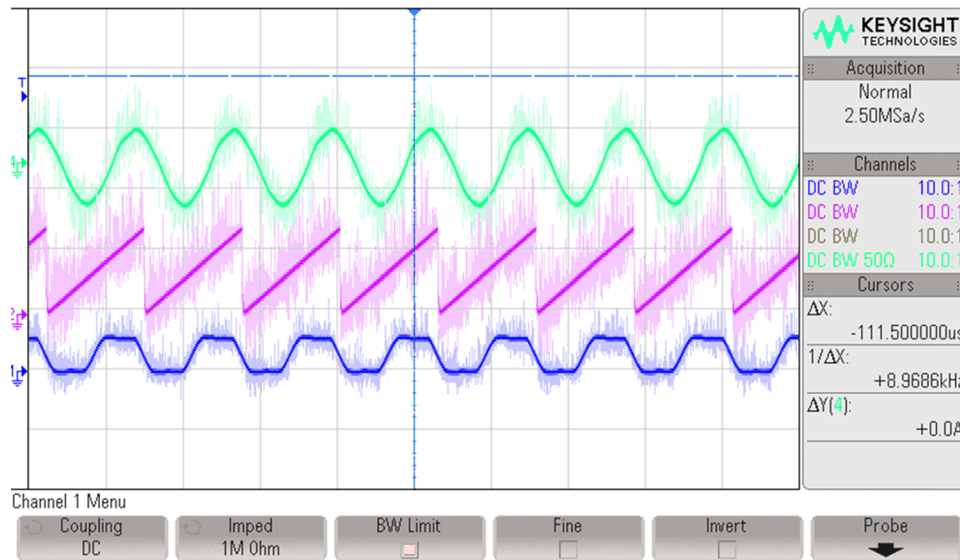

Figure 22. Ch2: MCU Simulated Angle of Rotor for Open-Loop Control; CH4: Motor Current (One Phase)

Figure 23 shows an oscilloscope image that corresponds to the 100 RPM of the light-loaded motor, where channel 4 represents the motor current and channel 1 shows the rotor angle.

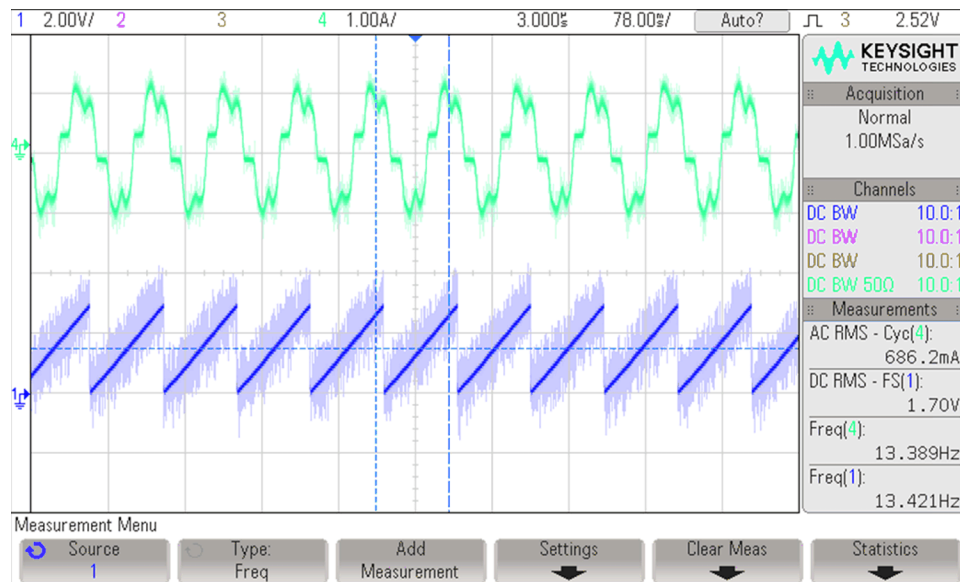
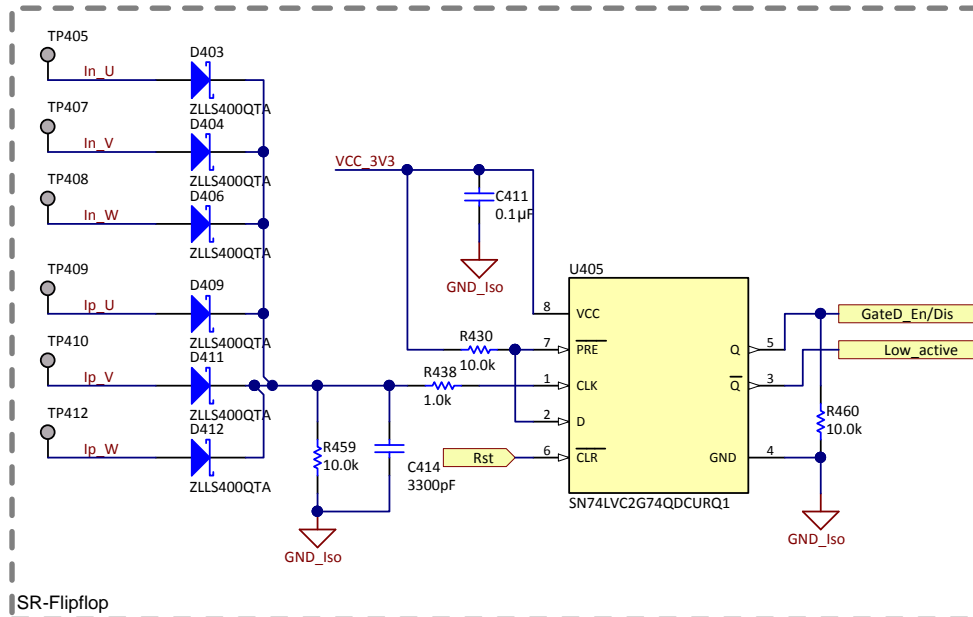

Figure 23. Motor Spinning With 100 RPM

Figure 25 shows the overcurrent condition, where channel 3 represents the waveform at the input of the SR-flip-flop (pin 1 in Figure 24). This trigger signal originates from one of the comparators, which is triggered (output HI) after the shunt current amplifier output reaches the voltage threshold. The voltage threshold corresponds to the preset high-current value.



Copyright © 2017, Texas Instruments Incorporated

Figure 24. SR-Flipflop

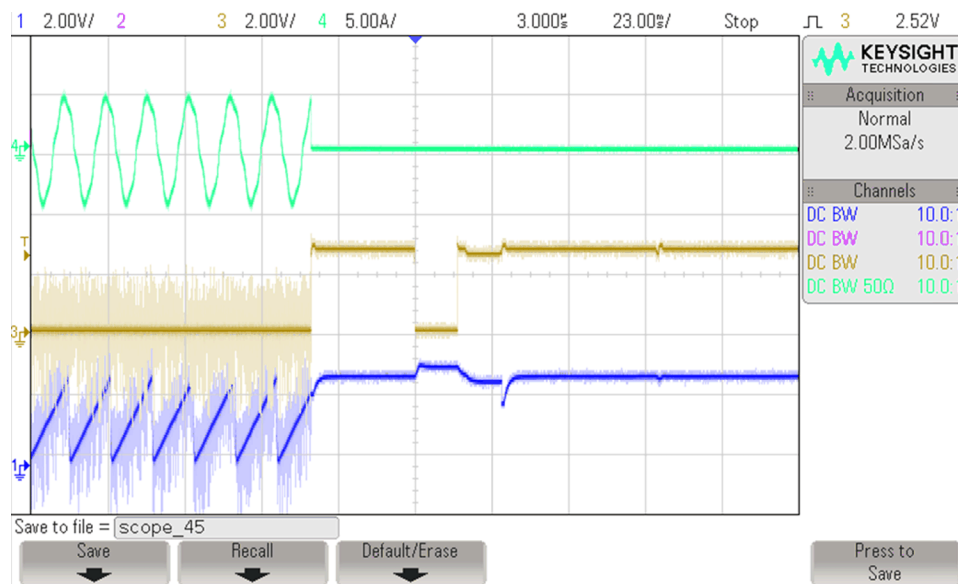

Figure 25. Overcurrent Condition

Since one of the goals for this TI-design was small PCB-size, the using of high voltage capacitors for each half bridge was avoided. Therefore the noise on the signal traces in Figure 22 and Figure 23 is visible.

To reduce the noise level significantly or eliminate it, it is strongly recommended to use high voltage foil capacitor for each half bridge as well as DC-Link capacitors on the high voltage DC bus connector.

6 Design Files

6.1 Schematics

To download the schematics, see the design files at [TIDA-01418](#).

6.2 Bill of Materials

To download the bill of materials (BOM), see the design files at [TIDA-01418](#).

6.3 PCB Layout Recommendations

6.3.1 Layout Prints

To download the layer plots, see the design files at [TIDA-01418](#).

6.4 Altium Project

To download the Altium project files, see the design files at [TIDA-01418](#).

6.5 Gerber Files

To download the Gerber files, see the design files at [TIDA-01418](#).

6.6 Assembly Drawings

To download the assembly drawings, see the design files at [TIDA-01418](#).

6.7 商標

InstaSPIN, Piccolo, E2E, C2000, Fly-Buck, FAST, InstaSPIN-FOC, MotorWare, Code Composer Studio are trademarks of Texas Instruments.

すべての商標および登録商標はそれぞれの所有者に帰属します。

7 Software Files

To download the software files, see the design files at [TIDA-01418](#).

8 About Author

LEVAN BIDZISHVILI is a systems engineer at Texas Instruments where he is responsible for developing reference design solutions for the automotive body and HVAC segment. Levan brings his extensive experience of more than 7 years of automotive analog and digital applications to this role. Levan earned his master's degree of engineering in sensor systems technology from the University of Applied Sciences in Karlsruhe, Germany.

改訂履歴

資料番号末尾の英字は改訂を表しています。その改訂履歴は英語版に準じています。

	Page
2018年1月発行のものから更新	
• Updated incorrect part number	24

TIの設計情報およびリソースに関する重要な注意事項

Texas Instruments Incorporated ("TI")の技術、アプリケーションその他設計に関する助言、サービスまたは情報は、TI製品を組み込んだアプリケーションを開発する設計者に役立つことを目的として提供するものです。これにはリファレンス設計や、評価モジュールに関係する資料が含まれますが、これらに限られません。以下、これらを総称して「TIリソース」と呼びます。いかなる方法であっても、TIリソースのいずれかをダウンロード、アクセス、または使用した場合、お客様(個人、または会社を代表している場合にはお客様の会社)は、これらのリソースをここに記載された目的にのみ使用し、この注意事項の条項に従うことに合意したものとします。

TIによるTIリソースの提供は、TI製品に対する該当の発行済み保証事項または免責事項を拡張またはいかなる形でも変更するものではなく、これらのTIリソースを提供することによって、TIにはいかなる追加義務も責任も発生しないものとします。TIは、自社のTIリソースに訂正、拡張、改良、およびその他の変更を加える権利を留保します。

お客様は、自らのアプリケーションの設計において、ご自身が独自に分析、評価、判断を行う責任がお客様にあり、お客様のアプリケーション(および、お客様のアプリケーションに使用されるすべてのTI製品)の安全性、および該当するすべての規制、法、その他適用される要件への遵守を保証するすべての責任をお客様のみが負うことを理解し、合意するものとします。お客様は、自身のアプリケーションに関して、(1) 故障による危険な結果を予測し、(2) 障害とその結果を監視し、および、(3) 損害を引き起こす障害の可能性を減らし、適切な対策を行う目的での、安全策を開発し実装するために必要な、すべての技術を保持していることを表明するものとします。お客様は、TI製品を含むアプリケーションを使用または配布する前に、それらのアプリケーション、およびアプリケーションに使用されているTI製品の機能性を完全にテストすることに合意するものとします。TIは、特定のTIリソース用に発行されたドキュメントで明示的に記載されているもの以外のテストを実行していません。

お客様は、個別のTIリソースにつき、当該TIリソースに記載されているTI製品を含むアプリケーションの開発に関連する目的でのみ、使用、コピー、変更することが許可されています。明示的または黙示的を問わず、禁反言の法理その他どのような理由でも、他のTIの知的所有権に対するその他のライセンスは付与されません。また、TIまたは他のいかなる第三者のテクノロジーまたは知的所有権についても、いかなるライセンスも付与されるものではありません。付与されないものには、TI製品またはサービスが使用される組み合わせ、機械、プロセスに関連する特許権、著作権、回路配置利用権、その他の知的所有権が含まれますが、これらに限られません。第三者の製品やサービスに関する、またはそれらを参照する情報は、そのような製品またはサービスを利用するライセンスを構成するものではなく、それらに対する保証または推奨を意味するものでもありません。TIリソースを使用するため、第三者の特許または他の知的所有権に基づく第三者からのライセンス、もしくは、TIの特許または他の知的所有権に基づくTIからのライセンスが必要な場合があります。

TIのリソースは、それに含まれるあらゆる欠陥も含めて、「現状のまま」提供されます。TIは、TIリソースまたはその仕様に関して、明示的か暗黙的にかかわらず、他のいかなる保証または表明も行いません。これには、正確性または完全性、権原、続発性の障害に関する保証、および商品性、特定目的への適合性、第三者の知的所有権の非侵害に対する黙示的保証が含まれますが、これらに限られません。

TIは、いかなる苦情に対しても、お客様への弁済または補償を行う義務はなく、行わないものとします。これには、任意の製品の組み合わせに関連する、またはそれらに基づく侵害の請求も含まれますが、これらに限られず、またその事実についてTIリソースまたは他の場所に記載されているか否かを問わないものとします。いかなる場合も、TIリソースまたはその使用に関連して、またはそれらにより発生した、実際の、直接的、特別、付随的、間接的、懲罰的、偶発的、または、結果的な損害について、そのような損害の可能性についてTIが知らされていたかどうかにかかわらず、TIは責任を負わないものとします。

お客様は、この注意事項の条件および条項に従わなかったために発生した、いかなる損害、コスト、損失、責任からも、TIおよびその代表者を完全に免責するものとします。

この注意事項はTIリソースに適用されます。特定の種類の資料、TI製品、およびサービスの使用および購入については、追加条項が適用されます。これには、半導体製品(<http://www.ti.com/sc/docs/stdterms.htm>)、評価モジュール、およびサンプル(<http://www.ti.com/sc/docs/sampterms.htm>)についてのTIの標準条項が含まれますが、これらに限られません。