

TI Designs: TIDA-01530 車載用ウィンドシールド・ワイパー駆動のリファレンス・デザイン



概要

このリファレンス・デザインは、車載用で2つの速度が選択できるフロント・ガラス・ワイパー、1個か2個のリア・ワイパー、およびフロント・ウィンドウとリア・ウィンドウへの噴射用ポンプを駆動します。ワイパーおよびポンプ用のブラシ付きモータの制御に加えて、このデザインにはワイパーのパークリング信号用の入力と、診断および保護機能が含まれています。テスト・データは、代表的な車載用ワイパー・メカニズムと組み合わせた場合の性能を示しています。包括的なデザイン・ファイルを活用すると、自動車の設計者が新規プロジェクトの開発を迅速化することができます。

リソース

TIDA-01530	デザイン・フォルダ
DRV8702-Q1	プロダクト・フォルダ
DRV8702D-Q1	プロダクト・フォルダ
INA300-Q1	プロダクト・フォルダ
TPS7B69-Q1	プロダクト・フォルダ
TMP302-Q1	プロダクト・フォルダ

特長

- フロント・ワイパーとリア・ワイパーのモーターを駆動
- 双方向の液体噴射ポンプを駆動
- 12Vの車載用バッテリーで動作
- バッテリ逆接続保護
- 単純なコントローラ・インターフェイス
- オンボードの3.3V電源

アプリケーション

- ブラシ付きDC単方向フロント・ワイパー
- ブラシ付きDC単方向リア・ワイパー (シングルまたはデュアル)
- 双方向のブラシ付きDC噴射ポンプ

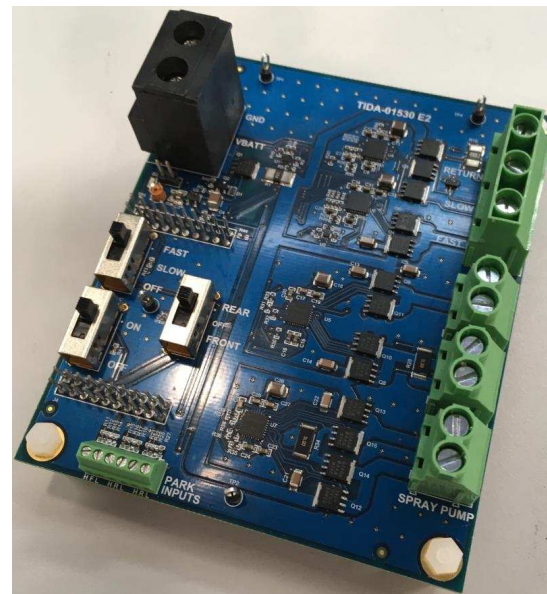
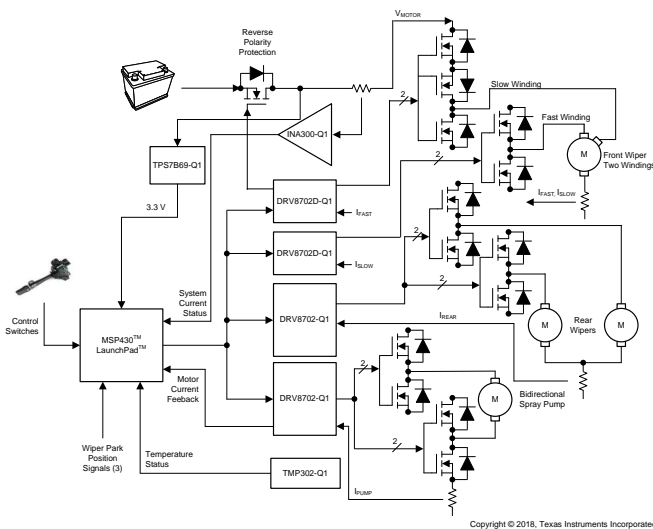
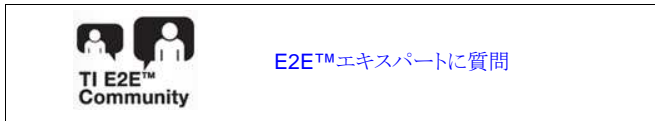



使用許可、知的財産、その他免責事項は、最終ページにあるIMPORTANT NOTICE(重要な注意事項)をご参照くださいますようお願いいたします。英語版のTI製品についての情報を翻訳したこの資料は、製品の概要を確認する目的で便宜的に提供しているものです。該当する正式な英語版の最新情報は、www.ti.comで閲覧でき、その内容が常に優先されます。TIでは翻訳の正確性および妥当性につきましては一切保証いたしません。実際の設計などの前には、必ず最新版の英語版をご参照くださいますようお願いいたします。

1 System Description

This reference design is implemented as a small BoosterPack™ board, with only two layers to keep the design cost-effective. The simple 40-pin interface to an external microcontroller conforms to the LaunchPad™ 40-pin standard; the testing described in this design guide is performed using an MSP430F5529 LaunchPad with code based on examples already available on TI.com. The reference design is powered by a standard 12-V automotive battery system and is protected against reverse battery conditions and high voltage up to 40 V as might be experienced during a load dump event. When placed in shutdown mode, the entire design has an input current less than 120 μA, allowing this design to be connected directly to the battery system without excessive battery current drain. The components selected for this reference design are rated for automotive applications.

1.1 Key System Specifications

表 1. Key System Specifications

PARAMETER	SPECIFICATIONS
Front wiper type	Brushed motor, unidirectional, single motor, two speed windings
Rear wiper type	Brushed motor, unidirectional, single or dual motor
Spray pump type	Brushed motor, bidirectional, single motor
Input power supply voltage range (operational)	6 V to 18 V
Input power supply voltage range (survivable)	-20 V (reverse battery) up to 40 V (load dump)
Front wiper park position sensor input	Make or break connection, positive or inverted logic
Rear wiper park position sensor input	Make or break connection, positive or inverted logic
Total current from VBATT (maximum)	50 A
Front wiper motor current (maximum), each winding	30 A
Rear wiper motor current (maximum), each motor	20 A
Washer pump current (maximum), either direction	20 A
Shutdown current from VBATT	< 120 μA
Board layers	Two
Board form factor	BoosterPack

2 System Overview

2.1 Block Diagram

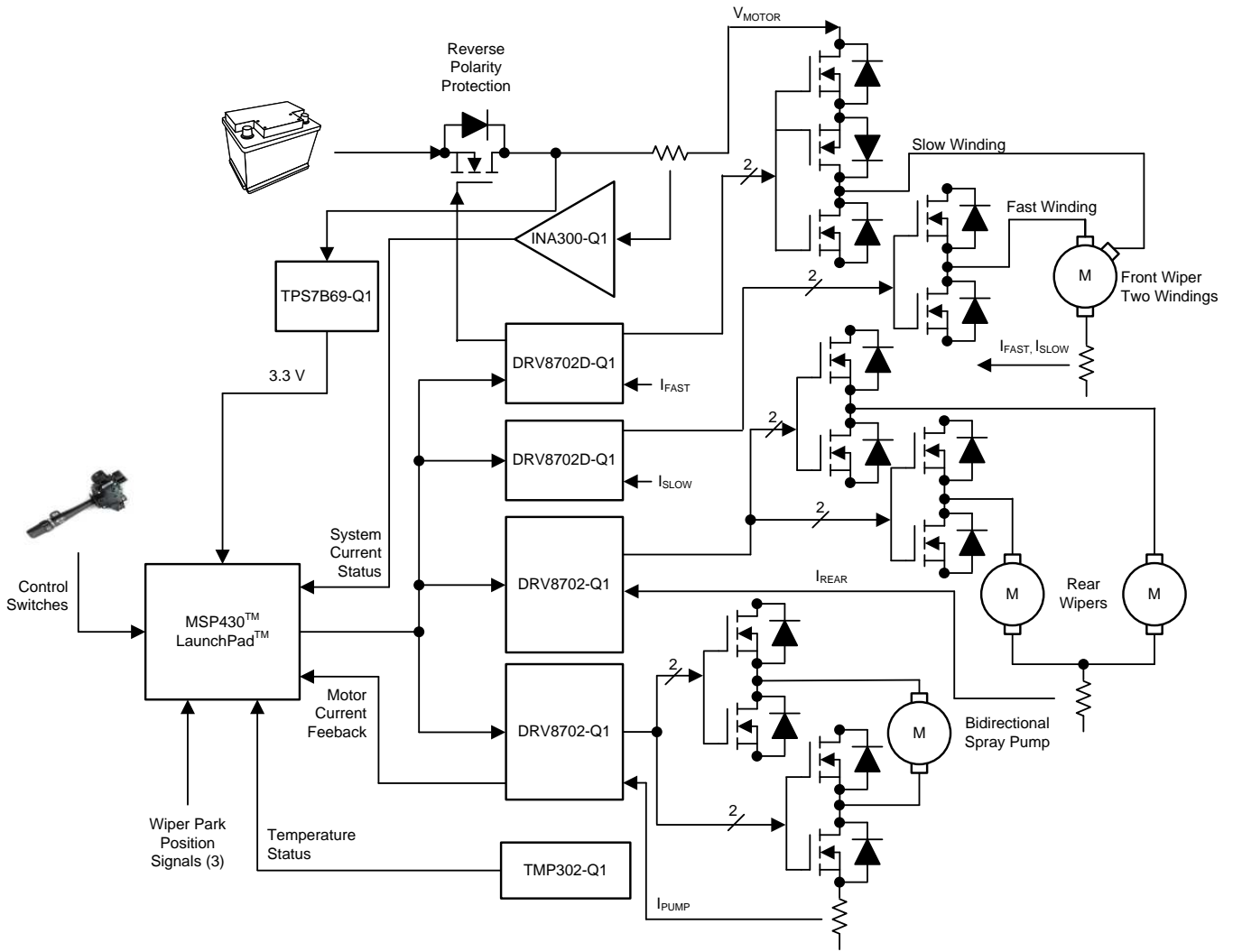

Copyright © 2018, Texas Instruments Incorporated

図 1. Block Diagram of TIDA-01530

2.2 Design Considerations

To simplify this reference design and make the design more adaptable to a variety of microcontroller units (MCUs), the board is implemented in the BoosterPack format. This board format has a simple connector interface to the external LaunchPad MCU board, which allows this reference design to be evaluated with a wide selection of MCUs. The LaunchPad plus BoosterPack implementation also has the advantage that code development and design testing are facilitated by existing tools such as Code Composer Studio™ or Energia, thus speeding up optimization of the design for any specific operating conditions. While the BoosterPack format does allow flexibility in using different MCU boards, the format also creates constraints on the size and layout of the windshield wiper drive board. In a production version of this design, the MCU would likely be installed on the same board with the DRV8702-Q1 chips and other components with a possible reduction in board size.

Another consideration is selecting the passive components. In general, components are selected based on the performance requirements of the expected applications. Where practical, components with automotive ratings are selected. For active components, the components selected are AEC-Q100 qualified to either temperature grade 0 or temperature grade 1.

Capacitors are generally X7R grade (-55°C to $+125^{\circ}\text{C}$) or higher with size and value selected for the expected extremes of operation conditions. The voltage rating of the capacitors must be greater than the maximum voltage they could experience and two times the typical operating voltage to avoid DC bias effects. The amount of output capacitance used depends on output ripple and transient response requirements, and many equations and tools are available online to help estimate these values.

2.3 Highlighted Products

2.3.1 DRV8702D-Q1

The DRV8702D-Q1 is a single half-bridge gate driver that uses two external N-channel MOSFETs targeted to drive a unidirectional brushed-DC motor. A PH/EN, independent H-Bridge, or PWM interface allows simple interfacing to controller circuits. An internal sense amplifier provides adjustable current control. The gate driver includes circuitry to regulate the winding current using fixed off-time PWM current chopping. The DRV8702D-Q1 drives both high-side and low-side FETs with a 10.5-V V_{GS} gate drive. The gate drive current for the external FETs is configurable with a single external resistor. A low-power sleep mode is provided, which shuts down internal circuitry to achieve a very-low quiescent-current draw.

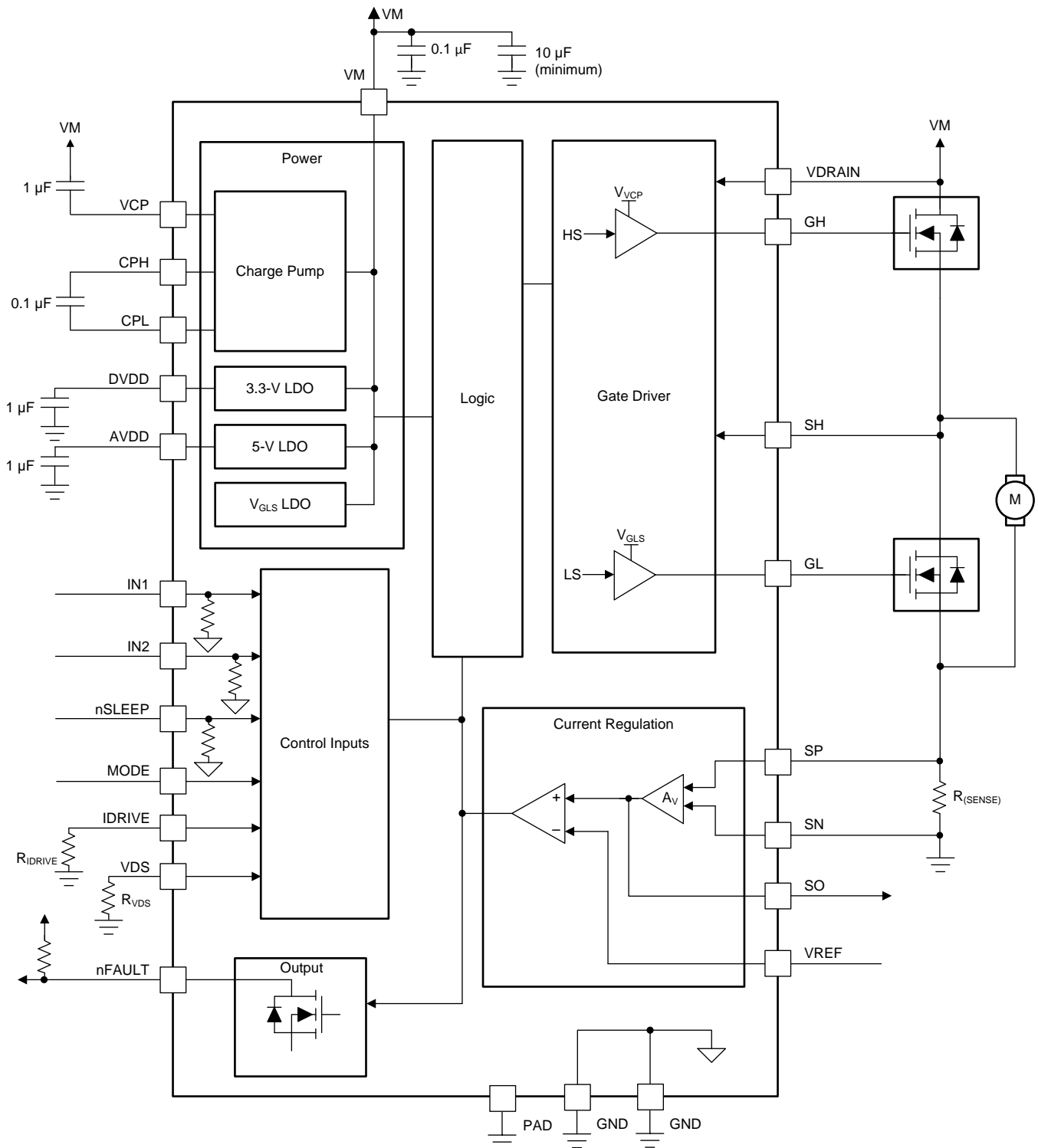

Copyright © 2017, Texas Instruments Incorporated

図 2. Block Diagram of DRV8702D-Q1

2.3.2 DRV8702-Q1

The DRV8702-Q1 is a single full-bridge gate driver that uses four external N-channel MOSFETs targeted to drive a bidirectional brushed-DC motor. A PH/EN, independent H-Bridge, or PWM interface allows simple interfacing to controller circuits. An internal sense amplifier provides adjustable current control. The gate driver includes circuitry to regulate the winding current using fixed off-time PWM current chopping. The DRV8702-Q1 drives both high-side and low-side FETs with a 10.5-V V_{GS} gate drive. The gate drive current for all external FETs is configurable with a single external resistor. A low-power sleep mode is provided, which shuts down internal circuitry to achieve a very-low quiescent-current draw.



図 3. Block Diagram of DRV8702-Q1

2.3.3 INA300-Q1

The INA300-Q1 is a high common-mode, current-sensing comparator that detects overcurrent conditions by measuring the voltage developed across a current-sensing or shunt resistor. The device measures this differential voltage signal on common-mode voltages that can vary from 0 V up to 36 V, independent of the supply voltage. The INA300-Q1 device features an adjustable threshold range that is set using a single external limit-setting resistor. A selectable hysteresis feature enables adjustable operation of the comparator to accommodate the wide input signal range of 0 mV to 250 mV. An open-drain alert output on the device can be configured to operate in either a transparent mode where the output status follows the input state, or in a latched mode where the alert output is cleared when the latch is cleared. The device response time setting is selectable, which enables overcurrent alerts to be issued in as fast as 10 μ s. The INA300-Q1 device operates from a single 2.7-V to 5.5-V supply, drawing a maximum supply current of 135 μ A. The INA300-Q1 device is specified over the extended operating temperature range of -40°C to $+125^{\circ}\text{C}$, and is available in a VSSOP-10 package.

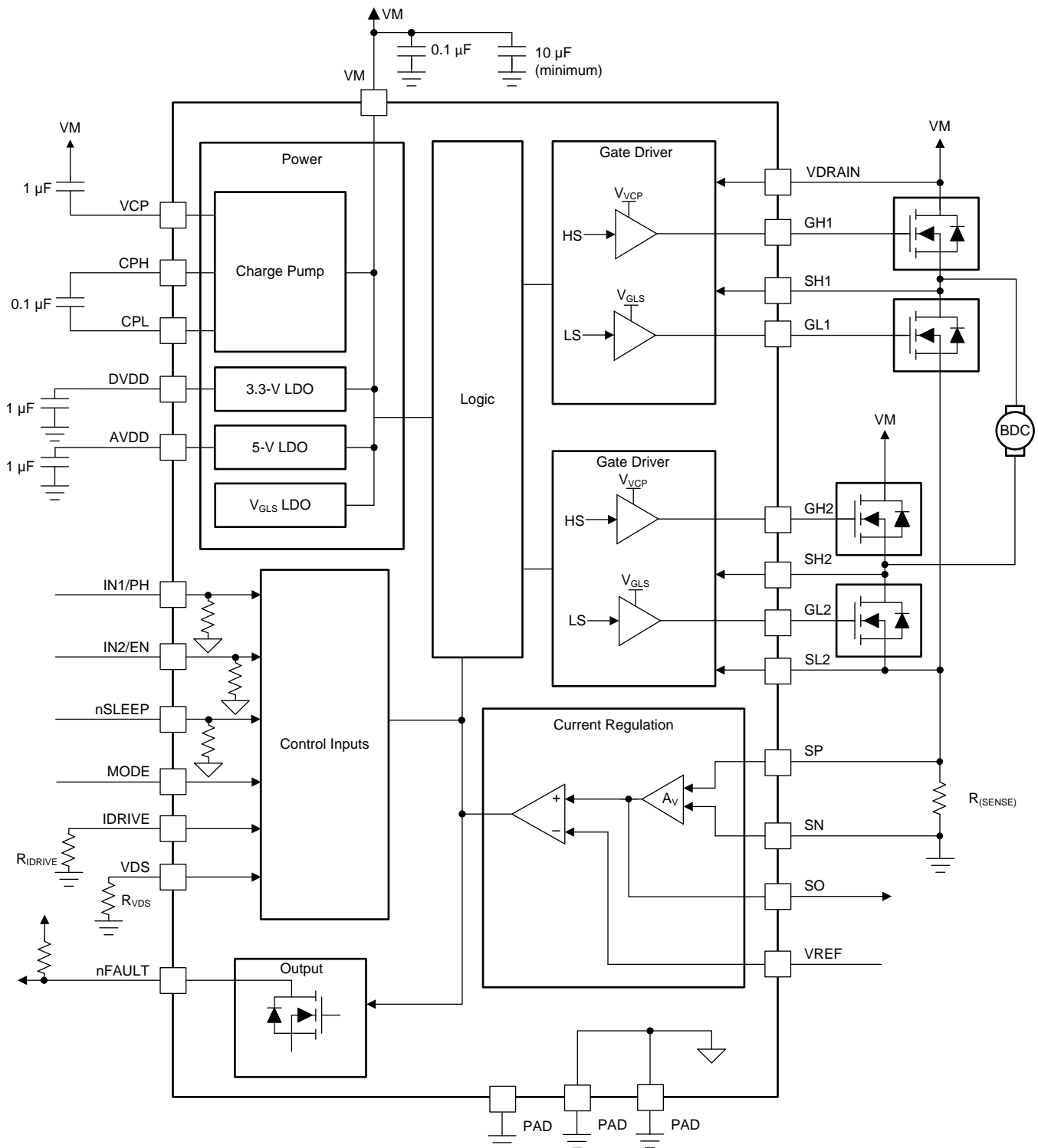
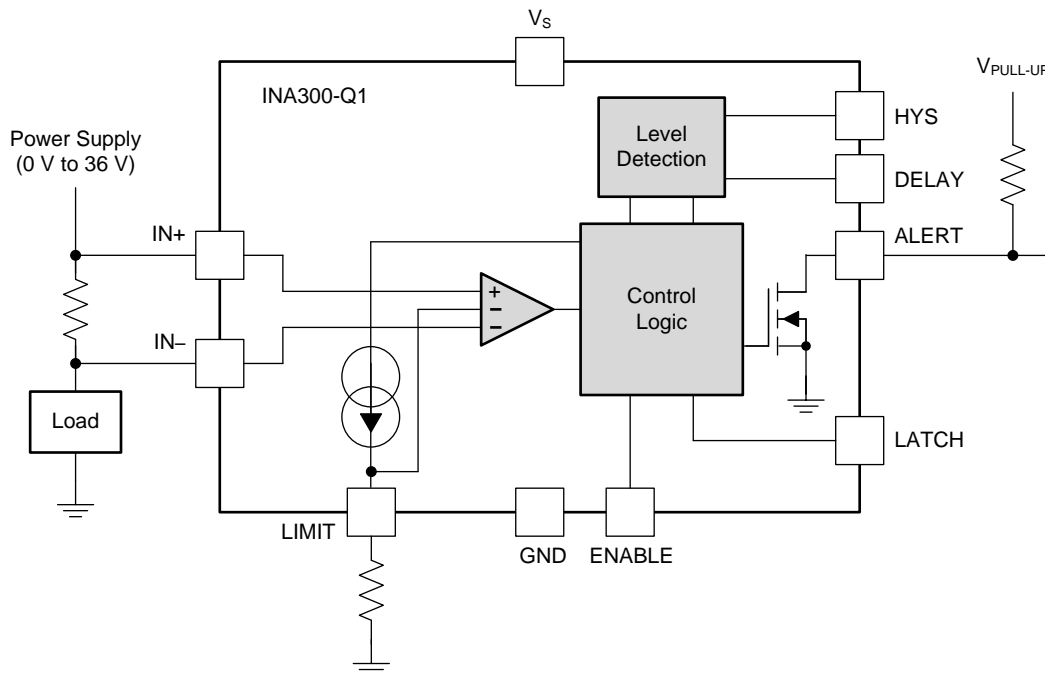

Copyright © 2016, Texas Instruments Incorporated

図 4. Block Diagram of INA300-Q1

2.3.4 TPS7B69-Q1

The TPS7B69xx-Q1 device is a low-dropout linear regulator designed for up to 40-V operations. With only 15- μ A (typical) quiescent current at light load, the device is suitable for standby micro-controller unit systems especially in automotive applications. The devices feature an integrated short-circuit and overcurrent protection. The TPS7B69xx-Q1 device operates over a -40°C to $+125^{\circ}\text{C}$ temperature range. Because of these features, the TPS7B6925-Q1, TPS7B6933-Q1, and TPS7B6950-Q1 devices are well suited in power supplies for various automotive applications.

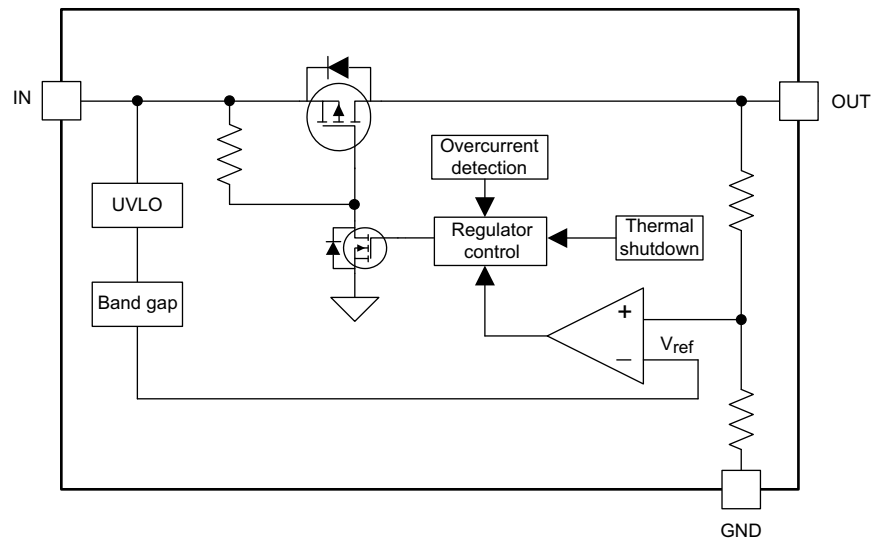

Copyright © 2016, Texas Instruments Incorporated

図 5. Block Diagram of TPS7B69-Q1

2.3.5 TMP302-Q1

The TMP302-Q1 family of devices is a temperature switch in a micropackage (SOT563). The TMP302-Q1 family of devices offers low power (15 μ A maximum) and ease-of-use through pin-selectable trip points and hysteresis. These devices require no additional components for operation; they can function independent of microprocessors or microcontrollers. The TMP302-Q1 family of devices is available in several different versions with trip points from 50°C to 125°C in increments of 5°C.



図 6. Block Diagram of TMP302-Q1

2.4 System Design Theory

2.4.1 Front Wiper Drive Circuits

A common arrangement for front windshield wipers is to have a single motor that drives both front wipers through a series of gears and linkages which convert the high-speed unidirectional rotary motion of the motor to a reduced-speed, high-torque reciprocating motion of the wiper blades. This type of system is a dual-winding motor, with one winding designed for slow-speed wiping and the other winding designed for high-speed wiping. Although there are two windings, the wipers are mechanically coupled on the same shaft to drive the common mechanical gears and linkages. Thus, applying electrical power to either winding causes the wiper mechanism to wipe.

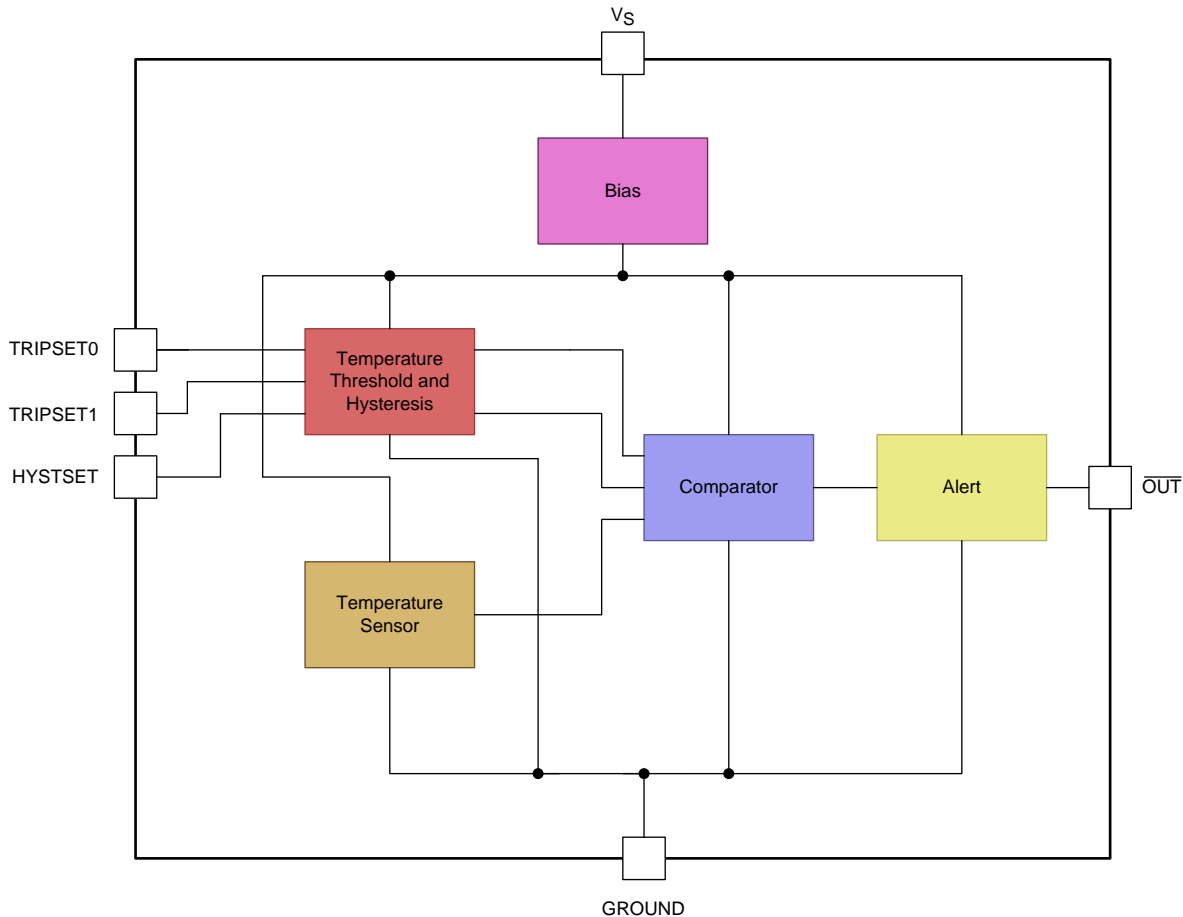
2.4.1.1 Fast Speed Drive Circuit

Figure 7 shows the electrical schematic for the fast speed drive circuit. The DRV8702D-Q1 (U6) responds to commands from the MCU to drive the half-bridge FETs Q4 and Q6. These FETs are rated for up to 60 V across the drain to source to withstand transients on VMOTOR due to load dump. The FETs are rated for up to 33 A of continuous drain current at temperatures of 125°C and are automotive grade AEC-Q101 qualified.

Capacitors C29 and C30 are decoupling capacitors as suggested by the DRV8702D-Q1 data sheet. The voltage on AVDD is nominally 5 V; the voltage on DVDD is nominally 3.3 V. Capacitors C32 and C33 are decoupling capacitors for VM and VDRAIN, which are connected to the 12-V nominal VMOTOR supply.

C31 and C34 are the charge pump capacitors. Their values and ratings are as specified by the DRV8702D-Q1 data sheet.

R52 allows the MODE pin (U6-11) to be either connected to a logic high state (through R52 to DVDD) or left open (with R52 not installed).

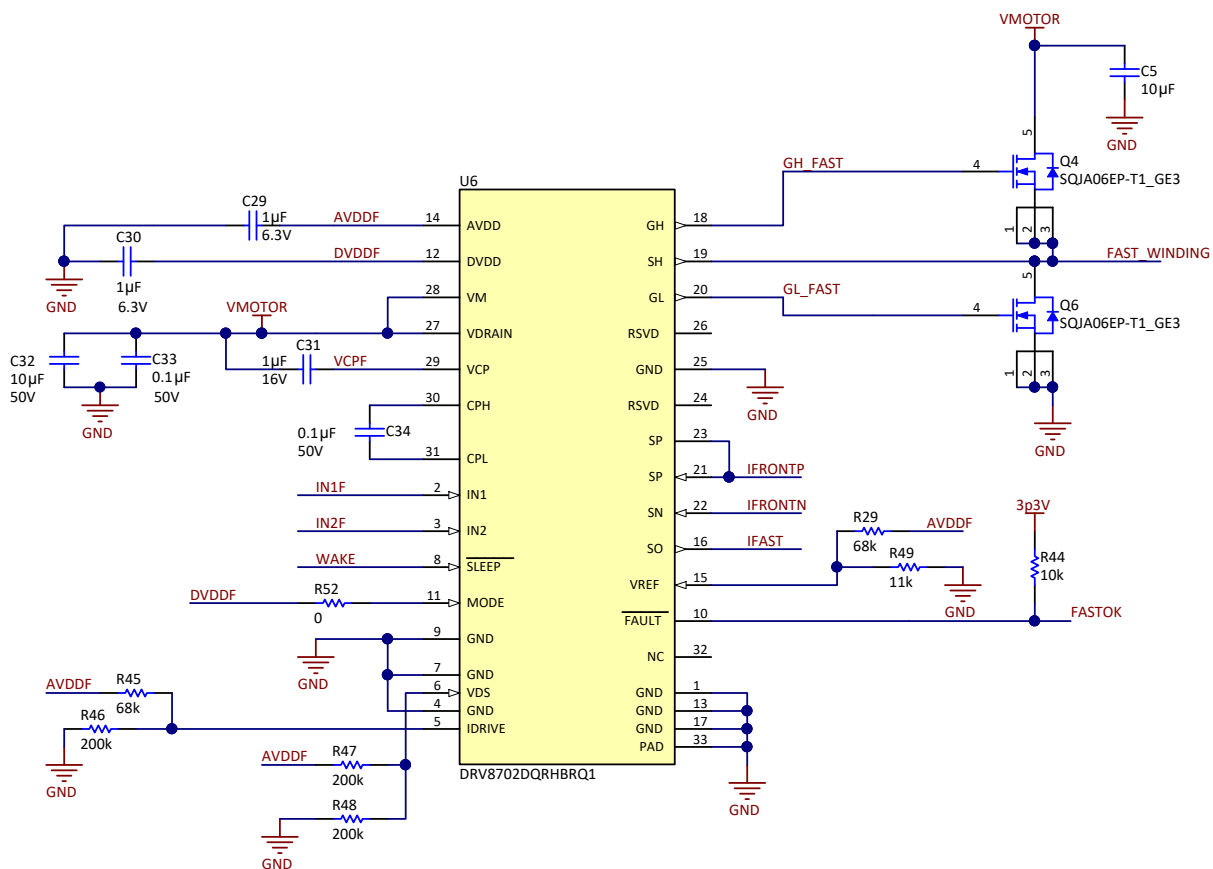

Copyright © 2018, Texas Instruments Incorporated

Figure 7. Electrical Schematic of Front Wiper Drive Circuit (Fast Speed)

2.4.1.2 Slow Speed Drive Circuit

The slow speed wiper drive circuit is similar to the fast speed wiper drive circuit. However, due to the way the two windings are mechanically coupled, there are additional requirements for the slow speed circuit. Figure 8 shows the schematic for the slow speed wiper drive circuit.

Resistors R23 and R26 set the current drive level with which the DRV8702-Q1 drives the gates of the drive transistors. With R23 installed and R26 not installed, the gate drive current for each MOSFET is about 200 mA (source) and about 350 mA (sink), giving relatively quick turnon and turnoff times. With R23 not installed and R26 installed, the gate drive current for each MOSFET is about 50 mA (source) and about 95 mA (sink), giving slower turnon and turnoff times, which can improve electromagnetic compatibility (EMC) performance. The sink current is higher than the source current to help ensure that the transistor being turned off changes state before the resistor being turned on. This sequence prevents unintentional shoot-through currents.

The MODE input (U4 pin 11) can be left open or connected directly to the digital supply DVDD (U4 pin 12). With MODE at a logic HIGH level, the DRV8702-Q1 device is configured without drive current regulation. With the MODE pin open (R53 not installed), the DRV8702D-Q1 implements current regulation, and it is also possible to turn off both the low-side and high-side drive FETs.

The drive stage transistors Q3, Q5, and Q7 are automotive-grade (AEC-Q101 qualified) MOSFETs with a $V_{DS(MAX)}$ rating of 60 V. For a case temperature of 125°C, the maximum continuous drain current rating is 33 A.

2.4.1.3 Motor Current Regulation

When the wiper motor is activated, there is no back EMF from the stationary motor, so the motor current is limited only by the impedance of the winding. To regulate the motor current, the current is chopped by a fixed off-time pulse width modulation on the gate drive signal from the DRV8702D-Q1. The resistors R29 and R49 set the value of VREF for the fast-speed winding, as described in the DRV8702D-Q1 data sheet. With values of 68 kΩ and 11 kΩ for R29 and R49, respectively, the voltage at VREF is about 14% of AVDD, which for the nominal value of AVDD of 5V, gives VREF equal to 700 mV.

Using 式 1 from the DRV8702D-Q1 data sheet, the maximum motor current can be calculated as:

$$I_{(CHOP)} = \frac{V_{VREF} - V_{IO}}{A_V \times R_{(SENSE)}} \quad (1)$$

Resistors R50 and R55 set VREF for the slow-speed winding, giving the same value for the maximum current as the fast-speed winding.

2.4.2 Rear Wiper Drive Circuit

図 9 shows the electrical schematic of the rear wiper drive section of the board. Each half-bridge circuit (for example, Q8 and Q10) is capable of driving a brushed DC motor in one direction independently of the other motor drive circuits on the board. With the DRV8702-Q1 MODE pin (U5-11) connected to DVDDR pin (U5-12), the MODE signal is at a logic high, and the DRV8702-Q1 operates in Independent PWM Control mode. In this mode, a single DRV8702-Q1 can drive the gates of two separate half-bridges. The two half-bridges can be used to drive two DC brushed motors, which drive two separate rear wipers. This configuration is found on automobiles with two rear doors, each with its own wiper.

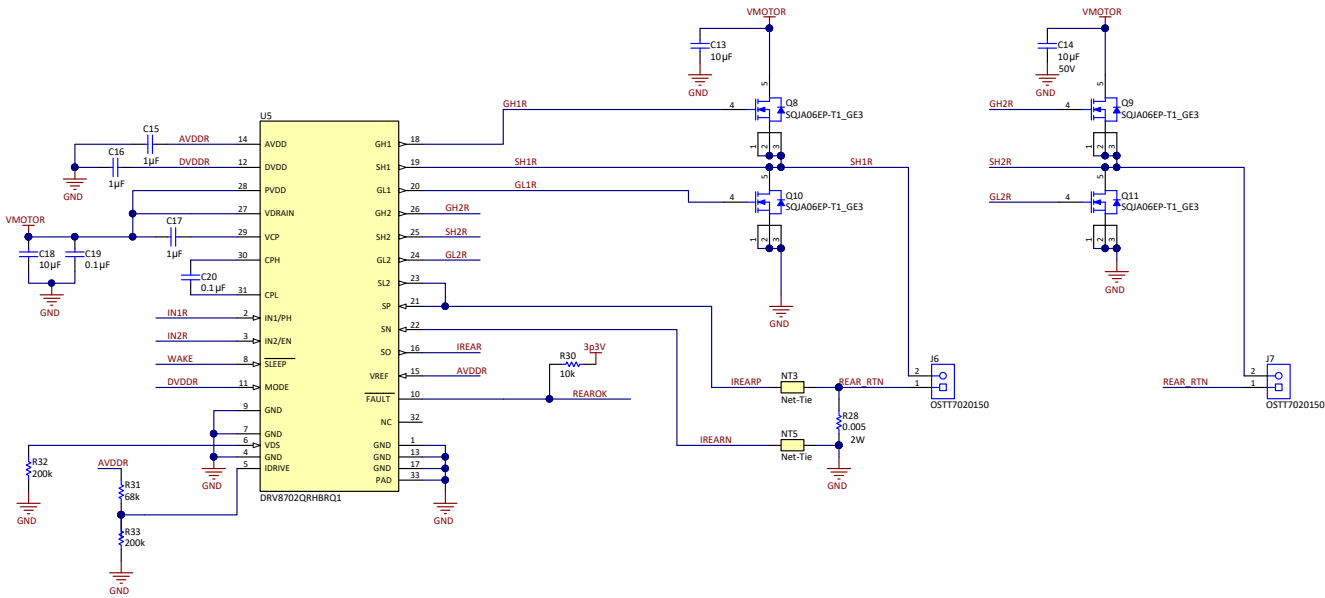

Copyright © 2018, Texas Instruments Incorporated

図 9. Electrical Schematic of Rear Wiper Drive

The drive stage transistors Q8 to Q11 are the same automotive-grade (AEC-Q101 qualified) MOSFETs with a $V_{DS(MAX)}$ rating of 60 V as used for the front wiper circuits. For a case temperature of 125°C, the maximum continuous drain current rating is 33 A.

Resistors R31 and R33 set the current drive level with which the DRV8702-Q1 drives the gates of the drive transistors. With R31 installed and R33 not installed, the gate drive current for each MOSFET is about 200 mA (source) and about 350 mA (sink), giving relatively quick turnon and turnoff times. With R31 not installed and R33 installed, the gate drive current for each MOSFET is about 50 mA (source) and about 95 mA (sink), giving slower turnon and turnoff times, which can improve electromagnetic compatibility (EMC) performance. The sink current is higher than the source current to help ensure that the transistor being turned off changes state before the resistor being turned on. This sequence prevents unintentional shoot-through currents.

The low-side return current from both rear wiper motors is sensed through resistor R28. This is a 5-mΩ resistor with a power rating of 2 W, allowing up to 20 A of motor current. The voltage across the resistor is a measure of the motor current with a scale factor of 5 mV/A.

The motor current signal is amplified by the current sense amplifier in the DRV8702-Q1 with a fixed gain of 20 giving a scale factor of 100 mV/A for the rear wiper motor current signal, IREAR.

If only a single rear wiper is needed, the DRV8702-Q1 (U5) can be replaced with the DRV8702D-Q1, which is a more cost-effective way to drive a single half-bridge. For the case of a single rear wiper motor, Q9, Q11, and C14 can also be omitted.

2.4.3 Spray Pump Drive Circuit

図 10 shows the electrical schematic of the windshield washer spray pump drive section of the board. This circuit is a full-bridge driver that provides power to a bidirectional pump motor as described in 3.2.2.4.

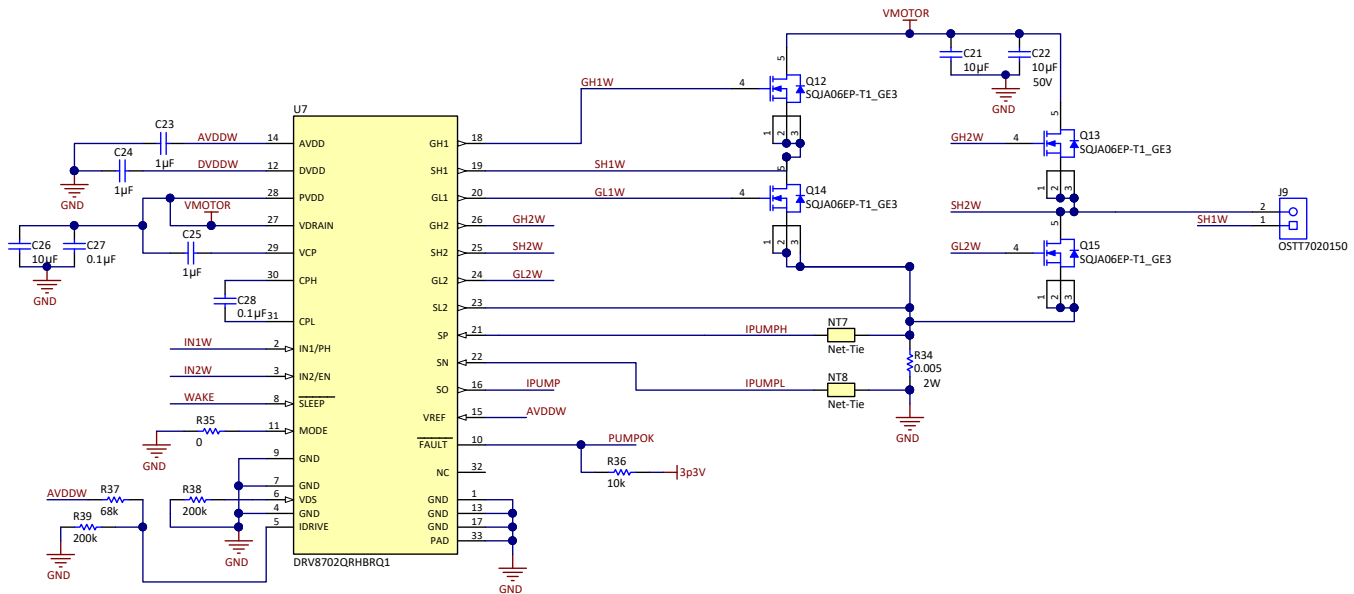

Copyright © 2018, Texas Instruments Incorporated

図 10. Electrical Schematic of Spray Pump Drive

Resistors R37 and R39 set the current drive level with which the DRV8702-Q1 drives the gates of the drive transistors. With R37 installed and R39 not installed, the gate drive current for each MOSFET is about 200 mA (source) and about 350 mA (sink), giving relatively quick turnon and turnoff times. With R37 not installed and R39 installed, the gate drive current for each MOSFET is about 50 mA (source) and about 95 mA (sink), giving slower turnon and turnoff times, which can improve electromagnetic compatibility (EMC) performance. The sink current is higher than the source current to help ensure that the transistor being turned off changes state before the resistor being turned on. This sequence prevents unintentional shoot-through currents.

The low-side return current from the pump motor is sensed through resistor R34. This is a 5-mΩ resistor with a power rating of 2 W, allowing up to 20 A of motor current. The voltage across the resistor is a measure of the motor current with a scale factor of 5 mV/A. This voltage connects to the inputs of the current sense amplifier in the DRV8702-Q1 (U7) where it is amplified by a fixed amplification of 20, producing the IPUMP signal. This signal measures the pump motor current with a scale factor of 100 mV/A.

2.4.4 Reverse Battery Protection Circuit

図 11 shows the electrical schematic of the reverse battery protection section of the board.

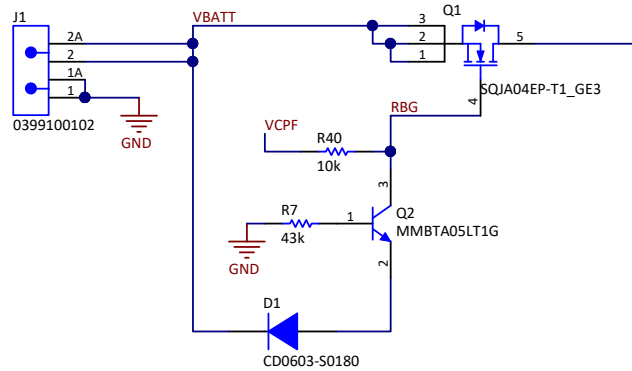

Copyright © 2018, Texas Instruments Incorporated

図 11. Electrical Schematic of Reverse Battery Protection Circuit

2.4.4.1 Normal Polarity

When the polarity of the applied battery voltage (VBATT) is positive with respect to GND, current can pass through the body diode of transistor Q1 to VIN+, supplying U6, the DRV8702D-Q1 that drives the fast winding of the front windshield wiper. If the WAKE signal is asserted (logic high), then the U6 charge pump voltage VCPF will be several volts higher than VIN+. As VCPF is applied to the gate of Q1, the transistor is turned on, reducing the voltage drop from VBATT to VIN+ and allowing the design board to be fully powered.

If the WAKE signal is not asserted (WAKE = logic low), the U6 charge pump will be inactive, and Q1 will not be on. Therefore, when WAKE is not asserted, there is a voltage drop from VBATT to VIN+ due to the body diode of Q1. This drop must not cause any significant power dissipation issues because the current when WAKE is logic low should be very small.

During normal (positive) VBATT polarity, the base of Q2 is at GND, and Q2 is off, having no effect on the circuit.

2.4.4.2 Reverse Polarity

When the polarity of the applied battery voltage VBATT is negative with respect to GND, the body diode of Q1 blocks any current flow from VBATT to VIN+. To ensure that Q1 is off, the bipolar npn transistor Q2 is turned on by a base current flowing from GND through R7. Whenever the voltage at VBATT is more negative with respect to GND than two diode drops (VBE of Q2 plus the forward drop of D1), then Q2 is on and pulls the gate of Q1 to a negative value.

2.4.5 Power Supply Circuit

The power supply converts the 12-V automotive battery voltage to the 3.3-V supply needed by the microcontroller and the other components. The requirements for the power supply circuit are to produce a stable 3.3-V supply capable of at least 35 mA, while surviving electrical conditions such as reverse-battery and load-dump. The TPS7B6933-Q1 provides regulation of a fixed 3.3-V supply and has a wide survivable input voltage range up to 45 V. The TPS7B6933-Q1 device is stable with ceramic output capacitors, which is preferred for automotive applications. 図 12 shows the electrical schematic of the power supply circuit.

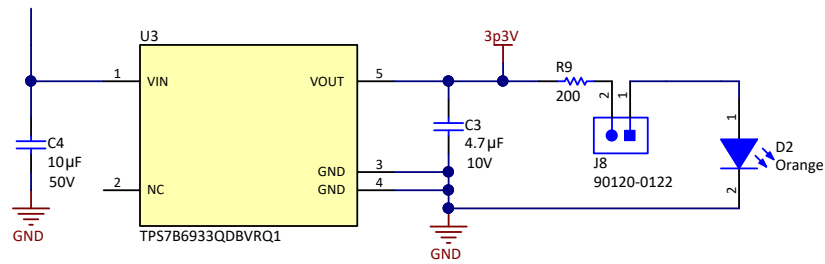

Copyright © 2018, Texas Instruments Incorporated

12. Electrical Schematic of Power Supply

The input capacitor C4 has a capacitance value of 10 µF in accordance with the guidance in the TPS7B69-Q1 data sheet. The voltage rating of C4 is 50 V to allow overvoltage conditions such as load dump without damage to the capacitor. The output capacitor C3 has a capacitance value of 4.7 µF in accordance with the guidance in the TPS7B69-Q1 data sheet.

The light-emitting diode (LED) D2 is a visual indicator that the 3.3-V supply is operating. Jumper J8 allows the LED to be disconnected from the 3.3-V supply to make low-power mode current measurements.

2.4.6 System Current Sense Circuit

13 shows the electrical schematic of the front wiper drive section of the board.

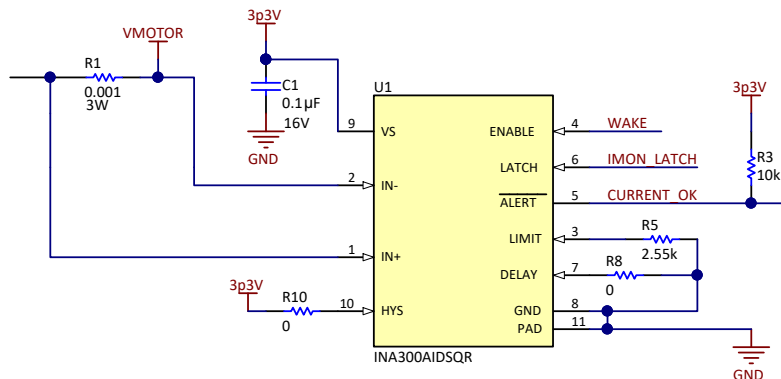

Copyright © 2018, Texas Instruments Incorporated

13. Electrical Schematic of System Current Sense

The in-line current sense resistor R1 has a resistance value of 1 mΩ, and is rated for 3 W of power dissipation. This resistor allows for total system currents up to 54 A without exceeding the resistor power ratings.

Resistor R8 sets the delay time for the INA300-Q1 to indicate a current fault. If R8 is installed, the DELAY pin is tied to ground, and the INA300-Q1 ALERT delay is 50 µs. If R8 is not installed, the ALERT delay is 10 µs.

Resistor R5 sets the current limit threshold for the INA300-Q1. The 2.55-kΩ value and the 20-µA internal current source give a limit voltage of 51 mV. A sense resistor (R1) value of 1 mΩ corresponds to a current threshold of 51 A. If the current through R1 exceeds the current threshold for a duration longer than the ALERT delay, the CURRENT_OK output is pulled to a logic low level, indicating an overcurrent condition. In normal operation, the open drain ALERT output pin is pulled high by resistor R3.

Resistor R10 sets the hysteresis of the current limit threshold. If R10 is installed, the hysteresis level of the limit voltage is 8 mV, corresponding to a current level of 43 A across R1 for the ALERT signal to be reset. If R10 is not installed, the hysteresis level of the limit voltage is 2 mV, corresponding to a current level of 49 A across R1 for the ALERT signal to be reset.

The LATCH pin (U1-6) is an input to the INA300-Q1 that selects whether the ALERT output signal is momentary or latched when a current fault occurs. In latch mode, when an overlimit condition is detected and the ALERT terminal is pulled low, the ALERT terminal does not return to the default high level when the differential input signal drops below the alert threshold level for 10 μs. To clear the alert, the LATCH terminal must be pulled low for at least 20 μs. Pulling the LATCH terminal low allows the ALERT terminal to return to the default high level, provided that the differential input signal has dropped below the alert threshold. If the input signal is still above the threshold limit when the LATCH terminal is pulled low, the ALERT terminal remains low. When the alert condition is detected by the system controller, the LATCH terminal can be set back to high to place the device back in latch mode.

2.4.7 Temperature Sense Circuit

Figure 14 shows the electrical schematic of the temperature sensing section of the board. The TMP302-Q1 has four selectable temperature thresholds. As shown, TRIPSET0 is connected to a logic high (3p3V) level, and TRIPSET1 is connected to a logic low (GND) level. This combination sets the temperature threshold to 115°C; when the sensed temperature reaches the threshold, the open-drain output signal TEMPOK changes to the active low state. Resistors R4 and R6 facilitate changing the TRIPSET levels to select a different temperature threshold.

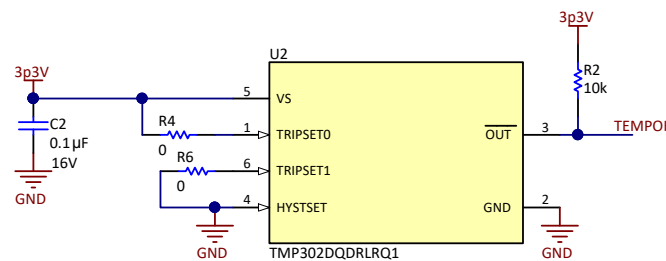

Copyright © 2018, Texas Instruments Incorporated

Figure 14. Electrical Schematic of Temperature Sense Circuit

The signal HYSTSET is tied to GND, which sets the threshold hysteresis to 5°C. The open-drain TEMPOK signal then resets to a high-impedance state when the sensed temperature drops to 110°C. Resistor R2 pulls the high-impedance output signal to a logic high state.

2.4.8 Controller Interface

Figure 15 shows the electrical schematic of the controller interface section of the board. Table 2 lists the signals between the reference design board and the LaunchPad board.

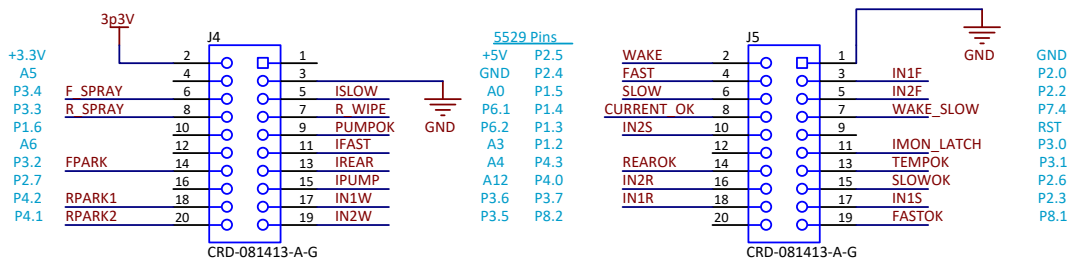

Copyright © 2018, Texas Instruments Incorporated

Figure 15. Electrical Schematic of Controller Interface

2.4.9 Park Position Interface

After the operator has turned them off, windshield wipers commonly continue to move until they reach a park position, usually at the bottom or side of the windshield. One method to sense when the wiper has reached the park position is to have a rotating segment inside the wiper mechanism, with a different electrical state for the park position than all other positions. The segments shown in Figure 16 illustrate two examples of this type of park position segment. For the case where the park position is electrically open, a brush is in contact with the rotating segment and makes electrical contact for all positions except the park position. The park position is thus indicated by an open circuit. Conversely, for the case where a segment is used with only the park position making electrical connection through a brush contact, the park position is indicated by an electrical short circuit.

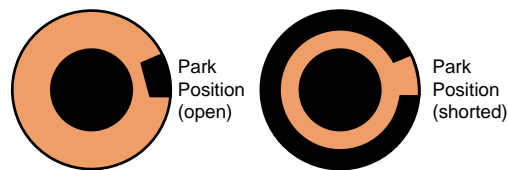
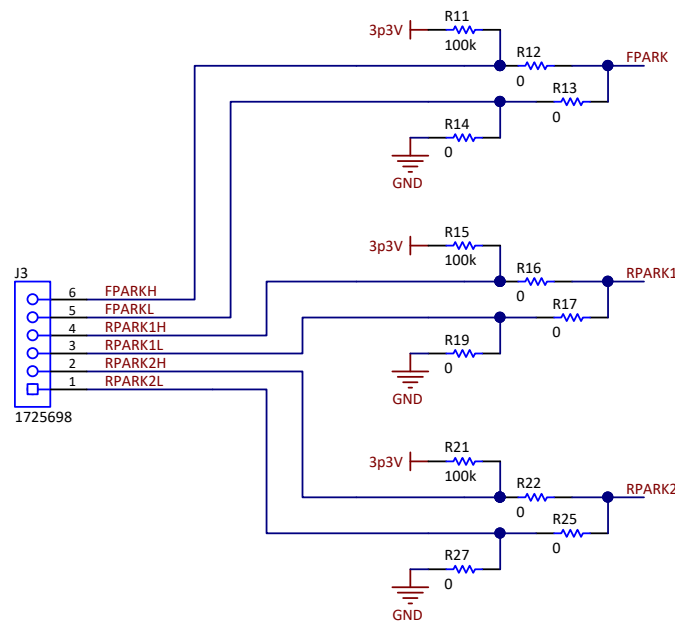

Figure 16. Park Position Segments With Open Park Position (Left) and Shorted Park Position (Right)

Figure 17 shows the electrical schematic of the park position sensor interface section of the board. This interface includes two inputs for each of the three wiper mechanisms; front, left rear, and right rear. Each pair of inputs can be configured for parking signals that are in one of two common configurations:

- Parking signals are electrically shorted when in the park location and electrically open if not in the park location.
- Parking signals are electrically open when in the park location and electrically shorted if not in the park location.

Using the circuit for the front wiper as an example, if R12 is installed and R13 is not installed, the FPARK signal will be logic high when FPARKH (J3-6) is not connected to FPARKL (J3-5) and logic low when FPARKH is connected to FPARKL through the front wiper park segment. To invert the logic levels corresponding to the shorted and open signal conditions, exchange the resistance values of R11 and R14, and do not install R12 with R13 installed.



Copyright © 2018, Texas Instruments Incorporated

図 17. Electrical Schematic of Park Position Interface

2.4.10 User Switch Interface

図 18 shows the electrical schematic of the user switch interface section of the board. These switches allow local inputs to control the signals to the microcontroller and mimic the operation of the user switches in the automobile. Each signal is connected through the controller interface (connectors J4 and J5) to the general-purpose input/output (GPIO) pins on the external microcontroller. The selected signal is connected to a logic low state (GND) and is otherwise pulled to a logic high state by the pullup resistors on the microcontroller GPIO pins.

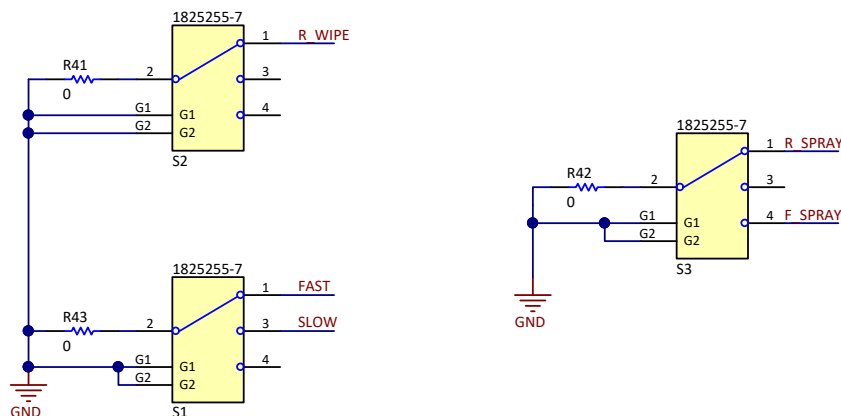

Copyright © 2018, Texas Instruments Incorporated

図 18. Electrical Schematic of User Switch Interface

The resistors R41, R42, and R43 provide a way to disconnect from GND and wire a logic high signal to the switch common connections. This arrangement allows switching the logic polarity to high-level on the selected signal.

3 Hardware, Software, Testing Requirements, and Test Results

3.1 Required Hardware and Software

3.1.1 Hardware

In addition to the reference design board, a compatible microcontroller board such as the MSP430F5529 LaunchPad is required to exercise all the features of this design. Windshield wiper hardware is also required, including a two-speed front wiper mechanism, at least one rear wiper mechanism, and a two-directional spray pump. A power supply capable of providing at least 10 A at 12 V is to operate all the features at the same time if desired.

3.1.2 Software

This reference design is intended to be used with an MSP430F5529 LaunchPad board (MSP-EXP430F5529LP). Other microcontrollers may be used, taking advantage of the simple interface provided on connectors J4 and J5.

表 2. GPIO Settings

SIGNAL	DESCRIPTION	GPIO	SOURCE	DESTINATION
FAST	Fast front wiper signal from user switch	P2.4	TIDA-01530	LaunchPad
SLOW	Slow front wiper signal from user switch	P1.5	TIDA-01530	LaunchPad
R_WIPE	Rear wiper on/off signal from user switch	P6.1	TIDA-01530	LaunchPad
R_SPRAY	Rear spray signal from user switch	P3.3	TIDA-01530	LaunchPad
F_SPRAY	Front spray signal from user switch	P3.4	TIDA-01530	LaunchPad
FPARK	Park position signal for front wipers	P3.2	TIDA-01530	LaunchPad
RPARK1	Park position for rear wiper 1	P4.2	TIDA-01530	LaunchPad
RPARK2	Park position for rear wiper 2	P4.1	TIDA-01530	LaunchPad
PUMPOK	Status signal for washer pump drive	P6.2	TIDA-01530	LaunchPad
REAROK	Status signal from rear wiper drive	P4.3	TIDA-01530	LaunchPad
FRONTOK	Status signal from front wiper drive	P8.1	TIDA-01530	LaunchPad
CURRENT_OK	Status signal from system current sense	P1.4	TIDA-01530	LaunchPad
TEMPOK	Status signal from temperature sense	P3.1	TIDA-01530	LaunchPad
IN1F	Command signal to front wiper fast winding	P2.0	LaunchPad	TIDA-01530
IN2F	Command signal to front wiper fast winding	P2.2	LaunchPad	TIDA-01530
IN1S	Command signal to front wiper slow winding	P2.3	LaunchPad	TIDA-01530
IN2S	Command signal to front wiper slow winding	P1.3	LaunchPad	TIDA-01530
IN1R	Command signal to rear wiper 1	P3.7	LaunchPad	TIDA-01530
IN2R	Command signal to rear wiper 2	P4.0	LaunchPad	TIDA-01530
IN1W	Command signal to washer pump	P3.6	LaunchPad	TIDA-01530
IN2W	Command signal to washer pump	P3.5	LaunchPad	TIDA-01530
IREAR_SEL	Selects rear wiper for current sense	P4.3	LaunchPad	TIDA-01530
IMON_LATCH	Sets current monitor to latch or not	P3.0	LaunchPad	TIDA-01530
WAKE	Enables TIDA-01530 board or puts in sleep mode	P2.6	LaunchPad	TIDA-01530
WAKE_SLOW	Enables U4, the slow-speed drive device	P7.4	LaunchPad	TIDA-01530

表 3 lists the current-monitoring signals from the design board to the external LaunchPad microcontroller board. The analog-to-digital converters (ADCs) on the LaunchPad board have a range of 0 V to 3.3 V.

表 3. ADC Settings

SIGNAL	LAUNCHPAD ADC CHANNEL	SCALE FACTOR	COMMENTS
ISLOW	A0	60 mV / A	Front wiper motor current, slow-speed winding
IFAST	A3	60 mV / A	Front wiper motor current, fast-speed winding
IREAR	A4	100 mV / A	Rear wiper motor current, both motors (if applicable)
IPUMP	A12	100 mV / A	Washer pump motor current, either pump direction (front or rear spray)

3.2 Testing and Results

3.2.1 Test Setup

Unless otherwise noted, the following tests were performed at room temperature, with VBATT set to a 12-V nominal supply. Various automotive wiper mechanisms are used as test loads for the front wiper drive, rear wiper drive, and spray pump drive as described in the sections for each type of testing.

3.2.2 Test Results

The test results discussed in the following subsections are representative of the performance with the specific hardware used for testing. When designing, consider the system requirements and expected performance of their specific equipment and test conditions.

3.2.2.1 Power Supply Tests

The power supply tests include testing to measure the variation of the 3.3-V supply when the input voltage (VBATT) varies, testing to measure the variation of the 3.3-V supply when the load current is varied, and measuring the input current when VBATT is negative with respect to GND, which mimics a reverse battery condition.

3.2.2.1.1 3.3-V Supply Line Regulation

表 4 shows that the 3.3-V supply is active and well regulated for input voltages on VBATT in the range of 4 V to 16 V. These measurements are recorded with no external load on the reference design board.

表 4. Line Regulation of 3.3-V Supply

VBATT (V)	3p3V SUPPLY VOLTAGE (V)
0	0
2	0.04
2.46	1.37
3	2.55
3.5	3.029
4	3.318
6	3.3185
12	3.3185
16	3.3185

3.2.2.1.2 3.3-V Supply Load Regulation

The load current on the 3.3-V supply includes the external microcontroller, the INA300-Q1 window comparator, the TMP302-Q1 temperature switch, and various pull-up resistors on the logic signals throughout the TIDA-01530 board. 表 5 shows the effect of varying the external load current (through J4-2) on the 3.3-V supply, measured at TP5. For external load currents up to 66 mA, the regulation is within 10 mV of the no-load measurement.

表 5. Load Regulation of 3.3-V Supply

EXTERNAL LOAD CURRENT (mA)	3p3V SUPPLY VOLTAGE (V)
0	3.3146
11.0	3.3134
16.6	3.3130
36.8	3.3111
55.2	3.3096
66.1	3.3074

3.2.2.1.3 Quiescent Power Consumption

With none of the motors being driven, the quiescent power consumption of the design depends on the state of the board and associated microcontroller board. 表 6 summarizes quiescent power consumption with a nominal 12-V automotive battery system applied to VBATT.

表 6. Quiescent Power Consumption Measurements

CONDITIONS	MEASURED INPUT CURRENT	POWER CONSUMPTION
TIDA-01530 board only, WAKE and WAKE_SLOW logic low, LED disconnected, parking sensor disconnected	64 μ A	0.768 mW
TIDA-01530 board only, WAKE and WAKE_SLOW logic low, LED disconnected, parking sensor connected	100 μ A	1.2 mW
TIDA-01530 board only, WAKE and WAKE_SLOW logic low, LED connected	7 mA	84 mW
TIDA-01530 board with MSP430F5529 LaunchPad running test program, LED disconnected	56 mA	672 mW
TIDA-01530 board with MSP430F5529 LaunchPad running test program, LED connected, park sensor connected	62 mA	744 mW

3.2.2.1.4 Reverse Battery Protection

図 19 shows the input current under conditions of negative voltages applied to VBATT (J1-2) with respect to GND (J1-1). For applied voltages more negative than -1 V, the current increases linearly, primarily due to the resistor R7 shown in 図 11.



図 19. Input Current vs Applied Negative Voltage at VBATT

3.2.2.2 Front Wiper Tests

図 20 shows the hardware used as a representative load for the front wiper drive circuits. This mechanism fits Cadillac™ XTS models starting in 2013 through 2017. A single brushed DC motor drives both front wipers through a set of speed reduction (torque increase) gears and bar linkages. The linkages convert the continuous unidirectional rotary motion produced by the motor to a reciprocating motion on the wiper blade axes.

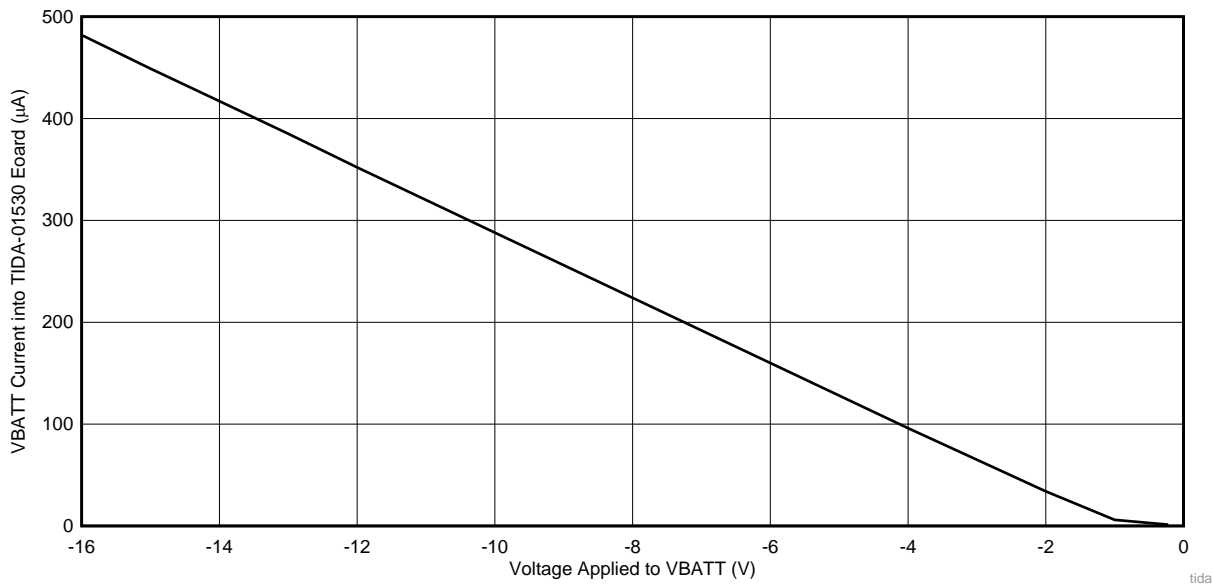

図 20. Front Wiper Hardware

3.2.2.2.1 Front Wiper Speed versus Voltage Tests

図 21 shows the relationship between applied input voltage VBATT and the speed of the wiper mechanism with the slow speed winding actively driven by the reference design. The speed of the wiper mechanism increases linearly as the applied VBATT voltage is increased. The measurements are recorded with no wiper arm attached, so this plot represents results with no load (other than the friction of the gear train and mechanism) conditions.



図 21. Front Wiper Slow Winding Speed vs Battery Voltage

図 22 shows the relationship between applied input voltage VBATT and the speed of the wiper mechanism with the fast speed winding actively driven by the reference design. The speed of the wiper mechanism increases more or less linearly as the applied VBATT voltage is increased. The measurements are recorded with no wiper arm attached, so this plot represents results with no load (other than the friction of the gear train and mechanism) conditions.

For any applied voltage VBATT, the measured speed of the fast winding is about 67% faster than the speed of the slow winding with the same VBATT applied.

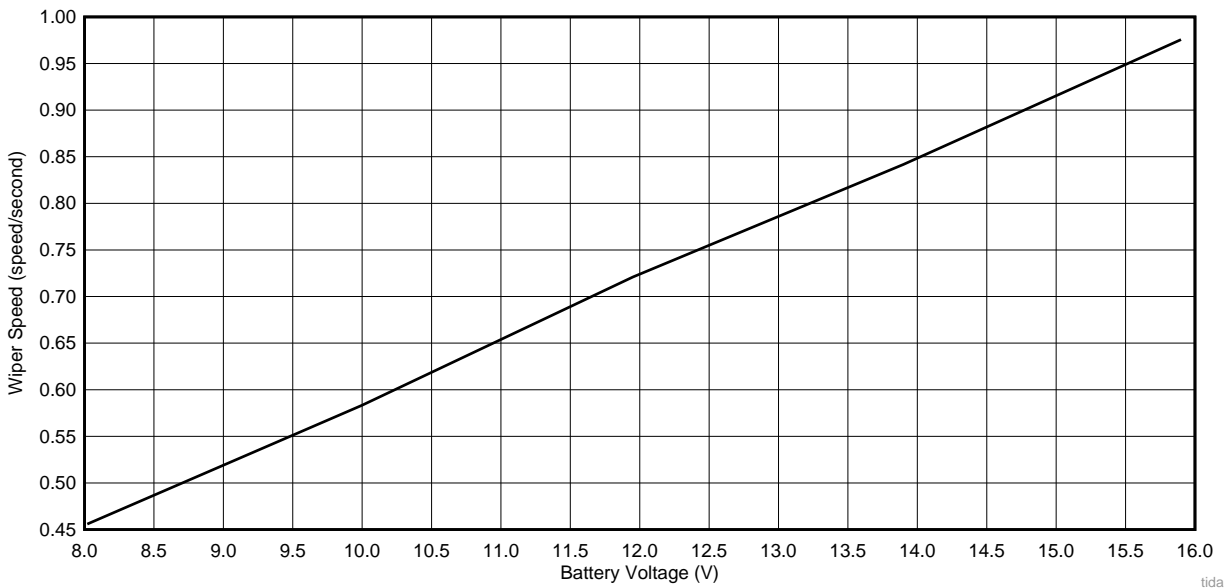

図 22. Front Wiper Fast Winding Speed vs Battery Voltage

3.2.2.2 Front Motor Current Tests

Whether slow winding or fast winding, the current through the front wiper motor flows through resistor R18. When the slow winding is active, the current sense amplifier in U4 amplifies the voltage across R18 and outputs the signal ISLOW to the microcontroller interface with a scale factor of 60 mV/A. When the fast winding is active, the current sense amplifier in U6 amplifies the voltage across R18 and outputs the signal IFAST to the microcontroller interface with a scale factor of 60 mV/A.

In the following oscilloscope plots, the motor current signal is on Channel 1, showing the current profile when the front wiper motor operates.

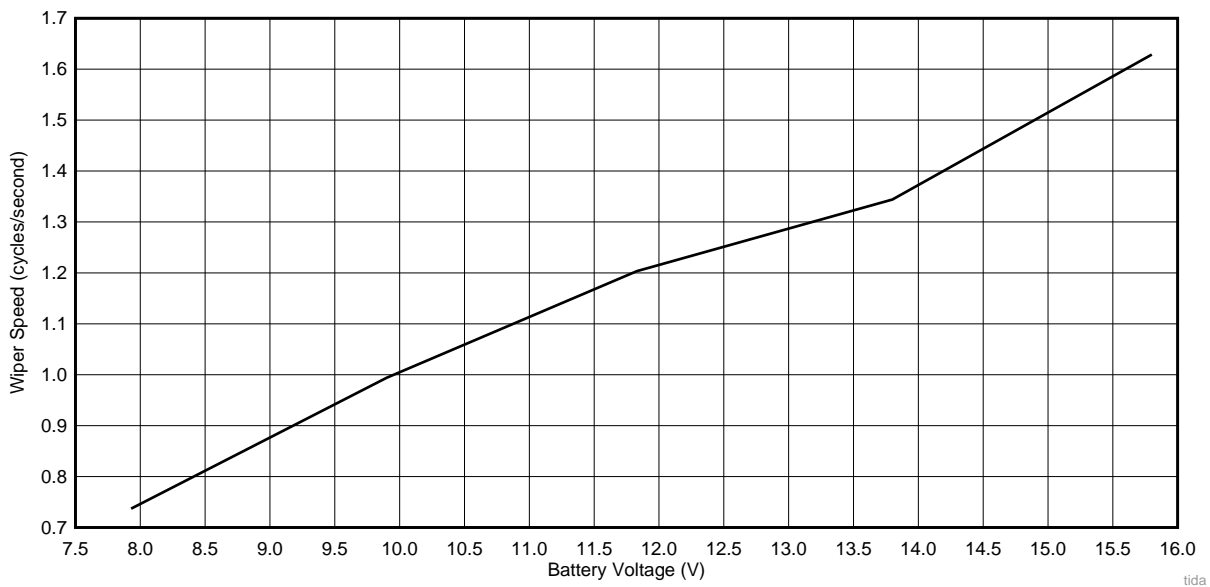
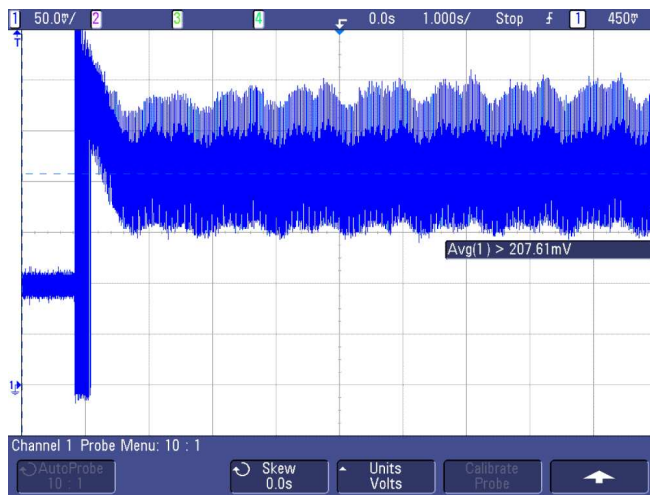

23. Front Wiper Motor Current (IFAST) During Motor Start

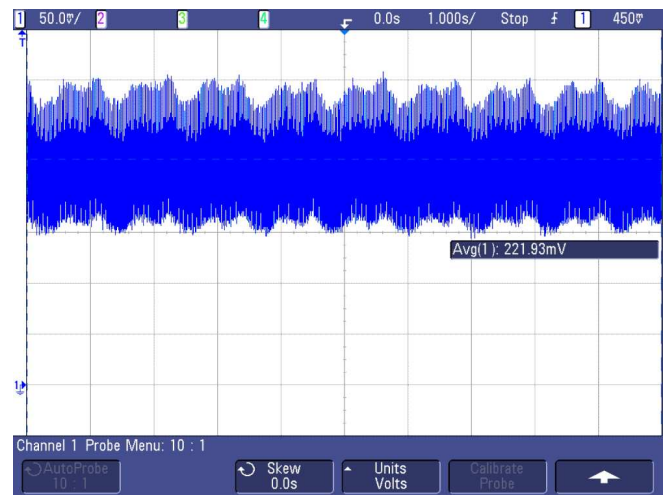

24. Front Wiper Motor Current (IFAST) During Wiper Operation

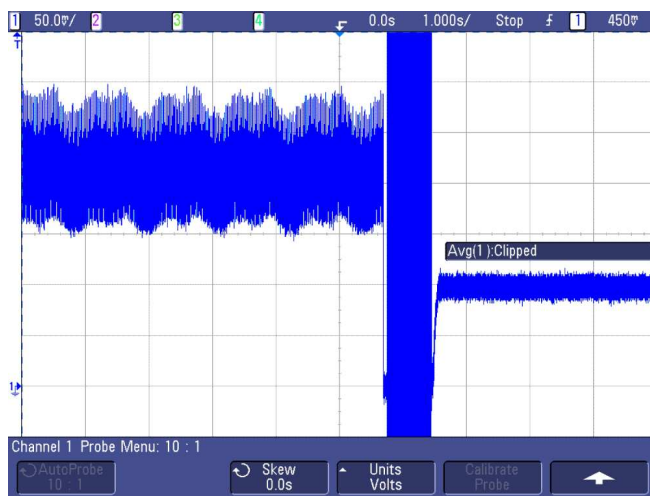

25. Front Wiper Motor Current (IFAST) During Motor Stop

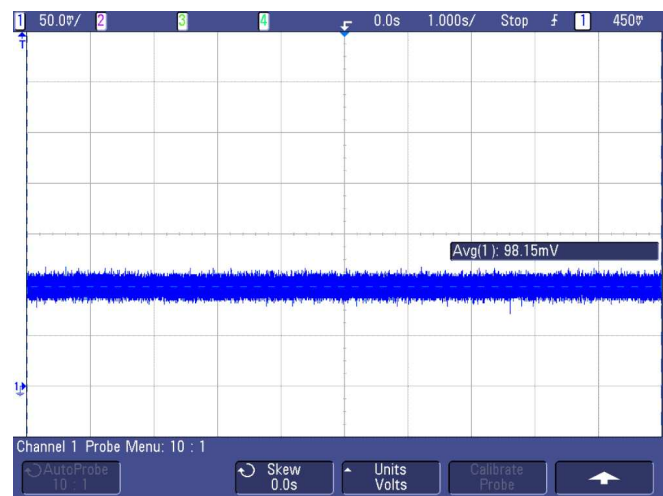

26. Front Wiper Motor Current (IFAST) During Motor Off

With both a slow-speed and a fast-speed winding in the same motor assembly, a voltage is generated on the unused winding whenever the motor is turning. When the slow winding is active, the voltage generated on the fast winding is less than the supply voltage, as shown in [Figure 27](#). In this case, the generated voltage is blocked from VMOTOR and from GND because the drive transistors Q4 and Q6 are turned off. Because the generated voltage is less than VMOTOR, it does not exceed the ratings for the SH pin of the DRV8702D-Q1.

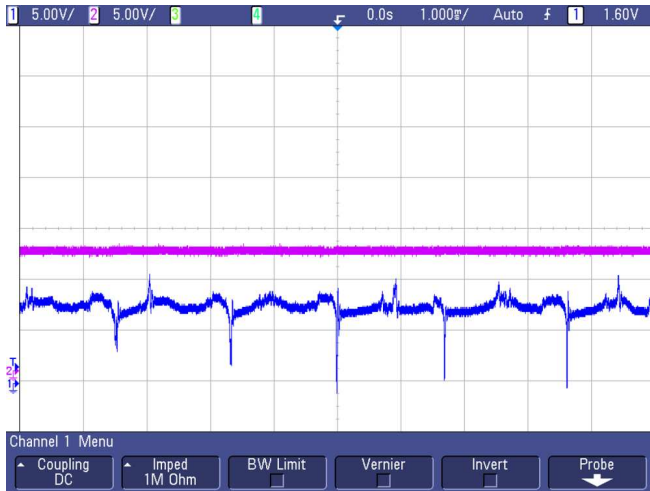

Figure 27. Measure Fast Winding (Channel 1) While Driving Slow Winding (Channel 2)

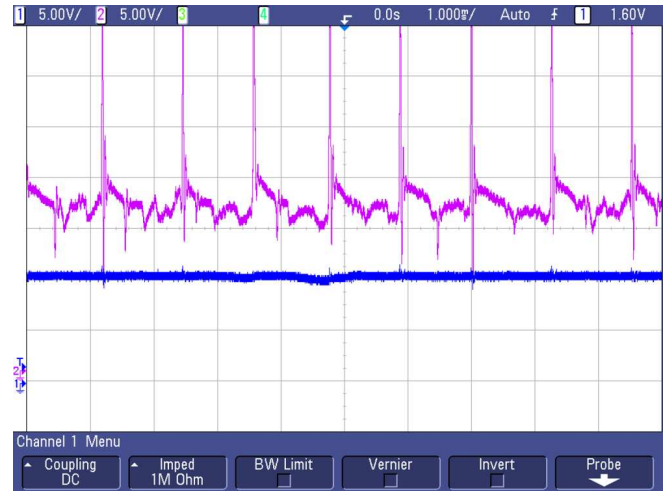

Figure 28. Measuring Slow Winding (Channel 2) While Driving Fast Winding (Channel 1)

When the fast winding is active, the voltage generated on the slow winding exceeds VMOTOR, as shown in [Figure 28](#). This generated voltage is blocked from the VMOTOR supply and from the slow winding DRV8702D-Q1 as described in [2.4.1.2](#). This design uses FETs with 60-V VDS specifications; if the slow winding generates voltages higher than 60V, then FETs with higher standoff capability should be selected.

3.2.2.2.3 Front Wiper Start-up

Channel 1 is the active low signal from the slow speed switch of the front wiper (SLOW, J5-6). Channel 2 is the SLOWOK signal from U4-10 (active low nFAULT), which indicates with a high logic level that the DRV8702D-Q1 has not detected any fault conditions. Channel 3 is the amplified motor current measurement ISLOW with a scale factor of 60 mV/A. Channel 4 is the slow winding motor voltage on J2-2.

[Figure 29](#) shows the initial time after the front wiper is turned on using the slow winding. About 100 µs after the SLOW switch goes low, the current on Channel 3 begins to ramp as VMOTOR is applied to the slow winding through the high-side FETs. The slope of the current ramp is determined by the impedance of the motor winding with a time constant of L divided by R, where L is the inductance of the winding and R is the resistance of the winding.

After about 1.5 ms, the motor current has ramped to a measured level of about 650 mV above the 100-mV quiescent point. This corresponds to a motor current of about 11 A, similar to the value calculated in [2.4.1.3](#). At this point, the DRV8702D-Q1 begins to regulate the motor current by pulse width modulation (PWM) of the gate drive signals to the high-side FETs. The current then begins to reduce until the current level reaches the point where PWM is discontinued. The motor current then increases until the 11-A regulation point is reached, and the cycle repeats.



図 29. Slow Winding Start Sequence

図 30 shows a longer time view of the front wiper start-up sequence. As the motor begins to turn, the back EMF increases, reducing the voltage across the winding impedance. This results in the current ramping at a slower rate, which is indicated by the increasing interval between the periods of PWM. After about 25 ms, the rotation of the wiper motor is such that the maximum current no longer exceeds the 11-A regulation point, and no further PWM occurs. As the motor continues to increase in speed, the motor current is reduced to a steady-state value of a little more than 1 A, as indicated by the ISLOW value of about 150 mV.

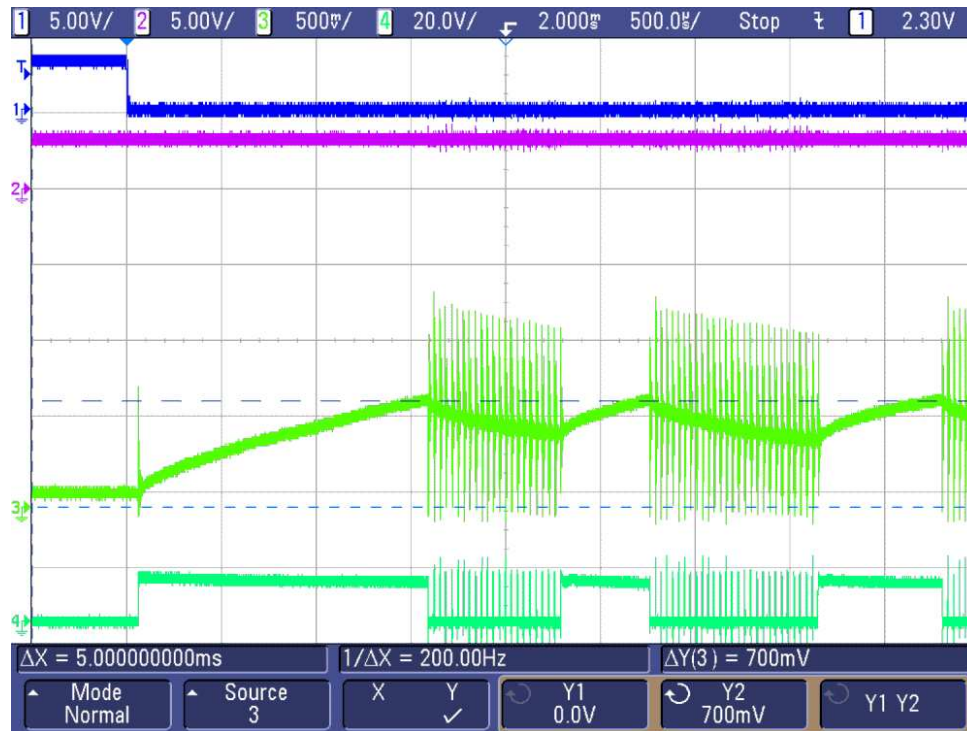
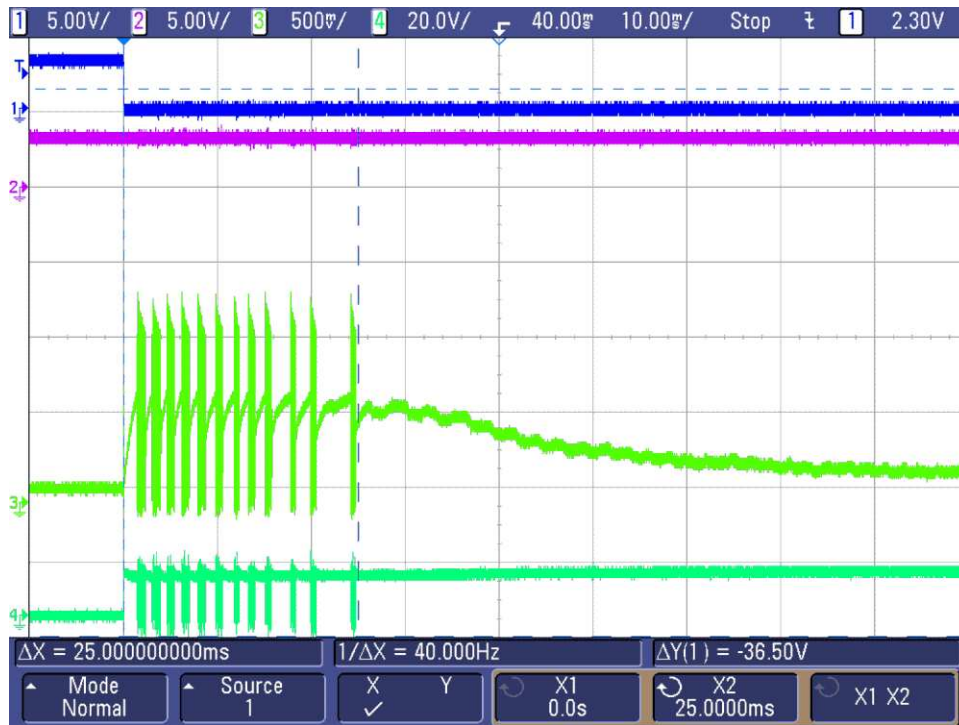

☒ 30. Caption Needed

☒ 31 shows a detail view of the front wiper signals during the PWM of the slow winding current. As described in the DRV8702D-Q1 data sheet, the PWM off time is fixed at 25 μ s, while the on-time is variable. In this instance, the period of the PWM is about 30 μ s.

☒ 32 includes a measurement of the ringing frequency during the PWM of the slow winding current. For this example, the frequency of ringing is measured as about 240 kHz.

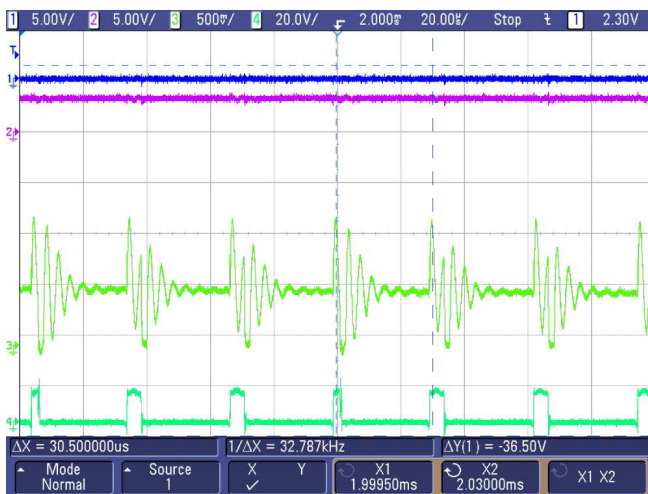

☒ 31. Detail of Front Wiper Start With Measurement of PWM Period

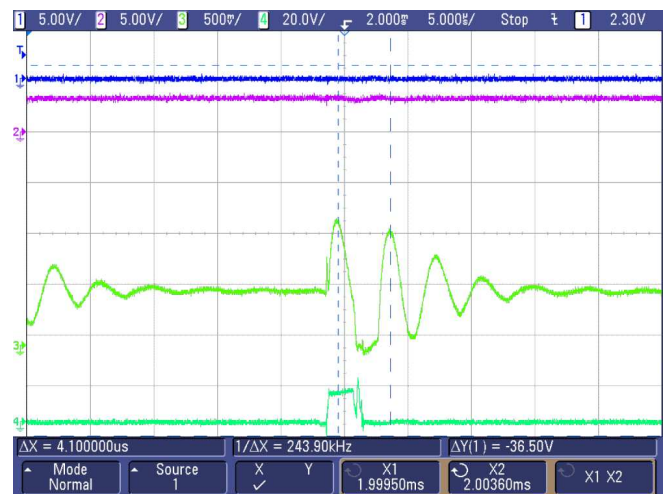

☒ 32. Detail of Front Wiper Motor Start With Measurement of Current Ringing

3.2.2.3 Rear Wiper Tests

Figure 33 shows the hardware used as a representative load for the rear wiper drive circuit. A brushed DC motor drives the rear wiper through a set of speed reduction (torque increase) gears and linkages. The unidirectional rotary motion produced by the motor is converted to a reciprocating motion on the rear wiper axis. This hardware was purchased as used equipment from an online vendor.



Figure 33. Rear Wiper Hardware

Figure 34 shows a typical single-speed wiper motor for the rear wiper. With the windings exposed, the six pole pairs are visible.



Figure 34. Detail of Typical Single-Speed Wiper Motor With Exposed Windings

3.2.2.3.1 Rear Wiper Speed versus Voltage Tests

Figure 35 shows the relationship between applied input voltage VBATT and the speed of the wiper mechanism with the rear wiper winding actively driven by the reference design board. The speed of the wiper mechanism increases more or less linearly as the applied VBATT voltage is increased. The measurements are recorded with no wiper arm attached, so this plot represents results with no load conditions (other than the friction of the gear train and mechanism).

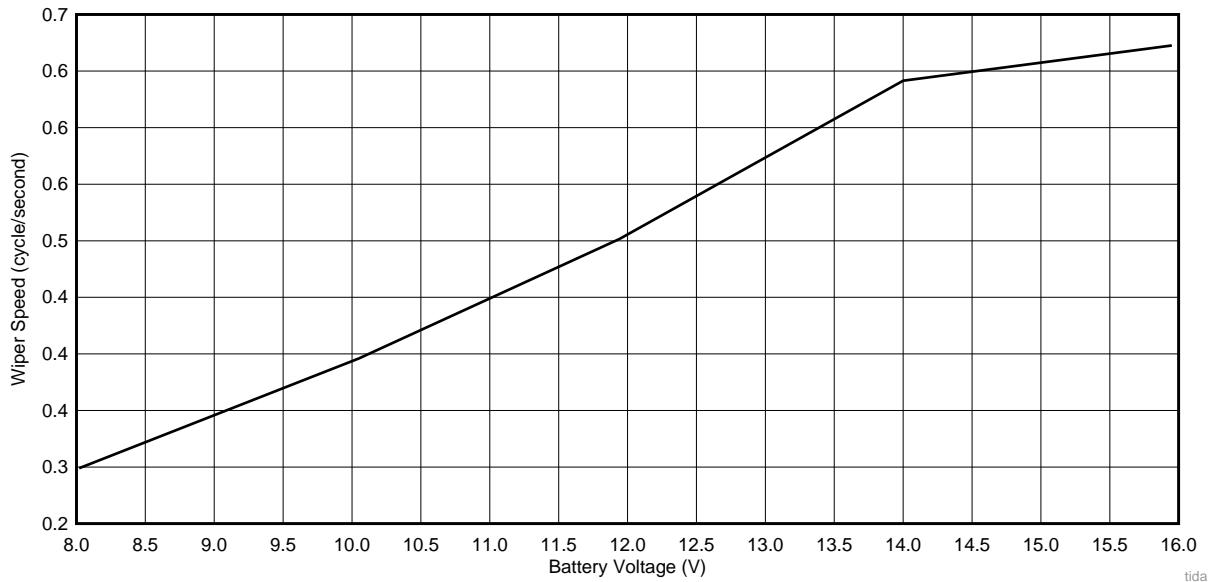

Figure 35. Rear Wiper Speed vs Battery Voltage

3.2.2.3.2 Rear Wiper Current Measurements

Figure 36 shows the rear wiper motor current IREAR during the start of the rear wiper operation. Before the rear wiper motor is activated, the voltage on IREAR is 72.5 mV, corresponding to about 3.7 mV of input offset on the current sense amplifier. When the rear wiper motor is activated, there is an initial current transient, due to the high current when there is no back EMF from the motor. As the motor begins to turn, the current is reduced, and the voltage on IREAR is about 100 mV above the zero-current value after 0.5 s.

Figure 37 shows IREAR during steady-state operation of the rear wiper. The cursor is about 150 mV, corresponding to an average motor current of about 1.3 A. The period of the current is slightly over 2 s, which agrees with the rear wiper speed measurement at VBATT = 12 V shown in Figure 35.



図 36. Rear Wiper Motor Current During Start



図 37. Rear Wiper Motor Current While Running

図 38 shows a detail of the rear wiper current, with a measurement of the rotation of the motor highlighted. With a motor rotation period of 22.4 ms, the motor is rotating at a speed of 44.6 Hz or about 2600 RPM.

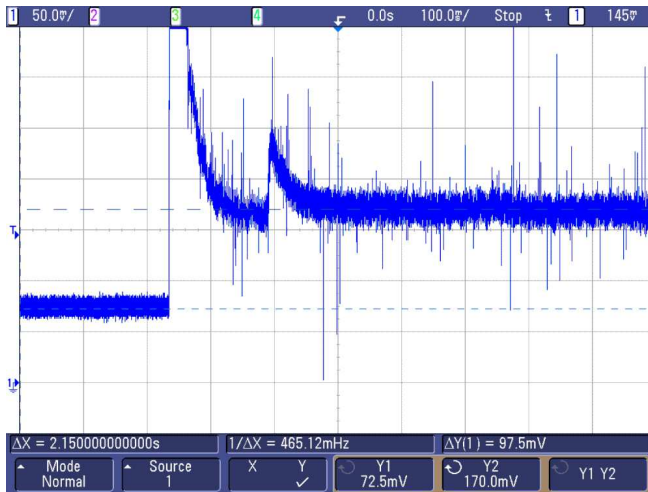
図 39 shows a further detail of the rear wiper motor current, with a measurement of a single cycle of the motor poles highlighted. There are 12 cycles of motor pole current within each cycle of motor rotation, indicating six motor pole pairs in one mechanical motor rotation.

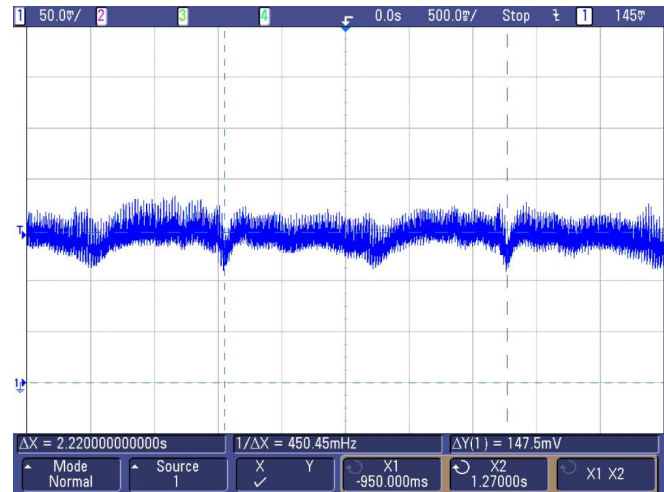

図 38. Rear Wiper Current Measuring One Cycle of Motor Rotation



図 39. Rear Wiper Motor Current Measuring One Cycle of Pole Rotation

3.2.2.4 Washer Spray Pump Tests

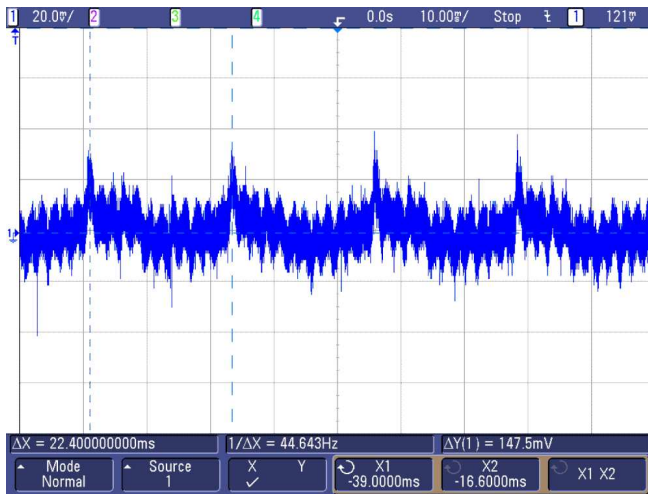
図 40 shows the hardware used as a representative load for the pump, which sprays fluid to wash the windshields. This type of pump sprays either the front or rear windshields, depending on the polarity of drive signal supplied to the motor. When the motor polarity is positive, the front windshield is sprayed. When the motor polarity is negative, the rear wiper is sprayed. This feature allows the automobile owner to maintain a single tank of windshield washer fluid for both front and rear windshields. A brushed DC motor drives the pump in either direction according to the motor polarity. This hardware was purchased from an online vendor.

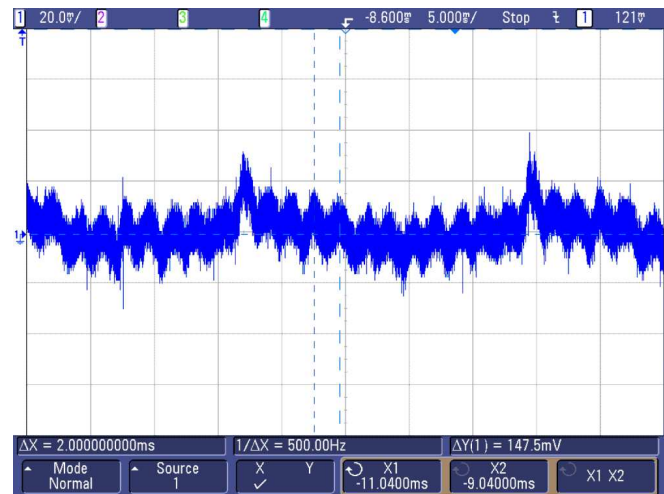

図 40. Spray Washer Pump Hardware

3.2.2.4.1 Spray Pump Measurements for Various Nozzle Conditions

The electrical performance of the spray pump motor depends on the medium being pumped (typically water mixed with washer fluid) and the number of nozzles through which the fluid is sprayed. 表 7 shows the current and pump motor voltage under various conditions for the pump in air, pumping water with open tubes, and pumping water with nozzles installed in the tubes.

表 7. Washer Spray Pump Measurements With VBATT = 12 V

CONDITIONS	IN1W	SUPPLY CURRENT (A)	PUMP VOLTAGE (V)	PUMP POWER (W)
Pump in air (no water flow)	HIGH	0.80	11.912	9.53
	LOW	0.74	11.924	8.82
Pump in water, 1 nozzle per direction	HIGH	4.14	11.536	47.8
	LOW	4.02	11.561	46.5
Pump in water, no nozzles (open tubes)	HIGH	4.79	11.46	54.9
	LOW	4.82	11.48	55.3

図 41 shows the power dissipated by the spray pump motor during the various conditions listed in 表 7. The power dissipation is similar for the two directions of the pump, either supplying the front wipers or the rear wipers with spray.



図 41. Washer Spray Pump Power Under Various Conditions With VBATT = 12 V

表 8 shows the effect of varying the applied battery voltage (VBATT) on the spray pump performance.

表 8. Washer Spray Pump Measurements With Single Nozzle per Direction

BATTERY VOLTAGE (V)	IN1W	SUPPLY CURRENT (A)	PUMP VOLTAGE (V)	PUMP POWER (W)
6	HIGH	1.53	5.81	8.9
	LOW	1.63	5.81	9.5
12	HIGH	4.14	11.536	47.8
	LOW	4.02	11.561	46.5
18	HIGH	6.1	17.3	102
	LOW	6.3	17.29	109

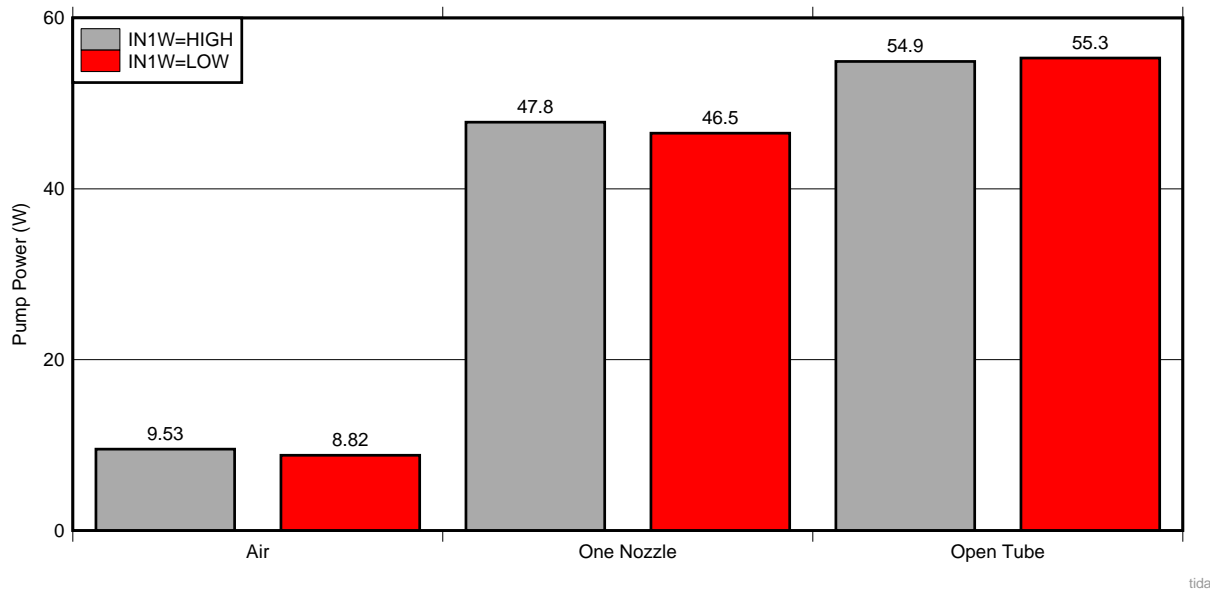
3.2.2.4.2 Pump Motor Current Measurements

図 42 and 図 43 show the spray pump motor current signal IPUMP when the spray pump is activated for the front and rear sprayers, respectively. 図 42 shows that after the initial transient, the voltage on the IPUMP signal is 400 mV, which is 340 mV above the no-current level of 60 mV. With a scale factor of 100 mV/A, this value indicates the pump motor current is about 3.4 A when the front spray direction is selected. For the rear spray direction, the value of IPUMP of 375 mV shown in 図 43 corresponds to a pump motor current of 3.15 A.



図 42. Spray Pump Motor Current, Starting Front Spray



図 43. Spray Pump Motor Current, Starting Rear Spray

3.2.2.4.3 Spray Pump Flow Rate Measurements

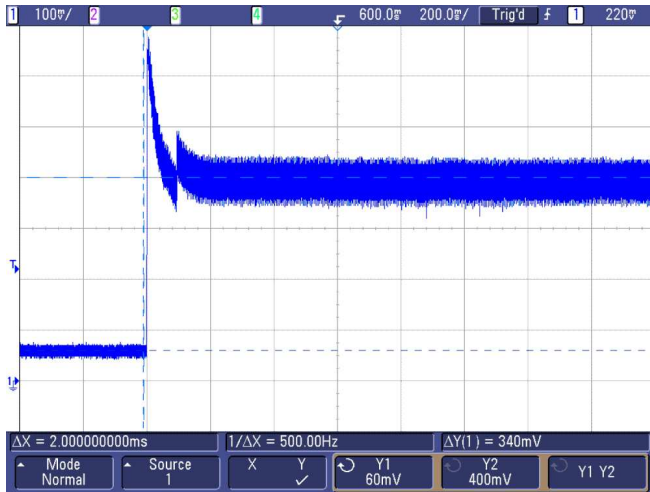
図 44 shows the relationship between applied input voltage at VBATT and the flow rate from the spray pump. For applied voltages less than 6 V, the pump did not generate sufficient pressure to draw water from the reservoir to the spray nozzle. For voltages above 6 V, the spray flow rate increases to about 25 mL/s at VBATT = 12 V.



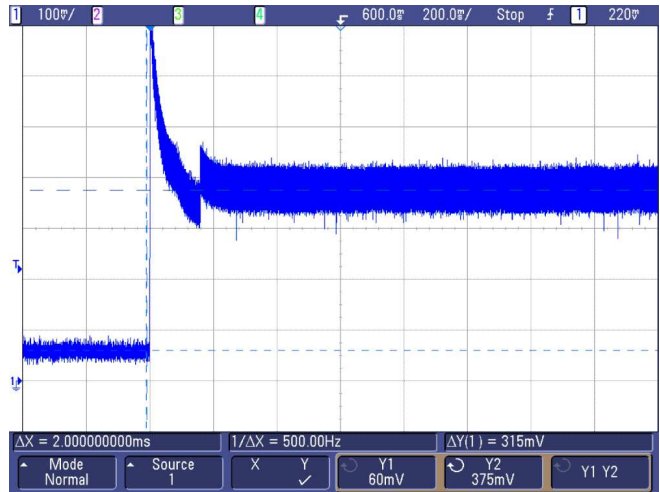



図 44. Spray Pump Flow Rate Measurements vs Applied Voltage

3.2.2.5 Infrared (IR) Imaging

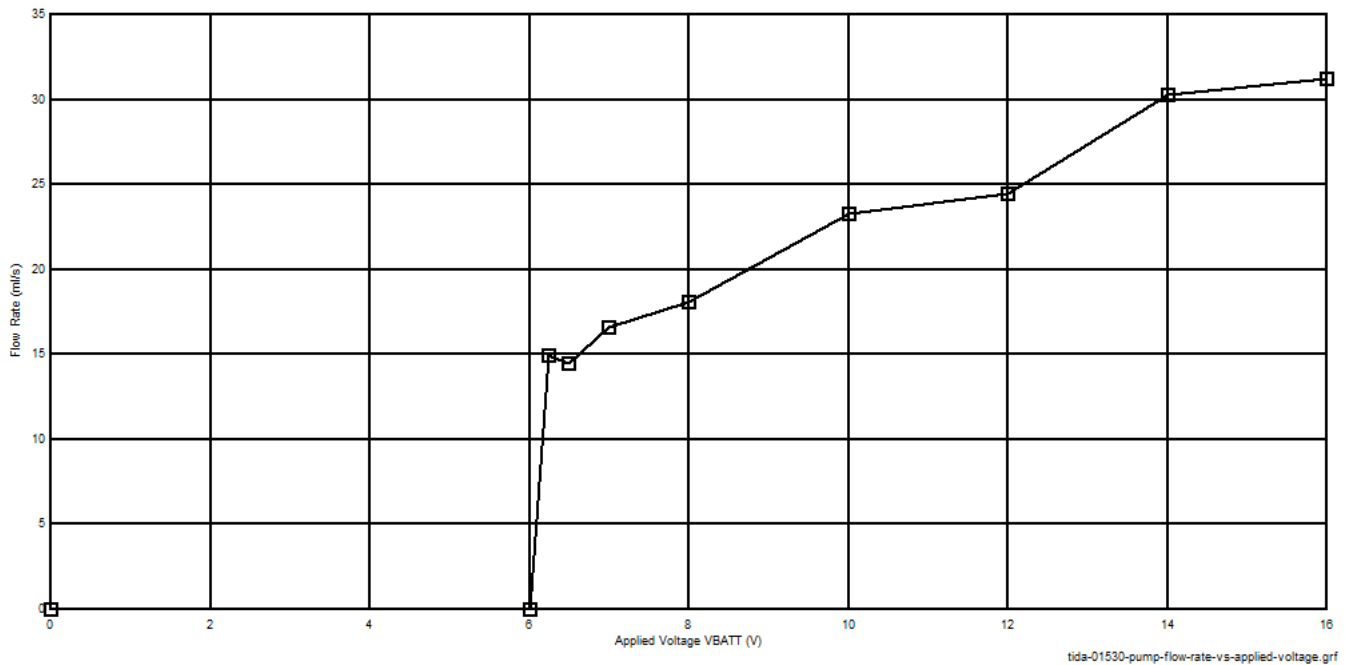
The temperature of the components on the reference design board can be measured using an infrared camera.  45 through  48 show the temperature profile of the board under various operating conditions. In each case, the board was operating in open air with a 12-V nominal supply at normal room temperature. The indicated temperature scale is in degrees Centigrade.

 45 shows the board temperature profile with 12-V VBATT applied, but none of the motor operating. The maximum temperature is about 9°C above the background temperature. The LaunchPad board shows temperatures about as high as the DRV8702-Q1 devices on the design board. The other hot spot is the 3.3-V linear regulator U4, which is dissipating about 500 mW (60 mA × 8.7 V) as it generates the 3.3-V supply for the onboard components and for the LaunchPad board.

 46 shows the board temperature with the front wiper motor operating in the slow mode. Compared to the previous image, the DRV8702D-Q1 (U4) and slow-winding drive FETs are somewhat hotter than with no motors operating. The maximum temperature detected has increased to 33.3°C.

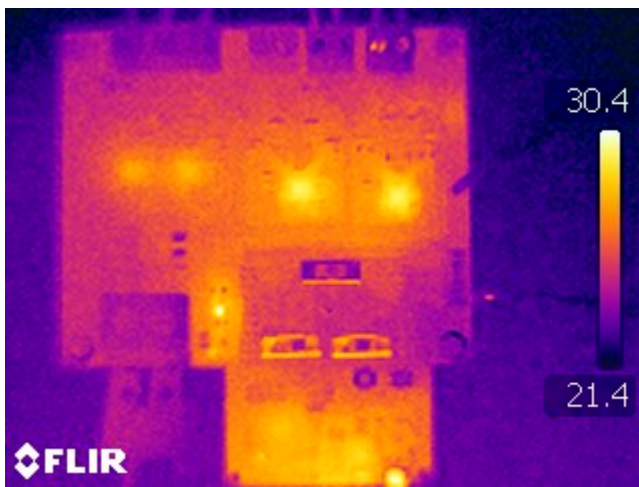

 45. Infrared Image With No Motors Active

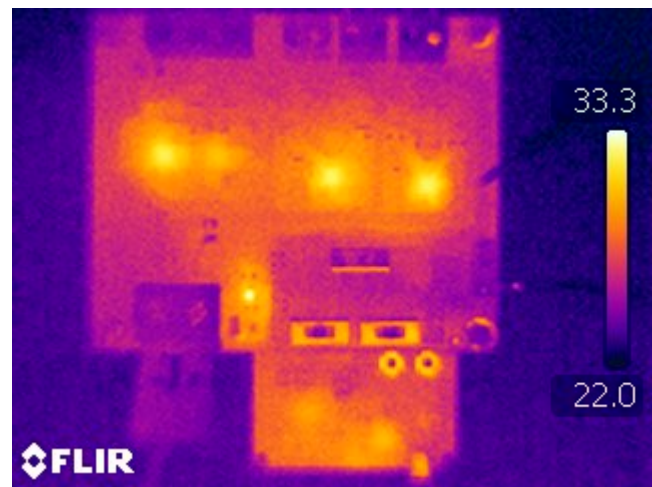

 46. Infrared Image With Front Wiper Motor Active

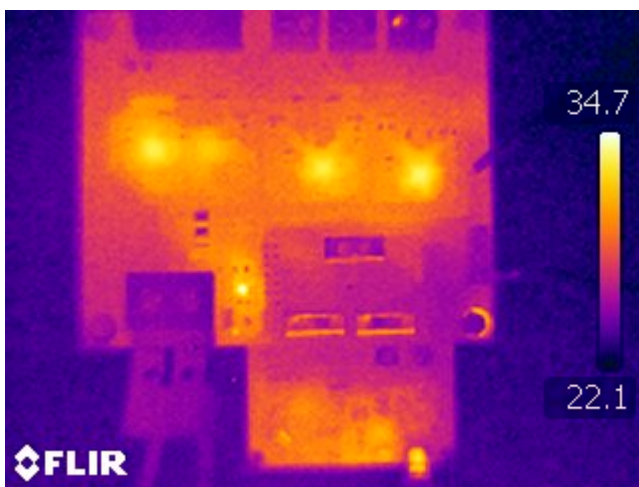

 47. Infrared Image With Front and Rear Wiper Motors Active

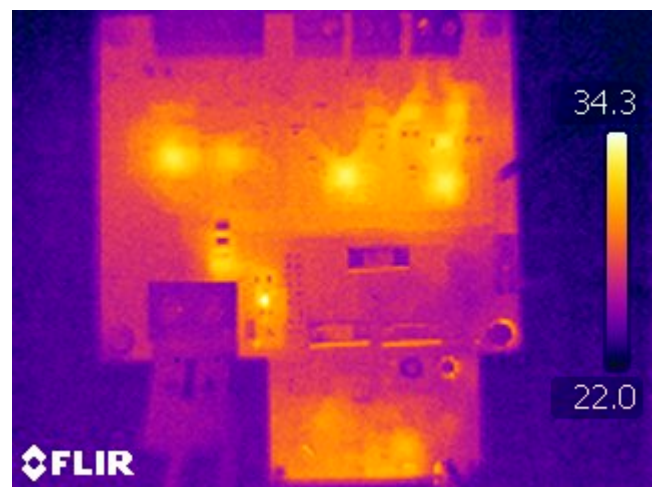

 48. Infrared Image With Pump Motor Active

☒ 47 shows the thermal profile with both the front wiper motor and the rear wiper motor operating. ☒ 48 shows the thermal profile with only the washer pump motor operating. The washer pump motor drive FETs and even the shape of the top-side traces to the spray pump connector are visible.

4 Design Files

4.1 Schematics

To download the schematics, see the design files at [TIDA-01530](#).

4.2 Bill of Materials

To download the bill of materials (BOM), see the design files at [TIDA-01530](#).

4.3 PCB Layout Recommendations

4.3.1 Layout Prints

To download the layer plots, see the design files at [TIDA-01530](#).

4.3.2 Board Layer Stack and Components

☒ 49 shows the layer stackup for the reference design board. The top and bottom side signal layers are 2-oz copper to carry the high currents expected during motor operation. The total thickness is a standard 62 mils.

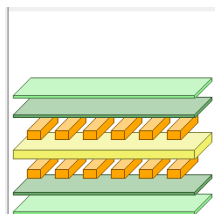

Layer Name	Type	Material	Thickness (mil)	Dielectric Material	Dielectric Constant
Top Overlay	Overlay				
Top Solder	Solder Mask/Coverlay	Surface Material	0.4	Solder Resist	3.5
Top Layer	Signal	Copper	2.8		
Dielectric1	Dielectric	Core	56.4	FR-4	4.8
Bottom Layer	Signal	Copper	2.8		
Bottom Solder	Solder Mask/Coverlay	Surface Material	0.4	Solder Resist	3.5
Bottom Overlay	Overlay				

☒ 49. Board Layer Stackup

To reduce manufacturing costs and provide flexibility in board mounting, all the components for the design board are on the top side. The associated LaunchPad can be mounted on either the top side or underneath. ☒ 50 shows the bottom side of the reference design board. Restricting component placement to the top side of the board also allows mounting a heat sink to the bottom side of the board, if needed for thermal dissipation at high temperatures.



図 50. Board Bottom View

4.3.3 High-Current Traces

Depending on the motor sizes, number of motors operating at one time, and wiper torque requirements, the current through the board traces can be relatively high (up to 30 A). The high-current traces are wide to provide current-carrying capacity, and reduce power losses due to Ohmic heating.

図 51 shows the trace for the VBATT signal, which connects incoming voltage from the battery system to Q1, the reverse-polarity protection FET.

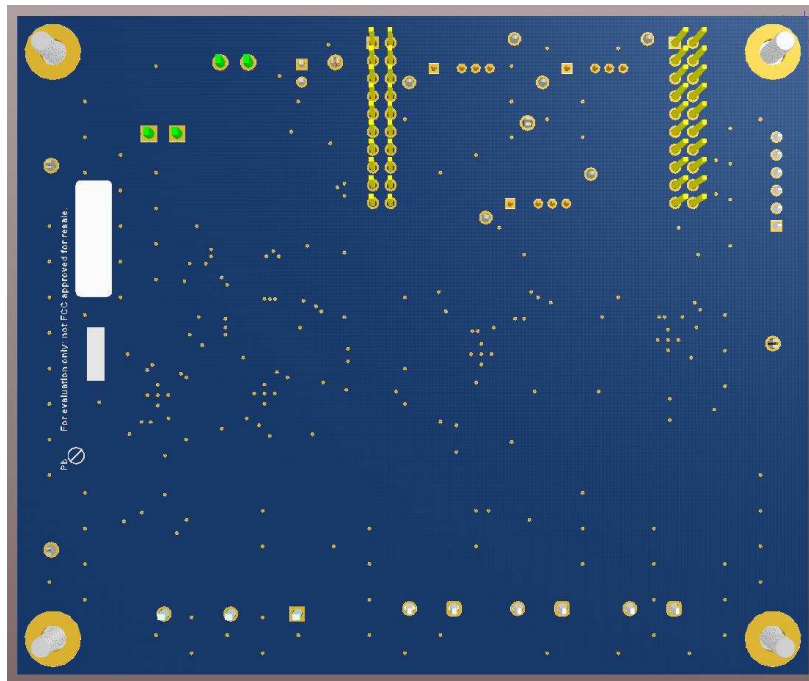

図 51. VBATT Trace

図 52 shows the trace that distributes the motor high-side supply VMOTOR to the various drive FETs. After passing through the system current sense resistor R1, the VMOTOR supply runs to each high-side FET through a 100-mil trace, with a main supply trace with width 160 mils running the length of the board.

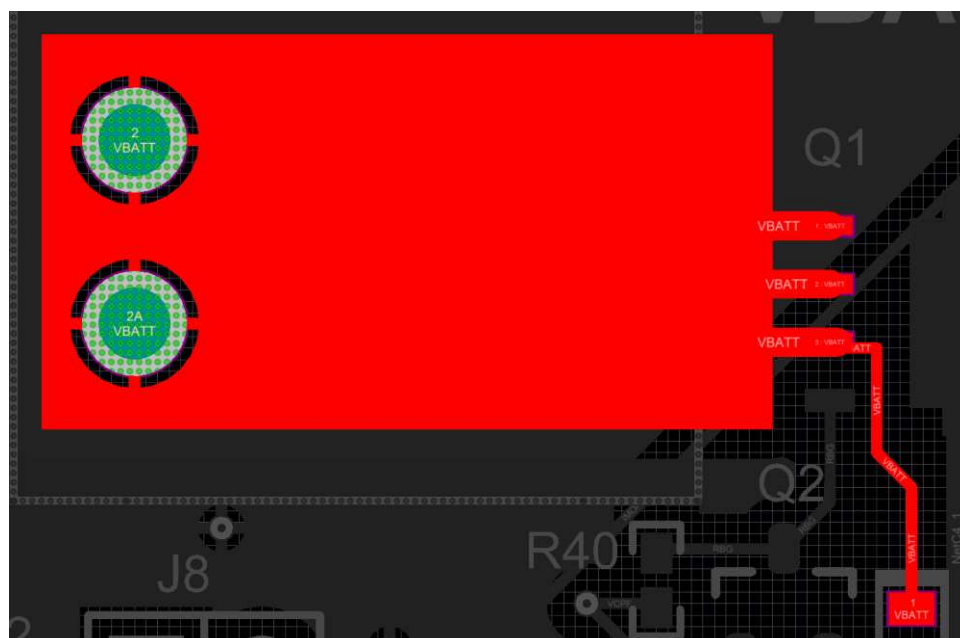

図 52. VMOTOR Trace

図 53 shows the FAST_WINDING trace as an example of the circuit board trace, which connects the drive FETs to the motor winding—in this case, for the front wiper fast speed winding.

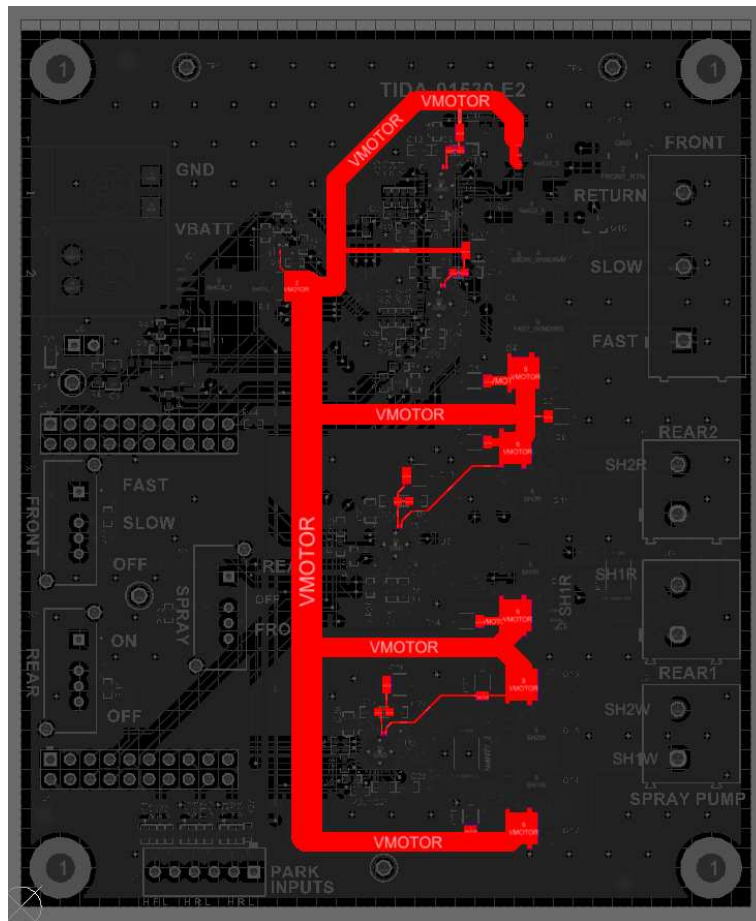

図 53. Fast Winding Trace

4.4 Altium Project

To download the Altium project files, see the design files at [TIDA-01530](#).

4.5 Gerber Files

To download the Gerber files, see the design files at [TIDA-01530](#).

4.6 Assembly Drawings

To download the assembly drawings, see the design files at [TIDA-01530](#).

5 Related Documentation

1. Texas Instruments, [DRV8702D-Q1 Automotive Half-Bridge Driver Data Sheet](#)
2. Texas Instruments, [DRV8702-Q1 Automotive Brushed DC Motor Gate Driver Data Sheet](#)
3. Texas Instruments, [INA300-Q1 Automotive-Grade, Overcurrent-Protection, Current-Sense Comparator Data Sheet](#)
4. Texas Instruments, [TPS7B69xx-Q1 High-Voltage Ultra-Low \$I_Q\$ Low-Dropout Regulator](#)
5. Texas Instruments, [TMP302-Q1, Automotive Grade, Low-Power, Easy-to-Use, Temperature Switch in MicroPackage Data Sheet](#)
6. Texas Instruments, [LaunchPad Development Kit \(MSP-EXP430F5529LP\) User's Guide](#)

5.1 商標

E2E, BoosterPack, LaunchPad, Code Composer Studio are trademarks of Texas Instruments.

Cadillac is a trademark of GM, its subsidiaries, affiliates or licensors.

すべての商標および登録商標はそれぞれの所有者に帰属します。

6 About the Author

CLARK KINNAIRD is a systems applications engineer at Texas Instruments. As a member of the Automotive Systems Engineering team, Clark works on various types of end-equipment, especially in the field of body electronics, creating reference designs for automotive manufacturers. Clark earned his bachelor of science and master of science in engineering from the University of Florida, and his Ph.D. in electrical engineering from Southern Methodist University.

TIの設計情報およびリソースに関する重要な注意事項

Texas Instruments Incorporated ("TI")の技術、アプリケーションその他設計に関する助言、サービスまたは情報は、TI製品を組み込んだアプリケーションを開発する設計者に役立つことを目的として提供するものです。これにはリファレンス設計や、評価モジュールに関係する資料が含まれますが、これらに限られません。以下、これらを総称して「TIリソース」と呼びます。いかなる方法であっても、TIリソースのいずれかをダウンロード、アクセス、または使用した場合、お客様(個人、または会社を代表している場合にはお客様の会社)は、これらのリソースをここに記載された目的にのみ使用し、この注意事項の条項に従うことに合意したものとします。

TIによるTIリソースの提供は、TI製品に対する該当の発行済み保証事項または免責事項を拡張またはいかなる形でも変更するものではなく、これらのTIリソースを提供することによって、TIにはいかなる追加義務も責任も発生しないものとします。TIは、自社のTIリソースに訂正、拡張、改良、およびその他の変更を加える権利を留保します。

お客様は、自らのアプリケーションの設計において、ご自身が独自に分析、評価、判断を行う責任がお客様にあり、お客様のアプリケーション(および、お客様のアプリケーションに使用されるすべてのTI製品)の安全性、および該当するすべての規制、法、その他適用される要件への遵守を保証するすべての責任をお客様のみが負うことを理解し、合意するものとします。お客様は、自身のアプリケーションに関して、(1) 故障による危険な結果を予測し、(2) 障害とその結果を監視し、および、(3) 損害を引き起こす障害の可能性を減らし、適切な対策を行う目的での、安全策を開発し実装するために必要な、すべての技術を保持していることを表明するものとします。お客様は、TI製品を含むアプリケーションを使用または配布する前に、それらのアプリケーション、およびアプリケーションに使用されているTI製品の機能性を完全にテストすることに合意するものとします。TIは、特定のTIリソース用に発行されたドキュメントで明示的に記載されているもの以外のテストを実行していません。

お客様は、個別のTIリソースにつき、当該TIリソースに記載されているTI製品を含むアプリケーションの開発に関連する目的でのみ、使用、コピー、変更することが許可されています。明示的または黙示的を問わず、禁反言の法理その他どのような理由でも、他のTIの知的所有権に対するその他のライセンスは付与されません。また、TIまたは他のいかなる第三者のテクノロジーまたは知的所有権についても、いかなるライセンスも付与されるものではありません。付与されないものには、TI製品またはサービスが使用される組み合わせ、機械、プロセスに関連する特許権、著作権、回路配置利用権、その他の知的所有権が含まれますが、これらに限られません。第三者の製品やサービスに関する、またはそれらを参照する情報は、そのような製品またはサービスを利用するライセンスを構成するものではなく、それらに対する保証または推奨を意味するものでもありません。TIリソースを使用するため、第三者の特許または他の知的所有権に基づく第三者からのライセンス、もしくは、TIの特許または他の知的所有権に基づくTIからのライセンスが必要な場合があります。

TIのリソースは、それに含まれるあらゆる欠陥も含めて、「現状のまま」提供されます。TIは、TIリソースまたはその仕様に関して、明示的か暗黙的にかかわらず、他のいかなる保証または表明も行いません。これには、正確性または完全性、権原、続発性の障害に関する保証、および商品性、特定目的への適合性、第三者の知的所有権の非侵害に対する黙示的保証が含まれますが、これらに限られません。

TIは、いかなる苦情に対しても、お客様への弁済または補償を行う義務はなく、行わないものとします。これには、任意の製品の組み合わせに関連する、またはそれらに基づく侵害の請求も含まれますが、これらに限られず、またその事実についてTIリソースまたは他の場所に記載されているか否かを問わないものとします。いかなる場合も、TIリソースまたはその使用に関連して、またはそれらにより発生した、実際の、直接的、特別、付随的、間接的、懲罰的、偶発的、または、結果的な損害について、そのような損害の可能性についてTIが知らされていたかどうかにかかわらず、TIは責任を負わないものとします。

お客様は、この注意事項の条件および条項に従わなかったために発生した、いかなる損害、コスト、損失、責任からも、TIおよびその代表者を完全に免責するものとします。

この注意事項はTIリソースに適用されます。特定の種類の資料、TI製品、およびサービスの使用および購入については、追加条項が適用されます。これには、半導体製品(<http://www.ti.com/sc/docs/stdterms.htm>)、評価モジュール、およびサンプル(<http://www.ti.com/sc/docs/sampterms.htm>)についてのTIの標準条項が含まれますが、これらに限られません。