

TI Designs: TIDA-01539

車載エレクトロクロミック・ミラー用の自動調光ミラーのリファレンス・デザイン



概要

今日の自動車は、自動調光ミラーを使用してグレアを防止し、ドライバの視界が消失することを防いでいます。このリファレンス・デザインは、人間の目に対応する新しい環境光センサと大電流のアンプ段を活用して、容量性のエレクトロクロミック・ミラー負荷を駆動します。

リソース

TIDA-01539	デザイン・フォルダ
OPT3001-Q1	プロダクト・フォルダ
DAC101C081Q	プロダクト・フォルダ
TLV316-Q1	プロダクト・フォルダ
TPS7B69-Q1	プロダクト・フォルダ

特長

- 人間の目に対応する光センサ
- 10ビット出力
- 3.3V、400mAの容量性負荷ドライバ
- エレクトロクロミック負荷の高速な放電
- 広いVBATでの動作(最高40V)
- Liconエレクトロクロミック・ミラーで使用するよう設計

アプリケーション

- 後部ミラー
- サイド・ミラー

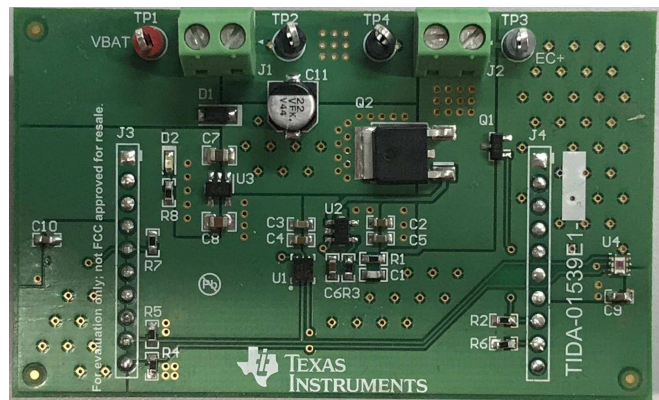
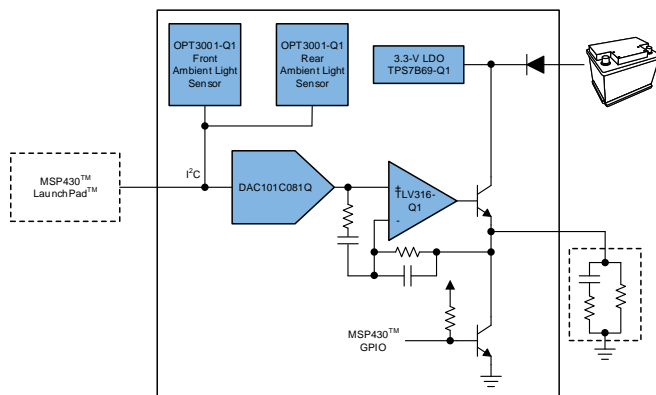
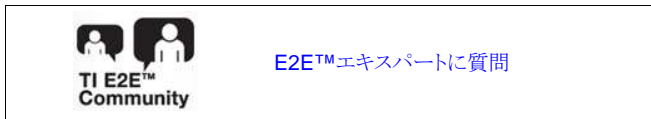

使用許可、知的財産、その他免責事項は、最終ページにあるIMPORTANT NOTICE (重要な注意事項)をご参照くださいますようお願いいたします。

1 System Description

Auto-dimming mirrors allow for active adjustment of rear and side mirrors to reduce glare generated by bright sources of light outside of a vehicle. Electrochromic smart glass uses electrical stimulation to darken and lower reflections of light. The combination of accurate ambient light sensors, a precise digital-to-analog converter (DAC), and an operational amplifier (op amp) driver stage creates a smart auto-dimming mirror solution.

1.1 Key System Specifications

表 1. Key System Specifications

PARAMETER	SPECIFICATIONS	DETAILS
Input voltage range	4 V to 40 V	2.3.4
Output driver range	0 V to 3.3 V	2.3.3
Output current	500 mA	2.3.3
Output resolution	10 bit	2.3.2
Maximum full-scale light capture range	83865.60 lux	2.3.1

2 System Overview

2.1 Block Diagram



図 1. TIDA-01359 Block Diagram

2.2 Highlighted Products

2.2.1 OPT3001-Q1

The OPT3001-Q1 device is an optical sensor that measures the intensity of visible light. The spectral response of the sensor tightly matches the photooptic response of the human eye and includes significant infrared (IR) rejection.

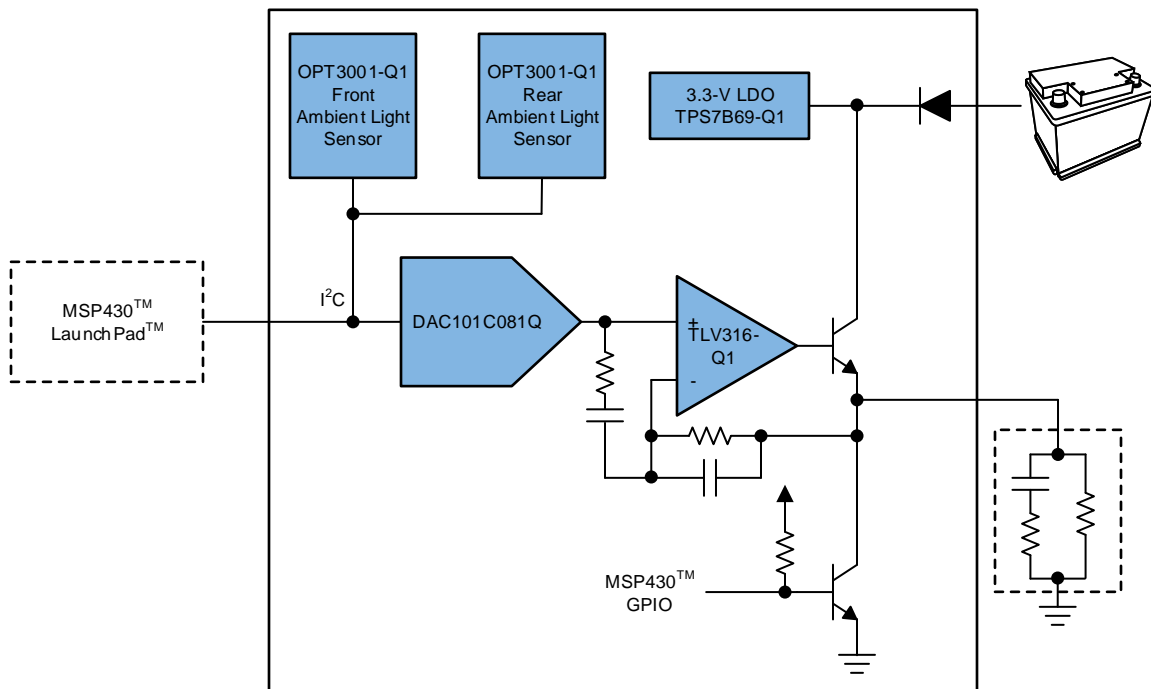
The OPT3001-Q1 device is a single-chip lux meter, measuring the intensity of light as visible by the human eye. The precision spectral response and strong IR rejection of the device enables the OPT3001-Q1 device to accurately meter the intensity of light as seen by the human eye, regardless of light source. The strong IR rejection also helps maintain high accuracy when an industrial design requires mounting the sensor under dark glass for aesthetics. The OPT3001-Q1 device is designed for systems that create light-based experiences for humans, and an ideal preferred replacement for photodiodes, photoresistors, or other ambient light sensors with less human eye matching and IR rejection.

図 2 shows the OPT3001-Q1 block diagram and 図 3 shows the OPT3001-Q1 spectral response.



図 2. OPT3001-Q1 Block Diagram



図 3. OPT3001-Q1 Spectral Response

2.2.2 DAC101C081Q

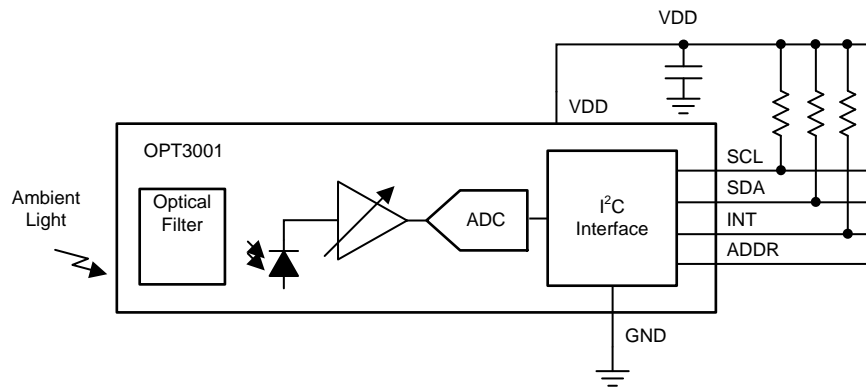
The DAC101C081Q device is a 10-bit, single channel, voltage-output digital-to-analog converter (DAC) that operates from a 2.7-V to 5.5-V supply. The output amplifier allows rail-to-rail output swing and has a 6- μ sec settling time. The DAC101C081 uses the supply voltage as the reference to provide the widest dynamic output range and typically consumes 132 μ A while operating at 5.0 V. The DAC101C081Q is available in 6-lead SOT and WSON packages and provides three address options (pin selectable).

図 4 shows the DAC101C081Q block diagram.

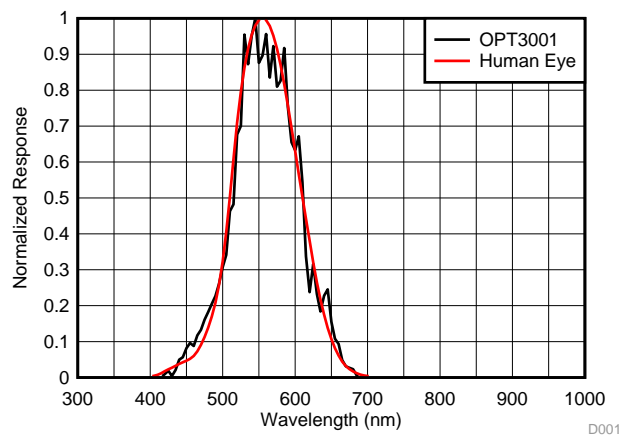

図 4. DAC101C081Q Block Diagram

2.2.3 TLV316-Q1

The TLV316 is a general-purpose, low-power op amp. Features such as rail-to-rail input and output swings, low quiescent current (400 μ A/ch typical) combined with a wide bandwidth of 10 MHz, and very-low noise (12 nV/ $\sqrt{\text{Hz}}$ at 1 kHz) make the device attractive for a variety of applications that require a good balance between cost and performance. The low input bias current supports op amps that are used in applications with M Ω source impedances.

The robust design of the TLV316 provides ease-of-use to the circuit designer through a unity-gain stable, integrated radio frequency interference (RFI) and electromagnetic interference (EMI) rejection filter, no phase reversal in overdrive condition, and high electrostatic discharge (ESD) protection (4-kV human body model (HBM)).

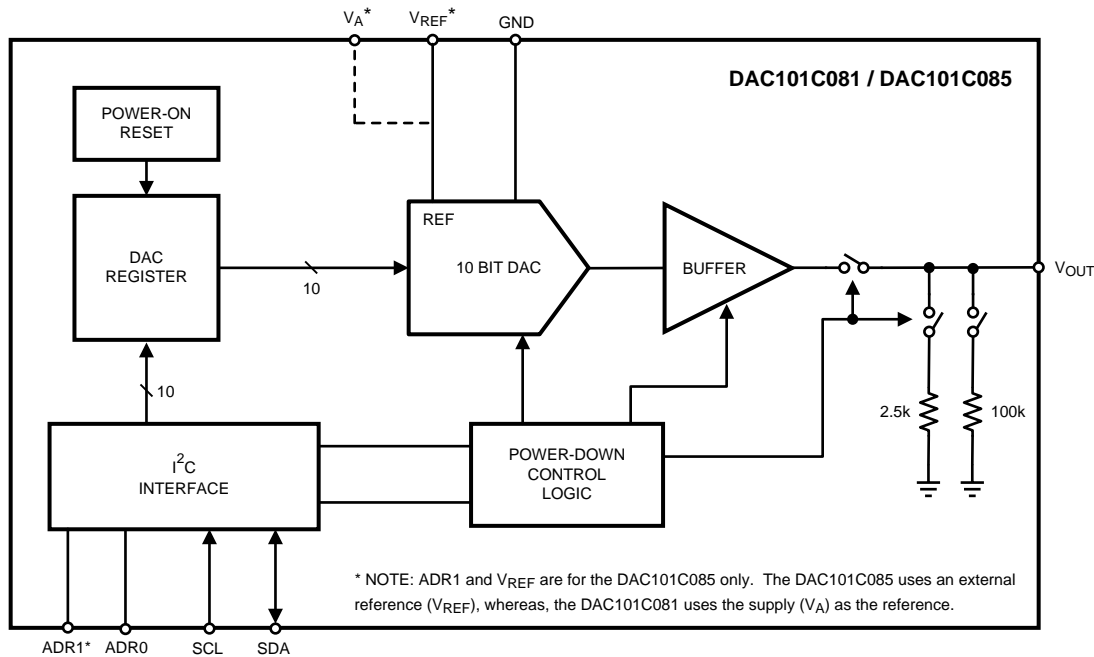
図 5 shows the TLV316-Q1 block diagram.



図 5. TLV316-Q1 Block Diagram

2.2.4 TPS7B69-Q1

The TPS7B69-Q1 device is a low-dropout linear regulator designed for up to 40-V VI operations. With only 15- μ A (typical) quiescent current at light load, the device is suitable for standby microcontrol-unit systems, especially in automotive applications. The device also features integrated short-circuit and overcurrent protection.

The TPS7B69-Q1 device operates over a -40°C to 125°C temperature range. Because of these features, the TPS7B69-Q1 is well suited in power supplies for various automotive applications.

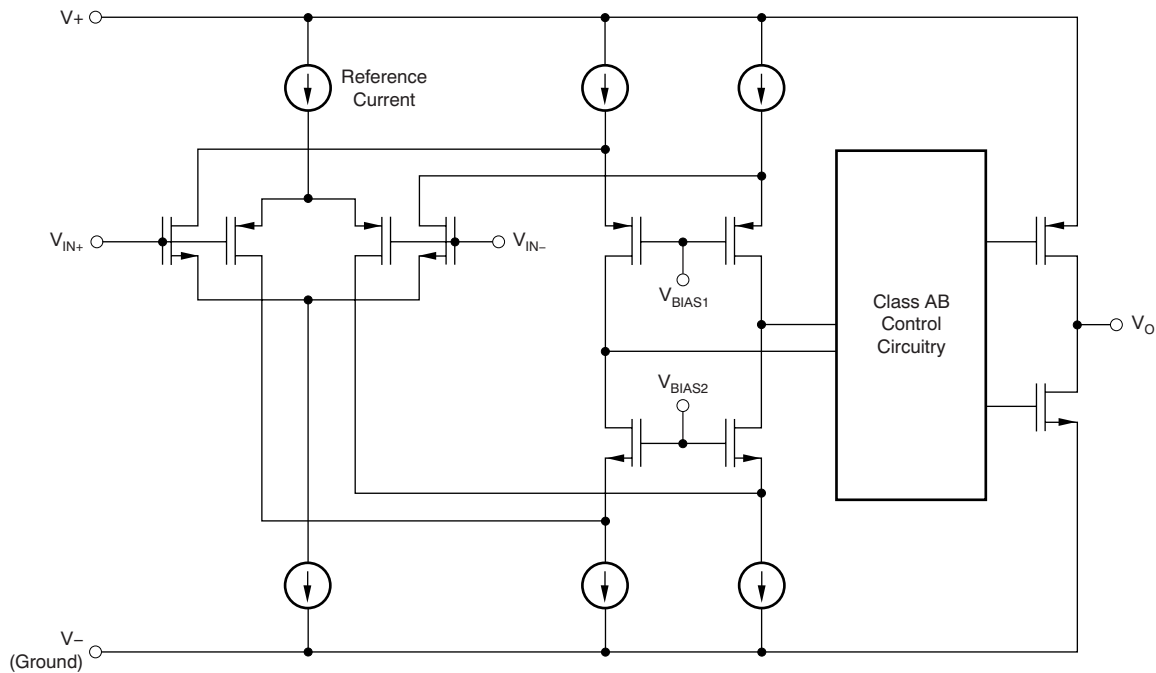
In this design, the TPS7B6933-Q1 was used for its 3.3V output configuration to power an MSP430 microcontroller and the OPT3001-Q1 light sensors.

2.3 System Design Theory

2.3.1 Ambient Light Sensors

This reference design uses two ambient light sensors. One sensor acts as a reference for the amount of general ambient light present outside of the vehicle. This typical location for this sensor is facing out of the back of the mirror module toward the front of the vehicle. The purpose of the other sensor is to capture the light intensity of potential obstructions coming from the rear of the car. This sensor faces toward the back of the vehicle.

The OPT3001 ambient light sensor is very simple to design around by following the standard guidelines provided in the data sheet. A localized 100-nF decoupling capacitor for the 3.3-V supply is the only external component necessary. To set individual addresses for both light sensors, the ADDR pin on one device is tied to VDD and the other is tied to ground. lists the I²C addresses.

表 2. OPT3001 I²C Address Configuration

OPT3001 SCHEMATIC INDICATOR	ADDR NET	I ² C ADDRESS
U4	GND	1000100b, 44h
U5	VDD	1000101b, 45h

The I²C lines, SCL and SDA, are shared between these devices and the DAC101C081. Use an off-board I²C master, such as the MSP430™ MCU LaunchPad™ Development Kit, to control I²C. The INT pins of the device are tied individually to a general-purpose input/output (GPIO) pin. All of these pins are pulled up to 3.3 V with 10-kΩ resistors.

Additional guidance related to optics and proper packaging of the light sensors for ideal light capture depend on the application. Find more details in [OPT3001: Ambient Light Sensor Application Guide](#)

2.3.1.1 Configuration of OPT3001

For this design, the ambient light sensors are configured into different modes over I²C.

2.3.1.1.1 Latched Window-Style Comparison Mode

The device which captures the general ambient light around the car uses a mode called latched window-style comparison. This mode is an interrupt reporting mechanism which allows the device to recognize a fault event whenever a user-configured light intensity is reached. The INT pin of the OPT3001 triggers high or low based on a set hysteresis-style limit window. The toggling of this pin then indicates whether or not the MCU must capture the light intensity of the other OPT3001 sensor and drive the electrochromic (EC) mirror appropriately. Register addresses 0x02 and 0x03 control the low and high limit, respectively, and the designer must configure these appropriately for the application.

2.3.1.2 Lux-Scaled Range Mode

The other OPT3001 sensor is responsible for capturing the light intensity of possible light obstructions reflected by the mirror. The designer can configure this sensor to capture a specific range of light and scale the digital output appropriately. The lux captured by the OPT3001 can be read from the result register (0x01) as a 16 bit value. The 4 most significant bits (MSB), bits 15 through 12, set the scaling of output in lux per least significant bit (LSB), and are known as the “LSB_Size” exponent bits. The other 12 bits (bits 11 to 0) are a linear fractional result from 0 lux to the full scale set by LSB_Size. 表 3 and 表 4 list the full-scale range and LSB_Size values.

表 3. OPT3001 Result Register Field Descriptions

BIT	FIELD	TYPE	RESET	DESCRIPTION
15:12	E[3:0]	R	0h	Exponent. These bits are the exponent bits. 表 4 provides further details.
11:0	R[11:0]	R	000h	Fractional result. These bits are the result in straight binary coding (zero to full-scale).

表 4. OPT3001 Full-Scale Range and LSB Size as Function of Exponent Level

E3	E2	E1	E0	FULL-SCALE RANGE (lux)	LSB SIZE (lux per LSB)
0	0	0	0	40.95	0.01
0	0	0	1	81.90	0.02
0	0	1	0	163.80	0.04
0	0	1	1	327.60	0.08
0	1	0	0	655.20	0.16

表 4. OPT3001 Full-Scale Range and LSB Size as Function of Exponent Level (continued)

E3	E2	E1	E0	FULL-SCALE RANGE (lux)	LSB SIZE (lux per LSB)
0	1	0	1	1310.40	0.32
0	1	1	0	2620.80	0.64
0	1	1	1	5241.60	1.28
1	0	0	0	10483.20	2.56
1	0	0	1	20966.40	5.12
1	0	1	0	41932.80	10.24
1	0	1	1	83865.60	20.48

Use to translate the binary value to the appropriate lux value:

$$\text{lux} = \text{LSB_Size} \times R[11:0] \tag{1}$$

where,

- $\text{LSB_Size} = 0.01 \times 2^{E[3:0]}$.

The configuration register 0x01 allows the designer to specify the LSB_Size to set the maximum lux value for capture by the OPT3001 sensor. Make this setting based on the application-specific requirements of the design. The MCU can then perform any translation of the 16-bit OPT3001 data and then generate a 10-bit value to send to the DAC101C081 device.

Figure 6 shows the schematic for the ambient light sensors.

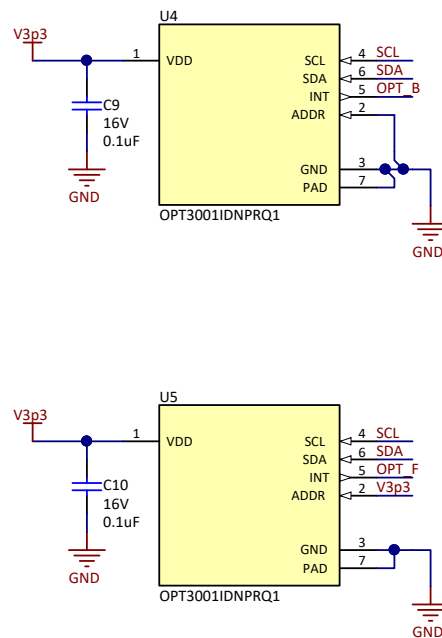

Figure 6. Ambient Light Sensors Schematic

2.3.2 DAC

The DAC101C081 is an I²C-controlled DAC that requires minimal external components for normal functionality. This device uses the VA pin as both the device supply voltage as well as the reference voltage for the DAC. The user must implement two local decoupling capacitors (4.7 μ F and 100 nF) to ensure typical operation.

To configure the DAC101C081 address, the ADR0 pin is tied to the supply voltage, which represents a device address of 0x0E.

A 10-bit value can be written to the DAC, generating a 0-V to 3.3-V output to drive the output buffer amplifier stage. While dependent on the EC mirror, the typical maximum output required to drive the mirror is approximately 2 V, or a DAC code of 0x26C.

Figure 7 shows the DAC schematic.

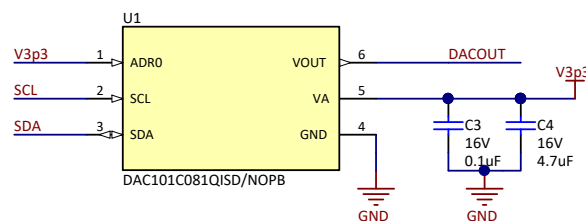

Figure 7. DAC Schematic

2.3.3 Electrochromic Mirror Driver

The electrochromic (EC) mirror utilizes a proprietary electrochromic chemical placed between two conductive layers and glass panels. When a voltage is applied to these conductive elements, the current flow through the chemical causes it to change in color and darken. Electrically, the electrochromic mirror behaves like a very large capacitor, typically greater than 1 F, as well as a small shunt resistance. The total capacitance measured largely depends on the total area of the mirror.

2.3.3.1 High-Current Buffer Amplifier

To drive this mirror, the voltage output necessary is less than 2 V for the maximum amount of dimming. Due to the size of this capacitive load, the current necessary to charge it can reach as much as 400 mA. A steady state of approximately 150 mA is also required to maintain proper dimming. To meet these specifications, use an op amp and Darlington bipolar junction transistor BJT to buffer from the output of the DAC101C081 and drive the electrochromic load. The BJT sources the current for the load and the use of an op amp feedback provides stability and linearity regardless of the temperature or process variation of the BJT.

The MJD122 Darlington-pair BJT is chosen for its large 100-V collector-emitter voltage to allow use across both the typical and non-typical automotive battery operating voltage range, as well as the very-large, 8-A continuous current operation. The DPAK package is great for dissipating heat generated by the typical 2 W of power flowing through the device.

2.3.3.2 Buffer Amplifier Stability for Very-Large Capacitive Loads

Due to the size of the capacitive load, stability of the buffer amplifier is a concern. Designers can improve capacitive load stability through the use of both noise gain and capacitive feedback compensation.

Using rate of closure analysis provides a guideline on the expected phase margin on an amplifier based on the angle of the slopes between the modified open loop gain and $1/\beta$ bode plots. A key rule is to ensure the rate of closure is not greater than 20 dB/decade, which ensures the phase margin of the design is greater than 45°. For more information on op amps and stability, see the training resource [TI Precision Labs - Ops Amps: Stability 2](#).

The noise gain compensation consists of implementing high-frequency gain to allow the $1/\beta$ of the amplifier to be larger than the modified open-loop gain at the pole introduced by the capacitive load, which allows the rate of the closure to be 20 dB/decade rather than 40 dB/decade. This method retains the desired 0-dB gain at DC that allows the amplifier to continue to operate as a buffer. The noise gain provides the necessary bump in the phase margin to maintain stability across the entire bandwidth of the amplifier and prevent ringing.

This high-frequency gain is implemented with R1, R3, and C6, which creates a zero and provides a 20-dB/decade slope on the $1/\beta$ plot above approximately 1 kHz. The rate of closure at the intersection is then $|-40 \text{ dB/decade} + 20 \text{ dB/decade}| = 20 \text{ dB/decade}$.

To add to the stability improvements found with noise gain, an additional capacitor C1 is used to implement a capacitive feedback, or C_f , compensation. This additional high-frequency pole boosts the phase even more in the area of concern.

Figure 8 shows a TINA simulation of the bode plot without the noise gain implemented and Figure 9 shows the result of the noise gain.

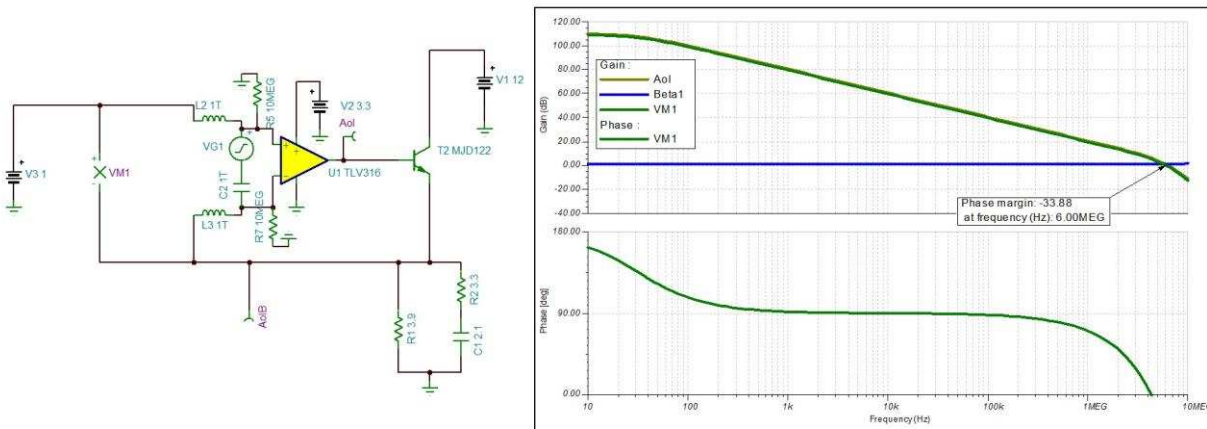

Figure 8. TINA-TI™ Stability Analysis of EC Mirror Driver Without Compensation



図 9. TINA-TI™ Stability Analysis of EC Mirror Driver With Compensation

2.3.3.3 Fast Discharge of Large Capacitive Load

If the voltage applied to the mirror is set to 0 V, the capacitance on the mirror slowly discharges and the electrochromic element returns to a transparent, non-colored state. To accelerate the discharge of the capacitive load and reduce the amount of time to reach the transparent state, use a low-side transistor.

This simple open-drain transistor can be turned on by pulling the base high, which provides a direct path to ground for the capacitance on the mirror. Take care to ensure this transistor is only enabled when the output of the DAC has already been set to 0 V to prevent unnecessary current flow through the voltage buffer output and this transistor.

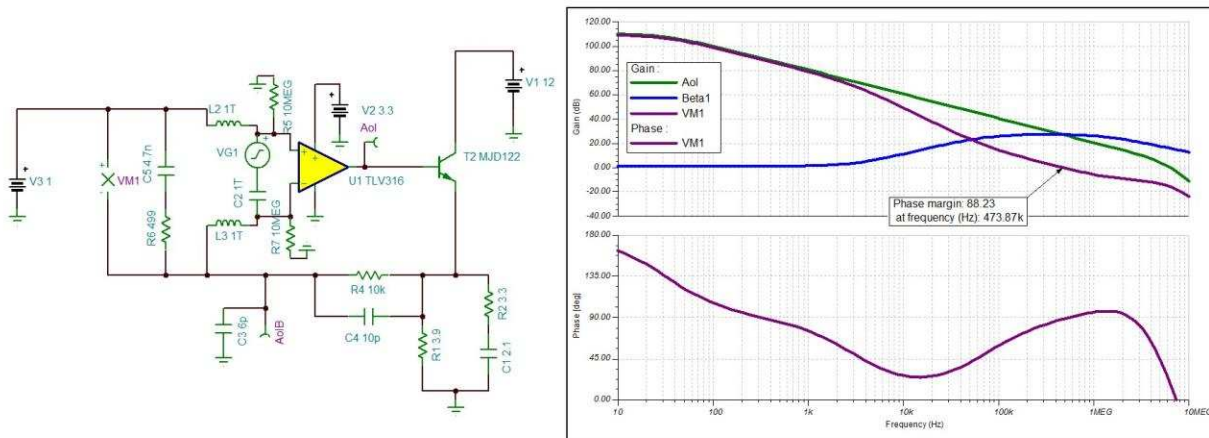
The base of this transistor is tied to a GPIO on the MCU which controls this design. Use a local pullup resistor of 4.7 kΩ with the open-drain output of the MCU GPIO.

図 10 shows the EC mirror driver schematic.



図 10. EC Mirror Driver Schematic

2.3.4 Linear Regulator

This design uses a single 3.3-V output TPS7B6933-Q1 linear dropout regulator (LDO) to power all components on the design. This device has a wide input voltage range for operation and protection for the entire possible battery operating voltage range.

The TPS7B6933-Q1 requires both input and output voltage decoupling. The device data sheet recommends that the input capacitor be larger than 0.1 μF and the output capacitor be between 2.2 μF and 100 μF . A 4.7- μF value is chosen for the input capacitor and 2.2 μF is used as an output capacitor.

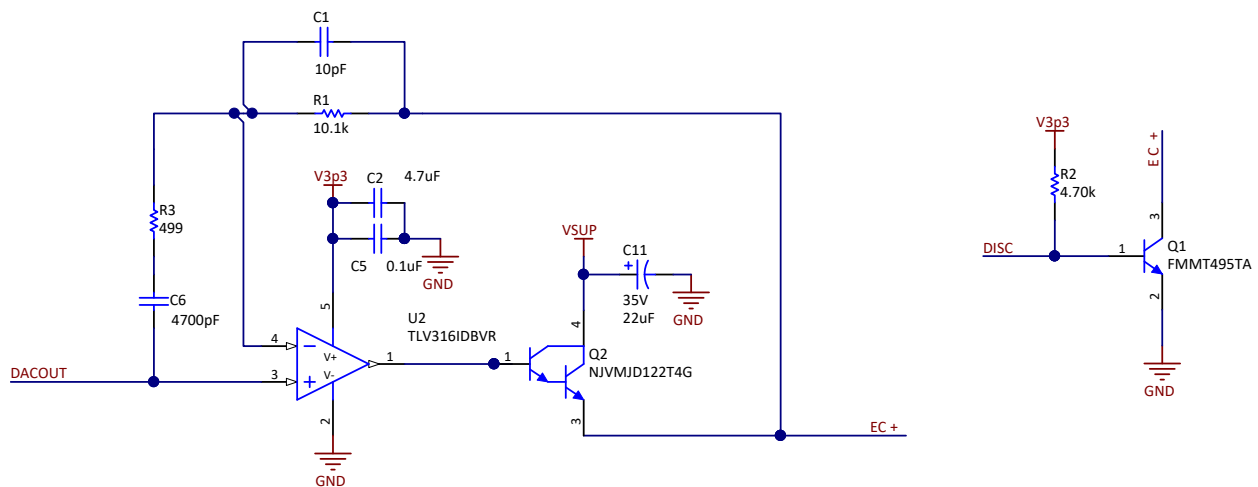
☒ 11 shows the LDO configuration schematic.

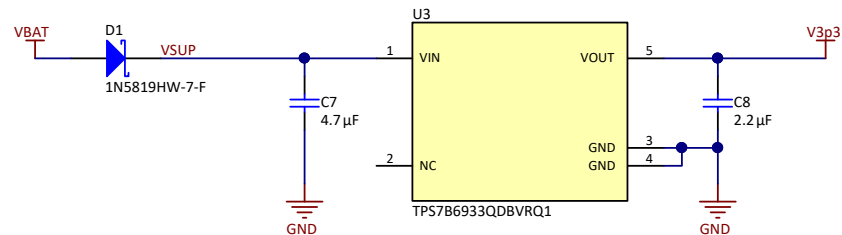

☒ 11. LDO Configuration Schematic

3 Hardware, Software, Testing Requirements, and Test Results

3.1 Required Hardware and Software

3.1.1 Hardware

The TIDA-01539 reference design requires the use of an MCU for full functionality. The design has been outfitted with 10x1 connectors to connect to a MSP-EXP430G2552 LaunchPad.

The reference design board provides jumper J1 for tying a typical automotive battery voltage of 12 V to the design. The 3.3-V output of the LDO has been tied to the appropriate pin to also power the MSP430 LaunchPad from this power supply.

The designer can connect an electrochromic mirror to the design using jumper J2.

A simple firmware was developed for the MSP430 MCU to test the board to capture the OPT3001 value, write an appropriate value to the DAC, and monitor and control the GPIOs.

Figure 12 shows the schematic of the jumper connections and Figure 13 shows an image of reference design connected to the MSP-EXP430G2552 LaunchPad.

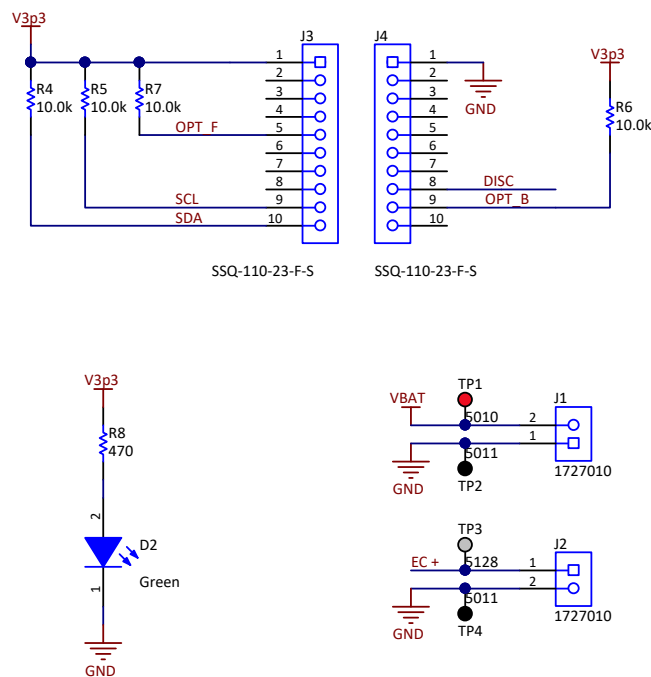

Figure 12. Schematic of Jumper Connections



図 13. Image of TIDA-01539 Connected to MSP-EXP430G2552 LaunchPad™

3.2 Testing and Results

3.2.1 Test Setup

The testing was performed with the TIDA-01539 PCB and the MSP-EXP430G2552 Launchpad. A 12-V power supply was connected to J1 and a standard Licon electrochromic mirror was connected to J2. Multiple firmware algorithms were utilized for different testing modes. [Figure 14](#) shows an image of the test setup and provides the electrical specifications for the Licon mirror.

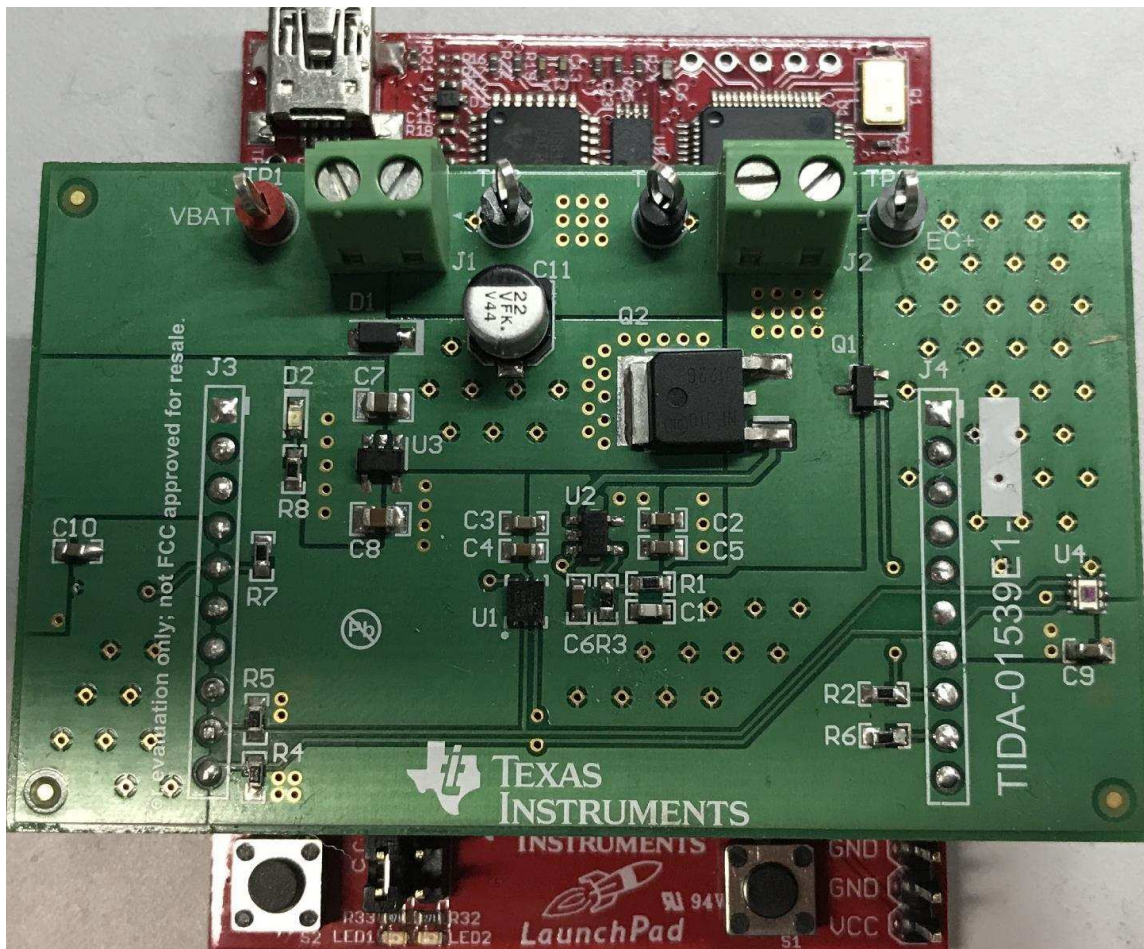

図 14. TIDA-01539 Test Setup

表 5. Licon 4th Layer Reflectance Electrochromic Mirror Specifications

Item	Specification
Operating Voltage	0 - 1.45 VDC
Peak Current	≤350 mA @ 1.2V
Average Current	≤180 mA @ 1.2 V
Operating Temperature	-40 °C to 85 °C
Time to Change (65% to 15% opacity, 25°C)	≤8 Sec (1.4V applied to mirror)
Time to Change (15% to 65% opacity, 25°C, no additional fast discharge)	≤10 Sec (0V applied to mirror)

3.2.2 Test Results

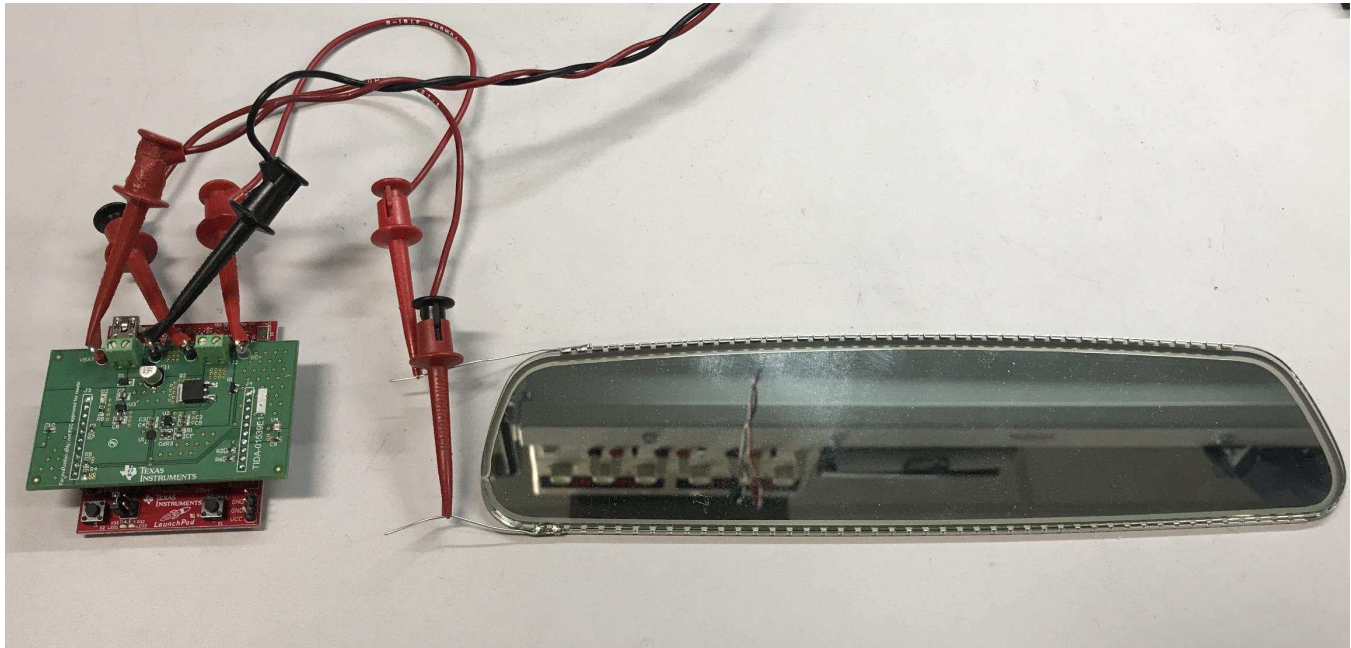
3.2.2.1 EC Mirror Driver Stability

A simple program was created to maintain the DAC drive from 0 V to 1.5 V and monitor the impulse response of the EC mirror driver for stability with a large capacitive load. Aside from a slight overshoot, the design shows no stability issues (see [Figure 15](#)).



図 15. Impulse Response of EC Mirror Driver Stage With Typical Electrochromic Load

3.2.3 Fast Discharge of Mirror

The design was tested with and without the fast discharge transistor, which was used to show its affect on the amount of time required for the mirror to return to its completely transparent state.

This test drives the mirror from 1.5 V to 0 V and then measures the voltage monitored across the mirror as it discharges.

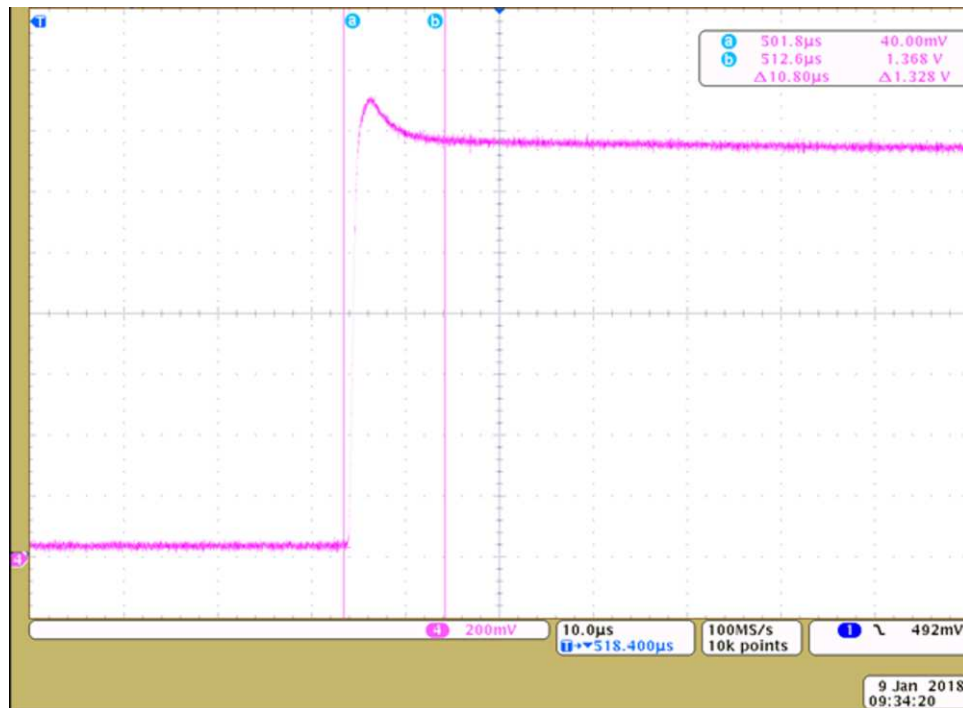
Without the circuit, discharge of the mirror takes more than 20 seconds to reach 0 V and a completely clear state (see 図 16).

To implement the fast discharge, set the DAC to drive to 0 V, after which the MCU waits about 200 ms and then pulls the transistor base high. The mirror then discharges completely to 0 V within an instant and returns to a completely clear state within a few seconds (see 図 17).



図 16. Discharge of Capacitive Load Without Fast Discharge Circuit



図 17. Discharge of Capacitive Load With Fast Discharge Enabled

4 Design Files

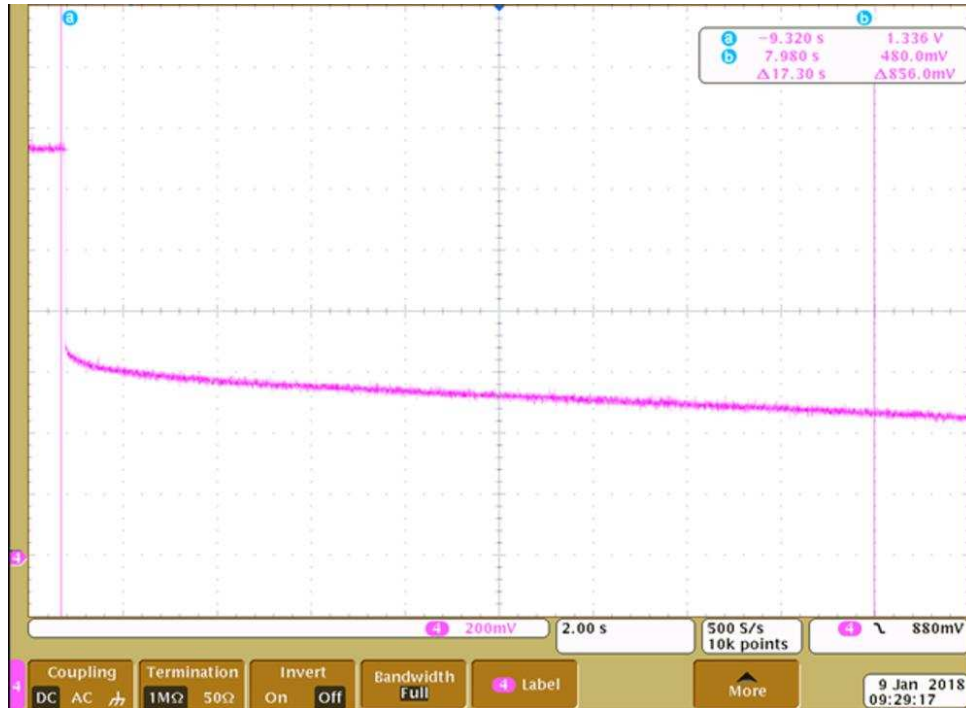
4.1 Schematics

To download the schematics, see the design files at [TIDA-01539](#).

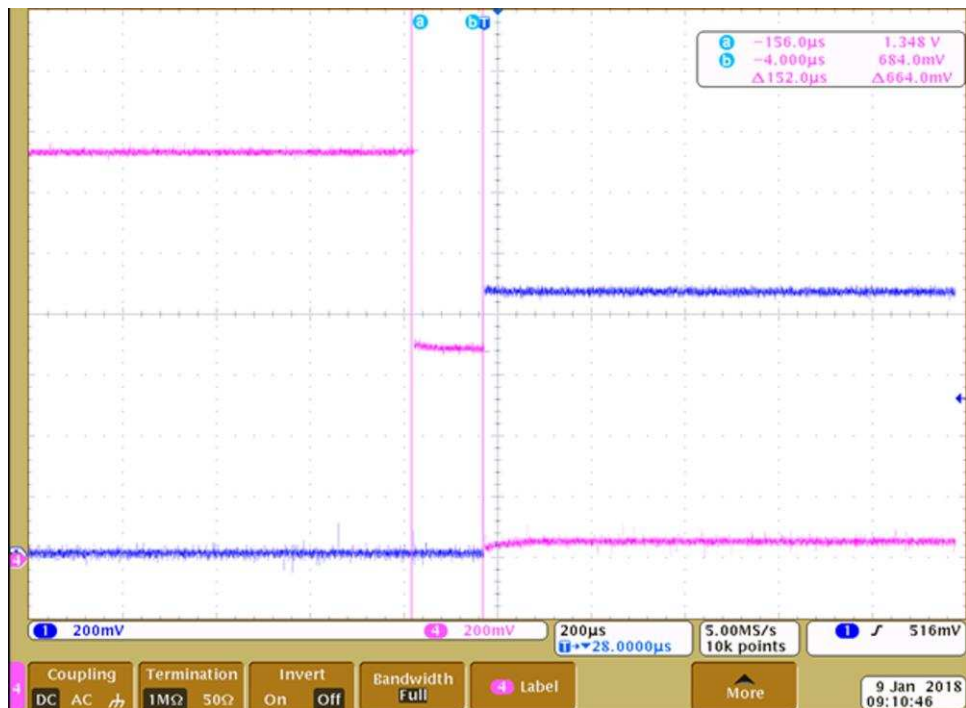
4.2 Bill of Materials

To download the bill of materials (BOM), see the design files at [TIDA-01539](#).

4.3 PCB Layout Recommendations

4.3.1 Layout Prints

To download the layer plots, see the design files at [TIDA-01539](#).

4.4 Altium Project

To download the Altium project files, see the design files at [TIDA-01539](#).

4.5 Gerber Files

To download the Gerber files, see the design files at [TIDA-01539](#).

4.6 Assembly Drawings

To download the assembly drawings, see the design files at [TIDA-01539](#).

5 Software Files

To download the software files, see the design files at [TIDA-01539](#).

6 Related Documentation

1. Texas Instruments, [OPT3001: Ambient Light Sensor Application Guide](#)

6.1 商標

E2E, MSP430, LaunchPad, TINA-TI are trademarks of Texas Instruments.
すべての商標および登録商標はそれぞれの所有者に帰属します。

7 Terminology

BJT— Bipolar junction transistor

DAC— Digital-to-analog converter

EC— Electrochromic mirror

EMI— Electromagnetic interference

ESD— Electrostatic discharge

GPIO— General-purpose input/output (pins)

HBM— Human body model

IR— Infrared

LDO— Low-dropout linear regulator

LSB— Least significant bit

MCU— Microcontroller

MSB— Most significant bit

PCB— Printed-circuit board

RFI— Radio frequency interference

8 About the Author

MATTHEW SULLIVAN is a systems engineer at Texas Instruments. As a member of the Automotive Systems Engineering team, Matt focuses on body electronics and lighting, creating block diagrams and reference designs for automotive customers. Matt acquired his B.S.E.E. in 2012 from the University of Southern California in Los Angeles, CA.

TIの設計情報およびリソースに関する重要な注意事項

Texas Instruments Incorporated ("TI")の技術、アプリケーションその他設計に関する助言、サービスまたは情報は、TI製品を組み込んだアプリケーションを開発する設計者に役立つことを目的として提供するものです。これにはリファレンス設計や、評価モジュールに関係する資料が含まれますが、これらに限られません。以下、これらを総称して「TIリソース」と呼びます。いかなる方法であっても、TIリソースのいずれかをダウンロード、アクセス、または使用した場合、お客様(個人、または会社を代表している場合にはお客様の会社)は、これらのリソースをここに記載された目的にのみ使用し、この注意事項の条項に従うことに合意したものとします。

TIによるTIリソースの提供は、TI製品に対する該当の発行済み保証事項または免責事項を拡張またはいかなる形でも変更するものではなく、これらのTIリソースを提供することによって、TIにはいかなる追加義務も責任も発生しないものとします。TIは、自社のTIリソースに訂正、拡張、改良、およびその他の変更を加える権利を留保します。

お客様は、自らのアプリケーションの設計において、ご自身が独自に分析、評価、判断を行う責任がお客様にあり、お客様のアプリケーション(および、お客様のアプリケーションに使用されるすべてのTI製品)の安全性、および該当するすべての規制、法、その他適用される要件への遵守を保証するすべての責任をお客様のみが負うことを理解し、合意するものとします。お客様は、自身のアプリケーションに関して、(1) 故障による危険な結果を予測し、(2) 障害とその結果を監視し、および、(3) 損害を引き起こす障害の可能性を減らし、適切な対策を行う目的での、安全策を開発し実装するために必要な、すべての技術を保持していることを表明するものとします。お客様は、TI製品を含むアプリケーションを使用または配布する前に、それらのアプリケーション、およびアプリケーションに使用されているTI製品の機能性を完全にテストすることに合意するものとします。TIは、特定のTIリソース用に発行されたドキュメントで明示的に記載されているもの以外のテストを実行していません。

お客様は、個別のTIリソースにつき、当該TIリソースに記載されているTI製品を含むアプリケーションの開発に関連する目的でのみ、使用、コピー、変更することが許可されています。明示的または黙示的を問わず、禁反言の法理その他どのような理由でも、他のTIの知的所有権に対するその他のライセンスは付与されません。また、TIまたは他のいかなる第三者のテクノロジーまたは知的所有権についても、いかなるライセンスも付与されるものではありません。付与されないものには、TI製品またはサービスが使用される組み合わせ、機械、プロセスに関連する特許権、著作権、回路配置利用権、その他の知的所有権が含まれますが、これらに限られません。第三者の製品やサービスに関する、またはそれらを参照する情報は、そのような製品またはサービスを利用するライセンスを構成するものではなく、それらに対する保証または推奨を意味するものでもありません。TIリソースを使用するため、第三者の特許または他の知的所有権に基づく第三者からのライセンス、もしくは、TIの特許または他の知的所有権に基づくTIからのライセンスが必要な場合があります。

TIのリソースは、それに含まれるあらゆる欠陥も含めて、「現状のまま」提供されます。TIは、TIリソースまたはその仕様に関して、明示的か暗黙的にかかわらず、他のいかなる保証または表明も行いません。これには、正確性または完全性、権原、続発性の障害に関する保証、および商品性、特定目的への適合性、第三者の知的所有権の非侵害に対する黙示的保証が含まれますが、これらに限られません。

TIは、いかなる苦情に対しても、お客様への弁済または補償を行う義務はなく、行わないものとします。これには、任意の製品の組み合わせに関連する、またはそれらに基づく侵害の請求も含まれますが、これらに限られず、またその事実についてTIリソースまたは他の場所に記載されているか否かを問わないものとします。いかなる場合も、TIリソースまたはその使用に関連して、またはそれらにより発生した、実際の、直接的、特別、付随的、間接的、懲罰的、偶発的、または、結果的な損害について、そのような損害の可能性についてTIが知らされていたかどうかにかかわらず、TIは責任を負わないものとします。

お客様は、この注意事項の条件および条項に従わなかったために発生した、いかなる損害、コスト、損失、責任からも、TIおよびその代表者を完全に免責するものとします。

この注意事項はTIリソースに適用されます。特定の種類の資料、TI製品、およびサービスの使用および購入については、追加条項が適用されます。これには、半導体製品(<http://www.ti.com/sc/docs/stdterms.htm>)、評価モジュール、およびサンプル(<http://www.ti.com/sc/docs/sampterms.htm>)についてのTIの標準条項が含まれますが、これらに限られません。