

# Design Guide: TIDA-010059

## ホール効果電流センサを使用した 230V<sub>AC</sub> モータ・ドライブ用インフェーズ電流検出のリファレンス・デザイン



### 概要

このリファレンス・デザインでは、1% 未満の絶対誤差 (-40~125°C) で電流を測定でき最高 600V の動作絶縁電圧を実現できるホール効果電流センサ TMCS1100 を紹介します。パッケージに内蔵した電流検出素子の抵抗が小さいこと、ハイサイド電源が不要なことから、モータのトルク、速度、位置を精密に制御するための小型で高効率の電流センシング・ソリューションを実現できます。インバータの電力段は 600V の LMG3411 GaN (窒化ガリウム) パワー・モジュールで構成されているため、次世代のモータ・ドライブ向けにさらなる小型化と効率向上が可能です。

### リソース

- TIDA-010059 デザイン・フォルダ
- TMCS1100 プロダクト・フォルダ
- LMG3411R050 プロダクト・フォルダ
- ISO7721 プロダクト・フォルダ
- REF2030 プロダクト・フォルダ
- TLV9001 プロダクト・フォルダ
- TL431 プロダクト・フォルダ
- TLV1117 プロダクト・フォルダ
- TMDSCNCD280049C ツール・フォルダ

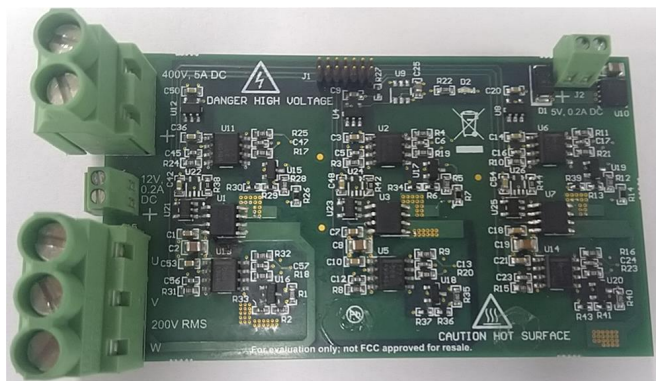

### 特長

- 高精度の電流検出 (絶対誤差 1% 未満) により、精密なモータ制御が可能
- 広い温度範囲にわたって精度が安定しているため、オフセットまたはドリフトの外部補償が不要
- 検出素子をパッケージに内蔵していること、ハイサイド電源が不要なことから、フットプリントの小さい低コストの電流検出システムを実現可能
- ゲート低電圧、デバイス過電流、過熱に対する保護機能を備えた 600V の LMG3411 GaN パワー・モジュールを使用した、高効率で小型のインバータ電力段

### アプリケーション

- AC インバータと VF ドライブ
- UPS システム、ソーラー・インバータ
- EV 充電

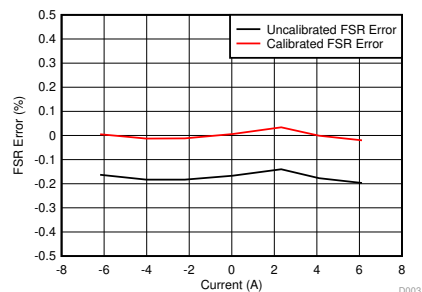
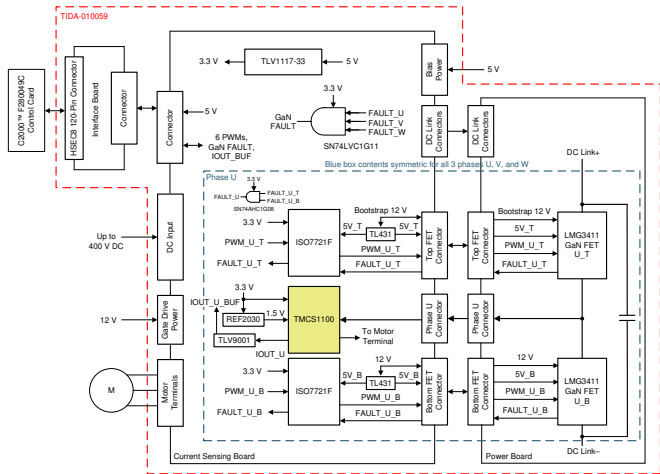



使用許可、知的財産、その他免責事項は、最終ページにあるIMPORTANT NOTICE (重要な注意事項)をご参照くださいますようお願いいたします。

## 1 System Description

Current measurement is at the heart of motor control and protection - precise control of motor torque, speed or position, as well as motor protection from overcurrent or short-circuit faults singularly depend on the quality of the motor current measurement. An accurate, low-latency, high-resolution current measurement system is a prerequisite for a motor-drive system. Additionally, current measurement systems may need features, including isolation, to be implemented at low-cost and minimal part count. For example, at higher operating voltages motor drives need isolated current measurement for safe operation.

Current measurement systems employ either Hall sensors or shunt resistors as the current sense element. Hall sensors have inherent galvanic isolation while shunt resistors need isolation in the subsequent signal-processing chain. Therefore, Hall-effect current sensors are usually a lower part count, lower-cost solution compared to shunt resistors in implementing isolated current measurement. However, shunt resistor based current sensing generally provides higher linearity and bandwidth along with lower temperature drift when compared against Hall-effect current sensing. Thus, typically, the choice available to the designer is between the low-cost, compact, lower measurement performance of Hall-effect current sensing versus the complex, higher-cost, better measurement performance of shunt resistor based current sensing.

The TMCS1100 is a Hall-effect current sensor with a low temperature drift and offset, high linearity, and low sensitivity error. The absolute error in measurement over a wide temperature range (–40 to 125°C) is < 1% without any external drift or offset compensation. These features combine the advantages of both Hall sensor and shunt resistor based systems and enable an accurate, internally temperature stable, simple, low-cost Hall-effect current sensing system. In-package sensing simplifies the PCB layout while the narrow 8-pin SOIC package enables an isolated yet compact current measurement system. Elimination of the shunt resistor also reduces losses and improves efficiency.

This reference design uses a 600-V LMG3411 GaN power module based inverter power stage. The design, construction, and test results of the GaN power module based inverter power stage are explained in the TIDA-00915 [Three-phase, 1.25-kW, 200-VAC small form factor GaN inverter reference design for integrated drives](#) design guide. This reference design focuses on the current sensing for a fast-switching transient inverter like GaN inverter in a motor drive application and demonstrates the following:

- Current measurement accuracy in the presence of fast-switching transients
- Latency in motor current measurement during motor operation

## 1.1 Key System Specifications

表 1. Key System Specifications

SUBSECTION	PARAMETER	SPECIFICATIONS
Current sensing	Type	Hall-effect, in-phase current sensing
	Power-supply ( $V_{CC}$ )	3.3 V to 5 V (low-side)
	Reference ( $V_{REF}$ )	1.5 V, external
	Output	0 to $V_{CC}$ (0 A produces $V_{REF}$ )
Inverter power stage	DC voltage	300 V nominal (400 V maximum)
	Output voltage	Three-phase 230 VAC <sub>RMS</sub>
	Output current <sup>(1)</sup>	3.5 A <sub>RMS</sub> continuous at 50°C, 1.5 A <sub>RMS</sub> continuous at 85°C
	Heatsink	LPD6080-10B
	Efficiency	> 99.3% peak efficiency at 16 kHz
	Cooling	Natural convection cooled
Protection	GaN gate drive power supply UVLO	9.3 V
	GaN overcurrent	40.4 A (minimum)
	GaN overtemperature	165°C
Controller interface	MCU	TMS320F280049C
	Control card	TMDSCNCD280049C
	Signals	3.3 V I/Os: <ul style="list-style-type: none"> <li>• 6 PWM (O)</li> <li>• 3 phase current (I)</li> <li>• 1 combined GaN fault (I)</li> </ul>
PCB information	Power	2 layer, IMS, 80 mm x 46 mm x 1.95 mm
	Current sensing	4 layer, FR-4, 80 mm x 46 mm x 0.8 mm
	Interface	4-layer, FR-4

<sup>(1)</sup> Maximum values depend on thermal system design; the GaN power module is capable of delivering continuous current of 12-A<sub>RMS</sub>

## 2 System Overview

### 2.1 Block Diagram

Figure 1 shows the system block diagram of the TIDA-010059 reference design. The reference design consists of 3 separate PCBs: power board, current sensing board, and interface board.

Figure 1. TIDA-010059 Block Diagram

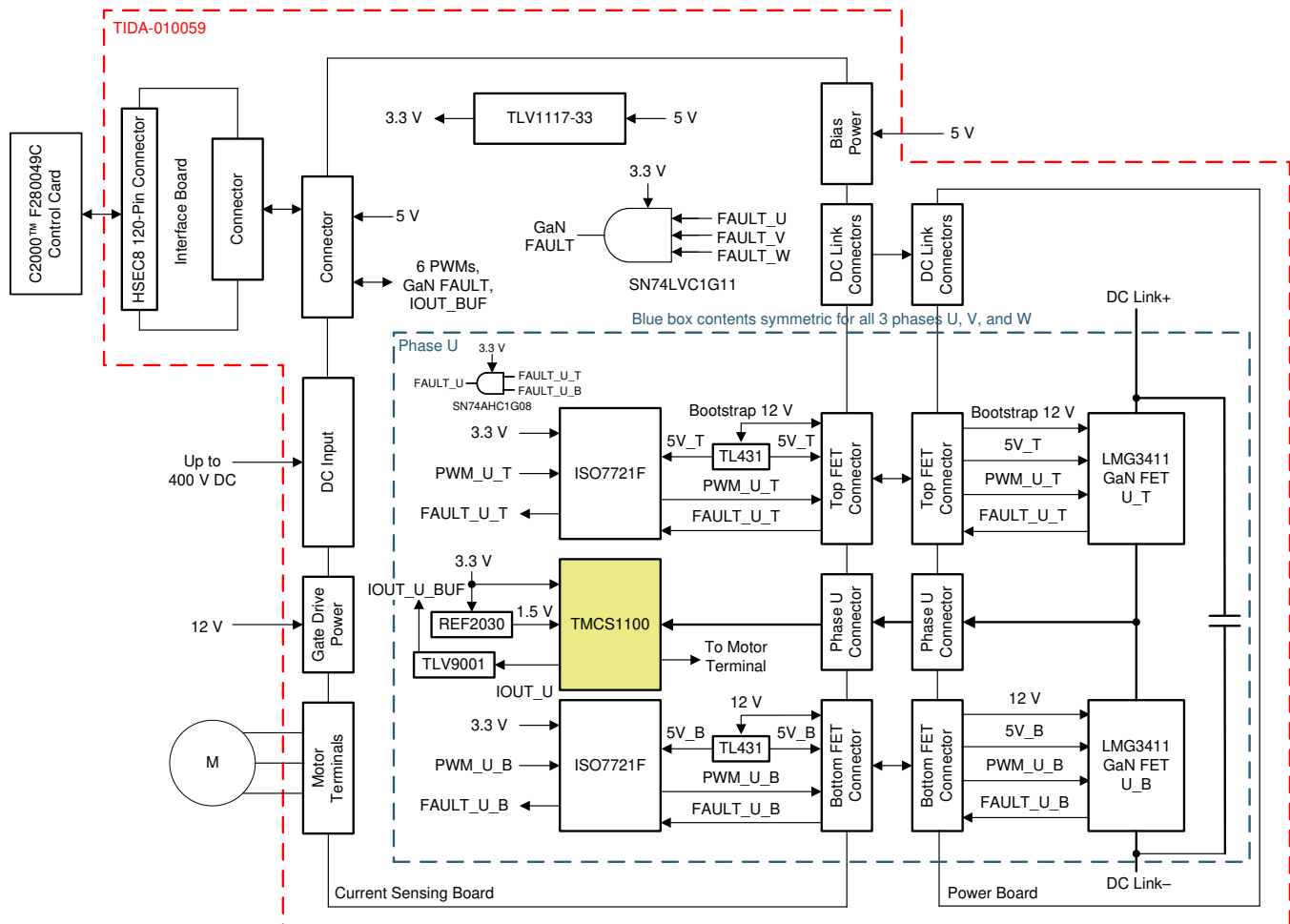

The power board is a 2-layer, 1.95-mm insulated metal substrate (IMS) PCB that employs six 600-V LMG3411R050 GaN power modules. The power board receives the DC link power via low-height 6-pin connectors from the current sensing board. Each GaN power module has a dedicated 6-pin connector to transmit gate drive power, PWM signals, and the fault signal to and from the current sensing board. The power board transmits phase current back to the current board through a similar 6-pin connector for each phase.

The current sensing board is a 4-layer FR-4 PCB that consists of three TMCS1100 Hall-effect current sensors for in-phase current measurement. The current measurement signal processing also includes a REF2030 voltage reference for providing precise external reference to the TMCS1100 device and an optional TLV9001 op-amp buffer in a voltage follower configuration that can be bypassed, if not needed. This board also has six ISO7721F digital isolators that provide isolation between the microcontroller and power stage for transferring PWM and fault signals; in addition it also contains the logic circuits

(SN74AHC1G08, SN74LVC1G11) for combining the active-low fault signals from each of the six GaN power modules into one active low GaN fault signal. The current sensing board holds all the input and output terminals - DC link input, 12-V input for gate drive power supply, 5-V input for control and logic circuitry, and 3-terminal output for motor connection. The 12-V and 5-V inputs are isolated from each other.

The 12-V gate drive power supply biases the three bottom side GaN power modules. The top-side GaN power modules are biased using three separate bootstrap rails derived from the 12-V input. The 5 V for isolator high-side  $V_{DD}$  and GaN low-power mode pullup is derived from the 12-V biasing each GaN module (either the 12-V input or bootstrap rail) using the TL431 device in voltage-regulator mode. The 5-V input is converted to 3.3 V for isolator low side  $V_{DD}$  and logic circuits using an LDO TLV1117 device. The current sensing board connects to the interface board through a 14-pin connector - six PWM signals, three phase current signals, one combined GaN fault signal and 5-V power are transmitted via this connector to the interface board.

The interface board is a 4-layer, 0.8-mm FR-4 PCB that connects to the C2000™ TMDSCNCD280049C control card via a 120-pin HSEC8 connector. The interface board has a low-pass R-C filter on each phase current signal for removing noise. The C2000 control card implements a simple space vector modulated PWM to generate a rotating voltage vector where the frequency of the voltage vector and magnitude can be controlled and also monitors the GaN fault signal. The three phase current signals are tied to the input channels of internal ADC for control and monitoring.

The TMCS1100 device provides a high-precision, isolated measurement of phase currents and this design guide details the performance of the TMCS1100 sensor in a real-time fast-switching transient environment.

## 2.2 Design Considerations

The design uses a 600-V GaN based small form factor inverter power stage and therefore a compact, isolated, highly-noise-immune current-sensing solution is necessary for precise motor control. The TMCS1100, a Hall effect current sensor in a narrow 8-pin SOIC package provides an isolated equivalent current signal immune from fast switching transients up to 25 kV/ $\mu$ s. An accurate, temperature stable external reference voltage is provided to the TMCS1100 current sensor to ensure high accuracy over a wide operating temperature range. An op amp based voltage follower option is available for driving higher capacitance loads - this voltage follower can be bypassed, if not needed. A low-pass R-C filter is available (in the interface board) to remove the high-frequency noise in the equivalent current signal before sampling by internal ADC of the C2000 MCU.

## 2.3 Highlighted Products

### 2.3.1 TMCS1100

The TMCS1100 is a galvanically isolated Hall-effect current sensor capable of DC or AC current measurement with high accuracy, excellent linearity, and temperature stability. A low-drift, temperature-compensated signal chain provides < 1% full-scale error across the entire device temperature range.

The input current flows through an internal 1.8-mΩ conductor that generates a magnetic field measured by an integrated Hall-effect sensor. This structure eliminates external concentrators and simplifies PCB design. Low conductor resistance minimizes power loss and thermal dissipation. Inherent galvanic insulation provides a 600-V basic working isolation and 3-kV dielectric withstand isolation between the current path and circuitry. Integrated electrical shielding enables excellent common-mode rejection and transient immunity protection.

The output voltage is proportional to the input current with four sensitivity options. Fixed sensitivity allows the TMCS1100 device to operate from a single 3-V to 5.5-V power supply, eliminates ratiometry errors, and improves supply noise rejection. The current polarity is considered positive when flowing into the positive input pin. The VREF input pin provides a variable zero-current output voltage, enabling bidirectional or unidirectional current sensing. The TMCS1100 sensor draws a maximum supply current of 5 mA, and all sensitivity options are specified over the operating temperature range of -40°C to 125°C.

図 2. TMCS1100 Functional Block Diagram

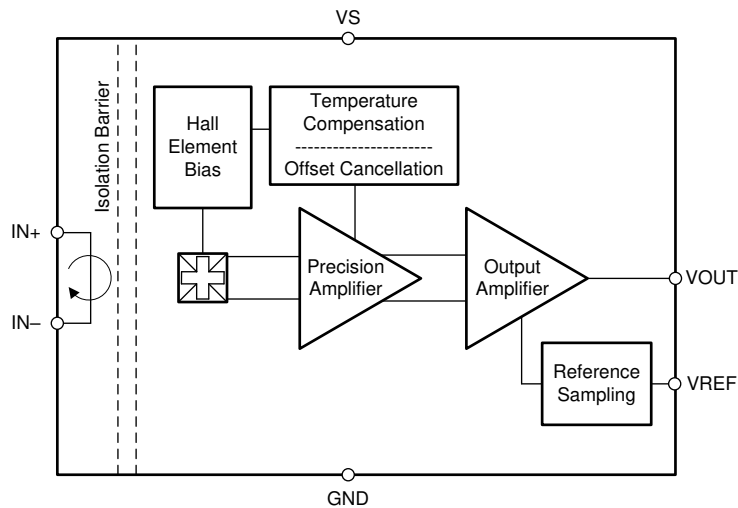

### 2.3.2 LMG3411R050

The LMG341xR050 GaN power stage with integrated driver and protection enables designers to achieve new levels of power density and efficiency in power electronics systems. The inherent advantages of the LMG341x over silicon MOSFETs include ultra-low input and output capacitance, zero reverse recovery to reduce switching losses by as much as 80%, and low switch node ringing to reduce EMI. These advantages enable dense and efficient power conversion.

The LMG341xR050 device provides a smart alternative to traditional cascode GaN and standalone GaN FETs by integrating a unique set of features to simplify design, maximize reliability, and optimize the performance of any power supply. Integrated gate drive enables 100-V/ns switching with near zero  $V_{DS}$  ringing, < 100-ns current limiting self-protects against unintended shoot-through events, overtemperature shutdown prevents thermal runaway, and system interface signals provide self-monitoring capability.

図 3. LMG3411R050 Functional Block Diagram

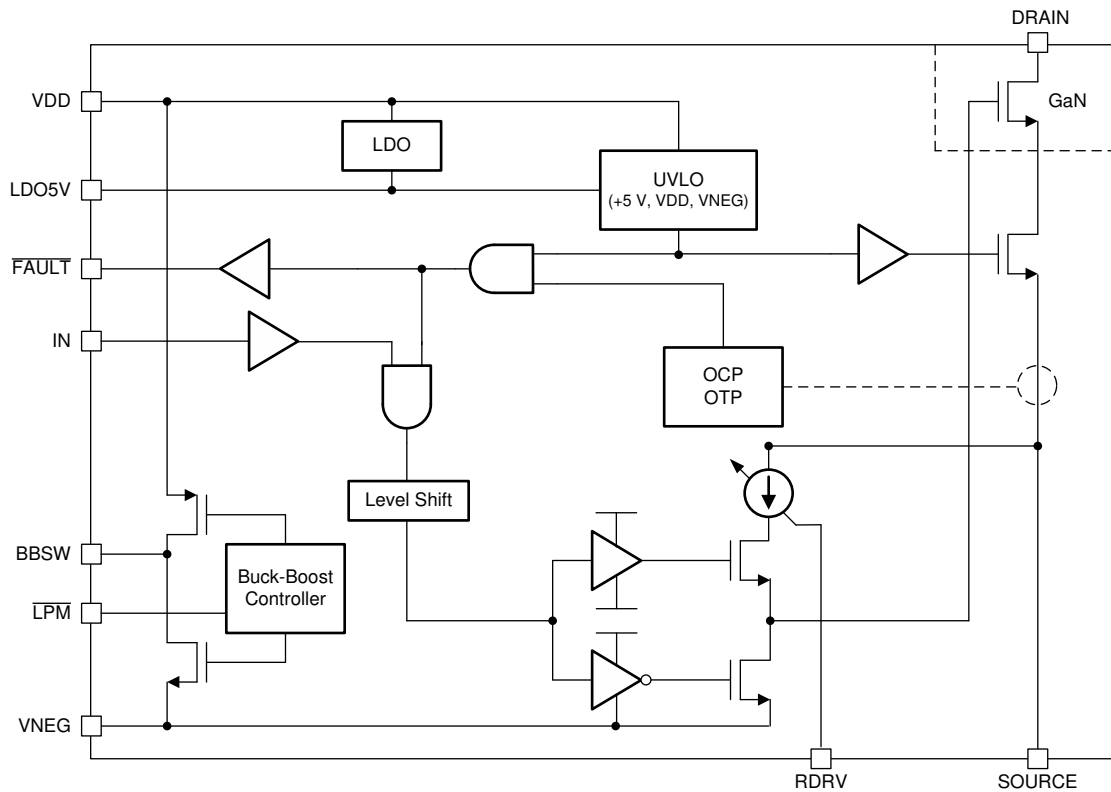

### 2.3.3 ISO7721

The ISO7721x devices are high-performance, dual-channel digital isolators with 3000- $V_{RMS}$  (D package) isolation ratings per UL 1577. These devices are also certified by VDE, TUV, CSA, and CQC.

The ISO7721x devices provide high electromagnetic immunity and low emissions at low power consumption, while isolating CMOS or LVCMOS digital I/Os. Each isolation channel has a logic input and output buffer separated by a double capacitive silicon dioxide ( $SiO_2$ ) insulation barrier. The ISO7721x device has both channels in the opposite direction. In the event of input power or signal loss, the default output is high for devices without suffix F and low for devices with suffix F.



図 4. ISO7721 Functional Block Diagram

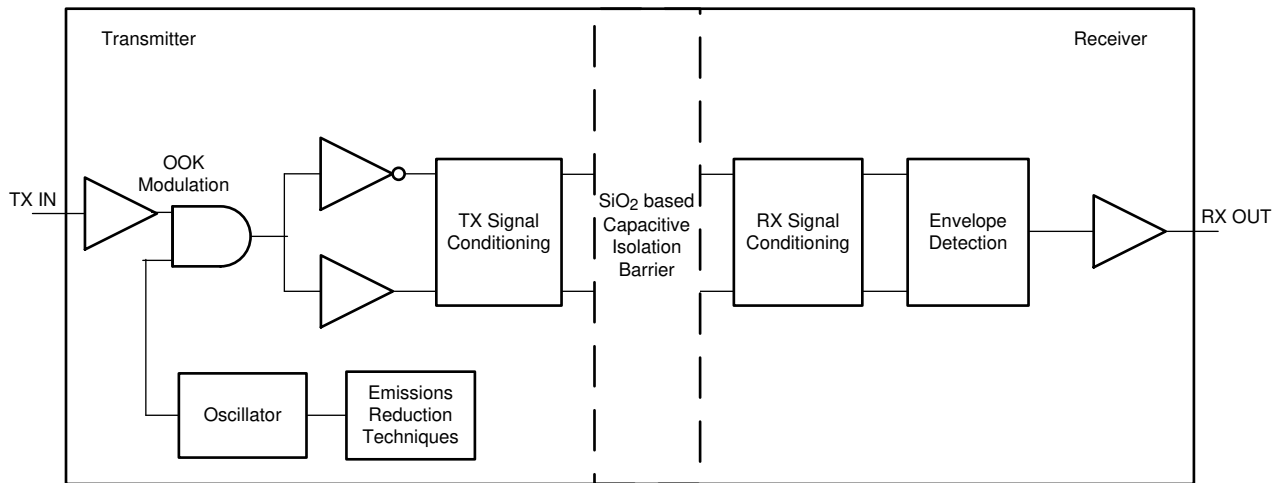

### 2.3.4 REF2030

The REF20xx device offers excellent temperature drift (8 ppm/°C, max) and initial accuracy (0.05%) on both the VREF and VBIAS outputs while operating at a quiescent current less than 430  $\mu$ A. In addition, the VREF and VBIAS outputs track each other with a precision of 6 ppm/°C (max) across the temperature range of -40°C to 85°C. All these features increase the precision of the signal chain and decrease board space, while reducing the cost of the system as compared to a discrete solution. Extremely low dropout voltage of only 10 mV allows operation from very low input voltages, which can be very useful in battery-operated systems.

Both the VREF and VBIAS voltages have the same excellent specifications and can sink and source current equally well. Very good long-term stability and low noise levels make these devices ideally-suited for high-precision industrial applications.

### 2.3.5 TLV9001

The TLV9001 device is a low-voltage (1.8 V to 5.5 V) operational amplifier with rail-to-rail input and output swing capabilities. This op amp provides a cost-effective solution for space-constrained applications where low-voltage operation and high capacitive-load drive are required. The capacitive-load drive of the TLV900x family is 500 pF, and the resistive open-loop output impedance makes stabilization easier with much higher capacitive loads.

The robust design of the TLV900x family simplifies circuit design. The op amps feature unity-gain stability, an integrated RFI and EMI rejection filter, and no-phase reversal in overdrive conditions.

### 2.3.6 TL431

The TL431 and TL432 devices are three-terminal adjustable shunt regulators, with specified thermal stability over applicable automotive, commercial, and military temperature ranges. The output voltage can be set to any value between Vref (approximately 2.5 V) and 36 V, with two external resistors.

The TL431 device is offered in three grades, with initial tolerances (at 25°C) of 0.5%, 1%, and 2%, for the B, A, and standard grade, respectively. In addition, low output drift versus temperature ensures good stability over the entire temperature range.



図 5. TL431 Functional Block Diagram

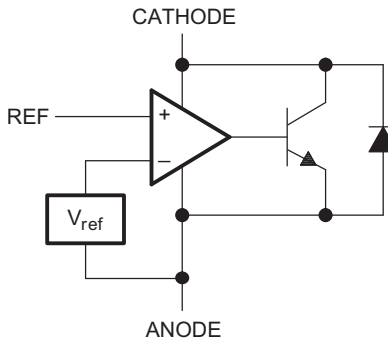

### 2.3.7 TLV1117

The TLV1117 device is a positive low-dropout voltage regulator designed to provide up to 800 mA of output current. The device is available in 1.5-V, 1.8-V, 2.5-V, 3.3-V, 5-V, and adjustable-output voltage options. All internal circuitry is designed to operate down to 1-V input-to-output differential. Dropout voltage is specified at a maximum of 1.3 V at 800 mA, decreasing at lower load currents. The TLV1117 device is designed to be stable with tantalum and aluminum electrolytic output capacitors having an ESR between 0.2 and 10  $\Omega$ . Unlike pnp-type regulators, in which up to 10% of the output current is wasted as quiescent current, the quiescent current of the TLV1117 device flows into the load, increasing efficiency.

## 2.4 System Design Theory

### 2.4.1 Current Sensing

The Hall-effect current sensor, TMCS1100, is used for in-phase, isolated current sensing of all three motor phase currents. The TMCS1100 is available in four gain variants – 50, 100, 200, and 400 mV/A. In this reference design, the 100 mV/A (TMCS1100A2) variant is used. 図 6 shows the current sensing and associated signal processing circuitry.

図 6. Current-Sensing Circuit

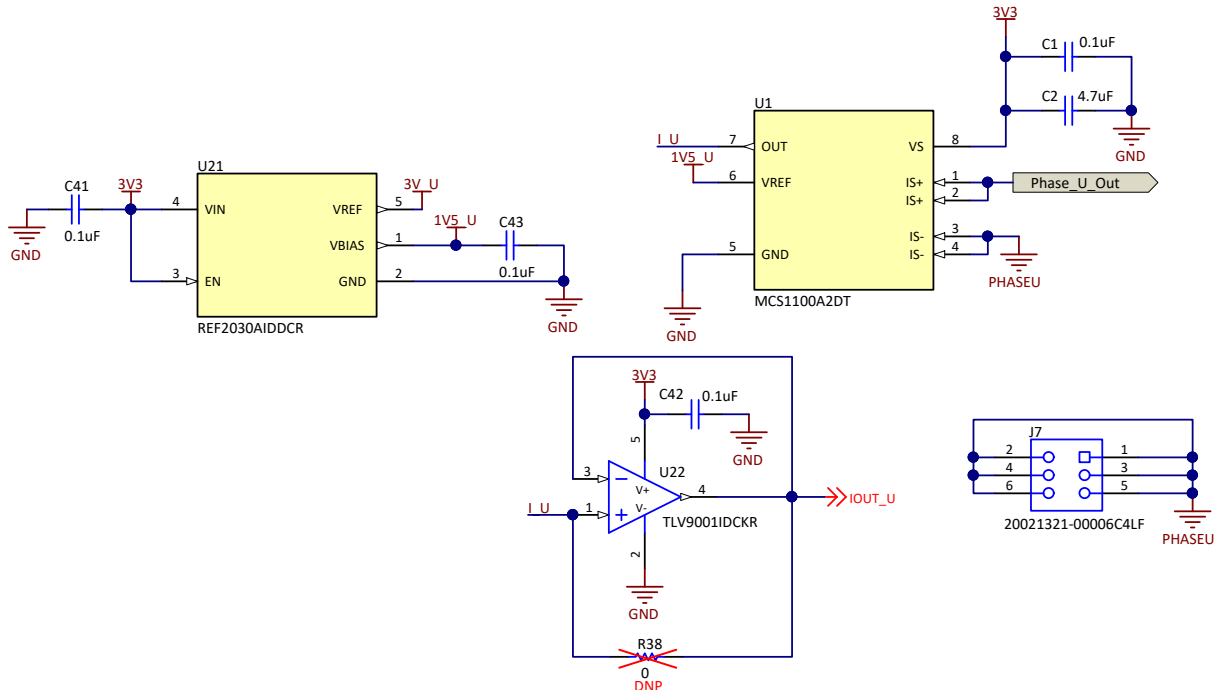

In the TMCS1100, the phase current enters at pins 3 and 4 (marked IS-) and exits at pins 1 and 2 (marked IS+). Therefore, the polarity of the equivalent output voltage (at pin 7) will be inverted with respect to the phase current – this was done for the ease of PCB routing. The TMCS1100 needs an external reference and this is provided using an accurate series voltage reference, REF2030. The external reference is 1.5 V and the output voltage is given by 式 1. In this case, the gain is 100 mV/A and the negative sign accounts for inverse polarity due to current entering at pins 3 and 4 instead of pins 1 and 2.

$$V_{OUT} = V_{REF} - I_{PHASE} \times \text{Gain} \tag{1}$$

The current equivalent voltage signal (I\_U in 図 6) is buffered through an op amp (TLV9001) in voltage follower mode. This is an optional circuit for additional drive strength and can be bypassed, if not necessary, using resistor R38. The current-sensing circuit in 図 6 generates the phase-current equivalent signal (IOUT\_U in 図 6) that is 180° out of phase with the phase current with a positive offset reference of 1.5 V per 式 1. IOUT\_U is transferred to the interface board through the 14-pin connector as 図 10 shows. In 図 7, the interface board has a low-pass R-C filter (R2, C2 in interface board for IOUT\_U) that is used to remove high-frequency noise before transferring the signal to C2000 control card through the 120-pin HSEC8 connector. The filtered current signals are tied to internal ADC input channels for control and monitoring.

図 7. R-C Filter for Removing Noise

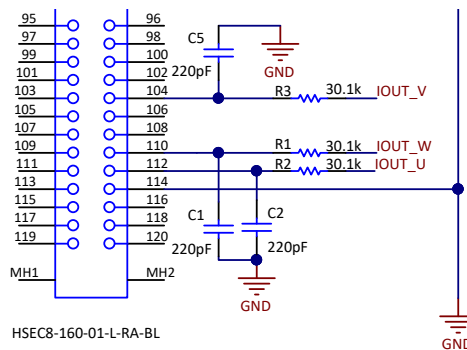

The **TMCS1101** is an alternate part that is pin-to-pin compatible with the **TMCS1100** device but generates an internal reference and does not need an external reference.

### 2.4.2 Three-Phase GaN Inverter Power Stage

The three-phase GaN inverter is realized with six **LMG3411R050** GaN modules. 図 8 shows one half-bridge of the three-phase GaN inverter and the DC link connectors **J4** and **J8** on the power board. Bleeder resistors **R1–R3** are used to discharge the bypass capacitors when DC link power is switched off.

図 8. GaN Inverter Half-Bridge

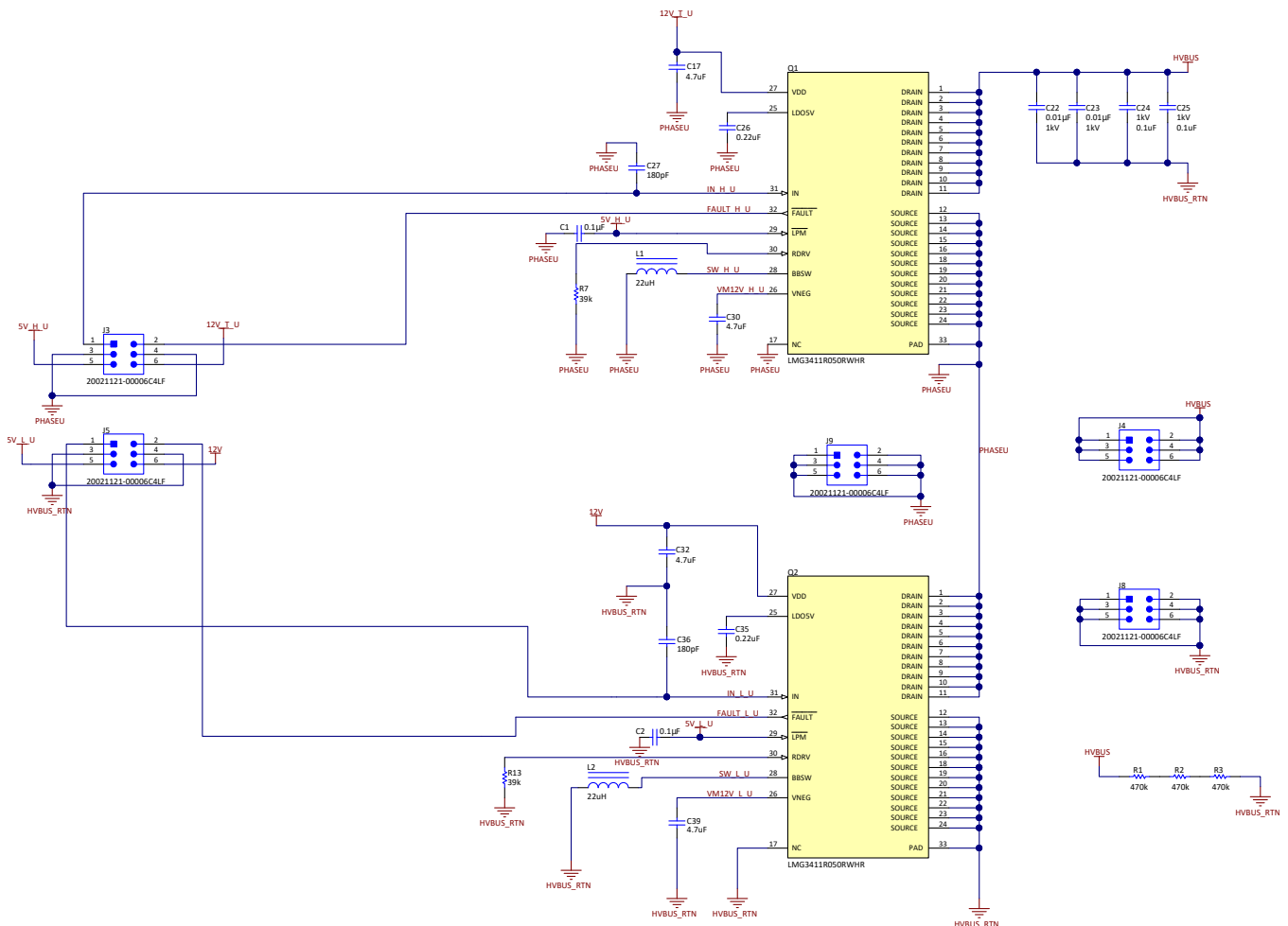

See the *Three-Phase GaN Inverter Power Stage* section of the [Three-phase, 1.25-kW, 200-VAC small form factor GaN inverter reference design for integrated drives](#) design guide for a detailed design theory. The only difference is that the TIDA-00915 reference design uses the 150-mΩ GaN power module (LMG3411R150) that has a 6-A RMS continuous current rating, while the TIDA-010059 reference design uses the 50-mΩ GaN power module (LMG3411R050) that has a 12-A RMS continuous current rating.

### 2.4.3 Low-Voltage Power Rail, 5 V and 3.3 V

An external 5-V bias power supply is required to bias all the circuits on the low-voltage side of the board.  shows the 5-V rail input and the LDO to generate the 3.3-V rail. The diode D1 protects against accidental reverse polarity connection of the 5-V input. The TLV1117 is the LDO used for generating the 3.3-V rail that powers the low-voltage side of the digital isolators (ISO7721F), Hall-effect current sensors (TMCS1100), series voltage references (REF2030) and op amps (TLV9001).

図 9. Power Supply, 3.3 V



表 2 shows the power consumption of all the circuits powered by the 3.3-V rail. There are six digital isolators (ISO7721), three current sensors (TMCS1100), three voltage references (REF2030), three op amps (TLV9001), an indication LED, and GaN fault combination circuitry using AND gates powered from this 3.3-V rail. The current consumption is considered maximum worst case from their respective data sheets. The 2.4 mA for the ISO7721 device is the current consumed on the low-voltage side bias at 3.3 V and for a square waveform with a 1-Mbps transmission rate.

表 2. Current Consumption of 3.3-V Rail Power Supply

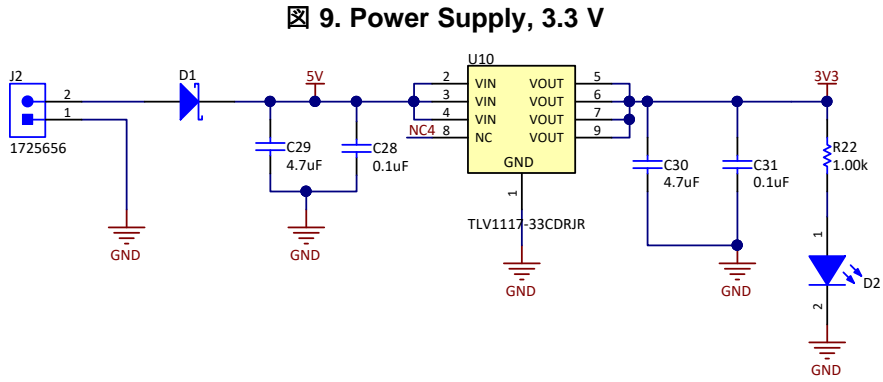
CIRCUITS POWERED FROM 3.3-V LDO	CURRENT
ISO7721 x 6	6 x 2.4 mA
TMCS1100 x 3	3 x 6 mA
REF2030 x 3	3 x 0.46 mA
TLV9001 x 3	3 x 0.085 mA
SN74AHC1G08 x 3	3 x 4 mA
SN74LVC1G11 x 1	16 mA
Indication LED x 1	10 mA

The total worst-case current consumption is about 72 mA. The power dissipation in the LDO is:

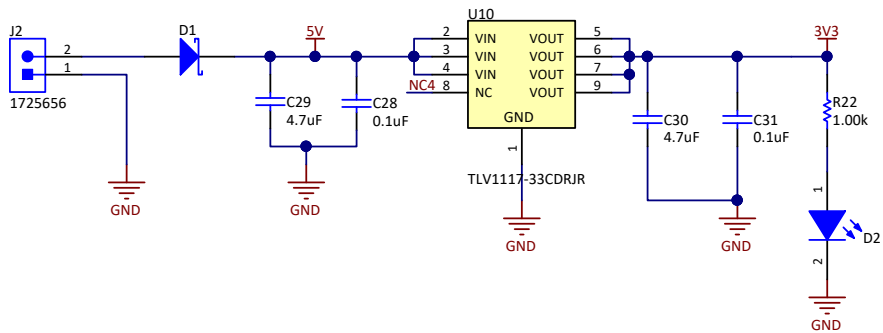
$$P_{LDO} = (V_{IN} - V_{OUT}) \times I_{OUT} = (5 - 3.3) \times 0.072 = 0.122 \text{ W} \quad (2)$$

#### 2.4.4 Connector to Interface Board

A 14-pin connector is used for connecting the current sensing board to the interface board. 10 shows the signals transferred between the interface board and current sensing board - six PWM signals, three phase current signals, one combined GaN fault signal, 5-V power, low-voltage ground. The 5-V transferred from the current sensing board to the interface board is used to power the C2000 control card TMDSCNCD280049C. The 5-V supplied to the C2000 F280049C control card (TMDSCNCD280049C) is stepped down to 3.3-V by an LDO (in TMDSCNCD280049C) to power the C2000 MCU on the control card. The PWM and fault signals are 3.3-V logic signals.

10. Fourteen-pin Connector to Interface Board

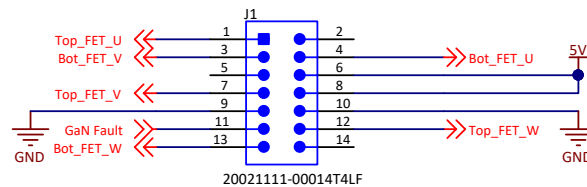

#### 2.4.5 Interface Board

The interface board is an adapter board between the 120-pin C2000 F280049C control card TMDSCNCD280049C and the current sensing board. The interface board allows a small footprint 14-pin connector on the current-sensing board for connecting to the 120-pin control card. Also, the 14-pin connector enables sufficient clearance between the C2000 control card and the high-voltage sections of the current sensing board. The interface board contains the low-pass R-C filter for removing high-frequency noise in the current signals.

### 3 Hardware, Software, Testing Requirements, and Test Results

#### 3.1 Required Hardware and Software

##### 3.1.1 Hardware

##### 3.1.1.1 Power PCB

Figure 11 shows the top and bottom views of the IMS Power PCB of the TIDA-010059 reference design. 6-pin male connectors are used to transfer power and signals between power PCB and current sensing PCB. The locations of the different function connectors are as marked in Figure 11. Nine mounting holes of M2.5 size are provided for making a firm and uniform contact with the heatsink.

Figure 11. TIDA-010059 Power PCB

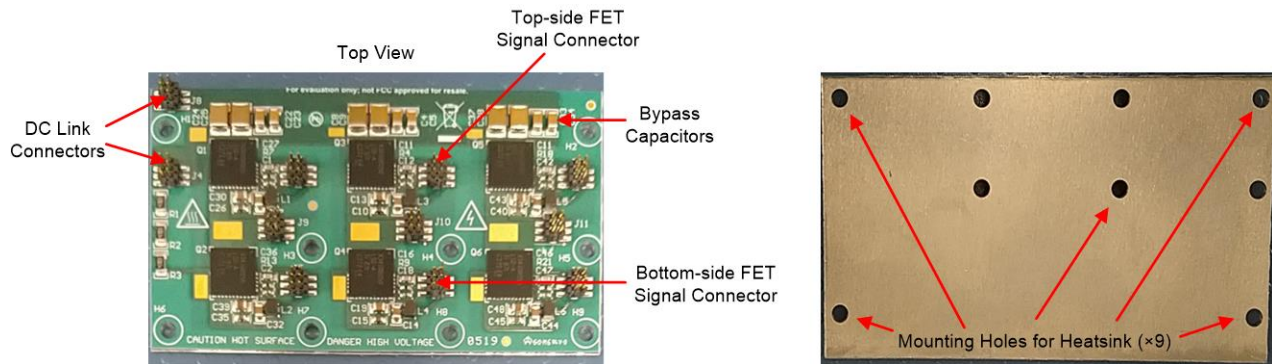

The LPD6080-10B heatsink is used and the thermal interface material (TIM) is HF300P-0.001-00-0404. M2.5 holes are drilled in the heatsink and TIM and mounted onto the PCB using plastic screws (for isolation) as Figure 12 shows. The TIM chosen is phase-change material owing to superior thermal properties at temperatures > 55°C. The thermal impedance of the system can be further reduced by using thermal grease instead of TIM. In an IMS board, the bottom-side aluminum is insulated from electrical circuits on other layers and hence thermal grease can be used instead of TIM.

Figure 12. TIDA-010059 Power PCB Mounted on Heatsink

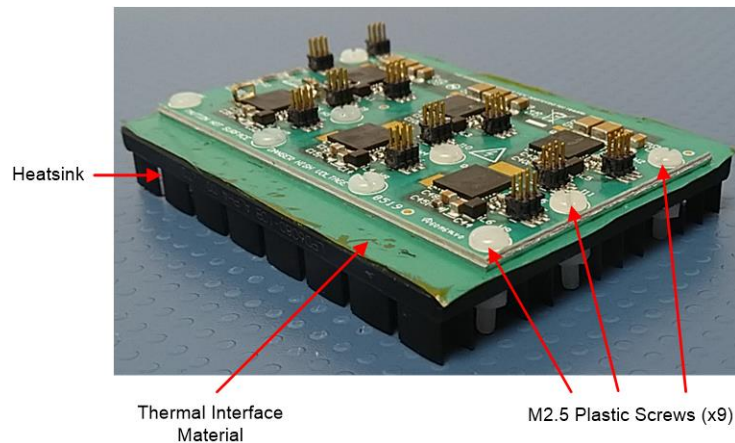

### 3.1.1.2 Current-Sensing PCB

Figure 13 shows the top and bottom views of the current sensing PCB of the TIDA-010059 reference design. All input and output terminals of the TIDA-010059 design are in the current-sensing PCB. The top views show the DC link input, 12-V gate drive power supply, 5-V power supply connectors, the motor terminal connector, and the 14-pin male connector for the interface board for PWM and GaN fault signal. The bottom view shows the 6-pin female connectors that connect with the corresponding male connectors on the power PCB.

Figure 13. TIDA-010059 Current-Sensing PCB

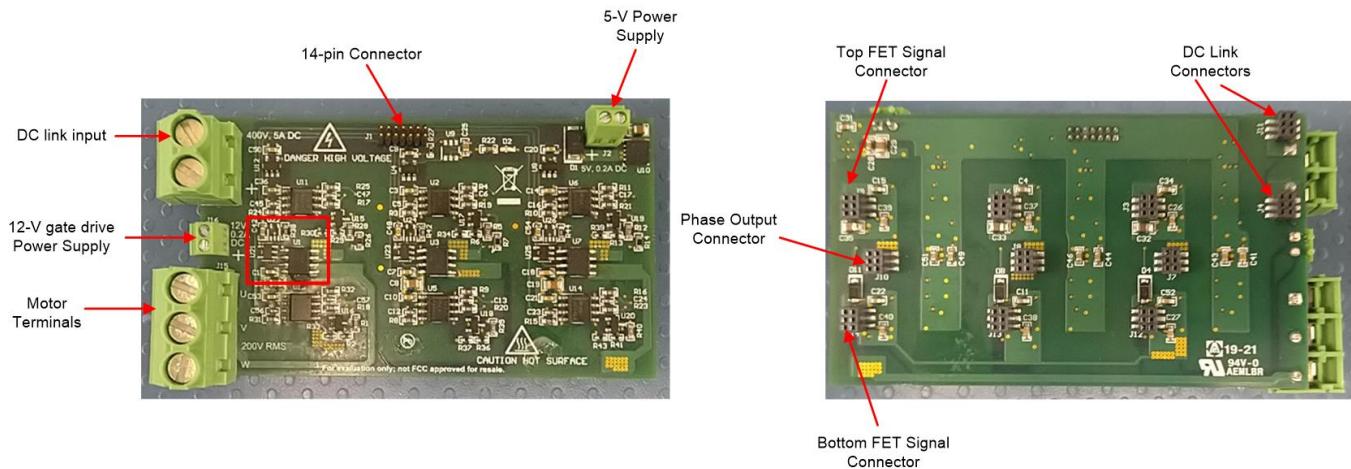

The current-sensing circuit for phase U is shown highlighted within the red box in Figure 13. Each phase has a dedicated current sensor, voltage reference, and buffer op amp for phase current-signal processing. A single-voltage reference can be used for all three phases - dedicated references are used in the TIDA-010059 design for ease of routing.

### 3.1.1.3 Interface PCB and C2000™ Control Card

Figure 14 shows the top and bottom views of the interface PCB and the top view of the C2000 Control Card. The top view of the interface PCB shows the HSEC8 120-pin connector to connect to the C2000 control card at the corresponding HSEC8 120-pin edge. The bottom view shows the 14-pin female connector to connect to the corresponding male connector in the current-sensing PCB. The C2000 control card receives power from the 5-V power supply in the current-sensing PCB via the 14-pin connector - an LDO in the C200 control card converts the 5 V to 3.3 V for C2000 MCU power. The C2000 control card also has an isolated USB to connect to a computer for programming the C2000 MCU.



図 14. TIDA-010059 Interface PCB and C2000™ Control Card

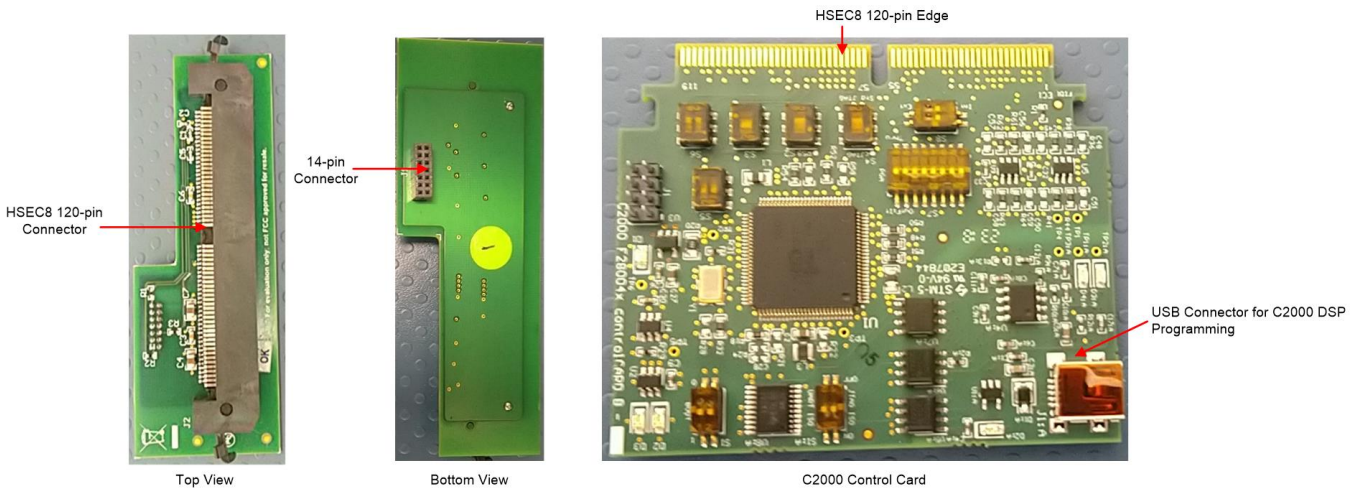

### 3.1.1.4 Assembling the PCBs

図 15 shows the alignment and order of assembling the PCBs. The double-sided arrow indicates the corresponding mating connectors on each PCB. The number indicates the order in which the PCBs connections should be made for ease of assembly.

図 15. Assembling the PCBs



図 16 shows the top and side views of the assembled TIDA-010059 design boards.

図 16. Assembled TIDA-010059

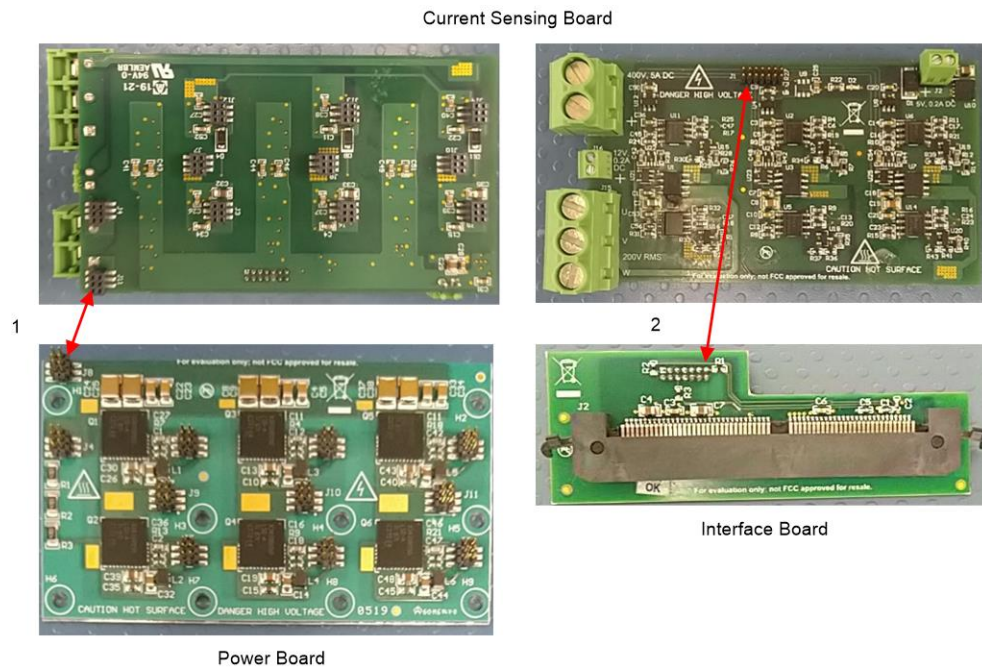
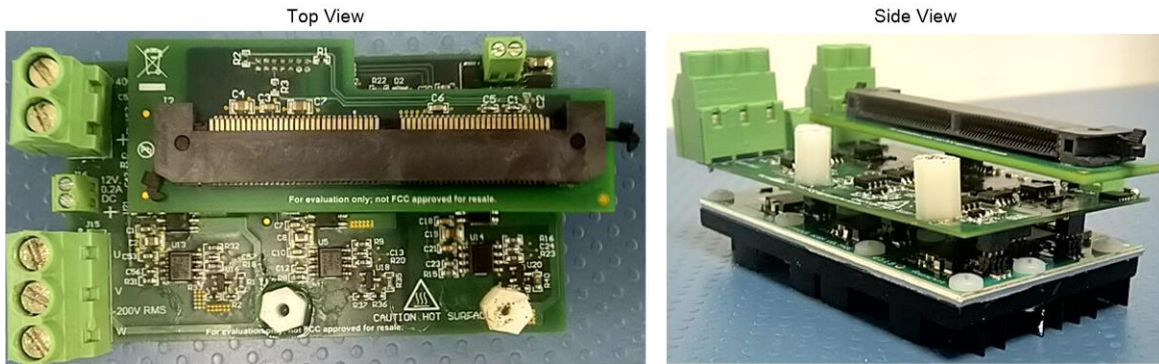

The C2000 control card can be slotted into the HSEC8 120-pin connector on the interface PCB as in 図 17.

図 17. TIDA-010059 With C2000™ Control Card

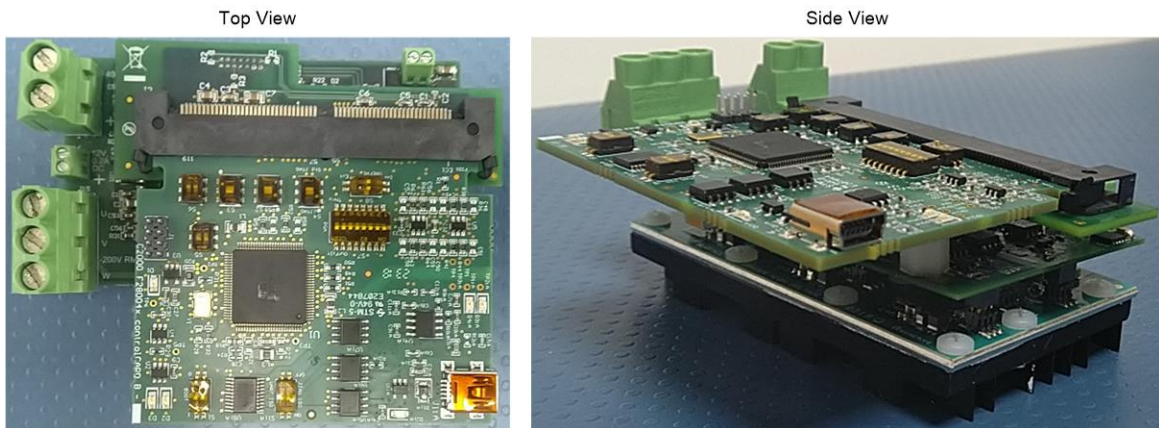

### 3.2 Testing and Results

#### 3.2.1 Test Setup

表 3 lists the key test equipment. The board is powered from three power supplies: 300 V for the DC link, 12 V for the gate-drive power supply, and 5 V for the low-voltage power supply for the MCU, current sensing, logic and low-voltage side of isolation circuits. The 300-V and 12-V power supplies are isolated from the 5-V power supply.

表 3. Key Test Equipment

DESCRIPTION	PART NUMBER
High-speed oscilloscope	Agilent MSO6054A
High-voltage isolated probe	Tektronix P5200A
Passive probe	Agilent 10073C
Isolated current probe	Keysight N2783B
Digital multimeter	Agilent 34401A
Digital multimeter	Fluke 87V
C2000 F280049C control card	Texas Instruments TMDSCNCD280049C
Regulated power supply	Agilent E3631A (x 2)
High-voltage power supply	Sorensen SGI 1000/5
Inverter load	3.7 kW, 1460 rpm (0.5 to 100 Hz), 415 V <sub>RMS</sub> ±10%, η = 83%, cosφ = 0.74 Induction Motor

図 18 shows the TIDA-010059 connections: DC link input, 12-V gate-drive power supply, 5-V power supply for low-voltage bias, motor terminals and an isolated USB connection to the computer for C2000 MCU programming. For the input terminals (DC link, 12 V and 5 V) the red wire denotes positive polarity and the black wire denotes negative polarity.

図 18. TIDA-010059 Test Connections

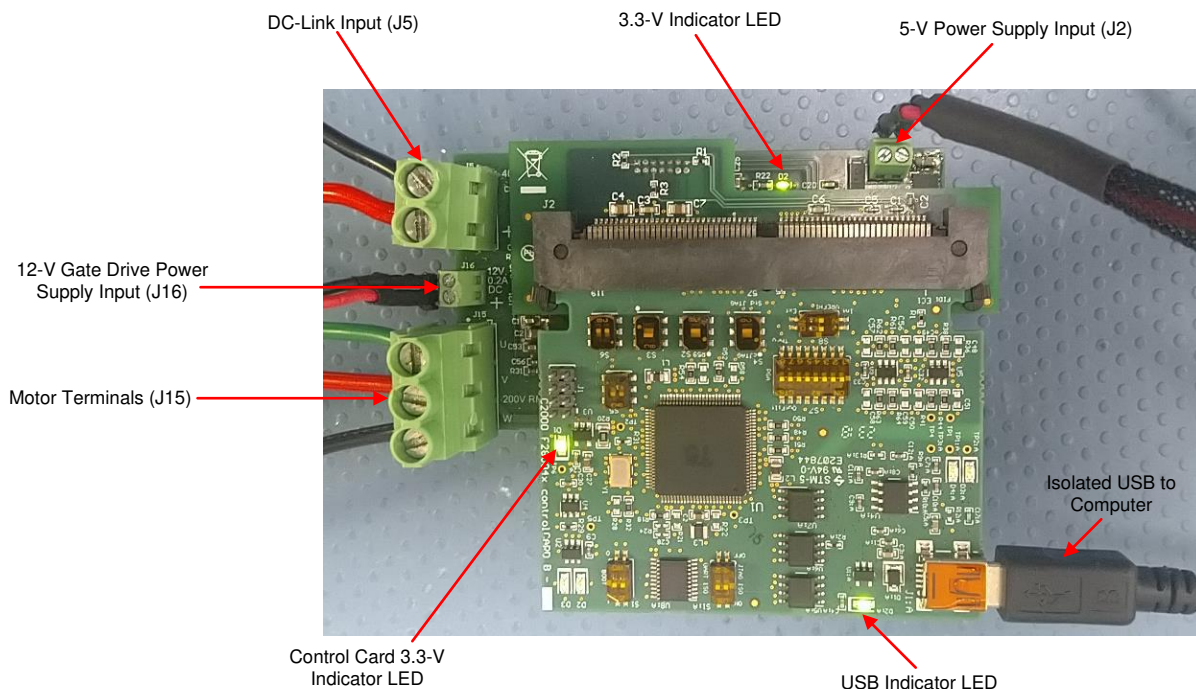



### 3.2.2 Test Results

#### 3.2.2.1 Current Measurement Accuracy

Figure 19 shows the experimental setup to estimate the current measurement accuracy. A switched DC-current (speed reference set to 0 Hz) in the range of  $-6\text{ A}$  to  $+6\text{ A}$  is fed into the motor at different switching frequencies, namely, 16 and 32 kHz at  $25^\circ\text{C}$ . The DC-current reference value is measured using a Fluke 87V digital multimeter and the TMCS1100 output is measured using a 6-1/2 digit Agilent 34401A digital multimeter. This test provides a measure of the ability of the TMCS1100 device to accurately sense the current in the presence of fast-transient switching noise.

Figure 19. Experimental Setup to Estimate the Current Measurement

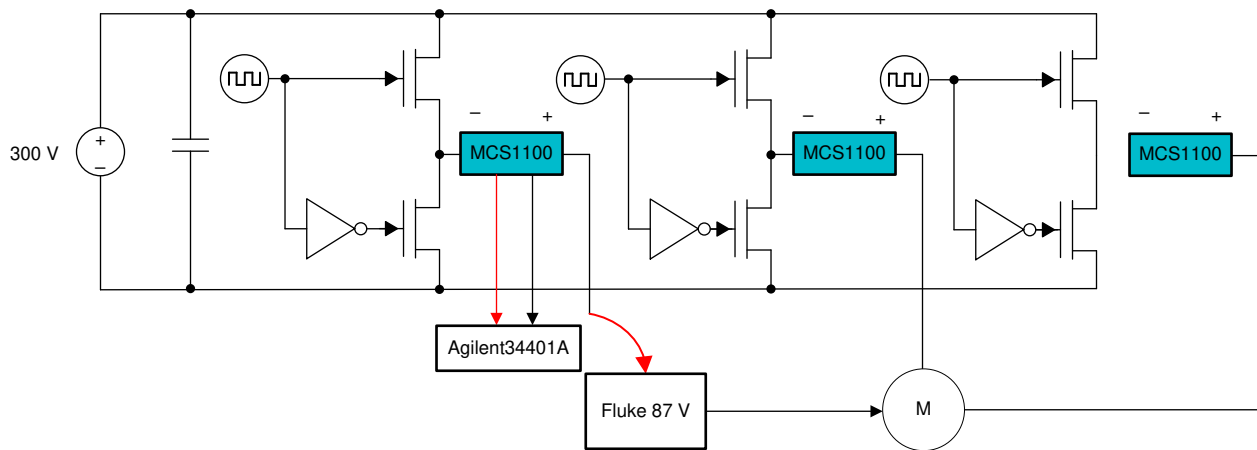

Figure 20 shows the transfer characteristic of TMCS1100. The characteristic has an offset of 1.5 V (external reference to TMCS1100) and is linear across the measured current range.

Figure 20. TMCS1100 Transfer Characteristic

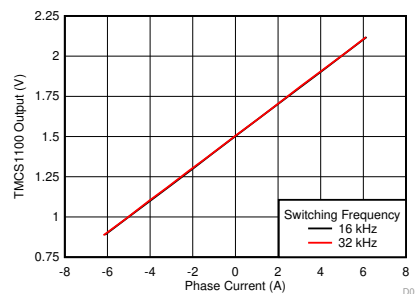

Figure 21 shows the uncalibrated and calibrated Full Scale Range (FSR) Error in % across the measured current range at a switching frequency of 16 kHz. The uncalibrated error is within  $\pm 0.1\%$  and the calibrated error is within  $\pm 0.03\%$ .

図 21. Uncalibrated and Calibrated Full-Scale Range (FSR) Error



図 22 shows that the FSR Error in % across the measured current range at a switching frequency of 32 kHz. The uncalibrated error is within  $\pm 0.2\%$  and the calibrated error is within  $\pm 0.03\%$ .

図 22. FSR Error in % Across the Measured Current Range

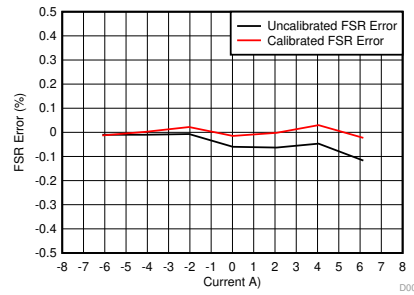
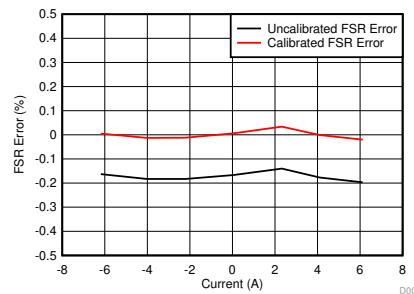

Thus, TMCS1100 enables a highly-accurate current measurement even in the presence of fast-transient switching noise. FSR is taken as 3-V for %FSR error calculation, since the reference voltage is 1.5-V.

### 3.2.2.2 Current Measurement Latency

In current measurement, latency or phase delay plays a critical role in motor position or angle estimation and control loop bandwidth thereby influencing the dynamic performance of the motor drive system. A low-latency current-measurement system enables high-performance and robust motor control.

図 23 shows the experimental setup to estimate the current measurement latency. A three-phase induction motor is operated at different speeds (50 Hz or 60 Hz) and the phase current and TMCS1100 output (post R-C filter) are captured on an oscilloscope.

図 23. Experimental Setup to Estimate the Current Measurement Latency

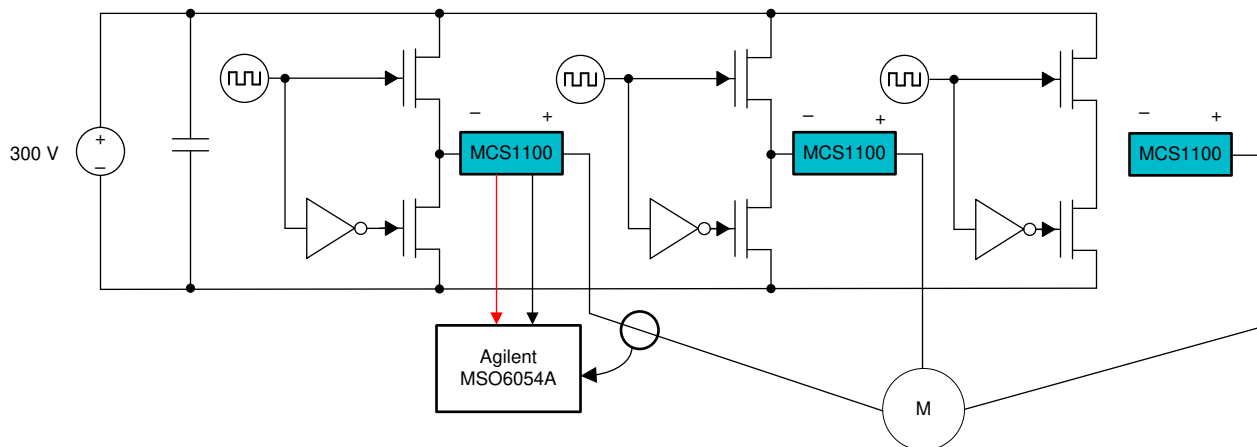

Figure 24 shows the phase relationship between the phase current and the TMCS1100 output along with the RMS measurement accuracy. In Figure 24, the switching noise has been removed by oscilloscope processing - since the processing is uniformly applied to both waveforms, there is no change in the phase delay.

Figure 24. AC Current Response (50 Hz)

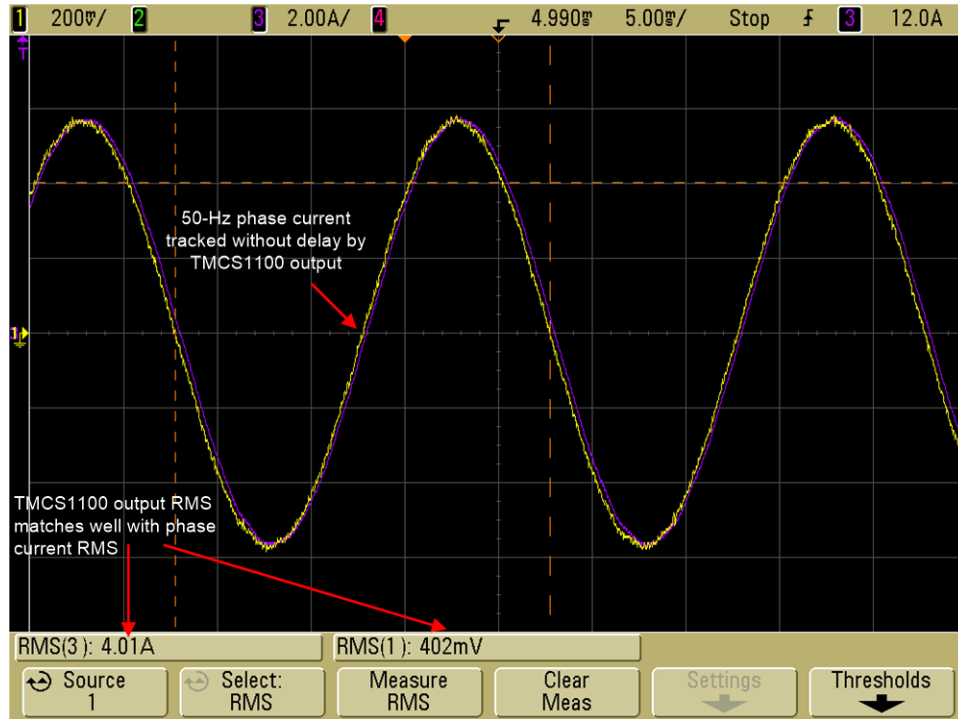
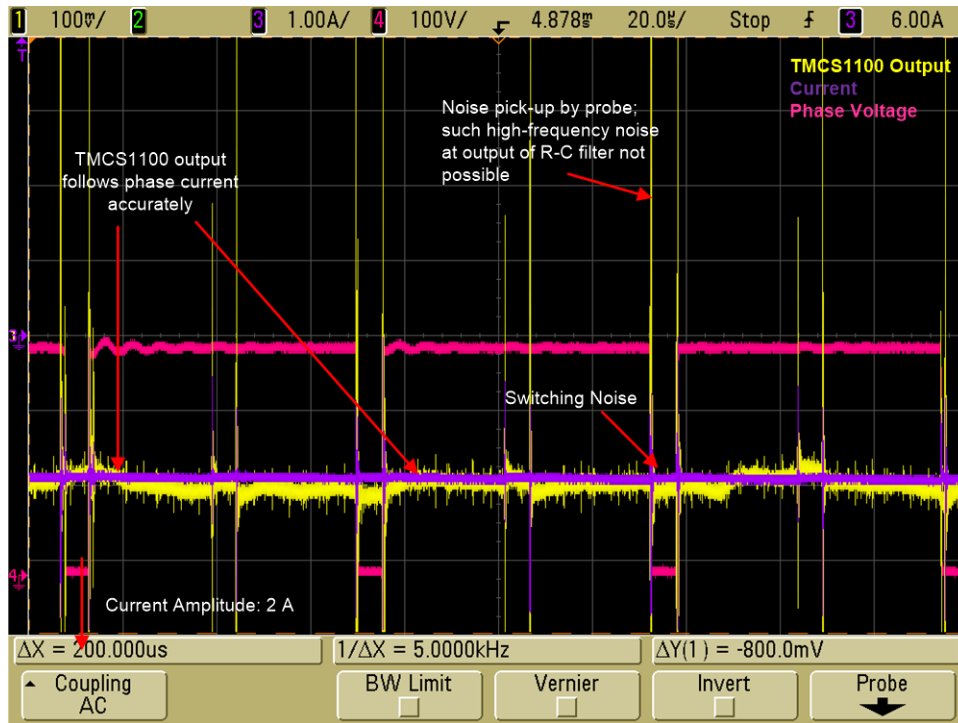

Figure 25 shows the phase current and TMCS1100 output (post R-C filter) within a switching time period in the presence of switching noise. Observe that the TMCS1100 device follows the phase current accurately with negligible delay enabling high-performance control.

図 25. TMCS1100 Output in a Switching Cycle



### 3.2.3 Test Precautions

#### 3.2.3.1 High Voltage (HV)

The TIDA-010059 board works with an HV input of up to 400-V DC. These HV sections are exposed to human contact and hence extreme care must be exercised while testing. The HV areas are marked in the PCB with the text "DANGER HIGH VOLTAGE" and the warning symbol in 図 26. The HV sections are also marked in 図 27 with a dotted red rectangle - users must ensure proper HV safety precautions are observed before and while testing. All exposed terminals (high voltage or otherwise) should **not** be handled directly when power is turned on - all connections must be done only in a powered-down state. 図 27 also shows the voltage, and current ratings of all the power connectors of the TIDA-010059 board.

図 26. High Voltage Warning





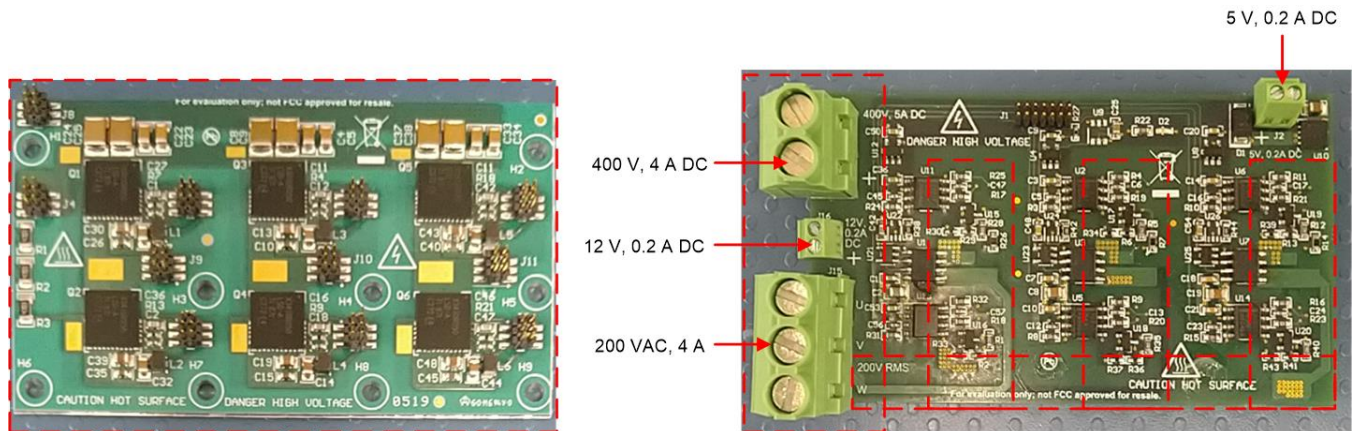

図 27. High Voltage Areas on TIDA-010059



Entire power PCB is high Voltage (400 V DC)

The power supply used to power the DC link, 12-V gate drive power supply, and 5-V bias power need to have suitable current limits set as in 図 27. This is critical to ensure that the TIDA-010059 board is safe from overtemperature and fire hazards in the event of a short-circuit failure.

### 3.2.3.2 High Temperature (HT)

During operation at room temperature (25°C), some components and parts of the PCB surface can reach high temperatures (up to 110°C). Some of these are marked on the PCB with the text "CAUTION HOT SURFACE" and the warning symbol in  28. The high temperature areas are also marked in  29 within the red dotted rectangle.

See the *High Temperature (HT)* section of the [Three-phase, 1.25-kW, 200-VAC small form factor GaN inverter reference design for integrated drives design guide](#) (TIDA-00915) for more information on the high temperature operation of the reference design.

**WARNING**

**Exercise adequate caution during and after testing to avoid burns and other risks linked to high temperature. Also, remember that the components and PCB surface can take a long time (approximately 30 minutes) to cool down to room temperature after shutting down power.**

 28. High Temperature Warning



 29. High Temperature Areas on TIDA-010059

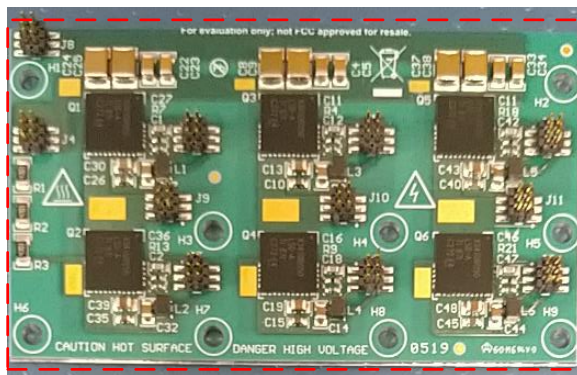

Entire power PCB can get as hot as 110°C

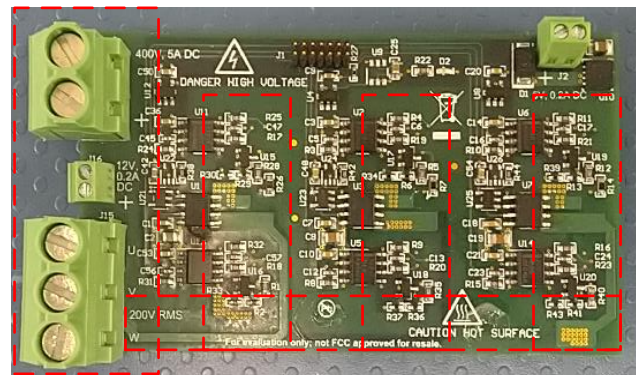

## 4 Design Files

### 4.1 Schematics

To download the schematics, see the design files at [TIDA-010059](#).

### 4.2 Bill of Materials

To download the bill of materials (BOM), see the design files at [TIDA-010059](#).

### 4.3 PCB Layout Recommendations

図 30. TMCS1100 Current Traces, Creepage

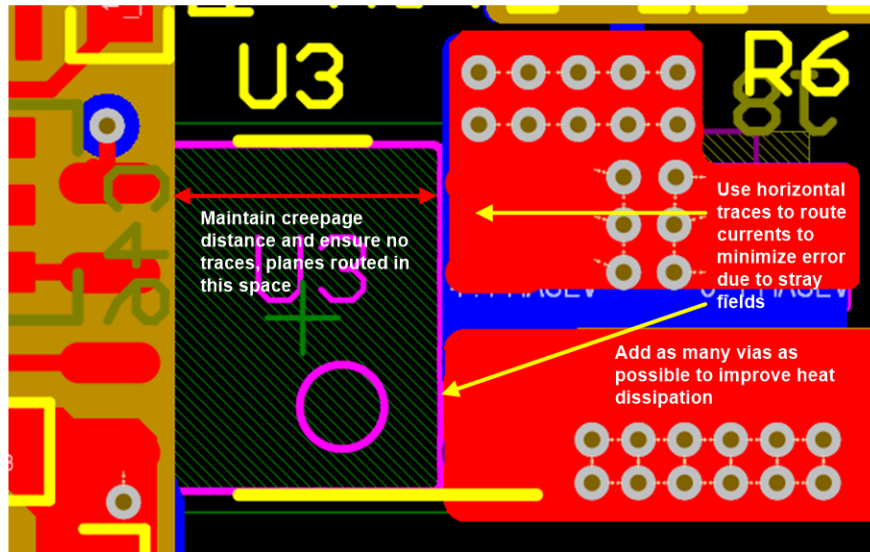

See the [Layout Guidelines](#) section of the [TMCS1100 High-Precision, Isolated Current Sensor With External Reference](#) data sheet for additional layout recommendations to enable better thermal management.

#### 4.3.1 Layout Prints

To download the layer plots, see the design files at [TIDA-010059](#).

### 4.4 Altium Project

To download the Altium Designer® project files, see the design files at [TIDA-010059](#).

### 4.5 Gerber Files

To download the Gerber files, see the design files at [TIDA-010059](#).

### 4.6 Assembly Drawings

To download the assembly drawings, see the design files at [TIDA-010059](#).

## 5 Related Documentation

1. Texas Instruments, [Three-phase, 1.25-kW, 200-VAC small form factor GaN inverter reference design for integrated drives design guide](#)
2. Texas Instruments, [Low-Drift, Precision, In-Line Isolated Magnetic Motor Current Measurements Tech](#)

*Note***5.1 商標**

E2E, C2000 are trademarks of Texas Instruments.  
Altium Designer is a registered trademark of Altium LLC or its affiliated companies.

**6 About the Author**

**SIVABALAN MOHAN** is a Systems Engineer at Texas Instruments, where he is responsible for developing reference designs for motor drives.

## 重要なお知らせと免責事項

TI は、技術データと信頼性データ(データシートを含みます)、設計リソース(リファレンス・デザインを含みます)、アプリケーションや設計に関する各種アドバイス、Web ツール、安全性情報、その他のリソースを、欠陥が存在する可能性のある「現状のまま」提供しており、商品性および特定目的に対する適合性の黙示保証、第三者の知的財産権の非侵害保証を含むいかなる保証も、明示的または黙示的にかかわらず拒否します。

これらのリソースは、TI 製品を使用する設計の経験を積んだ開発者への提供を意図したものです。(1) お客様のアプリケーションに適した TI 製品の選定、(2) お客様のアプリケーションの設計、検証、試験、(3) お客様のアプリケーションが適用される各種規格や、その他のあらゆる安全性、セキュリティ、またはその他の要件を満たしていることを確実にする責任を、お客様のみが単独で負うものとします。上記の各種リソースは、予告なく変更される可能性があります。これらのリソースは、リソースで説明されている TI 製品を使用するアプリケーションの開発の目的でのみ、TI はその使用をお客様に許諾します。これらのリソースに関して、他の目的で複製することや掲載することは禁止されています。TI や第三者の知的財産権のライセンスが付与されている訳ではありません。お客様は、これらのリソースを自身で使用した結果発生するあらゆる申し立て、損害、費用、損失、責任について、TI およびその代理人を完全に補償するものとし、TI は一切の責任を拒否します。

TI の製品は、TI の販売条件 ([www.tij.co.jp/ja-jp/legal/termsofsale.html](http://www.tij.co.jp/ja-jp/legal/termsofsale.html))、または [ti.com](http://ti.com) やかかる TI 製品の関連資料などのいずれかを通じて提供する適用可能な条項の下で提供されています。TI がこれらのリソースを提供することは、適用される TI の保証または他の保証の放棄の拡大や変更を意味するものではありません。

Copyright © 2020, Texas Instruments Incorporated  
日本語版 日本テキサス・インスツルメンツ株式会社

## 重要なお知らせと免責事項

TI は、技術データと信頼性データ(データシートを含みます)、設計リソース(リファレンス・デザインを含みます)、アプリケーションや設計に関する各種アドバイス、Web ツール、安全性情報、その他のリソースを、欠陥が存在する可能性のある「現状のまま」提供しており、商品性および特定目的に対する適合性の黙示保証、第三者の知的財産権の非侵害保証を含むいかなる保証も、明示的または黙示的にかかわらず拒否します。

これらのリソースは、TI 製品を使用する設計の経験を積んだ開発者への提供を意図したものです。(1) お客様のアプリケーションに適した TI 製品の選定、(2) お客様のアプリケーションの設計、検証、試験、(3) お客様のアプリケーションが適用される各種規格や、その他のあらゆる安全性、セキュリティ、またはその他の要件を満たしていることを確実にする責任を、お客様のみが単独で負うものとします。上記の各種リソースは、予告なく変更される可能性があります。これらのリソースは、リソースで説明されている TI 製品を使用するアプリケーションの開発の目的でのみ、TI はその使用をお客様に許諾します。これらのリソースに関して、他の目的で複製することや掲載することは禁止されています。TI や第三者の知的財産権のライセンスが付与されている訳ではありません。お客様は、これらのリソースを自身で使用した結果発生するあらゆる申し立て、損害、費用、損失、責任について、TI およびその代理人を完全に補償するものとし、TI は一切の責任を拒否します。

TI の製品は、TI の販売条件 ([www.tij.co.jp/ja-jp/legal/termsofsale.html](http://www.tij.co.jp/ja-jp/legal/termsofsale.html))、または [ti.com](http://ti.com) やかかる TI 製品の関連資料などのいずれかを通じて提供する適用可能な条項の下で提供されています。TI がこれらのリソースを提供することは、適用される TI の保証または他の保証の放棄の拡大や変更を意味するものではありません。

Copyright © 2020, Texas Instruments Incorporated

日本語版 日本テキサス・インスツルメンツ株式会社