



## ABSTRACT

This user's guide describes the function and use of the PCM1802EVM and PCM1803AEVM. This document includes the hardware configuration instructions, a quick-start guide, jumper and connector descriptions, schematics, and printed-circuit board (PCB) layout that demonstrate TI's recommended practices for these devices.

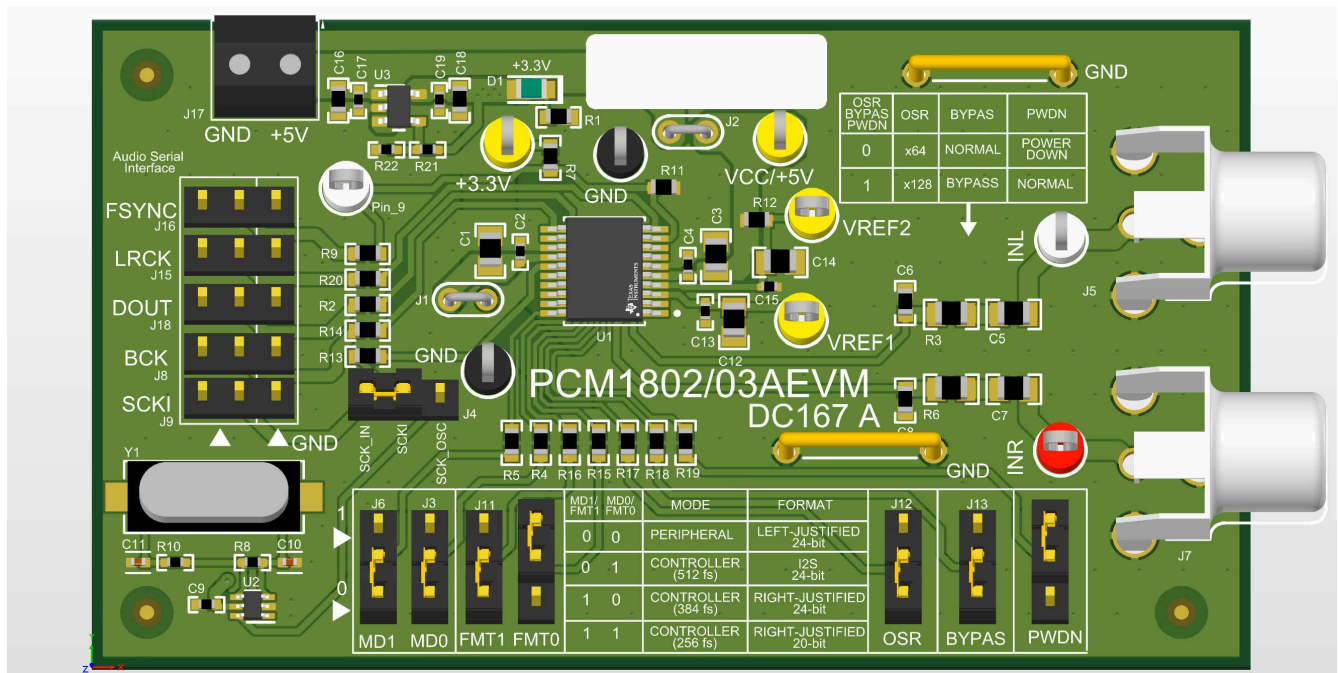

Figure 1-1. PCM1802EVM and PCM1803AEVM

## Table of Contents

<b>1 Trademarks</b> .....	1
<b>2 Introduction</b> .....	2
<b>3 Power Supply</b> .....	2
<b>4 Hardware Configuration</b> .....	3
<b>5 Interfacing With the EVM</b> .....	5
5.1 PCM1802EVM and PCM1803AEVM Inputs.....	5
5.2 PCM1802EVM and PCM1803AEVM Output.....	5
<b>6 Switching Between the PCM1802EVM and PCM1803AEVM</b> .....	5
<b>7 Board Layout</b> .....	6
<b>8 Schematic and Bill of Materials</b> .....	7
8.1 Schematic.....	8
8.2 Bill of Materials.....	10
<b>9 Related Documentation</b> .....	14

## 1 Trademarks

All trademarks are the property of their respective owners.

## 2 Introduction

The PCM1802EVM and PCM1803AEVM are evaluation modules (EVMs) designed to demonstrate the performance and functionality of the PCM1802 and PCM1803A devices, respectively. Although the populated components differ between the two device variants, the PCM1802EVM and PCM1803AEVM use the same hardware and printed circuit board (PCB) layout. The variants are differentiated by the label at the top of the PCB, and by the variant name, DC167-001 (PCM1802EVM) and DC167-002 (PCM1803AEVM), within the manufacturing files.

Both the PCM1802 and PCM1803A are high-performance, low-cost, single-chip, stereo analog-to-digital converters (ADCs) with single-ended analog voltage inputs. The devices are configured through logic-level mode selection pins and do not require a digital interface such as I<sup>2</sup>C or SPI to configure registers. As such, no software is necessary to interface with the EVMs. The EVMs are powered with a single 5-V supply. Access to the converter output is provided on the audio serial interface in I<sup>2</sup>S, right-justified (RJ), and left-justified (LJ) formats.

## 3 Power Supply

The PCM1802EVM and PCM1803AEVM are powered with a single 5-V power supply connected to J17. An onboard low-dropout regulator converts the 5-V supply to the 3.3-V rail used by the ADC. The analog supply, VCC, is fixed at 5 V and the digital supply, VDD, is fixed at 3.3 V. The power status of the EVM is indicated by LED (D1), which illuminates when power is applied to the board.

J1 (VCC, 5 V) and J2 (VDD, 3.3 V) are jumper wires that can be used to disconnect the voltage supply pins (VCC and VDD) of the device from the supply nets (5 V and 3.3 V). This process is done by cutting or unsoldering the wire. These disconnections can help measure the power consumption of each voltage rail using an ammeter or digital multimeter (DMM).

## 4 Hardware Configuration

The audio data format and the ADC operating mode are controlled by the MODE0, MODE1, FMT0, FMT1, OSR, BYPAS, and PWDN pins. These signals are referenced to VDD and can be set to high (1) or low (0). If no shunt is installed, then an internal 50-k $\Omega$  pulldown resistor sets the pin low so that the ADC remains in a defined state. [Table 4-1](#) shows the header numbers and their pin functions and [Table 4-2](#), [Table 4-3](#), [Table 4-4](#), [Table 4-5](#), and [Table 4-6](#) list the possible modes, output formats, and other functions of the device.

MODE0 and MODE1 are used to select the serial audio data communication timing and must be set prior to power on. In controller mode, BCK and LRCK are output pins that are generated by internal divider circuitry from the SCKI input. Thus, SCKI must be a valid multiple of the intended sample rate. The frequency of BCK is constant at 64 BCKs per frame.

In peripheral mode, BCK and LRCK function as input pins. The device accepts either 64-BCKs per frame or 48-BCKs per frame format (only for a 384  $f_s$  system clock), but not a 32-BCK per frame format. Although BCK and LRCK are no longer derived from SCKI in peripheral mode, a valid SCKI is still required for operation.

**Table 4-1. PCM1802EVM and PCM1803AEVM Headers and Jumpers**

Designator	Function
J9	Audio serial interface: system clock input (SCK_IN)
J8	Audio serial interface: bit-clock input or output (BCK)
J15	Audio serial interface: latch-enable input or output (LRCLK)
J18	Audio serial interface: digital data output (DOUT)
J16	PCM1802 only: Frame synchronous clock input and output (FSYNC)
J4	System clock source select (SCKI)
J10	Format [0] select (FMT0)
J11	Format [1] select (FMT1)
J3	Mode [0] select (MODE0 and MD0)
J6	Mode [1] select (MODE1 and MD1)
J12	Oversampling ratio select (OSR)
J13	High-pass filter bypass control select (BYPAS)
J14	Power-down control (nPWDN)
J7	Analog audio input: right
J5	Analog audio input: left
J17	5-V supply input
J1	VDD, 3.3-V jumper wire
J2	VCC, 5-V jumper wire

**Table 4-2. PCM1802 and PCM1803A Mode Settings**

MODE1, MD1	MODE0, MD0	Interface Mode
0	0	Peripheral mode (256 $f_s$ , 384 $f_s$ , 512 $f_s$ , and 768 $f_s$ )
0	1	Controller mode (512 $f_s$ )
1	0	Controller mode (384 $f_s$ )
1	1	Controller mode (256 $f_s$ )

**Table 4-3. PCM1802 and PCM1803A Format Settings**

FMT1	FMT0	Format
0	0	Left-justified, 24-bit
0	1	I <sup>2</sup> S, 24-bit
1	0	Right-justified, 24-bit
1	1	Right-justified, 20-bit

**Table 4-4. PCM1802 and PCM1803A Oversampling Ratio Settings**

OSR	Oversampling Ratio
0	x64
1	x128 ( $f_s < 50$ kHz)

**Table 4-5. PCM1802 and PCM1803A High-Pass Filter Bypass Mode Settings**

BPYAS	High-Pass Filter (HPF) Mode
0	Normal (no DC component on DOUT) mode
1	Bypass (DC component on DOUT) mode

**Table 4-6. PCM1802 and PCM1803A Power-Down Settings**

nPWDN	Mode
0	Power-down mode
1	Normal operation mode

The default jumper locations place the device in peripheral mode and in the I<sup>2</sup>S, 24-bit audio format with x64 oversampling ratio, normal HPF mode, and not in power-down mode. For more information on the operating modes and clock timing of the PCM1802 and PCM1803A device, see the [PCM1802 Single-Ended Analog-Input 24-Bit, 96-kHz Stereo A/D Converter](#) and [PCM1803A Single-Ended, Analog-Input 24-Bit, 96-kHz Stereo A/D Converter](#) data sheets, respectively.

In addition, the SCKI signal can be sourced from an onboard oscillator or provided externally at J9. J4 selects the SCKI clock source (SCK\_OSC) or externally from J9 (SCK\_IN) by changing the position of J4 as shown in [Table 4-7](#).

**Table 4-7. PCM1802EVM and PCM1803AEVM SCK Source Select**

Shunt Position	SCK Source Select
Pins 1-2	SCKI sourced externally through J9 (SCK_IN)
Pins 2-3	SCKI sourced from onboard oscillator (SCK_OSC)

## 5 Interfacing With the EVM

### 5.1 PCM1802EVM and PCM1803AEVM Inputs

The right and left audio inputs to the PCM1802EVM and PCM1803AEVM can be applied through the RCA connectors (J7 and J5, respectively) or directly to the test points (TP4 and TP3, respectively). The single-ended audio inputs pass through an optional antialiasing filter made by R6 and C8 for the right input and R3 and C6 for the left input. The capacitors can be left depopulated and the resistors replaced with 0- $\Omega$  resistors if the filter is not desired.

An input high-pass filter is created by the 4.7- $\mu$ F capacitors (C5 and 79) and 20-k $\Omega$  input impedance for the PCM1802 or 40-k $\Omega$  input impedance for the PCM1803A. This filter structure results in a high-pass filter cutoff frequency of approximately 1.69-Hz and 0.84-Hz for the PCM1802EVM and PCM1803AEVM, respectively.

### 5.2 PCM1802EVM and PCM1803AEVM Output

The digital I/O of the PCM1802EVM and PCM1803AEVM are provided by J8, J9, J15, J16, and J18; the functions are outlined in [Table 4-1](#). The first two pins of each header are duplicated signals to allow for signal input and monitoring. The third pin of each signal is connected to GND.

## 6 Switching Between the PCM1802EVM and PCM1803AEVM

As discussed previously, the populated components differ between the two variants, but the PCM1802EVM and PCM1803AEVM use the same hardware and PCB layout. The variants are differentiated by the label at the top of the PCB, and by the variant name, DC167-001 (PCM1802EVM) and DC167-002 (PCM1803AEVM), within the manufacturing files. As such, a PCM1802EVM can be converted to a PCM1803AEVM and vice versa.

The difference between the two variants is located at pin 9 of U1, which can be either the PCM1802 or PCM1803A. Specifically, all pin functions between the two devices are similar or identical, with the exception of pin 9. Pin 9 functions as FSYNC for the PCM1802, and functions as TEST for the PCM1803A.

Although the FSYNC and TEST details can be reviewed within each device data sheet, the hardware changes are captured in [Section 8.1](#). Specifically, FSYNC is considered part of the audio serial interface (J16), which can be used when R9 is populated, and TEST is a test pin that must be grounded for normal operation, which can be done through R11.

## 7 Board Layout

Figure 7-1 to Figure 7-4 illustrate the EVM board layout.

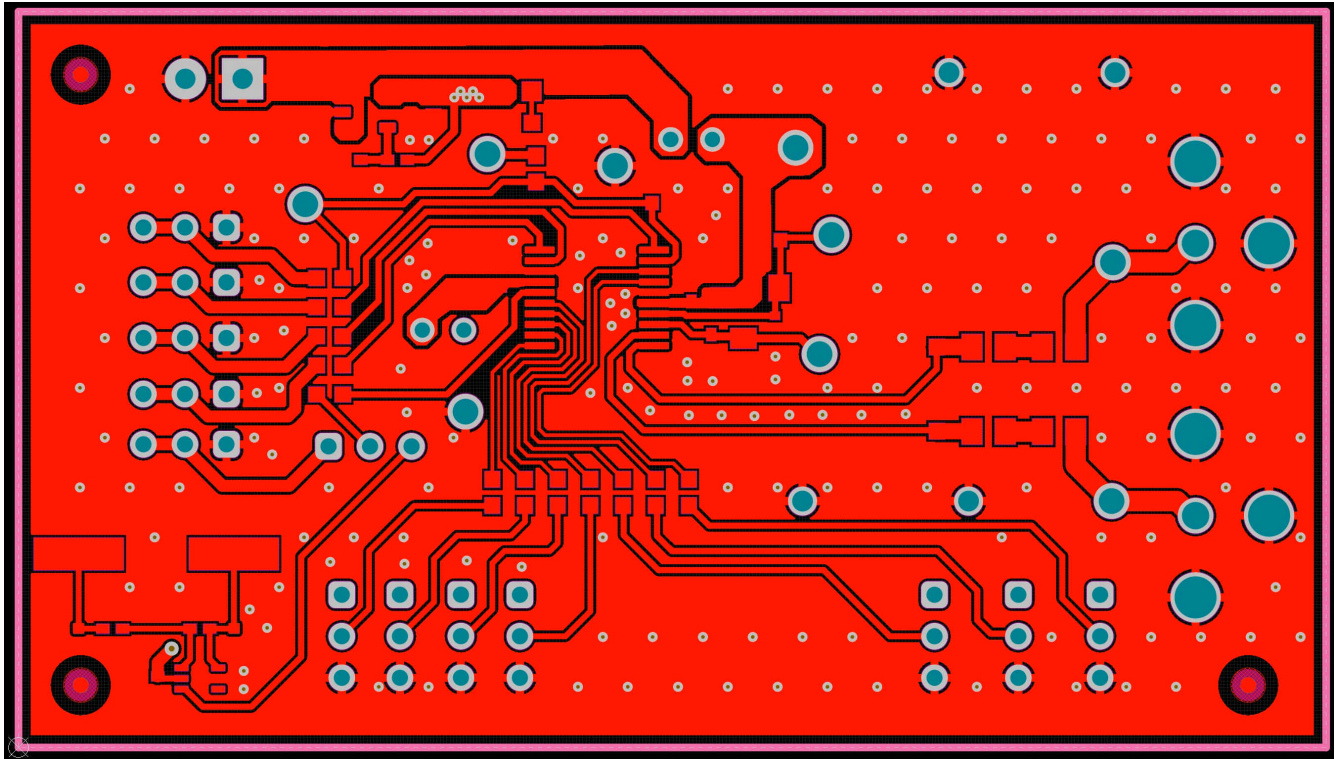

Figure 7-1. PCM1802EVM and PCM1803AEVM Top Layer

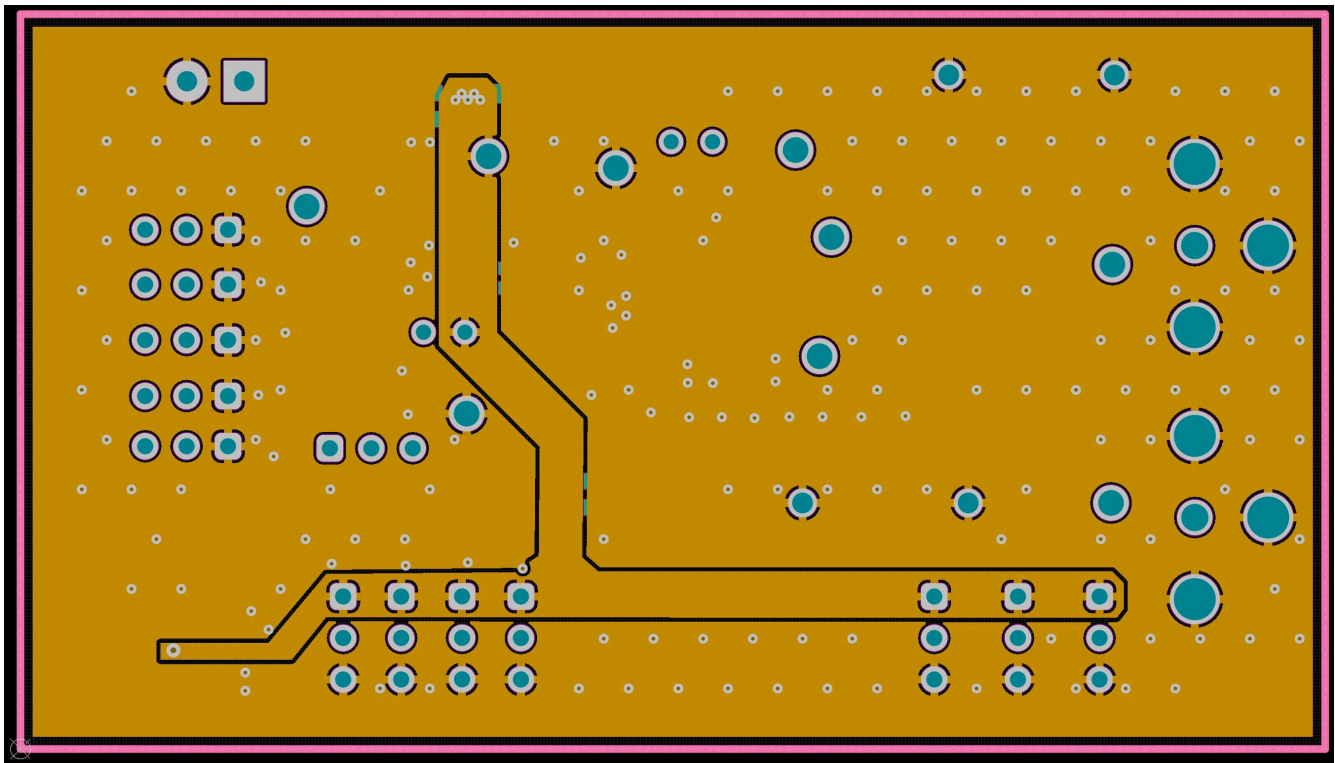

Figure 7-2. PCM1802EVM and PCM1803AEVM Power Plane 1



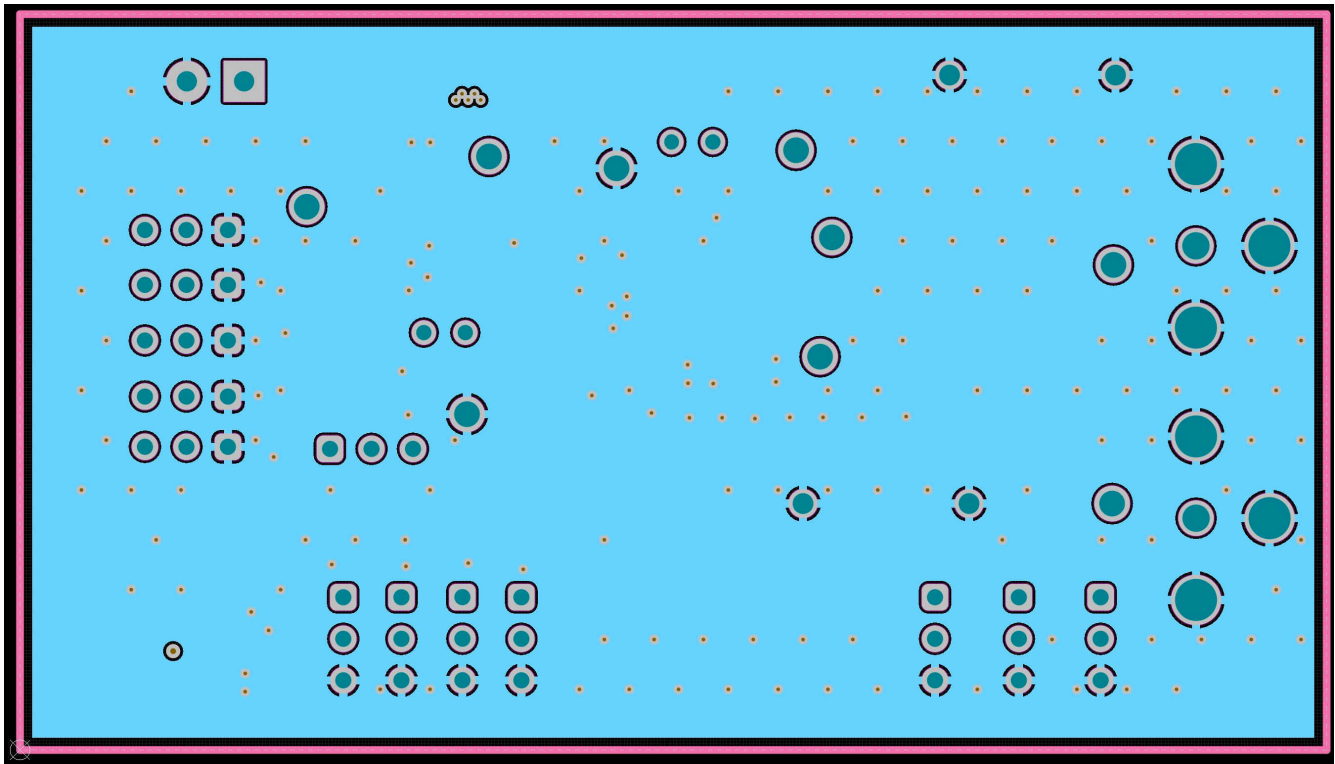

Figure 7-3. PCM1802EVM and PCM1803AEVM Power Plane 2

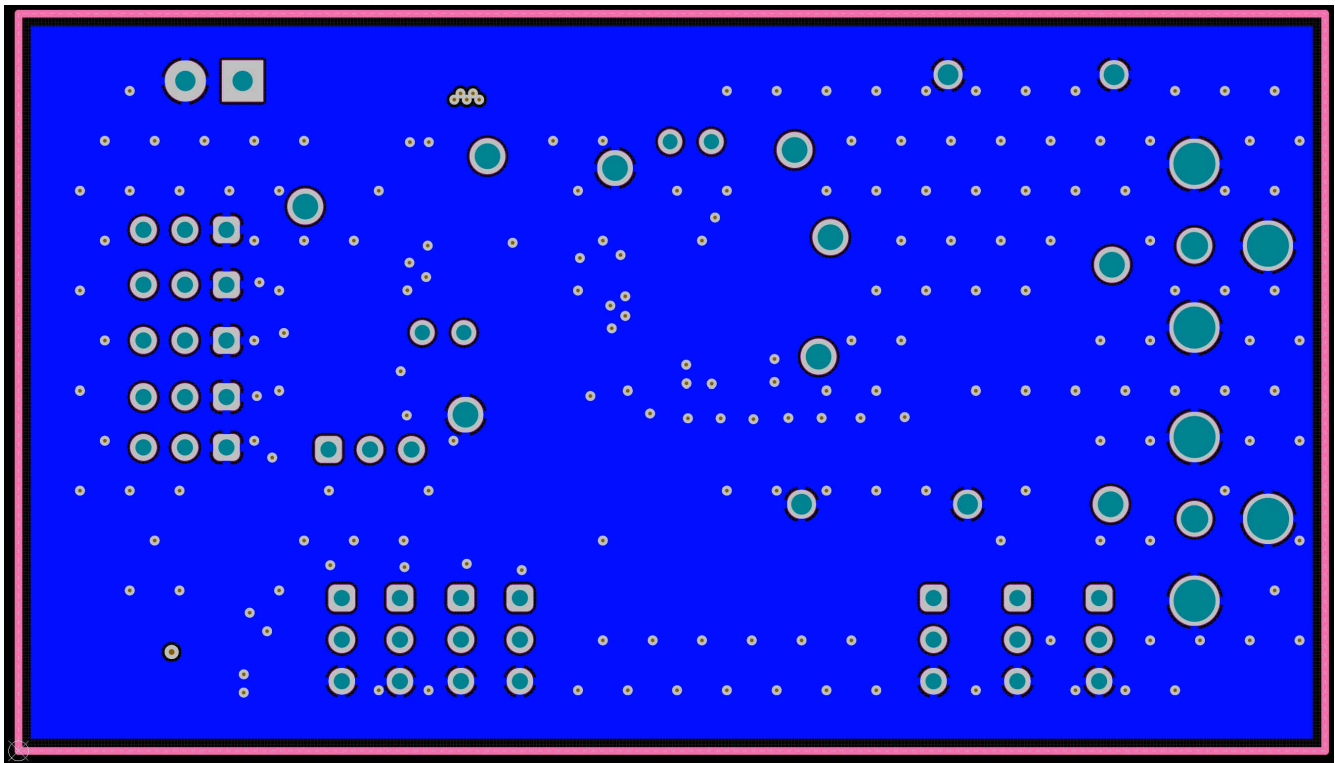

Figure 7-4. PCM1802EVM and PCM1803AEVM Bottom Layer

## 8 Schematic and Bill of Materials

This section contains the EVM schematics and bill of materials.

### 8.1 Schematic

Figure 8-1 and Figure 8-2 illustrate the EVM schematics for the PCM1802EVM and PCM1803AEVM, respectively.

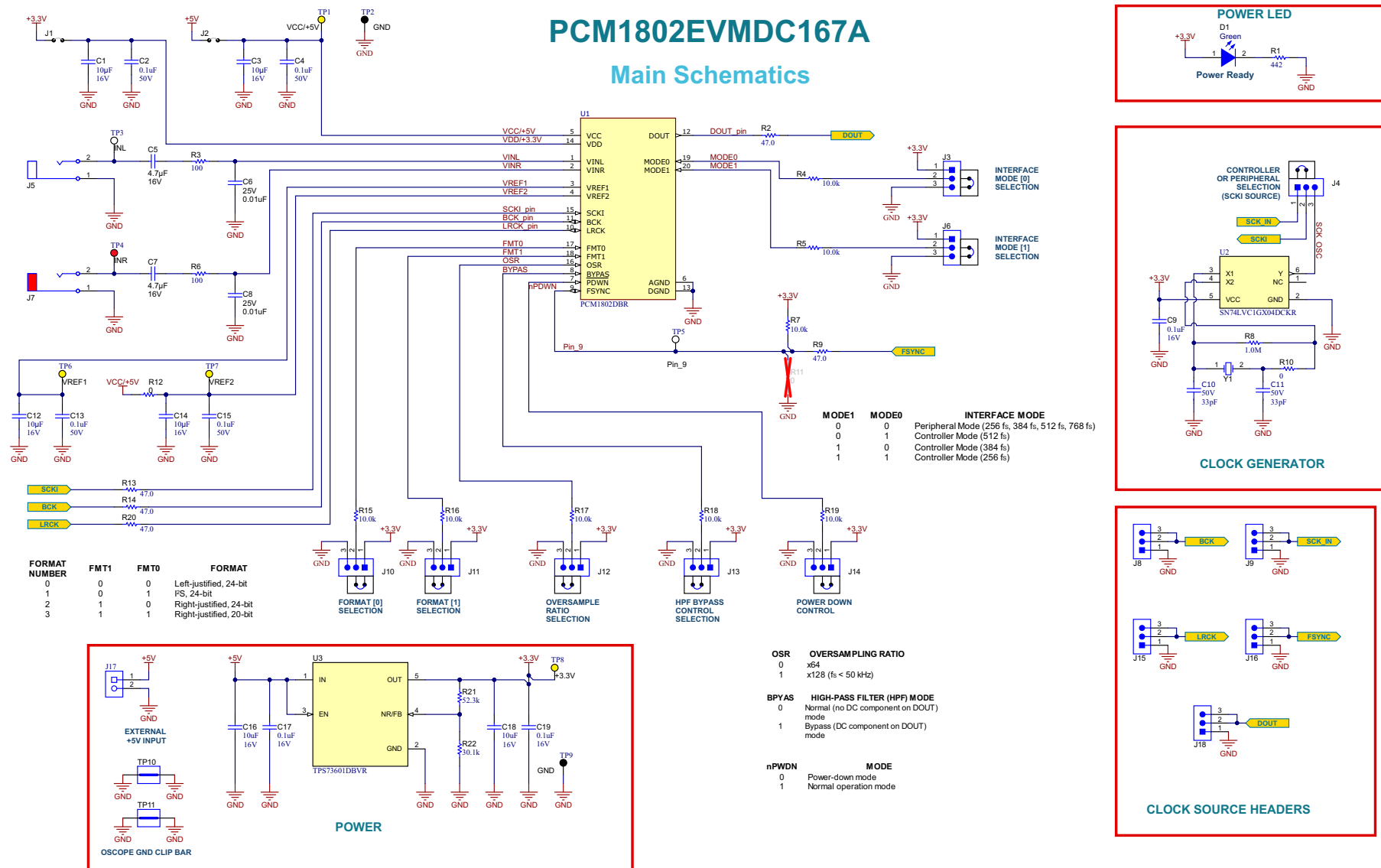

Figure 8-1. PCM1802EVM (DC167-001) Main Schematic Page





## 8.2 Bill of Materials

Table 8-1 and Table 8-2 list the bill of materials (BOM) for the PCM1802EVM and PCM1803AEVM, respectively.

**Table 8-1. PCM1802EVM (DC167-001) Bill of Materials**

Designator	Quantity	Value	Description	Package Reference	Part Number	Manufacturer
!PCB1	1		Printed Circuit Board		DC167	Any
C1, C3, C12, C14	4	10uF	CAP, CERM, 10 uF, 16 V, +/- 10%, X7R, 0805	805	CL21B106KOQNNNE	Samsung Electro-Mechanics
C2, C4, C13, C15	4	0.1uF	CAP, CERM, 0.1 uF, 50 V, +/- 10%, X7R, 0402	402	C1005X7R1H104K050BB	TDK
C5, C7	2	4.7uF	CAP, CERM, 4.7 uF, 16 V, +/- 10%, X7R, AEC-Q200 Grade 1, 0805	805	GCM21BR71C475KA73L	MuRata
C6, C8	2	0.01uF	CAP, CERM, 0.01 uF, 25 V, +/- 5%, C0G/NP0, AEC-Q200 Grade 1, 0603	603	C0603C103J3GCAUTO	Kemet
C9, C17, C19	3	0.1uF	CAP, CERM, 0.1 uF, 16 V, +/- 10%, X7R, 0402	402	GCM155R71C104KA55D	MuRata
C10, C11	2	33pF	Cap Ceramic 33pF 50V C0G ±5% SMD 0402 +125°C Paper T/R	402	CL05C330JB5NNNC	Samsung
C16, C18	2	10uF	CAP, CERM, 10 uF, 16 V, +/- 20%, X5R, 0603	603	GRM188R61C106MAALD	MuRata
D1	1	Green	LED, Green, SMD	LED_0805	LTST-C170KGKT	Lite-On
H1, H2, H3, H4	4		Bumpon, Hemisphere, 0.25 X 0.075, Clear	75x250 mil	SJ5382	3M
J1, J2	2		Jumper Wire, 100mil spacing, pkg of 200, TH	Wire Jumper	923345-01-C	3M
J3, J4, J6, J8, J9, J10, J11, J12, J13, J14, J15, J16, J18	13		Header, 100mil, 3x1, Gold, TH	3x1 Header	TSW-103-07-G-S	Samtec
J5	1		RCA Jack, 1Pos, Tin, White, R/A, TH	RCA Jack, 1Pos, R/A, TH	RCJ-013	CUI Inc.
J7	1		RCA Jack, 1Pos, Tin, Red, R/A, TH	RCA Jack, 1Pos, R/A, TH	RCJ-012	CUI Inc.
J17	1		Terminal Block, 3.5mm Pitch, 2x1, TH	7.0x8.2x6.5mm	ED555/2DS	On-Shore Technology
LBL1	1		Thermal Transfer Printable Labels, 0.650" W x 0.200" H - 10,000 per roll	PCB Label 0.650 x 0.200 inch	THT-14-423-10	Brady
R1	1	442	RES, 442, 1%, 0.1 W, AEC-Q200 Grade 0, 0603	603	CRCW0603442RFKEA	Vishay-Dale
R2, R9, R13, R14, R20	5	47	RES, 47.0, 1%, 0.1 W, 0603	603	RC0603FR-0747RL	Yageo
R3, R6	2	100	RES, 100, 1%, 0.125 W, AEC-Q200 Grade 0, 0805	805	CRCW0805100RFKEA	Vishay-Dale
R4, R5, R7, R15, R16, R17, R18, R19	8	10.0k	RES, 10.0 k, 1%, 0.1 W, AEC-Q200 Grade 0, 0603	603	CRCW060310K0FKEA	Vishay-Dale
R8	1	1.0Meg	RES, 1.0 M, 5%, 0.063 W, AEC-Q200 Grade 0, 0402	402	CRCW04021M00JNED	Vishay-Dale
R10	1	0	RES, 0, 5%, 0.063 W, 0402	402	RC0402JR-070RL	Yageo America
R12	1	0	RES, 0, 5%, 0.1 W, AEC-Q200 Grade 0, 0603	603	ERJ-3GEY0R00V	Panasonic

**Table 8-1. PCM1802EVM (DC167-001) Bill of Materials (continued)**

Designator	Quantity	Value	Description	Package Reference	Part Number	Manufacturer
R21	1	52.3k	RES, 52.3 k, 1%, 0.063 W, AEC-Q200 Grade 0, 0402	402	CRCW040252K3FKED	Vishay-Dale
R22	1	30.1k	RES, 30.1 k, 1%, 0.063 W, AEC-Q200 Grade 0, 0402	402	CRCW040230K1FKED	Vishay-Dale
SH1, SH2, SH3, SH4, SH5, SH6, SH7, SH8	8	1x2	Shunt, 100mil, Gold plated, Black	Shunt	SNT-100-BK-G	Samtec
TP1, TP6, TP7, TP8	4		Test Point, Multipurpose, Yellow, TH	Yellow Multipurpose Testpoint	5014	Keystone
TP2, TP9	2		Test Point, Multipurpose, Black, TH	Black Multipurpose Testpoint	5011	Keystone
TP3, TP5	2		Test Point, Multipurpose, White, TH	White Multipurpose Testpoint	5012	Keystone
TP4	1		Test Point, Multipurpose, Red, TH	Red Multipurpose Testpoint	5010	Keystone
TP10, TP11	2		1mm Uninsulated Shorting Plug, 10.16mm spacing, TH	Shorting Plug, 10.16mm spacing, TH	D3082-05	Harwin
U1	1		IC ADC 24BIT STER 96KHZ 20-SSOP	SSOP20	PCM1802DBR	Texas Instruments
U2	1		Crystal Oscillator Driver, DCK0006A (SOT-SC70-6)	DCK0006A	SN74LVC1GX04DCKR	Texas Instruments
U3	1		Single Output LDO, 400mA, Adj. (1.2 to 5.5V), Cap free, Low Noise, Reverse Current Protection, DBV0005A (SOT-23-5)	DBV0005A	TPS73601DBVR	Texas Instruments
Y1	1		Crystal, 12.288 MHz, 20 pF, SMD	Crystal, 11.4x4.3x3.8mm	ECS-122.8-20-5PX-TR	ECS Inc.
FID1, FID2, FID3	0		Fiducial mark. There is nothing to buy or mount.	N/A	N/A	N/A
R11	0	0	RES, 0, 5%, 0.1 W, AEC-Q200 Grade 0, 0603	603	ERJ-3GEY0R00V	Panasonic

**Table 8-2. PCM1803AEVM (DC167-002) Bill of Materials**

Designator	Quantity	Value	Description	Package Reference	Part Number	Manufacturer
IPCB1	1		Printed Circuit Board		DC167	Any
C1, C3, C12, C14	4	10uF	CAP, CERM, 10 uF, 16 V, +/- 10%, X7R, 0805	805	CL21B106KOQNNNE	Samsung Electro-Mechanics
C2, C4, C13, C15	4	0.1uF	CAP, CERM, 0.1 uF, 50 V, +/- 10%, X7R, 0402	402	C1005X7R1H104K050BB	TDK
C5, C7	2	4.7uF	CAP, CERM, 4.7 uF, 16 V, +/- 10%, X7R, AEC-Q200 Grade 1, 0805	805	GCM21BR71C475KA73L	MuRata
C6, C8	2	0.01uF	CAP, CERM, 0.01 uF, 25 V, +/- 5%, C0G/NP0, AEC-Q200 Grade 1, 0603	603	C0603C103J3GCEAUTO	Kemet
C9, C17, C19	3	0.1uF	CAP, CERM, 0.1 uF, 16 V, +/- 10%, X7R, 0402	402	GCM155R71C104KA55D	MuRata
C10, C11	2	33pF	Cap Ceramic 33pF 50V C0G ±5% SMD 0402 +125°C Paper T/R	402	CL05C330JB5NNNC	Samsung
C16, C18	2	10uF	CAP, CERM, 10 uF, 16 V, +/- 20%, X5R, 0603	603	GRM188R61C106MAALD	MuRata
D1	1	Green	LED, Green, SMD	LED_0805	LTST-C170KGKT	Lite-On
H1, H2, H3, H4	4		Bumpon, Hemisphere, 0.25 X 0.075, Clear	75x250 mil	SJ5382	3M
J1, J2	2		Jumper Wire, 100mil spacing, pkg of 200, TH	Wire Jumper	923345-01-C	3M
J3, J4, J6, J8, J9, J10, J11, J12, J13, J14, J15, J16, J18	13		Header, 100mil, 3x1, Gold, TH	3x1 Header	TSW-103-07-G-S	Samtec
J5	1		RCA Jack, 1Pos, Tin, White, R/A, TH	RCA Jack, 1Pos, R/A, TH	RCJ-013	CUI Inc.
J7	1		RCA Jack, 1Pos, Tin, Red, R/A, TH	RCA Jack, 1Pos, R/A, TH	RCJ-012	CUI Inc.
J17	1		Terminal Block, 3.5mm Pitch, 2x1, TH	7.0x8.2x6.5mm	ED555/2DS	On-Shore Technology
LBL1	1		Thermal Transfer Printable Labels, 0.650" W x 0.200" H - 10,000 per roll	PCB Label 0.650 x 0.200 inch	THT-14-423-10	Brady
R1	1	442	RES, 442, 1%, 0.1 W, AEC-Q200 Grade 0, 0603	603	CRCW0603442RFKEA	Vishay-Dale
R2, R13, R14, R20	4	47	RES, 47.0, 1%, 0.1 W, 0603	603	RC0603FR-0747RL	Yageo
R3, R6	2	100	RES, 100, 1%, 0.125 W, AEC-Q200 Grade 0, 0805	805	CRCW0805100RFKEA	Vishay-Dale
R4, R5, R15, R16, R17, R18, R19	7	10.0k	RES, 10.0 k, 1%, 0.1 W, AEC-Q200 Grade 0, 0603	603	CRCW060310K0FKEA	Vishay-Dale
R8	1	1.0Meg	RES, 1.0 M, 5%, 0.063 W, AEC-Q200 Grade 0, 0402	402	CRCW04021M00JNED	Vishay-Dale
R10	1	0	RES, 0, 5%, 0.063 W, 0402	402	RC0402JR-070RL	Yageo America
R11, R12	2	0	RES, 0, 5%, 0.1 W, AEC-Q200 Grade 0, 0603	603	ERJ-3GEY0R00V	Panasonic
R21	1	52.3k	RES, 52.3 k, 1%, 0.063 W, AEC-Q200 Grade 0, 0402	402	CRCW040252K3FKED	Vishay-Dale

**Table 8-2. PCM1803AEVM (DC167-002) Bill of Materials (continued)**

Designator	Quantity	Value	Description	Package Reference	Part Number	Manufacturer
R22	1	30.1k	RES, 30.1 k, 1%, 0.063 W, AEC-Q200 Grade 0, 0402	402	CRCW040230K1FKED	Vishay-Dale
SH1, SH2, SH3, SH4, SH5, SH6, SH7, SH8	8	1x2	Shunt, 100mil, Gold plated, Black	Shunt	SNT-100-BK-G	Samtec
TP1, TP6, TP7, TP8	4		Test Point, Multipurpose, Yellow, TH	Yellow Multipurpose Testpoint	5014	Keystone
TP2, TP9	2		Test Point, Multipurpose, Black, TH	Black Multipurpose Testpoint	5011	Keystone
TP3, TP5	2		Test Point, Multipurpose, White, TH	White Multipurpose Testpoint	5012	Keystone
TP4	1		Test Point, Multipurpose, Red, TH	Red Multipurpose Testpoint	5010	Keystone
TP10, TP11	2		1mm Uninsulated Shorting Plug, 10.16mm spacing, TH	Shorting Plug, 10.16mm spacing, TH	D3082-05	Harwin
U1	1		IC ADC 24BIT STER 96KHZ 20-SSOP	SSOP20	PCM1803ADBR	Texas Instruments
U2	1		Crystal Oscillator Driver, DCK0006A (SOT-SC70-6)	DCK0006A	SN74LVC1GX04DCKR	Texas Instruments
U3	1		Single Output LDO, 400mA, Adj.(1.2 to 5.5V), Cap free, Low Noise, Reverse Current Protection, DBV0005A (SOT-23-5)	DBV0005A	TPS73601DBVR	Texas Instruments
Y1	1		Crystal, 12.288 MHz, 20 pF, SMD	Crystal, 11.4x4.3x3.8mm	ECS-122.8-20-5PX-TR	ECS Inc.
FID1, FID2, FID3	0		Fiducial mark. There is nothing to buy or mount.	N/A	N/A	N/A
R7	0	10.0k	RES, 10.0 k, 1%, 0.1 W, AEC-Q200 Grade 0, 0603	603	CRCW060310K0FKEA	Vishay-Dale
R9	0	47	RES, 47.0, 1%, 0.1 W, 0603	603	RC0603FR-0747RL	Yageo

## 9 Related Documentation

1. Texas Instruments, [PCM1802 Single-Ended Analog-Input 24-Bit, 96-kHz Stereo A/D Converter data sheet](#)
2. Texas Instruments, [PCM1803A Single-Ended, Analog-Input 24-Bit, 96-kHz Stereo A/D Converter data sheet](#)



## IMPORTANT NOTICE AND DISCLAIMER

TI PROVIDES TECHNICAL AND RELIABILITY DATA (INCLUDING DATA SHEETS), DESIGN RESOURCES (INCLUDING REFERENCE DESIGNS), APPLICATION OR OTHER DESIGN ADVICE, WEB TOOLS, SAFETY INFORMATION, AND OTHER RESOURCES "AS IS" AND WITH ALL FAULTS, AND DISCLAIMS ALL WARRANTIES, EXPRESS AND IMPLIED, INCLUDING WITHOUT LIMITATION ANY IMPLIED WARRANTIES OF MERCHANTABILITY, FITNESS FOR A PARTICULAR PURPOSE OR NON-INFRINGEMENT OF THIRD PARTY INTELLECTUAL PROPERTY RIGHTS.

These resources are intended for skilled developers designing with TI products. You are solely responsible for (1) selecting the appropriate TI products for your application, (2) designing, validating and testing your application, and (3) ensuring your application meets applicable standards, and any other safety, security, regulatory or other requirements.

These resources are subject to change without notice. TI grants you permission to use these resources only for development of an application that uses the TI products described in the resource. Other reproduction and display of these resources is prohibited. No license is granted to any other TI intellectual property right or to any third party intellectual property right. TI disclaims responsibility for, and you will fully indemnify TI and its representatives against, any claims, damages, costs, losses, and liabilities arising out of your use of these resources.

TI's products are provided subject to [TI's Terms of Sale](#) or other applicable terms available either on [ti.com](http://ti.com) or provided in conjunction with such TI products. TI's provision of these resources does not expand or otherwise alter TI's applicable warranties or warranty disclaimers for TI products.

TI objects to and rejects any additional or different terms you may have proposed.

Mailing Address: Texas Instruments, Post Office Box 655303, Dallas, Texas 75265  
Copyright © 2022, Texas Instruments Incorporated