

# Achieving USB Type-C Power Delivery Using TPS56837HA



Lishuang Zhao; Miranda Gu; Andrew Xiong

## ABSTRACT

USB Type-C<sup>®</sup> Power Delivery (PD) is a fast-charging technology based on the USB Type-C standard, which has much greater power transmission capability to charge laptops and other devices, so that it's being implemented widely. When the USB Type-C ports act as source power role, switching regulator needs to provide power over the power conductor ( $V_{BUS}$ ). TI buck device TPS56837HA is defined to support for USB Type-C PD within 100 watts of power, with 4.5V to 28V input range, 4V to 22V output range and 8A current capability.

USB Type-C power delivery and TPS56837HA basic concept and parameters are introduced in this paper. A block diagram using TPS56837HA to realize USB Type-C power delivery is proposed. Two designs using GPIO control and FB control to configure TPS56837HA dynamically output change are demonstrated.

## Table of Contents

<b>1 Introduction</b> .....	2
1.1 USB Type-C Power Delivery Introduction.....	2
1.2 TPS56837HA Introduction.....	2
1.3 Block Diagram of TPS56837HA in USB Type-C Power Delivery Application.....	3
<b>2 PD Controller GPIO to Configure TPS56837HA Dynamically Output Change</b> .....	4
2.1 Typical Application.....	4
2.2 Test Results.....	5
<b>3 PD Controller Dedicated FB Pin to Control TPS56837HA Dynamic Output Change</b> .....	7
3.1 FB Current Injection PD Controller.....	7
3.2 Rfb Integrated PD Controller.....	7
<b>4 Summary</b> .....	8
<b>5 References</b> .....	8

## List of Figures

Figure 1-1. USB Connectors.....	2
Figure 1-2. USB Power Delivery Standards.....	2
Figure 1-3. TPS56837HA in USB Type-C Power Delivery Application Block Diagram.....	3
Figure 2-1. PD Controller GPIO Control for TPS56837HA Dynamically Output Change Reference Schematic.....	4
Figure 2-2. 24Vin-5Vout to 20Vout at 5A (Vout Slew Rate: 13.3V/ms).....	5
Figure 2-3. 24Vin-20Vout to 5Vout at 5A (Vout Slew Rate: 2.9V/ms).....	5
Figure 2-4. TPS56837HA Efficiency Curves.....	5
Figure 2-5. 24Vin-5Vout at 5A (Thermal: 51°C).....	6
Figure 2-6. 24Vin-20Vout at 5A (Thermal: 61°C).....	6
Figure 3-1. PD controller FB Current Injection for TPS56837HA Dynamically Output Change Reference Schematic.....	7
Figure 3-2. Integrated Rfb PD Controller for TPS56837HA Dynamically Output Change Reference Schematic.....	7

## Trademarks

USB Type-C<sup>®</sup> are registered trademarks of USB Implementers Forum.  
All trademarks are the property of their respective owners.

# 1 Introduction

USB Type-C® Power Delivery (PD) is a fast-charging technology based on the USB Type-C standard, which has much greater power transmission capability to charge laptops and other devices, so that is being implemented widely. When the USB Type-C ports act as source power role, switching regulator needs to provide power over the power conductor ( $V_{BUS}$ ). TI buck device TPS56837HA is defined to support for USB Type-C PD within 100 watts of power, with 4.5V to 28V input range, 4V to 22V output range and 8A current capability.

## 1.1 USB Type-C Power Delivery Introduction

USB Type-C is the newly introduced and powerful interconnect standard for USB. When paired with the new Power Delivery (PD) specification, Type-C offers enhancements to the existing USB 3.1 interconnect that lower the cost and simplify the implementation of power delivery over USB.

The USB Type-C connector combines multiple USB connectors – Micro-B, Type-A, and Type-B – in a reversible connector measuring only 2.4mm in height, as shown in [Figure 1-1](#).

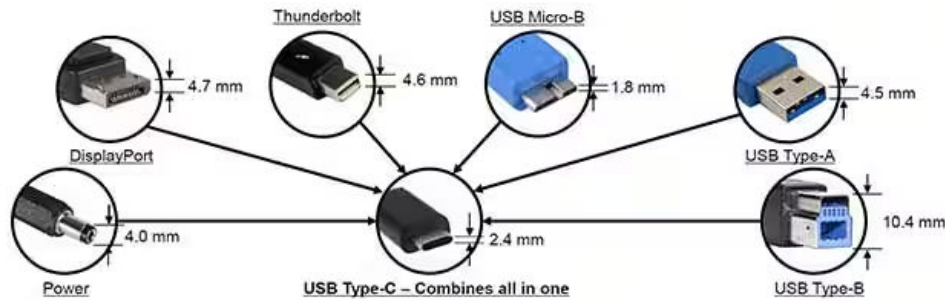

**Figure 1-1. USB Connectors**

With PD specification, the USB Type-C connector can deliver up to 240W. This enables a wider range of applications to operate using USB, as shown in [Figure 1-2](#).

USB protocol	Nominal voltage	Maximum current	Power
USB Type-C	5 V	3 A	15 W
USB PD 3.0	Configurable up to 20 V	5 A	Up to 100 W
USB PD 3.1	Configurable up to 48 V	5 A	Up to 240 W

**Figure 1-2. USB Power Delivery Standards**

## 1.2 TPS56837HA Introduction

The TPS56837HA is a high-efficiency, easy-to-use, synchronous buck converter with a wide input voltage range of 4.5V to 28V. The device supports up to 8A continuous output current at output voltages between 4V and 22V, and supports 5V, 9V, 15V, 20V dynamically output change with available current 3A and 5A for USB Type-C PD application.

The TPS56837HA operates at Eco-mode to attain high efficiency at light load with fixed 500kHz switching frequency.

The TPS56837HA has three selectable current limits through MODE pin configuration, as shown in [Table 1-1](#). TPS56837HA is designed to fulfill peak current 200% overload capabilities for available current 3A as well as 5A. Details can check fixed power source peak current capability table in PD specification.

**Table 1-1. TPS56837HA Current Limits**

CURRENT LIMIT						
I <sub>LS_OCL</sub>	Low-side MOSFET valley current limit	ILIM-1 option	6	7.2	8.5	A
		ILIM option	8	9.6	11.1	
		ILIM+1 option	10	12	13.8	

The TPS56837HA has adjustable soft-start time by the SS pin capacitor configuration. The TPS56837HA provides complete non-latched OV (overvoltage), UV (undervoltage), OC (overcurrent), OT (overtemperature), and UVLO (undervoltage lockout) protections combined with power-good indicator.

The TPS56837HA is available in a 10-pin, 3.0mm × 3.0mm, HotRod QFN package, and the junction temperature is specified from –40°C to 150°C.

### 1.3 Block Diagram of TPS56837HA in USB Type-C Power Delivery Application

Figure 1-3 shows the block diagram of using TPS56837HA with PD controller to implement USB Type-C power design.

- **AC/DC output or Vin:** the AC/DC output or Vin can be fixed voltage or can be controlled by PD controller to output needed voltage.
- **Bypass:** PD controller can control the bypass on or off to directly bypass input to output so as to improve whole system efficiency.

To avoid the output discharge causing power loss during bypass application, TPS56837HA does not support output discharge feature. This is the only difference between TPS56837HA and TPS56837H (support output discharge).

- **TPS56837HA and PD controller:**
  - **GPIO control output dynamically change:** using PD controller GPIO signal to switch DC/DC feedback resistor configuration to dynamically change output voltage. Section 2 introduces the schematic and bench test results.
  - **FB control output dynamically change:** this design require PD controller has the ability to control DC/DC FB feature, for example, the PD controller has dedicated FB pin which can connect to DC/DC FB pin to dynamically change output voltage with PD firmware.
  - The following chapter introduces the details.

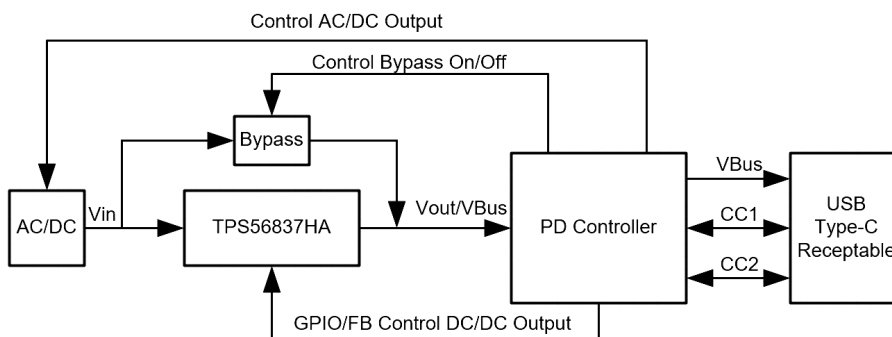
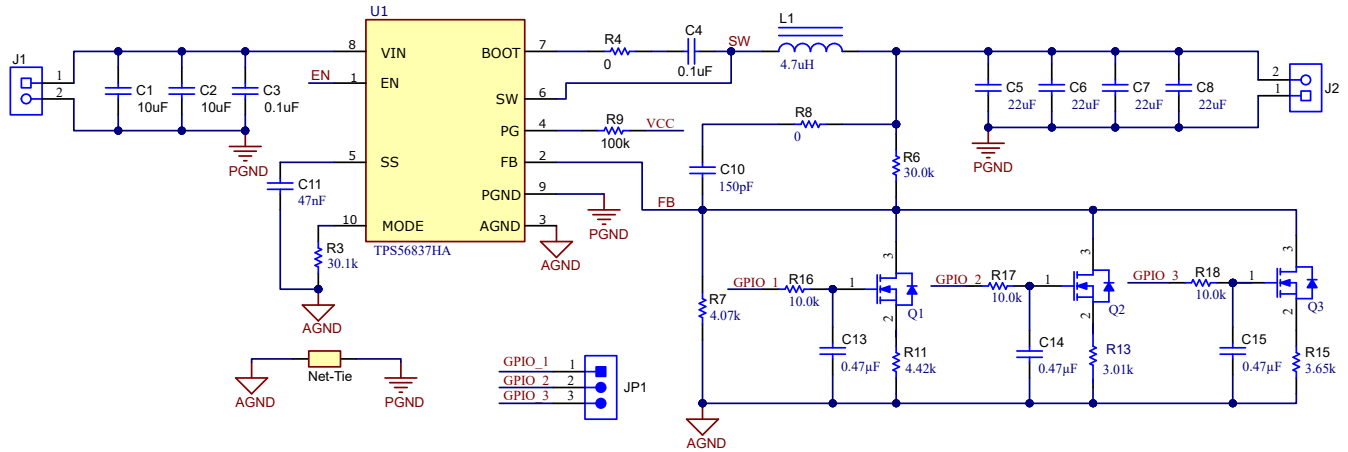

**Figure 1-3. TPS56837HA in USB Type-C Power Delivery Application Block Diagram**

## 2 PD Controller GPIO to Configure TPS56837HA Dynamically Output Change

### 2.1 Typical Application

The typical application schematic in [Figure 2-1](#) shows using GPIO to switch TPS56837HA feedback bottom resistor to dynamically change output voltage.



**Figure 2-1. PD Controller GPIO Control for TPS56837HA Dynamically Output Change Reference Schematic**

[Table 2-1](#) shows GPIO configuration logic for different output voltage.

- When all GPIO signal is low, no switch is open, the output is configured by R6 and R7 to default 5V.
- When GPIO1 is changed from low to high, Q1 switch is conducted, the output is configured by R6 and R7 parallel R11 changed from 5V to 9V. Other scenario is the same mechanism.

**Table 2-1. GPIO Configuration Logic**

GPIO_1	GPIO_2	GPIO_3	Vout_set/V	Rfb_top/ohm	Rfb_bot/ohm	Vout/V
0	0	0	5	30k	4.07k	5.02
1	0	0	9	30k	2.119k	9.10
1	1	0	15	30k	1.244k	15.08
1	1	1	20	30k	0.928k	20.01

The switch Q1, Q2 and Q3 gate RC filters are used to regulate the GPIO edge slew rate so that the output voltage changing slew rate can meet PD3.1 specifications of voltage transitions  $v_{SrcSlew}$ .

The application BOM selection guide can refer to the detailed design procedure in [TPS56837Hx 4.5V to 28V Input, 8A, Synchronous Buck Converter](#), data sheet.

## 2.2 Test Results

This section provides typical performance waveforms based on [Section 2.1](#) application circuit. All the results are tested on 70mm x 70mm 2-1-1-2 oz evaluation board with appendix BOM. Actual performance data is affected by measurement techniques and environmental variables; therefore, these curves are presented for reference and can differ from actual results obtained.

### 2.2.1 Dynamically Change Waveforms

[Figure 2-2](#) and [Figure 2-3](#) show output voltage changes from 5Vout to 20Vout / 20Vout to 5Vout at 24Vin 5A, respectively. Results indicate output transitions are smooth and transition slew rate are within 30mV/us.

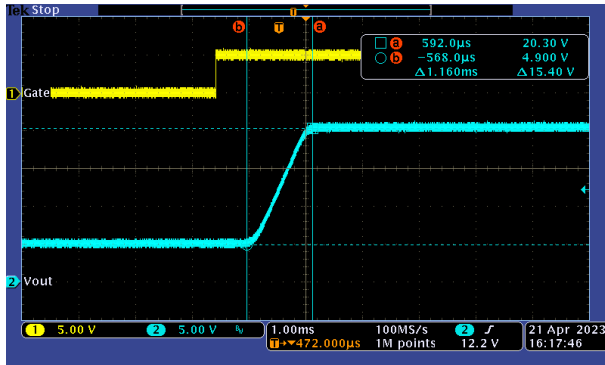

Figure 2-2. 24Vin-5Vout to 20Vout at 5A (Vout Slew Rate: 13.3V/ms)

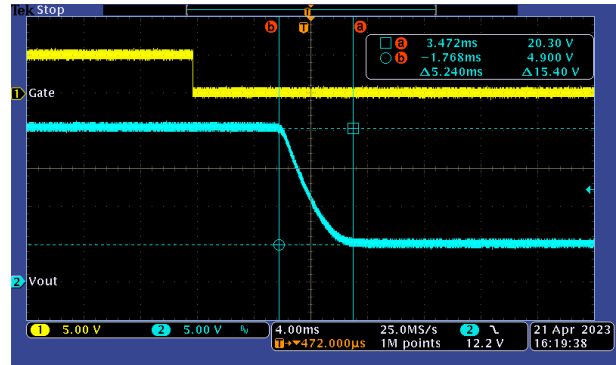

Figure 2-3. 24Vin-20Vout to 5Vout at 5A (Vout Slew Rate: 2.9V/ms)

### 2.2.2 Efficiency Curves

[Figure 2-4](#) shows efficiency curve under 24Vin. The highest efficiency can be up to 98.7% at 24Vin-20Vo-3A application condition.

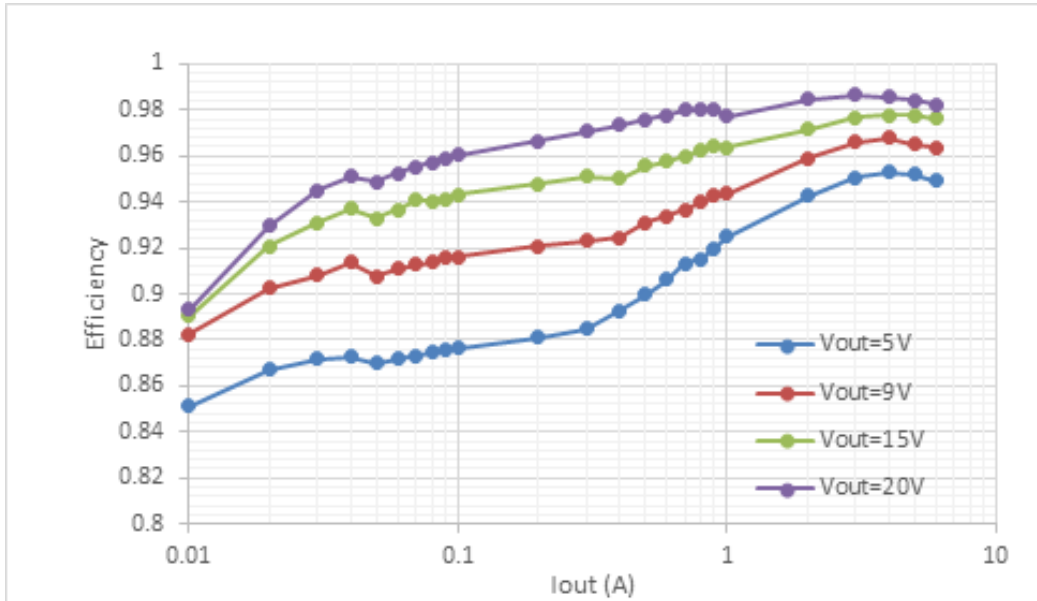

Figure 2-4. TPS56837HA Efficiency Curves

### 2.2.3 Thermal Pictures

[Figure 2-5](#) and [Figure 2-6](#) show 5Vout / 20Vout at 24V 5A conditions' thermal pictures.

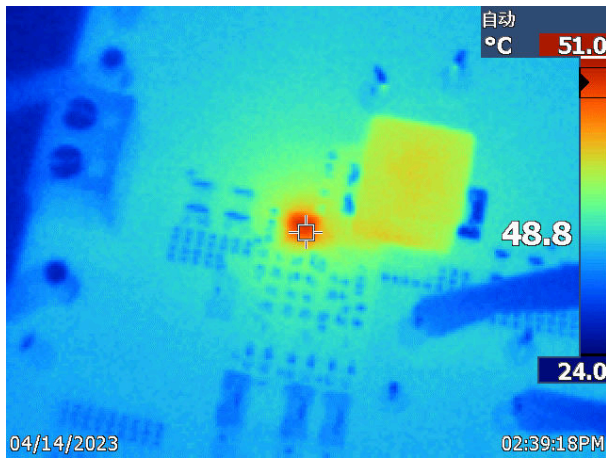

Figure 2-5. 24Vin-5Vout at 5A (Thermal: 51°C)

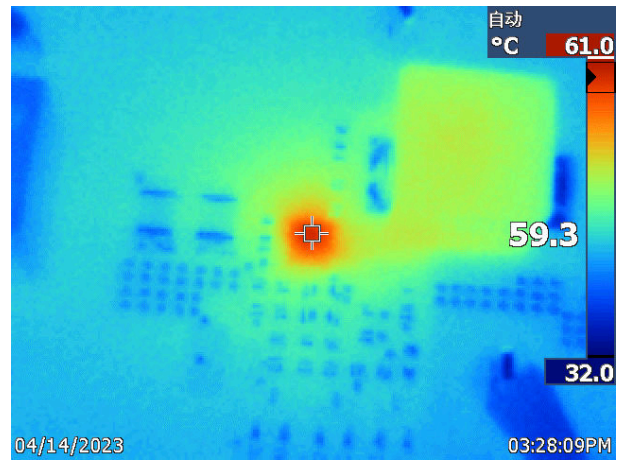

Figure 2-6. 24Vin-20Vout at 5A (Thermal: 61°C)

### 3 PD Controller Dedicated FB Pin to Control TPS56837HA Dynamic Output Change

Generally some PD controllers use FB current injection method to change DC/DC output voltage. Also some PD controllers integrate DCDC's Rfb so as to change DC/DC output voltage. The typical application is described in the following section.

#### 3.1 FB Current Injection PD Controller

Figure 3-1 shows PD controller injects current to FB-pin to configure TPS56837HA output voltage. The PD\_OUT and PD\_FB port are directly connected to PD controller pins. According to Kirchhoff's Current Law (KCL), the output voltage  $V_{out}$  can be derived from Equation 1, where  $V_{fb}$  is 0.6V.

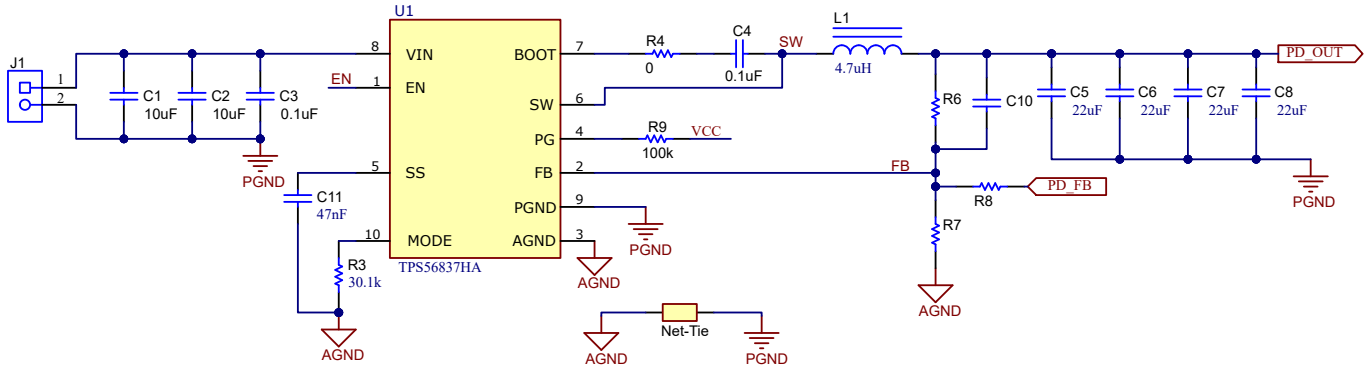

Figure 3-1. PD controller FB Current Injection for TPS56837HA Dynamically Output Change Reference Schematic

$$\frac{V_{out} - V_{fb}}{R_6} + \frac{V_{PF\_FB} - V_{fb}}{R_8} = \frac{V_{fb}}{R_7} \quad (1)$$

#### 3.2 Rfb Integrated PD Controller

Some PD controllers integrate DC/DC Rfb resistors. The reference circuit is shown in Figure 3-2.

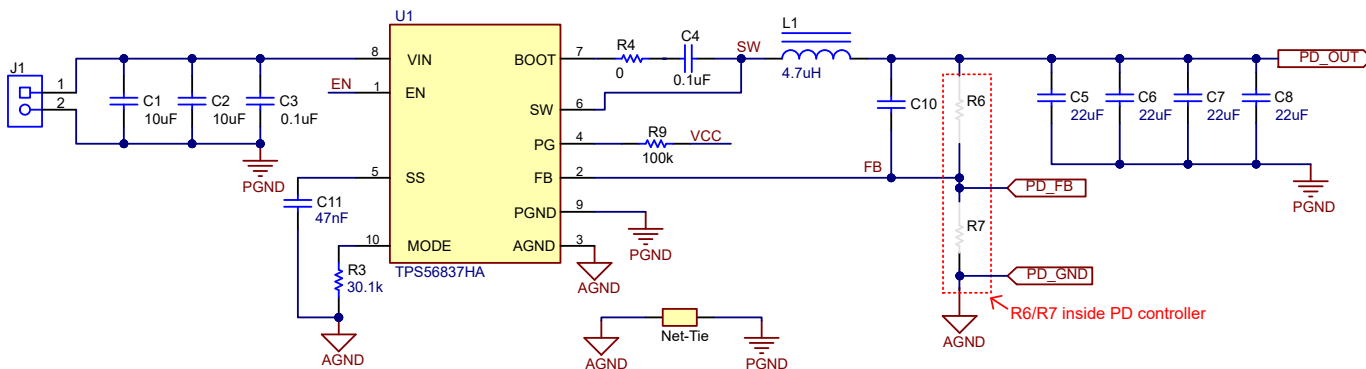

Figure 3-2. Integrated Rfb PD Controller for TPS56837HA Dynamically Output Change Reference Schematic

## 4 Summary

This application note covered TypeC PD standard brief introduction, TPS56837HA device description, GPIO control and FB-pin control methods of TPS56837HA output voltage dynamically change in TypeC PD application.

## 5 References

- Texas Instruments, [TPS56837Hx 4.5V to 28V Input, 8A, Synchronous Buck Converter](#), data sheet.
- Texas Instruments, [TI Live: USB Type-C PD3.1 Extended Power Range, and the Benefits of Type-C + BQ Solution](#).



## IMPORTANT NOTICE AND DISCLAIMER

TI PROVIDES TECHNICAL AND RELIABILITY DATA (INCLUDING DATA SHEETS), DESIGN RESOURCES (INCLUDING REFERENCE DESIGNS), APPLICATION OR OTHER DESIGN ADVICE, WEB TOOLS, SAFETY INFORMATION, AND OTHER RESOURCES "AS IS" AND WITH ALL FAULTS, AND DISCLAIMS ALL WARRANTIES, EXPRESS AND IMPLIED, INCLUDING WITHOUT LIMITATION ANY IMPLIED WARRANTIES OF MERCHANTABILITY, FITNESS FOR A PARTICULAR PURPOSE OR NON-INFRINGEMENT OF THIRD PARTY INTELLECTUAL PROPERTY RIGHTS.

These resources are intended for skilled developers designing with TI products. You are solely responsible for (1) selecting the appropriate TI products for your application, (2) designing, validating and testing your application, and (3) ensuring your application meets applicable standards, and any other safety, security, regulatory or other requirements.

These resources are subject to change without notice. TI grants you permission to use these resources only for development of an application that uses the TI products described in the resource. Other reproduction and display of these resources is prohibited. No license is granted to any other TI intellectual property right or to any third party intellectual property right. TI disclaims responsibility for, and you will fully indemnify TI and its representatives against, any claims, damages, costs, losses, and liabilities arising out of your use of these resources.

TI's products are provided subject to [TI's Terms of Sale](#) or other applicable terms available either on [ti.com](https://www.ti.com) or provided in conjunction with such TI products. TI's provision of these resources does not expand or otherwise alter TI's applicable warranties or warranty disclaimers for TI products.

TI objects to and rejects any additional or different terms you may have proposed.

Mailing Address: Texas Instruments, Post Office Box 655303, Dallas, Texas 75265  
Copyright © 2024, Texas Instruments Incorporated