

FABRICATION CHART			
FINISHED THICKNESS	SILKSCREEN	SOLDERMASK	FINISHED COPPER WEIGHT
<input type="checkbox"/> 0.031 <input checked="" type="checkbox"/> 0.062 <input type="checkbox"/> 0.093 <input type="checkbox"/> 0.125	<input checked="" type="checkbox"/> LAYER 1 <input checked="" type="checkbox"/> LAYER 2 <input type="checkbox"/> NONE	<input checked="" type="checkbox"/> LAYER 1 <input checked="" type="checkbox"/> LAYER 2 <input type="checkbox"/> NONE	<input type="checkbox"/> 1 OZ. <input checked="" type="checkbox"/> 2 OZ. <input type="checkbox"/> OTHER _____
DESIGN	TRACE/GAP SPACING	LAYER COUNT	
<input type="checkbox"/> SMD <input type="checkbox"/> THRU-HOLE <input checked="" type="checkbox"/> MIX	<input type="checkbox"/> 0.010/0.010 <input checked="" type="checkbox"/> 0.008/0.007 <input type="checkbox"/> 0.006/0.006	<input type="checkbox"/> SINGLE SIDED <input checked="" type="checkbox"/> 2 LAYER <input type="checkbox"/> 4 LAYER <input type="checkbox"/> OTHER _____	

NOTES: UNLESS OTHERWISE SPECIFIED

- MATERIAL:** ALL MATERIALS, INCLUDING BUT NOT LIMITED TO BASE LAMINATE, BONDING MATERIALS AND SOLDERMASK COATINGS FORMING THE FINISHED PRINTED CIRCUIT BOARD SHALL MEET UL-796 REQUIREMENTS AND BE RoHS COMPLIANT AND HAVE A FLAMMABILITY OF UL94V-0.
- BASE LAMINATE:** PLASTIC SHEET, LAMINATED METAL CLAD, TWO SIDES, BASE MATERIAL NEMA TYPE FR-4 GLASS EPOXY RESIN, COPPER-CLAD IN ACCORDANCE WITH 2 LAYER STACK-UP, COMPLIANT WITH LEAD FREE PROCESS.
- SOLDERMASK:** SOLDERMASK OVER BARE COPPER (SMOBC) USING LIQUID PHOTO-IMAGEABLE SOLDERMASK IN ACCORDANCE WITH IPC-SM-840.
- PLATING:** NO PLATING IN HOLES REQUIRED.
- FINISH:** PLATE WITH RoHS COMPLIANT, IMMERSION SILVER PREFERRED, IMMERSION TIN OR Sn/Ag/Cu, WITH RMA FLUX, 0.0005" +/- 0.0003" THICK MIN ALL EXPOSED AREAS AS COATED, NO ACTIVE FLUXES ARE ACCEPTABLE.
- LEGEND:** IF REQUIRED, SILKSCREEN LEGEND(S) WITH WHITE NON-CONDUCTIVE EPOXY INK.
- MARKINGS:** BOARD MUST BEAR VENDOR'S IDENTIFICATION CODE (ETCH OR WHITE NON-CONDUCTIVE INK). LOCATION OPTIONAL.
- WORKMANSHIP:** BOARD IS TO BE MANUFACTURED PER IPC-A-600 CLASS 2 REQUIREMENTS OR BETTER.
- DOCUMENTATION:** PCB VENDOR IS REQUIRED TO RETURN ANY AND ALL DOCUMENTS SUPPLIED OR ULTIMATELY PURCHASED BY TEXAS INSTRUMENTS UPON COMPLETION OF PURCHASE ORDER.
- DRILL SIZES:** HOLE DIAMETERS SHOWN ARE FINISHED SIZES AFTER PLATING UNLESS OTHERWISE NOTED.
- PANEL BORDER:** ANY METAL IN BORDER AREA INCLUDING PART NUMBER, DATECODE AND/OR REVISION LETTERS MUST BE COVERED WITH SOLDERMASK.
- PROCESS CHANGES:** NO DIMENSIONAL, MATERIAL, OR PROCESS CHANGES ARE ALLOWED WITHOUT PRIOR EXPLICIT WRITTEN PERMISSION FROM TEXAS INSTRUMENTS.

Hole Dia (inch)	Symbol	Quantity	Plated
0.010	+	38	Yes
0.035	X	4	No
0.038	Y	27	Yes
0.110	T	2	Yes

TEXAS INSTRUMENTS				Copper	Silkscreen	S Mask	Assembly	Fab Drawing	
Top	Bot	Top	Bot	Top	Bot	Top	Bot	Top	Bot
Board No. PR780	Rev. A	L1	L2	S1	S2	TA	BA	FB	
Date: 7-30-08	Filename: PR780A.pcb	Engineer: Uli Goerke	PCB Design: M Rodgers	Print Date: Thu Sep 18, 2008	Time Stamp: 11:12:41				

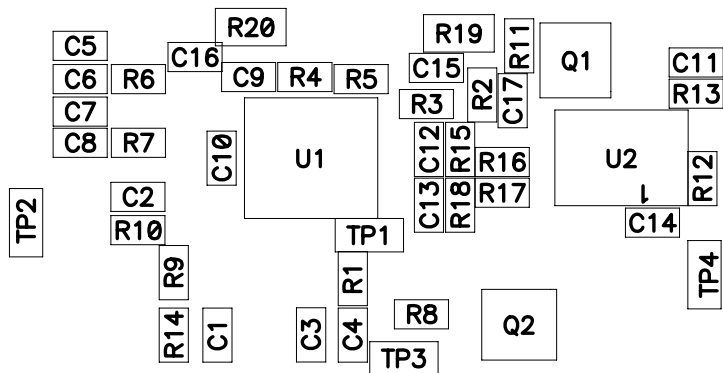

TEXAS INSTRUMENTS		Copper		Silkscreen		S Mask		Assembly		Fab Drawing
		Top	Bot	Top	Bot	Top	Bot	Top	Bot	
Board No. PR780		Rev. A						TA		
Date: 7-30-08	Filename: PR780A.pcb	Engineer: Uli Goerke		PCB Dsgnr: M Rodgers		Print Date: Thu Sep 18, 2008		Time Stamp: 11:12:40		

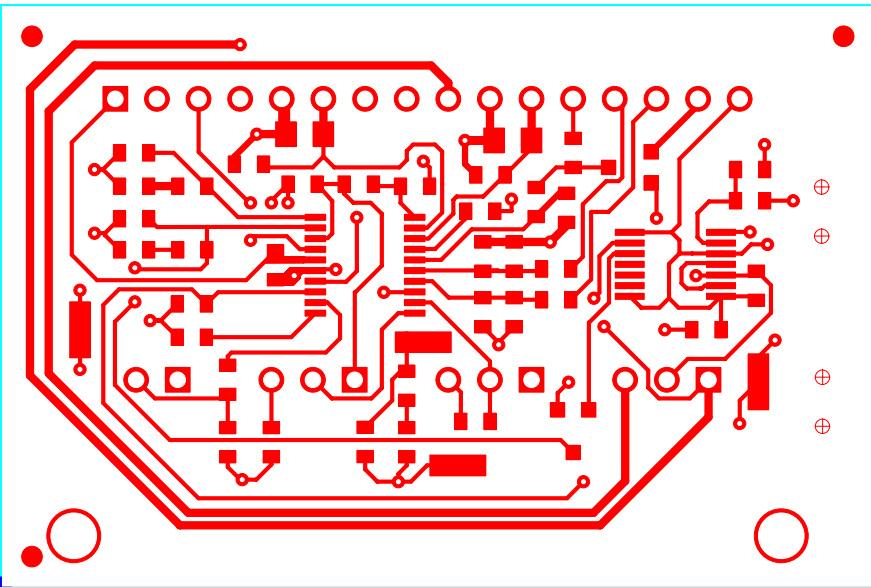

TEXAS INSTRUMENTS			Copper		Silkscreen		S Mask		Assembly		Fab Drawing
			Top	Bot	Top	Bot	Top	Bot	Top	Bot	
Board No. PR780	Rev. A	L1									
Date: 7-30-08	Filename: PR780A.pcb	Engineer: Uli Goerke	PCB Dsgnr: M Rodgers		Print Date: Thu Sep 18, 2008			Time Stamp: 11:12:40			

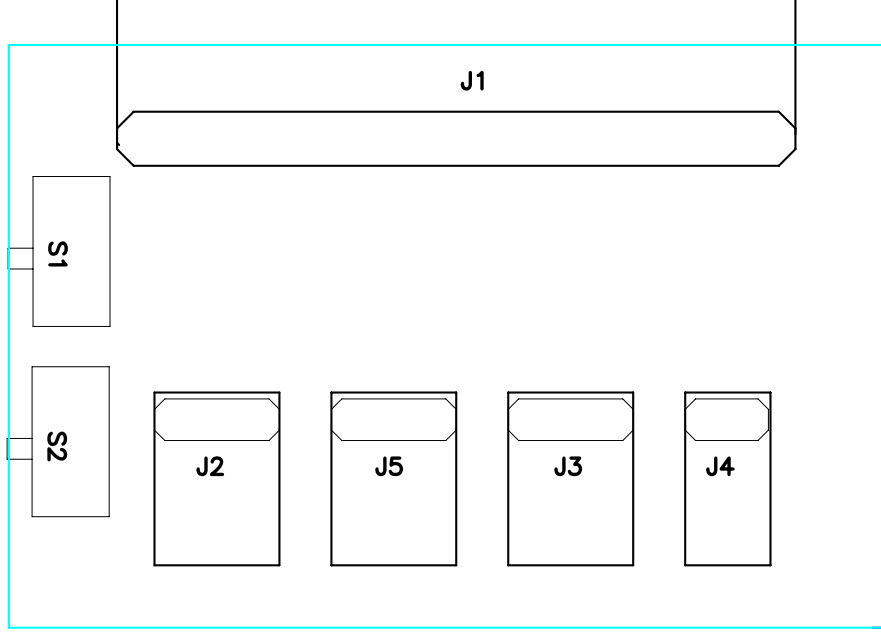

Date: 7-30-08		Filename: PR780A.pcb		Engineer: Uli Goerke		PCB Dsgnr: M Rodgers		Print Date: Thu Sep 18, 2008		Time Stamp: 11:12:40	
Board No. PR780		Rev. A								BA	
Texas Instruments		Top		Bot		Top		Bot		Top	
		Copper		Silkscreen		2 Mask		Assembly		Fab Drawing	

Date: 7-30-08	Filename: PR780A.pcb	Engineer: Uli Goerke	PCB Dsgnr: M Rodgers	Print Date: Thu Sep 18, 2008	Time Stamp: 11:12:40
Board No. PR780		Rev. A		22	
TEXAS INSTRUMENTS		Top	Bot	Top	Bot
		Top	Bot	Top	Bot
		Copper		2 Mask	
		Silkscreen		Assembly	
		Fab Drawing			

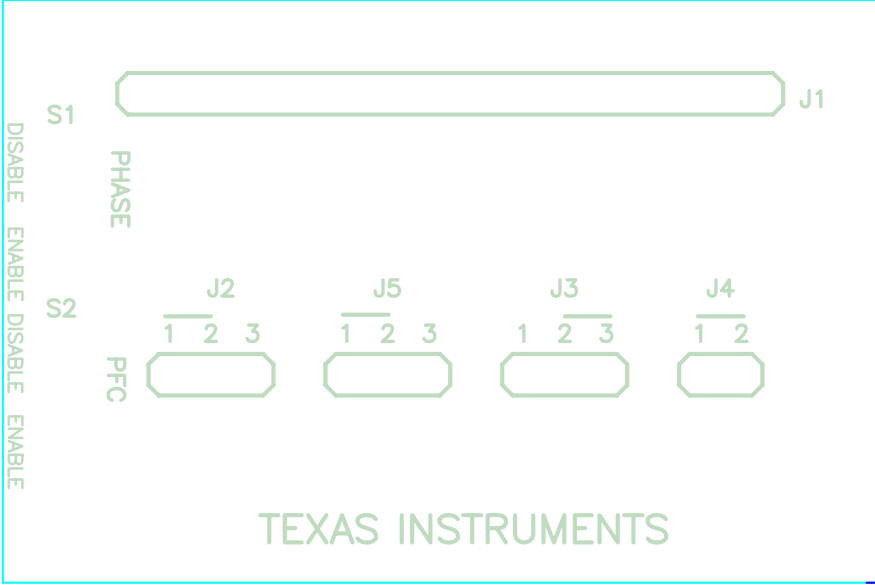

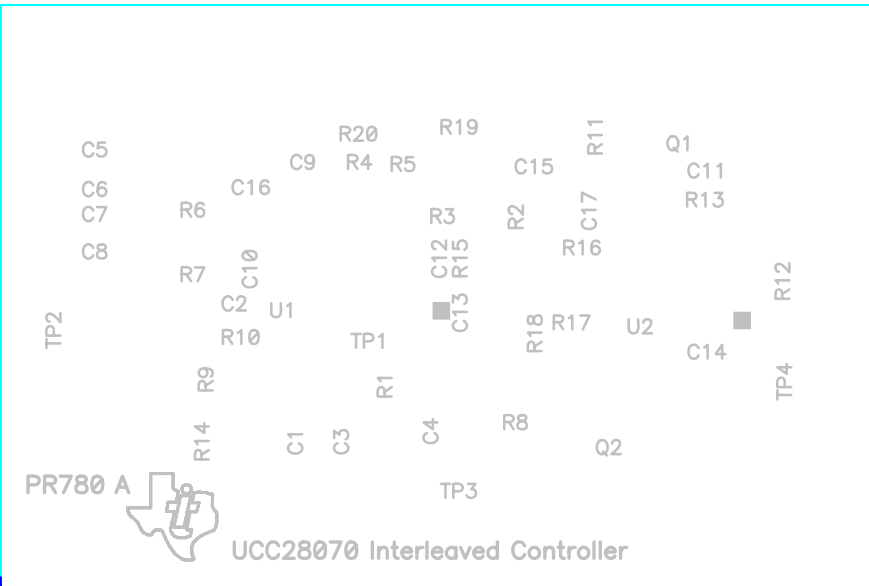

TEXAS INSTRUMENTS		Copper		Silkscreen		S Mask		Assembly		Fab Drawing
		Top	Bot	Top	Bot	Top	Bot	Top	Bot	
Board No. PR780	Rev. A			S1						
Date: 7-30-08	Filename: PR780A.pcb	Engineer: Uli Goerke		PCB Dsgnr: M Rodgers		Print Date: Thu Sep 18, 2008		Time Stamp: 11:12:41		

IMPORTANT NOTICE

Texas Instruments Incorporated and its subsidiaries (TI) reserve the right to make corrections, modifications, enhancements, improvements, and other changes to its products and services at any time and to discontinue any product or service without notice. Customers should obtain the latest relevant information before placing orders and should verify that such information is current and complete. All products are sold subject to TI's terms and conditions of sale supplied at the time of order acknowledgment.

TI warrants performance of its hardware products to the specifications applicable at the time of sale in accordance with TI's standard warranty. Testing and other quality control techniques are used to the extent TI deems necessary to support this warranty. Except where mandated by government requirements, testing of all parameters of each product is not necessarily performed.

TI assumes no liability for applications assistance or customer product design. Customers are responsible for their products and applications using TI components. To minimize the risks associated with customer products and applications, customers should provide adequate design and operating safeguards.

TI does not warrant or represent that any license, either express or implied, is granted under any TI patent right, copyright, mask work right, or other TI intellectual property right relating to any combination, machine, or process in which TI products or services are used. Information published by TI regarding third-party products or services does not constitute a license from TI to use such products or services or a warranty or endorsement thereof. Use of such information may require a license from a third party under the patents or other intellectual property of the third party, or a license from TI under the patents or other intellectual property of TI.

Reproduction of TI information in TI data books or data sheets is permissible only if reproduction is without alteration and is accompanied by all associated warranties, conditions, limitations, and notices. Reproduction of this information with alteration is an unfair and deceptive business practice. TI is not responsible or liable for such altered documentation. Information of third parties may be subject to additional restrictions.

Resale of TI products or services with statements different from or beyond the parameters stated by TI for that product or service voids all express and any implied warranties for the associated TI product or service and is an unfair and deceptive business practice. TI is not responsible or liable for any such statements.

TI products are not authorized for use in safety-critical applications (such as life support) where a failure of the TI product would reasonably be expected to cause severe personal injury or death, unless officers of the parties have executed an agreement specifically governing such use. Buyers represent that they have all necessary expertise in the safety and regulatory ramifications of their applications, and acknowledge and agree that they are solely responsible for all legal, regulatory and safety-related requirements concerning their products and any use of TI products in such safety-critical applications, notwithstanding any applications-related information or support that may be provided by TI. Further, Buyers must fully indemnify TI and its representatives against any damages arising out of the use of TI products in such safety-critical applications.

TI products are neither designed nor intended for use in military/aerospace applications or environments unless the TI products are specifically designated by TI as military-grade or "enhanced plastic." Only products designated by TI as military-grade meet military specifications. Buyers acknowledge and agree that any such use of TI products which TI has not designated as military-grade is solely at the Buyer's risk, and that they are solely responsible for compliance with all legal and regulatory requirements in connection with such use.

TI products are neither designed nor intended for use in automotive applications or environments unless the specific TI products are designated by TI as compliant with ISO/TS 16949 requirements. Buyers acknowledge and agree that, if they use any non-designated products in automotive applications, TI will not be responsible for any failure to meet such requirements.

Following are URLs where you can obtain information on other Texas Instruments products and application solutions:

Products

Amplifiers	amplifier.ti.com
Data Converters	dataconverter.ti.com
DLP® Products	www.dlp.com
DSP	dsp.ti.com
Clocks and Timers	www.ti.com/clocks
Interface	interface.ti.com
Logic	logic.ti.com
Power Mgmt	power.ti.com
Microcontrollers	microcontroller.ti.com
RFID	www.ti-rfid.com
RF/IF and ZigBee® Solutions	www.ti.com/lprf

Applications

Audio	www.ti.com/audio
Automotive	www.ti.com/automotive
Broadband	www.ti.com/broadband
Digital Control	www.ti.com/digitalcontrol
Medical	www.ti.com/medical
Military	www.ti.com/military
Optical Networking	www.ti.com/opticalnetwork
Security	www.ti.com/security
Telephony	www.ti.com/telephony
Video & Imaging	www.ti.com/video
Wireless	www.ti.com/wireless

Mailing Address: Texas Instruments, Post Office Box 655303, Dallas, Texas 75265
Copyright © 2009, Texas Instruments Incorporated