

TPS65982BBEVM Evaluation Module

User's Guide



Literature Number: SLVUBK7
August 2019

1	Trademarks	5
2	Introduction	5
2.1	Information About Cautions and Warnings	5
2.2	Related Documents	5
3	Setup	5
3.1	Items Required for Operation	5
3.2	USB Ports Functionality	6
3.3	Header Functionality	6
3.4	S1 Switch Bank Functionality	6
3.5	S2 TIVA Reset Switch	6
3.6	LED Indicators	6
4	Using the TPS65982BBEVM	7
4.1	Powering the TPS65982BBEVM	7
4.2	Port A and B to RP USB2 Mux and Billboard Function	7
4.3	RP USB 5V VBUS	7
4.4	Port A/B USB Type-C Ports	7
4.5	TPS65982BB GPIO Summary	7
4.6	TPS65982BB I2C Control	8
4.7	I2C Control Example - Enable Billboard on Port A	9
4.8	Debugging the EVM	9
5	Board Layout	9
6	Schematic and Bill of Materials	13
6.1	Schematic	13
6.2	Bill of Materials	15

List of Figures

1	Board Stack-Up	9
2	Top Layer.....	10
3	High-Speed Layer	10
4	Power 1 Layer	11
5	Power 2 Layer	11
6	Bottom Layer.....	12
7	TPS65982BB Schematic	13
8	USB Connectors.....	14
9	TIVA.....	14
10	Power Supplies	15

List of Tables

1	USB Ports Functionality.....	6
2	Header Functionality	6
3	S1 Switch Back Functionality	6
4	LED Indicators.....	6
5	TPS65982BB GPIO Summary	7
6	TPS65982BB Configuration - Data1 Register I2C Write	8
7	Bill of Materials	15

TPS65982BBEVM Evaluation Module

This document is the user's guide for the TPS65982BB Evaluation Module (TPS65982BBEVM). The TPS65982BBEVM allows for the evaluation of the TPS65982BB IC, which is used in Type-C and PD applications that require USB Billboard functionality. The TPS65982BBEVM demonstrates the integrated USB mux, allowing billboard functionality for two USB Type-C ports. It also includes a Downstream Face Port (DFP) USB Type-A receptacle to pass through USB2 signals and VBUS to a device when billboard functionality is not required. The TPS65982BBEVM is supported with the *TPS65982BB Application Configuration* software tool to enable the billboard feature over I2C communication.

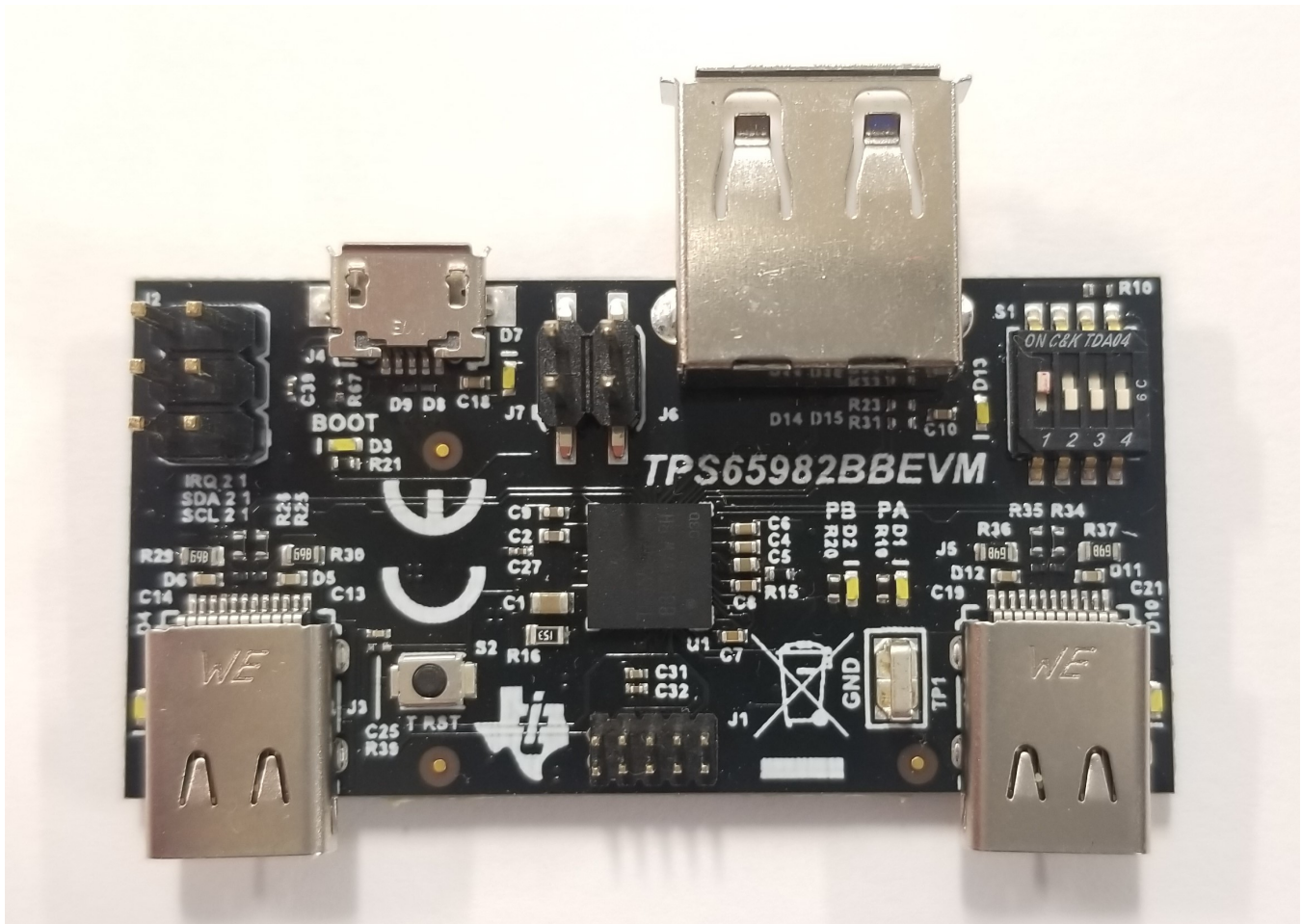

1 Trademarks

All trademarks are the property of their respective owners.

2 Introduction

The TPS65982BBEVM helps designers evaluate the functions for the TPS65982BB billboard device. The TPS65982BB can work in single-port and dual-port applications where billboard is required. The two Type-C ports represent a dual-port application where the USB signals can be passed through to the DFP USB Type-A port or provide the billboard function to the USB Type-C port connected to a USB host. The DFP USB Type-A port provides 5 V through the TPS65982BB integrated power switch. The onboard I2C communication tool aids in developing the I2C control from an Embedded Controller or Power Delivery Controller in the system. The TPS65982BBEVM can be powered either from the USB Type-C port or the USB micro B port that interfaces with the *TPS65982BB Application Configuration* software tool. The onboard I2C communication is controlled by the TIVA microcontroller, which also has the ability to update the TPS65982BB configurations.

2.1 Information About Cautions and Warnings

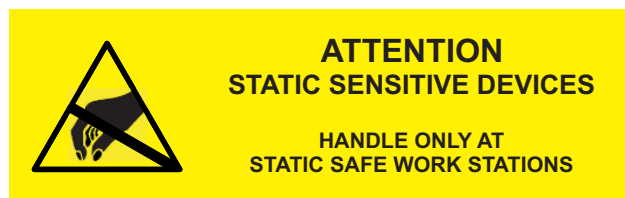

CAUTION

This EVM contains components that can potentially be damaged by electrostatic discharge. Always transport and store the EVM in the supplied ESD bag when not in use. Handle while using an antistatic wristband. Operate on an antistatic work surface. For more information on proper handling, see [Electrostatic Discharge \(ESD\)](#).

2.2 Related Documents

- [Universal Serial Bus Specification, Revision 2.0, April 27, 2000 plus ECN and Errata.](#)
- [Billboard Device Class Spec Revision 1.21, September 08, 2016.](#)
- [USB Power Delivery Specification Revision 3.0, Version 1.0a](#)
- [USB Type-C Cable and Connector Specification Revision 1.2, March 25, 2016.](#)
- [Proposed DisplayPort Alt Mode on USB Type-C Standard, Version 1, Draft 5, September 6, 2014](#)

3 Setup

3.1 Items Required for Operation

The following items are required for full evaluation of the EVM:

- [TPS65982BB Data Sheet](#)
- [TPS65982BB Host Interface Technical Reference Manual](#)
- TPS65982BBEVM

- TPS65982BB Application Customization Tool
- USB Type-A to USB Micro-B Cable (Interface with I2C Master)
- USB Type-C to Type-C cable or USB Type-A to USB Type-C
- USB Device (flash drive, mouse, and so forth)

3.2 USB Ports Functionality

Table 1. USB Ports Functionality

DESIGNATOR	DESCRIPTION
J5	Port A USB Type-C Upstream Facing Port
J3	Port B USB Type-C Upstream Facing Port
J4	USB micro B port used to interface with the <i>TPS65982BB Application Configuration</i> software tool
J6	RP USB Type-A Downstream Facing Port, USB2 signals muxed from either Port A/B USB Type-C Ports

3.3 Header Functionality

Table 2. Header Functionality

DESIGNATOR	DESCRIPTION
J1	TPS65982BB SPI pins and GPIO control signals, used to probe and measure signals
J2	TPS65982BB I2C1/2 pins, used to probe I2C communication or control the TPS65982BB through an external I2C master
J7	TIVA I2C master JTAG pins, used only for internal debugging

3.4 S1 Switch Bank Functionality

Table 3. S1 Switch Back Functionality

SWITCH (S1)	DESCRIPTION
1	PP_5V0_EN Control: Enables/disables the 5 V supply to the RP USB Type-A Port.
2	BB_ENABLE: Automatically enables billboard functions on the Port A USB Type-C, used when I2C control is not available
3	SPI_MISO: TPS65982BB SPI_MISO pin, used for debugging purposes only
4	BB_RST: TPS65982BB hardware reset control

3.5 S2 TIVA Reset Switch

S2 is used to reset the TIVA I2C master to recover from a communication error to the TPS65982BB or to the *TPS65982BB Application Configuration* software tool. This switch is not intended to be used outside of error recovery for the TIVA microcontroller.

3.6 LED Indicators

Table 4. LED Indicators

DESIGNATOR	DESCRIPTION
D1	BB_PLUG_PA LED Indicator
D2	BB_PLUG_PB LED Indicator

Table 4. LED Indicators (continued)

DESIGNATOR	DESCRIPTION
D3	BB_BOOT_OK LED Indicator
D4	Port B USB Type-C VBUS LED Indicator
D10	Port A USB Type-C VBUS LED Indicator
D7	TIVA USB micro B VBUS LED Indicator
D13	RP USB Type-A VBUS LED Indicator

4 Using the TPS65982BBEVM

4.1 Powering the TPS65982BBEVM

The board is powered from either Port A/B USB Type-C or the USB micro B connectors. The VBUS are all connected to the system rail, which provides 5 V to the RP USB Type-A connector through the TPS65982BB. Each path is RCP-protected and the highest VBUS voltage is passed through to the system.

4.2 Port A and B to RP USB2 Mux and Billboard Function

When a connection is made on one of the Type-C ports, the USB signals are connected to the RP USB path. The BB_PLUG_PA/B controls are first come first serve, which means the first port to get connected maintains the USB path. A USB device can be connected to the USB Type-A receptacle and must enumerate to the connected USB host. The USB path is disabled when the billboard function is enabled through I2C or through the BB_ENABLE control signal. When BB_ENABLE is used, it forces the billboard function on the Port A USB Type-C only. With I2C control, the billboard functions can be connected to either Port A/B.

4.3 RP USB 5V VBUS

The 5 V for the RP USB Type-A port can be controlled from the S1 switch bank. In order to supply power to a USB device connected to the Type-A receptacle, this control signal must be enabled.

4.4 Port A/B USB Type-C Ports

These ports are both UFP ports and always present Rd pulldowns on the CC lines. The EVM is only intended to operate with 5 V on VBUS. **Verify the connected USB Type-C DFP is not applying greater than 5 V, as this will permanently damage the EVM.**

4.5 TPS65982BB GPIO Summary

The TPS65982BBEVM exposes all of the GPIO required to operate the TPS65982BB. The BB_PLUG_PA/B GPIO are generated by logic at each Type-C connector. PP_5V0_EN is controlled through the S1 switch bank.

Table 5. TPS65982BB GPIO Summary

TPS65982BB GPIO		
GPIO EVENT	INPUT/OUTPUT	COMMENT
BB_ENABLE	Input	Enables the billboard function with iAdditionalInfoURL on PA_USB_P/N only.
PP_5V0_EN	Input	PP_5V0_EN = 0: Disables the 5 V. VBUS Switch PP_5V0_EN = 1: Enables the 5 V VBUS Switch

Table 5. TPS65982BB GPIO Summary (continued)

TPS65982BB GPIO		
GPIO EVENT	INPUT/OUTPUT	COMMENT
BB_PLUG_PA	Input	BB_PLUG_PA = 0: Disconnect PA_USB_P/N (Port A Type-C USB) to USB_RP_P/N. BB_PLUG_PA = 1: Connect PA_USB_P/N (Port A Type-C USB) to USB_RP_P/N.
BB_PLUG_PB	Input	BB_PLUG_PB = 0: Disconnect PB_USB_P/N (Port A Type-C USB) to USB_RP_P/N. BB_PLUG_PB = 1: Connect PB_USB_P/N (Port A Type-C USB) to USB_RP_P/N.
HRESET	Input	BB_RESET = 0: Normal Operation BB_RESET = 1: Hardware Reset (Firmware Reload)
BB_SRST	Input	BB_SRESET = 1: Soft Reset (No Firmware Reload) BB_SRESET = 0: Normal Operation
BB_BOOT_OK	Output	BB_Boot = 0: Not Booted BB_Boot = 1: Successful Boot

4.6 TPS65982BB I2C Control

The TPS65982BBEVM uses a TIVA microcontroller to execute the I2C writes required to control the TPS65982BB. The configuration of the TPS65982BB is set by writing to the Data1 register and then executing a 4CC command by writing BDCc to the CMD1 register. For additional details, refer to the TPS65982BB Host Interface.

Table 6 shows the configuration options programmable through I2C.

Table 6. TPS65982BB Configuration - Data1 Register I2C Write

INPUT TO DATA REGISTER		
BIT	DEFINITION	COMMENT
0	Enable Billboard = 1 Disable Billboard = 0	Overrides USB_RP connection when enabled
1	PA_USB_P/N Connected = 1 PB_USB_P/N Connected = 0	PA_USB_P/N Connection PB_USB_P/N Connection
2	Enable RP = 1 Disable RP = 0	Connects USB2 to USB RP
3	Enable iAdditionalinfoURL2 = 1 Disable iAdditionalinfoURL2 = 0	Uses iAdditionalinfoURL2
4:5	00: TBT Mode Entry Error 01: DP Mode Entry Error 10: CIO Mode Entry Error 11: No Mode Entry Error	Shows descriptor pertaining to which alternate mode failed
6:7	00: TBT Mode Entry Successful 01: DP Mode Entry Successful 10: CIO Mode Entry Successful 11: No Mode Entry Successful	Shows descriptor pertaining to which alternate mode entered. Use when no USB Hub or USB System present.
8	0: Mode Entry Error (Capabilities Mismatch) 1: Mode Entry Failure due to no PD comm	Sets the reason why the preferred Alt Mode was not entered.
9:11	000: TBT String 001: DP String 010: CIO String 011: Reserved (Future Use) 100-111: Use Default Billboard String	Option to force a specific Billboard String when request is received
12:15	Reserved	Write all zeros.

4.7 I2C Control Example - Enable Billboard on Port A

1. I2C Master Write to device TPS65982BB address (0x38)
 - a. Data1 Register address (0x09)
 - b. 2 Byte Write
 - c. 0x3EF0
2. I2C Master Write to device TPS65982BB address (0x38)
 - a. CMD1 Register address (0x08)
 - b. 4 Byte Write
 - c. 0x42444363 (BDCc)

4.8 Debugging the EVM

Use the following when the EVM is not working as expected.

- Every USB input has a VBUS LED indicator. Verify that the host connected is providing 5 V on VBUS.
- D3 (BOOT) LED indicates that the TPS65982BB has loaded its firmware successfully. When this LED is off and VBUS LED is present, the firmware for the TPS65982BB may have to be programmed to the SPI flash. Refer to the TPS65982BB Application Customization Tool for the recovery firmware.

5 Board Layout

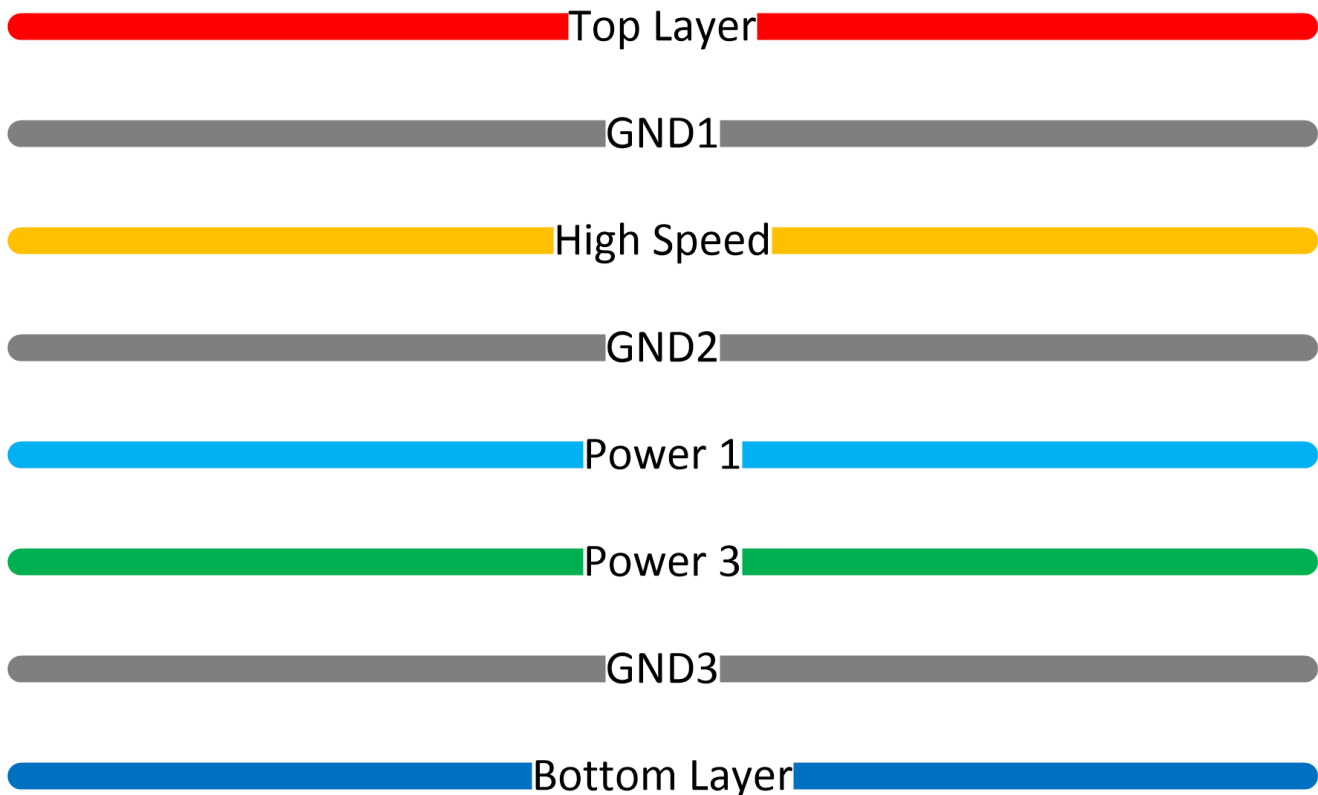

Figure 1. Board Stack-Up

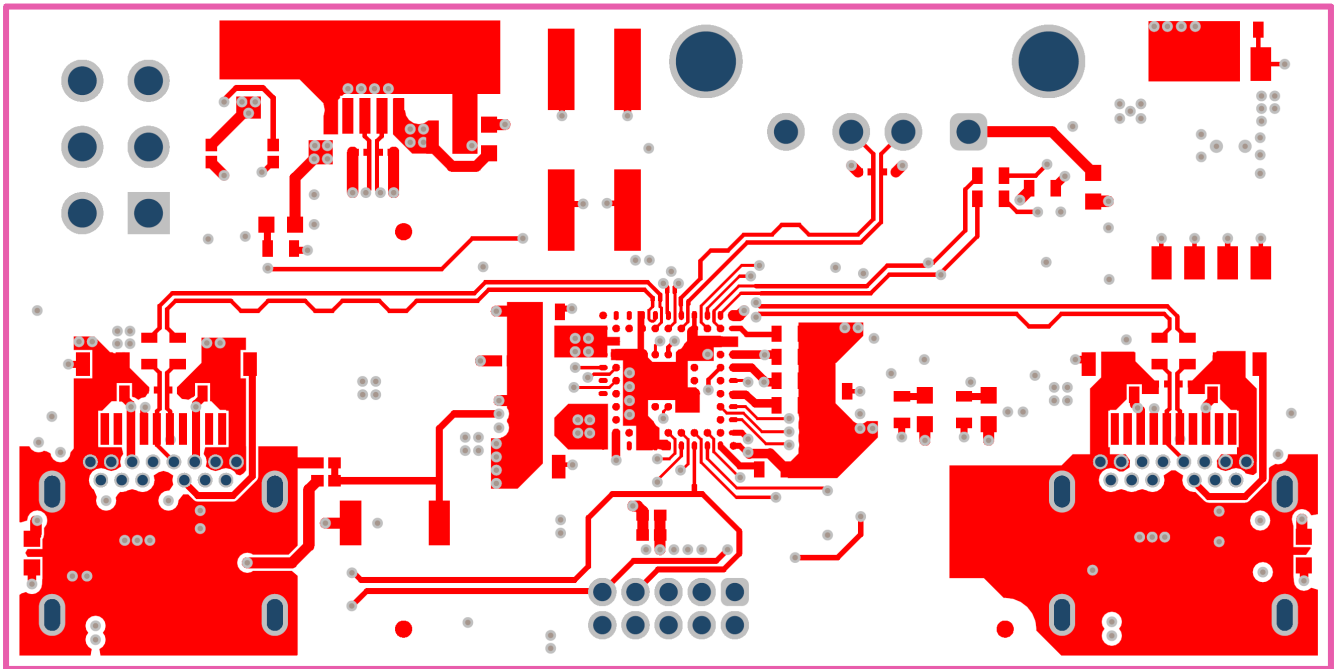

Figure 2. Top Layer

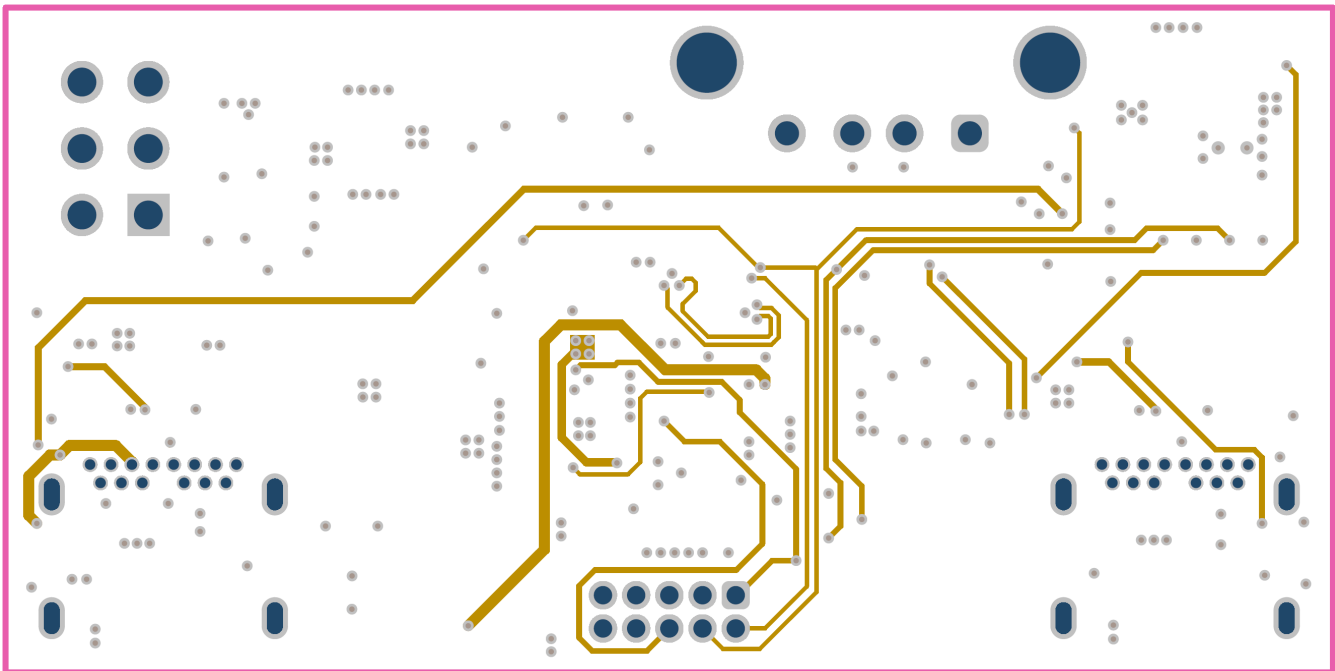

Figure 3. High-Speed Layer

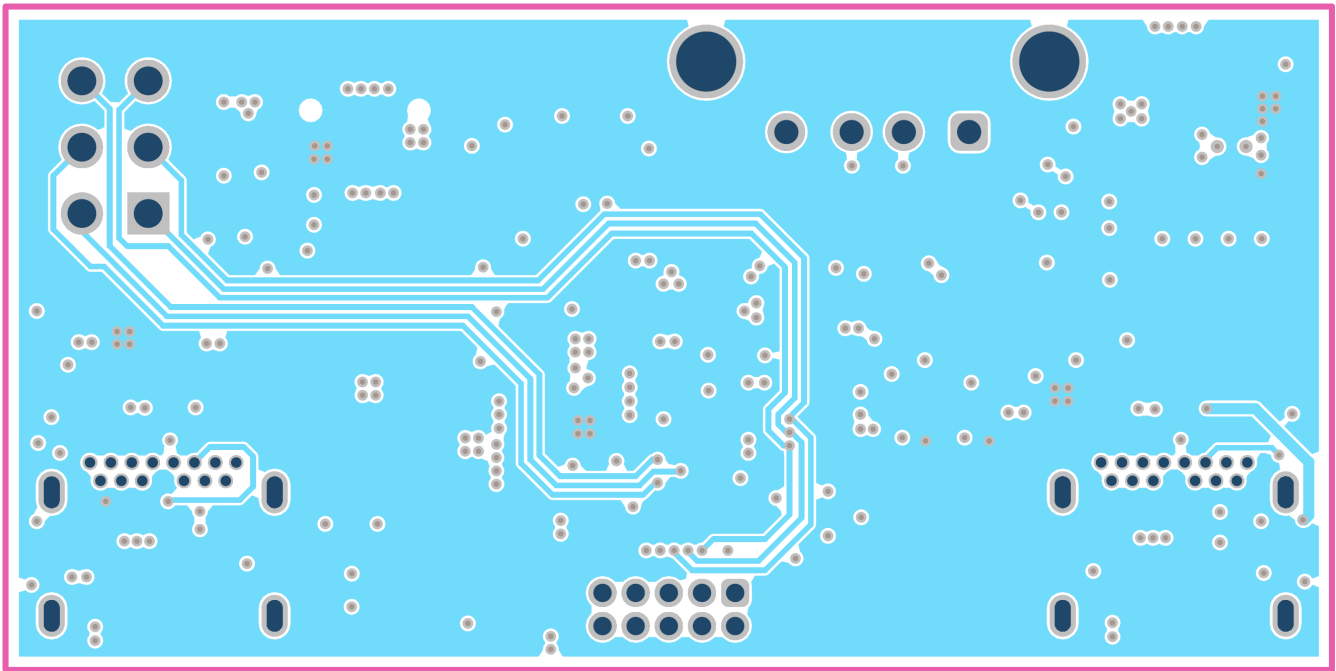

Figure 4. Power 1 Layer

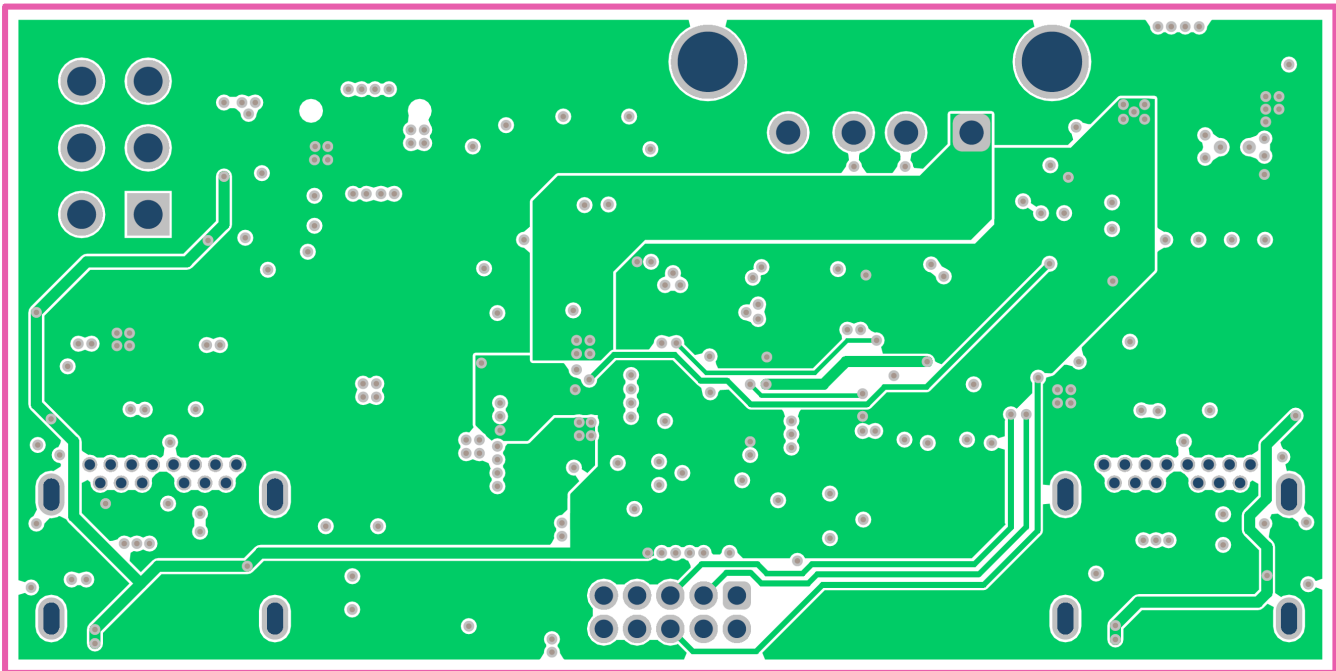

Figure 5. Power 2 Layer

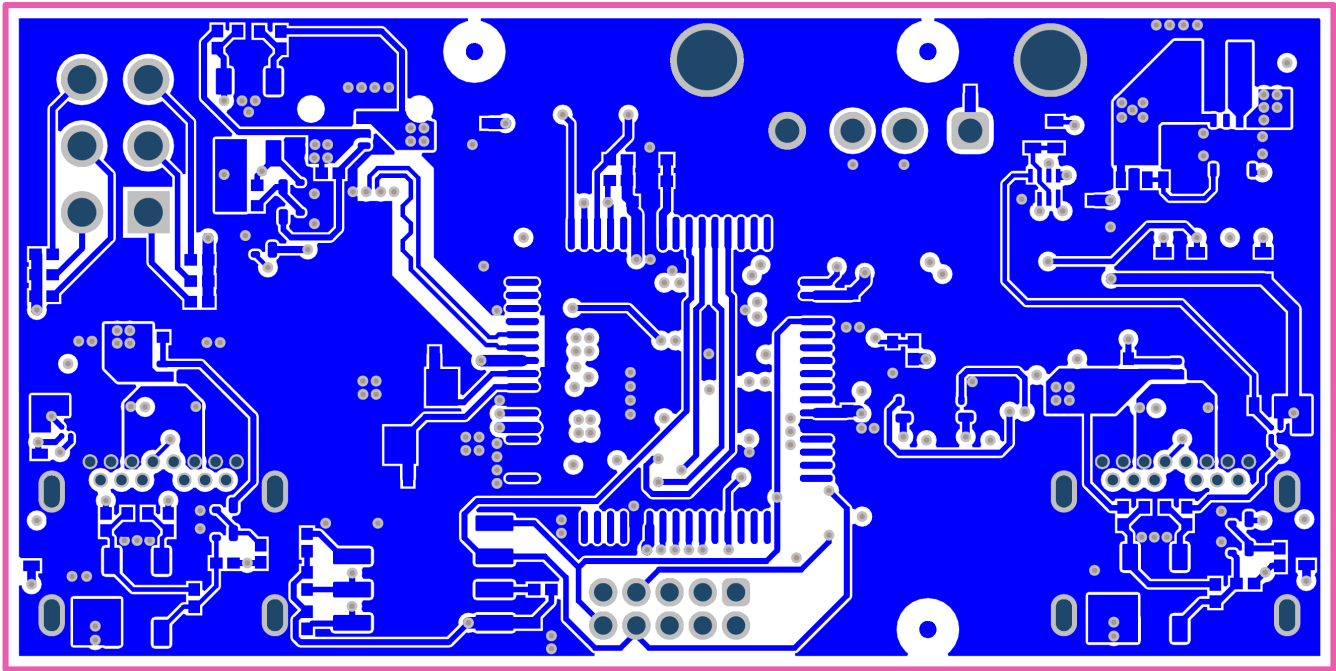
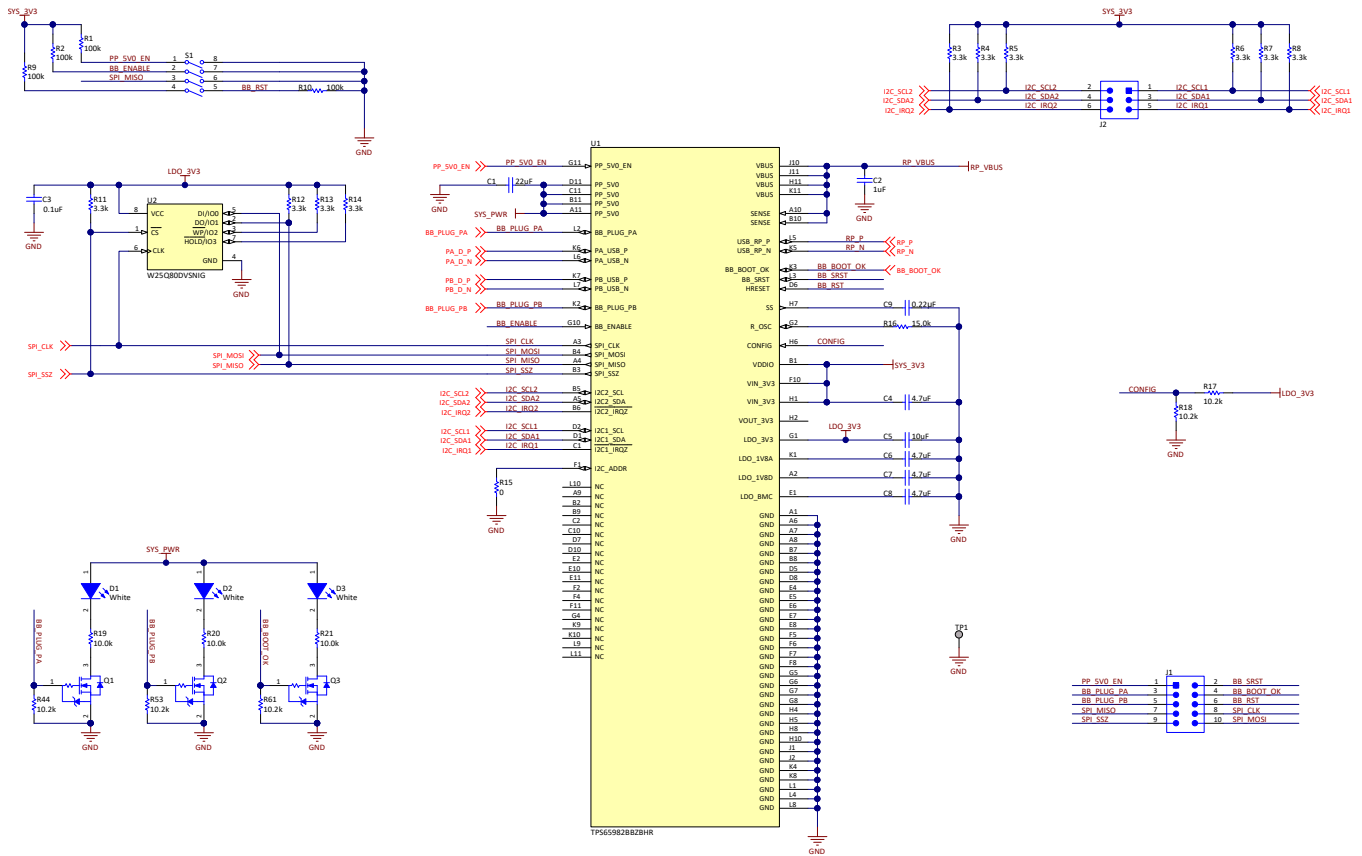

Figure 6. Bottom Layer

6 Schematic and Bill of Materials

6.1 Schematic



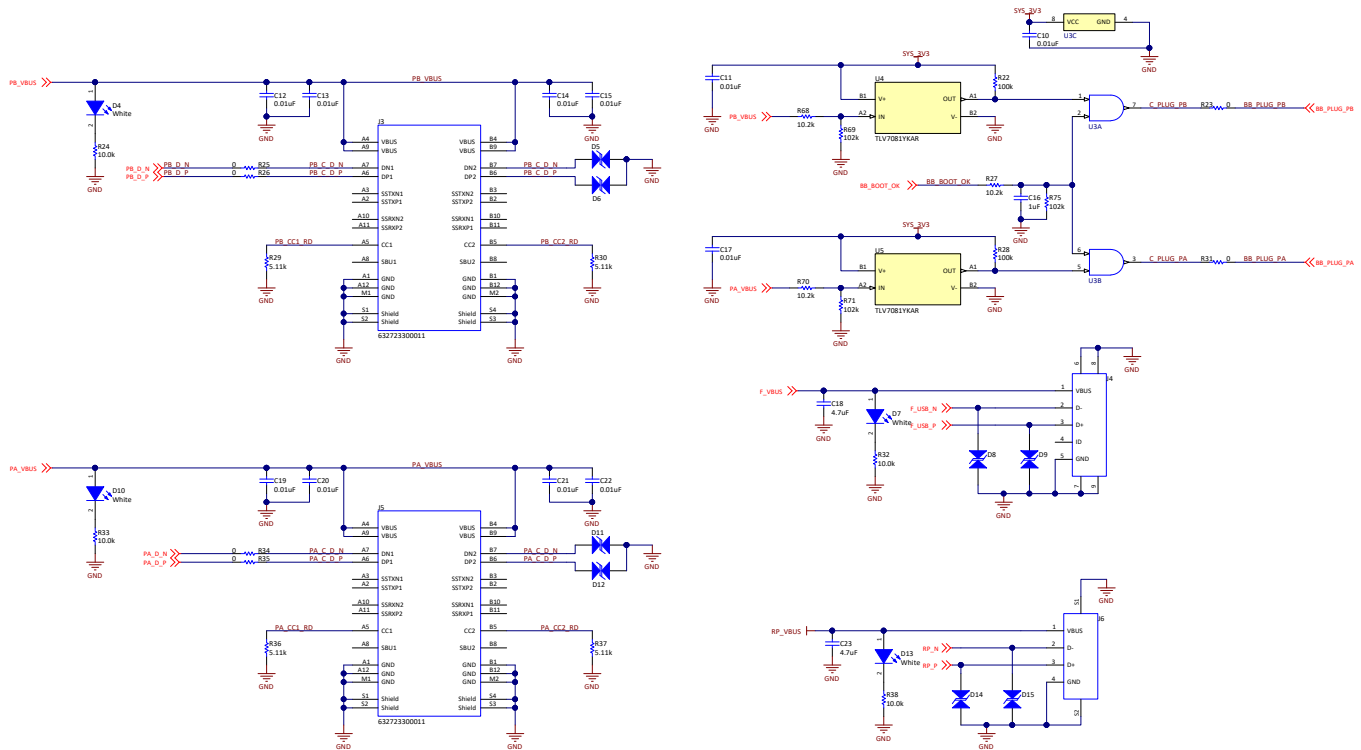

Figure 8. USB Connectors

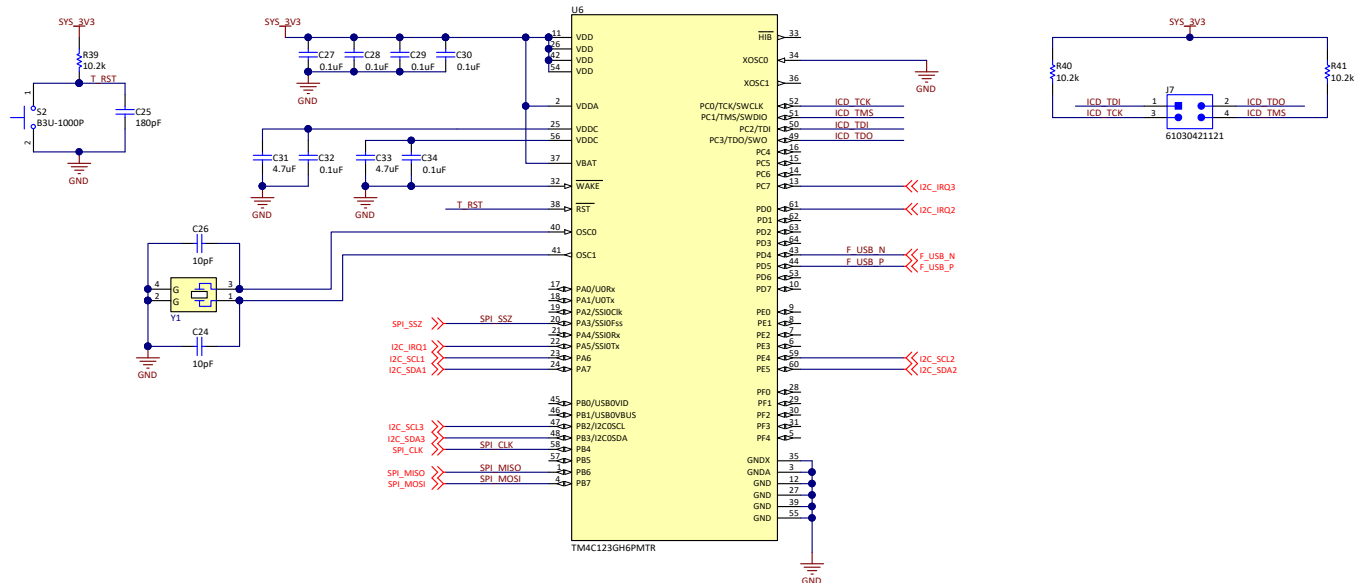

Figure 9. TIVA

Table 7. Bill of Materials (continued)

DESIGNATOR	QUANTITY	VALUE	DESCRIPTION	PACKAGE REFERENCE	PART NUMBER	MANUFACTURER
C5, C35	2	10 μ F	CAP, CERM, 10 μ F, 10 V, +/- 20%, X5R, 0402	0402	CL05A106MP5NU NC	Samsung Electro-Mechanics
C9	1	0.22 μ F	CAP, CERM, 0.22 μ F, 10 V, +/- 20%, X5R, 0402	0402	885012105011	Würth Elektronik
C10, C11, C12, C13, C14, C15, C17, C19, C20, C21, C22	11	0.01 μ F	CAP, CERM, 0.01 μ F, 16 V, +/- 10%, X7R, 0402	0402S	885012205031	Würth Elektronik
C24, C26	2	10 pF	CAP, CERM, 10 pF, 16 V, +/- 10%, C0G, 0402	0402	C0402C100K4GAC TU	Kemet
C25	1	180 pF	CAP, CERM, 180 pF, 25 V, +/- 10%, X7R, 0201	0201	GRM033R71E181 KA01D	MuRata
C31, C33	2	4.7 μ F	CAP, CERM, 4.7 μ F, 6.3 V, +/- 20%, X5R, 0201	0201	GRM035R60J475 ME15D	MuRata
C36	1	22 μ F	CAP, CERM, 22 μ F, 10 V, +/- 20%, X5R, 0805	0805	885012107011	Würth Elektronik
C40, C41, C42	3	0.1 μ F	CAP, CERM, 0.1 μ F, 16 V, +/- 10%, X5R, 0201	0201	GRM033R61C104 KE14D	MuRata
D1, D2, D3, D4, D7, D10, D13	7	White	LED, White, SMD	0402, White	LW QH8G-Q2S2-3K5L-1	OSRAM
D5, D6, D8, D9, D11, D12, D14, D15	8		1-Channel ESD Protection Diode for USB Type-C and Antenna Protection, DPL0002A (X2SON-2)	DPL0002A	TPD1E0B04DPLR	Texas Instruments
J2	1		Header, 2.54 mm, 3x2, Gold, TH	Header, 2.54 mm, 3x2, TH	61300621121	Würth Elektronik
J3, J5	2		Connector, Receptacle, USB Type-C, R/A	Connector, Receptacle, USB Type-C, R/A, THT/SMT	632723300011	Würth Elektronik
J4	1		USB 2.0 TYPE B, R/A, SMT	USB 2.0 TYPE B, R/A, SMT	629105136821	Würth Elektronik
J6	1		USB 2.0 Type A, 4 Pos, Gold, R/A, TH	USB Type A R/A	61400416021	Würth Elektronik
J7	1		Header, 2.54 mm, 2x2, Gold, SMT	Header, 2.54 mm, 2x2, Gold, TH	61030421121	Würth Elektronik
L1	1	1 μ H	Inductor, Shielded, Powdered Iron, 1 μ H, 2.8 A, 0.06 Ω , SMD	SMD, 2.5x2 mm	74438324010	Würth Elektronik
Q1, Q2, Q3, Q5, Q6, Q8, Q9, Q11, Q12	9	30 V	MOSFET, N-CH, 30 V, 3 A, YJJ0003A (PICOSTAR-3)	YJJ0003A	CSD17484F4T	Texas Instruments
Q4, Q7, Q10	3	-20 V	MOSFET, P-CH, -20 V, -5.3 A, YJK0003A (PICOSTAR-3)	YJK0003A	CSD25485F5	Texas Instruments
R1, R2, R9, R10, R22, R28	6	100 k	RES, 100 k, 5%, 0.063 W, AEC-Q200 Grade 0, 0402	0402	CRCW0402100KJ NED	Vishay-Dale
R3, R4, R5, R6, R7, R8, R11, R12, R13, R14	10	3.3 k	RES, 3.3 k, 5%, 0.05 W, 0201	0201	RC0201JR-7D3K3L	Yageo America

Table 7. Bill of Materials (continued)

DESIGNATOR	QUANTITY	VALUE	DESCRIPTION	PACKAGE REFERENCE	PART NUMBER	MANUFACTURER
R15, R23, R31	3	0	RES, 0, 5%, 0.063 W, 0402	0402	RC0402JR-070RL	Yageo America
R16	1	15.0 k	RES, 15.0 k, 0.1%, 0.1 W, 0603	0603	RG1608P-153-B-T5	Susumu Co Ltd
R19, R20, R21	3	10.0 k	RES, 10.0 k, 1%, 0.063 W, 0402	0402	RC0402FR-0710KL	Yageo America
R24, R32, R33, R38	4	10.0 k	RES, 10.0 k, 1%, 0.063 W, AEC-Q200 Grade 0, 0402	0402	CRCW040210K0F KED	Vishay-Dale
R25, R26, R34, R35	4	0	RES, 0, 5%, 0.063 W, 0402	0402S	RC0402JR-070RL	Yageo America
R27, R39, R40, R41, R42, R44, R47, R49, R50, R52, R53, R56, R57, R58, R60, R61, R64, R65, R66, R68, R70	21	10.2 k	RES, 10.2 k, 1%, 0.05 W, 0201	0201	RC0201FR-0710K2L	Yageo America
R29, R30, R36, R37	4	5.11 k	RES, 5.11 k, 1%, 0.1 W, AEC-Q200 Grade 0, 0603	0603S	CRCW06035K11F KEA	Vishay-Dale
R43	1	249 k	RES, 249 k, 1%, 0.063 W, AEC-Q200 Grade 0, 0402	0402	CRCW0402249KF KED	Vishay-Dale
R45, R46, R54, R55, R62, R63	6	60.4 k	RES, 60.4 k, 1%, 0.05 W, 0201	0201	RC0201FR-7D60K4L	Yageo America
R48	1	39.2 k	RES, 39.2 k, 1%, 0.063 W, AEC-Q200 Grade 0, 0402	0402	CRCW040239K2F KED	Vishay-Dale
R51, R59, R67, R69, R71, R75	6	102 k	RES, 102 k, 1%, 0.05 W, 0201	0201	ERJ-1GEF1023C	Panasonic
R72, R73, R74	3	510 k	RES, 510 k, 5%, 0.05 W, 0201	0201	RC0201JR-07510KL	Yageo America
S1	1		DIP Switch, SPST 4Pos, Slide, SMT	6.2x2.0x6.2 mm	TDA04H0SB1	C&K Components
S2	1		SWITCH TACTILE SPST-NO 0.05 A 12 V	3x1.6x2.5 mm	B3U-1000P	Omron Electronic Components
TP1	1		Test Point, Miniature, SMT	Test Point, Miniature, SMT	5019	Keystone
U1	1		Dual USB Billboard for USB-PD Devices with Integrated 5 V Load Switch, ZBH0096A (NFBGA-96)	ZBH0096A	TPS65982BBZBHR	Texas Instruments
U2	1		3 V, 8Mbit, Serial Flash Memory with Dual and Qual SPI, SOIC-8	SOIC-8	W25Q80DVSNIG	Winbond
U3	1		Low-Power Dual 2-Input Positive-AND Gate, DQE0008A, LARGE T&R	DQE0008A		Texas Instruments
U4, U5	2		NanoPower, MicroPackage Low-Voltage Comparator, YKA0004ACAC (DSBGA-4)	YKA0004ACAC	TLV7081YKAR	Texas Instruments

Table 7. Bill of Materials (continued)

DESIGNATOR	QUANTITY	VALUE	DESCRIPTION	PACKAGE REFERENCE	PART NUMBER	MANUFACTURER
U6	1		Tiva C Series Microcontroller, 256 KB Flash, 32 KB SRAM, 12 Bit, 12 Channels, -40 to 105°C, 64-Pin LQFP (PM), Green (RoHS and no Sb/Br), Tape and Reel	PM0064A	TM4C123GH6PMT R	Texas Instruments
U7	1		2 A High Efficient Step Down Converter in 2x2 mm SON Package, DSG0008A (WSON-8)	DSG0008A	TLV62084ADSGR	Texas Instruments
U8, U9, U10	3		2.2-V to 36-V, microPower Comparator, DBV0005A (SOT-23-5)	DBV0005A	TLV1701AIDBVR	Texas Instruments
Y1	1		Crystal, 16 MHz, 8 pF, SMD	3.2x0.75x2.5 mm	NX3225GA-16.000M-STD-CRG-1	NDK
FID1, FID2, FID3, FID4, FID5, FID6	0		Fiducial mark. There is nothing to buy or mount.	N/A	N/A	N/A
J1	0		Header, 50 mil, 5x2, Gold, TH	Header, 5x2, 50 mil	GRPB052VWVN-RC	Sullins Connector Solutions
R17, R18	0	10.2k	RES, 10.2 k, 1%, 0.05 W, 0201	0201	RC0201FR-0710K2L	Yageo America

IMPORTANT NOTICE AND DISCLAIMER

TI PROVIDES TECHNICAL AND RELIABILITY DATA (INCLUDING DATA SHEETS), DESIGN RESOURCES (INCLUDING REFERENCE DESIGNS), APPLICATION OR OTHER DESIGN ADVICE, WEB TOOLS, SAFETY INFORMATION, AND OTHER RESOURCES "AS IS" AND WITH ALL FAULTS, AND DISCLAIMS ALL WARRANTIES, EXPRESS AND IMPLIED, INCLUDING WITHOUT LIMITATION ANY IMPLIED WARRANTIES OF MERCHANTABILITY, FITNESS FOR A PARTICULAR PURPOSE OR NON-INFRINGEMENT OF THIRD PARTY INTELLECTUAL PROPERTY RIGHTS.

These resources are intended for skilled developers designing with TI products. You are solely responsible for (1) selecting the appropriate TI products for your application, (2) designing, validating and testing your application, and (3) ensuring your application meets applicable standards, and any other safety, security, regulatory or other requirements.

These resources are subject to change without notice. TI grants you permission to use these resources only for development of an application that uses the TI products described in the resource. Other reproduction and display of these resources is prohibited. No license is granted to any other TI intellectual property right or to any third party intellectual property right. TI disclaims responsibility for, and you will fully indemnify TI and its representatives against, any claims, damages, costs, losses, and liabilities arising out of your use of these resources.

TI's products are provided subject to [TI's Terms of Sale](#) or other applicable terms available either on ti.com or provided in conjunction with such TI products. TI's provision of these resources does not expand or otherwise alter TI's applicable warranties or warranty disclaimers for TI products.

TI objects to and rejects any additional or different terms you may have proposed.

Mailing Address: Texas Instruments, Post Office Box 655303, Dallas, Texas 75265
Copyright © 2022, Texas Instruments Incorporated