

## **AN-2014 LMH2110 Evaluation Board**

---

---

---

### **General Description**

The evaluation board is designed to help the evaluation of the Texas Instruments LMH2110, which is a 45 dB Logarithmic RMS power detector particularly suited for accurate power measurement of modulated RF signals that exhibit large peak-to-average ratios, that is, large variations of the signal envelope. Such signals are encountered in W-CDMA and LTE cell phones. The RMS measurement topology inherently ensures a modulation insensitive measurement.

The device has an RF frequency range from 50 MHz to 8 GHz. It provides an accurate, temperature and supply insensitive, output voltage that relates linearly to the RF input power in dBm. The LMH2110's excellent conformance to a logarithmic response enables an easy integration by using slope and intercept only, reducing calibration effort significantly. The device operates with a single supply from 2.7V to 5V. The LMH2110 has an RF power detection range from -40 dBm to 5 dBm and is ideally suited for use in combination with a directional coupler. Alternatively a resistive divider can be used as well.

The device is active for EN = High, otherwise it is in a low power consumption shutdown mode. To save power and prevent discharge of an external filter capacitance, the output (OUT) is high-impedance during shutdown.

The LMH2110 power detector is offered in a tiny 6-bump DSBGA package.

[LMH2110 Evaluation Board](#) shows the LMH2110 Evaluation Board.

### **Basic Operation**

The circuit operates with a single supply from 2.7V to 5V and has an RF power detection range from -40 dBm to 5 dBm. The board consists of a single LMH2110 along with external components soldered on a printed circuit board. External supply voltages and input signals can be applied to the on-board connectors. The supply voltage is applied with connectors P21 (VDD) and P22 (GND). The RF input signal is applied by SMA connector P1. This RF signal is applied through an RF generator and is connected with a 50Ω SMA cable. The detector output can be measured via BNC connector P3.

### **Configuration**

The LMH2110 evaluation board can be configured via jumper settings. The device is active when EN = High. This can be accomplished by setting the jumper J4 to VDD or by using external control on P4 by setting the jumper J4 to EN. Since the device has an internal operating voltage of 2.5V, the voltage level on the enable should not be higher than 3V to prevent damage to the device. Also enable voltage levels lower than 400 mV below GND should be prevented. In both cases the ESD devices start to conduct when the enable voltage range is exceeded and excessive current will be drawn. To guarantee a correct operation a voltage divider formed by R2 and R3 is present on the evaluation board. The absolute maximum ratings are also exceeded when the enable (EN) is switched to HIGH (from shutdown to active mode) while the supply voltage is switched off. This situation should be prevented at all times. A solution to protect the device is the resistor R1 of 1 kΩ in series with the enable input to limit the current.

An overview of the various jumper positions on the board is given in [Jumper Positions](#). The settings of these jumpers and their functions are listed in [Jumper and Header Overview](#).

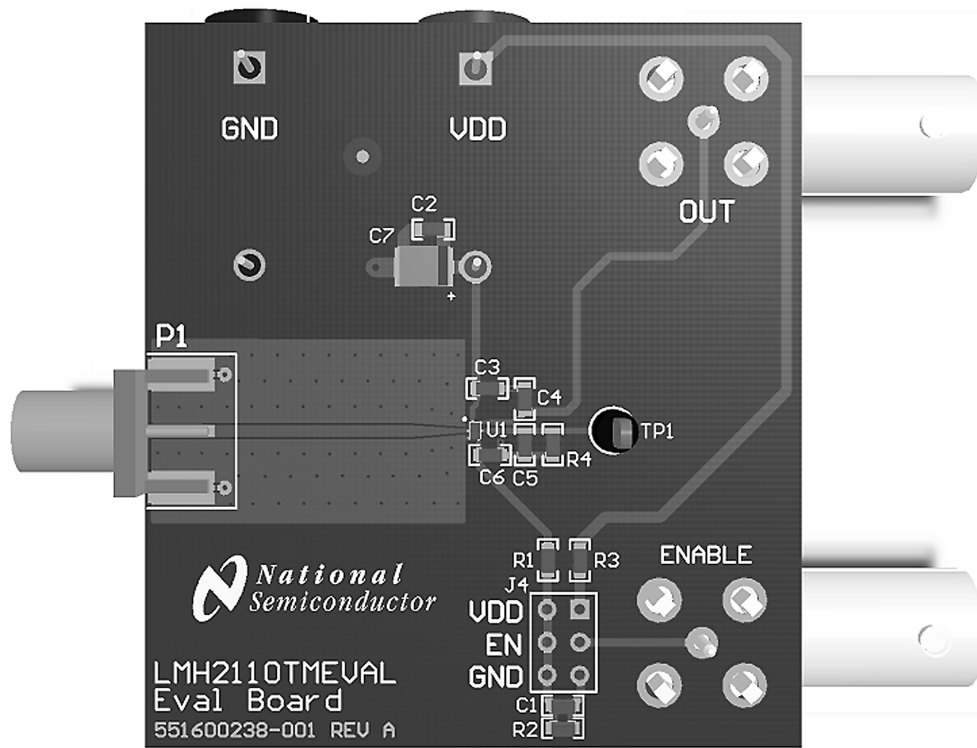

LMH2110 Evaluation Board

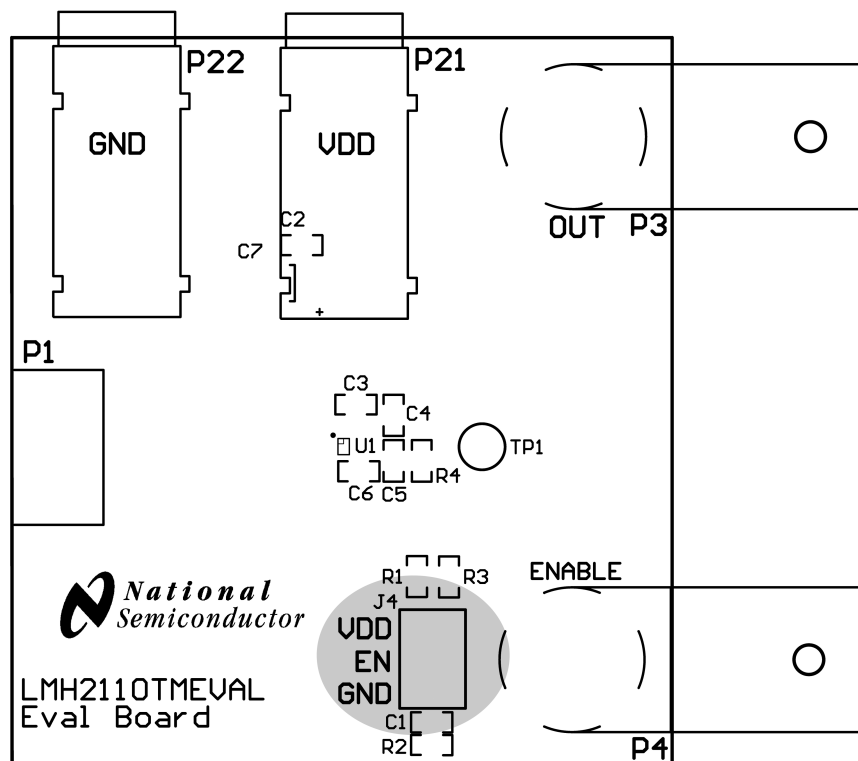

Jumper Positions

**Jumper and Header Overview**

<b>Jumper</b>	<b>Function</b>	<b>Jumper Position</b>	<b>Description</b>
J4	Enable	1-2	Active, Connects Enable Pin to VDD (factory default configuration)
		3-4	External Control, Connects Enable Pin to Enable P4
		5-6	Shutdown, Connects Enable Pin to GND

**Schematic**

The schematic of the evaluation board is shown in [Evaluation Board Schematic](#).

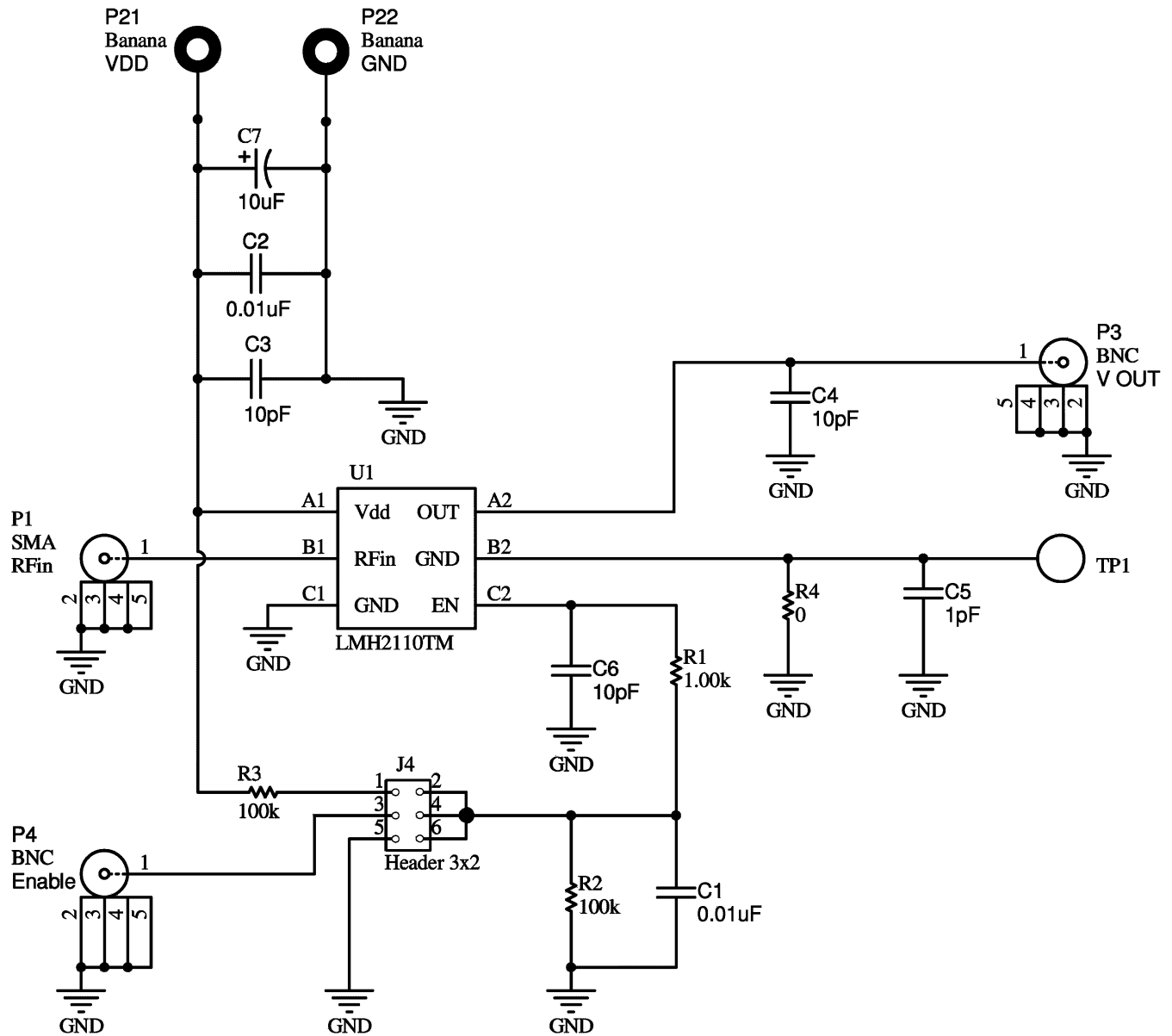

**Evaluation Board Schematic**

## Bill of Materials

The Bill of Material (BOM) of the evaluation board is listed in [Bill of Materials of the Evaluation Board](#).

### Bill of Materials of the Evaluation Board

Designator	Description	Comment
C1, C2	0603 Capacitor	10 nF
C3, C4, C6	0603 Capacitor	10 pF
C5	0603 Capacitor	1 pF
C7	0603 Capacitor	10 $\mu$ F
J4	Header	2x3
P1	Connector	SMA
P21, P22	Connector	Banana
P3	Connector	BNC
P4	Connector	BNC
R1	0603 Resistor	1 k $\Omega$
R2, R3	0603 Resistor	100 k $\Omega$
R4	0603 Resistor	0 $\Omega$
TP1	Test Point	GND
U1	DSBGA	LMH2110

## Board Layout

As with any other RF device, careful attention must be paid to the board layout. If the board layout isn't properly designed, performance might be less than can be expected for the application. The LMH2110 is designed to be used in RF applications, having a characteristic impedance of 50 $\Omega$ . To achieve this impedance, the input of the LMH2110 needs to be connected via a 50 $\Omega$  transmission line. Transmission lines can be created on PCBs using microstrip or (grounded) coplanar waveguide (GCPW) configurations. In order to minimize injection of RF interference into the LMH2110 through the supply lines, the PCB traces for VDD and GND should be minimized for RF signals. This can be done by placing a small decoupling capacitor between the VDD and GND. It should be placed as close as possible to the VDD and GND pins of the LMH2110.

[Component Locations of Evaluation Board](#) shows the component locations of the LMH2110 evaluation board and [Board Layout of Evaluation Board](#) shows the board layout of the LMH2110 evaluation board.

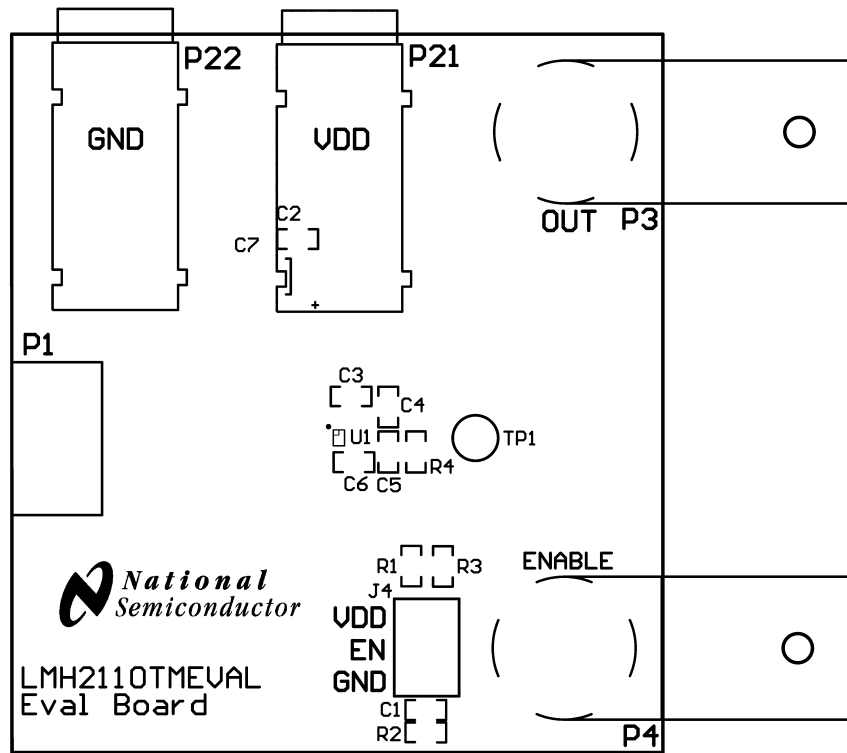

Component Locations of Evaluation Board

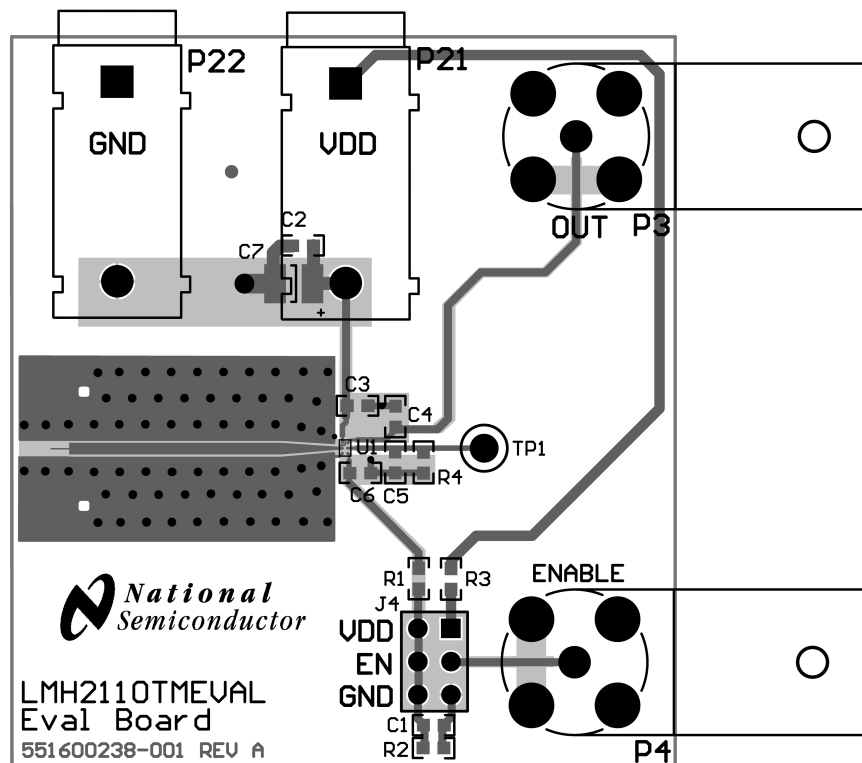

Board Layout of Evaluation Board

## Measurement Procedure

The performance of the LMH2110 can be measured with the setup shown in [Measurement Setup](#).

An external power supply provides a voltage of 2.7V to 5V to the evaluation board. An accurate and stable RF Signal Generator is used to produce the test signal. It is recommended to use low loss cables to ensure reliable measurement data. The detected output voltage can be measured with a Digital Voltage Meter (DVM).

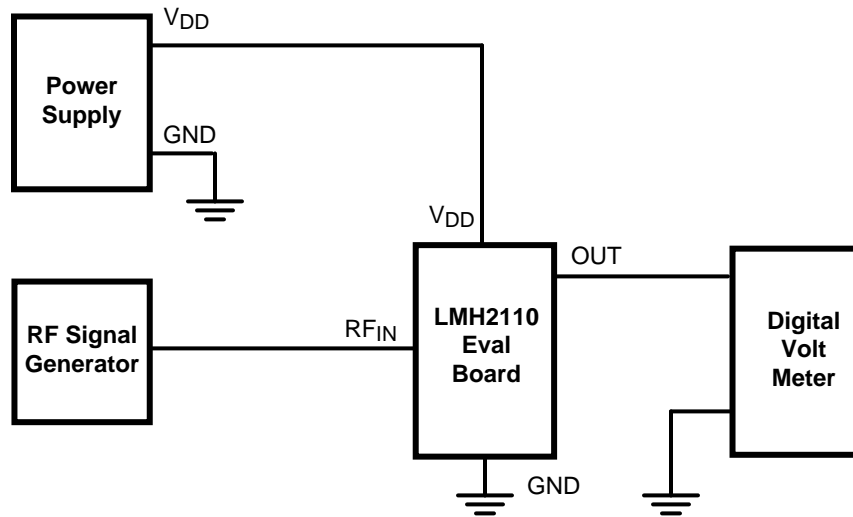

Measurement Setup

## 1 Measurement Results

Figure 1 shows the output voltage versus frequency for various power levels on  $RF_{IN}$ . The frequency range is from 10 MHz to 10 GHz. Figure 2 shows the output voltage versus RF input power for various frequencies.

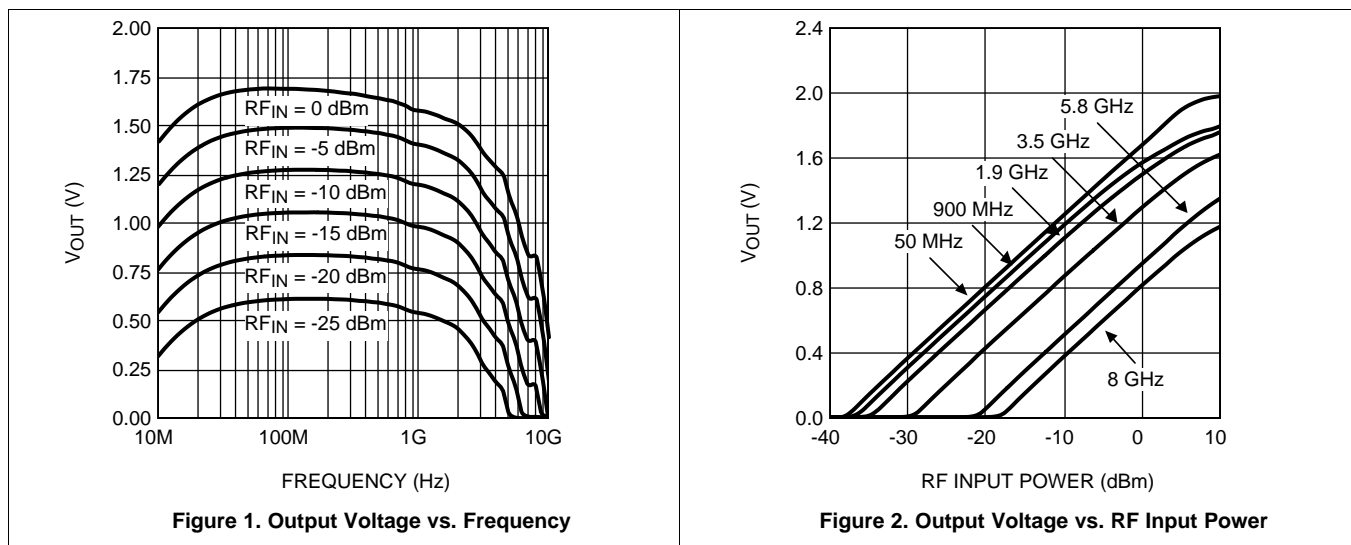

Figure 1. Output Voltage vs. Frequency

Figure 2. Output Voltage vs. RF Input Power

---

**Revision History****Changes from A Revision (April 2013) to B Revision** **Page**

- 
- Changed Figures 7 and 8 to correct for Y axis values placement ..... [7](#)
- 

NOTE: Page numbers for previous revisions may differ from page numbers in the current version.



## IMPORTANT NOTICE

Texas Instruments Incorporated and its subsidiaries (TI) reserve the right to make corrections, enhancements, improvements and other changes to its semiconductor products and services per JESD46, latest issue, and to discontinue any product or service per JESD48, latest issue. Buyers should obtain the latest relevant information before placing orders and should verify that such information is current and complete. All semiconductor products (also referred to herein as "components") are sold subject to TI's terms and conditions of sale supplied at the time of order acknowledgment.

TI warrants performance of its components to the specifications applicable at the time of sale, in accordance with the warranty in TI's terms and conditions of sale of semiconductor products. Testing and other quality control techniques are used to the extent TI deems necessary to support this warranty. Except where mandated by applicable law, testing of all parameters of each component is not necessarily performed.

TI assumes no liability for applications assistance or the design of Buyers' products. Buyers are responsible for their products and applications using TI components. To minimize the risks associated with Buyers' products and applications, Buyers should provide adequate design and operating safeguards.

TI does not warrant or represent that any license, either express or implied, is granted under any patent right, copyright, mask work right, or other intellectual property right relating to any combination, machine, or process in which TI components or services are used. Information published by TI regarding third-party products or services does not constitute a license to use such products or services or a warranty or endorsement thereof. Use of such information may require a license from a third party under the patents or other intellectual property of the third party, or a license from TI under the patents or other intellectual property of TI.

Reproduction of significant portions of TI information in TI data books or data sheets is permissible only if reproduction is without alteration and is accompanied by all associated warranties, conditions, limitations, and notices. TI is not responsible or liable for such altered documentation. Information of third parties may be subject to additional restrictions.

Resale of TI components or services with statements different from or beyond the parameters stated by TI for that component or service voids all express and any implied warranties for the associated TI component or service and is an unfair and deceptive business practice. TI is not responsible or liable for any such statements.

Buyer acknowledges and agrees that it is solely responsible for compliance with all legal, regulatory and safety-related requirements concerning its products, and any use of TI components in its applications, notwithstanding any applications-related information or support that may be provided by TI. Buyer represents and agrees that it has all the necessary expertise to create and implement safeguards which anticipate dangerous consequences of failures, monitor failures and their consequences, lessen the likelihood of failures that might cause harm and take appropriate remedial actions. Buyer will fully indemnify TI and its representatives against any damages arising out of the use of any TI components in safety-critical applications.

In some cases, TI components may be promoted specifically to facilitate safety-related applications. With such components, TI's goal is to help enable customers to design and create their own end-product solutions that meet applicable functional safety standards and requirements. Nonetheless, such components are subject to these terms.

No TI components are authorized for use in FDA Class III (or similar life-critical medical equipment) unless authorized officers of the parties have executed a special agreement specifically governing such use.

Only those TI components which TI has specifically designated as military grade or "enhanced plastic" are designed and intended for use in military/aerospace applications or environments. Buyer acknowledges and agrees that any military or aerospace use of TI components which have **not** been so designated is solely at the Buyer's risk, and that Buyer is solely responsible for compliance with all legal and regulatory requirements in connection with such use.

TI has specifically designated certain components as meeting ISO/TS16949 requirements, mainly for automotive use. In any case of use of non-designated products, TI will not be responsible for any failure to meet ISO/TS16949.

### Products

Audio	<a href="http://www.ti.com/audio">www.ti.com/audio</a>
Amplifiers	<a href="http://amplifier.ti.com">amplifier.ti.com</a>
Data Converters	<a href="http://dataconverter.ti.com">dataconverter.ti.com</a>
DLP® Products	<a href="http://www.dlp.com">www.dlp.com</a>
DSP	<a href="http://dsp.ti.com">dsp.ti.com</a>
Clocks and Timers	<a href="http://www.ti.com/clocks">www.ti.com/clocks</a>
Interface	<a href="http://interface.ti.com">interface.ti.com</a>
Logic	<a href="http://logic.ti.com">logic.ti.com</a>
Power Mgmt	<a href="http://power.ti.com">power.ti.com</a>
Microcontrollers	<a href="http://microcontroller.ti.com">microcontroller.ti.com</a>
RFID	<a href="http://www.ti-rfid.com">www.ti-rfid.com</a>
OMAP Applications Processors	<a href="http://www.ti.com/omap">www.ti.com/omap</a>
Wireless Connectivity	<a href="http://www.ti.com/wirelessconnectivity">www.ti.com/wirelessconnectivity</a>

### Applications

Automotive and Transportation	<a href="http://www.ti.com/automotive">www.ti.com/automotive</a>
Communications and Telecom	<a href="http://www.ti.com/communications">www.ti.com/communications</a>
Computers and Peripherals	<a href="http://www.ti.com/computers">www.ti.com/computers</a>
Consumer Electronics	<a href="http://www.ti.com/consumer-apps">www.ti.com/consumer-apps</a>
Energy and Lighting	<a href="http://www.ti.com/energy">www.ti.com/energy</a>
Industrial	<a href="http://www.ti.com/industrial">www.ti.com/industrial</a>
Medical	<a href="http://www.ti.com/medical">www.ti.com/medical</a>
Security	<a href="http://www.ti.com/security">www.ti.com/security</a>
Space, Avionics and Defense	<a href="http://www.ti.com/space-avionics-defense">www.ti.com/space-avionics-defense</a>
Video and Imaging	<a href="http://www.ti.com/video">www.ti.com/video</a>

### TI E2E Community

[e2e.ti.com](http://e2e.ti.com)