



TI Designs

This TI Design uses Texas Instruments SimpleLink™ Wi-Fi CC3200 Internet-on-a-chip™ Wireless MCU module to create a data bridge between an RS-485 network and a Wi-Fi network. An SN65HVD72 transceiver provides the RS-485 interface with 12 kV of ESD protection, and additional protection is provided on board. The design can be powered with AC or DC power up to 30-V_{RMS} or 48-V peak.

A version of this design with an isolated RS-485 interface is presented in TIDA-00486.

Design Resources

TIDA-00485	Design Folder
CC3200MOD	Product Folder
LM5160	Product Folder
SN65HVD72D	Product Folder
TPD1E10B06	Product Folder

Design Features

- Add Wi-Fi Connectivity to an RS-485 Network Quickly and Simply
- CC3200 Application Processor Provides Adaptability to Customer Communication Protocols
- Wide Input Voltage Range of 18-V to 30-V AC, 12-V to 48-V DC

Featured Applications

- Building Automation
- Thermostats
- Compressors
- HVAC



[ASK Our E2E Experts](#)
[WEBENCH® Calculator Tools](#)

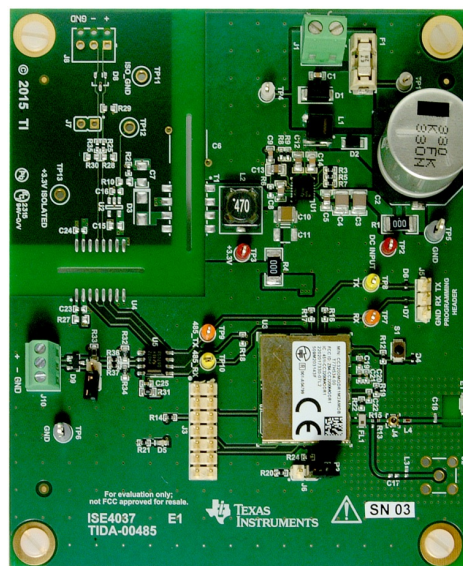
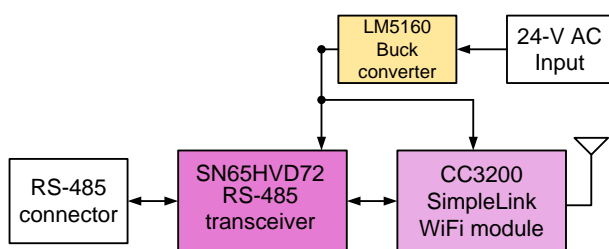

An IMPORTANT NOTICE at the end of this TI reference design addresses authorized use, intellectual property matters and other important disclaimers and information.

1 Key System Specifications

Table 1. Key System Specifications

PARAMETER	SPECIFICATION	DETAILS
Input voltage	24 V Nominal, AC or DC	See Section 7.1 , Section 7.2
	15-V to 48-V DC	
	24-V AC + 25%	
Power connector	Screw terminals	See Section 4.1
Interface	RS-485	See Section 4.4
RS-485 connector	Screw terminals	See Section 4.4

2 System Description

The TIDA-00485 reference design is an RS-485 to Wi-Fi Bridge that is powered by 24-V AC nominally. The input voltage can range from 15-V to 48-V DC or 18-V_{RMS} to 30-V_{RMS} AC. It is intended for use with industrial and building automation systems that need to add Wi-Fi capability to an existing RS-485 network. The RS-485 to Wi-Fi Bridge can be used as a cable replacement or to add new functions to an existing network. This reference design has a half-wave rectifier, input voltage filter, and a 3.3-V output step-down regulator to supply the primary system voltage. The system ground is suitable for use in AC systems that use a system or earth ground for one of the AC power connections.

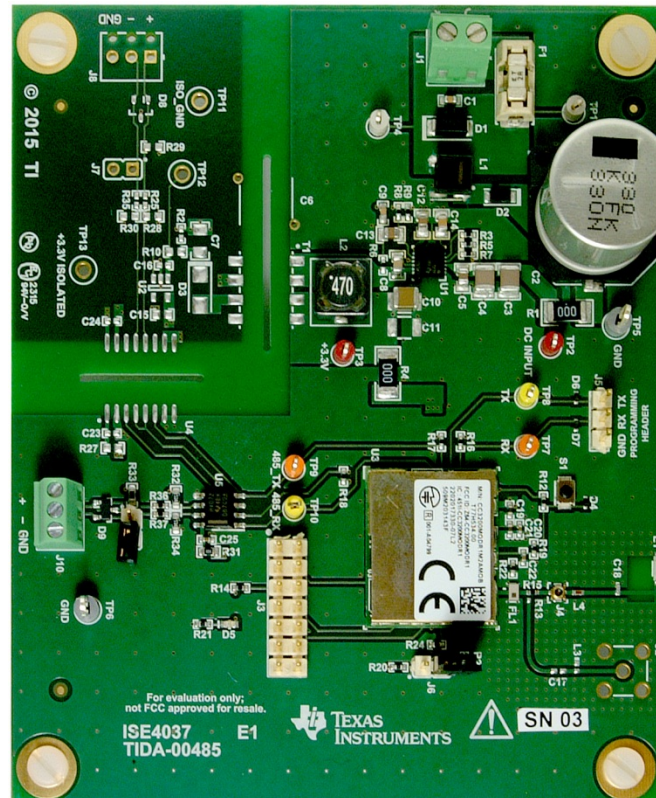

Figure 1. RS-485 to Wi-Fi Bridge with 24-V AC Power

3 Block Diagram

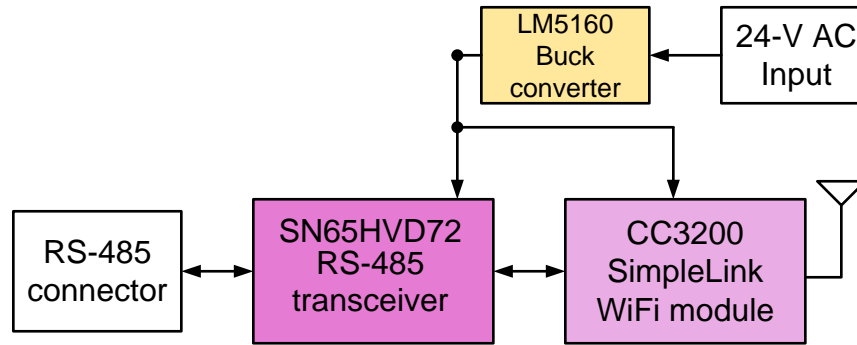

Figure 2. TIDA-00485 Block Diagram

3.1 Highlighted Products

3.1.1 CC3200MOD SimpleLink Wi-Fi and Internet-of-Things Module Solution, a Single-Chip Wireless MCU

This device is the industry's first programmable FCC, IC, CE, and Wi-Fi Certified Wireless microcontroller (MCU) module with built-in Wi-Fi connectivity. Created for the Internet of Things (IoT), the SimpleLink CC3200MOD is a wireless MCU module that integrates an ARM® Cortex®-M4 MCU, allowing customers to develop an entire application with a single device. With on-chip Wi-Fi, internet, and robust security protocols, no prior Wi-Fi experience is required for faster development. The CC3200MOD integrates all required system-level hardware components including clocks, SPI flash, RF switch, and passives into an LGA package for easy assembly and low-cost PCB design. The CC3200MOD is provided as a complete platform solution including software, sample applications, tools, user and programming guides, reference designs, and the TI E2E support community.

The applications MCU subsystem contains an industry-standard ARM Cortex-M4 core running at 80 MHz.

The device includes a wide variety of peripherals, including a fast parallel camera interface, I2S, SD/MMC, UART, SPI, I²C, and four-channel ADC. The CC3200 family includes flexible embedded RAM for code and data; ROM with external serial flash bootloader and peripheral drivers; and SPI flash for Wi-Fi network processor service packs, Wi-Fi certificates, and credentials.

The Wi-Fi network processor subsystem features a Wi-Fi Internet-on-a-chip and contains an additional dedicated ARM MCU that completely off-loads the applications MCU. This subsystem includes an 802.11 b/g/n radio, baseband, and MAC with a powerful crypto engine for fast, secure Internet connections with 256-bit encryption. The CC3200MOD supports station, access point, and Wi-Fi Direct™ modes. The device also supports WPA2 personal and enterprise security and WPS 2.0. The Wi-Fi Internet-on-a-chip includes embedded TCP/IP and TLS/SSL stacks, HTTP server, and multiple Internet protocols. The power-management subsystem includes integrated DC-DC converters supporting a wide range of supply voltages. This subsystem enables low-power consumption modes, such as the hibernate with RTC mode requiring less than 7 µA of current.

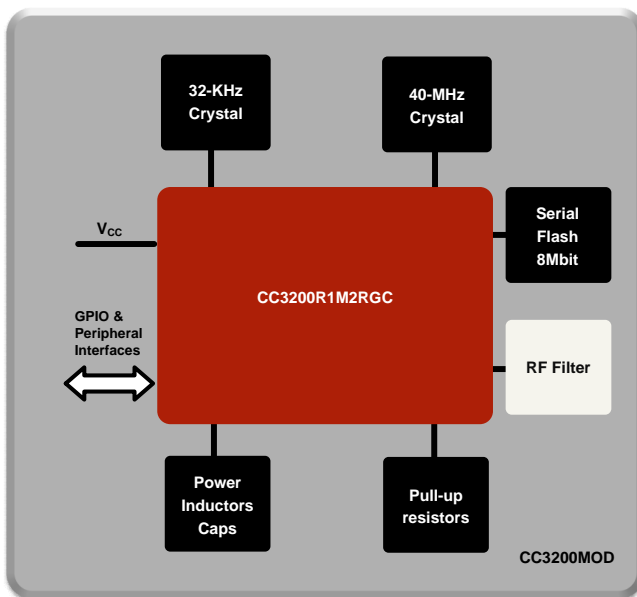

Figure 3. CC3200MOD Functional Block Diagram

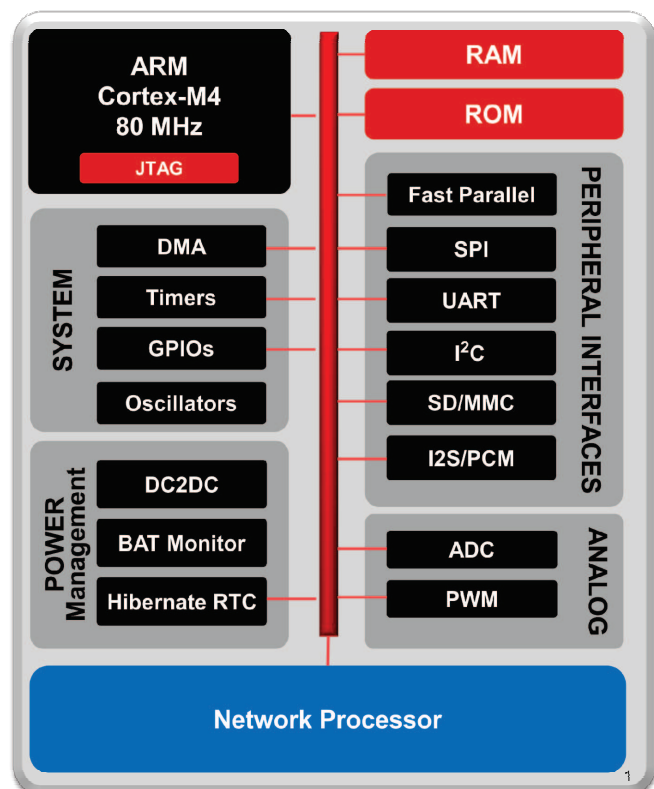

Figure 4. CC3200 Hardware Overview

3.1.2 LM5160 Wide Input 65-V, 1.5-A Synchronous Step-Down DC-DC Converter

The LM5160 family is a 65-V, 1.5-A synchronous step-down converter with integrated high-side and step-down converter with integrated high-side and scheme requires no loop compensation and supports high step-down ratios with fast transient response. An internal feedback amplifier maintains $\pm 1\%$ output voltage regulation over the entire operating temperature range. The on-time varies inversely with input voltage resulting in nearly constant switching frequency. Peak and valley current limit circuits protect against overload conditions. The undervoltage lockout (EN/UVLO) circuit provides independently adjustable input undervoltage threshold and hysteresis. The LM5160 is programmed through the FPWM pin to operate in full load or to automatically switch to discontinuous conduction mode (DCM) at light load for higher efficiency. Forced CCM operation supports multiple output and isolated Fly-Buck™ applications using a coupled inductor.

The LM5160A shares the same features and pin configuration as the LM5160. An external bias supply can be connected to the VCC pin of the LM5160A in either Buck or Fly-Buck applications. This additional capability can improve efficiency at high input voltages.

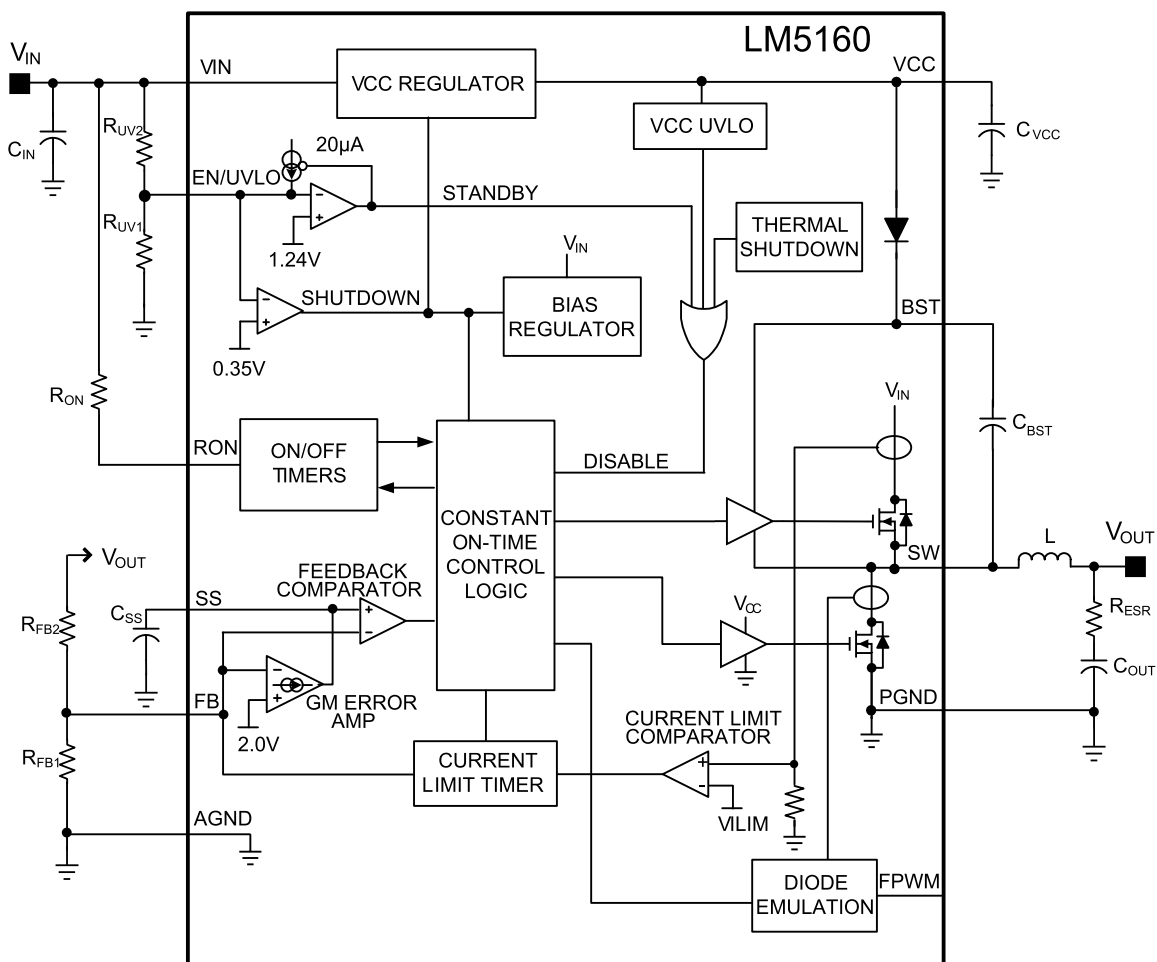

Figure 5. LM5160 Functional Block Diagram

3.1.3 SN65HVD72 3.3 V, Half-Duplex RS-485, 12-kV IEC ESD, 250-kbps Data Rate

These devices have robust 3.3V drivers and receivers in a small package for demanding industrial applications. The bus pins are robust to ESD events, with high levels of protection to Human-Body Model and IEC Contact Discharge specifications.

These devices each combine a differential driver and a differential receiver, which operate from a single 3.3-V power supply. The driver differential outputs and the receiver differential inputs are connected internally to form a bus port suitable for half-duplex (two-wire bus) communication. These devices all feature a wide common-mode voltage range making the devices suitable for multi-point applications over long cable runs. These devices are characterized from -40°C to 125°C .

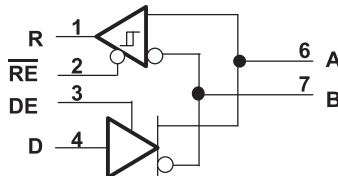

Figure 6. SN65HVD72 Logic Diagram

3.1.4 TPD1E10B06 Single Channel ESD in 0402 Package With 10-pF Capacitance and 6-V Breakdown

The TPD1E10B06 device is a single-channel electrostatic discharge (ESD) transient voltage suppression (TVS) diode in a small 0402 package. This TVS protection product offers $\pm 30\text{-kV}$ contact ESD, $\pm 30\text{-kV}$ IEC air-gap protection, and has an ESD clamp circuit with a back-to-back TVS diode for bipolar or bidirectional signal support. The 12-pF line capacitance of this ESD protection diode is suitable for a wide range of applications supporting data rates up to 400 Mbps. The 0402 package is an industry standard and is convenient for component placement in space-saving applications.

Typical applications of this ESD protection product are circuit protection for audio lines (microphone, earphone, and speaker phone), SD interfacing, keypad or other buttons, VBUS pin and ID pin of USB ports, and general-purpose I/O ports. This ESD clamp is good for the protection of the end equipment like ebooks, tablets, remote controllers, wearables, set-top boxes, and electronic point of sale equipment.

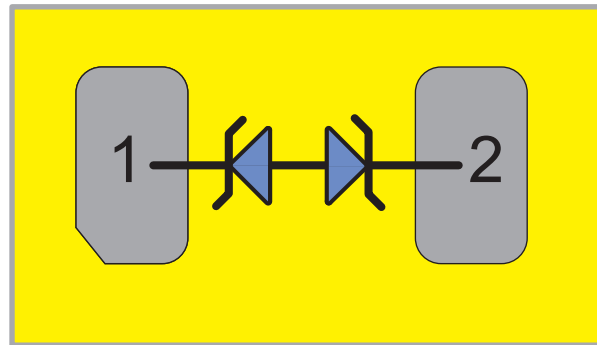

Figure 7. TPD1E10B06 Device Configuration

4 System Design Theory

The TIDA-00485 reference design has two primary circuit functions: converting a 24-V AC or DC input to 3.3-V DC and converting RS-485 traffic to Wi-Fi traffic.

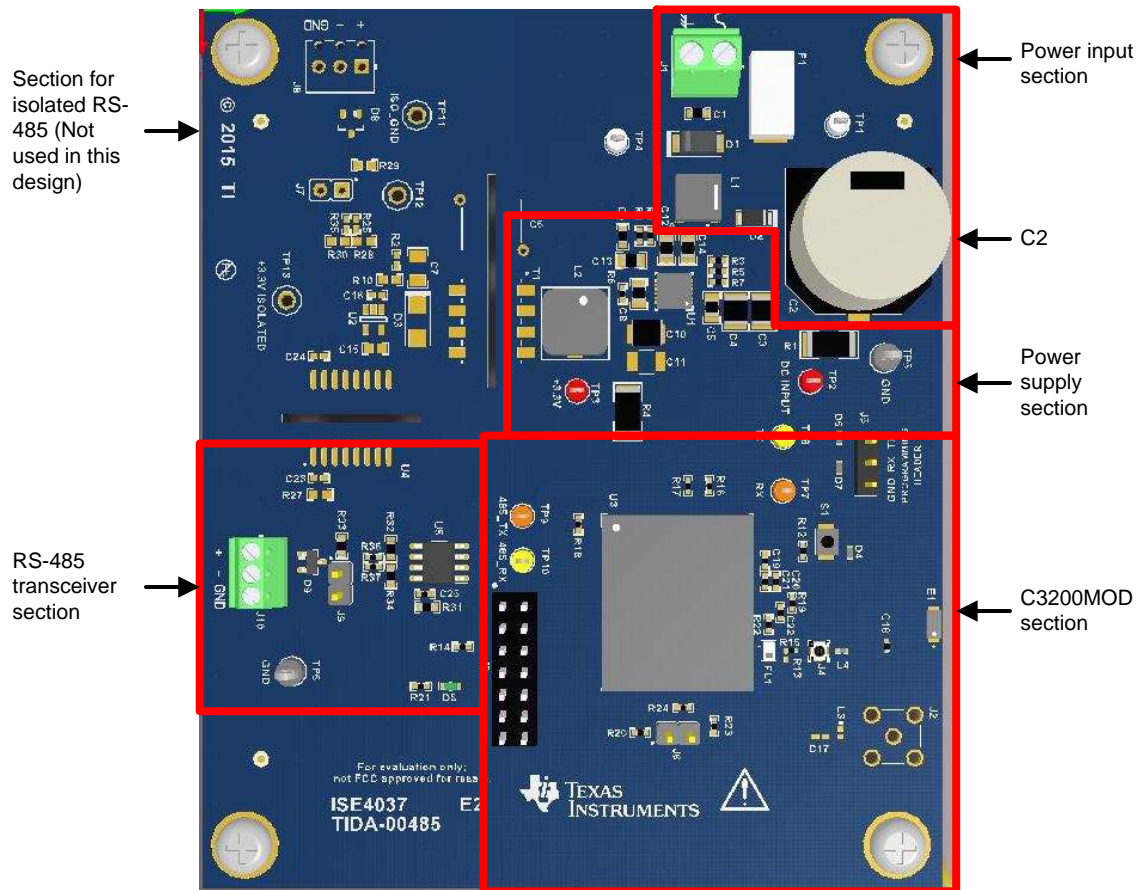

Figure 8. RS-485 to Wi-Fi Bridge Board Partitioning

4.1 Power Input

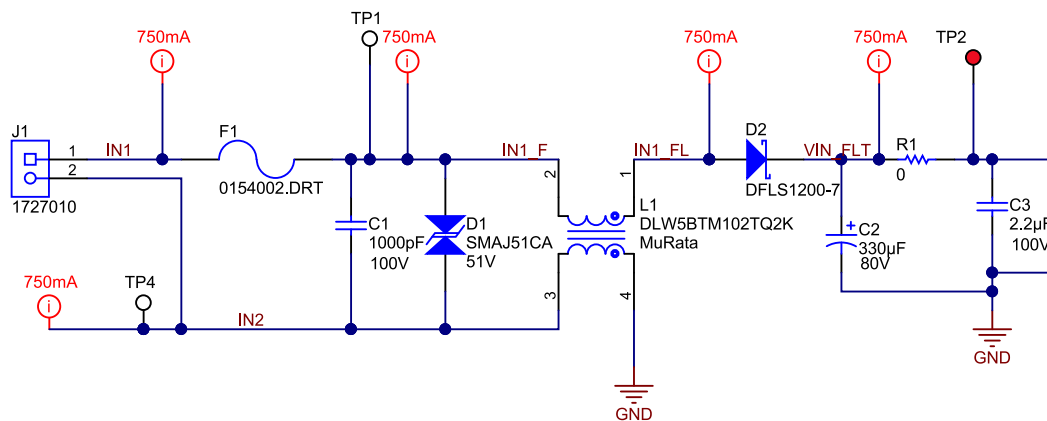

Figure 9. Power Input Schematic

D2 is a rectifier to convert the AC input to DC for use by the step-down regulator. D1 is a transient absorber with a 51-V break-down voltage, which limits the input voltage range to 51 V. C1 and L1 form an input filter to reduce conducted RF both into and out of the system. L1 is a common-mode choke. C1 is included to further reduce high frequency signal content. C2 is a 330- μ F, 80-V aluminum electrolytic capacitor provided to maintain the DC voltage between the AC voltage peaks. The value of the capacitor was determined by estimating the voltage input to the regulator when the input voltage is at its minimum or $18 V_{RMS}$ (peak voltage = 25.45 V) while the load is the estimated maximum of 600 mA at 3.3 V with an estimated power supply efficiency of 60%. Figure 10 shows the rectified input voltage as well as the estimated voltage on C2 when the load is at its maximum.

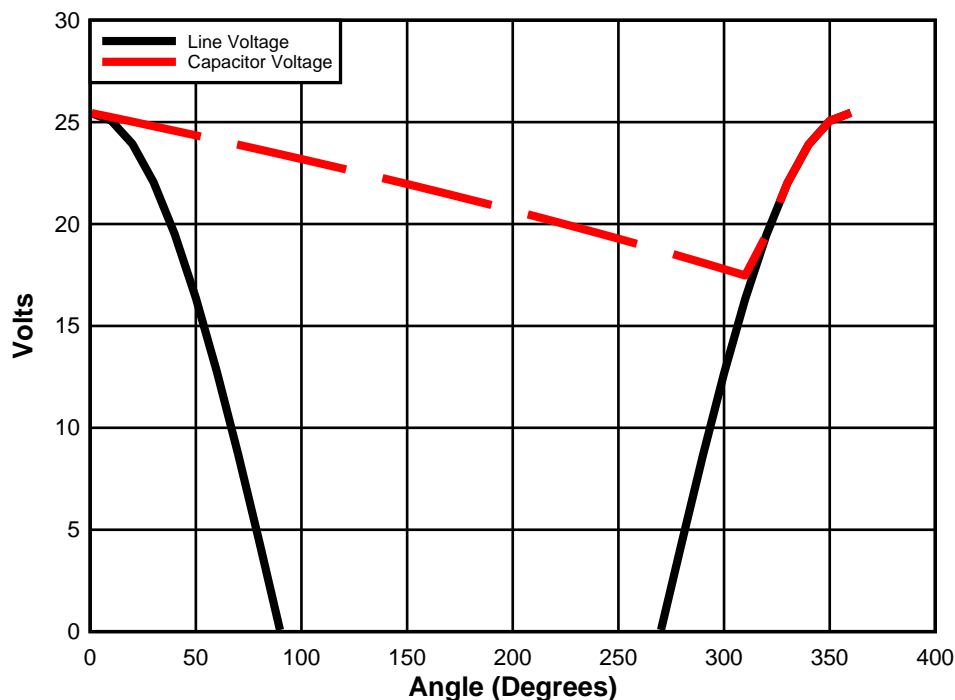

Figure 10. Estimate of Rectified DC Voltage Sag at Maximum Power

This value of C2 insures that the input voltage to the LM5160 power supply is above 15 V even when the input voltage is at its lowest rated value. Figure 10 was calculated for a 60-Hz power input.

4.2 3.3-V Power Supply

The 3.3-V power supply is provided by the LM5160. The LM5160 was chosen for this design due to its flexibility. The design of the RS-485 to Wi-Fi Bridge is actually two designs, one with a galvanically isolated RS-485 interface and one without isolation. TI Design TIDA-00485 is the non-isolated version and TIDA-00486 is the isolated version. The power supply design is easily convertible between the two designs by simply swapping L2 for T1.

The CC3200MOD has its maximum current load of 450 mA when the input voltage is 3.3 V. This occurs during CC3200 calibration at power on. The maximum load during data transmission is typically less than 300 mA. To insure there is enough power supply capacity for the RS-485 transceiver and the application processor, the design load current was chosen to be 600 mA.

The design procedure for the LM5160 uses the [LM5160 Buck Regulator Quick Start Calculator](#) spreadsheet linked to on the LM5160 product page. There are spreadsheets to design either a buck converter or a Fly-Buck converter. Both were used for the design of this circuit board. This document will only present the LM5160 buck regulator version of the design.

Design parameters used in the LM5160 buck design spreadsheet are as follow:

Table 2. Power Supply Design Spreadsheet Input Parameters

Desired output voltage	3.3 V
Minimum input voltage	10 V
Nominal input voltage	24 V
Maximum input voltage	65 V
Maximum load current	600 mA
Desired V_{in} , rising threshold	10 V
Desired V_{in} hysteresis	2.5 V
Select the value of R_{UV2}	127 k Ω
Select the value of R_{UV1}	18.2 k Ω
Select the value of R_{FB1}	3 k Ω
Select the value of R_{FB2}	1.96 k Ω
Desired nominal switching frequency	300 kHz
Select the value of R_{ON2}	110 k Ω
Select the value for L	47 μ H

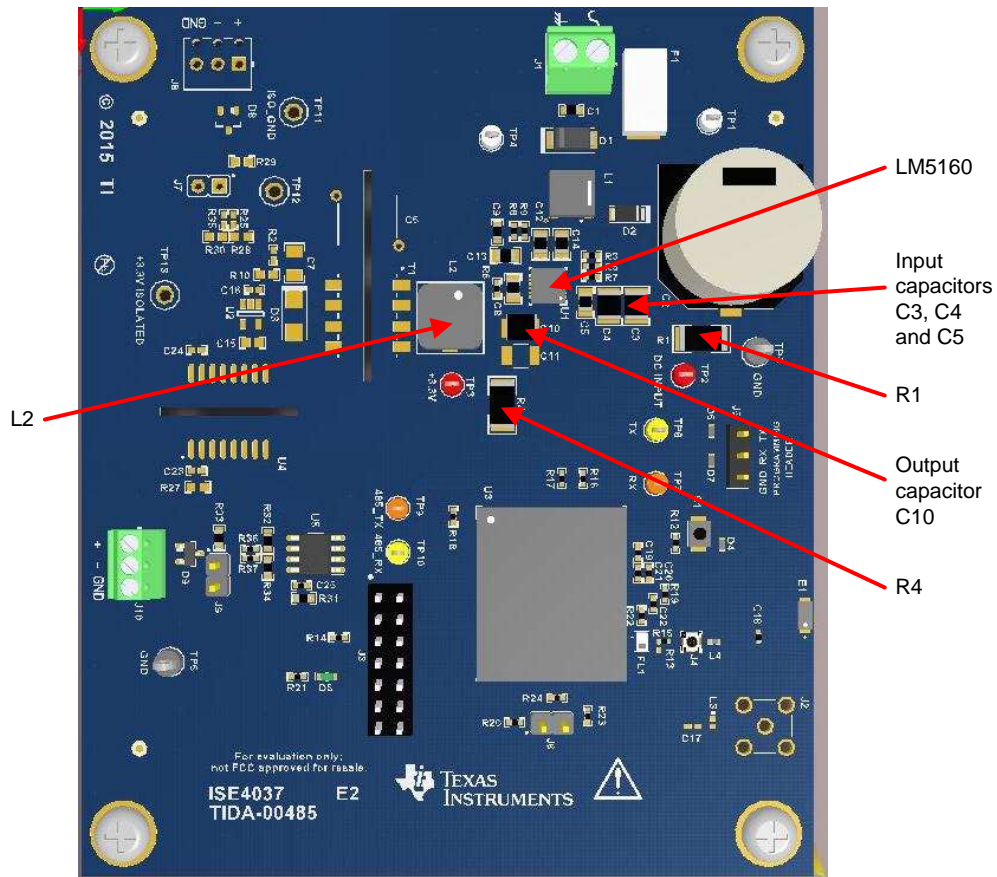

Figure 11. Power Supply Major Components

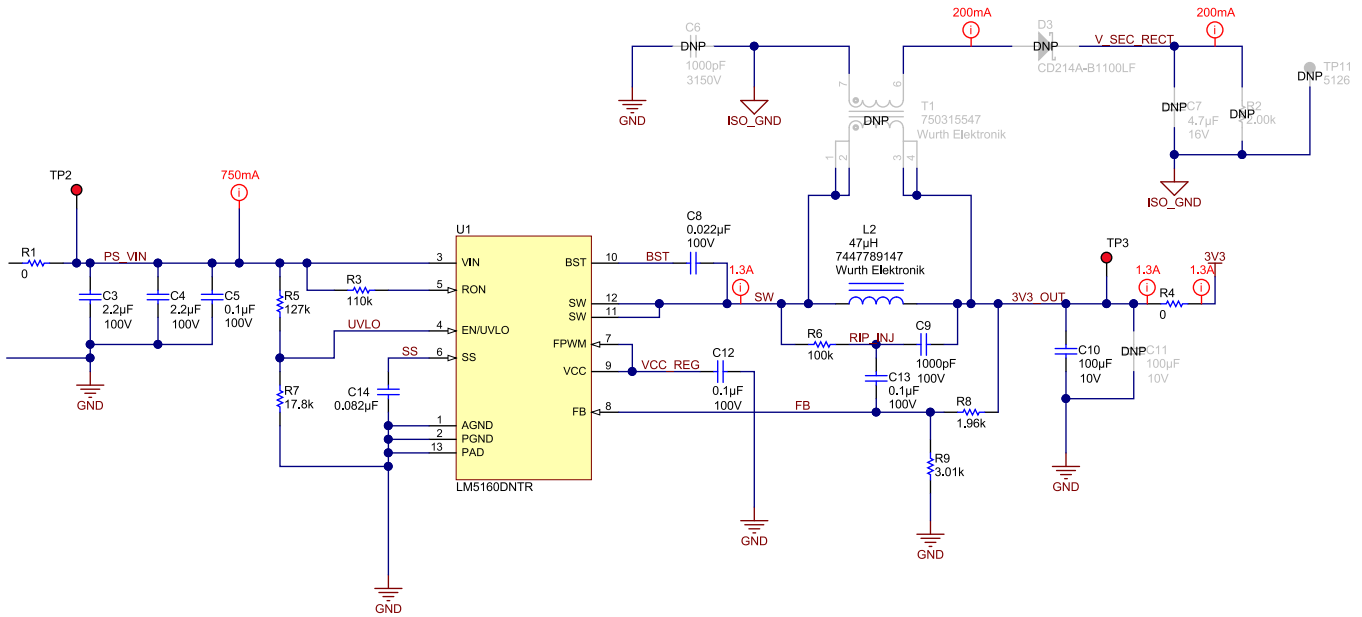

Figure 12. Power Supply Schematic

The output ripple configuration was chosen as type 3 for this design since type 3 is required for a Fly-Buck regulator. The spreadsheet gives values for the various capacitors around the LM5160 such as the boost capacitor C8; the VCC capacitor C12; the soft-start capacitor C14; the values of the ripple components R6, C9 and C13; the input capacitors C3 and C4; and output capacitors C10 and C11. C10 has been set to 100 µF to comply with the design requirements for the CC3200MOD, which asks for two 100-µF capacitors. C11 is left unpopulated in case the second 100 µF is needed. R1 and R4 are provided to allow easy current measurements for power supply efficiency measurements. T1 and the components for the Fly-Buck design are grayed out in the schematic for they are not populated in this version of the design.

4.3 CC3200MOD

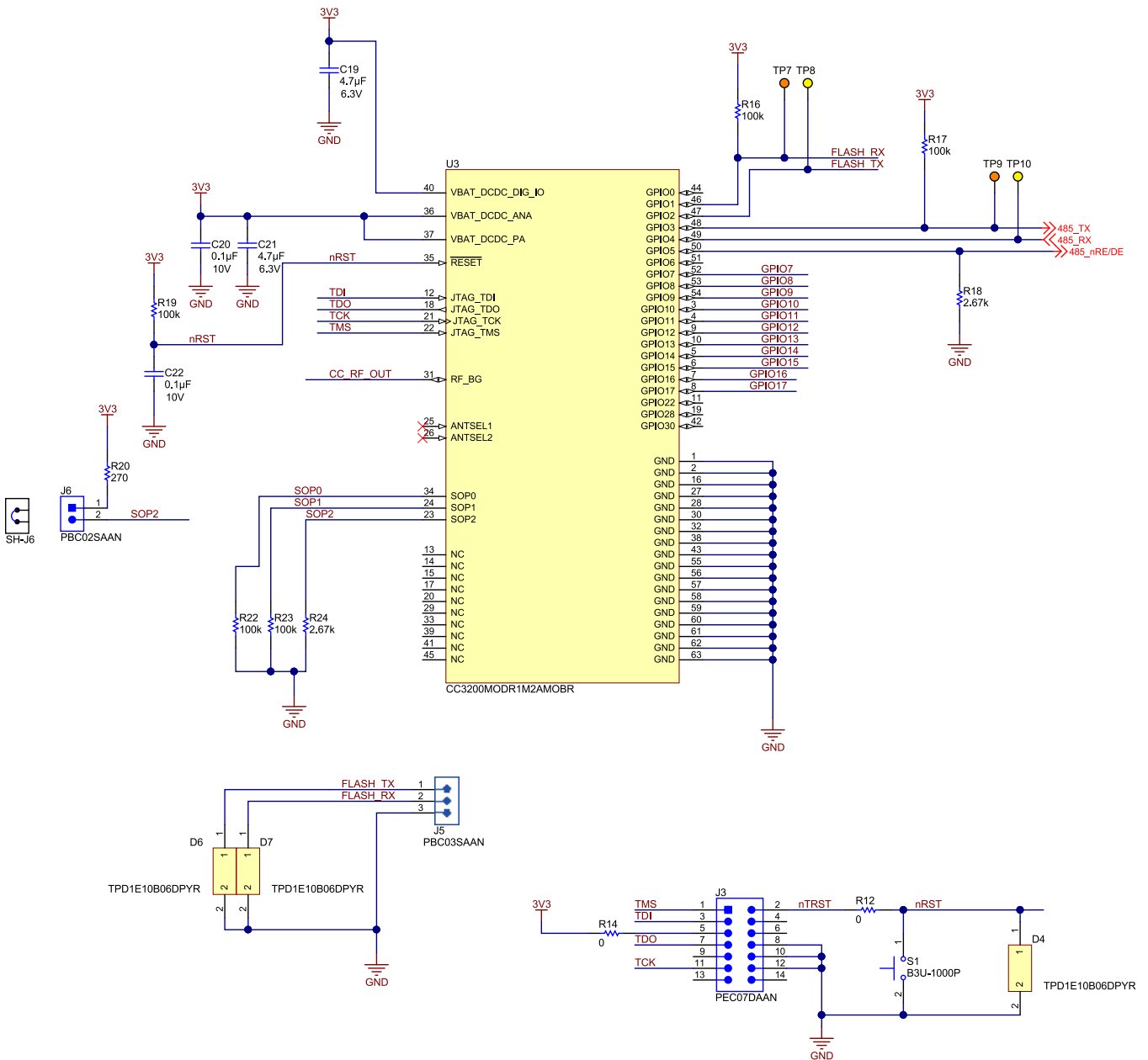

Figure 13. CC3200MOD Schematic

The CC3200MOD is an easy-to-use module that contains the serial memory and crystals required for a CC3200-based system. The only external components are the necessary bypass capacitors and pull-down resistors. There are two UART interfaces. One UART interface is used for system programming and another is used for RS-485 communication.

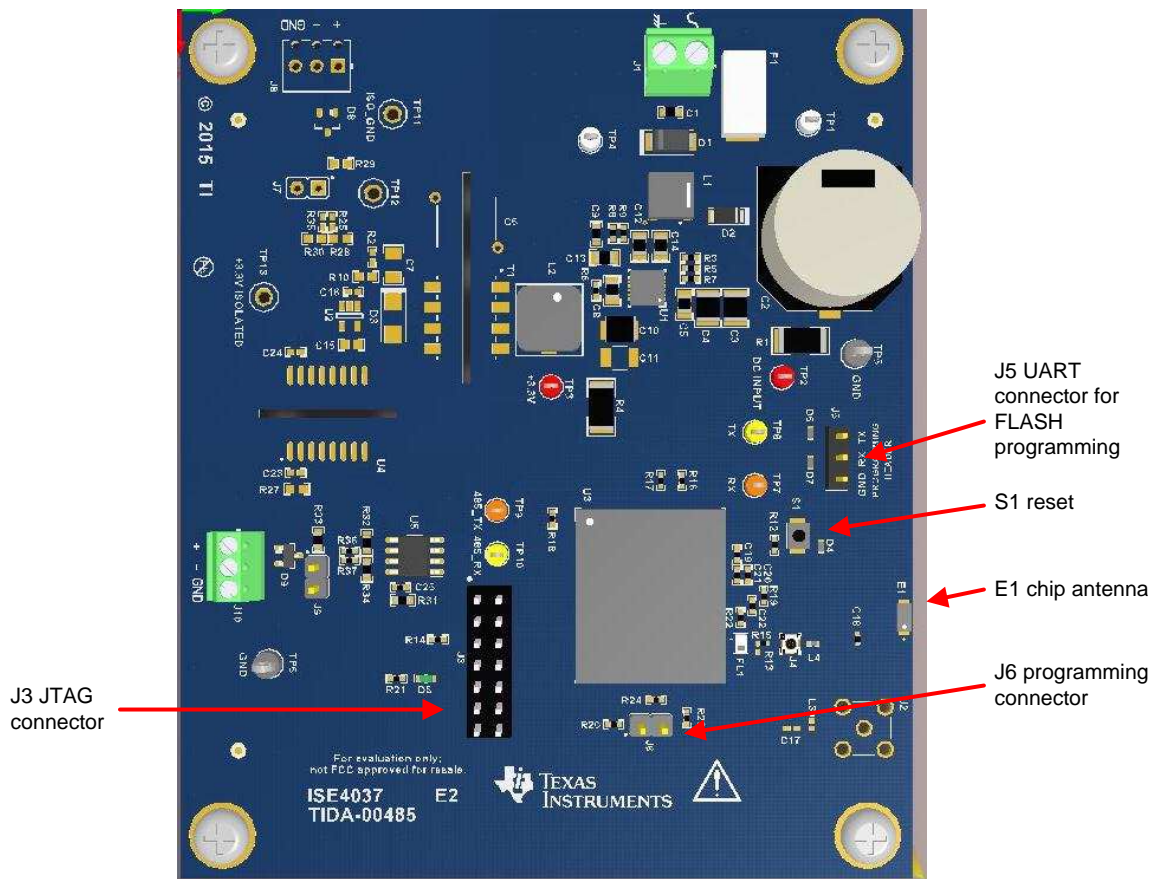

Figure 14. CC3200 Interface Connectors

There are several connectors provided for test and expansion. J6 is provided for FLASH programming. J6 is shorted for programming operations and is left open during normal operation. J3 is a JTAG connector for system debugging. It follows the TI 14-pin JTAG format. Connector J5 is a three-pin header that connects to the UART0 pins of the CC3200MOD to allow FLASH reprogramming with the Code Composer Studio™ (CCS) UniFlash™ tool and a USB-to-UART converter. The RESET button S1 provides a manual reset capability. Diodes D4 through D7 provide ESD protection for the UART connection and the reset.

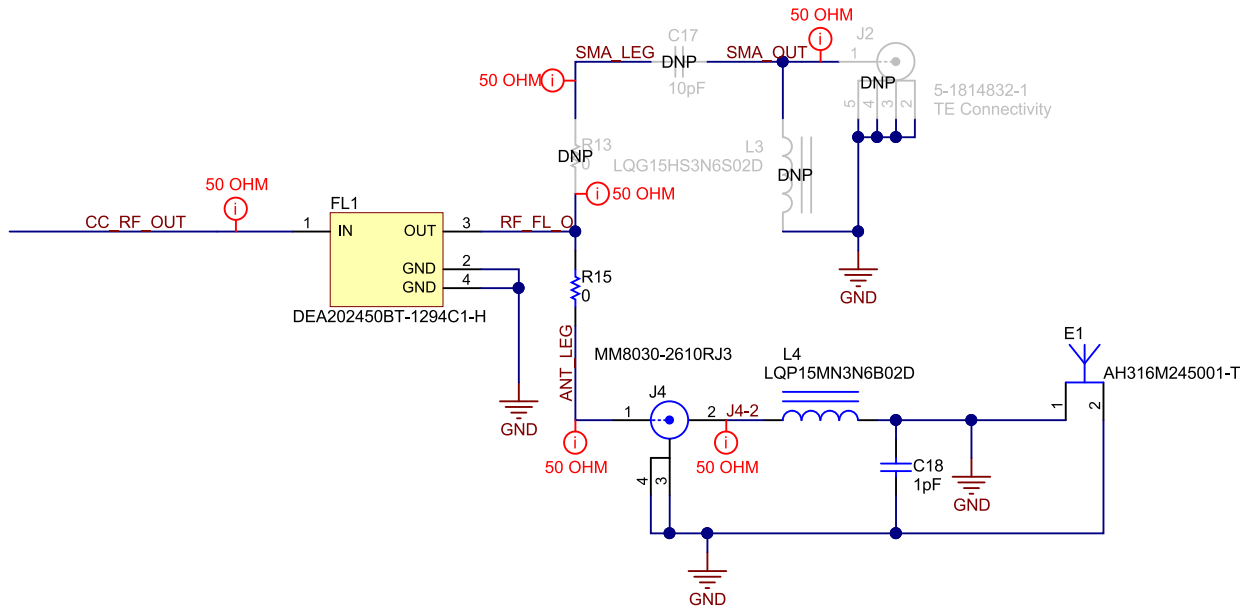

Figure 15. Antenna Section Schematic

The RF antenna output section has two antenna options. The PCB is populated with the parts for the onboard chip antenna E1. Connector J4 is an RF test connector. J2 is an SMA connector for use with an external antenna. Components associated with the J2 path are not populated. To use the SMA connector, R15 should be removed and components R13, C17, and L3 installed. Choose actual values for C17 and L3 based on the signal matching requirements of the antenna to be connected to J2.

4.4 RS-485 Interface

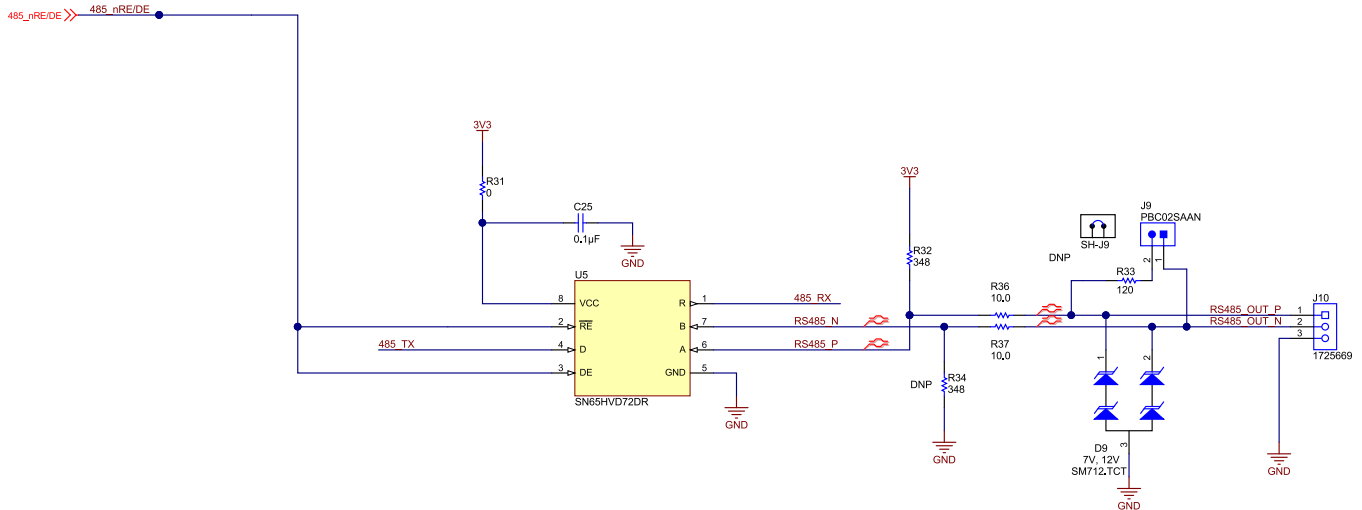

Figure 16. RS-485 Transceiver

The RS-485 transceiver is a TI SN65HVD72, which operates with a 3.3-V power supply. J10 is a screw-terminal connector with the RS-485 + and – connections and system ground. D9, R36, and R37 provide additional transient protection for the transceiver. J9 is a jumper that can be used to disconnect 120-Ω termination resistor R33 for use in systems that already have network termination resistors. R32 and R34 provide voltage references for the + and – connections.

5 Getting Started: Firmware

In order for the RS-485 to Wi-Fi Bridge reference design to work, CC3200MOD software must be able to control the RS-485 driver enable control line, receive data from the RS-485 transceiver and transmit that data using a socket to another end node connected in the same network. The software must also be able to receive data from the socket and write the data to the RS-485 transceiver. For this application, the serial-Wi-Fi application from CC3200 SDK was modified. Note that SDK version 1.1.0 for CC3200 silicon revision R1 was used as the code base.

5.1 Application Overview

The firmware relies heavily on the serial-Wi-Fi application, which showcases the capability of the CC3200MOD to provide easy, self-contained terminal access over a UART interface connected to an RS-485 transceiver. The application provides a driver-less solution and allows operation based on ASCII character set interpretation. Leveraging the complete network stack integration of the CC3200, it allows secure, robust end-to-end communication.

5.2 Application Features

The following features are provided in the application:

- Support to connect to an Enterprise or Personal network using OPEN, WEP, or WPA authentication
- Automatic network discovery of an available peer using mDNS
- Once a network is configured, the CC3200MOD can auto connect to the AP on every boot
- Ability to use optional secure sockets

5.3 Operating Modes

The application operates in three modes:

1. Terminal/Interpreter mode
Interpreter mode behaves as pure point-to-point cable replacement. This is the most common use in which a serial cable formerly used to carry information is replaced by SimpleLink devices on both ends of the line. This mode can also be used to extend an existing line farther without additional serial communication cable being installed.
2. Local control mode
This allows issuing commands to the locally connected device. These commands encompass a close set of options to control the SimpleLink device. The mode is entered using a predefined escape sequence (`//<`).
3. Remote control mode
This allows issuing commands to the remotely connected device. These commands encompass the same set of options to control the remote SimpleLink as the local device. The mode is entered using a predefined escape sequence (`//>`).

5.4 Application Modifications

In order for the serial-Wi-Fi application to run on the RS-485 to Wi-Fi Bridge reference design, the following sections describe the modifications required.

5.4.1 Pinmux

The following pin configurations are used in the RS-485 to Wi-Fi Bridge reference design. The files Pinmux.c and pinmux.h from the original version of Serial-Wi-Fi need to be updated to agree with [Table 3](#).

Table 3. UART Pin Assignments for the CC3200

PIN	FUNCTION	DESCRIPTION
55	UART0_TX (mode 3)	UART flashing
57	UART0_RX (mode 3)	UART flashing
58	UART1_TX (mode 6)	RS-485
59	UART1_RX (mode 6)	RS-485
60	GPIO (mode 0)	RS-485 driver enable control line

Note that the pin numbers correspond to the raw CC3200 part and not the pins assigned to these functions on the CC3200MOD.

5.4.2 Application UART Peripheral

The serial-Wi-Fi application uses UART0 peripheral by default. Since the RS-485 transceiver is connected to UART1, the application needs to be modified to use UART1. In `serial_wifi.h` and `uart_if.h`, change `CONSOLE` from `UARTA0` to `UARTA1`.

5.4.3 Secure Sockets

The serial-Wi-Fi application can be configured for secure or non-secure sockets. For non-secure sockets, comment out `#define SECURE_SOCKETS` inside `serial_wifi.h`.

5.4.4 RS-485 Driver Enable Control Line

By default, the RS-485 driver enable control line is low, which means the RS-485 receiver is enabled and the driver is disabled. To send data onto the RS-485 network, the driver needs to be enabled (by setting the driver enable control line high) prior to transmitting UART packets.

The following sequence needs to occur when a UART transmit API is called:

1. Set RS-485 driver enable control line high to enable driver:
`GPIO_IF_Set(RS485_CNTRL, ControlPort, ControlPin, 1);`
2. Transmit the UART data:
`MAP_UARTCharPut(CONSOLE, c);`
3. Wait until all UART data has been transmitted:
`while(MAP_UARTBusy(CONSOLE));`
4. Set RS-485 driver enable control line low to disable driver and enable receiver:
`GPIO_IF_Set(RS485_CNTRL, ControlPort, ControlPin, 0);`

5.4.5 Disable Receiver Echo

By default, the serial-Wi-Fi application echoes all data that is received on the UART peripheral. Due to the nature of the RS-485 bus, the echo feature is disabled in the application to eliminate the possibility of bus contention when CC3200 is echoing the received data and the host is transmitting the next data.

The echo functionality occurs in the `GETChar` function in `uart_config.c`. Remove all `MAP_UARTCharPut` API calls inside the function.

6 Getting Started

The following assumes that the user has installed the CC3200 SDK, CCS, and UniFlash to program the FLASH device on the TIDA-00485 PCB. It is recommended that the user be familiar with CC3200 Project 0 from the CC3200 wiki site. This will insure that CCS is set up correctly, the CCS UniFlash utility is installed, and the drivers (simplelink, ti_rtos_config, driverlib, oslib) have been built. The drivers must be built before the procedure in [Section 6.2](#) can be run. If application debugging capability is needed, a TI TMDSEMU100V2U-14T JTAG Emulator can be connected to J3 on the PCB.

6.1 Hardware Setup

In order to test the TIDA-00485 reference design, two systems running the modified serial-Wi-Fi application must be used. Each board must have a terminal program such as Tera Term running on a host computer. Use two host computers with the terminal program running on each if two computers are available, one for each RS-485 to Wi-Fi node. However, a single host running two terminal windows can be used.

To power the board, connect a power supply to the power connector J1. The power supply can be any AC supply between 18 V_{RMS} and 30 V_{RMS} or a DC supply between 15 and 48 V. The power supply should have at least a 1-A capacity.

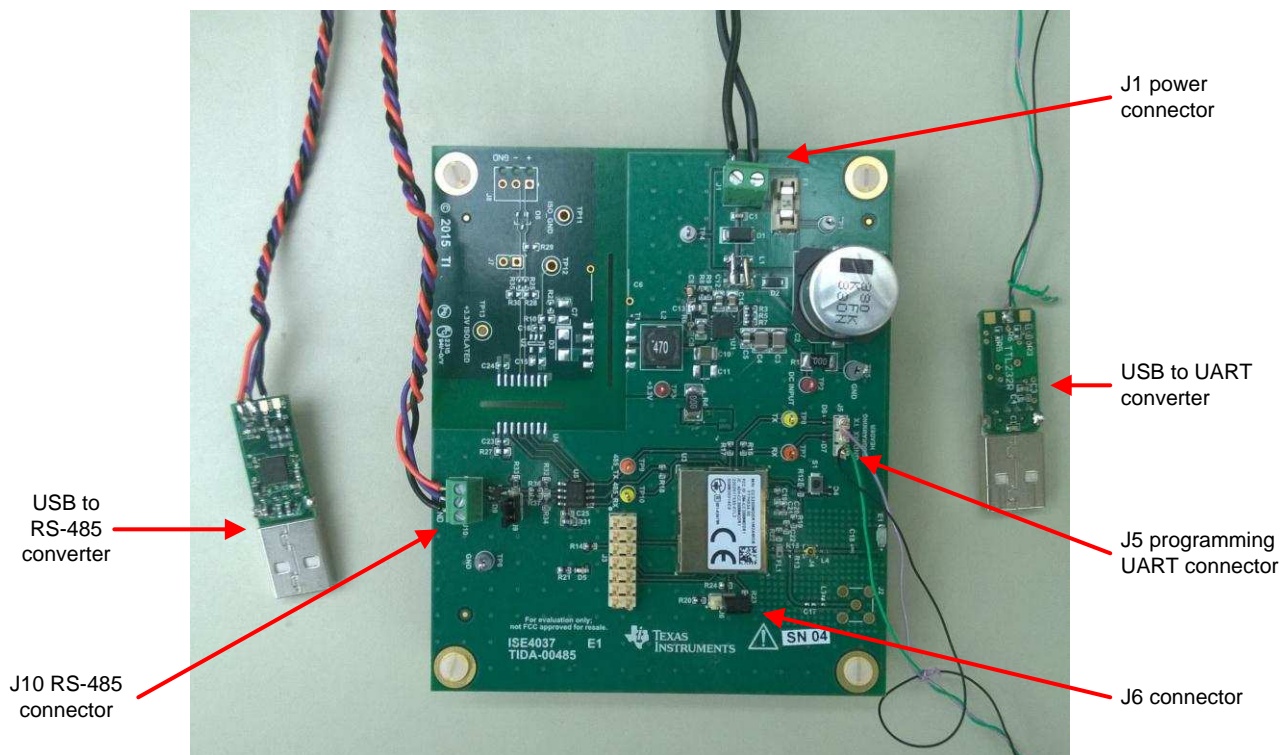

Figure 17. Power, UART, and RS-485 Connections

To monitor the RS-485 traffic, connect the J10 signals to the appropriate signals on a USB-to-RS-485 adapter. Connect the USB-to-RS-485 USB connector to the host. The dedicated UART J5 connection is the programming connection for the RS-485 to Wi-Fi Bridge PCB. Connect these signals to a USB-to-UART adapter and connect it to the host as well. Make sure that the jumper is installed on J6 before applying power to the PCB.

6.2 Software Setup

For testing purposes, the modified serial-Wi-Fi application will be used. For simplicity, the application will use non-secure sockets for the communication. The following steps describe the procedure to configure the application for non-secure sockets, build the binary, flash onto the RS-485 to Wi-Fi Bridge PCB, configure, and test.

For more information about the serial-Wi-Fi application and the use of secure sockets for communication, see the CC32xx Serial Wi-Fi documentation that is provided in the CC3200 SDK.

6.2.1 Configure the Application

1. Open CCS and import serial_wifi example application from CC3200 SDK.
2. Configure the application as described in [Section 5.4](#).
3. Build the project:
 - (a) Go to Project → Build Project.
 - (b) If using default settings, this should generate the file, serial_wifi.bin.
4. Flash binary:
 - (a) Enable programming mode (pulling SOP2 high) by placing jumper on J6.
 - (b) Connect USB-to-UART converter and adapter cable from the RS-485 to Wi-Fi Bridge PCB to host computer.
 - (c) Power on RS-485 to Wi-Fi Bridge PCB.
 - (d) Look in Device Manager and note the RS-485 to Wi-Fi Bridge PCB's COM port.
 - (e) Open CCS UniFlash program.
 - (f) Click File → New Configuration:
 - Connection: CC3x Serial (UART) Interface
 - Board or Device: SimpleLink Wi-Fi CC3100/CC3200
 - (g) Change COM Port to match the COM port found from Device Manager.
 - (h) If first time booting the hardware, perform a Service Pack Update:
 - (i) Click "Service Pack Update".
 - (ii) Find the CC3200 Service Pack binary.
 - (i) Flash the serial-Wi-Fi application:
 - (i) Click on "/sys/mcuimg.bin".
 - (ii) Change URL to point to serial_wifi.bin file generated from [Step 3: Build the project](#).
 - (iii) Make sure only the Update box is checked.
 - (iv) Go to Operation → Program.
 - (j) Power off RS-485 to Wi-Fi Bridge PCB.
 - (k) Change back to run mode (pulling SOP2 low) by removing jumper from J6.
5. Repeat [Steps 1 through 4](#) on the second RS-485 to Wi-Fi Bridge PCB.

6.2.2 Run the Application

- Open a terminal with the following settings:
 - Port: COM port from Device Manager
 - Baud Rate: 115200
 - Data: 8 bit
 - Parity: None
 - Stop: 1 bit
 - Flow control: None

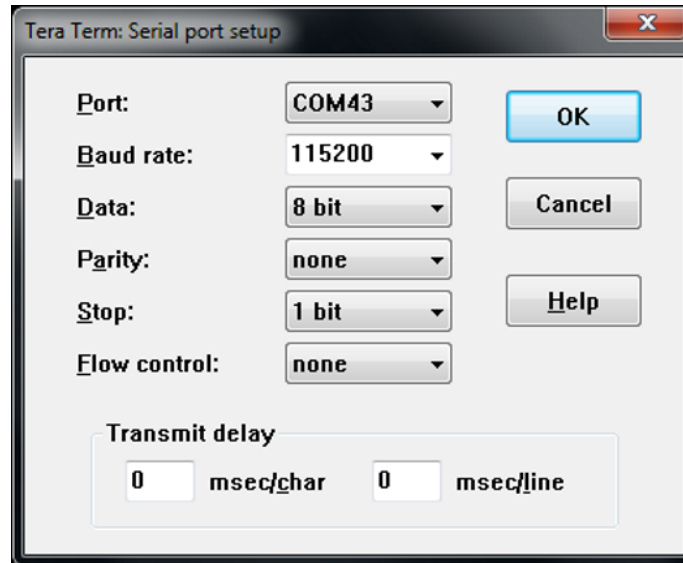

Figure 18. Tera Term Port Setup

- Enable local echo mode.
 - If using Tera Term, go to Setup → Terminal and check "Local echo".

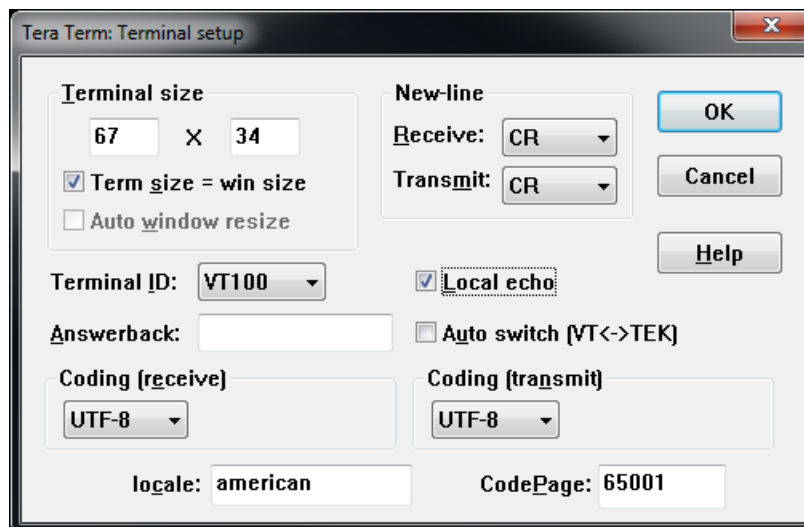

Figure 19. Setting Tera Term for Local Echo

3. Start the serial-Wi-Fi application:
 - (a) Power on the RS-485 to Wi-Fi Bridge PCB.
 - (b) The terminal should show "CC3200 SERIAL WiFi Application".
 - (c) If not, go back to [Step 4: Flash binary](#) from [Section 6.2.1](#) and try flashing the application again.
4. Connect to Access Point (AP):
 - (a) Upon reset, the device will connect to the stored AP using the AUTO connect policy. If the device connects to AP, go to [Step 5: Configure mDNS](#). If the device does not connect to an AP in six seconds, the application will prompt the user to connect to a known AP using the local control mode.

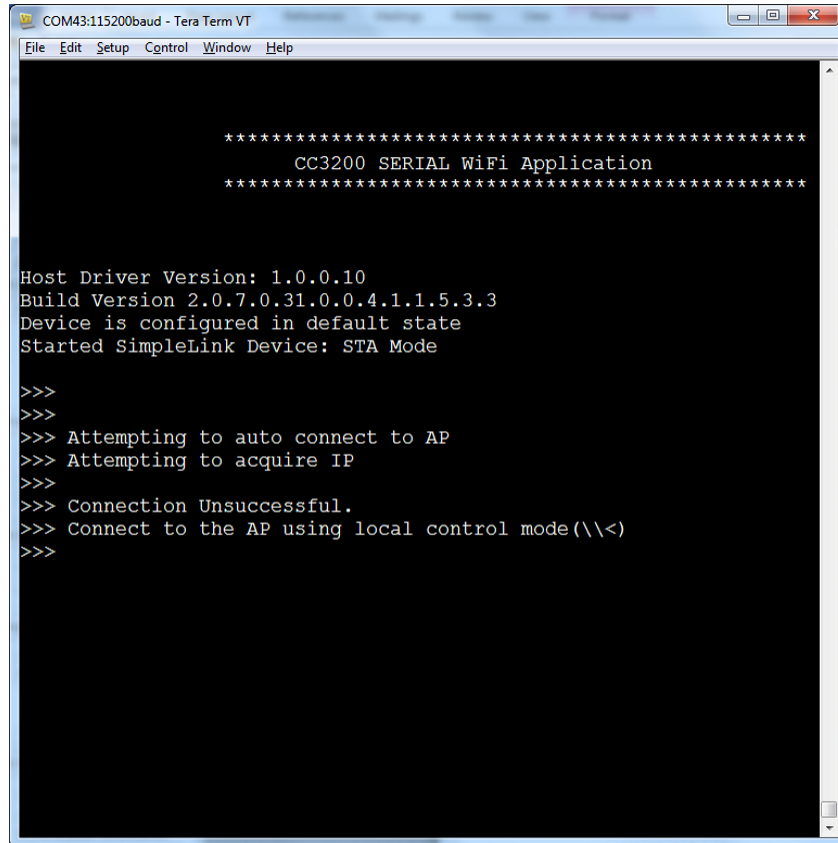
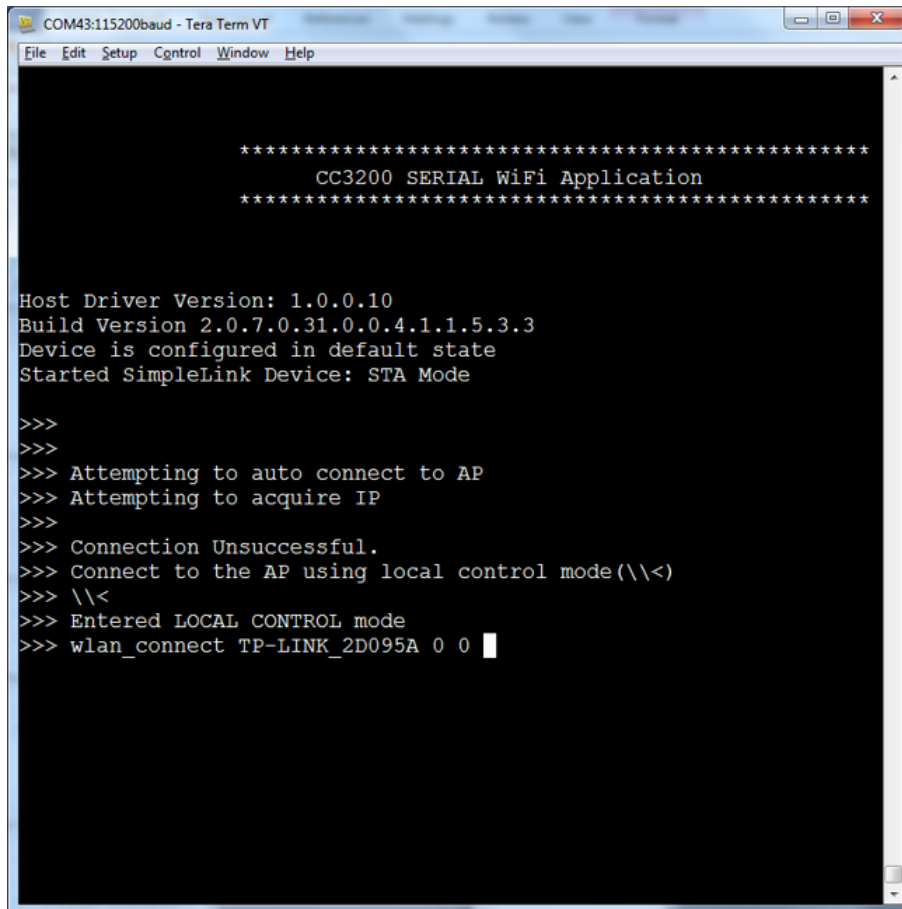

Figure 20. Terminal Information With No AP

- (b) Enter local control mode (\\<).

- (c) Use the following command to connect to an AP:
 Format: wlan_connect [SSID] [Type] [Sec] [User] [Key]
 SSID: Name of AP
 Type: 0-Personal, 1-ENT
 Sec: 0-OPEN, 1-WEP, 2-WPA
 User: Username, only needed if using ENT
 Key: Password for WEP and WPA
 Example:
 "TI_AP" SSID with no security
 wlan_connect TI_AP 0 0

"TI_AP" SSID with WPA security and password "TI_password"
 wlan_connect TI_AP 0 2 TI_password



```

COM43:115200baud - Tera Term VT
File Edit Setup Control Window Help

*****
CC3200 SERIAL WiFi Application
*****

Host Driver Version: 1.0.0.10
Build Version 2.0.7.0.31.0.0.4.1.1.5.3.3
Device is configured in default state
Started SimpleLink Device: STA Mode

>>>
>>>
>>> Attempting to auto connect to AP
>>> Attempting to acquire IP
>>>
>>> Connection Unsuccessful.
>>> Connect to the AP using local control mode(\\<)
>>> \\<
>>> Entered LOCAL CONTROL mode
>>> wlan_connect TP-LINK_2D095A 0 0
  
```

Figure 21. Setting Up the Access Point SSID

- (d) Once completed, the application will show that it was able to connect to the AP and an IP address has been acquired.

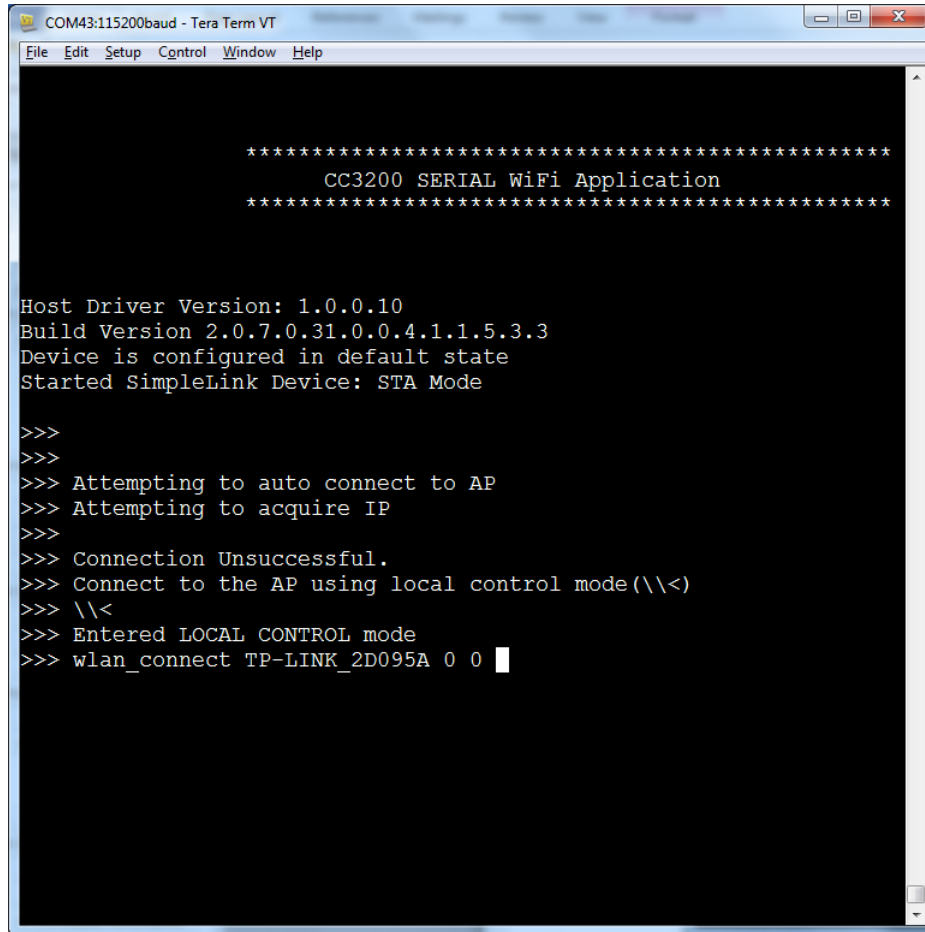

```

COM43:115200baud - Tera Term VT
File Edit Setup Control Window Help

*****
CC3200 SERIAL WiFi Application
*****

Host Driver Version: 1.0.0.10
Build Version 2.0.7.0.31.0.0.4.1.1.5.3.3
Device is configured in default state
Started SimpleLink Device: STA Mode

>>>
>>>
>>> Attempting to auto connect to AP
>>> Attempting to acquire IP
>>>
>>> Connection Unsuccessful.
>>> Connect to the AP using local control mode(\\<)
>>> \\<
>>> Entered LOCAL CONTROL mode
>>> wlan_connect TP-LINK_2D095A 0 0

```

Figure 22. Terminal Window Screenshot Showing RS-485 to Wi-Fi Bridge Console

5. Configure mDNS:
 - (a) This step only needs to be done the first time after performing a serial erase.
 - (b) One node must be configured as mDNS server. Use local control mode to program.
 - (c) Enter local control mode (\\<).
 - (d) Configure for client or server:
mDNS 0 <0-server, 1-client>

6. Repeat [Steps 1 through 5](#) for the second RS-485 to Wi-Fi Bridge.

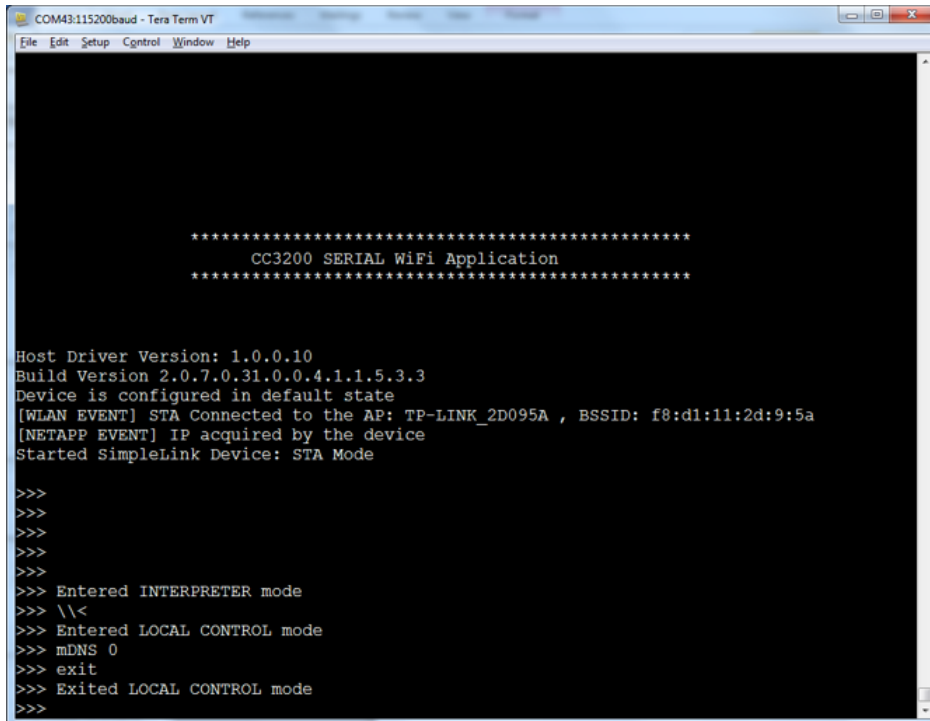

```

COM43:115200baud - Tera Term VT
File Edit Setup Control Window Help

*****
CC3200 SERIAL WiFi Application
*****

Host Driver Version: 1.0.0.10
Build Version 2.0.7.0.31.0.0.4.1.1.5.3.3
Device is configured in default state
[WLAN EVENT] STA Connected to the AP: TP-LINK_2D095A , BSSID: f8:d1:11:2d:9:5a
[NETAPP EVENT] IP acquired by the device
Started SimpleLink Device: STA Mode

>>>
>>>
>>>
>>>
>>>
>>> Entered INTERPRETER mode
>>> \\<
>>> Entered LOCAL CONTROL mode
>>> mDNS 0
>>> exit
>>> Exited LOCAL CONTROL mode
>>>

```

Figure 23. Setting DNS as Server

Devices should now be in interpreter mode. If the device is still in control mode, type "exit" to resume interpreter mode.

6.3 Communication Test

Note that the communication test can use any CC3200 hardware running the serial-Wi-Fi application. This has been tested with combinations of CC3200 LaunchPads, TIDA-0375 UART to Wi-Fi Bridge hardware, TIDA-00485 RS-485 to Wi-Fi Bridge hardware, and TIDA-00486 Isolated RS-485 to Wi-Fi Bridge hardware.

1. Power off both nodes.
2. Power on the client node first, followed by the server node. This insures that the TCP connection gets made.
3. Both nodes should connect to the same AP and acquire an IP address.
4. Verify that "TCP connection established" appears on both nodes.
5. Type on the server terminal and press <Enter> to see the same characters on the client.
6. Type on the client terminal and press <Enter> to see the same characters on the server.

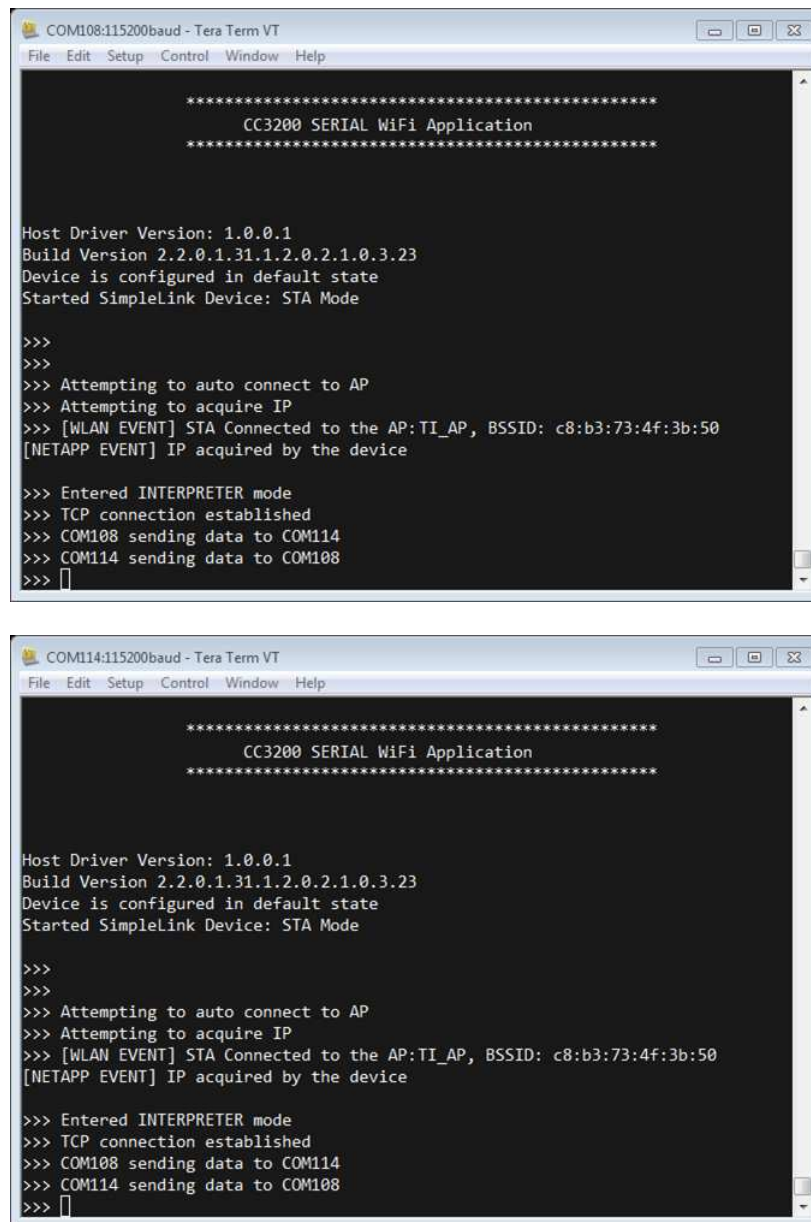

Figure 24. Terminal Window Screenshots Showing Both Consoles

7 Testing

7.1 Power Supply DC Testing

In order to test the power supply efficiency, DC input voltage was used to simplify testing. The test equipment used includes Agilent 34401A and 34410A DMMs and a Chroma model 62006P-100-25 Programmable DC Power Supply. Input current was measured through the power leads connected to J1. Input voltage was measured at TP2. Output voltage was measured at TP3. The output current was measured by removing R4 and connecting a DMM set to measure current in R4's place. The RS-485 data was monitored using a Tera Term terminal for each board. All tests were performed at 23°C.

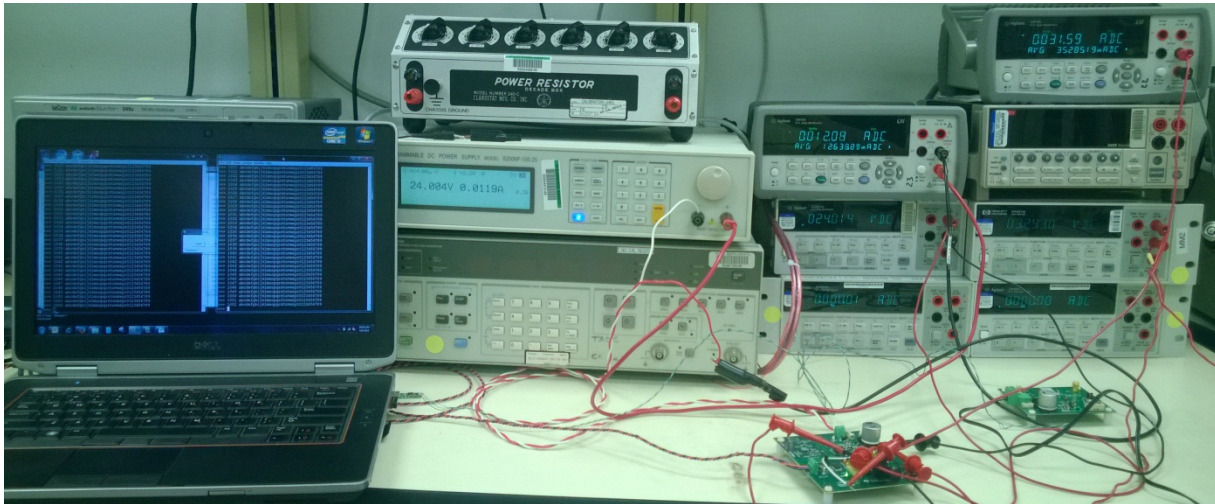

Figure 25. Efficiency Test Setup

Two boards were set up with the RS-485 serial-Wi-Fi software, one as DNS master, and one as DNS slave. Power was measured when there was no RS-485 data being sent and when there was continuous RS-485 data sent into the unit under test. With no data, the power consumption is lowest because the Wi-Fi transmissions are just beacons to maintain the connection to the AP and no data packets are sent. With continuous RS-485 data, data packets are constantly being sent with a baud rate of 115.2 kbaud, and the average current used by the system increases compared to the no data case. No other cases were measured since the results will fall between these two extremes.

Power was measured at different voltages from 12-V to 48-V DC. Data for these two data transmission cases are show in [Table 4](#) and [Table 5](#).

Table 4. Power Supply Efficiency for Idle Communications

INPUT VOLTAGE (V)	INPUT CURRENT (mA)	INPUT POWER (mW)	OUTPUT VOLTAGE (V)	OUTPUT CURRENT (mA)	OUTPUT POWER (mW)	EFFICIENCY
12.01	16.4	196.964	3.292	34.7	114.2324	58.00%
15.03	14.8	222.444	3.292	34.2	112.5864	50.61%
18.09	13.7	247.833	3.292	34.2	112.5864	45.43%
21.10	13.0	273.878	3.293	34.4	113.2792	41.36%
24.01	12.7	304.927	3.293	34.1	112.2913	36.83%
24.04	12.4	298.274	3.293	34.1	112.2913	37.65%
27.08	12.0	324.960	3.293	34.2	112.6206	34.66%
30.03	11.8	354.354	3.293	34.4	113.2792	31.97%
35.03	11.6	406.348	3.294	34.7	114.3018	28.13%
40.03	11.4	456.342	3.294	34.1	112.3254	24.61%
45.03	11.4	513.342	3.294	34.5	113.6430	22.14%
48.09	11.4	548.226	3.295	34.7	114.3365	20.86%

Table 5. Power Supply Efficiency for Continuous Communications

INPUT VOLTAGE (V)	INPUT CURRENT (mA)	INPUT POWER (mW)	OUTPUT VOLTAGE (V)	OUTPUT CURRENT (mA)	OUTPUT POWER (mW)	EFFICIENCY
12.10	24.0	290.400	3.292	60.1	197.8492	68.13%
15.00	20.9	313.500	3.292	61.3	201.7996	64.37%
18.06	18.3	330.498	3.293	58.6	192.9698	58.39%
21.04	16.1	338.744	3.293	53.2	175.1876	51.72%
24.03	15.8	379.721	3.293	57.7	190.0061	50.04%
27.04	15.2	411.008	3.293	58.1	191.3233	46.55%
27.06	15.0	405.900	3.293	57.9	190.6647	46.97%
30.05	14.5	435.725	3.294	57.6	189.7344	43.54%
35.04	14.1	494.064	3.294	59.7	196.6518	39.80%
40.05	13.6	544.680	3.294	59.1	194.6754	35.74%
45.04	13.4	603.536	3.294	59.2	195.0048	32.31%
48.05	13.4	643.870	3.295	60.2	198.3590	30.81%

Comparing the efficiencies calculated in Table 4 and Table 5 shows that the power supply efficiency is 10% higher for the high power continuously transmitting case. The average load current, and therefore the average power, is very low, even though the load current can be quite high during data transmissions. Figure 26 shows an oscilloscope trace of the load current and the 3.3-V supply output ripple over a period of several seconds.

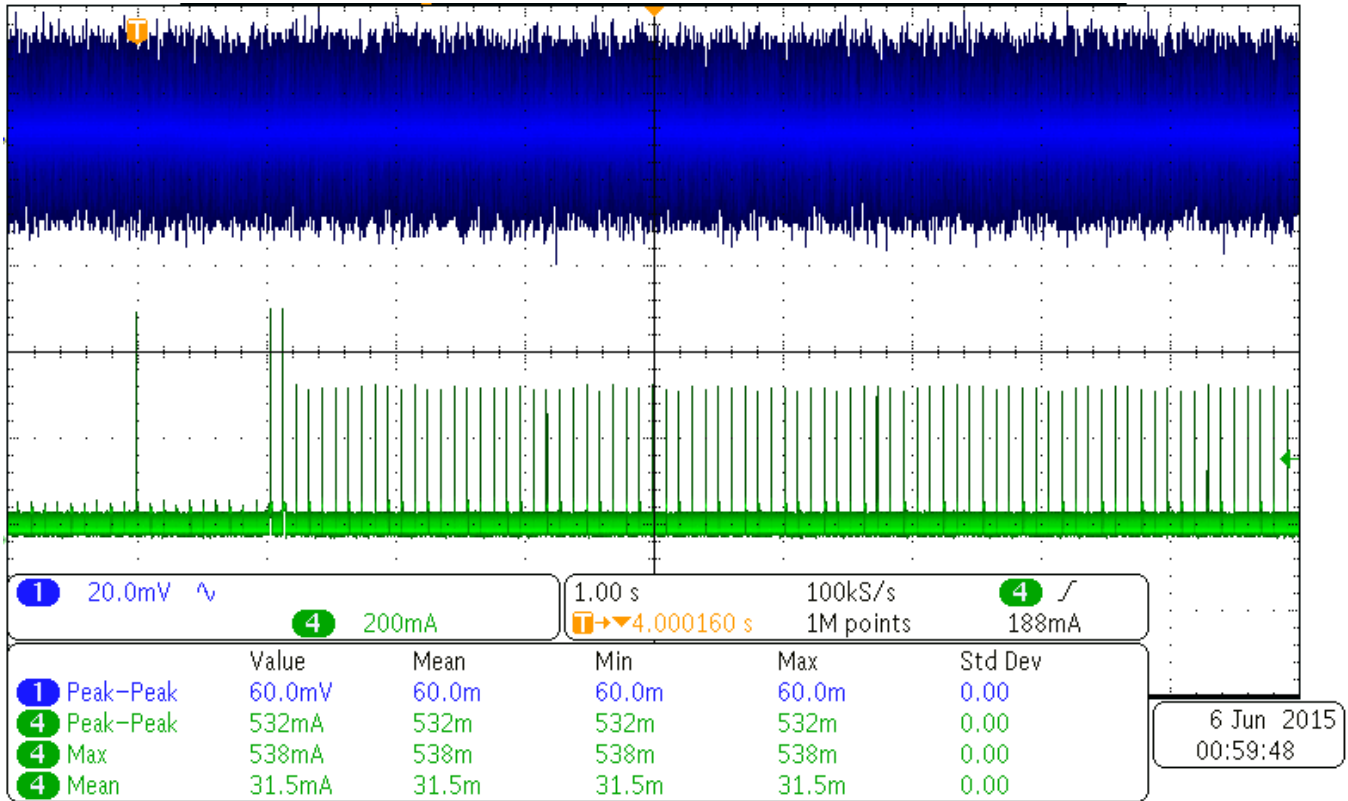

Figure 26. Load Current, No Data Transmission (Green); 3.3-V Supply Ripple (Blue)

The oscilloscope trace shows many short, high current pulses. The peak load current is 538 mA, while the average current is only 31.5 mA. The 3.3-V supply has voltage ripple of 60 mV peak-to-peak. Figure 27 shows a closer measurement of one of the load current peaks.

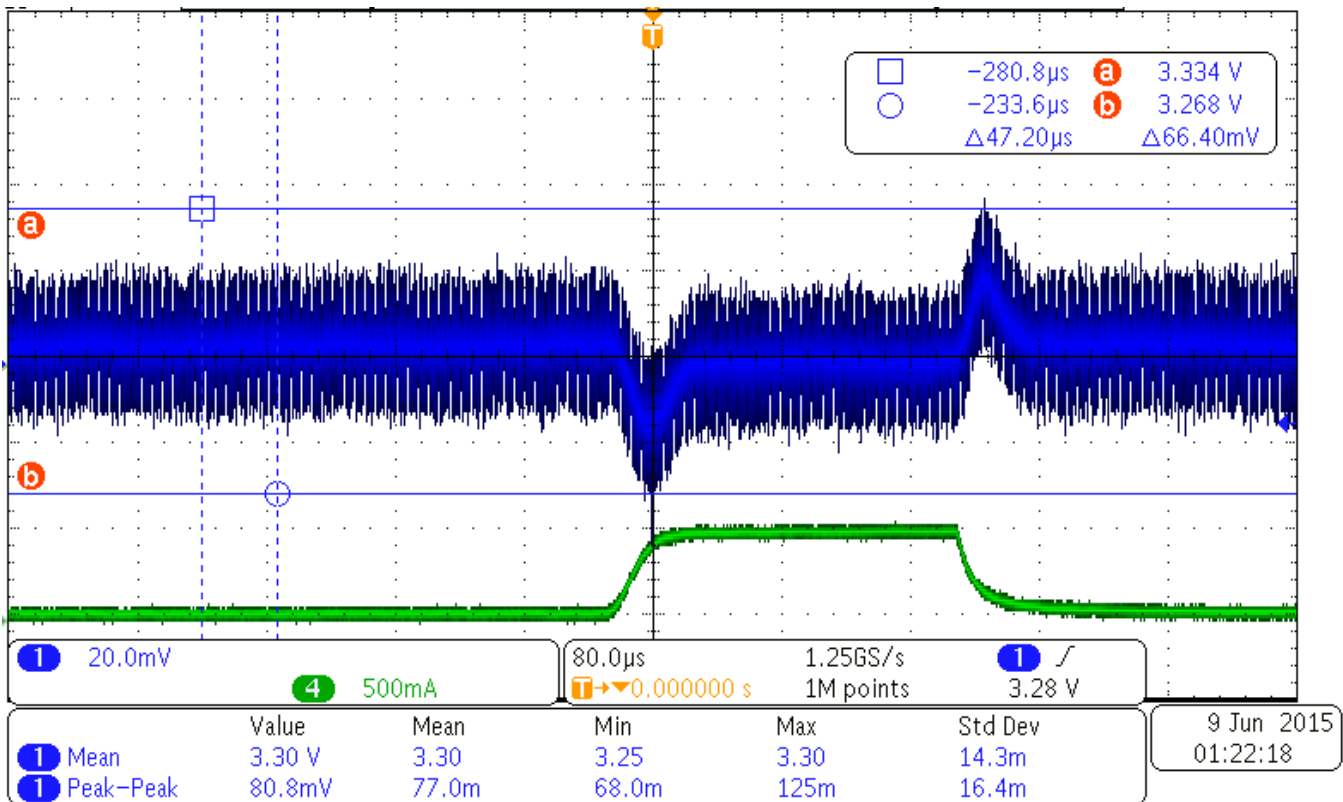

Figure 27. Load Current Peak (Green); 3.3-V Ripple (Blue)

The blue trace in Figure 27 shows the 3.3-V power supply output response to a load current change of 460 mA. This trace simulates a load change in the system by using an active load.

The SN65HVD72 transceiver drew 525 μ A when the RS-485 connection was idle and 685 μ A when the RS-485 connection was running at 115.2 kbaud.

The power supply efficiency measured above is lower than expected. This is because the average current used by the system is low even when transmitting. However, the current rating of the power supply must be high enough to supply the peak current required by the system.

7.2 Power Supply AC Testing

The RS-485 to Wi-Fi Bridge was tested with a Kikusui PCR500M AC Power Supply. The minimum AC voltage that the system worked at was 7.7-V AC, 60 Hz. The rectified and filtered input voltage at TP2 was 9.89 V with the 7.7-V AC input. Lowering the voltage to 7.7-V AC leads to the processor resetting. The system would not start up again unless the input voltage was 8.3-V AC.

The voltage on the filter capacitor C2 was measured with an oscilloscope to compare the results to the ripple voltage expected from Section 4.1. The assumption when choosing C2 was that the load would be drawing its maximum current for an entire 60-Hz cycle. Figure 26 in Section 7.1 shows that the high current condition in the load occurs for short periods and is not continuous. Because of this, the voltage ripple at C2 is much lower than calculated. The ripple voltage for an input voltage of 18-V AC on C2 is shown in Figure 28.

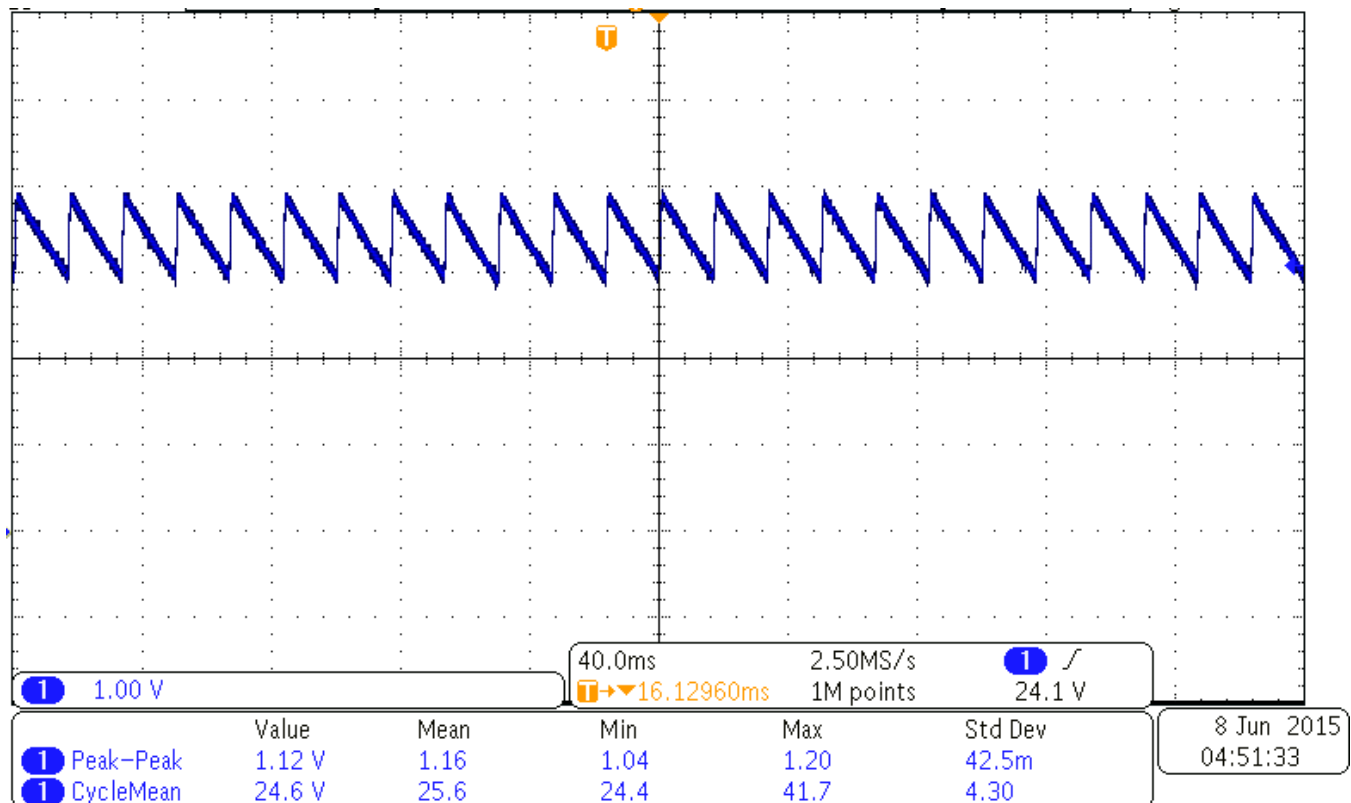

Figure 28. Ripple Voltage at C2 for an 18-V AC, 60-Hz Input

For the measurement in Figure 28, the system was transmitting constantly as it was for the efficiency measurement, ensuring a maximum ripple. The peak-to-peak voltage ripple is only 1.12 V in this case, much less than the expected 8 V.

For a 50-Hz input, the voltage ripple on C2 is higher (see Figure 29).

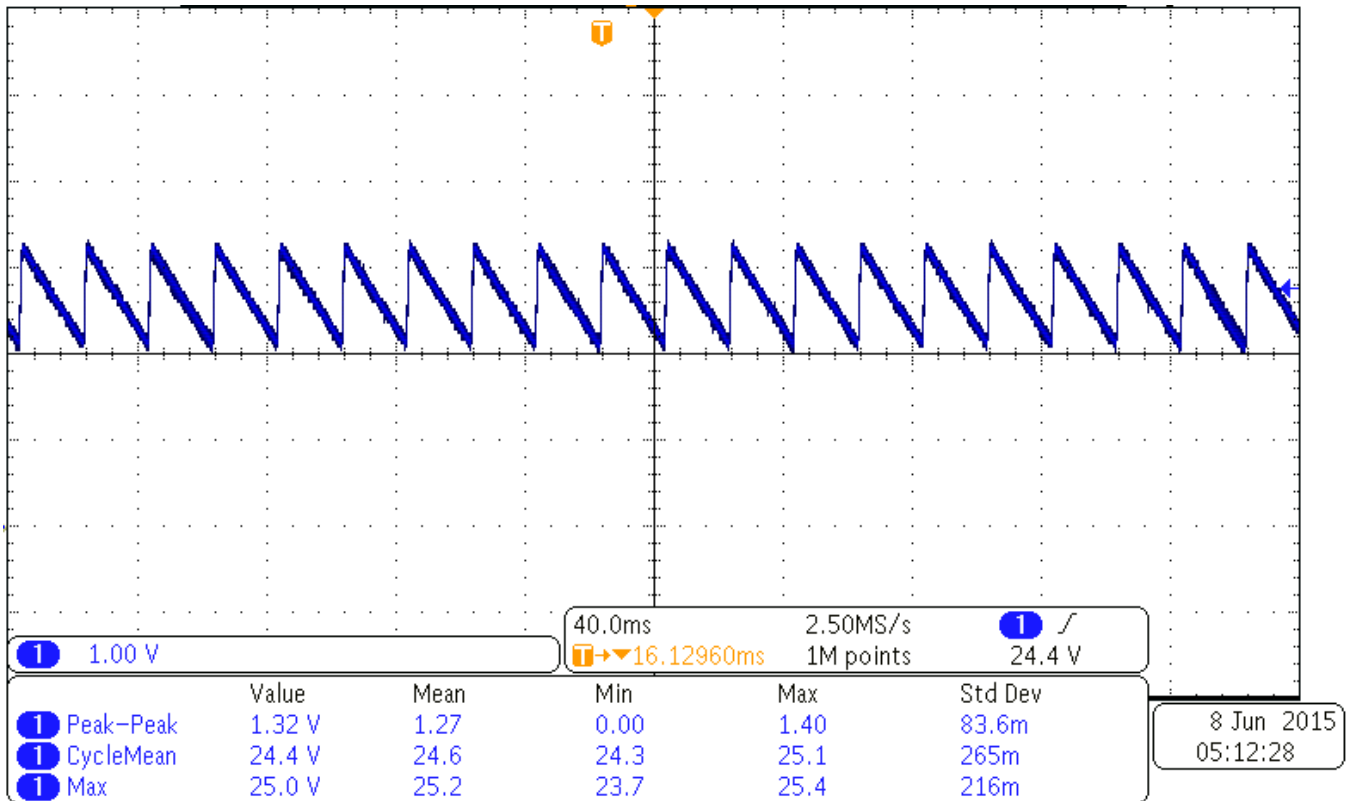

Figure 29. Ripple Voltage at C2 for an 18-V AC, 50-Hz Input

The ripple is higher in this case, 1.32 V peak-to-peak due to the lower input voltage frequency.

7.3 CC3200 Performance

7.3.1 Data Throughput

The data in this section was provided by the CC3100 and CC3200 design team. It is included here to show the Wi-Fi data throughput performance.

The following two graphs show data throughput measurements with the hardware set up as both an AP and a Station. The data was not taken on the hardware described in this document. It was taken with a CC3100-based system that includes the CC3100 BoosterPack. The CC3100 and CC3200 have the same network processor subsystems, so their performance will be the same. The antenna on the PCB for the RS-485 to Wi-Fi Bridge is the same antenna used in the CC3100 BoosterPack, and great care has been taken to ensure the RS-485 to Wi-Fi Bridge RF output circuit matches the CC3100 BoosterPack, including the trace width, the thickness of the PCB dielectric between the RF output traces and the ground plane, and the overall board thickness.

The CC3100 system was tested in a chamber using a Cisco AP 1252 router and a Cisco-Linksys AE1000 router. The test measures throughput versus path loss (range) where the AP or Station is placed in a chamber. Range is simulated by using an attenuator to reduce the module output power.

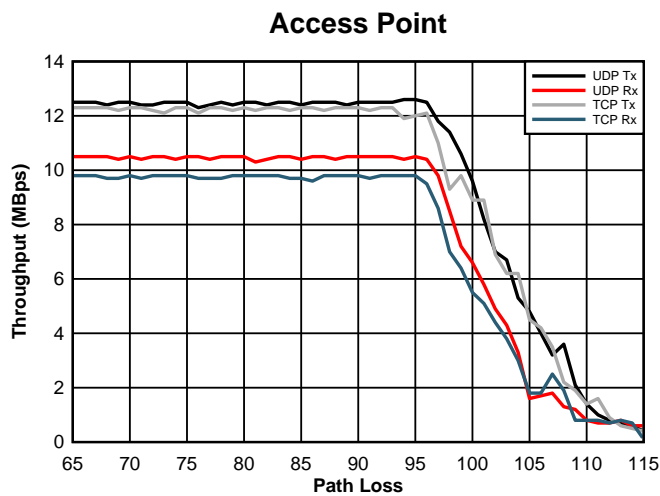

Figure 30. Data Throughput versus Path Loss, CC3100 Access Point

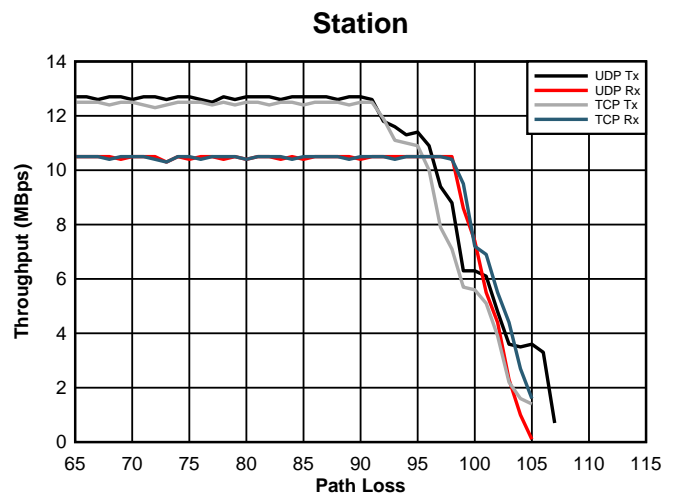

Figure 31. Data Throughput versus Path Loss, CC3100 Station

The RS-485 to Wi-Fi Bridge is limited in its throughput by the CC3200 UART module. The UART module has a maximum bit rate of 3 Mbits per second.

7.3.2 In-Office Range Test

For these tests, the RS-485 in the RS-485 to Wi-Fi Bridge was tested at 115.2 kbits per second.

In order to see how the RS-485 to Wi-Fi Bridge can perform in an office environment, tests were run with the hardware set up as described in [Section 6.2](#). Using a TP-Link model TL-WR740N router at the AP, one of the systems was moved away from the router and communication was re-checked. In one test, communication was still possible with one system at a distance of 83.3 meters from the AP. There were no obstructions between the system and the AP, though the RF line-of-sight was down a narrow corridor with walls and cubicles lining the corridor. Another test had the system 25.4 meters from the AP, but the RF signal had to penetrate four walls and several rows of cubicles to get from the AP to the system.

This test is not meant to be a definitive performance test. Actual user performance depends upon many factors, such as the model of the AP used, the amount of RF interference in the environment in which the hardware is installed, the location of the hardware in relation to walls or metal objects, and other factors unique to each installation.

8 Other Applications

The software used to test the RS-485 to Wi-Fi Bridge with 24-V AC Power acts as a cable bridge between two disconnected sections of a network. The RS-485 to Wi-Fi Bridge was also tested with a UART to Wi-Fi Bridge that was designed for TI Design TIDA-00375, and they interoperate seamlessly.

There are many other uses for this hardware that were not developed for this project. This hardware can be used as an AP and could serve a web page with information about the RS-485 network. This could be accessed by a technician using a smart phone, a tablet, or a laptop computer. Another use is to have the hardware setup as a station connected to an external AP that is connected to the internet. In this way, the RS-485 to Wi-Fi Bridge would provide data to a cloud server that can be remotely accessed or used for data analysis.

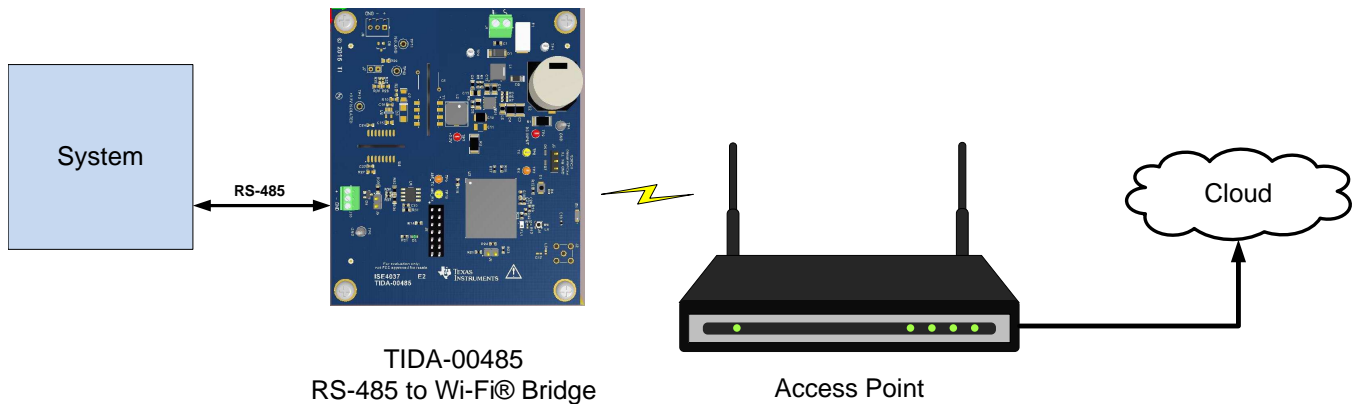

Figure 32. RS-485 to Cloud System

9 Design Files

9.1 Schematics

To download the schematics, see the design files at TIDA-00485.

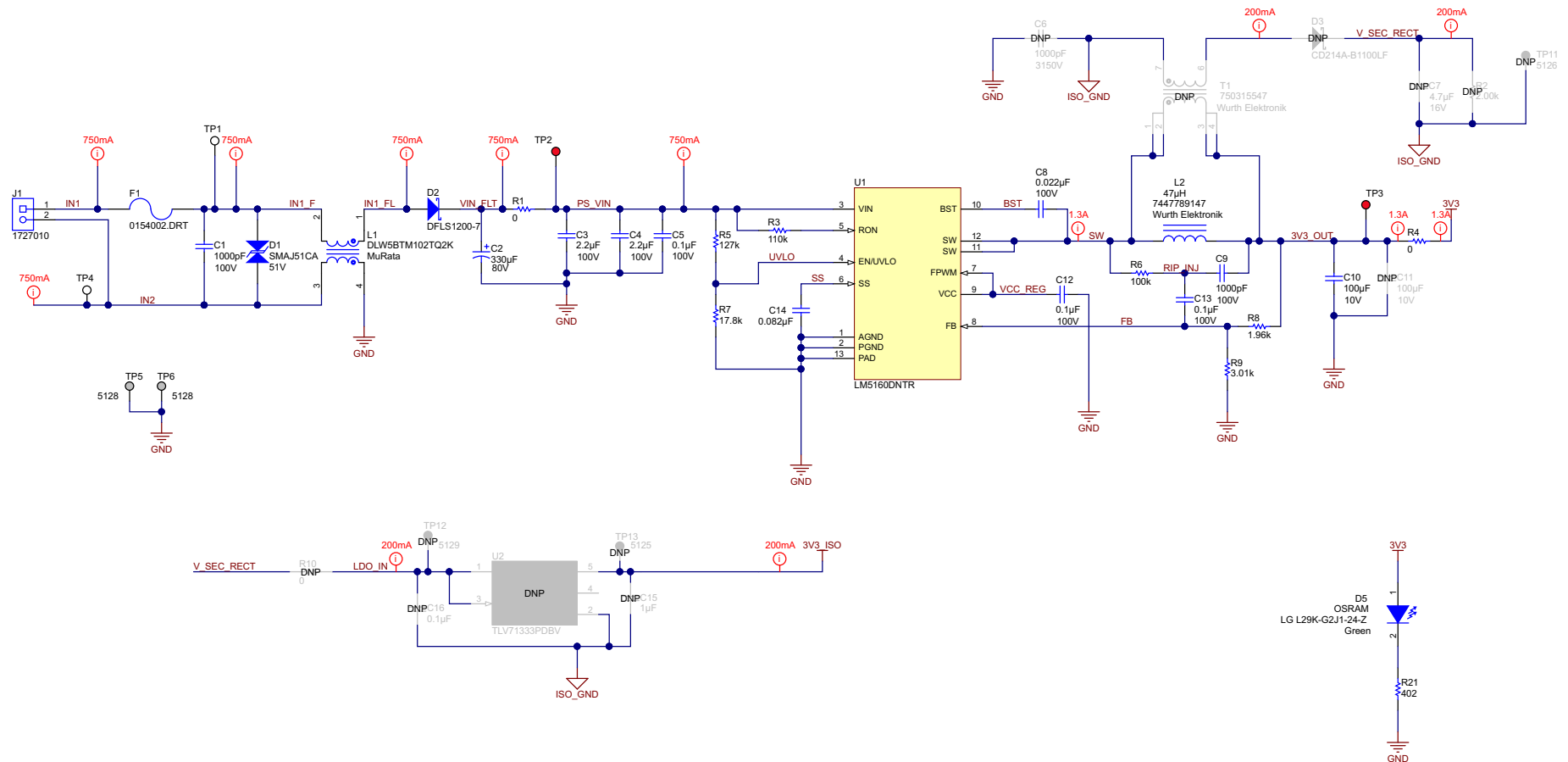

Figure 33. Power Supply Schematic

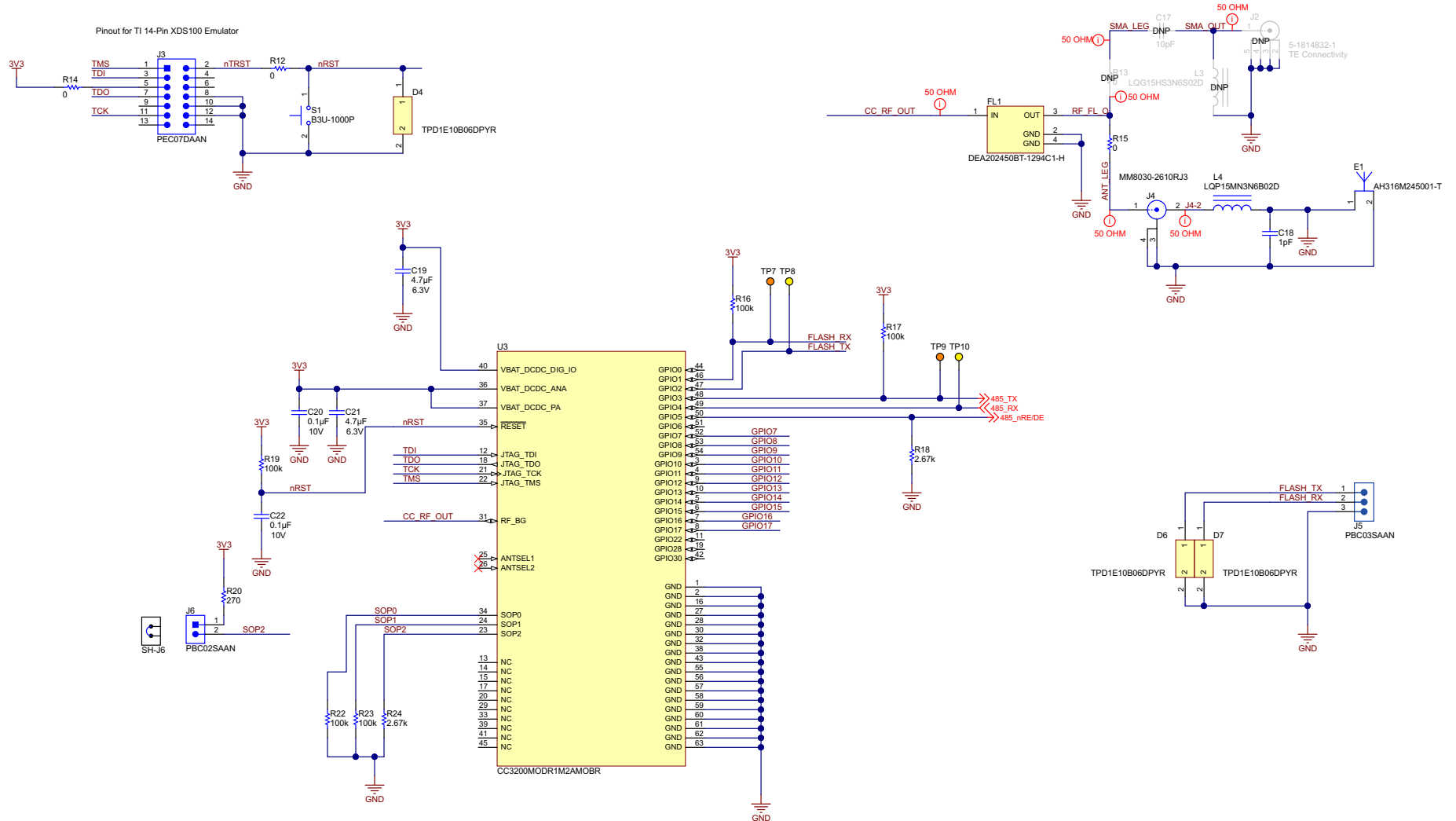
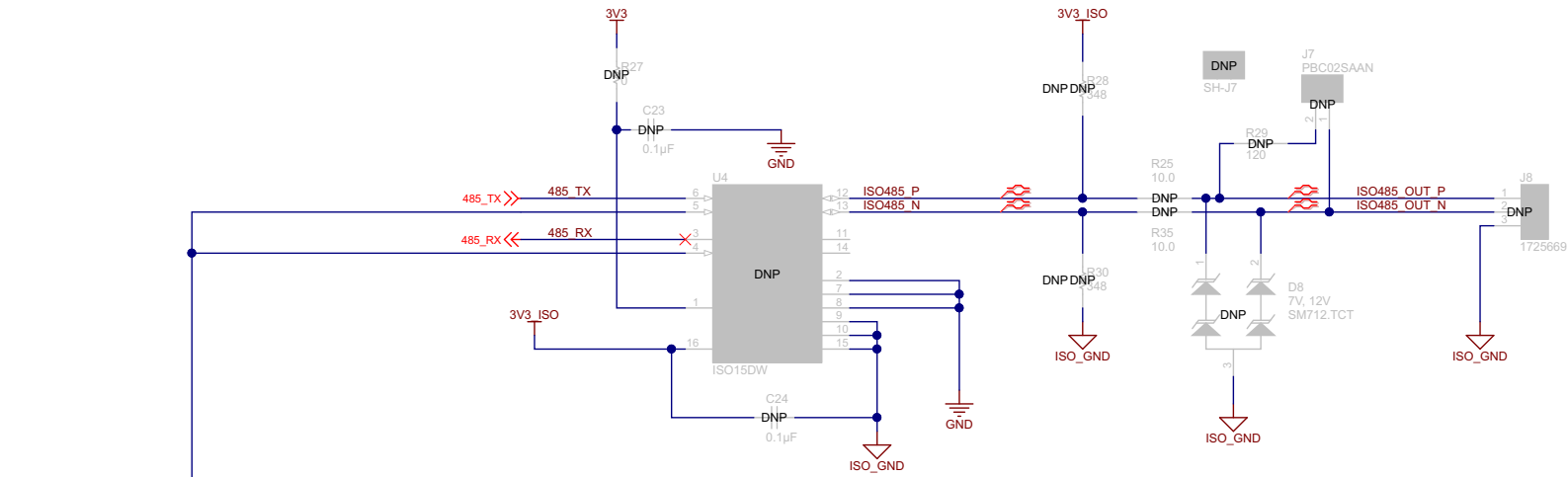

Figure 34. CC3200MOD Schematic

ISOLATED TRANSCIEVER



NON-ISOLATED TRANSCIEVER

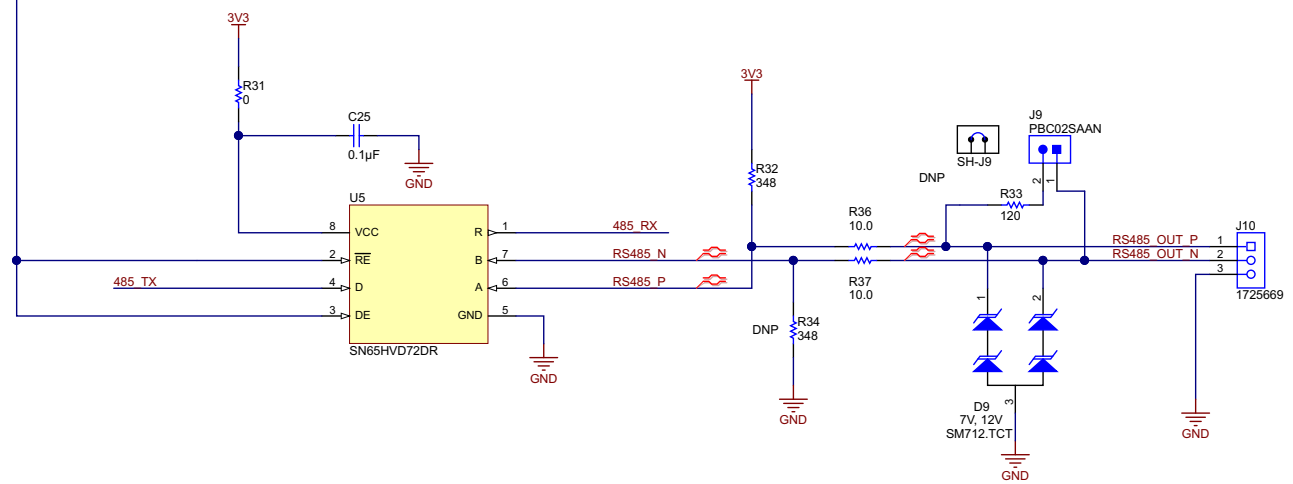

Figure 35. Interface Schematic

9.2 **Bill of Materials**

To download the bill of materials (BOM), see the design files at [TIDA-00485](#).

9.3 **PCB Layout Recommendations**

The layout of this PCB was done by carefully following the recommended guidelines for the LM5160, the CC3200MOD, and for the Taiyo Yuden AH316M245001-T chip antenna. The power nets from J1 through to the 3V3 net are made as wide as practical. For the CC3200MOD, follow the *Hardware Design Review Process and PCB Layout Design Guidelines* found on the [SimpleLink Wi-Fi CC31xx/CC32xx Main Page](#) for best results.

9.3.1 **Layer Plots**

To download the layer plots, see the design files at [TIDA-00485](#).

9.4 **Altium Project**

To download the Altium project files, see the design files at [TIDA-00485](#).

9.5 **Gerber Files**

To download the Gerber files, see the design files at [TIDA-00485](#).

9.6 **Assembly Drawings**

To download the assembly drawings, see the design files at [TIDA-00485](#).

10 Software Files

To download the software files, see the design files at [TIDA-00485](#).

11 References

1. Texas Instruments, *CC3200MOD SimpleLink™ Wi-Fi® and Internet-of-Things Module Solution, a Single-Chip Wireless MCU*, CC3200MOD Datasheet ([SWRS166](#))
2. Texas Instruments, *SimpleLink™ Wi-Fi® CC31xx/CC32xx Main Page* ([link](#))
3. Texas Instruments, *SimpleLink Wi-Fi CC3100 BoosterPack* (<http://www.ti.com/tool/cc3100boost>)
4. Texas Instruments, *Wide Input 65-V, 1.5-A Synchronous Buck / Fly-Buck™ Converter*, LM5160 Datasheet ([SNVSA03](#))
5. Texas Instruments, *LM5160 Buck Regulator Quick Start Calculator* (<http://www.ti.com/tool/lm5160dntbk-calc>)
6. Texas Instruments, *3.3V-Supply RS-485 with IEC ESD Protection*, SN65HVD72 Datasheet([SLLSE11](#))
7. Texas Instruments, *TPD1E10B06 Single Channel ESD in 0402 Package*, TPD1E10B06 Datasheet ([SLLSEB1](#))

12 Terminology

AP— Access Point. This is the radio to which Wi-Fi devices attach. This can be a router or a CC3200.

DMM— Digital Multimeter

13 Acknowledgments

The authors would like to thank Ben Gilboa, Moshe Leibo, and all of the members of the CC3100/CC3200 SimpleLink team for their support for this project and especially for the throughput data.

14 About the Authors

MARK KNAPP is a Systems Architect at Texas Instruments where he is responsible for developing reference design solutions for the Building Automation segment. He has an extensive background in video camera systems and infrared imaging systems for Military, Automotive, and Industrial applications. Mark earned his BSEE at the University of Michigan-Dearborn and his MSEE at the University of Texas at Dallas.

CHRISTINA S. LAM is a Systems Architect at Texas Instruments where she is responsible for developing firmware for reference design solutions in the industrial segment. Christina has broad experience with applications processors, microcontrollers, and digital-signal processors with specialties in embedded firmware. Christina earned her BS in electrical and computer engineering from the University of Texas at Austin.

Revision B History

Changes from A Revision (July 2015) to B Revision	Page
--	-------------

- Changed from USB-to-RS-485 to USB-to-UART 19
-

NOTE: Page numbers for previous revisions may differ from page numbers in the current version.

Revision A History

Changes from Original (June 2015) to A Revision	Page
--	-------------

- Changed from preview page..... 1
-

NOTE: Page numbers for previous revisions may differ from page numbers in the current version.

IMPORTANT NOTICE FOR TI REFERENCE DESIGNS

Texas Instruments Incorporated ("TI") reference designs are solely intended to assist designers ("Buyers") who are developing systems that incorporate TI semiconductor products (also referred to herein as "components"). Buyer understands and agrees that Buyer remains responsible for using its independent analysis, evaluation and judgment in designing Buyer's systems and products.

TI reference designs have been created using standard laboratory conditions and engineering practices. **TI has not conducted any testing other than that specifically described in the published documentation for a particular reference design.** TI may make corrections, enhancements, improvements and other changes to its reference designs.

Buyers are authorized to use TI reference designs with the TI component(s) identified in each particular reference design and to modify the reference design in the development of their end products. HOWEVER, NO OTHER LICENSE, EXPRESS OR IMPLIED, BY ESTOPPEL OR OTHERWISE TO ANY OTHER TI INTELLECTUAL PROPERTY RIGHT, AND NO LICENSE TO ANY THIRD PARTY TECHNOLOGY OR INTELLECTUAL PROPERTY RIGHT, IS GRANTED HEREIN, including but not limited to any patent right, copyright, mask work right, or other intellectual property right relating to any combination, machine, or process in which TI components or services are used. Information published by TI regarding third-party products or services does not constitute a license to use such products or services, or a warranty or endorsement thereof. Use of such information may require a license from a third party under the patents or other intellectual property of the third party, or a license from TI under the patents or other intellectual property of TI.

TI REFERENCE DESIGNS ARE PROVIDED "AS IS". TI MAKES NO WARRANTIES OR REPRESENTATIONS WITH REGARD TO THE REFERENCE DESIGNS OR USE OF THE REFERENCE DESIGNS, EXPRESS, IMPLIED OR STATUTORY, INCLUDING ACCURACY OR COMPLETENESS. TI DISCLAIMS ANY WARRANTY OF TITLE AND ANY IMPLIED WARRANTIES OF MERCHANTABILITY, FITNESS FOR A PARTICULAR PURPOSE, QUIET ENJOYMENT, QUIET POSSESSION, AND NON-INFRINGEMENT OF ANY THIRD PARTY INTELLECTUAL PROPERTY RIGHTS WITH REGARD TO TI REFERENCE DESIGNS OR USE THEREOF. TI SHALL NOT BE LIABLE FOR AND SHALL NOT DEFEND OR INDEMNIFY BUYERS AGAINST ANY THIRD PARTY INFRINGEMENT CLAIM THAT RELATES TO OR IS BASED ON A COMBINATION OF COMPONENTS PROVIDED IN A TI REFERENCE DESIGN. IN NO EVENT SHALL TI BE LIABLE FOR ANY ACTUAL, SPECIAL, INCIDENTAL, CONSEQUENTIAL OR INDIRECT DAMAGES, HOWEVER CAUSED, ON ANY THEORY OF LIABILITY AND WHETHER OR NOT TI HAS BEEN ADVISED OF THE POSSIBILITY OF SUCH DAMAGES, ARISING IN ANY WAY OUT OF TI REFERENCE DESIGNS OR BUYER'S USE OF TI REFERENCE DESIGNS.

TI reserves the right to make corrections, enhancements, improvements and other changes to its semiconductor products and services per JESD46, latest issue, and to discontinue any product or service per JESD48, latest issue. Buyers should obtain the latest relevant information before placing orders and should verify that such information is current and complete. All semiconductor products are sold subject to TI's terms and conditions of sale supplied at the time of order acknowledgment.

TI warrants performance of its components to the specifications applicable at the time of sale, in accordance with the warranty in TI's terms and conditions of sale of semiconductor products. Testing and other quality control techniques for TI components are used to the extent TI deems necessary to support this warranty. Except where mandated by applicable law, testing of all parameters of each component is not necessarily performed.

TI assumes no liability for applications assistance or the design of Buyers' products. Buyers are responsible for their products and applications using TI components. To minimize the risks associated with Buyers' products and applications, Buyers should provide adequate design and operating safeguards.

Reproduction of significant portions of TI information in TI data books, data sheets or reference designs is permissible only if reproduction is without alteration and is accompanied by all associated warranties, conditions, limitations, and notices. TI is not responsible or liable for such altered documentation. Information of third parties may be subject to additional restrictions.

Buyer acknowledges and agrees that it is solely responsible for compliance with all legal, regulatory and safety-related requirements concerning its products, and any use of TI components in its applications, notwithstanding any applications-related information or support that may be provided by TI. Buyer represents and agrees that it has all the necessary expertise to create and implement safeguards that anticipate dangerous failures, monitor failures and their consequences, lessen the likelihood of dangerous failures and take appropriate remedial actions. Buyer will fully indemnify TI and its representatives against any damages arising out of the use of any TI components in Buyer's safety-critical applications.

In some cases, TI components may be promoted specifically to facilitate safety-related applications. With such components, TI's goal is to help enable customers to design and create their own end-product solutions that meet applicable functional safety standards and requirements. Nonetheless, such components are subject to these terms.

No TI components are authorized for use in FDA Class III (or similar life-critical medical equipment) unless authorized officers of the parties have executed an agreement specifically governing such use.

Only those TI components that TI has specifically designated as military grade or "enhanced plastic" are designed and intended for use in military/aerospace applications or environments. Buyer acknowledges and agrees that any military or aerospace use of TI components that have **not** been so designated is solely at Buyer's risk, and Buyer is solely responsible for compliance with all legal and regulatory requirements in connection with such use.

TI has specifically designated certain components as meeting ISO/TS16949 requirements, mainly for automotive use. In any case of use of non-designated products, TI will not be responsible for any failure to meet ISO/TS16949.