

TAPE AND REEL INFORMATION

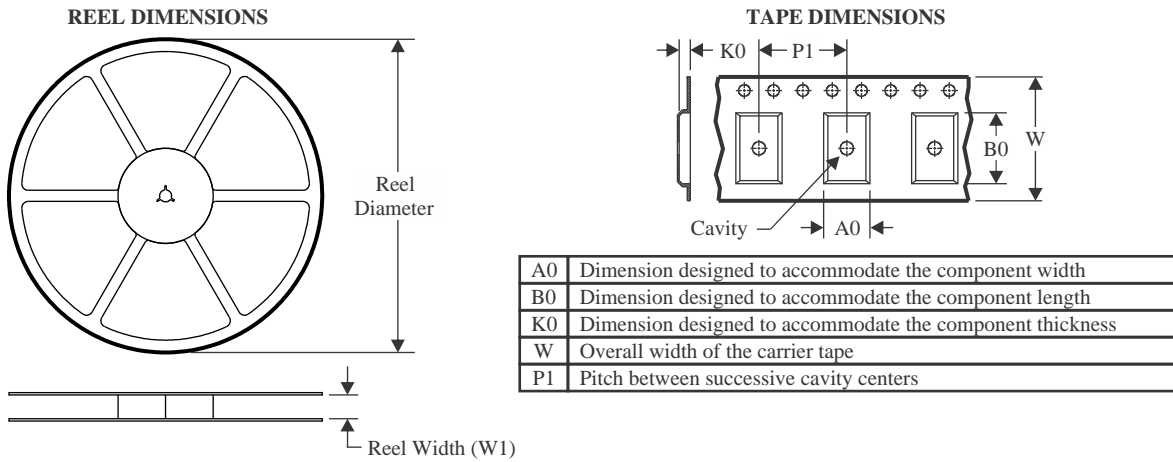

QUADRANT ASSIGNMENTS FOR PIN 1 ORIENTATION IN TAPE

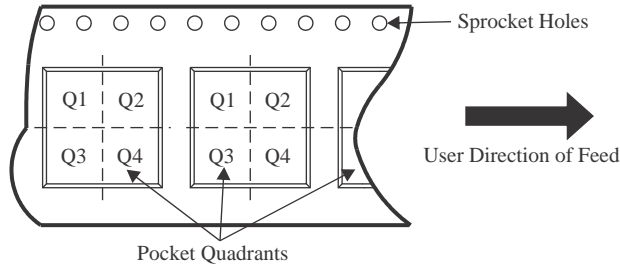

*All dimensions are nominal

Device	Package Type	Package Drawing	Pins	SPQ	Reel Diameter (mm)	Reel Width W1 (mm)	A0 (mm)	B0 (mm)	K0 (mm)	P1 (mm)	W (mm)	Pin1 Quadrant
TMCS1126A1AQDVGR	SOIC	DVG	10	2000	330.0	16.4	10.75	10.7	2.7	12.0	16.0	Q1
TMCS1126A1BQDVGR	SOIC	DVG	10	2000	330.0	16.4	10.75	10.7	2.7	12.0	16.0	Q1
TMCS1126A2AQDVGR	SOIC	DVG	10	2000	330.0	16.4	10.75	10.7	2.7	12.0	16.0	Q1
TMCS1126A2BQDVGR	SOIC	DVG	10	2000	330.0	16.4	10.75	10.7	2.7	12.0	16.0	Q1
TMCS1126A3AQDVGR	SOIC	DVG	10	2000	330.0	16.4	10.75	10.7	2.7	12.0	16.0	Q1
TMCS1126A3BQDVGR	SOIC	DVG	10	2000	330.0	16.4	10.75	10.7	2.7	12.0	16.0	Q1
TMCS1126A4AQDVGR	SOIC	DVG	10	2000	330.0	16.4	10.75	10.7	2.7	12.0	16.0	Q1
TMCS1126A4BQDVGR	SOIC	DVG	10	2000	330.0	16.4	10.75	10.7	2.7	12.0	16.0	Q1
TMCS1126A5AQDVGR	SOIC	DVG	10	2000	330.0	16.4	10.75	10.7	2.7	12.0	16.0	Q1
TMCS1126A5BQDVGR	SOIC	DVG	10	2000	330.0	16.4	10.75	10.7	2.7	12.0	16.0	Q1
TMCS1126A7AQDVGR	SOIC	DVG	10	2000	330.0	16.4	10.75	10.7	2.7	12.0	16.0	Q1
TMCS1126A7BQDVGR	SOIC	DVG	10	2000	330.0	16.4	10.75	10.7	2.7	12.0	16.0	Q1
TMCS1126A8AQDVGR	SOIC	DVG	10	2000	330.0	16.4	10.75	10.7	2.7	12.0	16.0	Q1
TMCS1126A8BQDVGR	SOIC	DVG	10	2000	330.0	16.4	10.75	10.7	2.7	12.0	16.0	Q1
TMCS1126B1AQDVGR	SOIC	DVG	10	2000	330.0	16.4	10.75	10.7	2.7	12.0	16.0	Q1
TMCS1126B1BQDVGR	SOIC	DVG	10	2000	330.0	16.4	10.75	10.7	2.7	12.0	16.0	Q1

Device	Package Type	Package Drawing	Pins	SPQ	Reel Diameter (mm)	Reel Width W1 (mm)	A0 (mm)	B0 (mm)	K0 (mm)	P1 (mm)	W (mm)	Pin1 Quadrant
TMCS1126B2AQDVGR	SOIC	DVG	10	2000	330.0	16.4	10.75	10.7	2.7	12.0	16.0	Q1
TMCS1126B2BQDVGR	SOIC	DVG	10	2000	330.0	16.4	10.75	10.7	2.7	12.0	16.0	Q1
TMCS1126B3AQDVGR	SOIC	DVG	10	2000	330.0	16.4	10.75	10.7	2.7	12.0	16.0	Q1
TMCS1126B3BQDVGR	SOIC	DVG	10	2000	330.0	16.4	10.75	10.7	2.7	12.0	16.0	Q1
TMCS1126B4AQDVGR	SOIC	DVG	10	2000	330.0	16.4	10.75	10.7	2.7	12.0	16.0	Q1
TMCS1126B4BQDVGR	SOIC	DVG	10	2000	330.0	16.4	10.75	10.7	2.7	12.0	16.0	Q1
TMCS1126B5AQDVGR	SOIC	DVG	10	2000	330.0	16.4	10.75	10.7	2.7	12.0	16.0	Q1
TMCS1126B5BQDVGR	SOIC	DVG	10	2000	330.0	16.4	10.75	10.7	2.7	12.0	16.0	Q1
TMCS1126B6AQDVGR	SOIC	DVG	10	2000	330.0	16.4	10.75	10.7	2.7	12.0	16.0	Q1
TMCS1126B6BQDVGR	SOIC	DVG	10	2000	330.0	16.4	10.75	10.7	2.7	12.0	16.0	Q1
TMCS1126B9BQDVGR	SOIC	DVG	10	2000	330.0	16.4	10.75	10.7	2.7	12.0	16.0	Q1
TMCS1126BABQDVGR	SOIC	DVG	10	2000	330.0	16.4	10.75	10.7	2.7	12.0	16.0	Q1
TMCS1126C1AQDVGR	SOIC	DVG	10	2000	330.0	16.4	10.75	10.7	2.7	12.0	16.0	Q1
TMCS1126C1BQDVGR	SOIC	DVG	10	2000	330.0	16.4	10.75	10.7	2.7	12.0	16.0	Q1
TMCS1126C2AQDVGR	SOIC	DVG	10	2000	330.0	16.4	10.75	10.7	2.7	12.0	16.0	Q1
TMCS1126C2BQDVGR	SOIC	DVG	10	2000	330.0	16.4	10.75	10.7	2.7	12.0	16.0	Q1
TMCS1126C3AQDVGR	SOIC	DVG	10	2000	330.0	16.4	10.75	10.7	2.7	12.0	16.0	Q1
TMCS1126C3BQDVGR	SOIC	DVG	10	2000	330.0	16.4	10.75	10.7	2.7	12.0	16.0	Q1
TMCS1126C4AQDVGR	SOIC	DVG	10	2000	330.0	16.4	10.75	10.7	2.7	12.0	16.0	Q1
TMCS1126C4BQDVGR	SOIC	DVG	10	2000	330.0	16.4	10.75	10.7	2.7	12.0	16.0	Q1
TMCS1126C5AQDVGR	SOIC	DVG	10	2000	330.0	16.4	10.75	10.7	2.7	12.0	16.0	Q1
TMCS1126C5BQDVGR	SOIC	DVG	10	2000	330.0	16.4	10.75	10.7	2.7	12.0	16.0	Q1

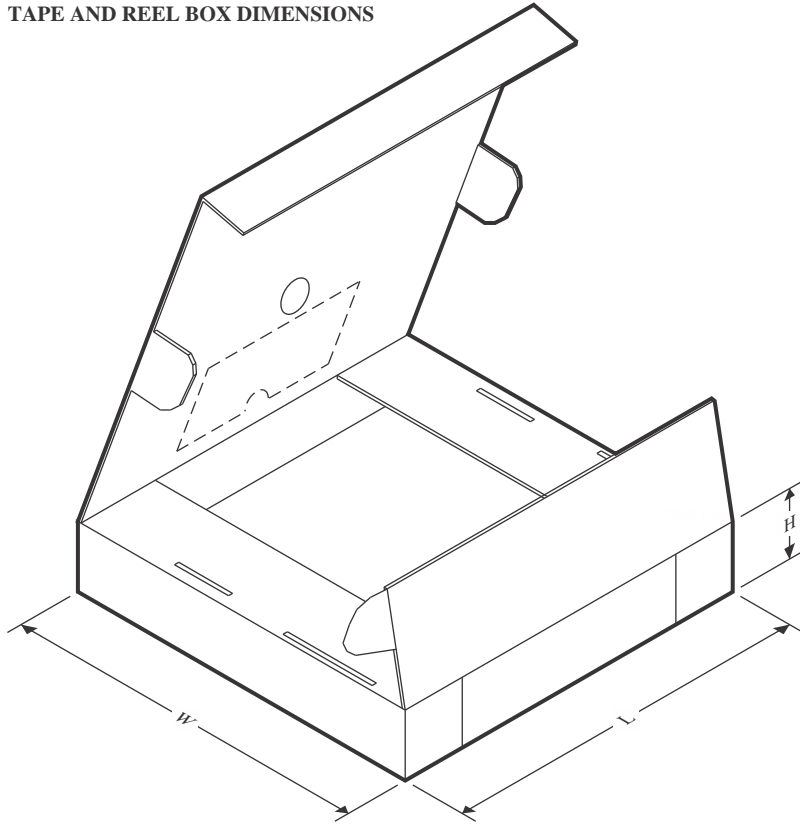
TAPE AND REEL BOX DIMENSIONS

*All dimensions are nominal

Device	Package Type	Package Drawing	Pins	SPQ	Length (mm)	Width (mm)	Height (mm)
TMCS1126A1AQDVGR	SOIC	DVG	10	2000	350.0	350.0	43.0
TMCS1126A1BQDVGR	SOIC	DVG	10	2000	350.0	350.0	43.0
TMCS1126A2AQDVGR	SOIC	DVG	10	2000	350.0	350.0	43.0
TMCS1126A2BQDVGR	SOIC	DVG	10	2000	350.0	350.0	43.0
TMCS1126A3AQDVGR	SOIC	DVG	10	2000	350.0	350.0	43.0
TMCS1126A3BQDVGR	SOIC	DVG	10	2000	350.0	350.0	43.0
TMCS1126A4AQDVGR	SOIC	DVG	10	2000	350.0	350.0	43.0
TMCS1126A4BQDVGR	SOIC	DVG	10	2000	350.0	350.0	43.0
TMCS1126A5AQDVGR	SOIC	DVG	10	2000	350.0	350.0	43.0
TMCS1126A5BQDVGR	SOIC	DVG	10	2000	350.0	350.0	43.0
TMCS1126A7AQDVGR	SOIC	DVG	10	2000	350.0	350.0	43.0
TMCS1126A7BQDVGR	SOIC	DVG	10	2000	350.0	350.0	43.0
TMCS1126A8AQDVGR	SOIC	DVG	10	2000	350.0	350.0	43.0
TMCS1126A8BQDVGR	SOIC	DVG	10	2000	350.0	350.0	43.0
TMCS1126B1AQDVGR	SOIC	DVG	10	2000	350.0	350.0	43.0
TMCS1126B1BQDVGR	SOIC	DVG	10	2000	350.0	350.0	43.0
TMCS1126B2AQDVGR	SOIC	DVG	10	2000	350.0	350.0	43.0
TMCS1126B2BQDVGR	SOIC	DVG	10	2000	350.0	350.0	43.0

Device	Package Type	Package Drawing	Pins	SPQ	Length (mm)	Width (mm)	Height (mm)
TMCS1126B3AQDVGR	SOIC	DVG	10	2000	350.0	350.0	43.0
TMCS1126B3BQDVGR	SOIC	DVG	10	2000	350.0	350.0	43.0
TMCS1126B4AQDVGR	SOIC	DVG	10	2000	350.0	350.0	43.0
TMCS1126B4BQDVGR	SOIC	DVG	10	2000	350.0	350.0	43.0
TMCS1126B5AQDVGR	SOIC	DVG	10	2000	350.0	350.0	43.0
TMCS1126B5BQDVGR	SOIC	DVG	10	2000	350.0	350.0	43.0
TMCS1126B6AQDVGR	SOIC	DVG	10	2000	350.0	350.0	43.0
TMCS1126B6BQDVGR	SOIC	DVG	10	2000	350.0	350.0	43.0
TMCS1126B9BQDVGR	SOIC	DVG	10	2000	350.0	350.0	43.0
TMCS1126BABQDVGR	SOIC	DVG	10	2000	350.0	350.0	43.0
TMCS1126C1AQDVGR	SOIC	DVG	10	2000	350.0	350.0	43.0
TMCS1126C1BQDVGR	SOIC	DVG	10	2000	350.0	350.0	43.0
TMCS1126C2AQDVGR	SOIC	DVG	10	2000	350.0	350.0	43.0
TMCS1126C2BQDVGR	SOIC	DVG	10	2000	350.0	350.0	43.0
TMCS1126C3AQDVGR	SOIC	DVG	10	2000	350.0	350.0	43.0
TMCS1126C3BQDVGR	SOIC	DVG	10	2000	350.0	350.0	43.0
TMCS1126C4AQDVGR	SOIC	DVG	10	2000	350.0	350.0	43.0
TMCS1126C4BQDVGR	SOIC	DVG	10	2000	350.0	350.0	43.0
TMCS1126C5AQDVGR	SOIC	DVG	10	2000	350.0	350.0	43.0
TMCS1126C5BQDVGR	SOIC	DVG	10	2000	350.0	350.0	43.0