

# ADS981x 18-Bit, 2-MSPS/Ch, Dual, Simultaneous-Sampling ADC With Integrated Analog Front-End

## 1 Features

- 8-channel, 18-bit ADC with analog front-end:
  - Dual, simultaneous sampling:  $4 \times 1$  channels
  - Constant  $1\text{M}\Omega$  input impedance front-end
- Programmable analog input ranges:
  - $\pm 12\text{V}$ ,  $\pm 10\text{V}$ ,  $\pm 7\text{V}$ ,  $\pm 5\text{V}$ ,  $\pm 3.5\text{V}$ , and  $\pm 2.5\text{V}$
  - Single-ended and differential inputs
  - $\pm 12\text{V}$  common-mode voltage range
  - Input overvoltage protection: Up to  $\pm 18\text{V}$
- User-selectable analog input bandwidth:
  - 21kHz and 400kHz
- Integrated low-drift precision references
  - ADC reference: 4.096V
  - 2.5V reference output for external circuits
- Excellent AC and DC performance at full-throughput:
  - DNL:  $\pm 0.5\text{LSB}$ , INL:  $\pm 0.8\text{LSB}$
  - SNR: 92dB, THD:  $-113\text{dB}$
- Power supply:
  - Analog and digital: 5V and 1.8V
  - Digital interface: 1.2V to 1.8V
- Temperature range:  $-40^\circ\text{C}$  to  $+125^\circ\text{C}$

## 2 Applications

- Parametric measurement units (PMU)
- Battery cell formation and test equipment
- Data acquisition (DAQ)

## 3 Description

The ADS981x is an 8-channel data acquisition (DAQ) system based on a dual, simultaneous-sampling, 18-bit successive approximation register (SAR) analog-to-digital converter (ADC). The ADS981x features a complete analog front-end for each channel with an input clamp protection circuit,  $1\text{M}\Omega$  input impedance, and a programmable gain amplifier (PGA) with user-selectable bandwidth options. The high input impedance allows direct connection with sensors and transformers, thus eliminating the need for external driver circuits. The ADS981x can be configured to accept unipolar or bipolar inputs with up to a  $\pm 12\text{V}$  common-mode voltage.

The device also features a 4.096V reference for the ADC and a 2.5V reference output for use with external circuits. A digital interface supporting 1.2V to 1.8V operation enables the ADS981x to be used without external voltage level translators.

### Package Information

PART NUMBER	PACKAGE <sup>(1)</sup>	PACKAGE SIZE <sup>(2)</sup>
ADS981x	RSH (VQFN, 56)	7mm × 7mm

- For more information, see the [Mechanical, Packaging, and Orderable Information](#).
- The package size (length × width) is a nominal value and includes pins, where applicable.

### Device Information

PART NUMBER	SPEED	TOTAL POWER
ADS9817	2MSPS/channel	232mW
ADS9815	1MSPS/channel	165mW

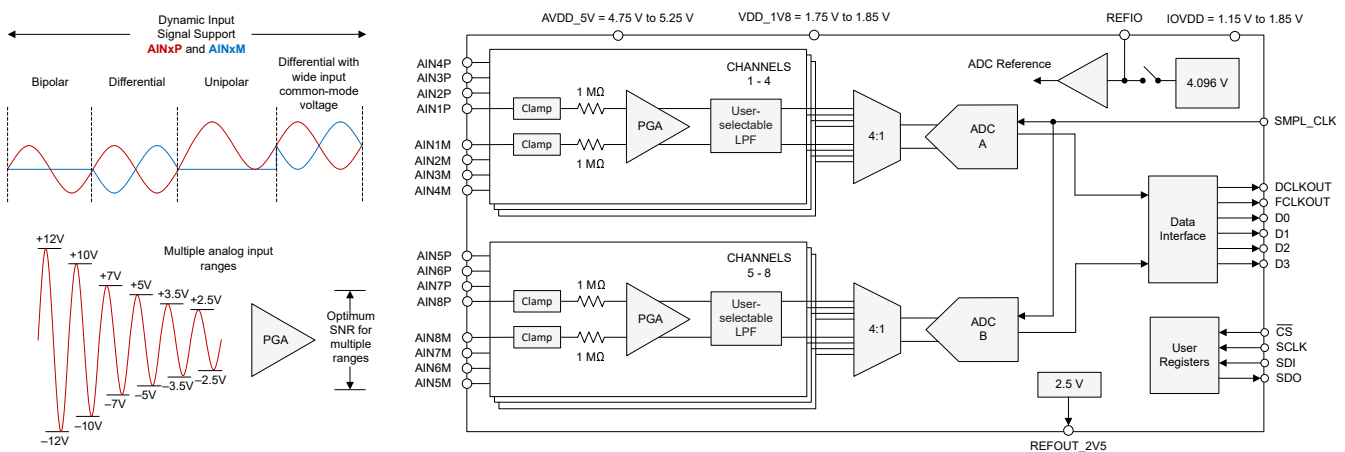

Device Block Diagram



## Table of Contents

<b>1 Features</b> .....	1	6.5 Programming.....	34
<b>2 Applications</b> .....	1	<b>7 Register Map</b> .....	39
<b>3 Description</b> .....	1	7.1 Register Bank 0 .....	39
<b>4 Pin Configuration and Functions</b> .....	3	7.2 Register Bank 1.....	42
<b>5 Specifications</b> .....	5	7.3 Register Bank 2 .....	56
5.1 Absolute Maximum Ratings.....	5	<b>8 Application and Implementation</b> .....	58
5.2 ESD Ratings.....	5	8.1 Application Information.....	58
5.3 Recommended Operating Conditions.....	6	8.2 Typical Application.....	58
5.4 Thermal Information.....	6	8.3 Power Supply Recommendations.....	62
5.5 Electrical Characteristics.....	7	8.4 Layout.....	62
5.6 Timing Requirements.....	10	<b>9 Device and Documentation Support</b> .....	64
5.7 Switching Characteristics.....	11	9.1 Receiving Notification of Documentation Updates...	64
5.8 Timing Diagrams.....	11	9.2 Support Resources.....	64
5.9 Typical Characteristics.....	14	9.3 Trademarks.....	64
<b>6 Detailed Description</b> .....	21	9.4 Electrostatic Discharge Caution.....	64
6.1 Overview.....	21	9.5 Glossary.....	64
6.2 Functional Block Diagram.....	21	<b>10 Revision History</b> .....	64
6.3 Feature Description.....	22	<b>11 Mechanical, Packaging, and Orderable Information</b> .....	65
6.4 Device Functional Modes.....	31		

## 4 Pin Configuration and Functions

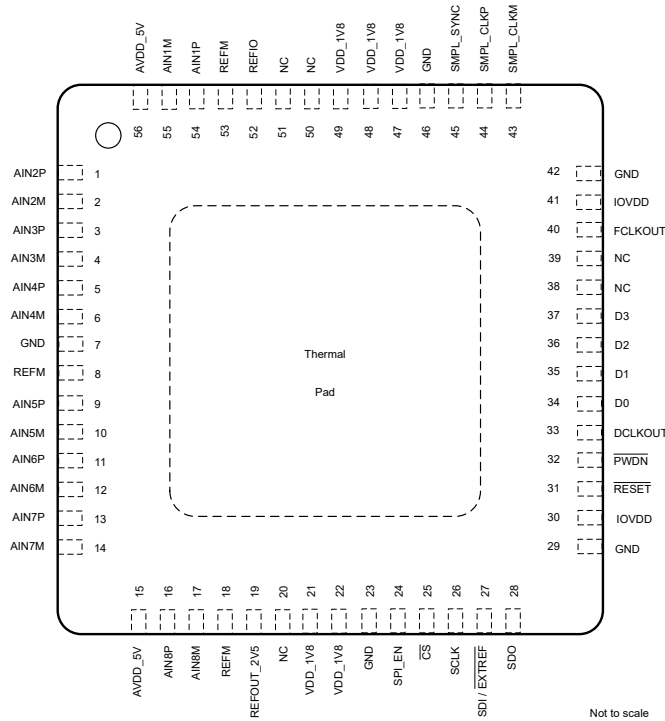

**Figure 4-1. RSH Package, 56-Pin VQFN (Top View)**

**Table 4-1. Pin Functions**

PIN		TYPE <sup>(1)</sup>	DESCRIPTION
NAME	NO.		
AIN1M	55	AI	Analog input channel 1, negative input.
AIN1P	54	AI	Analog input channel 1, positive input.
AIN2M	2	AI	Analog input channel 2, negative input.
AIN2P	1	AI	Analog input channel 2, positive input.
AIN3M	4	AI	Analog input channel 3, negative input.
AIN3P	3	AI	Analog input channel 3, positive input.
AIN4M	6	AI	Analog input channel 4, negative input.
AIN4P	5	AI	Analog input channel 4, positive input.
AIN5M	10	AI	Analog input channel 5, negative input.
AIN5P	9	AI	Analog input channel 5, positive input.
AIN6M	12	AI	Analog input channel 6, negative input.
AIN6P	11	AI	Analog input channel 6, positive input.
AIN7M	14	AI	Analog input channel 7, negative input.
AIN7P	13	AI	Analog input channel 7, positive input.
AIN8M	17	AI	Analog input channel 8, negative input.
AIN8P	16	AI	Analog input channel 8, positive input.
AVDD_5V	15, 56	P	5V analog supply. Connect 1µF and 0.1µF decoupling capacitors to GND.
$\overline{CS}$	25	DI	Chip-select input for SPI interface configuration; active low. This pin has an internal 100kΩ pullup resistor to IOVDD.
D0	34	DO	Serial output data lane 0.
D1	35	DO	Serial data output lane 1.

**Table 4-1. Pin Functions (continued)**

PIN		TYPE <sup>(1)</sup>	DESCRIPTION
NAME	NO.		
D2	36	DO	Serial data output lane 2.
D3	37	DO	Serial data output lane 3.
DCLKOUT	33	DO	Clock output for data interface.
FCLKOUT	40	DO	Frame synchronization output for data interface.
GND	7, 23, 29, 42, 46	P	Ground.
IOVDD	30, 41	P	Digital I/O supply for data interface. Connect 1µF and 0.1µF decoupling capacitor to GND.
NC	20, 38, 39, 50, 51	—	Not connected. No external connection.
PWDN	32	DI	Power-down control; active low. $\overline{\text{PWDN}}$ has an internal 100kΩ pullup resistor to the digital interface supply.
REFIO	52	AI/AO	REFIO acts as an internal reference output when the internal reference is enabled. REFIO functions as an input pin for the external reference when the internal reference is disabled. Connect a 10µF decoupling capacitor to the REFM pins.
REFM	8, 18, 53	AI	Reference ground potential. Connect to GND.
REFOUT_2V5	19	AO	2.5V reference output. Connect a decoupling 10µF capacitor to the REFM pins.
$\overline{\text{RESET}}$	31	DI	Reset input for the device; active low. $\overline{\text{RESET}}$ has an internal 100kΩ pullup resistor to the digital interface supply.
SCLK	26	DI	Serial clock input for the configuration interface. SCLK has an internal 100kΩ pulldown resistor to the digital interface ground.
SDI	27	DI	SDI is a multifunction logic input; pin function is determined by the SPI_EN pin. SDI has an internal 100kΩ pulldown resistor to GND. SPI_EN = 0b: SDI is the logic input to select between the internal or external reference. Connect SDI to GND for the external reference. Connect SDI to IOVDD for the internal reference. SPI_EN = 1b: Serial data input for the configuration interface.
SDO	28	DO	Serial data output for the configuration interface.
SMPL_CLKP	44	DI	Single-ended ADC sampling clock input. SMPL_CLKP is the positive input for the differential sampling clock input to the ADC.
SMPL_CLKM	43	DI	Connect SMPL_CLKM to GND for a single-ended ADC sampling clock input. SMPL_CLKM is the negative input for the differential sampling clock input to the ADC.
SMPL_SYNC	45	DI	Synchronization input. See the <a href="#">Sample Synchronization</a> section on how to use the SMPL_SYNC pin.
SPI_EN	24	DI	Logic input to enable the SPI interface configuration ( $\overline{\text{CS}}$ , SCLK, SDI, and SDO). SPI_EN has an internal 100kΩ pullup resistor to the digital interface supply.
VDD_1V8	21, 22, 47, 48, 49	P	1.8V power-supply. Connect 1µF and 0.1µF decoupling capacitors to GND.
Thermal pad	—	P	Exposed thermal pad; connect to GND.

(1) I = input, O = output, I/O = input or output, G = ground, and P = power.

## 5 Specifications

### 5.1 Absolute Maximum Ratings

over operating ambient temperature range (unless otherwise noted)<sup>(1)</sup>

	MIN	MAX	UNIT
AVDD_5V to GND	-0.3	6	V
VDD_1V8 to GND	-0.3	2.1	V
IOVDD to GND	-0.3	2.1	V
AINxP and AINxM to GND	-18	18	V
REFIO to REFM	REFM - 0.3	AVDD_5V + 0.3	V
REFM to GND	GND - 0.3	GND + 0.3	V
Digital inputs to GND	GND - 0.3	2.1	V
Input current to any pin except supply pins <sup>(2)</sup>	-10	10	mA
Junction temperature, T <sub>J</sub>	-40	150	°C
Storage temperature, T <sub>stg</sub>	-60	150	°C

- (1) Operation outside the Absolute Maximum Ratings may cause permanent device damage. *Absolute Maximum Ratings* do not imply functional operation of the device at these or any other conditions beyond those listed under *Recommended Operating Conditions*. If used outside the *Recommended Operating Conditions* but within the *Absolute Maximum Ratings*, the device may not be fully functional, and this may affect device reliability, functionality, performance, and shorten the device lifetime.
- (2) Pin current must be limited to 10 mA or less.

### 5.2 ESD Ratings

			VALUE	UNIT
V <sub>(ESD)</sub>	Electrostatic discharge	Human body model (HBM), per ANSI/ESDA/JEDEC JS-001, all pins <sup>(1)</sup>	±2000	V
		Charged device model (CDM), per JEDEC specification JESD22-C101, all pins <sup>(2)</sup>	±500	

- (1) JEDEC document JEP155 states that 500V HBM allows safe manufacturing with a standard ESD control process.
- (2) JEDEC document JEP157 states that 250V CDM allows safe manufacturing with a standard ESD control process.

### 5.3 Recommended Operating Conditions

over operating free-air temperature range (unless otherwise noted)

PARAMETER		TEST CONDITIONS	MIN	TYP	MAX	UNIT
<b>POWER SUPPLY</b>						
AVDD_5V	Analog power supply	AVDD_5V to GND, 5 V	4.75	5	5.25	V
VDD_1V8	Analog power supply	VDD_1V8 to GND, 1.8 V	1.75	1.8	1.85	V
IOVDD	Digital interface power supply	IOVDD to GND	1.15	1.8	1.85	V
<b>REFERENCE VOLTAGE</b>						
V <sub>REF</sub>	Reference voltage to the ADC	External reference	4.092	4.096	4.100	V
<b>ANALOG INPUTS</b>						
V <sub>FSR</sub>	Full-scale input range	RANGE_CHx = 0010b	-2.5		2.5	V
		RANGE_CHx = 0001b	-3.5		3.5	
		RANGE_CHx = 0000b	-5		5	
		RANGE_CHx = 0011b	-7		7	
		RANGE_CHx = 0100b	-10		10	
		RANGE_CHx = 0101b	-12		12	
AINxP	Operating input voltage, positive input		-17		17	V
AINxM	Operating input voltage, negative input		-17		17	V
<b>TEMPERATURE RANGE</b>						
T <sub>A</sub>	Ambient temperature		-40	25	125	°C

### 5.4 Thermal Information

THERMAL METRIC <sup>(1)</sup>		ADS981x	UNIT
		RSH (VQFN)	
		56 PINS	
R <sub>θJA</sub>	Junction-to-ambient thermal resistance	23.2	°C/W
R <sub>θJC(top)</sub>	Junction-to-case (top) thermal resistance	10.5	°C/W
R <sub>θJB</sub>	Junction-to-board thermal resistance	6.1	°C/W
Ψ <sub>JT</sub>	Junction-to-top characterization parameter	0.1	°C/W
Ψ <sub>JB</sub>	Junction-to-board characterization parameter	6.0	°C/W
R <sub>θJC(bot)</sub>	Junction-to-case (bottom) thermal resistance	0.9	°C/W

(1) For more information about traditional and new thermal metrics, see the [Semiconductor and IC Package Thermal Metrics](#) application note.

## 5.5 Electrical Characteristics

at AVDD\_5V = 4.75 V to 5.25 V, VDD\_1V8 = 1.75 V to 1.85 V, IOVDD = 1.15 V to 1.85 V, V<sub>REF</sub> = 4.096 V (internal or external), wide-common-mode disabled for analog input ranges ±2.5V, ±3.5V, and ±5V, wide-common-mode enabled for analog input ranges ±7V, ±10V, and ±12V, and maximum throughput (unless otherwise noted); minimum and maximum values at T<sub>A</sub> = -40°C to +125°C; typical values at T<sub>A</sub> = 25°C

PARAMETER		TEST CONDITIONS	MIN	TYP	MAX	UNIT
<b>ANALOG INPUTS</b>						
R <sub>IN</sub>	Input impedance	All input ranges	0.85	1	1.15	MΩ
	Input impedance thermal drift	All input ranges		10	25	ppm/°C
	Input capacitance			10		pF
<b>ANALOG INPUT FILTER</b>						
BW <sub>(-3 dB)</sub>	Analog input LPF bandwidth -3 dB	All input ranges, low-bandwidth filter		21		kHz
		RANGE = ±2.5V, wide-bandwidth filter		182		
		RANGE = ±3.5V, wide-bandwidth filter		240		
		RANGE = ±5V, wide-bandwidth filter		320		
		RANGE = ±7V, wide-bandwidth filter		400		
		RANGE = ±10V, wide-bandwidth filter		385		
		RANGE = ±12V, wide-bandwidth filter		375		
<b>DC PERFORMANCE</b>						
	Resolution	No missing codes	18			Bits
DNL	Differential nonlinearity <sup>(3)</sup>	All ranges, wide-CM enabled and disabled	-0.99	±0.5	0.99	LSB
INL	Integral nonlinearity	All ranges, wide-CM enabled and disabled, T <sub>A</sub> = 0°C to 70°C	-4	±0.8	4	LSB
		All ranges, wide-CM enabled and disabled, T <sub>A</sub> = -40°C to 125°C	-4.5	±0.8	4.5	LSB
	Offset error <sup>(2) (5)</sup>	RANGE = ±2.5V	-175	±90	175	LSB
		RANGE = ±2.5V, wide-CM enabled		±120		
		RANGE = ±3.5V	-100	±60	100	
		RANGE = ±3.5V, wide-CM enabled		±80		
		RANGE = ±5V	-50	±10	50	
		RANGE = ±5V, wide-CM enabled		±60		
		RANGE = ±7V	-100	±35	100	
		RANGE = ±10V	-50	±10	50	
	Offset error thermal drift <sup>(2) (4)</sup>	All ranges, wide-CM enabled and disabled		0.5	1.5	ppm/°C
	Gain error <sup>(2) (5)</sup>	RANGE = ±2.5V, ±3.5V, and ±5V	-0.05	±0.02	0.05	%FSR
		RANGE = ±2.5V, ±3.5V, and ±5V, wide-CM enabled		±0.04		
		RANGE = ±7V, ±10V, ±12V	-0.05	±0.02	0.05	
	Gain error thermal drift <sup>(2) (4)</sup>	Wide-CM enabled and disabled, all ranges		0.7	3	ppm/°C
<b>AC PERFORMANCE</b>						

### 5.5 Electrical Characteristics (continued)

at AVDD\_5V = 4.75 V to 5.25 V, VDD\_1V8 = 1.75 V to 1.85 V, IOVDD = 1.15 V to 1.85 V, V<sub>REF</sub> = 4.096 V (internal or external), wide-common-mode disabled for analog input ranges ±2.5V, ±3.5V, and ±5V, wide-common-mode enabled for analog input ranges ±7V, ±10V, and ±12V, and maximum throughput (unless otherwise noted); minimum and maximum values at T<sub>A</sub> = -40°C to +125°C; typical values at T<sub>A</sub> = 25°C

PARAMETER		TEST CONDITIONS	MIN	TYP	MAX	UNIT
SNR	Signal-to-noise ratio, low-noise filter	RANGE = ±2.5V, f <sub>IN</sub> = 2kHz	86.7	89.5		dBFS
		RANGE = ±3.5V, f <sub>IN</sub> = 2kHz	87.8	90.5		
		RANGE = ±5V, f <sub>IN</sub> = 2kHz	88.5	91.4		
		RANGE = ±7V, f <sub>IN</sub> = 2kHz	89.3	91.3		
		RANGE = ±10V, f <sub>IN</sub> = 2kHz	89.9	91.8		
		RANGE = ±12V, f <sub>IN</sub> = 2kHz	90	92		
	Signal-to-noise ratio, wide-bandwidth filter	RANGE = ±2.5V, f <sub>IN</sub> = 2kHz	79	82.5		
		RANGE = ±3.5V, f <sub>IN</sub> = 2kHz	80	83.5		
		RANGE = ±5V, f <sub>IN</sub> = 2kHz	80.5	84.5		
		RANGE = ±7V, f <sub>IN</sub> = 2kHz	81.5	83.5		
		RANGE = ±10V, f <sub>IN</sub> = 2kHz	83	85		
		RANGE = ±12V, f <sub>IN</sub> = 2kHz	83.5	85.5		
SINAD	Signal-to-noise + distortion ratio, low-noise filter	RANGE = ±2.5V, f <sub>IN</sub> = 2kHz	85.7	88.9		dB
		RANGE = ±3.5V, f <sub>IN</sub> = 2kHz	86.7	89.9		
		RANGE = ±5V, f <sub>IN</sub> = 2kHz	87.3	90.7		
		RANGE = ±7V, f <sub>IN</sub> = 2kHz	88.0	90.6		
		RANGE = ±10V, f <sub>IN</sub> = 2kHz	88.5	91.1		
		RANGE = ±12V, f <sub>IN</sub> = 2kHz	88.6	91.3		
	Signal-to-noise + distortion ratio, wide-bandwidth filter	RANGE = ±2.5V, f <sub>IN</sub> = 2kHz	78.6	82.2		
		RANGE = ±3.5V, f <sub>IN</sub> = 2kHz	79.5	83.2		
		RANGE = ±5V, f <sub>IN</sub> = 2kHz	80.0	84.2		
		RANGE = ±7V, f <sub>IN</sub> = 2kHz	80.9	83.2		
		RANGE = ±10V, f <sub>IN</sub> = 2kHz	82.3	84.7		
		RANGE = ±12V, f <sub>IN</sub> = 2kHz	82.8	85.1		
THD	Total harmonic distortion	All ranges, low-noise filter, f <sub>IN</sub> = 2kHz		-113		dB
		All ranges, wide-bandwidth filter, f <sub>IN</sub> = 2kHz		-113		
SFDR	Spurious-free dynamic range	All ranges, f <sub>IN</sub> = 2kHz		113		dB
	CMRR	at dc		-70		dB
	Isolation crosstalk	at dc		-100		dB
<b>INTERNAL REFERENCE</b>						
V <sub>REF</sub> <sup>(1)</sup>	Voltage on REFIO pin (configured as output)	1μF capacitor on REFIO pin, T <sub>A</sub> = 25°C	4.092	4.096	4.1	V
	Reference temperature drift <sup>(4)</sup>			10	25	ppm/°C



## 5.5 Electrical Characteristics (continued)

at AVDD\_5V = 4.75 V to 5.25 V, VDD\_1V8 = 1.75 V to 1.85 V, IOVDD = 1.15 V to 1.85 V, V<sub>REF</sub> = 4.096 V (internal or external), wide-common-mode disabled for analog input ranges ±2.5V, ±3.5V, and ±5V, wide-common-mode enabled for analog input ranges ±7V, ±10V, and ±12V, and maximum throughput (unless otherwise noted); minimum and maximum values at T<sub>A</sub> = –40°C to +125°C; typical values at T<sub>A</sub> = 25°C

PARAMETER		TEST CONDITIONS	MIN	TYP	MAX	UNIT
<b>DIGITAL INPUTS</b>						
V <sub>IL</sub>	Input low logic level		–0.3	0.3 IOVDD		V
V <sub>IH</sub>	Input high logic level		0.7 IOVDD		IOVDD	V
	Input current			0.1		μA
	Input capacitance			6		pF
<b>LVDS SAMPLING CLOCK INPUT</b>						
V <sub>TH</sub>	High-level input voltage	AC coupled	100			mV
		DC coupled	300			
V <sub>TL</sub>	Low-level input voltage	AC coupled			–100	mV
		DC coupled			–300	
V <sub>ICM</sub>	Input common-mode voltage		0.3	1.2	1.4	V
<b>DIGITAL OUTPUTS</b>						
V <sub>OL</sub>	Output low logic level	I <sub>OL</sub> = 500μA sink	0	0.2 IOVDD		V
V <sub>OH</sub>	Output high logic level	I <sub>OH</sub> = 500μA source	0.8 IOVDD		IOVDD	V
<b>POWER SUPPLY - ADS9817</b>						
	Total power dissipation	Maximum throughput		232	304	mW
I <sub>AVDD_5V</sub>	Supply current from AVDD_5V	Maximum throughput, internal reference		26	32	mA
		Power-down		0.2	2	
I <sub>VDD_1V8</sub>	Supply current from VDD_1V8	Maximum throughput, internal reference		50	70	mA
		Power-down		0.2	8	
I <sub>IOVDD</sub>	Supply current from IOVDD	Maximum throughput		7	10	mA
		Power-down		0.1	3	
<b>POWER SUPPLY - ADS9815</b>						
	Total power dissipation	Maximum throughput		165	215	mW
I <sub>AVDD_5V</sub>	Supply current from AVDD_5V	Maximum throughput, internal reference		19	25	mA
		Power-down		0.2	2	
I <sub>VDD_1V8</sub>	Supply current from VDD_1V8	Maximum throughput, internal reference		35	43	mA
		Power-down		0.2	8	
I <sub>IOVDD</sub>	Supply current from IOVDD	Maximum throughput		4	7	mA
		Power-down		0.1	3	

- (1) Does not include the variation in voltage resulting from solder shift effects.
- (2) These specifications include full temperature range variation but not the error contribution from internal reference. Measured with single-ended inputs as described in [Wide Common-Mode Configuration for Single-Ended Inputs](#)
- (3) Wide-CM refers to wide-common-mode voltage at the analog inputs. See section on [Section 6.3.1.3](#) for more details.
- (4) Thermal drift is the difference between maximum and minimum error measured over the temperature range, divided by the temperature range.
- (5) Minimum and maximum specifications are applicable for low-bandwidth filter setting.

## 5.6 Timing Requirements

at AVDD\_5V = 4.75 V to 5.25 V, VDD\_1V8 = 1.75 V to 1.85 V, IOVDD = 1.15 V to 1.85 V, and maximum throughput (unless otherwise noted); minimum and maximum values at T<sub>A</sub> = -40°C to +125°C; typical values at T<sub>A</sub> = 25°C

			MIN	MAX	UNIT
<b>CONVERSION CYCLE</b>					
f <sub>SMPL_CLK</sub>	Sampling frequency	ADS9817	3.9	8.1	MHz
f <sub>SMPL_CLK</sub>	Sampling frequency	ADS9815	3.9	4.1	MHz
t <sub>SMPL_CLK</sub>	Sampling time interval		1 / f <sub>SMPL_CLK</sub>		ns
t <sub>PL_SMPL_CLK</sub>	SMPL_CLK low time		0.45 t <sub>SMPL_CLK</sub>	0.55 t <sub>SMPL_CLK</sub>	ns
t <sub>PH_SMPL_CLK</sub>	SMPL_CLK high time		0.45 t <sub>SMPL_CLK</sub>	0.55 t <sub>SMPL_CLK</sub>	ns
<b>SPI INTERFACE TIMINGS (CONFIGURATION INTERFACE)</b>					
f <sub>SCLK</sub>	Maximum SCLK frequency			20	MHz
t <sub>PH_CK</sub>	SCLK high time		0.48	0.52	t <sub>CLK</sub>
t <sub>PL_CK</sub>	SCLK low time		0.48	0.52	t <sub>CLK</sub>
t <sub>hi_CS</sub>	Pulse duration: $\overline{CS}$ high		220		ns
t <sub>d_CSCK</sub>	Delay time: $\overline{CS}$ falling to the first SCLK capture edge		20		ns
t <sub>su_CKDI</sub>	Setup time: SDI data valid to the SCLK rising edge		10		ns
t <sub>ht_CKDI</sub>	Hold time: SCLK rising edge to data valid on SDI		5		ns
t <sub>D_CKCS</sub>	Delay time: last SCLK falling to $\overline{CS}$ rising		5		ns
<b>CMOS DATA INTERFACE</b>					
t <sub>su_SS</sub>	Setup time: SMPL_SYNC rising edge to SMPL_CLK falling edge		10		ns
t <sub>ht_SS</sub>	Hold time: SMPL_CLK falling edge to SMPL_SYNC high		10		ns

### 5.7 Switching Characteristics

at AVDD\_5V = 4.75 V to 5.25 V, VDD\_1V8 = 1.75 V to 1.85 V, IOVDD = 1.15 V to 1.85 V, and maximum throughput (unless otherwise noted); minimum and maximum values at T<sub>A</sub> = -40°C to +125°C; typical values at T<sub>A</sub> = 25°C

PARAMETER		TEST CONDITIONS	MIN	MAX	UNIT
<b>RESET</b>					
t <sub>PU</sub>	Power-up time for device			25	ms
<b>SPI INTERFACE TIMINGS (CONFIGURATION INTERFACE)</b>					
t <sub>den_CKDO</sub>	Delay time: 8 <sup>th</sup> SCLK rising edge to data enable			22	ns
t <sub>dz_CKDO</sub>	Delay time: 24 <sup>th</sup> SCLK rising edge to SDO going Hi-Z			50	ns
t <sub>d_CKDO</sub>	Delay time: SCLK falling edge to corresponding data valid on SDO			16	ns
t <sub>ht_CKDO</sub>	Delay time: SCLK falling edge to previous data valid on SDO		2		ns
<b>CMOS DATA INTERFACE</b>					
t <sub>DCLK</sub>	Data clock output	DDR mode	10		ns
		SDR mode	20		
	Clock duty cycle		45	55	%
t <sub>off_DCLKDO_r</sub>	Time offset: DCLK rising to corresponding data valid	DDR mode	t <sub>DCLK</sub> / 4 - 1.5	t <sub>DCLK</sub> / 4 + 1.5	ns
t <sub>off_DCLKDO_f</sub>	Time offset: DCLK falling to corresponding data valid	DDR mode	t <sub>DCLK</sub> / 4 - 1.5	t <sub>DCLK</sub> / 4 + 1.5	ns
t <sub>d_DCLKDO</sub>	Time delay: DCLK rising to corresponding data valid	SDR mode	-1	1	ns
t <sub>d_SYNC_FCLK</sub>	Time delay: SMPL_CLK falling edge with SYNC signal to corresponding FCLKOUT rising edge		3	4	t <sub>SMPL_CLK</sub>

### 5.8 Timing Diagrams

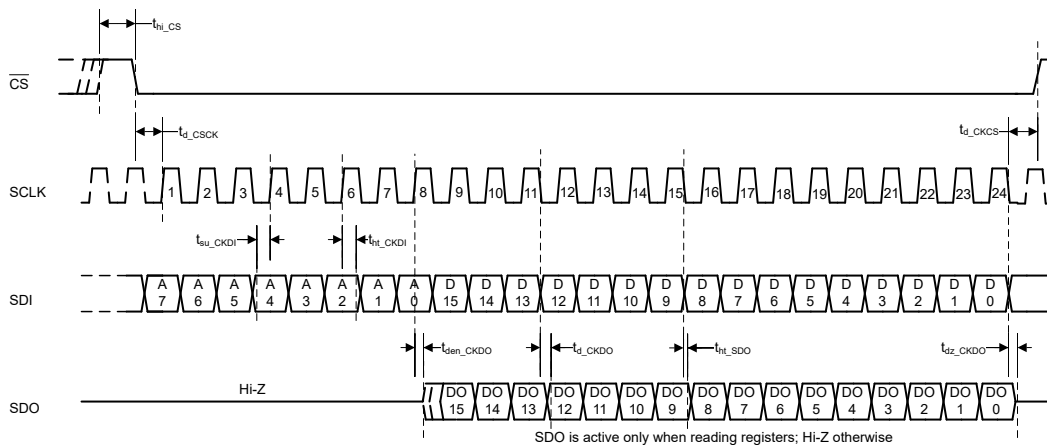
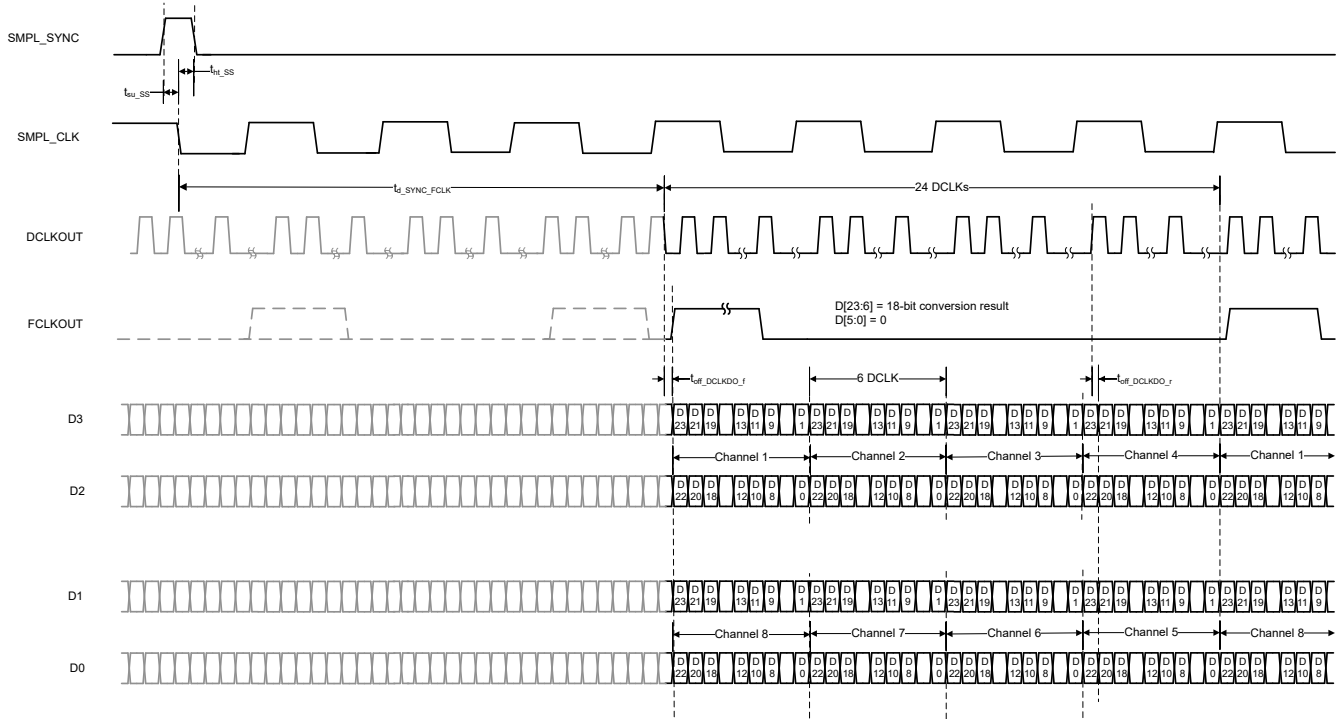
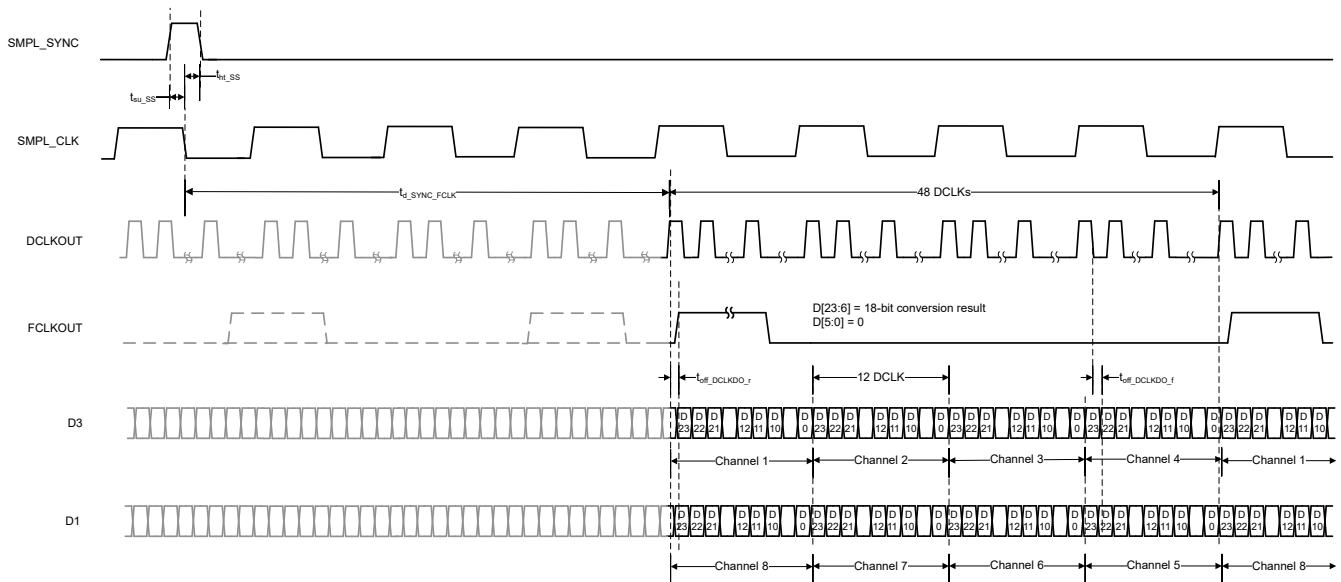

Figure 5-1. SPI Configuration Interface



**Figure 5-2. 4-SDO DDR CMOS Data Interface**



**Figure 5-3. 2-SDO DDR CMOS Data Interface**

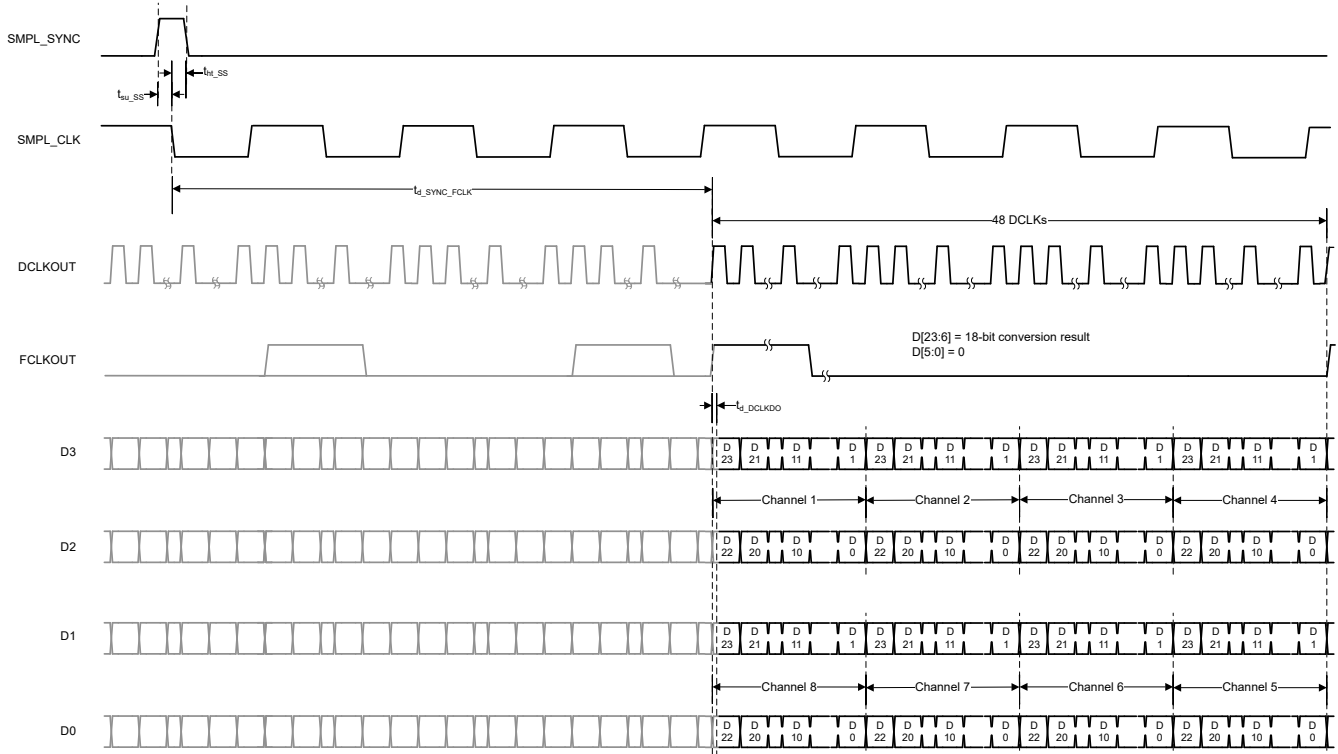

**Figure 5-4. 4-SDO SDR CMOS Data Interface**

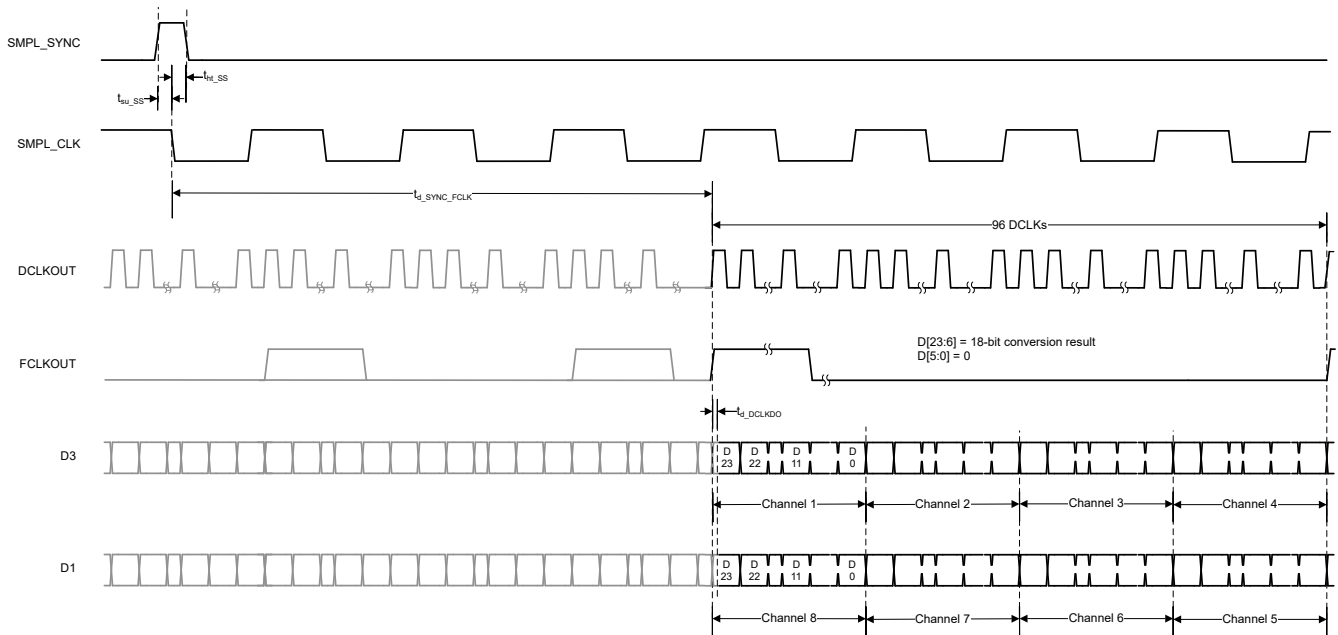

**Figure 5-5. 2-SDO SDR CMOS Data Interface**

## 5.9 Typical Characteristics

at  $T_A = 25^\circ\text{C}$ ,  $AVDD_{5V} = 5\text{V}$ ,  $VDD_{1V8} = 1.8\text{V}$ , internal  $V_{REF} = 4.096\text{V}$ ,  $\pm 5\text{V}$  analog input range, and maximum throughput (unless otherwise noted)

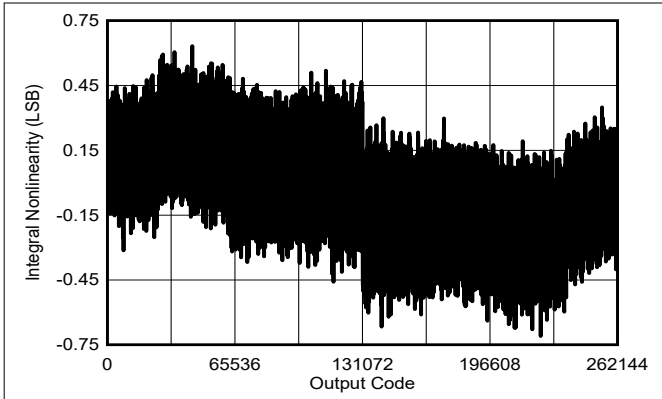

Figure 5-6. Typical INL With Low-Bandwidth LPF

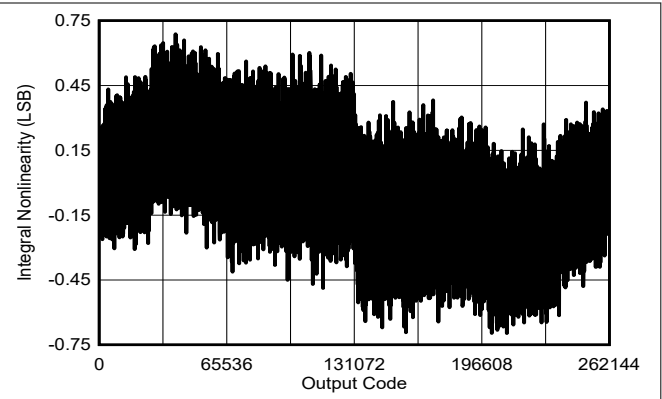

Figure 5-7. Typical INL With Wide-Bandwidth LPF

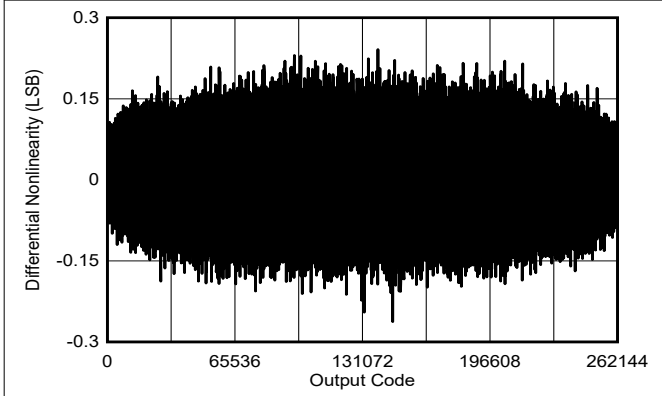

Figure 5-8. Typical DNL With Low-Noise LPF

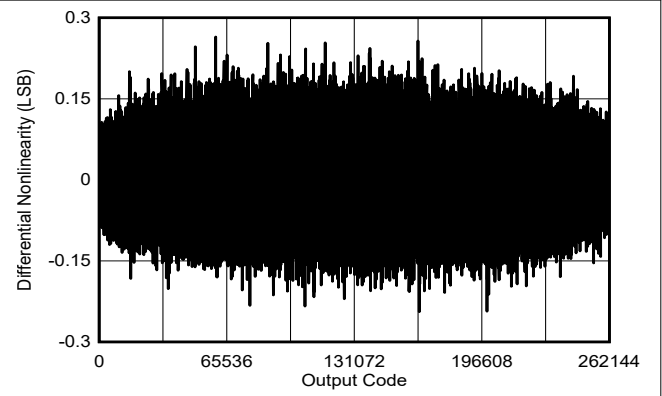

Figure 5-9. Typical DNL With Wide-Bandwidth LPF

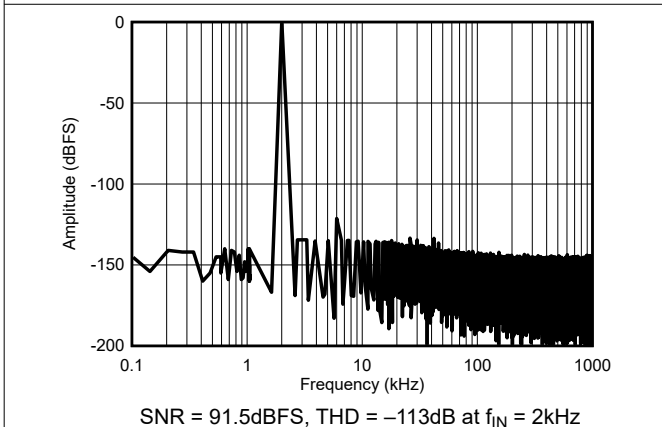

Figure 5-10. Typical FFT With Low-Bandwidth LPF, RANGE =  $\pm 5\text{V}$

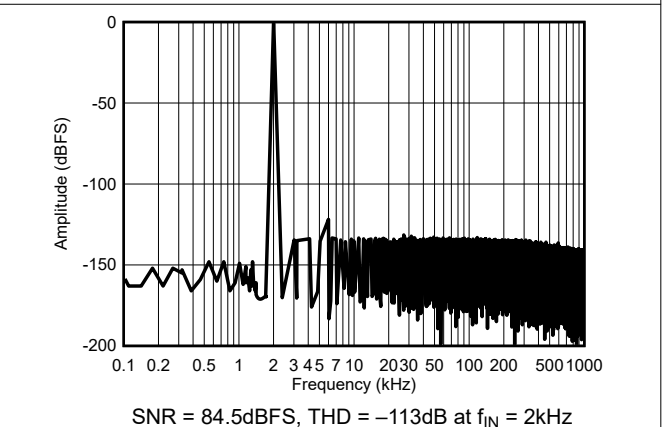
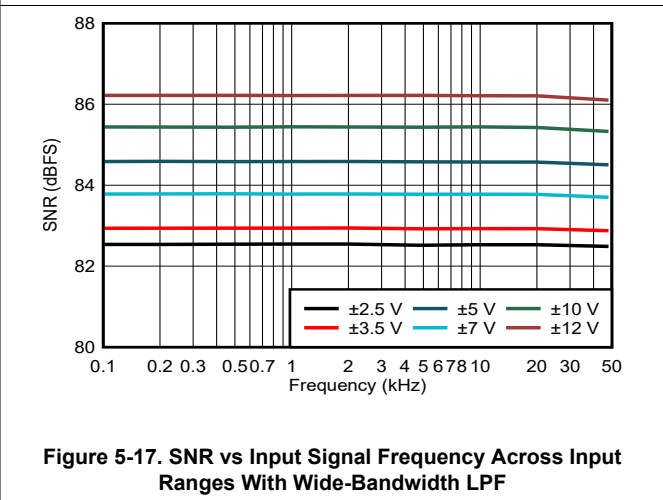
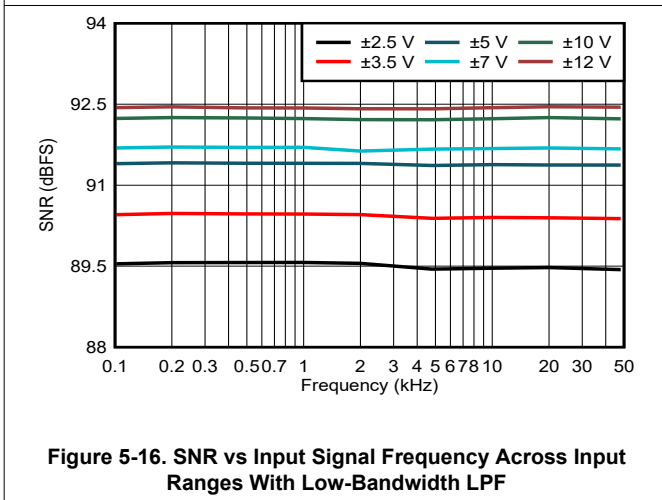
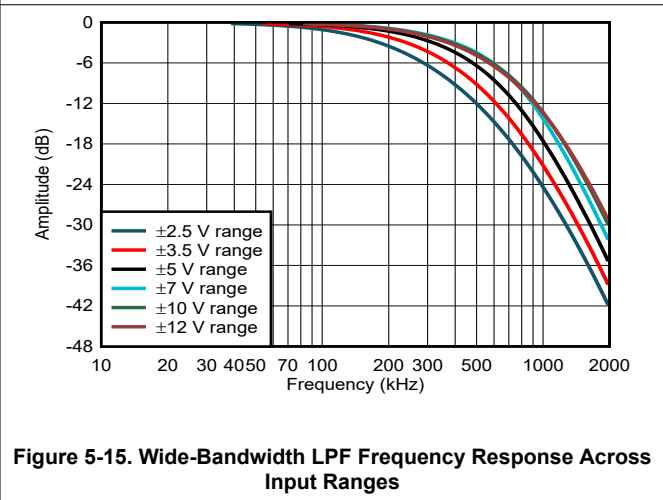
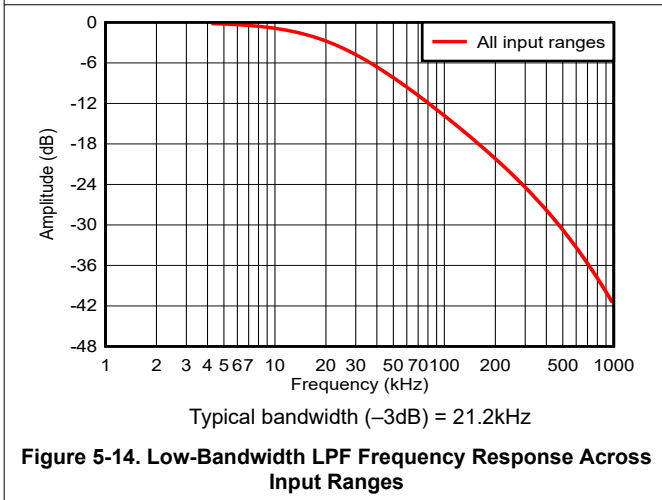
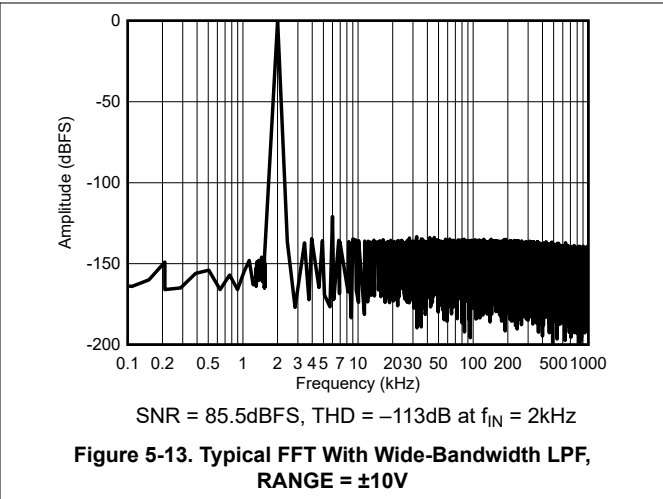
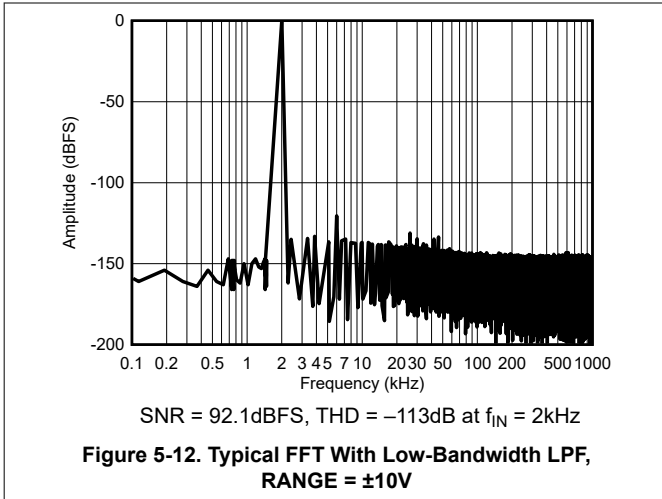

Figure 5-11. Typical FFT With Wide-Bandwidth LPF, RANGE =  $\pm 5\text{V}$

### 5.9 Typical Characteristics (continued)

at  $T_A = 25^\circ\text{C}$ ,  $AVDD_{5V} = 5V$ ,  $VDD_{1V8} = 1.8V$ , internal  $V_{REF} = 4.096V$ ,  $\pm 5V$  analog input range, and maximum throughput (unless otherwise noted)



### 5.9 Typical Characteristics (continued)

at  $T_A = 25^\circ\text{C}$ ,  $AVDD_{5V} = 5V$ ,  $VDD_{1V8} = 1.8V$ , internal  $V_{REF} = 4.096V$ ,  $\pm 5V$  analog input range, and maximum throughput (unless otherwise noted)

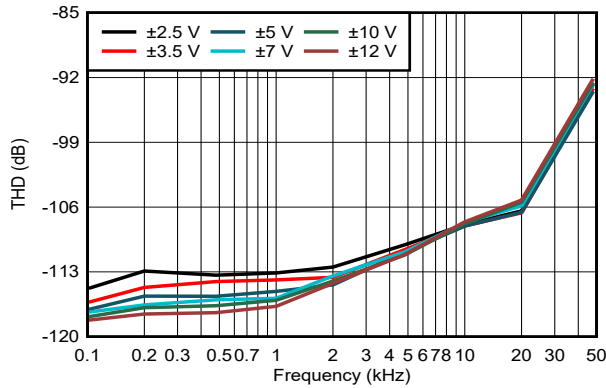

Figure 5-18. THD vs Input Signal Frequency Across Input Ranges With Low-Bandwidth LPF

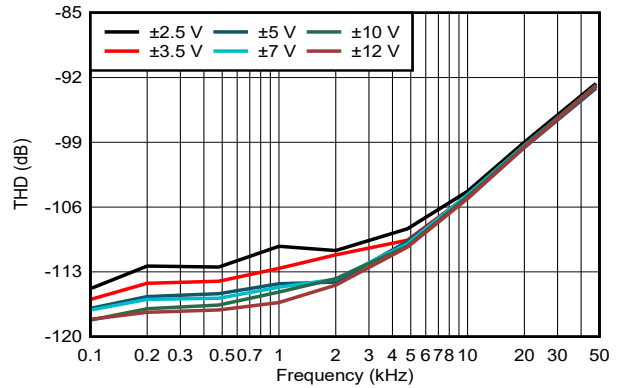

Figure 5-19. THD vs Input Signal Frequency Across Input Ranges With Wide-Bandwidth LPF

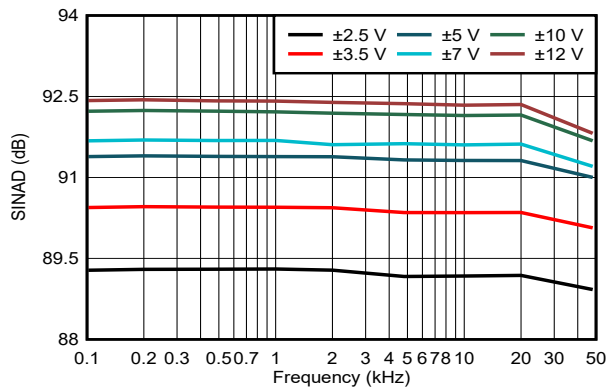

Figure 5-20. SINAD vs Input Signal Frequency Across Input Ranges With Low-Bandwidth LPF

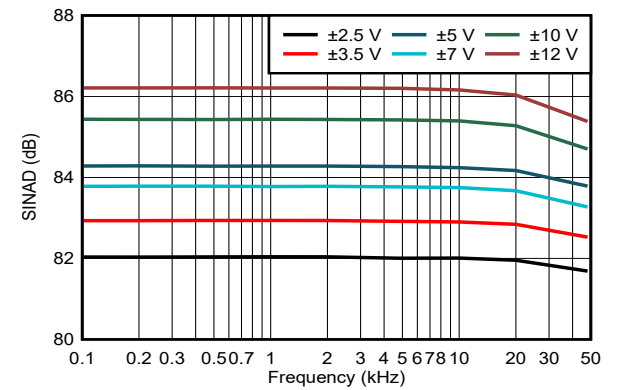

Figure 5-21. SINAD vs Input Signal Frequency Across Input Ranges With Wide-Bandwidth LPF

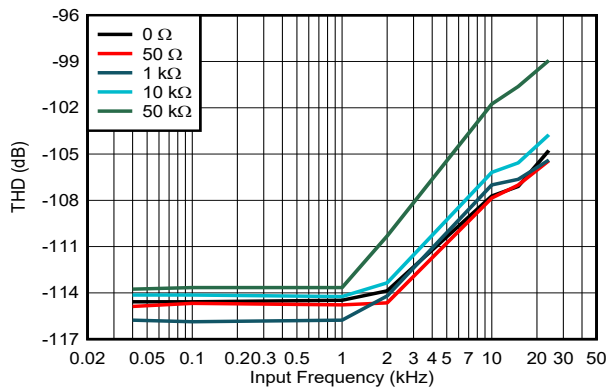

Figure 5-22. THD vs Input Frequency, Low-BW Mode, RANGE =  $\pm 5V$ , ADS9817

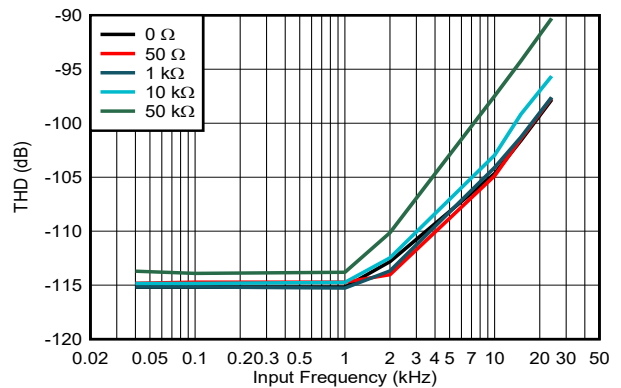
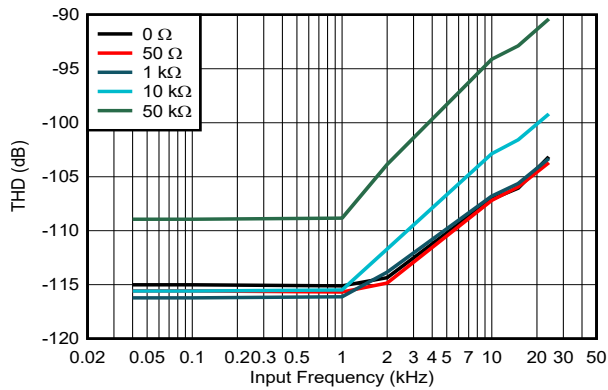

Figure 5-23. THD vs Input Frequency, High-BW Mode, RANGE =  $\pm 5V$ , ADS9817



### 5.9 Typical Characteristics (continued)

at  $T_A = 25^\circ\text{C}$ ,  $AVDD\_5V = 5V$ ,  $VDD\_1V8 = 1.8V$ , internal  $V_{REF} = 4.096V$ ,  $\pm 5V$  analog input range, and maximum throughput (unless otherwise noted)



**Figure 5-24. THD vs Input Frequency, Low-BW Mode, RANGE =  $\pm 10V$ , ADS9817**

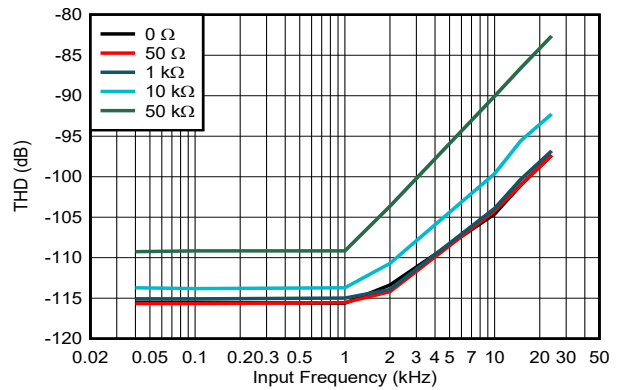

**Figure 5-25. THD vs Input Frequency, High-BW Mode, RANGE =  $\pm 10V$ , ADS9817**

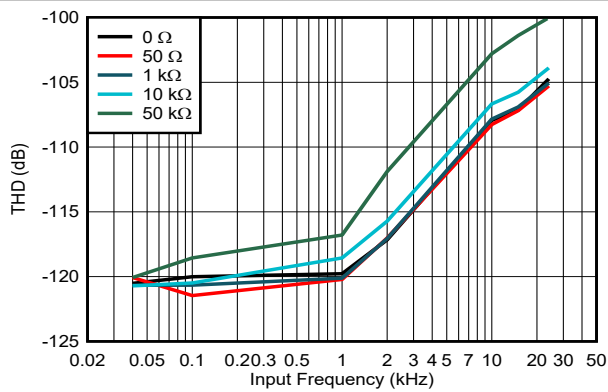

**Figure 5-26. THD vs Input Frequency, Low-BW Mode, RANGE =  $\pm 5V$ , ADS9815**

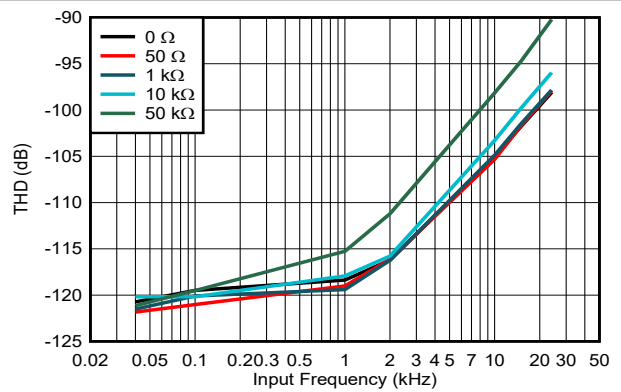

**Figure 5-27. THD vs Input Frequency, High-BW Mode, RANGE =  $\pm 5V$ , ADS9815**

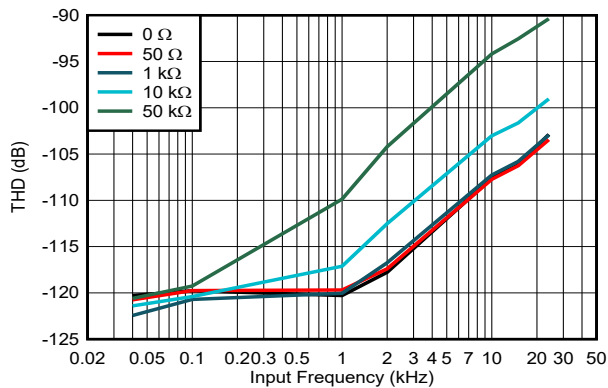

**Figure 5-28. THD vs Input Frequency, Low-BW Mode, RANGE =  $\pm 10V$ , ADS9815**

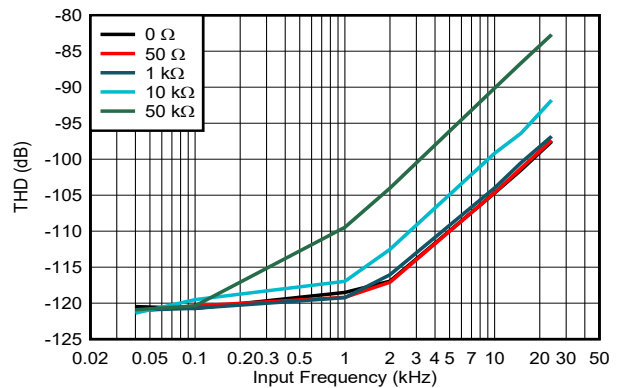

**Figure 5-29. THD vs Input Frequency, High-BW Mode, RANGE =  $\pm 10V$ , ADS9815**

### 5.9 Typical Characteristics (continued)

at  $T_A = 25^\circ\text{C}$ ,  $AVDD_{5V} = 5V$ ,  $VDD_{1V8} = 1.8V$ , internal  $V_{REF} = 4.096V$ ,  $\pm 5V$  analog input range, and maximum throughput (unless otherwise noted)

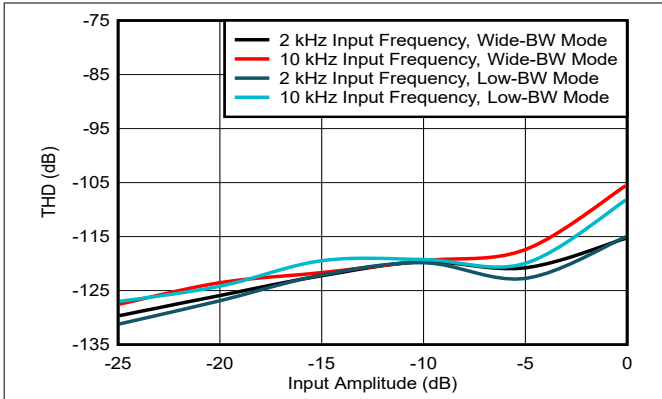

Figure 5-30. THD vs Input Amplitude, RANGE =  $\pm 5V$

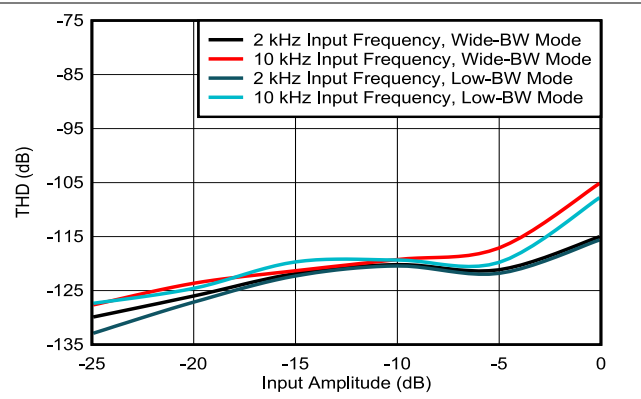

Figure 5-31. THD vs Input Amplitude, RANGE =  $\pm 10V$

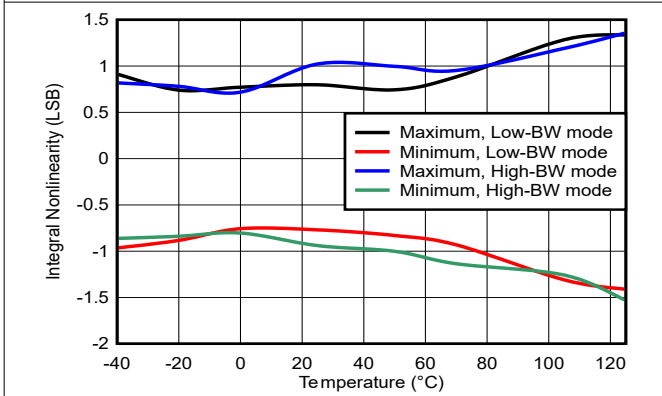

Figure 5-32. INL vs Temperature

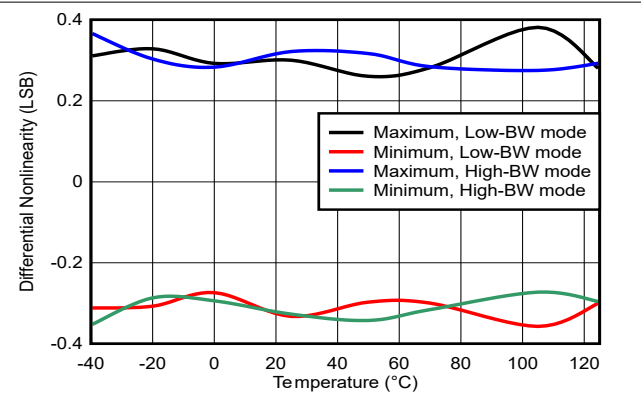

Figure 5-33. DNL vs Temperature

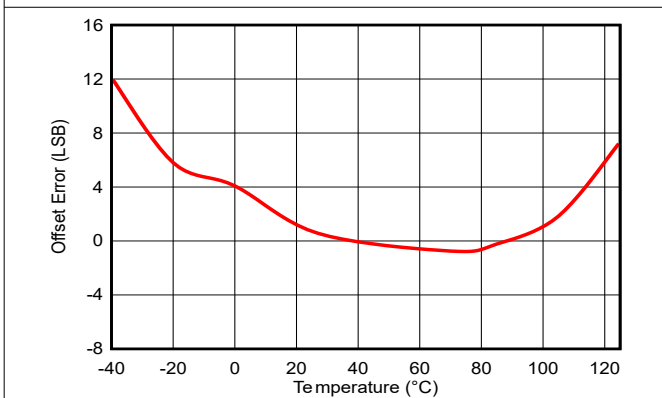

Figure 5-34. Offset Error vs Temperature, RANGE =  $\pm 5V$

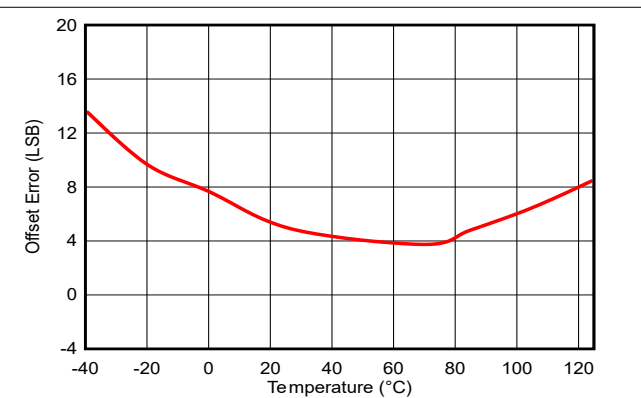

Figure 5-35. Offset Error vs Temperature, RANGE =  $\pm 10V$

### 5.9 Typical Characteristics (continued)

at  $T_A = 25^\circ\text{C}$ ,  $AVDD_{5V} = 5V$ ,  $VDD_{1V8} = 1.8V$ , internal  $V_{REF} = 4.096V$ ,  $\pm 5V$  analog input range, and maximum throughput (unless otherwise noted)

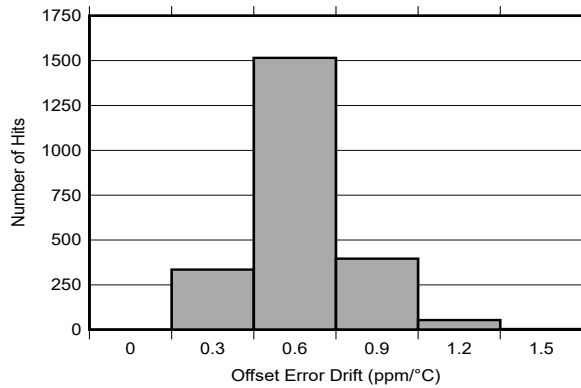

Figure 5-36. Offset Error Drift Histogram

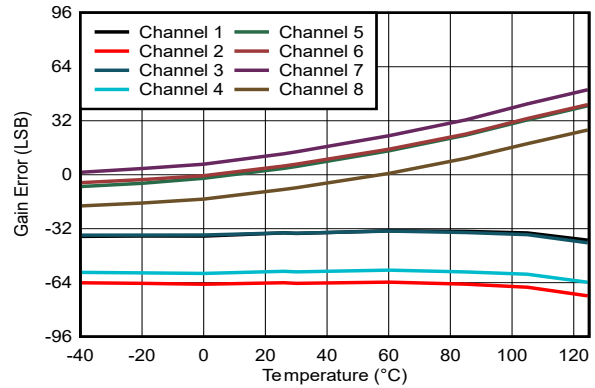

Figure 5-37. Gain Error vs Temperature, RANGE =  $\pm 5V$

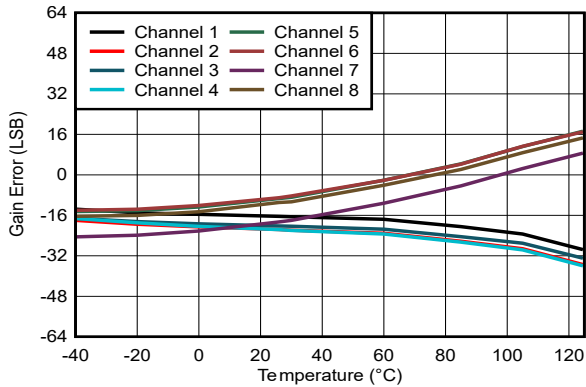

Figure 5-38. Gain Error vs Temperature, RANGE =  $\pm 10V$

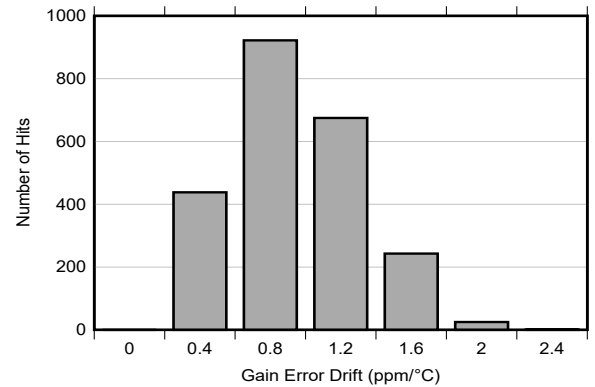
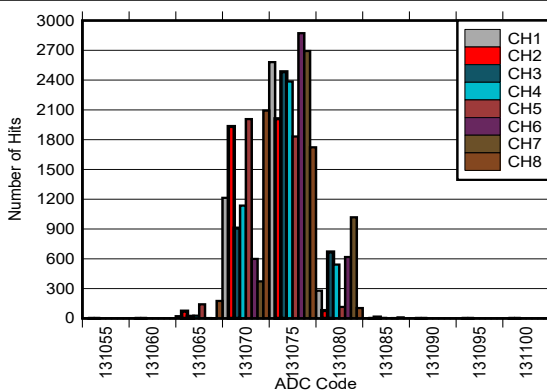
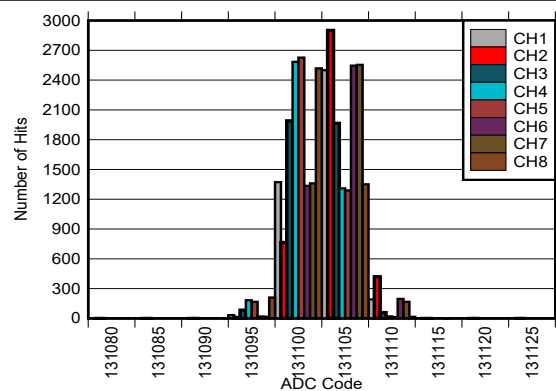

Figure 5-39. Gain Error Drift Histogram



Mean = 131073.8LSB, standard deviation = 2.45LSB, number of hits = 4096

Figure 5-40. DC Histogram of Codes for  $A_{INxP} = A_{INxM} = GND$ , Low-BW Mode, RANGE =  $\pm 5V$



Mean = 131103.5LSB, standard deviation = 2.49LSB, number of hits = 4096

Figure 5-41. DC Histogram of Codes for  $V_{IN} = 1mV$ , Low-BW Mode, RANGE =  $\pm 5V$

### 5.9 Typical Characteristics (continued)

at  $T_A = 25^\circ\text{C}$ ,  $AVDD\_5V = 5V$ ,  $VDD\_1V8 = 1.8V$ , internal  $V_{REF} = 4.096V$ ,  $\pm 5V$  analog input range, and maximum throughput (unless otherwise noted)

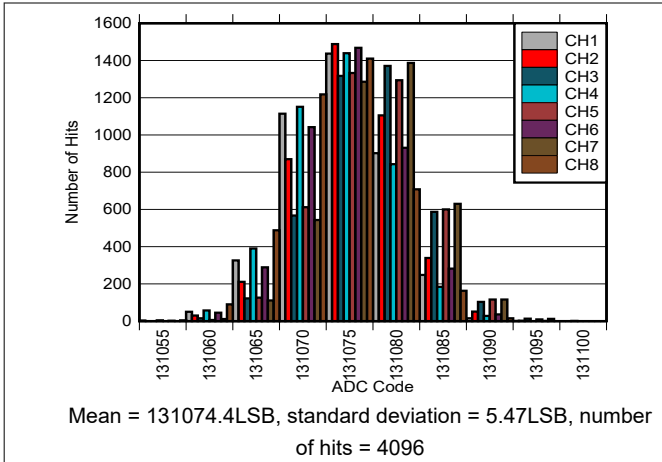

Figure 5-42. DC Histogram of Codes for  $A_{INxP} = A_{INxM} = GND$ , Wide-BW Mode, RANGE =  $\pm 5V$

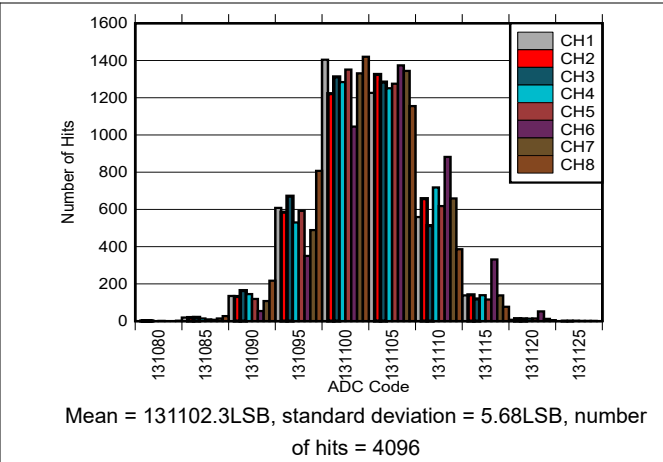

Figure 5-43. DC Histogram of Codes for  $V_{IN} = 1mV$ , Wide-BW Mode, RANGE =  $\pm 5V$

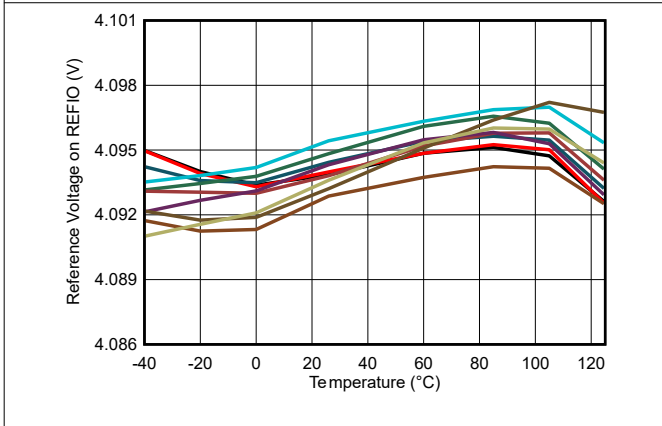

Figure 5-44. REFIO vs Temperature

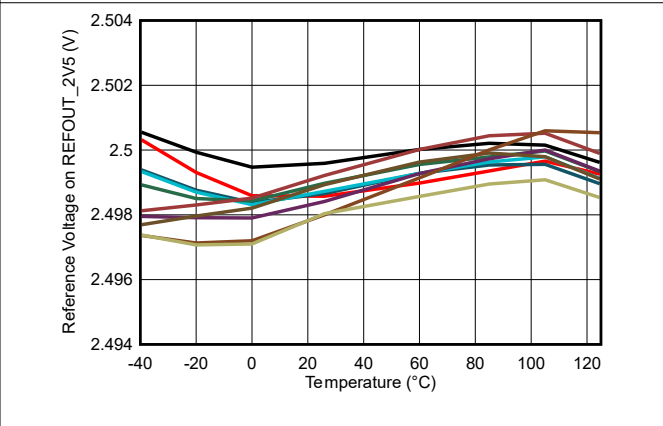

Figure 5-45. REFOUT\_2V5 vs Temperature

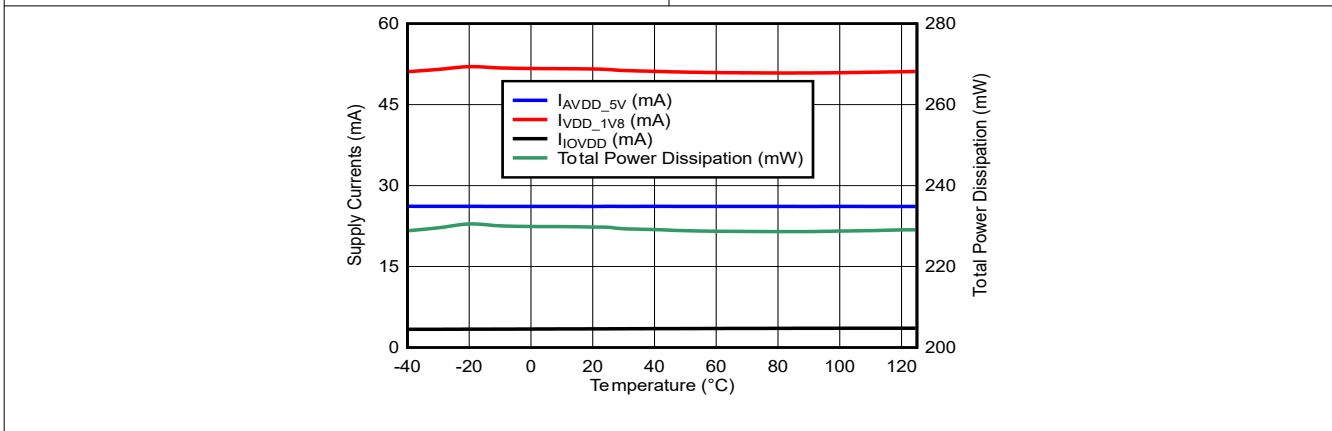

Figure 5-46. Supply Currents and Total Power Dissipation vs Temperature

## 6 Detailed Description

### 6.1 Overview

The ADS981x is an 18-bit data acquisition (DAQ) system with eight-channel analog inputs that can be configured as either single-ended or differential. Each analog input channel consists of an input clamp protection circuit, and a programmable gain amplifier (PGA) with user-selectable bandwidth options. The input signals are digitized using an 18-bit analog-to-digital converter (ADC), based on the successive approximation register (SAR) architecture. This overall system can achieve a maximum throughput of 2 MSPS/channel for all channels. The device features a 4.096V internal reference with a fast-settling buffer.

The device operates from 5V and 1.8V analog supplies and can accommodate true bipolar input signals. The input clamp protection circuitry can tolerate voltages up to  $\pm 18V$ . The device offers a constant  $1M\Omega$  resistive input impedance irrespective of the sampling frequency or the selected input range. The ADS981x offers a simplified end solution without requiring external high-voltage bipolar supplies and complicated driver circuits.

### 6.2 Functional Block Diagram

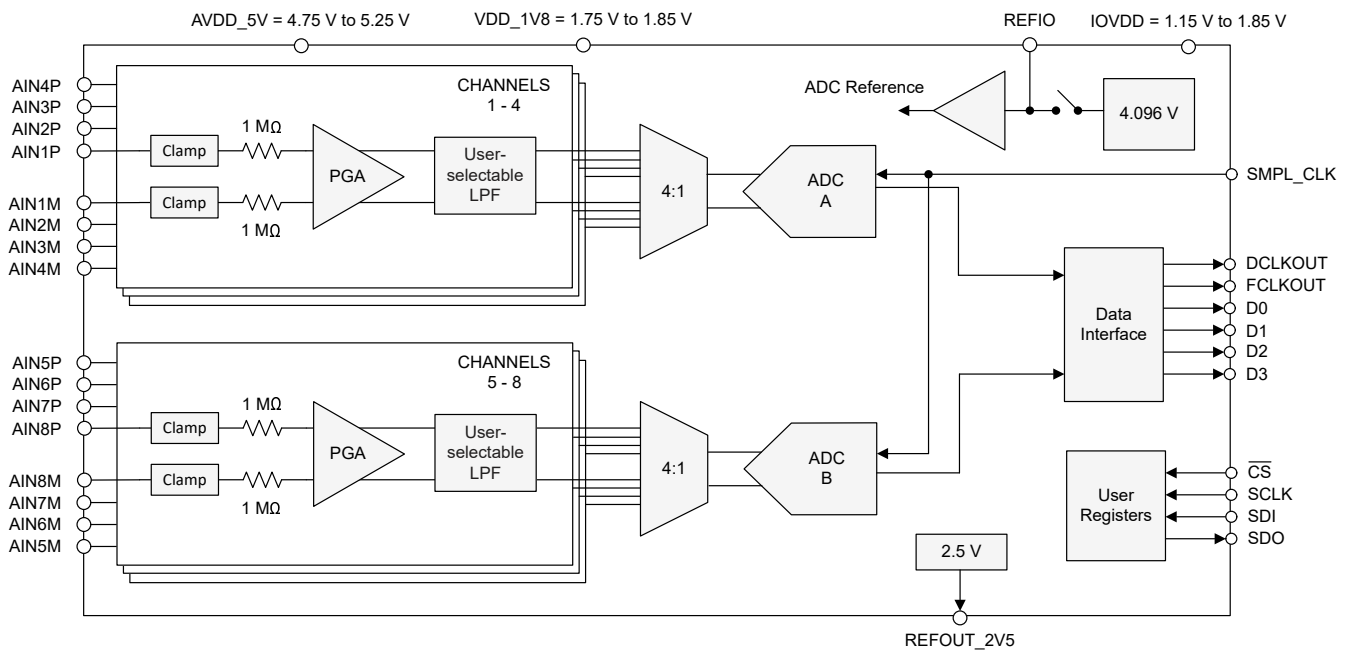

## 6.3 Feature Description

### 6.3.1 Analog Inputs

The ADS981x incorporates dual, simultaneous-sampling, 18-bit successive approximation register (SAR) analog-to-digital converters (ADCs). Each ADC is connected to four analog input channels through a multiplexer. The device has a total of eight analog input pairs. The ADC digitizes the voltage difference between the analog input pairs AINxP – AINxM. [Figure 6-1](#) shows the simplified circuit schematic for each analog input channel, including the input clamp protection circuit, PGA, low-pass filter, multiplexer, high-speed ADC driver, and a precision 18-bit SAR ADC.

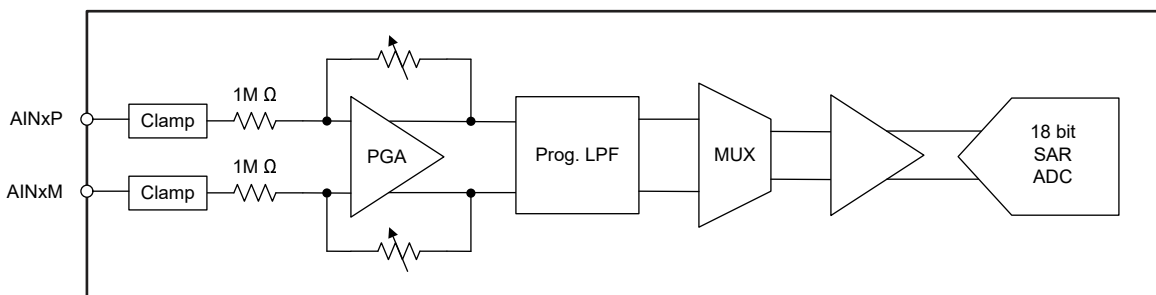
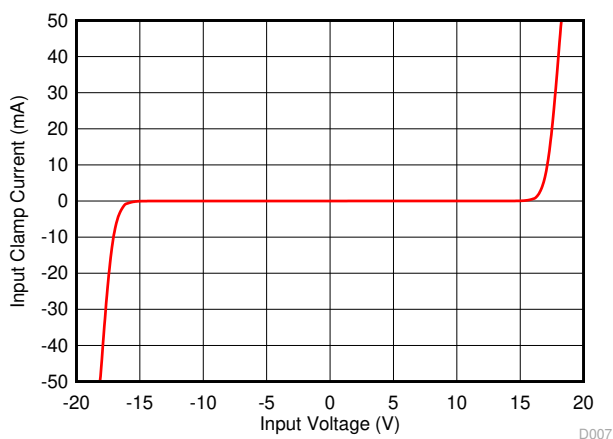

**Figure 6-1. Front-End Circuit Schematic for the Selected Analog Input Channel**

#### 6.3.1.1 Input Clamp Protection Circuit

The ADS981x features an internal clamp protection circuit on each of the eight analog input channels, see [Figure 6-1](#). The input clamp protection circuit allows each analog input to swing up to a maximum voltage of  $\pm 18V$ . Beyond an input voltage of  $\pm 18V$ , the input clamp circuit turns on and still operates from the single 5V supply. [Figure 6-2](#) shows a typical current versus voltage characteristic curve for the input clamp.

For input voltages above the clamp threshold, make sure that the input current never exceeds  $\pm 10mA$ . A resistor placed in series with the analog inputs is an effective way to limit the input current. In addition to limiting the input current, the series resistor can also provide an antialiasing, low-pass filter (LPF) when coupled with a capacitor. Matching the external source impedance on the AINxP and AINxM pins cancels any additional offset error.



**Figure 6-2. Input Protection Clamp Profile, Input Clamp Current vs Source Voltage**

#### 6.3.1.2 Programmable Gain Amplifier (PGA)

The ADS981x features a PGA at every analog input channel. The PGA supports single-ended and differential inputs with a bipolar signal swing. [Table 6-1](#) lists the supported analog input ranges. The analog input range can be configured independently for each channel by using the RANGE\_CHx register fields in address 0xC2 and address 0xC3.

**Table 6-1. Analog Input Ranges**

DIFFERENTIAL INPUTS	SINGLE-ENDED INPUTS	RANGE_CHx CONFIGURATION
±12V	±12V	5
±10V	±10V	4
±7V	±7V	3
±5V	±5V	0
±3.5V	±3.5V	1
±2.5V	±2.5V	2

Each analog input channel features an antialiasing, low-pass filter (LPF) at the output of the PGA. [Table 6-2](#) lists the various programmable LPF options available in the ADS981x corresponding to the analog input range. [Figure 5-14](#) and [Figure 5-15](#) illustrate the frequency responses for low-bandwidth and wide-bandwidth LPF configurations. The analog input bandwidth for the eight analog input channels can be selected using the ANA\_BW[7:0] bits in address 0xC0 of register bank 1.

**Table 6-2. Low-Pass Filter Corner Frequency**

LPF	ANALOG INPUT RANGE	CORNER FREQUENCY (–3dB)
Low-bandwidth	All input ranges	21kHz
Wide-bandwidth	±12V	375kHz
	±10V	385kHz
	±7V	400kHz
	±5V	320kHz
	±3.5V	240kHz
	±2.5V	182kHz

### 6.3.1.3 Wide-Common-Mode Voltage Rejection Circuit

The ADS981x features a common-mode (CM) rejection circuit at the analog inputs that supports CM voltages up to ±12V. The CM voltage for differential inputs is given by [Equation 1](#). On power-up or after reset, the common-mode voltage range for the analog input channels is ±12V (CM\_CTRL\_EN = 0b). Voltage at the analog inputs, in all cases, must be within the [Absolute Maximum Ratings](#).

$$\text{Common mode voltage} = \frac{(\text{Voltage on AINP}) + (\text{Voltage on AINM})}{2} \quad (1)$$

As described in [Table 6-3](#), the CM voltage rejection circuit can be optimized for various CM voltages for differential inputs.

**Table 6-3. Wide Common-Mode Configuration for Differential Inputs**

COMMON-MODE (CM) RANGE	CM_CTRL_EN	ADC A (ANALOG INPUT CHANNELS 1–4)		ADC B (ANALOG INPUT CHANNELS 5–8)	
		CM_EN_CH[4:1]	CM_RNG_CH[4:1]	CM_EN_CH[8:5]	CM_RNG_CH[8:5]
CM ≤ ±1V	1	0	Don't care	0	Don't care
CM ≤ ±RANGE / 2		1	0	1	0
CM ≤ ±6V			1	1	1
CM ≤ ±12V			2	2	2

The CM voltage rejection circuit must be configured depending on the analog input range of the PGA when using single-ended inputs as well. [Table 6-4](#) lists the recommended configuration for single-ended inputs for various analog input voltage ranges.

**Table 6-4. Wide Common-Mode Configuration for Single-Ended Inputs**

PGA ANALOG INPUT RANGE	CM_CTRL_EN	ADC A (ANALOG INPUT CHANNELS 1–4)		ADC B (ANALOG INPUT CHANNELS 5–8)	
		CM_EN_CH[4:1]	CM_RNG_CH[4:1]	CM_EN_CH[8:5]	CM_RNG_CH[8:5]
		±2.5V, ±3.5V, and ±5V	1	0	Don't care
±7V, ±10V, and ±12V	1	0		1	0

**6.3.1.4 Gain Error Calibration**

The ADS981x features calibration logic to minimize gain error from the analog inputs. Enable gain error calibration for minimum gain error. Gain error calibration can be enabled by configuring the GE\_CAL\_EN1 (address = 0xD), GE\_CAL\_EN2, GE\_CAL\_EN3 (address = 0x33), and GE\_CAL\_EN4 (address = 0x34).

If gain error calibration is not enabled as shown in [Table 6-5](#), the full-scale analog input ranges are increased by a factor of 1.024.

**Table 6-5. Analog Input Ranges vs Gain-Error Calibration**

RANGE_CHx CONFIGURATION	ANALOG INPUT RANGE WITH CALIBRATION	ANALOG INPUT RANGE WITHOUT CALIBRATION
5	±12V	±12.288V
4	±10V	±10.24V
3	±7V	±7.168V
0	±5V	±5.12V
1	±3.5V	±3.584V
2	±2.5V	±2.56V



### 6.3.2 ADC Transfer Function

The ADS981x outputs 18 bits of conversion data in either straight-binary or binary two's-complement formats. The format for the output codes is the same across all analog channels. The format for the output codes can be selected using the DATA\_FORMAT field in address 0xD in register bank 1. Figure 6-3 and Table 6-6 show the transfer characteristics for the ADS981x. The LSB size depends on the analog input range selected, gain-error calibration, and system gain error calibration as shown in Equation 2.

$$LSB = \frac{\text{Analog input range}}{2^{18}} \times (1 + G \times 0.024) \tag{2}$$

where:

- G is 0 when gain-error calibration is enabled, otherwise G is 1; see the [Gain Error Calibration](#) section

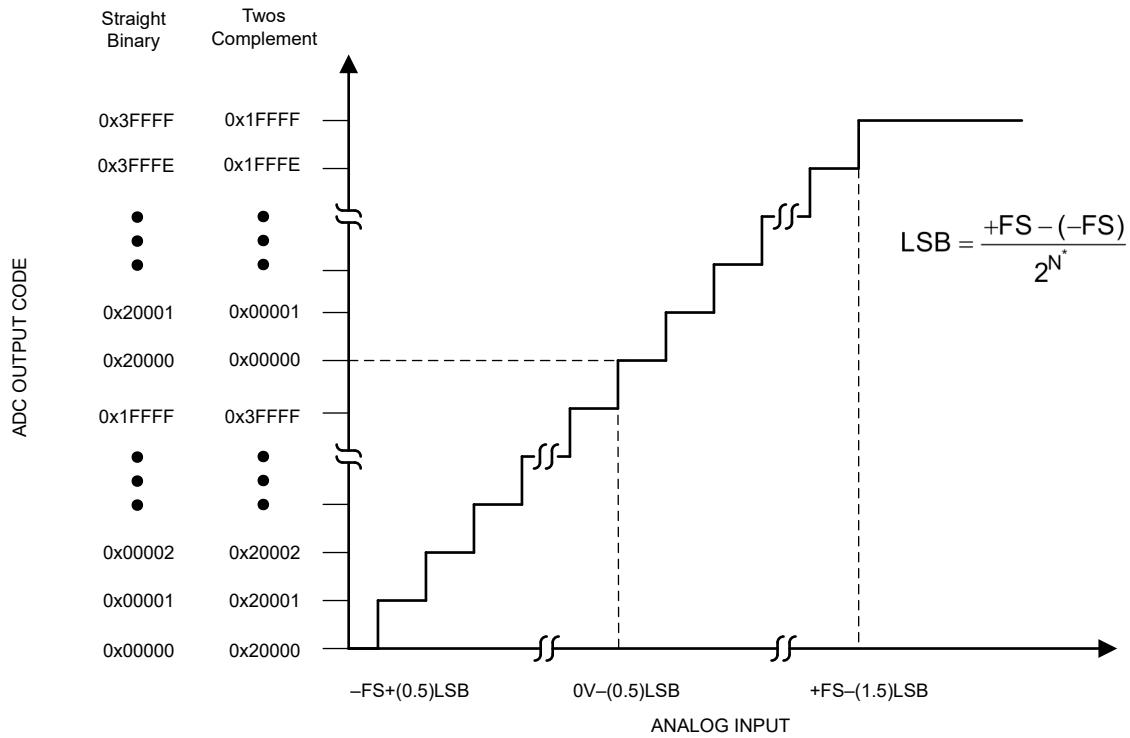

**Figure 6-3. Transfer Characteristics**

**Table 6-6. ADC Full-Scale Range and LSB Size**

RANGE	+FS	MIDSCALE	-FS	LSB
±2.5V	2.5V	0V	-2.5V	19.07µV
±3.5V	3.5V	0V	-3.5V	26.70µV
±5V	5V	0V	-5V	38.15µV
±7V	7V	0V	-7V	53.41µV
±10V	10V	0V	-10V	76.29µV
±12V	12V	0V	-12V	91.55µV

### 6.3.3 ADC Sampling Clock Input

Use a low-jitter external clock with a high slew rate to maximize SNR performance. The ADS981x can be operated with a differential or a single-ended clock input. Clock amplitude impacts the ADC aperture jitter and consequently the SNR. For maximum SNR performance, provide a clock signal with fast slew rates that maximizes swing between IOVDD and GND levels.

The sampling clock must be a free-running continuous clock. The ADC generates a valid output data, data clock, and frame clock after a free-running sampling clock is applied. The ADC is powered down and output data, data clock, and frame clock are invalid when the sampling clock is stopped.

Figure 6-4 shows a diagram of the differential sampling clock input. For this configuration, connect the differential sampling clock input to the SMPL\_CLKP and SMPL\_CLKM pins. Figure 6-5 shows a diagram of the single-ended sampling clock input. In this configuration, connect the single-ended sampling clock to SMPL\_CLKP and connect SMPL\_CLKM to ground.

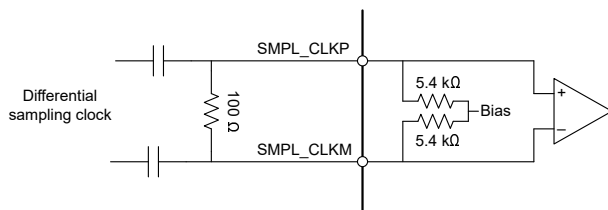

**Figure 6-4. AC-Coupled Differential Sampling Clock**

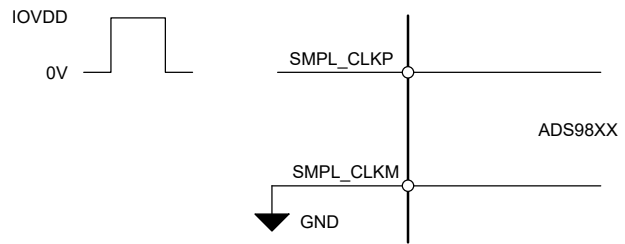

**Figure 6-5. Single-Ended Sampling Clock**

### 6.3.4 Reference

The ADS981x has a precision, low-drift voltage reference internal to the device. For best performance, filter the internal reference noise by connecting a 10 μF ceramic bypass capacitor to the REFIO pin. An external reference can also be connected at the REFIO pin and the internal reference voltage can be disabled by writing to PD\_REF = 1b in address 0xC1 of register bank 1.

#### 6.3.4.1 Internal Reference Voltage

The ADS981x features an internal reference voltage with a nominal output voltage of 4.096V. On power-up, the internal reference is enabled by default. As shown in Figure 6-6, place a minimum 10 μF decoupling capacitor between the REFIO and REFm pins.

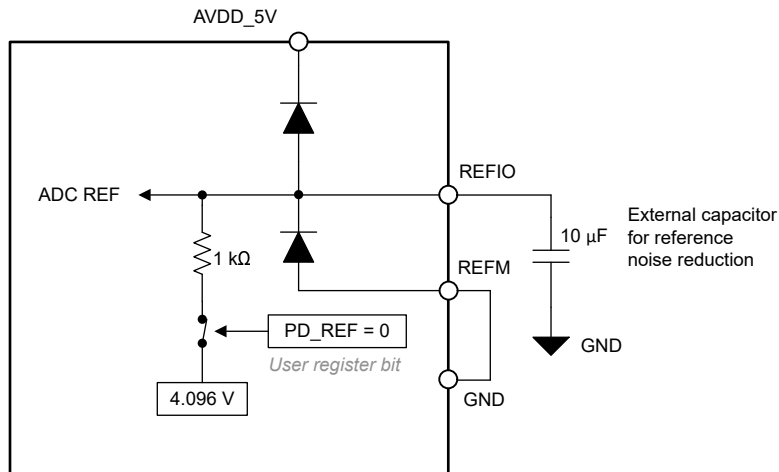

**Figure 6-6. Internal Reference Voltage**

### 6.3.4.2 External Reference Voltage

An external 4.096V reference voltage, as shown in Figure 6-7, can be connected at the REFIO pin with an appropriate decoupling capacitor placed between the REFIO and REFM pins. For improved thermal drift performance, the REF7040 is recommended. To disable the internal reference, set PD\_REF = 1b in address 0xC1 in register bank 1. The REFIO pin has ESD protection diodes connected to the AVDD\_5V and REFM pins.

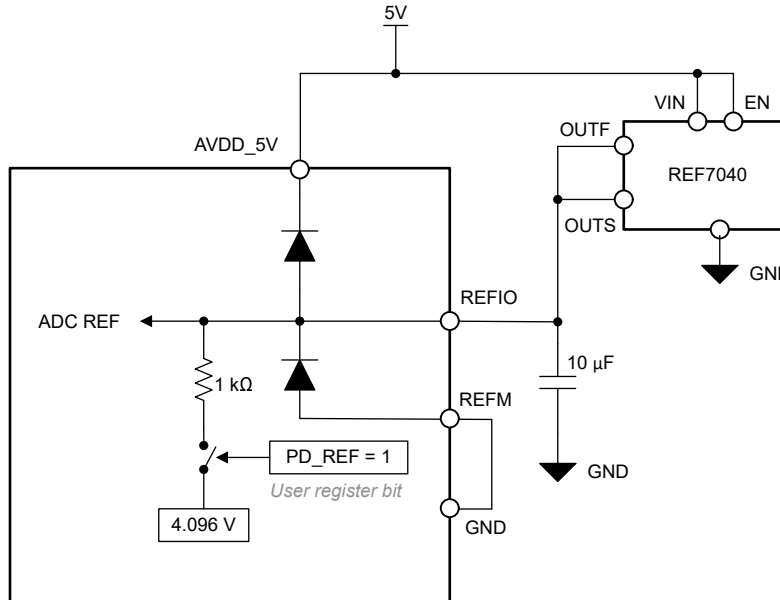

Figure 6-7. External Reference Voltage

### 6.3.5 Sample Synchronization

As illustrated in Figure 5-2, Figure 5-3, Figure 5-4, and Figure 5-5, the SMPL\_SYNC pin synchronizes multiple ADCs using an external SYNC signal. The SMPL\_SYNC pin is latched in by the falling edge of the sampling clock.

The synchronization signal is only required one time after power-up with the sampling clock free-running, or after restarting sampling clock, or after a device reset. As illustrated in Figure 5-2, Figure 5-3, Figure 5-4, and Figure 5-5, the SYNC signal resets the internal analog channel selection logic and aligns the FCLKOUT signal to the data frame. If no SYNC signal is given, the internal analog channel selection logic and FCLKOUT are not synchronized, which can lead to a different alignment between the sequence of channel output data and FCLKOUT. When using multiple ADCs with the same sampling clock, the SYNC signal makes sure all ADCs sample the same respective analog input channel at the same time.

### 6.3.6 Data Interface

The ADS981x supports 2-lane and 4-lane mode with single-data-rate (SDR) and double-data-rate (DDR) interface modes. The data interface can be selected using the configuration SPI as described in Table 6-7. The ADC generates the data (D[3:0]), data clock (DCLKOUT), and frame clock (FCLKOUT) in response to the sampling clock signal on the SMPL\_CLK input pin. The 18-bit ADC conversion result is output MSB first in a 24-bit data packet and the last six bits are zeroes.

The data interface signals can be described as:

- D[3:0]: Data output from the ADC. In 4-lane mode all four lanes are used, whereas in 2-lane mode D3 and D1 are used to output ADC data.
- DCLKOUT: Data clock output from the ADC.
- FCLKOUT: Frame clock output from the ADC delimiting each set of 8-channel data. A SYNC pulse is required on power-up or after device reset to align the rising edge of FCLKOUT with channel 1 data output, as described in the [Sample Synchronization](#) section.

Use the registers in [Table 6-7](#) to configure the data interface.

**Table 6-7. Register Configurations For Interface Modes**

INTERFACE MODE	FIGURE	DATA_RATE (Address = 0xC1)	DATA_LANES (Address = 0xC1)
4-lane, DDR	<a href="#">Figure 5-2</a>	0	0
2-lane, DDR	<a href="#">Figure 5-3</a>	0	1
4-lane, SDR	<a href="#">Figure 5-4</a>	1	0
2-lane, SDR	<a href="#">Figure 5-5</a>	1	1

**6.3.6.1 Data Clock Output**

The ADS981x features a source-synchronous data interface where the ADC provides the output data and the clock to capture the data. The clock to capture the data is output on the DCLKOUT pin. The clock frequency depends on the sampling clock speed, data rate (SDR or DDR), and number of output lanes (four lanes or two lanes) and is given by [Equation 3](#). The frame clock frequency is given by [Equation 4](#).

$$\text{Data clock frequency} = \frac{24 \text{ bits/channel} \times 8 \text{ channels}}{\text{Number of data lanes} \times \text{Data rate (SDR = 1, DDR = 2)}} \times \text{Frame clock frequency} \tag{3}$$

$$\text{Frame clock frequency} = \frac{\text{Sampling clock frequency}}{4} \tag{4}$$

[Table 6-8](#) shows the data clock frequency for the maximum sampling rates for the ADS9817 and ADS9815 for various interface modes.

**Table 6-8. Data Clock Frequency for Interface Modes**

INTERFACE MODE	ADS9815 (f <sub>SMPL_CLK</sub> = 4MHz)	ADS9817 (f <sub>SMPL_CLK</sub> = 8MHz)
4-lane, DDR	24MHz	48MHz
2-lane, DDR	48MHz	96MHz
4-lane, SDR	48MHz	96MHz
2-lane, SDR	96MHz	Not supported

**6.3.6.2 ADC Output Data Randomizer**

As shown in [Figure 6-8](#), the ADS981x features a data output randomizer. When enabled, the ADC conversion result is bit-wise exclusive-ORed (XOR) with the LSB of the conversion result. The LSB of the ADC conversion result has equal probability of being either 1 or 0. As a result of the XOR operation, the data output from the ADS981x is randomized. The ground bounce created by the transmission of this randomized result over the data interface is uncorrelated with the analog input voltage. This uncorrelated transmission helps minimize interference between data transmission and analog performance of the ADC when the PCB layout does not minimize ground bounce.

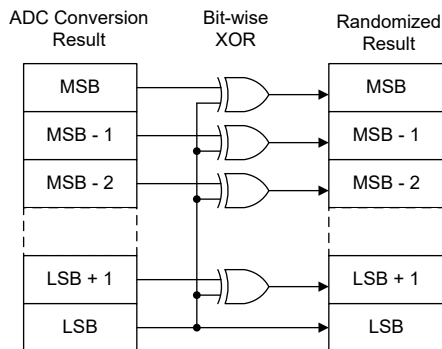
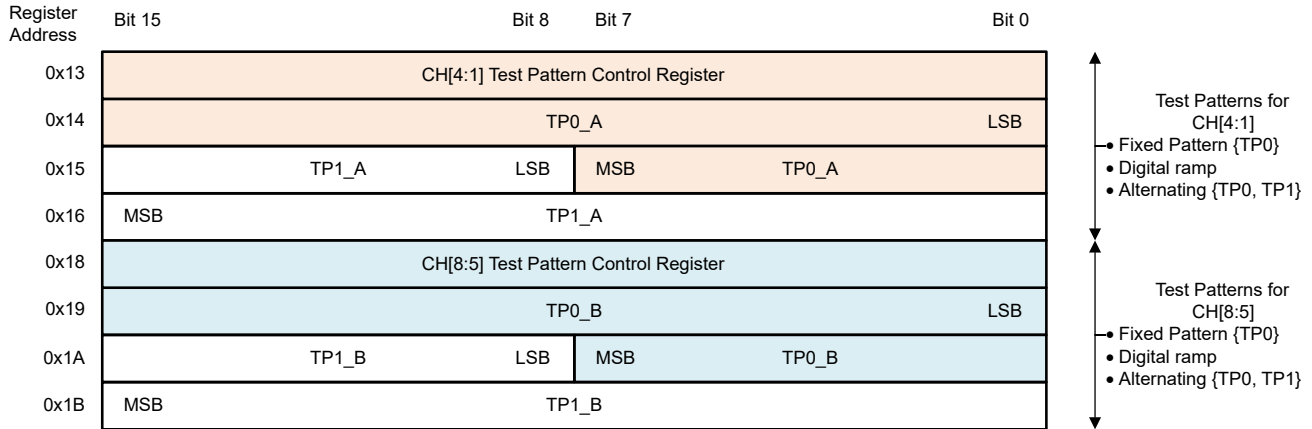

**Figure 6-8. Bit-Wise XOR Operation**

### 6.3.6.3 Test Patterns for Data Interface

As shown in Figure 6-9, the ADS981x features test patterns used by the host for debugging and verifying the data interface. The test patterns replace the ADC output data with predefined digital data. Enable the test patterns by configuring the corresponding register addresses 0x13 through 0x1B in bank 1.

Table 6-9 lists the test patterns supported by the ADS981x.



**Figure 6-9. Register Bank for Test Patterns**

**Table 6-9. Test Pattern Configurations**

ADC OUTPUT	TP_EN_CH[4:1] TP_EN_CH[8:5]	TP_MODE_CH[4:1] TP_MODE_CH[8:5]	SECTION	RESULT <sup>(1)</sup>
ADC conversion result	0			
Fixed pattern	1	0 or 1	Fixed Pattern	CH[4:1] = TP0_A CH[8:5] = TP0_B
Digital ramp	1	2	Digital Ramp	CH[4:1] = Digital ramp CH[8:5] = Digital ramp
Alternating test patterns	1	3	Alternating Test Pattern	CH[4:1] = TP0_A, TP1_A CH[8:5] = TP0_B, TP1_B

(1) Configure the test patterns for two separate channel groups CH[4:1] and CH[8:5].

#### 6.3.6.3.1 Fixed Pattern

The ADC outputs fixed patterns defined in the TP0\_A and TP0\_B registers in place of the CH[4:1] and CH[8:5] data, respectively.

- Configure the test patterns in TP0\_A and TP0\_B
- Set TP\_EN\_CH[4:1] = 1, TP\_MODE\_CH[4:1] = 0 (address = 0x13), TP\_EN\_CH[8:5] = 1, and TP\_MODE\_CH[8:5] = 0 (address = 0x18)

#### 6.3.6.3.2 Digital Ramp

The ADC outputs digital ramp values with increments specified in the RAMP\_INC\_A and RAMP\_INC\_B registers in place of the CH[4:1] and CH[8:5] data, respectively.

- Configure the increment value between two successive steps of the digital ramp in the RAMP\_INC\_A (address = 0x13) and RAMP\_INC\_B (address = 0x18) registers, respectively. The digital ramp increments by N + 1, where N is the value configured in these registers.
- Set TP\_EN\_CH[4:1] = 1, TP\_MODE\_CH[4:1] = 2 (address = 0x13), TP\_EN\_CH[8:5] = 1, and TP\_MODE\_CH[8:5] = 2 (address = 0x18)

#### 6.3.6.3.3 Alternating Test Pattern

The ADC outputs alternating test patterns defined in the TP0\_A, TP1\_A and TP0\_B, TP1\_B registers in place of the CH[4:1] and CH[8:5] data, respectively.

- Configure the test patterns in TP0\_A, TP1\_A, TP0\_B, and TP1\_B
- Set TP\_EN\_CH[4:1] = 1, TP\_MODE\_CH[4:1] = 3 (address = 0x13), TP\_EN\_CH[8:5] = 1, and TP\_MODE\_CH[8:5] = 3 (address = 0x18)

## 6.4 Device Functional Modes

### 6.4.1 Power-Down

The ADS981x is powered-down by either a logic 0 on the  $\overline{\text{PWDN}}$  pin or by writing 11b to the PD\_CH field in address 0xC0 in register bank 1. The device registers settings are retained.

### 6.4.2 Reset

The ADS981x is powered down and reset by either a logic 0 on the  $\overline{\text{RESET}}$  pin or by writing 1b to the RESET field in address 0x00 in register bank 0. The device registers are initialized to the default values after reset and the device must be initialized with a sequence of register write operations; see the [Initialization Sequence](#) section.

### 6.4.3 Initialization Sequence

As shown in [Table 6-10](#), the ADS981x must be initialized by a sequence of register writes after device power-up or reset. A free-running sampling clock must be connected to the ADC before executing the initialization sequence. The ADS981x registers are initialized with the default value after the initialization sequence is complete.

**Table 6-10.**  
**ADS981x**  
**Initialization**  
**Sequence**

STEP NUMBER	REGISTER			COMMENT
	BANK	ADDRESS	VALUE[15:0]	
STEP NUMBER	REGISTER			COMMENT
	BANK	ADDRESS	VALUE[15:0]	
1	0	0x03	0x0002	Select register bank 1
2	1	0xF6	0x0002	INIT_2 = 1
3	0	0x04	0x000B	INIT_1 = 1011b
4	0	0x03	0x0010	Select register bank 2
5	2	0x12	0x0040	INIT_3 = 1
6	2	0x13	0x8000	INIT_4 = 1
7	2	0x0A	0x4000	INIT_5 = 1
8	Wait 10 $\mu$ s (min)			
9	2	0x0A	0x0000	INIT_5 = 0
10	0	0x03	0x0002	Select register bank 1
11	1	0xF6	0x0000	INIT_2 = 0
12	0	0x03	0x0010	Select register bank 2
13	2	0x13	0x0000	INIT_5 = 0
14	2	0x12	0x0000	INIT_4 = 0
15	0	0x04	0x0000	INIT_1 = 0
16	0	0x03	0x0002	Select register bank 1
17	1	0x33	0x0030	Write INIT_KEY
18	1	0xF4	0x0000	INIT = 0
19	1	0xF4	0x0002	INIT = 1
20	Wait 1 ms (min)			
21	1	0xF4	0x0000	INIT = 0
22	Wait 1 ms (min)			
23	1	0x33	0x0000	INIT_KEY = 0
24	1	0x0D	<user-defined>	Enable gain error calibration and select ADC output data format

**Table 6-10.  
ADS981x  
Initialization  
Sequence  
(continued)**

STEP NUMBER	REGISTER			COMMENT
	BANK	ADDRESS	VALUE[15:0]	
25	1	0x33	0x2040	Enable gain error calibration
26	1	0x34	0x0010	Enable gain error calibration

**Table 6-10.  
ADS981x  
Initialization  
Sequence**

STEP NUMBER	REGISTER			COMMENT
	BANK	ADDRESS	VALUE[15:0]	
1	0	0x03	0x0002	Select register bank 1
2	1	0xF6	0x0002	INIT_2 = 1
3	0	0x04	0x000B	INIT_1 = 1011b
4	0	0x03	0x0010	Select register bank 2
5	2	0x12	0x0040	INIT_3 = 1
6	2	0x13	0x8000	INIT_4 = 1
7	2	0x0A	0x4000	INIT_5 = 1
8	Wait 10 μs (min)			
9	2	0x0A	0x0000	INIT_5 = 0
10	0	0x03	0x0002	Select register bank 1
11	1	0xF6	0x0000	INIT_2 = 0
12	0	0x03	0x0010	Select register bank 2
13	2	0x13	0x0000	INIT_5 = 0
14	2	0x12	0x0000	INIT_4 = 0
15	2	0x19	0x0E00	INIT_4A = 111b
16	2	0x1F	0x1800	INIT_5A = 11b
17	0	0x04	0x0000	INIT_1 = 0
18	0	0x03	0x0002	Select register bank 1
19	1	0x33	0x0030	Write INIT_KEY
20	1	0xF4	0x0000	INIT = 0
21	1	0xF4	0x0002	INIT = 1
22	Wait 1 ms (min)			
23	1	0xF4	0x0000	INIT = 0
24	Wait 1 ms (min)			
25	1	0x33	0x0000	INIT_KEY = 0
26	1	0x0D	<user-defined>	Enable gain error calibration and select ADC output data format
27	1	0x33	0x2040	Enable gain error calibration
28	1	0x34	0x0010	Enable gain error calibration



**Table 6-10.  
ADS981x  
Initialization  
Sequence  
(continued)**

STEP NUMBER	REGISTER			COMMENT
	BANK	ADDRESS	VALUE[15:0]	
STEP NUMBER	REGISTER			COMMENT
	BANK	ADDRESS	VALUE[15:0]	
29	1	0x37	0x0005	Device initialized

As shown in [Table 6-11](#), the default settings of the ADS981x can be changed for user-defined configuration:

- Analog inputs: analog input range, bandwidth, and common-mode voltage range
- Data interface: number of output lanes, single or double data rate

**Table 6-11. ADS981x User-Configuration**

STEP	REGISTER			COMMENT
	BANK	ADDRESS	VALUE[15:0]	
1	1	0xC1	<user-defined>	Configure data interface (data rate, number of lanes) and select internal or external reference
2	1	0xC2 and 0xC3	<user-defined>	Select analog input ranges. See <a href="#">Table 6-1</a>
3	1	0xC0	<user-defined>	Select analog input bandwidth. See <a href="#">Table 6-2</a>
4	1	0xC4 and 0xC5	<user-defined>	Select common-mode range for analog inputs. See <a href="#">Table 6-3</a> and <a href="#">Table 6-4</a>

#### 6.4.4 Normal Operation

After the ADS981x is initialized (see [Table 6-10](#)), the ADS981x converts analog input voltages to digital output. A free-running sampling clock is required for normal device operation; see the [ADC Sampling Clock Input](#) section.

### 6.5 Programming

#### 6.5.1 Register Write

Register write access is enabled by setting SPI\_RD\_EN = 0b. The 16-bit configuration registers are grouped in three register banks and are addressable with an 8-bit register address. Register bank 1 and register bank 2 are selected for read or write operation by configuring the REG\_BANK\_SEL bits. Registers in bank 0 are always accessible, irrespective of the REG\_BANK\_SEL bits. The register addresses in bank 0 are unique and are not used in register banks 1 and 2.

As shown in [Figure 6-10](#), steps to write to a register are:

1. Frame 1: Write to register address 0x03 in register bank 0 to select either register bank 1 or bank 2 for a subsequent register write. This frame has no effect when writing to registers in bank 0.
2. Frame 2: Write to a register in the bank selected in frame 1. Repeat this step for writing to multiple registers in the same register bank.

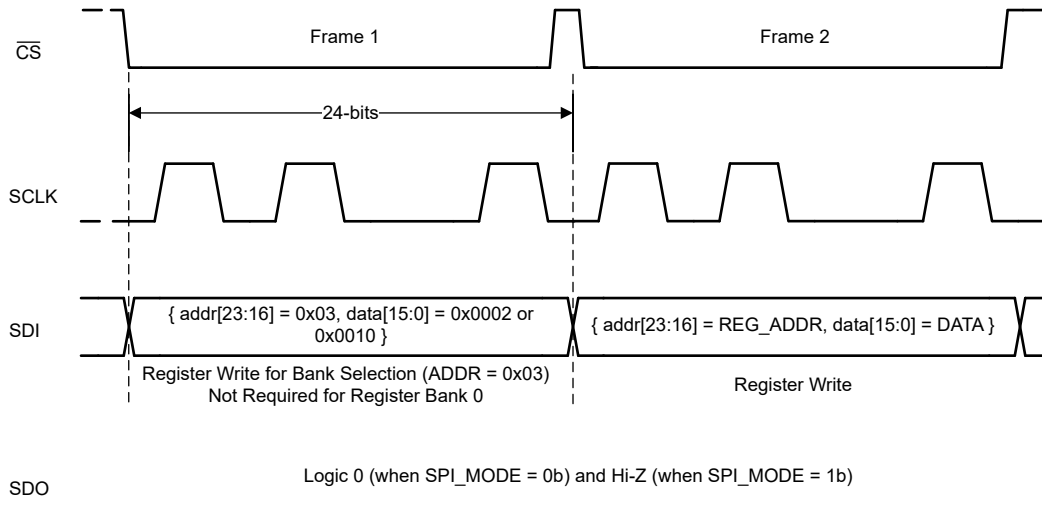

Figure 6-10. Register Write

### 6.5.2 Register Read

Select the desired register bank by writing to register address 0x03 in register bank 0. Register read access is enabled by setting SPI\_RD\_EN = 1b and SPI\_MODE = 1b in register bank 0. As illustrated in Figure 6-11, registers are read using two 24-bit SPI frames after SPI\_RD\_EN and SPI\_MODE are set. The first SPI frame selects the register bank. The ADC returns the 16-bit register value in the second SPI frame corresponding to the 8-bit register address.

As illustrated in Figure 6-11, steps to read a register are:

1. Frame 1: With SPI\_RD\_EN = 0b, write to register address 0x03 in register bank 0 to select the desired register bank for reading.
2. Frame 2: Set SPI\_RD\_EN = 1b and SPI\_MODE = 1b in register address 0x00 in register bank 0.
3. Frame 3: Read any register in the selected bank using a 24-bit SPI frame containing the desired register address. Repeat this step with the address of any register in the selected bank to read the corresponding register.
4. Frame 4: Set SPI\_RD\_EN = 0 to disable register reads and re-enable register writes.
5. Repeat steps 1 through 4 to read registers in a different bank.

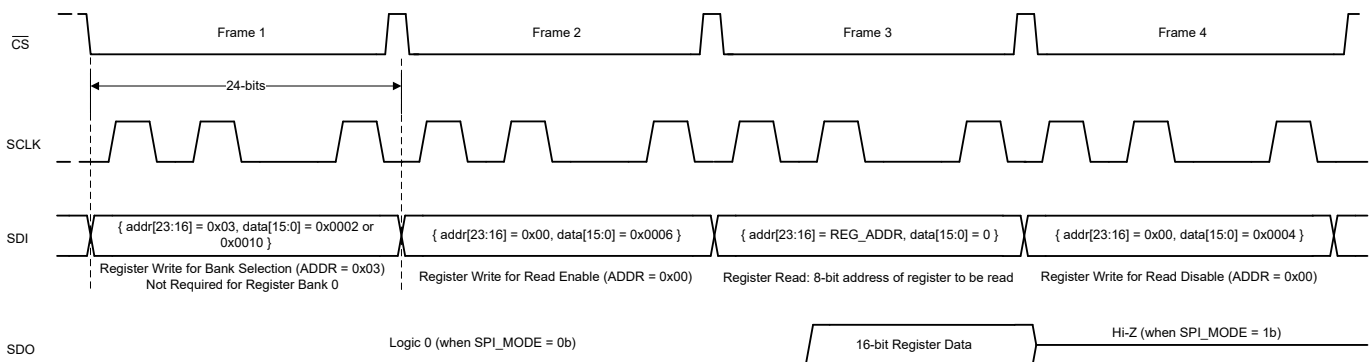
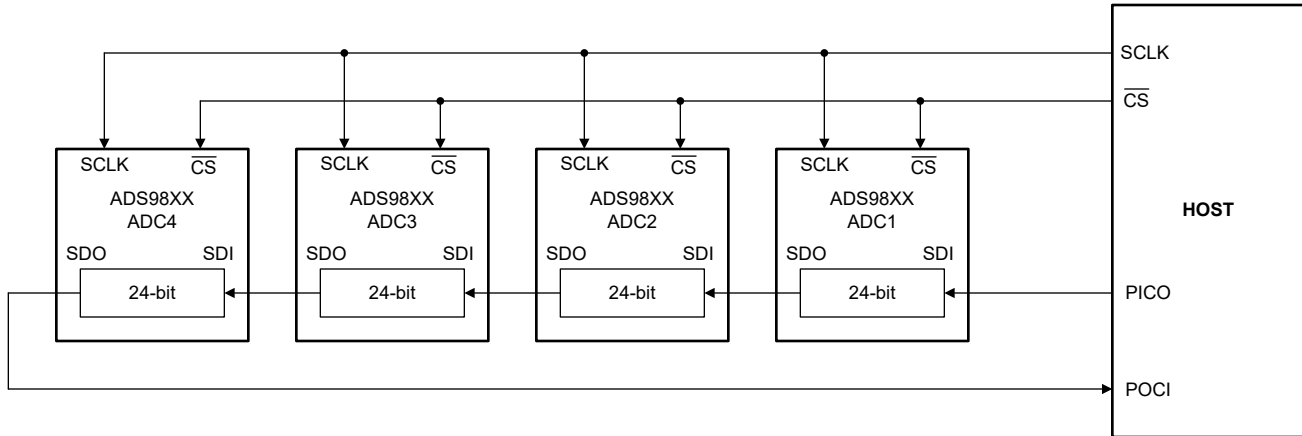

Figure 6-11. Register Read

### 6.5.3 Multiple Devices: Daisy-Chain Topology for SPI Configuration

Figure 6-12 shows a typical connection diagram showing multiple devices in a daisy-chain topology.



**Figure 6-12. Daisy-Chain Connections for SPI Configuration**

The  $\overline{CS}$  and SCLK inputs of all ADCs are connected together and controlled by a single  $\overline{CS}$  and SCLK pin of the controller, respectively. The SDI input pin of the first ADC in the chain (ADC1) is connected to the peripheral IN controller OUT (PICO) pin of the controller, the SDO output pin of ADC1 is connected to the SDI input pin of ADC2, and so on. The SDO output pin of the last ADC in the chain (ADC4) is connected to the peripheral OUT controller IN (POCI) pin of the controller. The data on the PICO pin passes through ADC1 with a 24-SCLK delay, as long as  $\overline{CS}$  is active.

The daisy-chain mode must be enabled after power-up or after the device is reset. Set the daisy-chain length in the DAISY\_CHAIN\_LEN register to enable daisy-chain mode. The daisy-chain length is the number of ADCs in the chain excluding ADC1. In Figure 6-12, the DAISY\_CHAIN\_LEN = 3.

### 6.5.3.1 Register Write With Daisy-Chain

Writing to registers in a daisy-chain configuration requires  $N \times 24$ -SCLKs in one SPI frame. A register write in a daisy-chain containing four ADCs, as shown in Figure 6-13, requires 96 SCLKs.

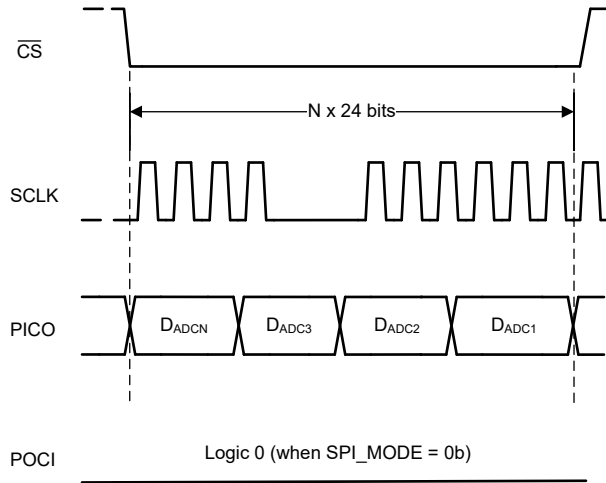

**Figure 6-13. Register Write With Daisy-Chain**

Daisy-chain mode is enabled on power-up or after device reset. Configure the DAISY\_CHAIN\_LEN field to enable daisy-chain mode. The waveform shown in Figure 6-13 must be repeated  $N$  times, where  $N$  is the number of ADCs in the daisy-chain. Figure 6-14 provides the SPI waveform, containing  $N$  SPI frames, for enabling daisy-chain mode for  $N$  ADCs.

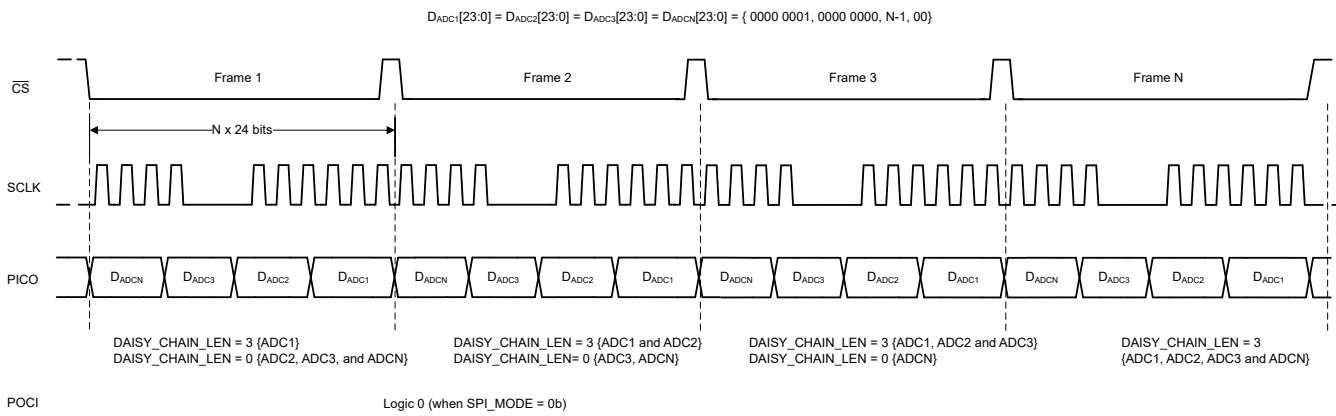

**Figure 6-14. Register Write to Configure Daisy-Chain Length**

### 6.5.3.2 Register Read With Daisy-Chain

Figure 6-15 illustrates an SPI waveform for reading registers in a daisy-chain configuration. The steps for reading registers from  $N$  ADCs connected in a daisy-chain are as follows:

1. Register read is enabled by writing to the following registers using the [Register Write With Daisy-Chain](#):
  - a. Write to PAGE\_SEL to select the desired register bank
  - b. Enable register read by writing SPI\_RD\_EN = 0b and SPI\_MODE = 0b (default on power-up)
2. With the register bank selected, the controller can read register data in the following two steps:
  - a.  $N \times 24$ -bit SPI frame containing the 8-bit register address to be read:  $N$ -times {0xFE, 0x00, 8-bit register address}
  - b.  $N \times 24$ -bit SPI frame to read out register data:  $N$ -times {0xFF, 0xFF, 0xFF}

The 0xFE in step 2a configures the ADC for register read from the specified 8-bit address. At the end of step 2a, the output shift register in the ADC is loaded with register data. The ADC returns the 8-bit register address and corresponding 16-bit register data in step 2b.

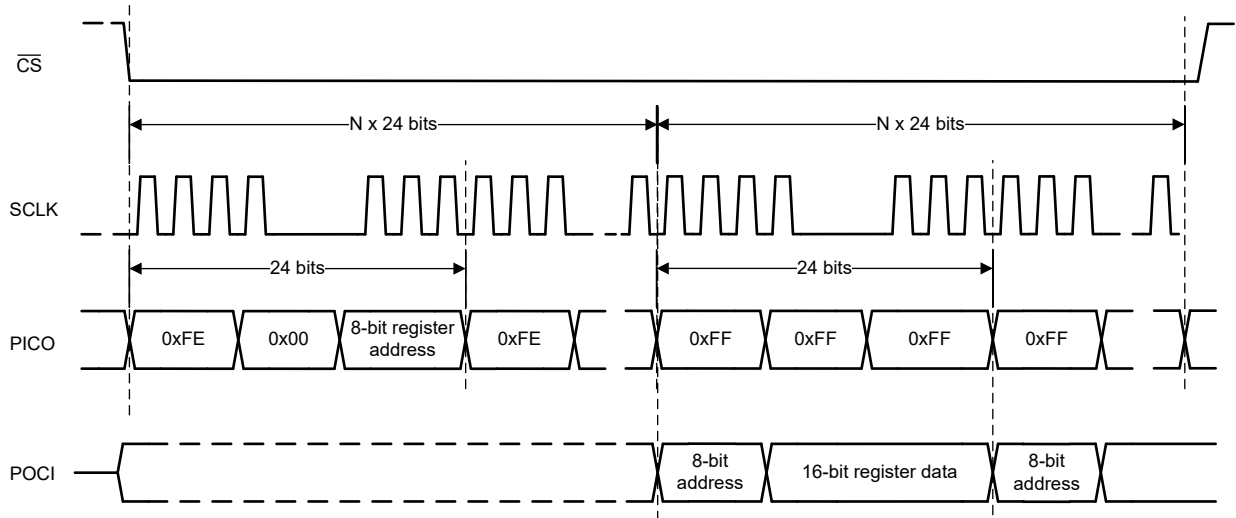

**Figure 6-15. Register Read With Daisy-Chain**

## 7 Register Map

### 7.1 Register Bank 0

**Figure 7-1. Register Bank 0 Map**

ADD	D15	D14	D13	D12	D11	D10	D9	D8	D7	D6	D5	D4	D3	D2	D1	D0
00h	RESERVED													SPI_MO DE	SPI_RD _EN	RESET
01h	RESERVED								DAISY_CHAIN_LEN				RESERVED			
03h	RESERVED							REG_BANK_SEL								
04h	RESERVED											INIT_1				
06h	REG_00H_READBACK															

**Table 7-1. Register Section/Block Access Type Codes**

Access Type	Code	Description
R	R	Read
W	W	Write
R/W	R/W	Read or write
Reset or Default Value		
-n		Value after reset or the default value

#### 7.1.1 Register 00h (offset = 0h) [reset = 0h]

**Figure 7-2. Register 00h**

15	14	13	12	11	10	9	8
RESERVED							
W-0h							
7	6	5	4	3	2	1	0
RESERVED					SPI_MODE	SPI_RD_EN	RESET
W-0h					W-0h	W-0h	W-0h

**Figure 7-3. Register 00h Field Descriptions**

Bit	Field	Type	Reset	Description
15-3	RESERVED	W	0h	Reserved. Do not change from the default reset value.
2	SPI_MODE	W	0h	Select between legacy SPI mode and daisy-chain SPI mode for the configuration interface for register access. 0 : Daisy-chain SPI mode 1 : Legacy SPI mode
1	SPI_RD_EN	W	0h	Enable register read access in legacy SPI mode. This bit has no effect in daisy-chain SPI mode. 0 : Register read disabled 1 : Register read enabled
0	RESET	W	0h	ADC reset control. 0 : Normal device operation 1 : Reset ADC and all registers

### 7.1.2 Register 01h (offset = 1h) [reset = 0h]

Figure 7-4. Register 01h

15	14	13	12	11	10	9	8
RESERVED							
R/W-0h							
7	6	5	4	3	2	1	0
RESERVED	DAISY_CHAIN_LEN					RESERVED	
R/W-0h	R/W-0h					R/W-0h	

Figure 7-5. Register 01h Field Descriptions

Bit	Field	Type	Reset	Description
15-7	RESERVED	R/W	0h	Reserved. Do not change from the default reset value.
6-2	DAISY_CHAIN_LEN	R/W	0h	Configure the number of ADCs connected in daisy-chain for the SPI configuration. 0 : 1 ADC 1 : 2 ADCs 31 : 32 ADCs
1-0	RESERVED	R/W	0h	Reserved. Do not change from the default reset value.

### 7.1.3 Register 03h (offset = 3h) [reset = 2h]

Figure 7-6. Register 03h

15	14	13	12	11	10	9	8
RESERVED							
R/W-0h							
7	6	5	4	3	2	1	0
REG_BANK_SEL							
R/W-2h							

Figure 7-7. Register 03h Field Descriptions

Bit	Field	Type	Reset	Description
15-8	RESERVED	R/W	0h	Reserved. Do not change from the default reset value.
7-0	REG_BANK_SEL	R/W	2h	Register bank selection for read and write operations. 0 : Select register bank 0 2 : Select register bank 1 16 : Select register bank 2



### 7.1.4 Register 04h (offset = 4h) [reset = 0h]

**Figure 7-8. Register 04h**

15	14	13	12	11	10	9	8
RESERVED							
R-0h							
7	6	5	4	3	2	1	0
RESERVED				INIT_1			
R/W-0h							

**Figure 7-9. Register 04h Field Descriptions**

Bit	Field	Type	Reset	Description
3-0	INIT_1	R/W	0h	INIT_1 field for device initialization. Write 1011b during the initialization sequence. Write 0000b for normal operation.

### 7.1.5 Register 06h (offset = 6h) [reset = 2h]

**Figure 7-10. Register 06h**

15	14	13	12	11	10	9	8
REG_00H_READBACK							
R-0h							
7	6	5	4	3	2	1	0
REG_00H_READBACK							
R-5h							

**Figure 7-11. Register 06h Field Descriptions**

Bit	Field	Type	Reset	Description
15-0	REG_00H_READ BACK	R	2h	This register is a copy of the register address 0x00 for readback. The register address 0x00 is write-only. The default readback value is 2h because SPI_RD_EN in address 0x00 must be set to 1 for register reads.

## 7.2 Register Bank 1

**Figure 7-12. Register Bank 1 Map**

ADD	D15	D14	D13	D12	D11	D10	D9	D8	D7	D6	D5	D4	D3	D2	D1	D0	
0Dh	RESERVED		DATA_FORMAT	RESERVED				GE_CAL_EN1		RESERVED							
12h	RESERVED												XOR_EN	RESERVED			
13h	RESERVED							RAMP_INC_A			TP_MODE_CH[4:1]		TP_EN_CH[4:1]	RESERVED			
14h	TP0_A																
15h	TP1_A								TP0_A								
16h	TP1_A																
18h	RESERVED							RAMP_INC_B			TP_MODE_CH[8:5]		TP_EN_CH[8:5]	RESERVED			
19h	TP0_B																
1Ah	TP1_B								TP0_B								
1Bh	TP1_B																
1Ch	RESERVED		USER_BITS_CH[8:5]					RESERVED		USER_BITS_CH[4:1]							
33h	RESERVED		GE_CAL_EN3	RESERVED					GE_CAL_EN2	INIT_KEY		RESERVED					
34h	RESERVED											GE_CAL_EN4	RESERVED				
C0h	RESERVED							ANA_BW						PD_CH			
C1h	RESERVED				PD_REF	RESERVED	DATA_LANES	DATA_RATE	RESERVED								
C2h	RANGE_CH4				RANGE_CH3				RANGE_CH2				RANGE_CH1				
C3h	RANGE_CH8				RANGE_CH7				RANGE_CH6				RANGE_CH5				
C4h	RESERVED						CM_RNG_CH[8:5]		CM_RNG_CH[4:1]		RESERVED		CM_EN_CH[8:5]	CM_EN_CH[4:1]	RESERVED	PD_CHIP	
C5h	RESERVED											CM_CTL_EN	RESERVED				
F4h	RESERVED														INIT	RESERVED	
F6h	RESERVED														INIT_2	RESERVED	

**Table 7-2. Register Section/Block Access Type Codes**

Access Type	Code	Description
R	R	Read
W	W	Write
R/W	R/W	Read or write
Reset or Default Value		
-n		Value after reset or the default value

### 7.2.1 Register 0Dh (offset = Dh) [reset = 2002h]

**Figure 7-13. Register 0Dh**

15	14	13	12	11	10	9	8
RESERVED		DATA_FORMAT	RESERVED				GE_CAL_EN1
R/W-0h		R/W-1h	R/W-0h				R/W-0h
7	6	5	4	3	2	1	0
GE_CAL_EN1	RESERVED						
R/W-0h	R/W-2h						

**Figure 7-14. Register 0Dh Field Descriptions**

Bit	Field	Type	Reset	Description
15-14	RESERVED	R/W	0h	Reserved. Do not change from the default reset value.
13	DATA_FORMAT	R/W	1h	Select data format for the ADC conversion result. 0 : Straight binary format 1 : Two's-complement format
12-9	RESERVED	R/W	0h	Reserved. Do not change from the default reset value.
8-7	GE_CAL_EN1	R/W	0h	Global control for gain error calibration. 0 : Gain error calibration disabled for all channels 3 : Gain error calibration enabled for all channels
6-0	RESERVED	R/W	2h	Reserved. Do not change from the default reset value.

### 7.2.2 Register 12h (offset = 12h) [reset = 2h]

**Figure 7-15. Register 12h**

15	14	13	12	11	10	9	8
RESERVED							
R/W-0h							
7	6	5	4	3	2	1	0
RESERVED				XOR_EN	RESERVED		
R/W-0h				R/W-0h	R/W-2h		

**Figure 7-16. Register 12h Field Descriptions**

Bit	Field	Type	Reset	Description
15-4	RESERVED	R/W	0h	Reserved. Do not change from the default reset value.
3	XOR_EN	R/W	0h	Enables XOR operation on ADC conversion result. 0 : XOR operation is disabled 1 : ADC conversion result is bit-wise XOR with the LSB of the ADC conversion result
2-0	RESERVED	R/W	2h	Reserved. Do not change from the default reset value.

**7.2.3 Register 13h (offset = 13h) [reset = 0h]**

**Figure 7-17. Register 13h**

15	14	13	12	11	10	9	8
RESERVED							
R/W-0h							
7	6	5	4	3	2	1	0
RAMP_INC_A				TP_MODE_CH[4:1]		TP_EN_CH[4:1]	RESERVED
R/W-0h				R/W-0h		R/W-0h	R/W-0h

**Figure 7-18. Register 13h Field Descriptions**

Bit	Field	Type	Reset	Description
15-8	RESERVED	R/W	0h	Reserved. Do not change from the default reset value.
7-4	RAMP_INC_A	R/W	0h	Increment value for the ramp pattern output. The output ramp increments by N+1, where N is the value configured in this register.
3-2	TP_MODE_CH[4:1]	R/W	0h	Select digital test pattern for analog input channels 1, 2, 3, and 4. 0 : Fixed pattern from the TP0_A register 1 : Fixed pattern from the TP0_A register 2 : Digital ramp output 3 : Alternate fixed pattern output from the TP0_A and TP1_A registers
1	TP_EN_CH[4:1]	R/W	0h	Enable digital test pattern for data corresponding to analog input channels 1, 2, 3, and 4. 0 : Data output is the ADC conversion result 1 : Data output is the digital test pattern
0	RESERVED	R/W	0h	Reserved. Do not change from the default reset value.

**7.2.4 Register 14h (offset = 14h) [reset = 0h]**

**Figure 7-19. Register 14h**

15	14	13	12	11	10	9	8
TP0_A[15:0]							
R/W-0h							
7	6	5	4	3	2	1	0
TP0_A[15:0]							
R/W-0h							

**Figure 7-20. Register 14h Field Descriptions**

Bit	Field	Type	Reset	Description
15-0	TP0_A[15:0]	R/W	0h	Lower 16 bits of test pattern 0

### 7.2.5 Register 15h (offset = 15h) [reset = 0h]

**Figure 7-21. Register 15h**

15	14	13	12	11	10	9	8
TP1_A[7:0]							
R/W-0h							
7	6	5	4	3	2	1	0
TP0_A[23:16]							
R/W-0h							

**Figure 7-22. Register 15h Field Descriptions**

Bit	Field	Type	Reset	Description
15-8	TP1_A[7:0]	R/W	0h	Lower eight bits of test pattern 1
7-0	TP0_A[23:16]	R/W	0h	Upper eight bits of test pattern 0

### 7.2.6 Register 16h (offset = 16h) [reset = 0h]

**Figure 7-23. Register 16h**

15	14	13	12	11	10	9	8
TP1_A[23:8]							
R/W-0h							
7	6	5	4	3	2	1	0
TP1_A[23:8]							
R/W-0h							

**Figure 7-24. Register 16h Field Descriptions**

Bit	Field	Type	Reset	Description
15-0	TP1_A[23:8]	R/W	0h	Upper 16 bits of test pattern 1

7.2.7 Register 18h (offset = 18h) [reset = 0h]

Figure 7-25. Register 18h

15	14	13	12	11	10	9	8
RESERVED							
R/W-0h							
7	6	5	4	3	2	1	0
RAMP_INC_B				TP_MODE_B		TP_EN_B	RESERVED
R/W-0h				R/W-0h		R/W-0h	R/W-0h

Figure 7-26. Register 18h Field Descriptions

Bit	Field	Type	Reset	Description
15-8	RESERVED	R/W	0h	Reserved. Do not change from the default reset value.
7-4	RAMP_INC_B	R/W	0h	Increment value for the ramp pattern output. The output ramp increments by N+1, where N is the value configured in this register.
3-2	TP_MODE_CH[8:5]	R/W	0h	Select digital test pattern for analog input channels 5, 6, 7, and 8. 0 : Fixed pattern from the TP0_B register 1 : Fixed pattern from the TP0_B register 2 : Digital ramp output 3 : Alternate fixed pattern output from the TP0_B and TP1_B registers
1	TP_EN_CH[8:5]	R/W	0h	Enable digital test pattern for data corresponding to analog input channels 5, 6, 7, and 8. 0 : Data output is the ADC conversion result 1 : Data output is the digital test pattern
0	RESERVED	R/W	0h	Reserved. Do not change from the default reset value.

7.2.8 Register 19h (offset = 19h) [reset = 0h]

Figure 7-27. Register 19h

15	14	13	12	11	10	9	8
TP0_B[15:0]							
R/W-0h							
7	6	5	4	3	2	1	0
TP0_B[15:0]							
R/W-0h							

Figure 7-28. Register 19h Field Descriptions

Bit	Field	Type	Reset	Description
15-0	TP0_B[15:0]	R/W	0h	Lower 16 bits of test pattern 0

### 7.2.9 Register 1Ah (offset = 1Ah) [reset = 0h]

**Figure 7-29. Register 1Ah**

15	14	13	12	11	10	9	8
TP1_B[7:0]							
R/W-0h							
7	6	5	4	3	2	1	0
TP0_B[23:16]							
R/W-0h							

**Figure 7-30. Register 1Ah Field Descriptions**

Bit	Field	Type	Reset	Description
15-8	TP1_B[7:0]	R/W	0h	Lower eight bits of test pattern 1
7-0	TP0_B[23:16]	R/W	0h	Upper eight bits of test pattern 0

### 7.2.10 Register 1Bh (offset = 1Bh) [reset = 0h]

**Figure 7-31. Register 1Bh**

15	14	13	12	11	10	9	8
TP1_B[23:8]							
R/W-0h							
7	6	5	4	3	2	1	0
TP1_B[23:8]							
R/W-0h							

**Figure 7-32. Register 1Bh Field Descriptions**

Bit	Field	Type	Reset	Description
15-0	TP1_B[23:8]	R/W	0h	Upper 16 bits of test pattern 1

### Register 1Ch (offset = 1Ch) [reset = 0h]

**Figure 7-33. Register 1Ch**

15	14	13	12	11	10	9	8
RESERVED		USER_BITS_CH[8:5]					
R/W-0h		R/W-0h					
7	6	5	4	3	2	1	0
RESERVED		USER_BITS_CH[4:1]					
R/W-0h		R/W-0h					

**Figure 7-34. Register 1Ch Field Descriptions**

Bit	Field	Type	Reset	Description
15-8	USER_BITS_CH[8:5]	R/W	0h	User-defined bits appended to the ADC conversion result from analog input channels 5, 6, 7, and 8.
7-0	USER_BITS_CH[4:1]	R/W	0h	User-defined bits appended to the ADC conversion result from analog input channels 1, 2, 3, and 4.

### 7.2.11 Register 33h (offset = 33h) [reset = 0h]

**Figure 7-35. Register 33h**

15	14	13	12	11	10	9	8
RESERVED		GE_CAL_EN3	RESERVED				

**Figure 7-35. Register 33h (continued)**

R/W-0h		R/W-0h	R/W-0h				
7	6	5	4	3	2	1	0
RESERVED	GE_CAL_EN2	INIT_KEY		RESERVED			
R/W-0h	R/W-0h	R/W-0h		R/W-0h			

**Figure 7-36. Register 33h Field Descriptions**

Bit	Field	Type	Reset	Description
15-14	RESERVED	R/W	0h	Reserved. Do not change from the default reset value.
13	GE_CAL_EN3	R/W	0h	Global control for gain error calibration. 0 : Gain error calibration disabled for all channels 1 : Gain error calibration enabled for all channels
12-7	RESERVED	R/W	0h	Reserved. Do not change from the default reset value.
6	GE_CAL_EN2	R/W	0h	Global control for gain error calibration. 0 : Gain error calibration disabled for all channels 1 : Gain error calibration enabled for all channels
5-4	INIT_KEY	R/W	0h	Device initialization sequence access key. Write 11b to access the device initialization sequence. Write 00b for normal operation.
3-0	RESERVED	R/W	0h	Reserved. Do not change from the default reset value.



**7.2.12 Register 34h (offset = 34h) [reset = 0h]**

**Figure 7-37. Register 34h**

15	14	13	12	11	10	9	8
RESERVED							
R/W-0h							
7	6	5	4	3	2	1	0
RESERVED			GE_CAL_EN4	RESERVED			
R/W-0h			R/W-0h	R/W-0h			

**Figure 7-38. Register 34h Field Descriptions**

Bit	Field	Type	Reset	Description
15-5	RESERVED	R/W	0h	Reserved. Do not change from the default reset value.
4	GE_CAL_EN4	R/W	0h	Global control for gain error calibration. 0 : Gain error calibration disabled for all channels 1 : Gain error calibration enabled for all channels
3-0	RESERVED	R/W	0h	Reserved. Do not change from the default reset value.

**7.2.13 Register C0h (offset = C0h) [reset = 0h]**

**Figure 7-39. Register C0h**

15	14	13	12	11	10	9	8
RESERVED						ANA_BW	
R/W-0h						R/W-0h	
7	6	5	4	3	2	1	0
ANA_BW						PD_CH	
R/W-0h						R/W-0h	

**Figure 7-40. Register C0h Field Descriptions**

Bit	Field	Type	Reset	Description
15-10	RESERVED	R/W	0h	Reserved. Do not change from the default reset value.
9-2	ANA_BW	R/W	0h	Select analog input bandwidth for the respective analog input channels. MSB = BW control for channel 8. LSB = BW control for channel 1. 0 : Low-noise mode 1 : Wide-bandwidth mode
1-0	PD_CH	R/W	0h	Power-down control for the analog input channels. 0 : Normal operation 1 : Analog input channels 5, 6, 7, and 8 powered down 2 : Analog input channels 1, 2, 3, and 4 powered down 3 : All channels powered down

**7.2.14 Register C1h (offset = C1h) [reset = 0h]**

**Figure 7-41. Register C1h**

15	14	13	12	11	10	9	8
RESERVED				PD_REF	RESERVED	DATA_LANES	DATA_RATE
R/W-0h				R/W-0h	R/W-0h	R/W-0h	R/W-0h
7	6	5	4	3	2	1	0
RESERVED							
R/W-0h							

**Figure 7-42. Register C1h Field Descriptions**

Bit	Field	Type	Reset	Description
15-12	RESERVED	R/W	0h	Reserved. Do not change from the default reset value.
11	PD_REF	R/W	0h	ADC reference voltage source selection. 0 : Internal reference enabled. 1 : Internal reference disabled. Connect the external reference voltage to the REFIO pin.
10	RESERVED	R/W	0h	Reserved. Do not change from the default reset value.
9	DATA_LANES	R/W	0h	Select number of output data lanes per ADC channel. 0 : 4-lane mode. CH[4:1] data are output on pins D3 and D2. CH[8:5] data are output on pins D1 and D0. 1 : 2-lane mode. CH[4:1] data are output on pin D3. CH[8:5] data are output on pin D1.
8	DATA_RATE	R/W	0h	Select data rate for the data interface. 0 : Double data rate (DDR) 1 : Single data rate (SDR)
7-0	RESERVED	R/W	0h	Reserved. Do not change from the default reset value.

### 7.2.15 Register C2h (offset = C2h) [reset = 0h]

**Figure 7-43. Register C2h**

15	14	13	12	11	10	9	8
RANGE_CH4				RANGE_CH3			
R/W-0h				R/W-0h			
7	6	5	4	3	2	1	0
RANGE_CH2				RANGE_CH1			
R/W-0h				R/W-0h			

**Figure 7-44. Register C2h Field Descriptions**

Bit	Field	Type	Reset	Description
15-12	RANGE_CH4	R/W	0h	Select input voltage range for respective ADC channels. 0 : ±5V 1 : ±3.5V 2 : ±2.5V 3 : ±7V 4 : ±10V 5 : ±12V
11-8	RANGE_CH3	R/W	0h	
7-4	RANGE_CH2	R/W	0h	
3-0	RANGE_CH1	R/W	0h	

7.2.16 Register C3h (offset = C3h) [reset = 0h]

Figure 7-45. Register C3h

15	14	13	12	11	10	9	8
RANGE_CH8				RANGE_CH7			
R/W-0h				R/W-0h			
7	6	5	4	3	2	1	0
RANGE_CH6				RANGE_CH5			
R/W-0h				R/W-0h			

Figure 7-46. Register C3h Field Descriptions

Bit	Field	Type	Reset	Description
15-12	RANGE_CH8	R/W	0h	Select input voltage range for respective ADC channels. 0 : ±5V 1 : ±3.5V 2 : ±2.5V 3 : ±7V 4 : ±10V 5 : ±12V
11-8	RANGE_CH7	R/W	0h	
7-4	RANGE_CH6	R/W	0h	
3-0	RANGE_CH5	R/W	0h	

**7.2.17 Register C4h (offset = C4h) [reset = 0h]**
**Figure 7-47. Register C4h**

15	14	13	12	11	10	9	8
RESERVED						CM_RNG_CH[8:5]	
R/W-0h						R/W-0h	
7	6	5	4	3	2	1	0
CM_RNG_CH[4:1]		RESERVED		CM_EN_CH[8:5]	CM_EN_CH[4:1]	RESERVED	PD_CHIP
R/W-0h		R/W-0h		R/W-0h	R/W-0h	R/W-0h	R/W-0h

**Figure 7-48. Register C4h Field Descriptions**

Bit	Field	Type	Reset	Description
15-10	RESERVED	R/W	0h	Reserved. Do not change from the default reset value.
9-8	CM_RNG_CH[8:5]	R/W	0h	CM_RNG_CH[8:5] sets the common-mode voltage range for analog input channels 5, 6, 7, and 8.
7-6	CM_RNG_CH[4:1]	R/W	0h	CM_RNG_CH[4:1] sets the common-mode voltage range for analog input channels 1, 2, 3, and 4 0 : CM range equal to $\pm$ RANGE / 2 1 : CM range equal to $\pm$ 6V 2 : CM range equal to $\pm$ 12V
5-4	RESERVED	R/W	0h	Reserved. Do not change from the default reset value.
3	CM_EN_CH[8:5]	R/W	0h	CM_EN_CH[8:5] enables the common-mode range control for analog input channels 5, 6, 7, and 8.
2	CM_EN_CH[4:1]	R/W	0h	CM_EN_CH[4:1] enables the common-mode range control for analog input channels 1, 2, 3, and 4 0 : Wide-common-mode range control disabled 1 : Wide-common-mode range control enabled
1	RESERVED	R/W	0h	Reserved. Do not change from the default reset value.
0	PD_CHIP	R/W	0h	Full chip power-down control. 0 : Normal device operation 1 : Full device powered-down

**7.2.18 Register C5h (offset = C5h) [reset = 0h]**

**Figure 7-49. Register C5h**

15	14	13	12	11	10	9	8
RESERVED							
R/W-0h							
7	6	5	4	3	2	1	0
RESERVED			CM_CTRL_EN	RESERVED			
R/W-0h			R/W-0h	R/W-0h			

**Figure 7-50. Register C5h Field Descriptions**

Bit	Field	Type	Reset	Description
15-5	RESERVED	R/W	0h	Reserved. Do not change from the default reset value.
4	CM_CTRL_EN	R/W	0h	Enable wide-common-mode range control for all analog input channels. 0 : CM range for all analog input channels is ±12V 1 : CM range is user-defined in the CM_EN_CH[8:5], CM_EN_CH[8:5], CM_RNG_CH[4:1], and CM_RNG_CH[8:5] registers
3-0	RESERVED	R/W	0h	Reserved. Do not change from the default reset value.

**7.2.19 Register F4h (offset = F4h) [reset = 0h]**

**Figure 7-51. Register F4h**

15	14	13	12	11	10	9	8
RESERVED							
R/W-0h							
7	6	5	4	3	2	1	0
RESERVED						INIT	RESERVED
R/W-0h						R/W-0h	R/W-0h

**Figure 7-52. Register F4h Field Descriptions**

Bit	Field	Type	Reset	Description
15-2	RESERVED	R/W	0h	Reserved. Do not change from the default reset value.
1	INIT	R/W	0h	INIT field for device initialization. Write 1b during the initialization sequence. Write 0b for normal operation.
0	RESERVED	R/W	0h	Reserved. Do not change from the default reset value.

**7.2.20 Register F6h (offset = F6h) [reset = 0h]**

**Figure 7-53. Register F6h**

15	14	13	12	11	10	9	8
RESERVED							
R/W-0h							
7	6	5	4	3	2	1	0
RESERVED						INIT_2	RESERVED
R/W-0h						R/W-0h	R/W-0h

**Figure 7-54. Register F6h Field Descriptions**

Bit	Field	Type	Reset	Description
15-2	RESERVED	R/W	0h	Reserved. Do not change from the default reset value.
1	INIT_2	R/W	0h	INIT_2 field for device initialization. Write 1b during the initialization sequence. Write 0b for normal operation.
0	RESERVED	R/W	0h	Reserved. Do not change from the default reset value.

### 7.3 Register Bank 2

Figure 7-55. Register Bank 2 Map

ADD	D15	D14	D13	D12	D11	D10	D9	D8	D7	D6	D5	D4	D3	D2	D1	D0
0Ah	RESERVED	INIT_5	RESERVED													
12h	RESERVED									INIT_3	RESERVED					
13h	INIT_4	RESERVED														

Table 7-3. Register Section/Block Access Type Codes

Access Type	Code	Description
R	R	Read
W	W	Write
R/W	R/W	Read or write
Reset or Default Value		
-n		Value after reset or the default value

#### 7.3.1 Register 0Ah (offset = 0Ah) [reset = 0h]

Figure 7-56. Register 0Ah

15	14	13	12	11	10	9	8
RESERVED	INIT_5	RESERVED					
R/W-0h		R/W-0h					
7	6	5	4	3	2	1	0
RESERVED							
R/W-0h							

Figure 7-57. Register 0A Field Descriptions

Bit	Field	Type	Reset	Description
15	RESERVED	R/W	0h	Reserved. Do not change from the default reset value.
14	INIT_5	R/W	0h	INIT_5 field for device initialization. Write 1b during initialization sequence. Write 0b for normal operation. Refer to <a href="#">Initialization Sequence</a> for more details.
13-0	RESERVED	R/W	0h	Reserved. Do not change from the default reset value.

#### 7.3.2 Register 12h (offset = 12h) [reset = 0h]

Figure 7-58. Register 12h

15	14	13	12	11	10	9	8
RESERVED							
R/W-0h							
7	6	5	4	3	2	1	0
RESERVED	INIT_3	RESERVED					
R/W-0h		R/W-0h					

Figure 7-59. Register 12 Field Descriptions

Bit	Field	Type	Reset	Description
15-7	RESERVED	R/W	0h	Reserved. Do not change from the default reset value.



**Figure 7-59. Register 12 Field Descriptions (continued)**

Bit	Field	Type	Reset	Description
6-6	INIT_3	R/W	0h	INIT_3 field for device initialization. Write 1b during the initialization sequence. Write 0b for normal operation. Refer to <a href="#">Initialization Sequence</a> for more details.
5-0	RESERVED	R/W	0h	Reserved. Do not change from the default reset value.

### 7.3.3 Register 13h (offset = 13h) [reset = 0h]

**Figure 7-60. Register 13h**

15	14	13	12	11	10	9	8
INIT_4		RESERVED					
R/W-0h		R/W-0h					
7	6	5	4	3	2	1	0
RESERVED							
R/W-0h							

**Figure 7-61. Register 13 Field Descriptions**

Bit	Field	Type	Reset	Description
15-15	INIT_4	R/W	0h	INIT_4 field for device initialization. Write 1b during initialization sequence. Write 0b for normal operation. Refer to <a href="#">Initialization Sequence</a> for more details.
14-0	RESERVED	R/W	0h	Reserved. Do not change from the default reset value.

## 8 Application and Implementation

### Note

Information in the following applications sections is not part of the TI component specification, and TI does not warrant its accuracy or completeness. TI's customers are responsible for determining suitability of components for their purposes, as well as validating and testing their design implementation to confirm system functionality.

### 8.1 Application Information

The ADS981x enables high-precision measurement of up to eight analog signals. The following section gives an example application circuit and recommendations for using the ADS981x in automated test equipment (ATE) systems.

### 8.2 Typical Application

#### 8.2.1 Parametric Measurement Unit (PMU)

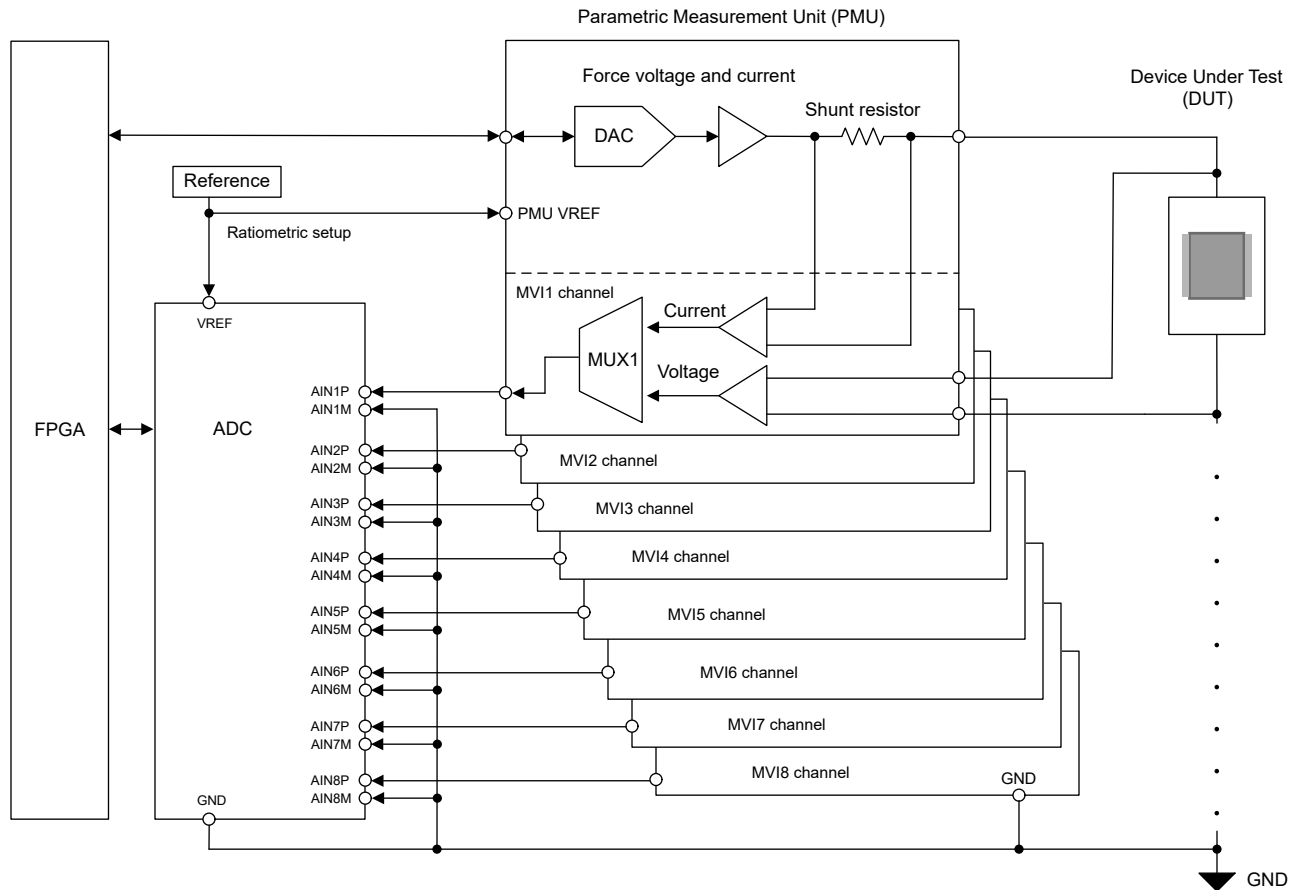
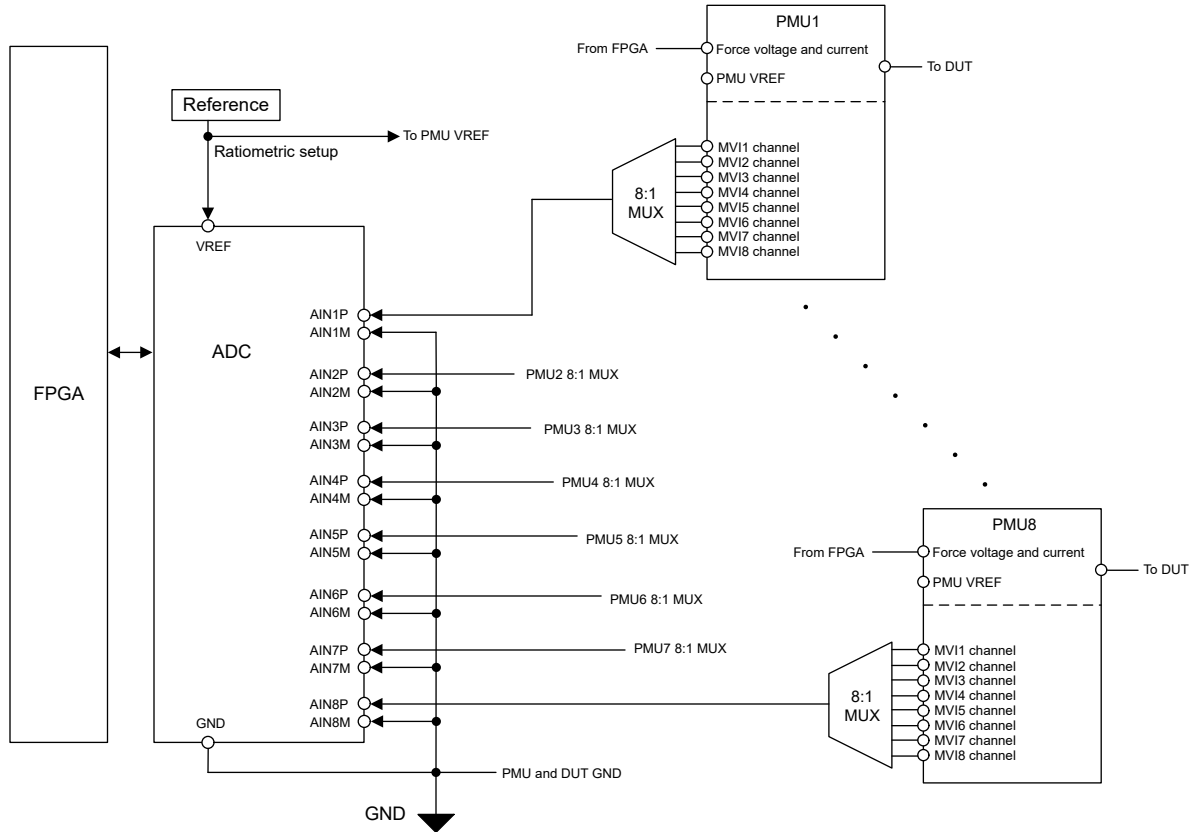

Figure 8-1. Typical PMU



**Figure 8-2. PMU With a Multiplexer**

### 8.2.2 Design Requirements

The goal of this application is to select an ADC for ATE applications. [Table 8-1](#) shows the parameters for this design example.

**Table 8-1. Design Parameters**

PARAMETER	VALUE
Sampling rate	Up to 2MSPS/channel
Total unadjusted error (TUE) over 25°C ±5°C	<0.01% with calibration
Supports external switches or multiplexer	Full-scale step settling to 99.99% of full-scale in <1.8µs

### 8.2.3 Detailed Design Procedure

The ADS981x is an eight-channel, 18-bit, 2MSPS data acquisition (DAQ) system. The device has a built-in analog front-end that makes the ATE signal chain easier to design and more accurate.

The ADC accuracy is based on the total-unadjusted-error (TUE), which combines INL, offset, and gain errors. Calibrate the external system for offset and gain errors at a specified temperature and supply voltage. When calibrated (as described in [Table 8-2](#)), only the INL, thermal offset drift, and thermal gain drift contribute to the TUE. The ADS981x has a TUE of 0.0016% at 25°C ±5°C post-calibration, meeting the design error requirement.

**Table 8-2. TUE at T<sub>A</sub> = 25°C Calculation**

CALIBRATION	INL (ppm)	OFFSET ERROR (ppm)	GAIN ERROR (ppm)	TUE (ppm)	ERROR (%)
No calibration	15.26	495.9	183.1	528.8	0.053
Post-calibration	15.26	0	0	15.3	0.0015
Post-calibration ±5°C	15.26	2.5	3.5	15.9	0.0016

The pin-electronics subsystem manages the PMU outputs. The subsystem connects each PMU output to separate ADC channels ([Figure 8-1](#)) or uses a multiplexer to link multiple PMU outputs to one ADC channel ([Figure 8-2](#)). This subsystem allows more pin-electronics channels on the card. The ADC requires more bandwidth with multiplexers ([Table 8-3](#)) for fast settling when switching PMU channels. The ADS981x has two bandwidth modes: Low-noise (up to 21kHz) and wide-bandwidth (up to 400kHz). As described in [Table 8-3](#) the wide-bandwidth mode samples multiplexed PMU signals and settles to 99.99% FS in 13µs.

**Table 8-3. Step-Settling Performance**

ANALOG INPUT BANDWIDTH	SETTLING TIME		
	99.90% of FS	99.95% of FS	99.99% of FS
Low BW (21kHz)	56µs	61µs	76µs
Wide BW (400kHz)	7µs	8µs	13µs

### 8.2.4 Application Curve

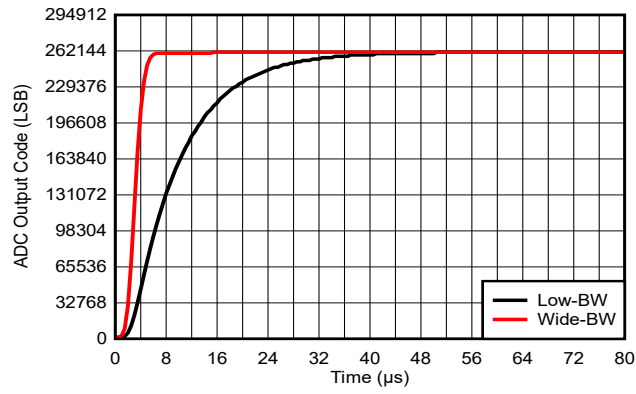

**Figure 8-3. Step-Settling Performance**

## 8.3 Power Supply Recommendations

The ADS981x has three separate power supplies: AVDD\_5V, VDD\_1V8, and IOVDD. There is no requirement for a specific power-up sequence. The data and configuration digital interfaces are powered by IOVDD. A common 1.8V supply powers the VDD\_1V8 and IOVDD pins. [Figure 8-4](#) illustrates the decoupling capacitor connections for the respective power supplies. Make sure each power-supply pin has separate decoupling capacitors.

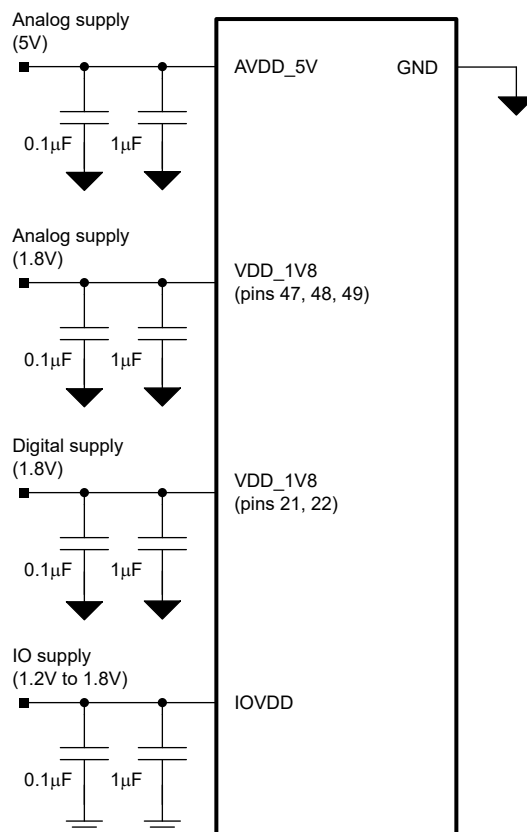

**Figure 8-4. Power-Supply Decoupling**

## 8.4 Layout

### 8.4.1 Layout Guidelines

[Figure 8-5](#) illustrates a board layout example for the ADS981x. Avoid crossing digital lines with the analog signal path and keep the analog input signals and the reference signals away from noise sources.

Use 0.1µF ceramic bypass capacitors in close proximity to the AVDD\_5V, VDD\_1V8, and IOVDD power-supply pins. Avoid placing vias between the power-supply pins and the bypass capacitors.

Place the reference decoupling capacitor close to the device REFIO and REFM pins. Avoid placing vias between the REFIO pin and the bypass capacitors. Connect the GND, REFM, and GND pins to a ground plane using short, low-impedance paths.

### 8.4.2 Layout Example

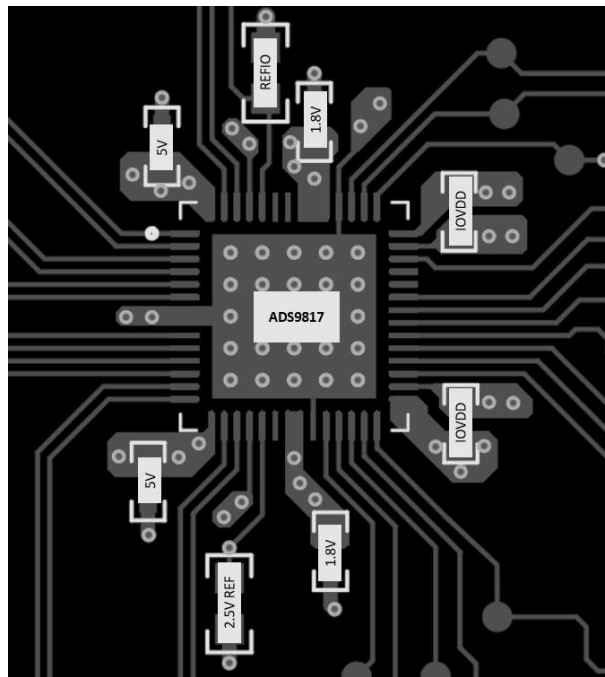

Figure 8-5. Example Layout

## 9 Device and Documentation Support

TI offers an extensive line of development tools. Tools and software to evaluate the performance of the device, generate code, and develop solutions are listed below.

### 9.1 Receiving Notification of Documentation Updates

To receive notification of documentation updates, navigate to the device product folder on [ti.com](http://ti.com). Click on *Notifications* to register and receive a weekly digest of any product information that has changed. For change details, review the revision history included in any revised document.

### 9.2 Support Resources

TI E2E™ [support forums](#) are an engineer's go-to source for fast, verified answers and design help — straight from the experts. Search existing answers or ask your own question to get the quick design help you need.

Linked content is provided "AS IS" by the respective contributors. They do not constitute TI specifications and do not necessarily reflect TI's views; see TI's [Terms of Use](#).

### 9.3 Trademarks

TI E2E™ is a trademark of Texas Instruments.

All trademarks are the property of their respective owners.

### 9.4 Electrostatic Discharge Caution



This integrated circuit can be damaged by ESD. Texas Instruments recommends that all integrated circuits be handled with appropriate precautions. Failure to observe proper handling and installation procedures can cause damage.

ESD damage can range from subtle performance degradation to complete device failure. Precision integrated circuits may be more susceptible to damage because very small parametric changes could cause the device not to meet its published specifications.

### 9.5 Glossary

[TI Glossary](#) This glossary lists and explains terms, acronyms, and definitions.

## 10 Revision History

NOTE: Page numbers for previous revisions may differ from page numbers in the current version.

Changes from Revision A (December 2023) to Revision B (October 2024)	Page
• Changed INL value from $\pm 1.5\text{LSB}$ to $\pm 0.8\text{LSB}$ throughout document.....	1
• Changed <i>DAISY_CHAIN_LENGTH</i> to <i>DAISY_CHAIN_LEN</i> throughout document.....	1
• Deleted pulldown resistor discussion from SCLK pin description in <i>Pin Functions</i> table.....	3
• Deleted offset error matching specifications.....	7
• Changed gain error specification units from LSB to %FSR.....	7
• Deleted gain error matching specifications.....	7
• Changed maximum power-down current from IOVDD for ADS9817.....	7
• Updated <i>Typical Characteristics</i> section.....	14
• Changed low-bandwidth corner frequency from 21.1kHz to 21kHz and wide-bandwidth corner frequency from 185kHz to 182kHz in <i>Low-Pass Filter Corner Frequency</i> table.....	22
• Updated <i>Test Patterns for Data Interface</i> section.....	29
• Updated steps 1b and 2 in <i>Register Read With Daisy-Chain</i> section.....	37
• Updated <i>Register Bank 1</i> section.....	42
• Updated <i>Application Information</i> section.....	58
• Updated <i>Typical Application</i> section.....	58



---

<b>Changes from Revision * (January 2023) to Revision A (December 2023)</b>	<b>Page</b>
• Changed document status from <i>Advance Information</i> to <i>Production Data</i> .....	<a href="#">1</a>

---

## 11 Mechanical, Packaging, and Orderable Information

The following pages include mechanical, packaging, and orderable information. This information is the most current data available for the designated devices. This data is subject to change without notice and revision of this document. For browser-based versions of this data sheet, refer to the left-hand navigation.

**PACKAGING INFORMATION**

Orderable Device	Status (1)	Package Type	Package Drawing	Pins	Package Qty	Eco Plan (2)	Lead finish/ Ball material (6)	MSL Peak Temp (3)	Op Temp (°C)	Device Marking (4/5)	Samples
ADS9815RSHR	ACTIVE	VQFN	RSH	56	2500	RoHS & Green	NIPDAU	Level-3-260C-168 HR	-40 to 125	ADS9815	<a href="#">Samples</a>
ADS9817RSHR	ACTIVE	VQFN	RSH	56	2500	RoHS & Green	NIPDAU	Level-3-260C-168 HR	-40 to 125	ADS9817	<a href="#">Samples</a>
ADS9817RSHT	ACTIVE	VQFN	RSH	56	250	RoHS & Green	NIPDAU	Level-3-260C-168 HR	-40 to 125	ADS9817	<a href="#">Samples</a>
PADS9815RSHT	ACTIVE	VQFN	RSH	56	250	TBD	Call TI	Call TI	-40 to 125		<a href="#">Samples</a>

(1) The marketing status values are defined as follows:

**ACTIVE:** Product device recommended for new designs.

**LIFEBUY:** TI has announced that the device will be discontinued, and a lifetime-buy period is in effect.

**NRND:** Not recommended for new designs. Device is in production to support existing customers, but TI does not recommend using this part in a new design.

**PREVIEW:** Device has been announced but is not in production. Samples may or may not be available.

**OBSOLETE:** TI has discontinued the production of the device.

(2) **RoHS:** TI defines "RoHS" to mean semiconductor products that are compliant with the current EU RoHS requirements for all 10 RoHS substances, including the requirement that RoHS substance do not exceed 0.1% by weight in homogeneous materials. Where designed to be soldered at high temperatures, "RoHS" products are suitable for use in specified lead-free processes. TI may reference these types of products as "Pb-Free".

**RoHS Exempt:** TI defines "RoHS Exempt" to mean products that contain lead but are compliant with EU RoHS pursuant to a specific EU RoHS exemption.

**Green:** TI defines "Green" to mean the content of Chlorine (Cl) and Bromine (Br) based flame retardants meet JS709B low halogen requirements of <=1000ppm threshold. Antimony trioxide based flame retardants must also meet the <=1000ppm threshold requirement.

(3) MSL, Peak Temp. - The Moisture Sensitivity Level rating according to the JEDEC industry standard classifications, and peak solder temperature.

(4) There may be additional marking, which relates to the logo, the lot trace code information, or the environmental category on the device.

(5) Multiple Device Markings will be inside parentheses. Only one Device Marking contained in parentheses and separated by a "-" will appear on a device. If a line is indented then it is a continuation of the previous line and the two combined represent the entire Device Marking for that device.

(6) Lead finish/Ball material - Orderable Devices may have multiple material finish options. Finish options are separated by a vertical ruled line. Lead finish/Ball material values may wrap to two lines if the finish value exceeds the maximum column width.

**Important Information and Disclaimer:**The information provided on this page represents TI's knowledge and belief as of the date that it is provided. TI bases its knowledge and belief on information provided by third parties, and makes no representation or warranty as to the accuracy of such information. Efforts are underway to better integrate information from third parties. TI has taken and

continues to take reasonable steps to provide representative and accurate information but may not have conducted destructive testing or chemical analysis on incoming materials and chemicals. TI and TI suppliers consider certain information to be proprietary, and thus CAS numbers and other limited information may not be available for release.

In no event shall TI's liability arising out of such information exceed the total purchase price of the TI part(s) at issue in this document sold by TI to Customer on an annual basis.

**TAPE AND REEL INFORMATION**

**QUADRANT ASSIGNMENTS FOR PIN 1 ORIENTATION IN TAPE**

\*All dimensions are nominal

Device	Package Type	Package Drawing	Pins	SPQ	Reel Diameter (mm)	Reel Width W1 (mm)	A0 (mm)	B0 (mm)	K0 (mm)	P1 (mm)	W (mm)	Pin1 Quadrant
ADS9815RSHR	VQFN	RSH	56	2500	330.0	16.4	7.3	7.3	1.1	12.0	16.0	Q2
ADS9817RSHR	VQFN	RSH	56	2500	330.0	16.4	7.3	7.3	1.1	12.0	16.0	Q2
ADS9817RSHT	VQFN	RSH	56	250	180.0	16.4	7.3	7.3	1.1	12.0	16.0	Q2

**TAPE AND REEL BOX DIMENSIONS**

\*All dimensions are nominal

Device	Package Type	Package Drawing	Pins	SPQ	Length (mm)	Width (mm)	Height (mm)
ADS9815RSHR	VQFN	RSH	56	2500	367.0	367.0	35.0
ADS9817RSHR	VQFN	RSH	56	2500	367.0	367.0	35.0
ADS9817RSHT	VQFN	RSH	56	250	210.0	185.0	35.0

**RSH 56**

**GENERIC PACKAGE VIEW**

**VQFN - 1 mm max height**

PLASTIC QUAD FLATPACK - NO LEAD

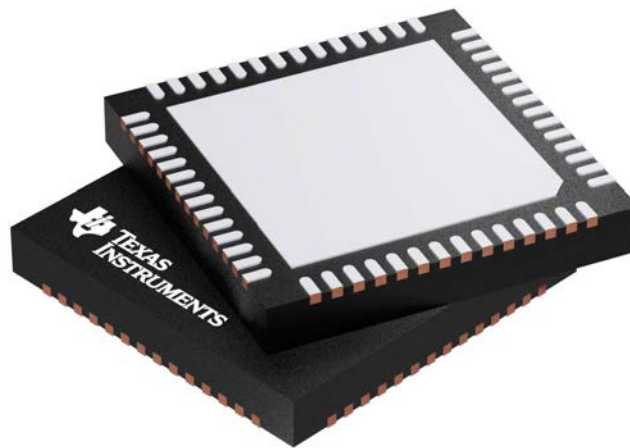

Images above are just a representation of the package family, actual package may vary.  
Refer to the product data sheet for package details.

4207513/D

# MECHANICAL DATA

RSH (S-PVQFN-N56)

PLASTIC QUAD FLATPACK NO-LEAD

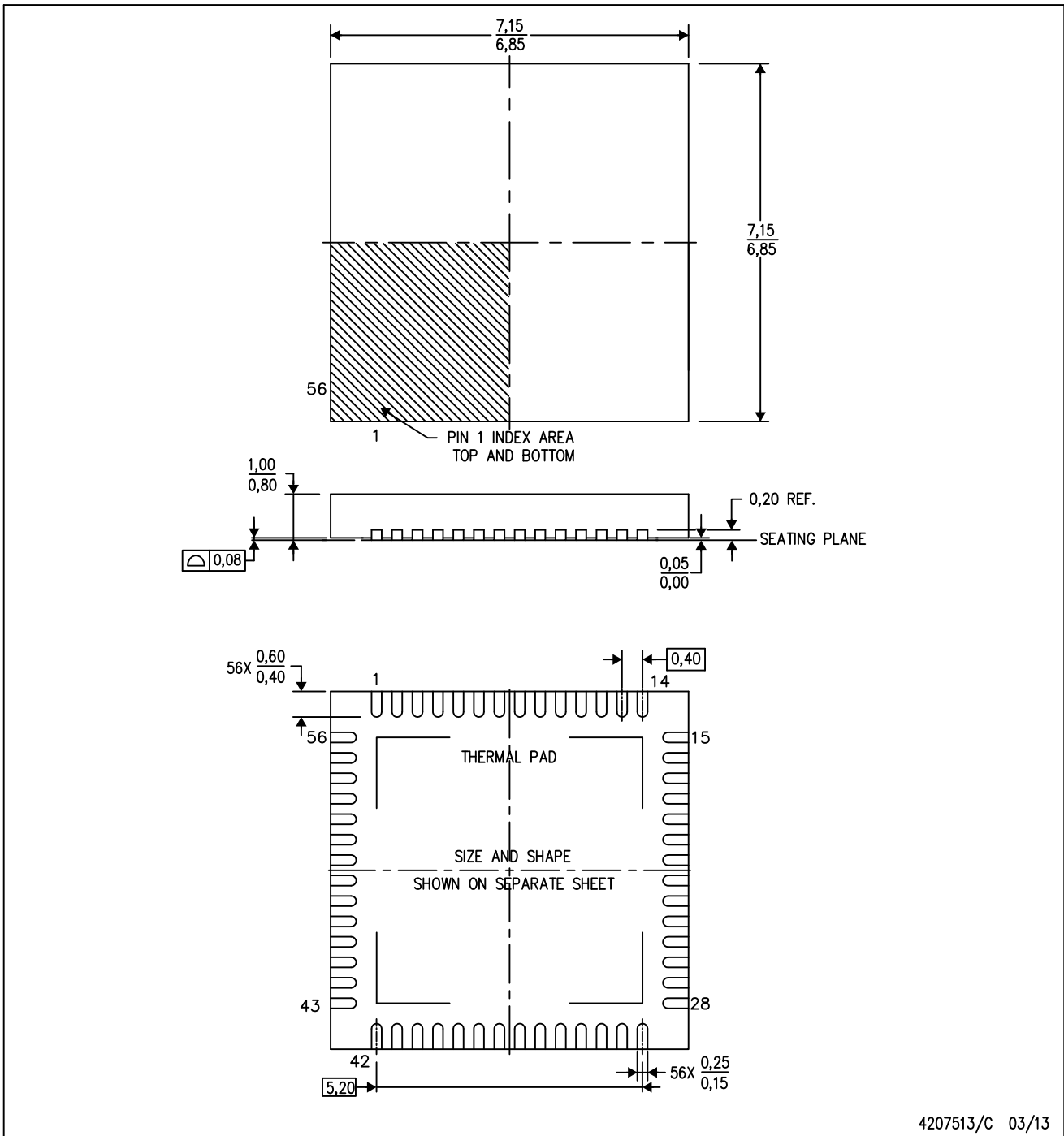

4207513/C 03/13

- NOTES:
- A. All linear dimensions are in millimeters. Dimensioning and tolerancing per ASME Y14.5M-1994.
  - B. This drawing is subject to change without notice.
  - C. Quad Flatpack, No-leads (QFN) package configuration.
  - D. The package thermal pad must be soldered to the board for thermal and mechanical performance.
  - E. See the additional figure in the Product Data Sheet for details regarding the exposed thermal pad features and dimensions.

## THERMAL PAD MECHANICAL DATA

RSH (S-PVQFN-N56)

PLASTIC QUAD FLATPACK NO-LEAD

### THERMAL INFORMATION

This package incorporates an exposed thermal pad that is designed to be attached directly to an external heatsink. The thermal pad must be soldered directly to the printed circuit board (PCB). After soldering, the PCB can be used as a heatsink. In addition, through the use of thermal vias, the thermal pad can be attached directly to the appropriate copper plane shown in the electrical schematic for the device, or alternatively, can be attached to a special heatsink structure designed into the PCB. This design optimizes the heat transfer from the integrated circuit (IC).

For information on the Quad Flatpack No-Lead (QFN) package and its advantages, refer to Application Report, QFN/SON PCB Attachment, Texas Instruments Literature No. SLUA271. This document is available at [www.ti.com](http://www.ti.com).

The exposed thermal pad dimensions for this package are shown in the following illustration.

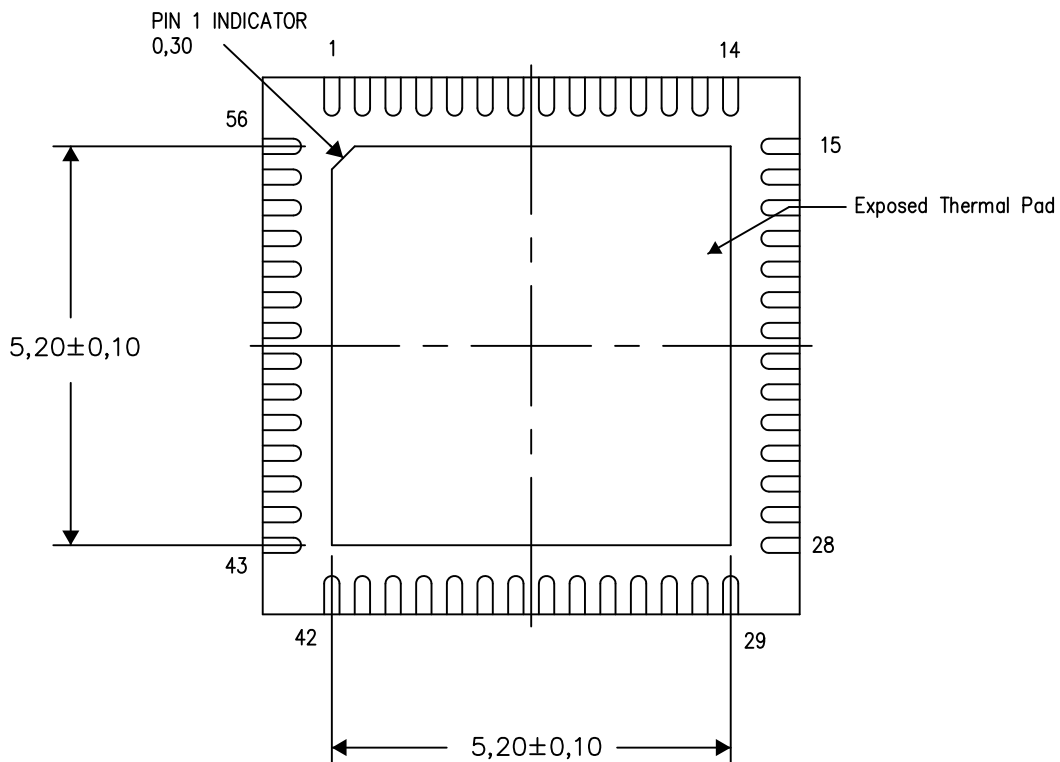

Bottom View

Exposed Thermal Pad Dimensions

4207553-2/1 07/13

NOTE: All linear dimensions are in millimeters



RSH (S-PVQFN-N56)

PLASTIC QUAD FLATPACK NO-LEAD

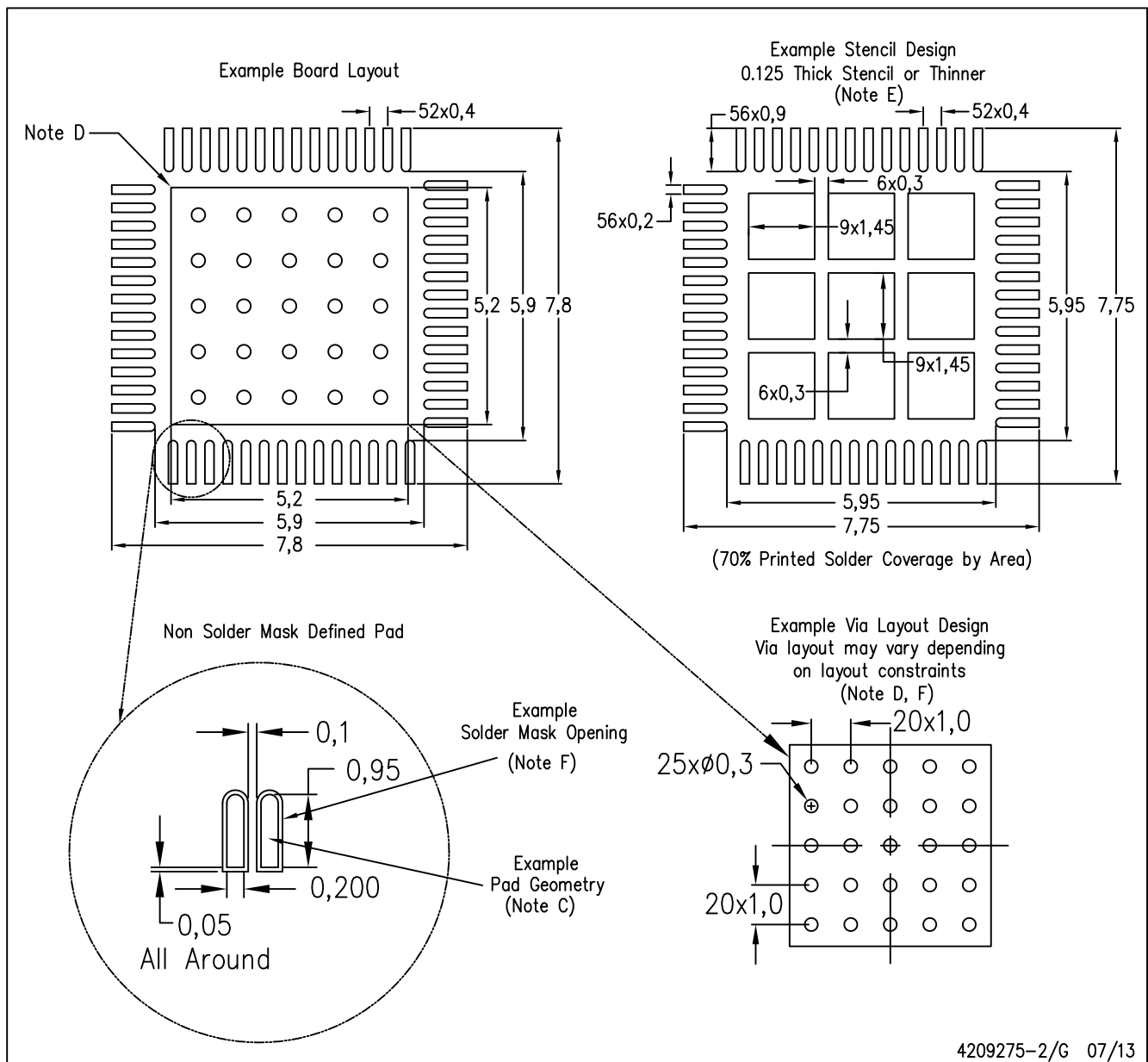

- NOTES:
- All linear dimensions are in millimeters.
  - This drawing is subject to change without notice.
  - Publication IPC-7351 is recommended for alternate designs.
  - This package is designed to be soldered to a thermal pad on the board. Refer to Application Note, Quad Flat-Pack Packages, Texas Instruments Literature No. SLUA271, and also the Product Data Sheets for specific thermal information, via requirements, and recommended board layout. These documents are available at [www.ti.com](http://www.ti.com) <<http://www.ti.com>>.
  - Laser cutting apertures with trapezoidal walls and also rounding corners will offer better paste release. Customers should contact their board assembly site for stencil design recommendations. Refer to IPC 7525 for stencil design considerations.
  - Customers should contact their board fabrication site for recommended solder mask tolerances and via tenting recommendations for vias placed in the thermal pad.

## IMPORTANT NOTICE AND DISCLAIMER

TI PROVIDES TECHNICAL AND RELIABILITY DATA (INCLUDING DATA SHEETS), DESIGN RESOURCES (INCLUDING REFERENCE DESIGNS), APPLICATION OR OTHER DESIGN ADVICE, WEB TOOLS, SAFETY INFORMATION, AND OTHER RESOURCES "AS IS" AND WITH ALL FAULTS, AND DISCLAIMS ALL WARRANTIES, EXPRESS AND IMPLIED, INCLUDING WITHOUT LIMITATION ANY IMPLIED WARRANTIES OF MERCHANTABILITY, FITNESS FOR A PARTICULAR PURPOSE OR NON-INFRINGEMENT OF THIRD PARTY INTELLECTUAL PROPERTY RIGHTS.

These resources are intended for skilled developers designing with TI products. You are solely responsible for (1) selecting the appropriate TI products for your application, (2) designing, validating and testing your application, and (3) ensuring your application meets applicable standards, and any other safety, security, regulatory or other requirements.

These resources are subject to change without notice. TI grants you permission to use these resources only for development of an application that uses the TI products described in the resource. Other reproduction and display of these resources is prohibited. No license is granted to any other TI intellectual property right or to any third party intellectual property right. TI disclaims responsibility for, and you will fully indemnify TI and its representatives against, any claims, damages, costs, losses, and liabilities arising out of your use of these resources.

TI's products are provided subject to [TI's Terms of Sale](#) or other applicable terms available either on [ti.com](https://www.ti.com) or provided in conjunction with such TI products. TI's provision of these resources does not expand or otherwise alter TI's applicable warranties or warranty disclaimers for TI products.

TI objects to and rejects any additional or different terms you may have proposed.

Mailing Address: Texas Instruments, Post Office Box 655303, Dallas, Texas 75265  
Copyright © 2024, Texas Instruments Incorporated