LM4041 Precision Micropower Shunt Voltage Reference

1 Features

- 1.225V Fixed and adjustable outputs (1.225V to 10V)
- Tight output tolerances and low temperature coefficient
 - Maximum 0.1%, 100ppm/°C – A grade
 - Maximum 0.2%, 100ppm/°C – B grade
 - Maximum 0.5%, 100ppm/°C – C grade
 - Maximum 1.0%, 150ppm/°C – D grade
- Low output noise . . . 20 μ V_{RMS} (typical)
- Wide operating current range . . . 45 μ A (typical) to 12mA
- Stable with all capacitive loads; no output capacitor required
- Available in
 - Industrial temperature: –40°C to 85°C
 - Extended temperature: –40°C to 125°C

2 Applications

- [Data-Acquisition Systems](#)
- [Power Supplies and Power-Supply Monitors](#)
- [Instrumentation and Test Equipment](#)
- [Process Control](#)
- [Precision Audio](#)
- [Automotive Electronics](#)
- [Energy Management/Metering](#)
- [Battery-Powered Equipment](#)

3 Description

The LM4041 series of shunt voltage references are versatile, easy-to-use references designed for a wide array of applications. These parts do not require external capacitors for operation and are stable with all capacitive loads. Additionally, the reference offers low dynamic impedance, low noise, and a low temperature coefficient to maintain a stable output voltage over a wide range of operating currents and temperatures. The LM4041 uses fuse and Zener-zap reverse breakdown voltage trim during wafer sort to offer four output voltage tolerances, ranging from 0.1% (maximum) for the A grade to 1% (maximum) for the D grade. Thus, a great deal of flexibility is offered to designers in choosing the best cost-to-performance ratio for applications. The LM4041 is available in a fixed (1.225V nominal) or an adjustable version (which requires an external resistor divider to set the output to a value between 1.225V and 10V).

Packaged in space-saving SC-70 and SOT-23-3 and requiring a minimum current of 45 μ A (typical), the LM4041 also designed for portable applications. The TO-92 package also is available for through-hole packaging needs. The LM4041xl is characterized for operation over an ambient temperature range of –40°C to 85°C. The LM4041xQ is characterized for operation over an ambient temperature range of –40°C to 125°C.



4 Pin Configuration and Functions

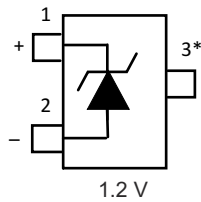

Figure 4-1. DBZ Package 3-Pin SOT-23 Top View

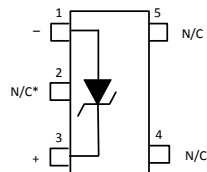

Figure 4-2. DCK Package 5-Pin SC70 Top View

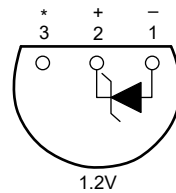

Figure 4-3. LP Package 3-Pin TO-92 Bottom View

Pin Functions

NAME	PIN			I/O	DESCRIPTION
	SOT-23	SC70	TO-92		
Anode	2	1	1	O	Anode pin, normally grounded
Cathode	1	3	2	I/O	Shunt current and output voltage
FB	—	—	—	I	Feedback pin for adjustable output voltage
NC*	3	2	3	—	**Must float or connect to anode
NC	—	4, 5	—	—	No connect

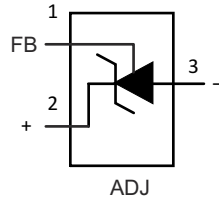

Figure 4-4. DBZ Package 3-Pin SOT-23 Top View

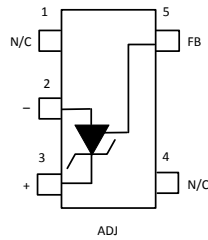

Figure 4-5. DCK Package 5-Pin SC70 Top View

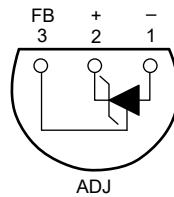

Figure 4-6. LP Package 3-Pin TO-92 Bottom View

Pin Functions: ADJ Pinouts

NAME	PIN			I/O	DESCRIPTION
	SOT-23	SC70	TO-92		
Anode	3	2	1	O	Anode pin, normally grounded
Cathode	2	3	2	I/O	Shunt current and output voltage
FB	1	5	3	I	Feedback pin for adjustable output voltage
NC**	—	—	—	—	**Must float or connect to anode
NC	—	1, 4	—	—	No connect

5 Functional Block Diagram

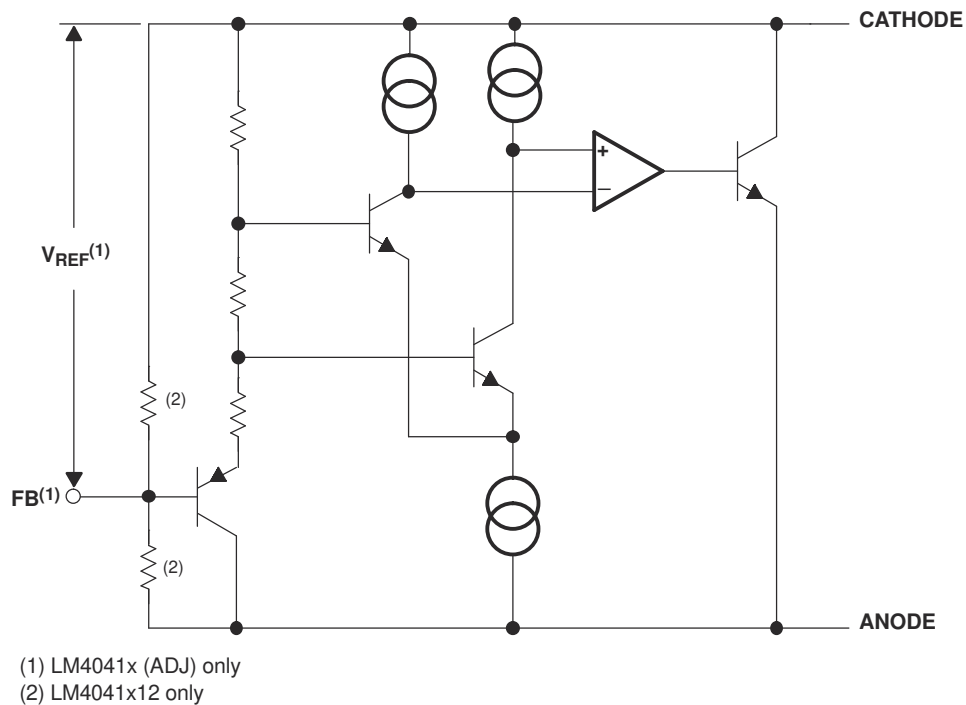

Figure 5-1. Functional Block Diagram

6 Specifications

6.1 Absolute Maximum Ratings

over free-air temperature range (unless otherwise noted)

		MIN	MAX ⁽¹⁾	UNIT
V_Z	Continuous cathode voltage		15	V
I_Z	Continuous cathode current	-10	25	mA
θ_{JA}	Package thermal impedance ^{(2) (3)}	DBZ package	206	°C/W
		DCK package	252	
		LP package	156	
T_J	Operating virtual junction temperature		150	°C
T_{stg}	Storage temperature range	-65	150	°C

- (1) Stresses beyond those listed under "absolute maximum ratings" may cause permanent damage to the device. These are stress ratings only, and functional operation of the device at these or any other conditions beyond those indicated under "recommended operating conditions" is not implied. Exposure to absolute-maximum-rated conditions for extended periods may affect device reliability.
- (2) Maximum power dissipation is a function of $T_J(\text{max})$, θ_{JA} , and T_A . The maximum allowable power dissipation at any allowable ambient temperature is $P_D = (T_J(\text{max}) - T_A)/\theta_{JA}$. Operating at the absolute maximum T_J of 150°C can affect reliability.
- (3) The package thermal impedance is calculated in accordance with JESD 51-7.

6.2 Recommended Operating Conditions

		MIN	MAX	UNIT	
I_Z	Cathode current	(1)	12	mA	
V_Z	Reverse breakdown voltage (adjustable version)		10	V	
T_A	Free-air temperature	LM4041 (I temperature)	-40	85	°C
		LM4041 (Q temperature)	-40	125	

(1) See parametric tables

6.3 LM4041x12I Electrical Characteristics

full-range $T_A = -40^\circ\text{C}$ to 85°C (unless otherwise noted)

PARAMETER	TEST CONDITIONS	T_A	LM4041A12I			LM4041B12I			UNIT			
			MIN	TYP	MAX	MIN	TYP	MAX				
V_Z	Reverse breakdown voltage	$I_Z = 100\mu\text{A}$	25°C			1.225			V			
	Reverse breakdown voltage tolerance	$I_Z = 100\mu\text{A}$	25°C			-1.2		1.2	-2.4	2.4	mV	
			Full range			-9.2		9.2	-10.4	10.4		
$I_{Z,\text{min}}$	Minimum cathode current		25°C			45		75	45	75	μA	
			Full range					80		80		
α_{VZ}	Average temperature coefficient of reverse breakdown voltage	$I_Z = 10\text{mA}$	25°C			± 20			ppm/°C			
			Full range	25°C			± 15					
				Full range			± 100					
			25°C			± 15				± 15		
$\Delta V_Z/\Delta I_Z$	Reverse breakdown voltage change with cathode current change	$I_{Z,\text{min}} < I_Z < 1\text{mA}$	25°C			0.7		1.5	0.7	1.5	mV	
			Full range			2			2			
		$1\text{mA} < I_Z < 12\text{mA}$	25°C			4		6	4	6		
			Full range			8			8			
Z_Z	Reverse dynamic impedance	$I_Z = 1\text{mA}$, $f = 120\text{Hz}$, $I_{AC} = 0.1 I_Z$	25°C			0.5		1.5	0.5	1.5	Ω	
e_N	Wideband noise	$I_Z = 100\mu\text{A}$, $10\text{Hz} \leq f \leq 10\text{kHz}$	25°C			20			20			μV_{RMS}
	Long-term stability of reverse breakdown voltage	$t = 1000\text{h}$, $T_A = 25^\circ\text{C} \pm 0.1^\circ\text{C}$, $I_Z = 100\mu\text{A}$	25°C			120			120			ppm

6.4 LM4041x12I Electrical Characteristics

full-range $T_A = -40^\circ\text{C}$ to 85°C (unless otherwise noted)

PARAMETER	TEST CONDITIONS	T_A	LM4041C12I			LM4041D12I			UNIT	
			MIN	TYP	MAX	MIN	TYP	MAX		
V_Z	Reverse breakdown voltage	$I_Z = 100\mu\text{A}$	1.225			1.225			V	
	Reverse breakdown voltage tolerance	$I_Z = 100\mu\text{A}$	25°C	-6		6		-12	12	mV
			Full range	-14		14		-24	24	
$I_{Z,\text{min}}$	Minimum cathode current		25°C	45		75		45	75	μA
			Full range			80			80	
α_{VZ}	Average temperature coefficient of reverse breakdown voltage	$I_Z = 10\text{mA}$	25°C	± 20		± 20		ppm/°C		
		$I_Z = 1\text{mA}$	25°C	± 15		± 15				
			Full range	± 100		± 150				
		$I_Z = 100\mu\text{A}$	25°C	± 15		± 15				
$\Delta V_Z/\Delta I_Z$	Reverse breakdown voltage change with cathode current change	$I_{Z,\text{min}} < I_Z < 1\text{mA}$	25°C	0.7	1.5	0.7	2	mV		
			Full range			2			2.5	
		$1\text{mA} < I_Z < 12\text{mA}$	25°C	2.5	6	2.5	8			
			Full range			8			10	
Z_Z	Reverse dynamic impedance	$I_Z = 1\text{mA}$, $f = 120\text{Hz}$, $I_{AC} = 0.1 I_Z$	25°C	0.5	1.5	0.5	2	Ω		
e_N	Wideband noise	$I_Z = 100\mu\text{A}$, $10\text{Hz} \leq f \leq 10\text{kHz}$	25°C	20		20		μV_{RMS}		
	Long-term stability of reverse breakdown voltage	$t = 1000\text{ h}$, $T_A = 25^\circ\text{C} \pm 0.1^\circ\text{C}$, $I_Z = 100\mu\text{A}$	25°C	120		120		ppm		

6.5 LM4041x12Q Electrical Characteristics

full-range $T_A = -40^\circ\text{C}$ to 125°C (unless otherwise noted)

PARAMETER	TEST CONDITIONS	T_A	LM4041C12Q			LM4041D12Q			UNIT	
			MIN	TYP	MAX	MIN	TYP	MAX		
V_Z	Reverse breakdown voltage	$I_Z = 100\mu\text{A}$	1.225			1.225			V	
	Reverse breakdown voltage tolerance	$I_Z = 100\mu\text{A}$	25°C	-6		6		-12	12	mV
			Full range	-18.4		18.4		-31	31	
$I_{Z,\text{min}}$	Minimum cathode current		25°C	45		75		45	75	μA
			Full range			80			80	
α_{VZ}	Average temperature coefficient of reverse breakdown voltage	$I_Z = 10\text{mA}$	25°C	± 20		± 20		ppm/°C		
		$I_Z = 1\text{mA}$	25°C	± 15		± 15				
			Full range	± 100		± 150				
		$I_Z = 100\mu\text{A}$	25°C	± 15		± 15				
$\Delta V_Z/\Delta I_Z$	Reverse breakdown voltage change with cathode current change	$I_{Z,\text{min}} < I_Z < 1\text{mA}$	25°C	0.7		1.5		0.7	2	mV
			Full range			2			2.5	
		$1\text{mA} < I_Z < 12\text{mA}$	25°C	2.5		6		2.5	8	
			Full range			8			10	
Z_Z	Reverse dynamic impedance	$I_Z = 1\text{mA}$, $f = 120\text{Hz}$, $I_{AC} = 0.1 I_Z$	25°C	0.5		0.5		Ω		
			Full range			1.5			2	
e_N	Wideband noise	$I_Z = 100\mu\text{A}$, $10\text{Hz} \leq f \leq 10\text{kHz}$	25°C	20		20		μV_{RMS}		
	Long-term stability of reverse breakdown voltage	$t = 1000\text{h}$, $T_A = 25^\circ\text{C} \pm 0.1^\circ\text{C}$, $I_Z = 100\mu\text{A}$	25°C	120		120		ppm		

6.6 LM4041xl (Adjustable Version) Electrical Characteristics

full-range $T_A = -40^\circ\text{C}$ to 85°C (unless otherwise noted)

PARAMETER	TEST CONDITIONS	T_A	LM4041BI			LM4041CI			UNIT
			MIN	TYP	MAX	MIN	TYP	MAX	
V_{REF}	Reference voltage	$I_Z = 100\mu\text{A}$, $V_Z = 5\text{V}$	25°C			1.233			V
	Reference voltage tolerance ⁽¹⁾	$I_Z = 100\mu\text{A}$, $V_Z = 5\text{V}$	25°C			-2.5 2.5			mV
			Full range			-10.5 10.5			
$I_{Z,min}$	Minimum cathode current		25°C			45 75			μA
			Full range			80 80			
$\Delta V_{REF}/\Delta I_Z$	Reference voltage change with cathode current change	$I_{Z,min} < I_Z < 1\text{mA}$	25°C			0.7 1.5			mV
			Full range			2 2			
		$1\text{mA} < I_Z < 12\text{mA}$	25°C			2 4			
			Full range			6 6			
$\Delta V_{REF}/\Delta V_{KA}$	Reference voltage change with output voltage change	$I_Z = 1\text{mA}$	25°C			-1.55 -2			mV/V
			Full range			-2.5 -2.5			
I_{FB}	Feedback current		25°C			60 100			nA
			Full range			120 120			
αV_{REF}	Average temperature coefficient of reference voltage ⁽¹⁾	$I_Z = 10\text{mA}$, $V_Z = 5\text{V}$	25°C			± 20			ppm/°C
		$I_Z = 1\text{mA}$, $V_Z = 5\text{V}$	25°C			± 15			
			Full range			± 100			
		$I_Z = 100\mu\text{A}$, $V_Z = 5\text{V}$	25°C			± 15			
Z_Z	Reverse dynamic impedance	$I_Z = 1\text{mA}$, $f = 120\text{Hz}$, $I_{AC} = 0.1 I_Z$, $V_Z = V_{REF}$	25°C			0.3			Ω
		$I_Z = 1\text{mA}$, $f = 120\text{Hz}$, $I_{AC} = 0.1 I_Z$, $V_Z = 10\text{V}$	25°C			2			
e_N	Wideband noise	$I_Z = 100\mu\text{A}$, $V_Z = V_{REF}$, $10\text{Hz} \leq f \leq 10\text{kHz}$	25°C			20			μV_{RMS}
	Long-term stability of reverse breakdown voltage	$t = 1000\text{ h}$, $T_A = 25^\circ\text{C} \pm 0.1^\circ\text{C}$, $I_Z = 100\mu\text{A}$	25°C			120			ppm

(1) Reference voltage tolerance and average temperature coefficient change with output voltage (V_Z). See *Typical Characteristics*.

6.7 LM4041xl (Adjustable Version) Electrical Characteristics

full-range $T_A = -40^\circ\text{C}$ to 85°C (unless otherwise noted)

PARAMETER	TEST CONDITIONS	T_A	LM4041DI			UNIT
			MIN	TYP	MAX	
V_{REF}	Reference voltage	$I_Z = 100\mu\text{A}$, $V_Z = 5\text{V}$	25°C	1.233		V
	Reference voltage tolerance ⁽¹⁾	$I_Z = 100\mu\text{A}$, $V_Z = 5\text{V}$	25°C	-12	12	mV
			Full range	-24	24	
$I_{Z,min}$	Minimum cathode current		25°C	45	75	μA
			Full range		80	
$\Delta V_{REF}/\Delta I_Z$	Reference voltage change with cathode current change	$I_{Z,min} < I_Z < 1\text{mA}$	25°C	0.7	2	mV
			Full range		2.5	
		$1\text{mA} < I_Z < 12\text{mA}$	25°C	2	6	
			Full range		8	
$\Delta V_{REF}/\Delta V_{KA}$	Reference voltage change with output voltage change	$I_Z = 1\text{mA}$	25°C	-1.55	-2	mV/V
			Full range		-3	
I_{FB}	Feedback current		25°C	60	150	nA
			Full range		200	
αV_{REF}	Average temperature coefficient of reference voltage ⁽¹⁾	$I_Z = 10\text{mA}$, $V_Z = 5\text{V}$	25°C	± 20	ppm/ $^\circ\text{C}$	
			25°C	± 15		
		$I_Z = 1\text{mA}$, $V_Z = 5\text{V}$	Full range	± 150		
			25°C	± 15		
Z_Z	Reverse dynamic impedance	$I_Z = 1\text{mA}$, $f = 120\text{Hz}$, $I_{AC} = 0.1 I_Z$, $V_Z = V_{REF}$	25°C	0.3	Ω	
			25°C	2		
e_N	Wideband noise	$I_Z = 100\mu\text{A}$, $V_Z = V_{REF}$, $10\text{Hz} \leq f \leq 10\text{kHz}$	25°C	20	μV_{RMS}	
	Long-term stability of reverse breakdown voltage	$t = 1000\text{ h}$, $T_A = 25^\circ\text{C} \pm 0.1^\circ\text{C}$, $I_Z = 100\mu\text{A}$	25°C	120	ppm	

(1) Reference voltage tolerance and average temperature coefficient change with output voltage (V_Z). See *Typical Characteristics*.

6.8 LM4041xQ (Adjustable Version) Electrical Characteristics

full-range $T_A = -40^\circ\text{C}$ to 125°C (unless otherwise noted)

PARAMETER	TEST CONDITIONS	T_A	LM4041CQ			LM4041DQ			UNIT
			MIN	TYP	MAX	MIN	TYP	MAX	
V_{REF}	Reference voltage	$I_Z = 100\mu\text{A}$, $V_Z = 5\text{V}$	25°C			1.233			V
	Reference voltage tolerance ⁽¹⁾	$I_Z = 100\mu\text{A}$, $V_Z = 5\text{V}$	25°C			-6.2 6.2			mV
			Full range			-18 18			
$I_{Z,min}$	Minimum cathode current		25°C			45 75			μA
			Full range			80 80			
$\Delta V_{REF}/\Delta I_Z$	Reference voltage change with cathode current change	$I_{Z,min} < I_Z < 1\text{mA}$	25°C			0.7 1.5			mV
			Full range			2 2.5			
		$1\text{mA} < I_Z < 12\text{mA}$	25°C			2 4			
			Full range			8 10			
$\Delta V_{REF}/\Delta V_{KA}$	Reference voltage change with output voltage change	$I_Z = 1\text{mA}$	25°C			-1.55 -2			mV/V
			Full range			-3 -4			
I_{FB}	Feedback current		25°C			60 100			nA
			Full range			120 200			
αV_{REF}	Average temperature coefficient of reference voltage ⁽¹⁾	$I_Z = 10\text{mA}$, $V_Z = 5\text{V}$	25°C			± 20			ppm/°C
			25°C			± 15			
		$I_Z = 1\text{mA}$, $V_Z = 5\text{V}$	Full range			± 100			
			25°C			± 15			
Z_Z	Reverse dynamic impedance	$I_Z = 1\text{mA}$, $f = 120\text{Hz}$, $I_{AC} = 0.1 I_Z$, $V_Z = V_{REF}$	25°C			0.3			Ω
		$I_Z = 1\text{mA}$, $f = 120\text{Hz}$, $I_{AC} = 0.1 I_Z$, $V_Z = 10\text{V}$	25°C			2			
e_N	Wideband noise	$I_Z = 100\mu\text{A}$, $V_Z = V_{REF}$, $10\text{Hz} \leq f \leq 10\text{kHz}$	25°C			20			μV_{RMS}
	Long-term stability of reverse breakdown voltage	$t = 1000\text{ h}$, $T_A = 25^\circ\text{C} \pm 0.1^\circ\text{C}$, $I_Z = 100\mu\text{A}$	25°C			120			ppm

(1) Reference voltage tolerance and average temperature coefficient change with output voltage (V_Z). See *Typical Characteristics*.

6.9 Typical Characteristics

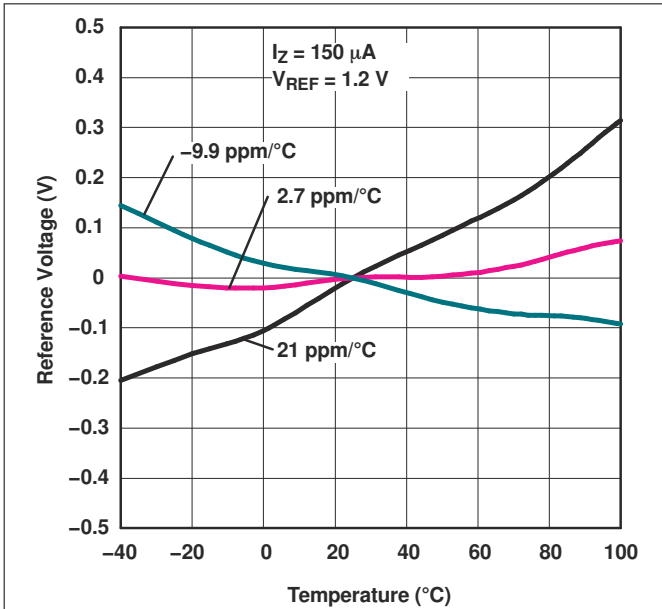

Figure 6-1. Temperature Drift for Different Average Temperature Coefficients

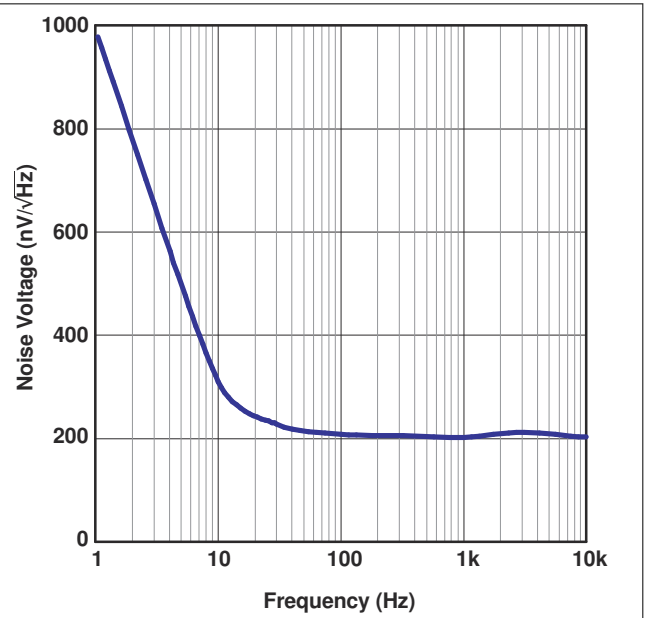

Figure 6-2. Noise Voltage vs Frequency

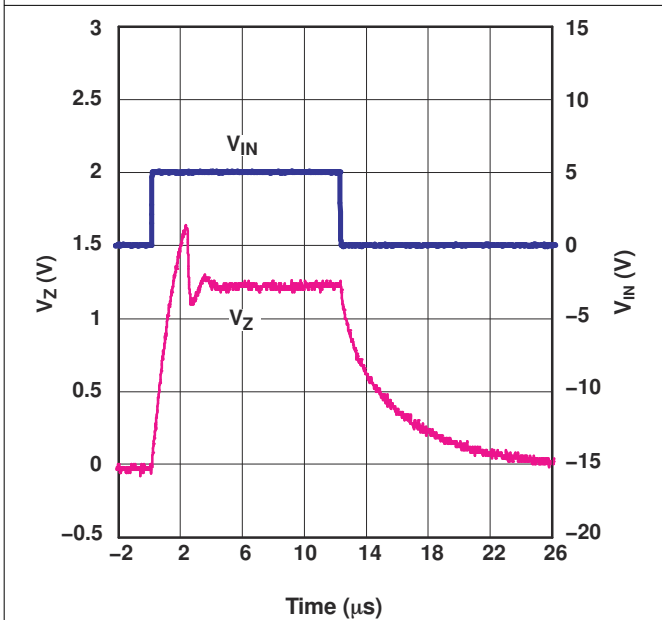

Figure 6-3. Start-Up Characteristics

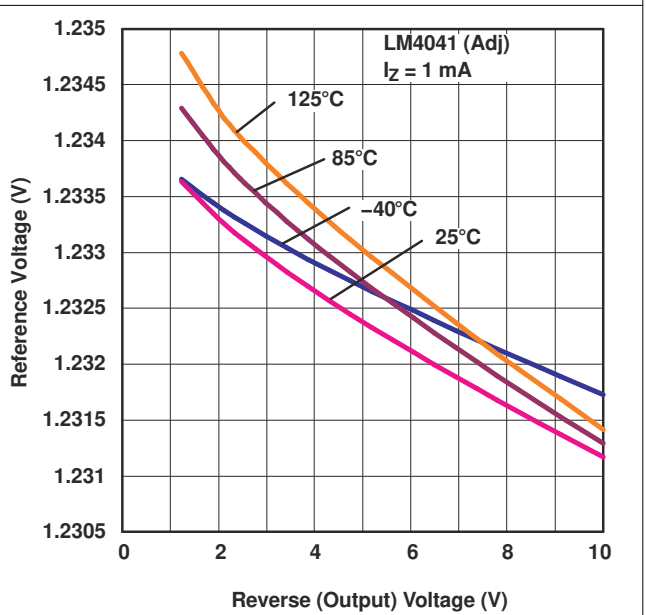

Figure 6-4. Reference Voltage vs Reverse (Output) Voltage (for Different Temperatures)

6.9 Typical Characteristics (continued)

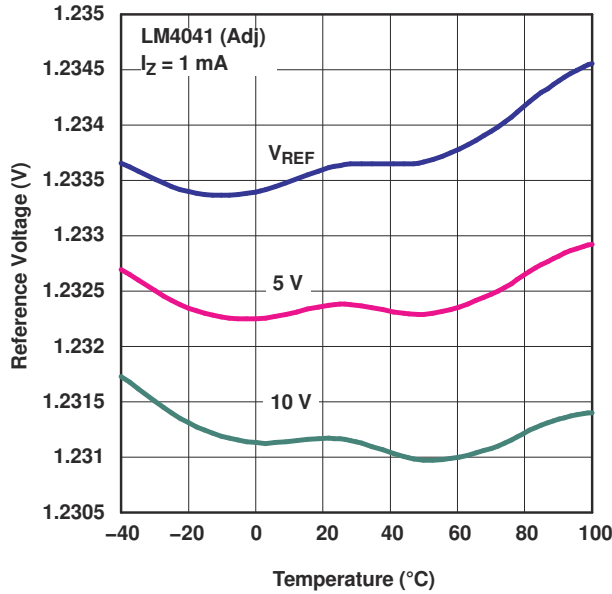

Figure 6-5. Reference Voltage vs Temperature (for Different Reverse Voltages)

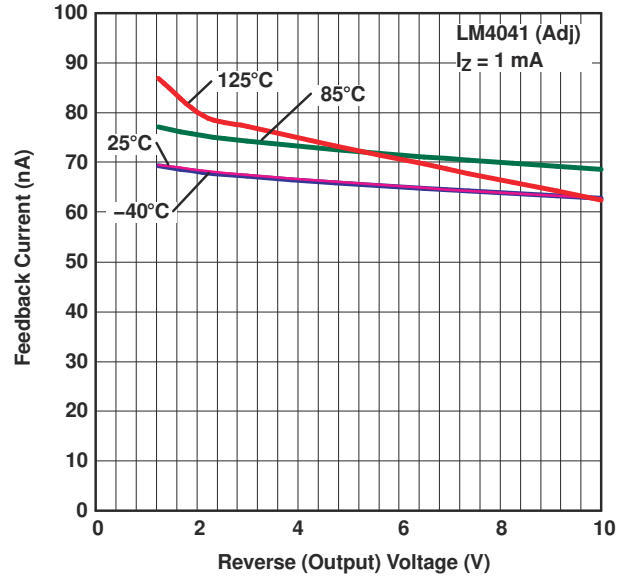

Figure 6-6. Feedback Current vs Reverse (Output) Voltage (for Different Temperatures)

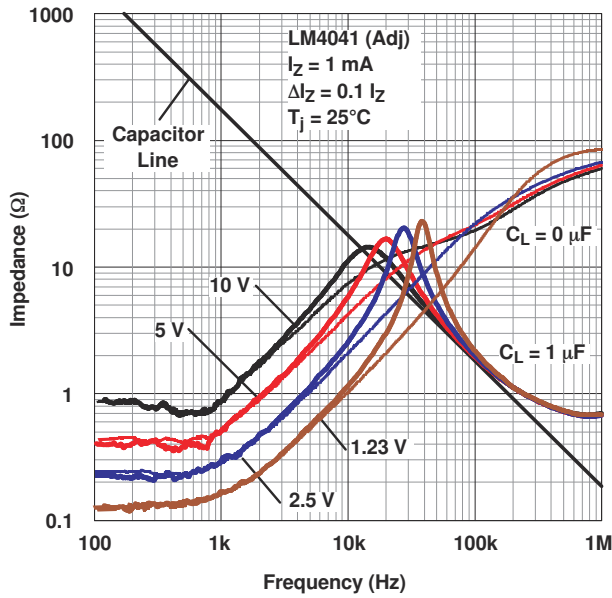

Figure 6-7. Output Impedance vs Frequency

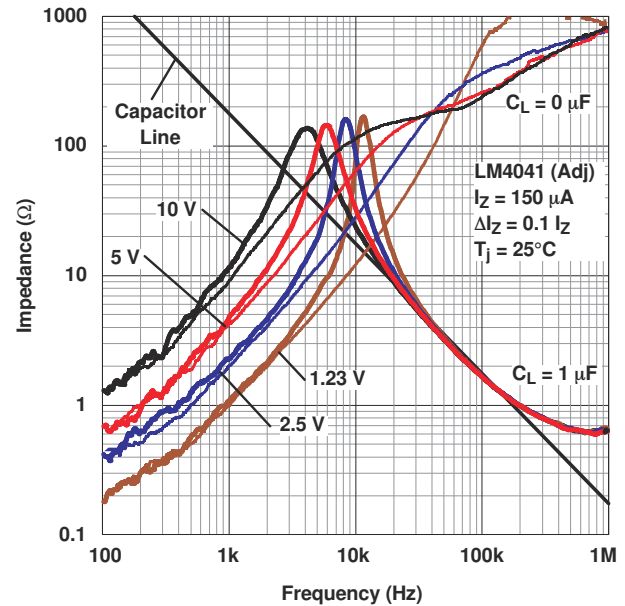
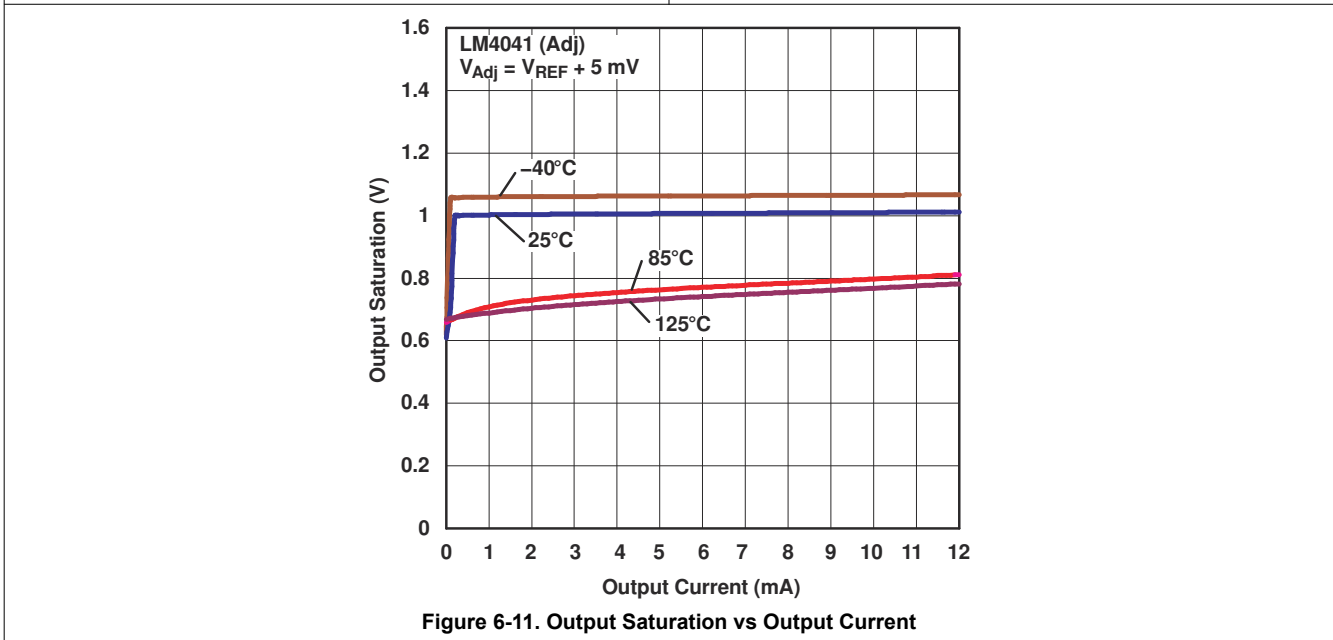
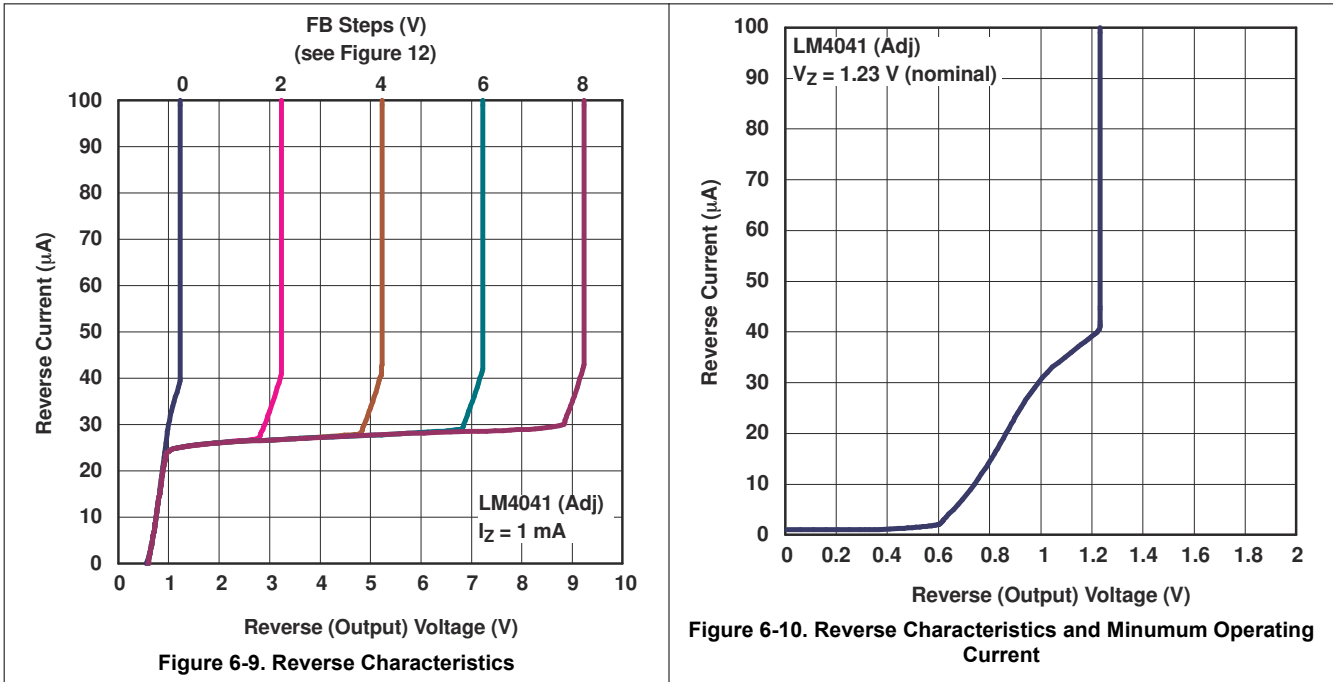

Figure 6-8. Output Impedance vs Frequency

6.9 Typical Characteristics (continued)



7 Application Information

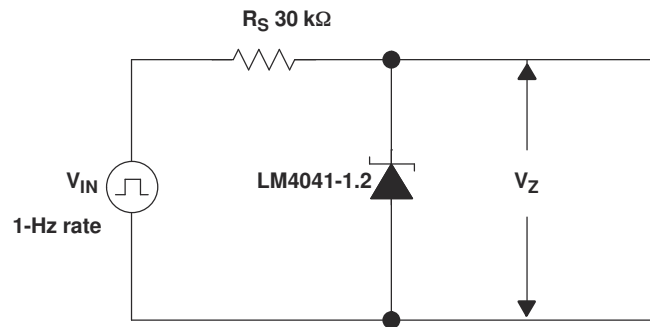

Figure 7-1. Startup Characteristics Test Circuit

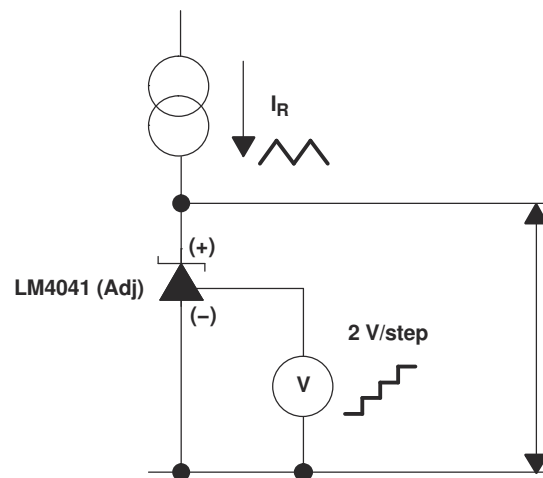

Figure 7-2. Reverse Characteristics Test Circuit

7.1 Output Capacitor

The LM4041 does not require an output capacitor across CATHODE and ANODE for stability. However, if an output bypass capacitor is desired, the LM4041 is designed to be stable with all capacitive loads.

7.2 SOT-23 and SC-70 Pin Connections

There is a parasitic Schottky diode connected between pins 2 and 3 of the SOT-23 packaged device. Thus, pin 3 of the SOT-23 package must be left floating or connected to pin 2. Similarly, pin 2 of the SC-70 package also must be left floating or connected to pin 1.

7.3 Adjustable Version

The adjustable version allows V_Z to be set by a user-defined resistor divider. The output voltage, V_Z , is set according to the equation shown in Figure 7-3.

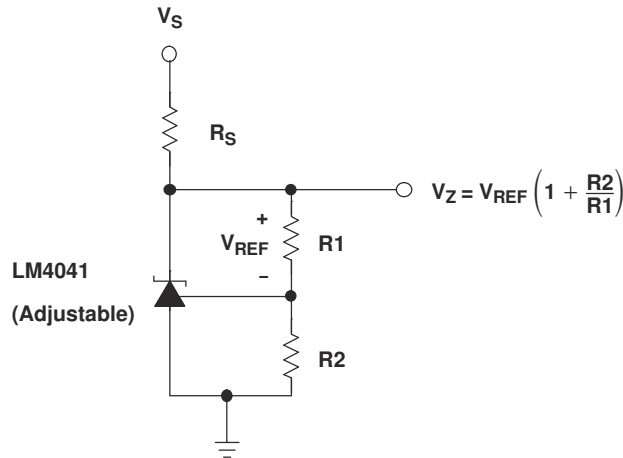

Figure 7-3. Adjustable Shunt Regulator

7.4 Cathode and Load Currents

In a typical shunt regulator configuration (see Figure 7-4), an external resistor, R_S , is connected between the supply and the cathode of the LM4041. R_S must be set properly, this sets the total current available to supply the load (I_L) and bias the LM4041 (I_Z). In all cases, I_Z must stay within a specified range for proper operation of the reference. Taking into consideration one extreme in the variation of the load and supply voltage (maximum I_L and minimum V_S), R_S must be small enough to supply the minimum I_Z required for operation of the regulator, as given by data sheet parameters. At the other extreme, maximum V_S and minimum I_L , R_S must be large enough to limit I_Z to less than the maximum recommended rating of 12mA.

R_S is calculated as shown in Equation 1.

$$R_S = \frac{(V_S - V_Z)}{(I_L + I_Z)} \quad (1)$$

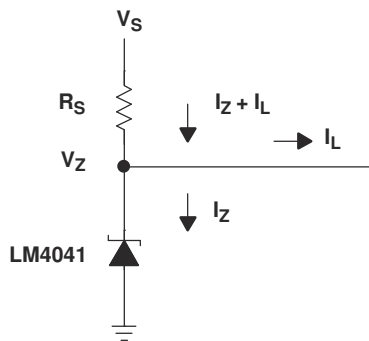

Figure 7-4. Shunt Regulator

8 Device and Documentation Support

8.1 Receiving Notification of Documentation Updates

To receive notification of documentation updates, navigate to the device product folder on ti.com. Click on *Notifications* to register and receive a weekly digest of any product information that has changed. For change details, review the revision history included in any revised document.

8.2 Trademarks

TI E2E™ is a trademark of Texas Instruments.

All trademarks are the property of their respective owners.

8.3 Electrostatic Discharge Caution



This integrated circuit can be damaged by ESD. Texas Instruments recommends that all integrated circuits be handled with appropriate precautions. Failure to observe proper handling and installation procedures can cause damage.

ESD damage can range from subtle performance degradation to complete device failure. Precision integrated circuits may be more susceptible to damage because very small parametric changes could cause the device not to meet its published specifications.

8.4 Support Resources

[TI E2E™ support forums](#) are an engineer's go-to source for fast, verified answers and design help — straight from the experts. Search existing answers or ask your own question to get the quick design help you need.

Linked content is provided "AS IS" by the respective contributors. They do not constitute TI specifications and do not necessarily reflect TI's views; see TI's [Terms of Use](#).

8.5 Glossary

[TI Glossary](#) This glossary lists and explains terms, acronyms, and definitions.

9 Revision History

NOTE: Page numbers for previous revisions may differ from page numbers in the current version.

Changes from Revision F (September 2020) to Revision G (July 2024)	Page
• Updated <i>Applications</i> links.....	1
• Updated pinout diagrams	2

Changes from Revision E (February 2006) to Revision F (September 2020)**Page**

- Updated the numbering format for tables, figures and cross-references throughout the document..... 1
 - Deleted *Ordering Information* table. See Mechanical, Packaging, and Orderable Information at the end of the data sheet.....4
-

10 Mechanical, Packaging, and Orderable Information

The following pages include mechanical, packaging, and orderable information. This information is the most current data available for the designated devices. This data is subject to change without notice and revision of this document. For browser-based versions of this data sheet, refer to the left-hand navigation.

PACKAGING INFORMATION

Orderable Device	Status (1)	Package Type	Package Drawing	Pins	Package Qty	Eco Plan (2)	Lead finish/ Ball material (6)	MSL Peak Temp (3)	Op Temp (°C)	Device Marking (4/5)	Samples
LM4041A12IDBZR	ACTIVE	SOT-23	DBZ	3	3000	RoHS & Green	NIPDAU SN	Level-1-260C-UNLIM	-40 to 85	(4MK3, 4MKU)	Samples
LM4041A12IDBZT	ACTIVE	SOT-23	DBZ	3	250	RoHS & Green	NIPDAU	Level-1-260C-UNLIM	-40 to 85	(4MK3, 4MKU)	Samples
LM4041A12IDCKR	ACTIVE	SC70	DCK	5	3000	RoHS & Green	NIPDAU	Level-1-260C-UNLIM	-40 to 85	MKU	Samples
LM4041B12IDBZR	ACTIVE	SOT-23	DBZ	3	3000	RoHS & Green	NIPDAU	Level-1-260C-UNLIM	-40 to 85	(4ML3, 4MLU)	Samples
LM4041B12IDBZT	ACTIVE	SOT-23	DBZ	3	250	RoHS & Green	NIPDAU	Level-1-260C-UNLIM	-40 to 85	(4ML3, 4MLU)	Samples
LM4041B12IDCKR	ACTIVE	SC70	DCK	5	3000	RoHS & Green	NIPDAU	Level-1-260C-UNLIM	-40 to 85	MLU	Samples
LM4041BIDBZR	ACTIVE	SOT-23	DBZ	3	3000	RoHS & Green	NIPDAU	Level-1-260C-UNLIM	-40 to 85	(4MG3, 4MGU)	Samples
LM4041BIDBZR1G4	ACTIVE	SOT-23	DBZ	3	3000	RoHS & Green	NIPDAU	Level-1-260C-UNLIM		(4MG3, 4MGU)	Samples
LM4041BIDBZT	ACTIVE	SOT-23	DBZ	3	250	RoHS & Green	NIPDAU	Level-1-260C-UNLIM	-40 to 85	(4MG3, 4MGU)	Samples
LM4041BIDCKR	ACTIVE	SC70	DCK	5	3000	RoHS & Green	NIPDAU	Level-1-260C-UNLIM	-40 to 85	MGU	Samples
LM4041BIDCKT	ACTIVE	SC70	DCK	5	250	RoHS & Green	NIPDAU	Level-1-260C-UNLIM	-40 to 85	MGU	Samples
LM4041C12IDBZR	ACTIVE	SOT-23	DBZ	3	3000	RoHS & Green	NIPDAU	Level-1-260C-UNLIM	-40 to 85	(4MM3, 4MMU)	Samples
LM4041C12IDBZT	ACTIVE	SOT-23	DBZ	3	250	RoHS & Green	NIPDAU	Level-1-260C-UNLIM	-40 to 85	(4MM3, 4MMU)	Samples
LM4041C12IDCKR	ACTIVE	SC70	DCK	5	3000	RoHS & Green	NIPDAU	Level-1-260C-UNLIM	-40 to 85	MMU	Samples
LM4041C12IDCKRE4	ACTIVE	SC70	DCK	5	3000	TBD	Call TI	Call TI	-40 to 85		Samples
LM4041C12IDCKRG4	ACTIVE	SC70	DCK	5	3000	TBD	Call TI	Call TI	-40 to 85		Samples
LM4041C12ILP	ACTIVE	TO-92	LP	3	1000	RoHS & Green	SN	N / A for Pkg Type	-40 to 85	NPC12I	Samples
LM4041C12ILPR	ACTIVE	TO-92	LP	3	2000	RoHS & Green	SN	N / A for Pkg Type	-40 to 85	NPC12I	Samples
LM4041C12QDBZR	ACTIVE	SOT-23	DBZ	3	3000	RoHS & Green	NIPDAU	Level-1-260C-UNLIM	-40 to 125	(4MS3, 4MSU)	Samples
LM4041C12QDBZT	ACTIVE	SOT-23	DBZ	3	250	RoHS & Green	NIPDAU	Level-1-260C-UNLIM	-40 to 125	(4MS3, 4MSU)	Samples

Orderable Device	Status (1)	Package Type	Package Drawing	Pins	Package Qty	Eco Plan (2)	Lead finish/ Ball material (6)	MSL Peak Temp (3)	Op Temp (°C)	Device Marking (4/5)	Samples
LM4041CIDBZR	ACTIVE	SOT-23	DBZ	3	3000	RoHS & Green	NIPDAU	Level-1-260C-UNLIM	-40 to 85	(4MH3, 4MHU)	Samples
LM4041CIDBZT	ACTIVE	SOT-23	DBZ	3	250	RoHS & Green	NIPDAU	Level-1-260C-UNLIM	-40 to 85	(4MH3, 4MHU)	Samples
LM4041CIDCKR	ACTIVE	SC70	DCK	5	3000	RoHS & Green	NIPDAU	Level-1-260C-UNLIM	-40 to 85	MHU	Samples
LM4041CIDCKT	ACTIVE	SC70	DCK	5	250	RoHS & Green	NIPDAU	Level-1-260C-UNLIM	-40 to 85	MHU	Samples
LM4041CILP	OBSOLETE	TO-92	LP	3		TBD	Call TI	Call TI	-40 to 85	NPCI	
LM4041CILPE3	NRND	TO-92	LP	3	1000	TBD	Call TI	Call TI	-40 to 85		
LM4041CILPR	ACTIVE	TO-92	LP	3	2000	RoHS & Green	SN	N / A for Pkg Type	-40 to 85	NPCI	Samples
LM4041CQDBZR	ACTIVE	SOT-23	DBZ	3	3000	RoHS & Green	NIPDAU	Level-1-260C-UNLIM	-40 to 125	(4MP3, 4MPU)	Samples
LM4041CQDBZT	ACTIVE	SOT-23	DBZ	3	250	RoHS & Green	NIPDAU	Level-1-260C-UNLIM	-40 to 125	(4MP3, 4MPU)	Samples
LM4041D12IDBZR	ACTIVE	SOT-23	DBZ	3	3000	RoHS & Green	NIPDAU	Level-1-260C-UNLIM	-40 to 85	(4MN3, 4MNU)	Samples
LM4041D12IDBZT	ACTIVE	SOT-23	DBZ	3	250	RoHS & Green	NIPDAU	Level-1-260C-UNLIM	-40 to 85	(4MN3, 4MNU)	Samples
LM4041D12IDCKR	ACTIVE	SC70	DCK	5	3000	RoHS & Green	NIPDAU	Level-1-260C-UNLIM	-40 to 85	MNU	Samples
LM4041D12ILP	ACTIVE	TO-92	LP	3	1000	RoHS & Green	SN	N / A for Pkg Type	-40 to 85	NPD12I	Samples
LM4041D12ILPE3	ACTIVE	TO-92	LP	3	1000	TBD	Call TI	Call TI	-40 to 85		Samples
LM4041D12ILPR	ACTIVE	TO-92	LP	3	2000	RoHS & Green	SN	N / A for Pkg Type	-40 to 85	NPD12I	Samples
LM4041D12QDBZR	ACTIVE	SOT-23	DBZ	3	3000	RoHS & Green	NIPDAU	Level-1-260C-UNLIM	-40 to 125	(4MT3, 4MTU)	Samples
LM4041DIDBZR	ACTIVE	SOT-23	DBZ	3	3000	RoHS & Green	NIPDAU	Level-1-260C-UNLIM	-40 to 85	(4MJ3, 4MJU)	Samples
LM4041DIDBZT	ACTIVE	SOT-23	DBZ	3	250	RoHS & Green	NIPDAU	Level-1-260C-UNLIM	-40 to 85	(4MJ3, 4MJU)	Samples
LM4041DIDCKR	ACTIVE	SC70	DCK	5	3000	RoHS & Green	NIPDAU	Level-1-260C-UNLIM	-40 to 85	MJU	Samples
LM4041DIDCKRG4	ACTIVE	SC70	DCK	5	3000	RoHS & Green	NIPDAU	Level-1-260C-UNLIM	-40 to 85	MJU	Samples
LM4041DILP	OBSOLETE	TO-92	LP	3		TBD	Call TI	Call TI	-40 to 85	NPDI	
LM4041DILPR	ACTIVE	TO-92	LP	3	2000	RoHS & Green	SN	N / A for Pkg Type	-40 to 85	NPDI	Samples

Orderable Device	Status (1)	Package Type	Package Drawing	Pins	Package Qty	Eco Plan (2)	Lead finish/ Ball material (6)	MSL Peak Temp (3)	Op Temp (°C)	Device Marking (4/5)	Samples
LM4041DQDBZR	ACTIVE	SOT-23	DBZ	3	3000	RoHS & Green	NIPDAU	Level-1-260C-UNLIM	-40 to 125	(4MR3, 4MRU)	Samples
LM4041DQDBZT	ACTIVE	SOT-23	DBZ	3	250	RoHS & Green	NIPDAU	Level-1-260C-UNLIM	-40 to 125	(4MR3, 4MRU)	Samples

(1) The marketing status values are defined as follows:

ACTIVE: Product device recommended for new designs.

LIFEBUY: TI has announced that the device will be discontinued, and a lifetime-buy period is in effect.

NRND: Not recommended for new designs. Device is in production to support existing customers, but TI does not recommend using this part in a new design.

PREVIEW: Device has been announced but is not in production. Samples may or may not be available.

OBSOLETE: TI has discontinued the production of the device.

(2) **RoHS:** TI defines "RoHS" to mean semiconductor products that are compliant with the current EU RoHS requirements for all 10 RoHS substances, including the requirement that RoHS substance do not exceed 0.1% by weight in homogeneous materials. Where designed to be soldered at high temperatures, "RoHS" products are suitable for use in specified lead-free processes. TI may reference these types of products as "Pb-Free".

RoHS Exempt: TI defines "RoHS Exempt" to mean products that contain lead but are compliant with EU RoHS pursuant to a specific EU RoHS exemption.

Green: TI defines "Green" to mean the content of Chlorine (Cl) and Bromine (Br) based flame retardants meet JS709B low halogen requirements of <=1000ppm threshold. Antimony trioxide based flame retardants must also meet the <=1000ppm threshold requirement.

(3) **MSL, Peak Temp.** - The Moisture Sensitivity Level rating according to the JEDEC industry standard classifications, and peak solder temperature.

(4) There may be additional marking, which relates to the logo, the lot trace code information, or the environmental category on the device.

(5) Multiple Device Markings will be inside parentheses. Only one Device Marking contained in parentheses and separated by a "~" will appear on a device. If a line is indented then it is a continuation of the previous line and the two combined represent the entire Device Marking for that device.

(6) **Lead finish/Ball material** - Orderable Devices may have multiple material finish options. Finish options are separated by a vertical ruled line. Lead finish/Ball material values may wrap to two lines if the finish value exceeds the maximum column width.

Important Information and Disclaimer:The information provided on this page represents TI's knowledge and belief as of the date that it is provided. TI bases its knowledge and belief on information provided by third parties, and makes no representation or warranty as to the accuracy of such information. Efforts are underway to better integrate information from third parties. TI has taken and continues to take reasonable steps to provide representative and accurate information but may not have conducted destructive testing or chemical analysis on incoming materials and chemicals. TI and TI suppliers consider certain information to be proprietary, and thus CAS numbers and other limited information may not be available for release.

In no event shall TI's liability arising out of such information exceed the total purchase price of the TI part(s) at issue in this document sold by TI to Customer on an annual basis.

TAPE AND REEL INFORMATION

QUADRANT ASSIGNMENTS FOR PIN 1 ORIENTATION IN TAPE

*All dimensions are nominal

Device	Package Type	Package Drawing	Pins	SPQ	Reel Diameter (mm)	Reel Width W1 (mm)	A0 (mm)	B0 (mm)	K0 (mm)	P1 (mm)	W (mm)	Pin1 Quadrant
LM4041A12IDBZR	SOT-23	DBZ	3	3000	180.0	8.4	2.9	3.35	1.35	4.0	8.0	Q3
LM4041A12IDBZT	SOT-23	DBZ	3	250	180.0	8.4	2.9	3.35	1.35	4.0	8.0	Q3
LM4041A12IDCKR	SC70	DCK	5	3000	179.0	8.4	2.2	2.5	1.2	4.0	8.0	Q3
LM4041B12IDBZR	SOT-23	DBZ	3	3000	180.0	8.4	2.9	3.35	1.35	4.0	8.0	Q3
LM4041B12IDBZT	SOT-23	DBZ	3	250	180.0	8.4	2.9	3.35	1.35	4.0	8.0	Q3
LM4041B12IDCKR	SC70	DCK	5	3000	179.0	8.4	2.2	2.5	1.2	4.0	8.0	Q3
LM4041BIDBZR	SOT-23	DBZ	3	3000	179.0	8.4	3.15	2.95	1.22	4.0	8.0	Q3
LM4041BIDBZT	SOT-23	DBZ	3	3000	178.0	9.2	3.15	2.77	1.22	4.0	8.0	Q3
LM4041BIDBZR1G4	SOT-23	DBZ	3	3000	178.0	9.2	3.15	2.77	1.22	4.0	8.0	Q3
LM4041BIDBZR1G4	SOT-23	DBZ	3	3000	179.0	8.4	3.15	2.95	1.22	4.0	8.0	Q3
LM4041BIDBZT	SOT-23	DBZ	3	250	179.0	8.4	3.15	2.95	1.22	4.0	8.0	Q3
LM4041BIDBZT	SOT-23	DBZ	3	250	178.0	9.2	3.15	2.77	1.22	4.0	8.0	Q3
LM4041BIDCKR	SC70	DCK	5	3000	179.0	8.4	2.2	2.5	1.2	4.0	8.0	Q3
LM4041BIDCKT	SC70	DCK	5	250	179.0	8.4	2.2	2.5	1.2	4.0	8.0	Q3
LM4041C12IDBZR	SOT-23	DBZ	3	3000	180.0	8.4	2.9	3.35	1.35	4.0	8.0	Q3
LM4041C12IDBZT	SOT-23	DBZ	3	250	180.0	8.4	2.9	3.35	1.35	4.0	8.0	Q3

Device	Package Type	Package Drawing	Pins	SPQ	Reel Diameter (mm)	Reel Width W1 (mm)	A0 (mm)	B0 (mm)	K0 (mm)	P1 (mm)	W (mm)	Pin1 Quadrant
LM4041C12IDCKR	SC70	DCK	5	3000	179.0	8.4	2.2	2.5	1.2	4.0	8.0	Q3
LM4041C12QDBZR	SOT-23	DBZ	3	3000	180.0	8.4	2.9	3.35	1.35	4.0	8.0	Q3
LM4041C12QDBZT	SOT-23	DBZ	3	250	180.0	8.4	2.9	3.35	1.35	4.0	8.0	Q3
LM4041CIDBZR	SOT-23	DBZ	3	3000	179.0	8.4	3.15	2.95	1.22	4.0	8.0	Q3
LM4041CIDBZR	SOT-23	DBZ	3	3000	178.0	9.2	3.15	2.77	1.22	4.0	8.0	Q3
LM4041CIDBZT	SOT-23	DBZ	3	250	179.0	8.4	3.15	2.95	1.22	4.0	8.0	Q3
LM4041CIDBZT	SOT-23	DBZ	3	250	178.0	9.2	3.15	2.77	1.22	4.0	8.0	Q3
LM4041CIDCKR	SC70	DCK	5	3000	179.0	8.4	2.2	2.5	1.2	4.0	8.0	Q3
LM4041CIDCKT	SC70	DCK	5	250	179.0	8.4	2.2	2.5	1.2	4.0	8.0	Q3
LM4041CQDBZR	SOT-23	DBZ	3	3000	178.0	9.2	3.15	2.77	1.22	4.0	8.0	Q3
LM4041CQDBZR	SOT-23	DBZ	3	3000	179.0	8.4	3.15	2.95	1.22	4.0	8.0	Q3
LM4041CQDBZT	SOT-23	DBZ	3	250	179.0	8.4	3.15	2.95	1.22	4.0	8.0	Q3
LM4041CQDBZT	SOT-23	DBZ	3	250	178.0	9.2	3.15	2.77	1.22	4.0	8.0	Q3
LM4041D12IDBZR	SOT-23	DBZ	3	3000	180.0	8.4	2.9	3.35	1.35	4.0	8.0	Q3
LM4041D12IDBZT	SOT-23	DBZ	3	250	180.0	8.4	2.9	3.35	1.35	4.0	8.0	Q3
LM4041D12IDCKR	SC70	DCK	5	3000	179.0	8.4	2.2	2.5	1.2	4.0	8.0	Q3
LM4041D12QDBZR	SOT-23	DBZ	3	3000	180.0	8.4	2.9	3.35	1.35	4.0	8.0	Q3
LM4041DIDBZR	SOT-23	DBZ	3	3000	179.0	8.4	3.15	2.95	1.22	4.0	8.0	Q3
LM4041DIDBZR	SOT-23	DBZ	3	3000	178.0	9.2	3.15	2.77	1.22	4.0	8.0	Q3
LM4041DIDBZT	SOT-23	DBZ	3	250	178.0	9.2	3.15	2.77	1.22	4.0	8.0	Q3
LM4041DIDCKR	SC70	DCK	5	3000	179.0	8.4	2.2	2.5	1.2	4.0	8.0	Q3
LM4041DIDCKRG4	SC70	DCK	5	3000	179.0	8.4	2.2	2.5	1.2	4.0	8.0	Q3
LM4041DQDBZR	SOT-23	DBZ	3	3000	178.0	9.2	3.15	2.77	1.22	4.0	8.0	Q3
LM4041DQDBZR	SOT-23	DBZ	3	3000	179.0	8.4	3.15	2.95	1.22	4.0	8.0	Q3
LM4041DQDBZT	SOT-23	DBZ	3	250	178.0	9.2	3.15	2.77	1.22	4.0	8.0	Q3
LM4041DQDBZT	SOT-23	DBZ	3	250	179.0	8.4	3.15	2.95	1.22	4.0	8.0	Q3

TAPE AND REEL BOX DIMENSIONS

*All dimensions are nominal

Device	Package Type	Package Drawing	Pins	SPQ	Length (mm)	Width (mm)	Height (mm)
LM4041A12IDBZR	SOT-23	DBZ	3	3000	210.0	185.0	35.0
LM4041A12IDBZT	SOT-23	DBZ	3	250	210.0	185.0	35.0
LM4041A12IDCKR	SC70	DCK	5	3000	200.0	183.0	25.0
LM4041B12IDBZR	SOT-23	DBZ	3	3000	210.0	185.0	35.0
LM4041B12IDBZT	SOT-23	DBZ	3	250	210.0	185.0	35.0
LM4041B12IDCKR	SC70	DCK	5	3000	200.0	183.0	25.0
LM4041BIDBZR	SOT-23	DBZ	3	3000	200.0	183.0	25.0
LM4041BIDBZT	SOT-23	DBZ	3	3000	180.0	180.0	18.0
LM4041BIDBZR1G4	SOT-23	DBZ	3	3000	180.0	180.0	18.0
LM4041BIDBZR1G4	SOT-23	DBZ	3	3000	200.0	183.0	25.0
LM4041BIDBZT	SOT-23	DBZ	3	250	200.0	183.0	25.0
LM4041BIDBZT	SOT-23	DBZ	3	250	180.0	180.0	18.0
LM4041BIDCKR	SC70	DCK	5	3000	200.0	183.0	25.0
LM4041BIDCKT	SC70	DCK	5	250	203.0	203.0	35.0
LM4041C12IDBZR	SOT-23	DBZ	3	3000	210.0	185.0	35.0
LM4041C12IDBZT	SOT-23	DBZ	3	250	210.0	185.0	35.0
LM4041C12IDCKR	SC70	DCK	5	3000	200.0	183.0	25.0
LM4041C12QDBZR	SOT-23	DBZ	3	3000	210.0	185.0	35.0

Device	Package Type	Package Drawing	Pins	SPQ	Length (mm)	Width (mm)	Height (mm)
LM4041C12QDBZT	SOT-23	DBZ	3	250	210.0	185.0	35.0
LM4041CIDBZR	SOT-23	DBZ	3	3000	200.0	183.0	25.0
LM4041CIDBZR	SOT-23	DBZ	3	3000	180.0	180.0	18.0
LM4041CIDBZT	SOT-23	DBZ	3	250	203.0	203.0	35.0
LM4041CIDBZT	SOT-23	DBZ	3	250	180.0	180.0	18.0
LM4041CIDCKR	SC70	DCK	5	3000	200.0	183.0	25.0
LM4041CIDCKT	SC70	DCK	5	250	200.0	183.0	25.0
LM4041CQDBZR	SOT-23	DBZ	3	3000	180.0	180.0	18.0
LM4041CQDBZR	SOT-23	DBZ	3	3000	200.0	183.0	25.0
LM4041CQDBZT	SOT-23	DBZ	3	250	200.0	183.0	25.0
LM4041CQDBZT	SOT-23	DBZ	3	250	180.0	180.0	18.0
LM4041D12IDBZR	SOT-23	DBZ	3	3000	210.0	185.0	35.0
LM4041D12IDBZT	SOT-23	DBZ	3	250	210.0	185.0	35.0
LM4041D12IDCKR	SC70	DCK	5	3000	200.0	183.0	25.0
LM4041D12QDBZR	SOT-23	DBZ	3	3000	210.0	185.0	35.0
LM4041DIDBZR	SOT-23	DBZ	3	3000	200.0	183.0	25.0
LM4041DIDBZR	SOT-23	DBZ	3	3000	180.0	180.0	18.0
LM4041DIDBZT	SOT-23	DBZ	3	250	180.0	180.0	18.0
LM4041DIDCKR	SC70	DCK	5	3000	200.0	183.0	25.0
LM4041DIDCKRG4	SC70	DCK	5	3000	200.0	183.0	25.0
LM4041DQDBZR	SOT-23	DBZ	3	3000	180.0	180.0	18.0
LM4041DQDBZR	SOT-23	DBZ	3	3000	200.0	183.0	25.0
LM4041DQDBZT	SOT-23	DBZ	3	250	180.0	180.0	18.0
LM4041DQDBZT	SOT-23	DBZ	3	250	203.0	203.0	35.0

DCK0005A



PACKAGE OUTLINE

SOT - 1.1 max height

SMALL OUTLINE TRANSISTOR

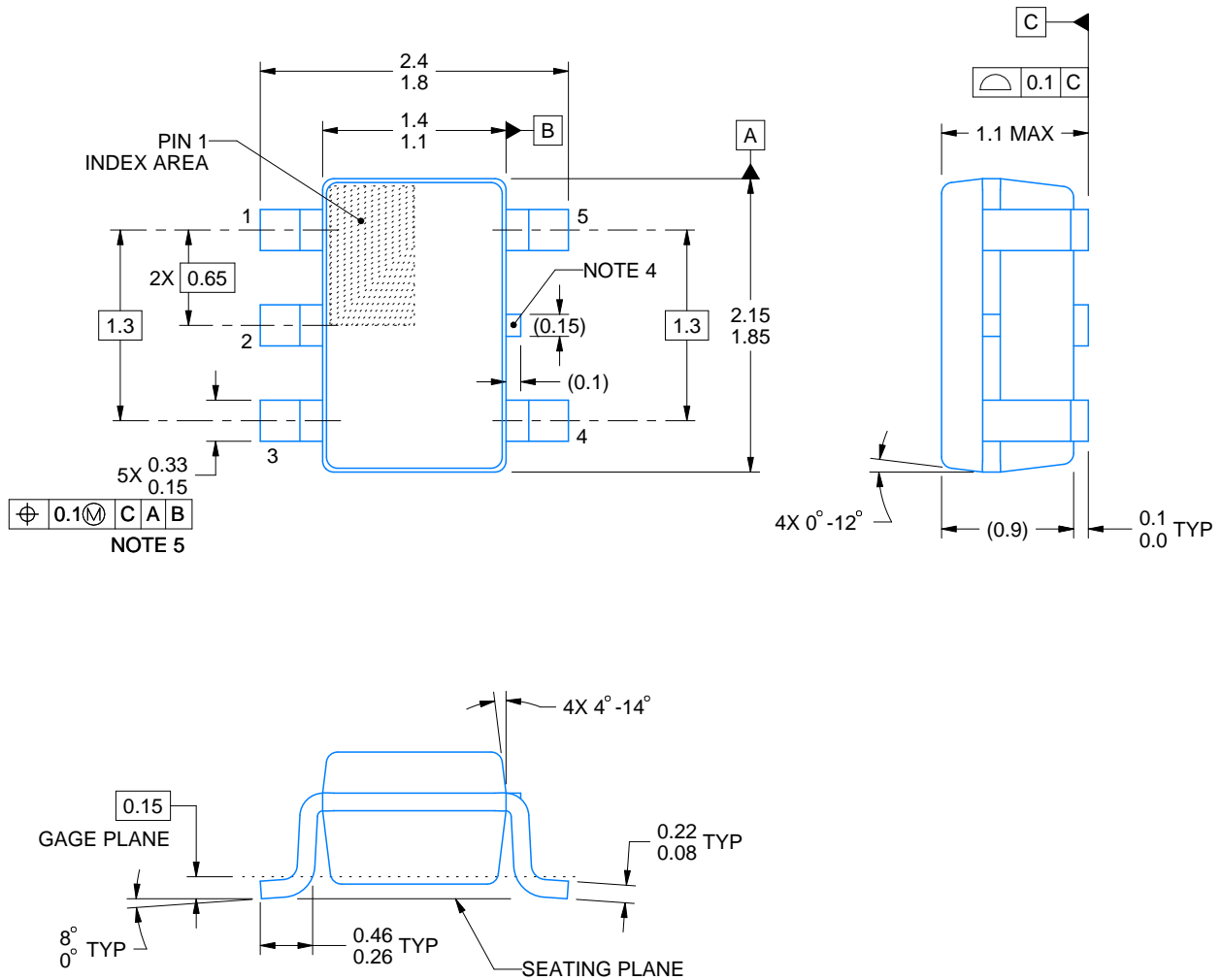

4214834/F 08/2024

NOTES:

1. All linear dimensions are in millimeters. Any dimensions in parenthesis are for reference only. Dimensioning and tolerancing per ASME Y14.5M.
2. This drawing is subject to change without notice.
3. Reference JEDEC MO-203.
4. Support pin may differ or may not be present.
5. Lead width does not comply with JEDEC.
6. Body dimensions do not include mold flash, protrusions, or gate burrs. Mold flash, protrusions, or gate burrs shall not exceed 0.25mm per side

EXAMPLE BOARD LAYOUT

DCK0005A

SOT - 1.1 max height

SMALL OUTLINE TRANSISTOR



LAND PATTERN EXAMPLE
EXPOSED METAL SHOWN
SCALE:18X



SOLDER MASK DETAILS

4214834/F 08/2024

NOTES: (continued)

- 7. Publication IPC-7351 may have alternate designs.
- 8. Solder mask tolerances between and around signal pads can vary based on board fabrication site.

EXAMPLE STENCIL DESIGN

DCK0005A

SOT - 1.1 max height

SMALL OUTLINE TRANSISTOR



SOLDER PASTE EXAMPLE
BASED ON 0.125 THICK STENCIL
SCALE: 18X

4214834/F 08/2024

NOTES: (continued)

9. Laser cutting apertures with trapezoidal walls and rounded corners may offer better paste release. IPC-7525 may have alternate design recommendations.
10. Board assembly site may have different recommendations for stencil design.

GENERIC PACKAGE VIEW

LP 3

TO-92 - 5.34 mm max height

TRANSISTOR OUTLINE



Images above are just a representation of the package family, actual package may vary.
Refer to the product data sheet for package details.

4040001-2/F

LP0003A



PACKAGE OUTLINE

TO-92 - 5.34 mm max height

TO-92



4215214/B 04/2017

NOTES:

1. All linear dimensions are in millimeters. Any dimensions in parenthesis are for reference only. Dimensioning and tolerancing per ASME Y14.5M.
2. This drawing is subject to change without notice.
3. Lead dimensions are not controlled within this area.
4. Reference JEDEC TO-226, variation AA.
5. Shipping method:
 - a. Straight lead option available in bulk pack only.
 - b. Formed lead option available in tape and reel or ammo pack.
 - c. Specific products can be offered in limited combinations of shipping medium and lead options.
 - d. Consult product folder for more information on available options.

EXAMPLE BOARD LAYOUT

LP0003A

TO-92 - 5.34 mm max height

TO-92



LAND PATTERN EXAMPLE
STRAIGHT LEAD OPTION
NON-SOLDER MASK DEFINED
SCALE:15X



LAND PATTERN EXAMPLE
FORMED LEAD OPTION
NON-SOLDER MASK DEFINED
SCALE:15X

4215214/B 04/2017

TAPE SPECIFICATIONS

LP0003A

TO-92 - 5.34 mm max height

TO-92



FOR FORMED LEAD OPTION PACKAGE

4215214/B 04/2017

DBZ0003A



PACKAGE OUTLINE SOT-23 - 1.12 mm max height

SMALL OUTLINE TRANSISTOR

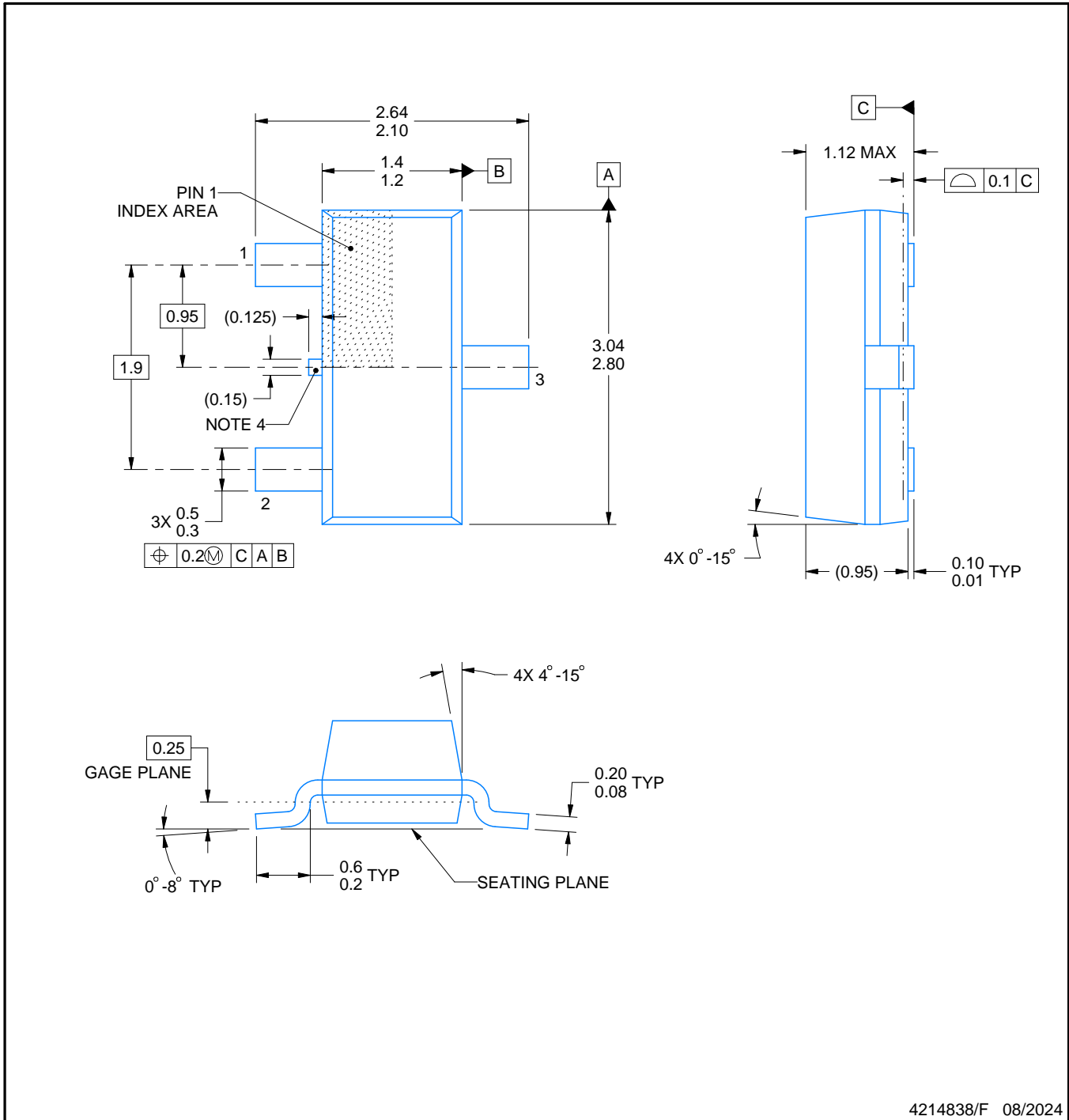

4214838/F 08/2024

NOTES:

1. All linear dimensions are in millimeters. Any dimensions in parenthesis are for reference only. Dimensioning and tolerancing per ASME Y14.5M.
2. This drawing is subject to change without notice.
3. Reference JEDEC registration TO-236, except minimum foot length.
4. Support pin may differ or may not be present.
5. Body dimensions do not include mold flash, protrusions, or gate burrs. Mold flash, protrusions, or gate burrs shall not exceed 0.25mm per side

EXAMPLE BOARD LAYOUT

DBZ0003A

SOT-23 - 1.12 mm max height

SMALL OUTLINE TRANSISTOR



LAND PATTERN EXAMPLE
SCALE:15X



SOLDER MASK DETAILS

4214838/F 08/2024

NOTES: (continued)

5. Publication IPC-7351 may have alternate designs.
6. Solder mask tolerances between and around signal pads can vary based on board fabrication site.

EXAMPLE STENCIL DESIGN

DBZ0003A

SOT-23 - 1.12 mm max height

SMALL OUTLINE TRANSISTOR



SOLDER PASTE EXAMPLE
BASED ON 0.125 THICK STENCIL
SCALE:15X

4214838/F 08/2024

NOTES: (continued)

7. Laser cutting apertures with trapezoidal walls and rounded corners may offer better paste release. IPC-7525 may have alternate design recommendations.
8. Board assembly site may have different recommendations for stencil design.

IMPORTANT NOTICE AND DISCLAIMER

TI PROVIDES TECHNICAL AND RELIABILITY DATA (INCLUDING DATA SHEETS), DESIGN RESOURCES (INCLUDING REFERENCE DESIGNS), APPLICATION OR OTHER DESIGN ADVICE, WEB TOOLS, SAFETY INFORMATION, AND OTHER RESOURCES "AS IS" AND WITH ALL FAULTS, AND DISCLAIMS ALL WARRANTIES, EXPRESS AND IMPLIED, INCLUDING WITHOUT LIMITATION ANY IMPLIED WARRANTIES OF MERCHANTABILITY, FITNESS FOR A PARTICULAR PURPOSE OR NON-INFRINGEMENT OF THIRD PARTY INTELLECTUAL PROPERTY RIGHTS.

These resources are intended for skilled developers designing with TI products. You are solely responsible for (1) selecting the appropriate TI products for your application, (2) designing, validating and testing your application, and (3) ensuring your application meets applicable standards, and any other safety, security, regulatory or other requirements.

These resources are subject to change without notice. TI grants you permission to use these resources only for development of an application that uses the TI products described in the resource. Other reproduction and display of these resources is prohibited. No license is granted to any other TI intellectual property right or to any third party intellectual property right. TI disclaims responsibility for, and you will fully indemnify TI and its representatives against, any claims, damages, costs, losses, and liabilities arising out of your use of these resources.

TI's products are provided subject to [TI's Terms of Sale](#) or other applicable terms available either on [ti.com](https://www.ti.com) or provided in conjunction with such TI products. TI's provision of these resources does not expand or otherwise alter TI's applicable warranties or warranty disclaimers for TI products.

TI objects to and rejects any additional or different terms you may have proposed.

Mailing Address: Texas Instruments, Post Office Box 655303, Dallas, Texas 75265
Copyright © 2024, Texas Instruments Incorporated