



## 24-BIT, 192-kHz SAMPLING, ADVANCED SEGMENT, AUDIO STEREO DIGITAL-TO-ANALOG CONVERTER

### FEATURES

- 24-Bit Resolution
- Analog Performance:
  - Dynamic Range: 123 dB
  - THD+N: 0.0005%
- Differential Current Output: 4 mA p-p
- 8× Oversampling Digital Filter:
  - Stop-Band Attenuation: –98 dB
  - Pass-Band Ripple: ±0.0002 dB
- Sampling Frequency: 10 kHz to 200 kHz
- System Clock: 128, 192, 256, 384, 512, or 768 f<sub>s</sub> With Autodetect
- Accepts 16-, 20-, and 24-Bit Audio Data
- PCM Data Formats: Standard, I<sup>2</sup>S, and Left-Justified
- DSD Format Interface Available
- Interface Available for Optional External Digital Filter or DSP
- TDMCA or Serial Port (SPI/I<sup>2</sup>C)
- User-Programmable Mode Controls:
  - Digital Attenuation: 0 dB to –120 dB, 0.5 dB/Step
  - Digital De-Emphasis
  - Digital Filter Rolloff: Sharp or Slow
  - Soft Mute
  - Zero Flag for Each Output
- Compatible With PCM1792 (Pins and Mode Controls)
- Dual Supply Operation:
  - 5-V Analog, 3.3-V Digital

- 5-V Tolerant Digital Inputs
- Small 28-Lead SSOP Package

### APPLICATIONS

- A/V Receivers
- SACD Players
- DVD Players
- HDTV Receivers
- Car Audio Systems
- Digital Multitrack Recorders
- Other Applications Requiring 24-Bit Audio

### DESCRIPTION

The PCM1796 is a monolithic CMOS integrated circuit that includes stereo digital-to-analog converters and support circuitry in a small 28-lead SSOP package. The data converters use TI's advanced segment DAC architecture to achieve excellent dynamic performance and improved tolerance to clock jitter. The PCM1796 provides balanced current outputs, allowing the user to optimize analog performance externally. The PCM1796 accepts PCM and DSD audio data formats, providing easy interfacing to audio DSP and decoder chips. The PCM1796 also interfaces with external digital filter devices (DF1704, DF1706, PMD200). Sampling rates up to 200 kHz are supported. A full set of user-programmable functions is accessible through an SPI or I<sup>2</sup>C serial control port, which supports register write and readback functions. The PCM1796 also supports the time division multiplexed command and audio (TDMCA) data format.



This integrated circuit can be damaged by ESD. Texas Instruments recommends that all integrated circuits be handled with appropriate precautions. Failure to observe proper handling and installation procedures can cause damage.

ESD damage can range from subtle performance degradation to complete device failure. Precision integrated circuits may be more susceptible to damage because very small parametric changes could cause the device not to meet its published specifications.



Please be aware that an important notice concerning availability, standard warranty, and use in critical applications of Texas Instruments semiconductor products and disclaimers thereto appears at the end of this data sheet.

**ORDERING INFORMATION**

PRODUCT	PACKAGE	PACKAGE CODE	OPERATION TEMPERATURE RANGE	PACKAGE MARKING	ORDERING NUMBER	TRANSPORT MEDIA
PCM1796DB	28-lead SSOP	28DB	–25°C to 85°C	PCM1796	PCM1796DB	Tube
					PCM1796DBR	Tape and reel

**ABSOLUTE MAXIMUM RATINGS**over operating free-air temperature range unless otherwise noted<sup>(1)</sup>

		PCM1796
Supply voltage	V <sub>CC1</sub> , V <sub>CC2L</sub> , V <sub>CC2R</sub>	–0.3 V to 6.5 V
	V <sub>DD</sub>	–0.3 V to 4 V
Supply voltage differences: V <sub>CC1</sub> , V <sub>CC2L</sub> , V <sub>CC2R</sub>		±0.1 V
Ground voltage differences: AGND1, AGND2, AGND3L, AGND3R, DGND		±0.1 V
Digital input voltage	LRCK, DATA, BCK, SCK, MSEL, <u>RST</u> , MS <sup>(2)</sup> , MDI, MC, MDO <sup>(2)</sup> , ZEROL <sup>(2)</sup> , ZEROR <sup>(2)</sup>	–0.3 V to 6.5 V
	ZEROL <sup>(3)</sup> , ZEROR <sup>(3)</sup> , MDO <sup>(3)</sup> , MS <sup>(3)</sup>	–0.3 V to (V <sub>DD</sub> + 0.3 V) < 4 V
Analog input voltage		–0.3 V to (V <sub>CC</sub> + 0.3 V) < 6.5 V
Input current (any pins except supplies)		±10 mA
Ambient temperature under bias		–40°C to 125°C
Storage temperature		–55°C to 150°C
Junction temperature		150°C
Lead temperature (soldering)		260°C, 5 s
Package temperature (IR reflow, peak)		260°C

(1) Stresses beyond those listed under “absolute maximum ratings” may cause permanent damage to the device. These are stress ratings only, and functional operation of the device at these or any other conditions beyond those indicated under “recommended operating conditions” is not implied. Exposure to absolute-maximum-rated conditions for extended periods may affect device reliability.

(2) Input mode or I<sup>2</sup>C mode

(3) Output mode except for I<sup>2</sup>C mode

**ELECTRICAL CHARACTERISTICS**

all specifications at T<sub>A</sub> = 25°C, V<sub>CC1</sub> = V<sub>CC2L</sub> = V<sub>CC2R</sub> = 5 V, V<sub>DD</sub> = 3.3 V, f<sub>S</sub> = 44.1 kHz, system clock = 256 f<sub>S</sub>, and 24-bit data unless otherwise noted

PARAMETER	TEST CONDITIONS	PCM1796DB			UNIT
		MIN	TYP	MAX	
<b>RESOLUTION</b>			24		Bits
<b>DATA FORMAT (PCM Mode)</b>					
Audio data interface format		Standard, I <sup>2</sup> S, left-justified			
Audio data bit length		16-, 20-, 24-bit selectable			
Audio data format		MSB first, twos complement			
f <sub>S</sub> Sampling frequency		10		200	kHz
System clock frequency		128, 192, 256, 384, 512, 768 f <sub>S</sub>			
<b>DATA FORMAT (DSD Mode)</b>					
Audio data interface format		DSD (direct stream digital)			
Audio data bit length		1 Bit			
f <sub>S</sub> Sampling frequency			2.8224		MHz
System clock frequency		2.8224		11.2896	MHz

**ELECTRICAL CHARACTERISTICS (Continued)**

 all specifications at  $T_A = 25^\circ\text{C}$ ,  $V_{CC1} = V_{CC2L} = V_{CC2R} = 5\text{ V}$ ,  $V_{DD} = 3.3\text{ V}$ ,  $f_S = 44.1\text{ kHz}$ , system clock =  $256 f_S$ , and 24-bit data unless otherwise noted

PARAMETER	TEST CONDITIONS	PCM1796DB			UNIT
		MIN	TYP	MAX	
<b>DIGITAL INPUT/OUTPUT</b>					
Logic family		TTL compatible			
$V_{IH}$	Input logic level	2			VDC
$V_{IL}$		0.8			
$I_{IH}$	Input logic current	$V_{IN} = V_{DD}$	10		$\mu\text{A}$
$I_{IL}$		$V_{IN} = 0\text{ V}$	-10		
$V_{OH}$	Output logic level	$I_{OH} = -2\text{ mA}$	2.4		VDC
$V_{OL}$		$I_{OL} = 2\text{ mA}$	0.4		
<b>DYNAMIC PERFORMANCE (PCM MODE) (1)(2)</b>					
THD+N at $V_{OUT} = 0\text{ dB}$	$f_S = 44.1\text{ kHz}$	0.0005%	0.001%		
	$f_S = 96\text{ kHz}$	0.001%			
	$f_S = 192\text{ kHz}$	0.0015%			
Dynamic range	EIAJ, A-weighted, $f_S = 44.1\text{ kHz}$	120	123		dB
	EIAJ, A-weighted, $f_S = 96\text{ kHz}$	123			
	EIAJ, A-weighted, $f_S = 192\text{ kHz}$	123			
Signal-to-noise ratio	EIAJ, A-weighted, $f_S = 44.1\text{ kHz}$	120	123		dB
	EIAJ, A-weighted, $f_S = 96\text{ kHz}$	123			
	EIAJ, A-weighted, $f_S = 192\text{ kHz}$	123			
Channel separation	$f_S = 44.1\text{ kHz}$	116	119		dB
	$f_S = 96\text{ kHz}$	118			
	$f_S = 192\text{ kHz}$	117			
Level Linearity Error	$V_{OUT} = -120\text{ dB}$	$\pm 1$			dB
<b>DYNAMIC PERFORMANCE (MONO MODE) (1)(2)(3)</b>					
THD+N at $V_{OUT} = 0\text{ dB}$	$f_S = 44.1\text{ kHz}$	0.0005%			
	$f_S = 96\text{ kHz}$	0.001%			
	$f_S = 192\text{ kHz}$	0.0015%			
Dynamic range	EIAJ, A-weighted, $f_S = 44.1\text{ kHz}$	126			dB
	EIAJ, A-weighted, $f_S = 96\text{ kHz}$	126			
	EIAJ, A-weighted, $f_S = 192\text{ kHz}$	126			
Signal-to-noise ratio	EIAJ, A-weighted, $f_S = 44.1\text{ kHz}$	126			dB
	EIAJ, A-weighted, $f_S = 96\text{ kHz}$	126			
	EIAJ, A-weighted, $f_S = 192\text{ kHz}$	126			

(1) Filter condition:

THD+N: 20-Hz HPF, 20-kHz AES17 LPF

Dynamic range: 20-Hz HPF, 20-kHz AES17 LPF, A-weighted

Signal-to-noise ratio: 20-Hz HPF, 20-kHz AES17 LPF, A-weighted

Channel separation: 20-Hz HPF, 20-kHz AES17 LPF

Analog performance specifications are measured using the System Two™ Cascade audio measurement system by Audio Precision™ in the averaging mode.

(2) Dynamic performance and dc accuracy are specified at the output of the postamplifier as shown in Figure 36.

(3) Dynamic performance and dc accuracy are specified at the output of the measurement circuit as shown in Figure 38.

**ELECTRICAL CHARACTERISTICS (Continued)**

all specifications at  $T_A = 25^\circ\text{C}$ ,  $V_{CC1} = V_{CC2L} = V_{CC2R} = 5\text{ V}$ ,  $V_{DD} = 3.3\text{ V}$ ,  $f_S = 44.1\text{ kHz}$ , system clock =  $256 f_S$ , and 24-bit data unless otherwise noted

PARAMETER	TEST CONDITIONS	PCM1796DB			UNIT
		MIN	TYP	MAX	
<b>DSD MODE DYNAMIC PERFORMANCE (1) (2) (44.1 kHz, 64 f<sub>S</sub>)</b>					
THD+N at FS	2 V rms	0.0007%			
Dynamic range	-60 dB, EIAJ, A-weighted	122			dB
Signal-to-noise ratio	EIAJ, A-weighted	122			dB
<b>ANALOG OUTPUT</b>					
Gain error		-7	±2	7	% of FSR
Gain mismatch, channel-to-channel		-3	±0.5	3	% of FSR
Bipolar zero error	At BPZ	-2	±0.5	2	% of FSR
Output current	Full scale (0 dB)	4			mA p-p
Center current	At BPZ	-3.5			mA
<b>DIGITAL FILTER PERFORMANCE</b>					
De-emphasis error		±0.1			dB
<b>FILTER CHARACTERISTICS-1: SHARP ROLLOFF</b>					
Pass band	±0.0002 dB	0.454 f <sub>S</sub>			
	-3 dB	0.49 f <sub>S</sub>			
Stop band		0.546 f <sub>S</sub>			
Pass-band ripple		±0.0002			dB
Stop-band attenuation	Stop band = 0.546 f <sub>S</sub>	-98			dB
Delay time		38/f <sub>S</sub>			s
<b>FILTER CHARACTERISTICS-2: SLOW ROLLOFF</b>					
Pass band	±0.001 dB	0.21 f <sub>S</sub>			
	-3 dB	0.448 f <sub>S</sub>			
Stop band		0.79 f <sub>S</sub>			
Pass-band ripple		±0.001			dB
Stop-band attenuation	Stop band = 0.732 f <sub>S</sub>	-80			dB
Delay time		38/f <sub>S</sub>			s

(1) Filter condition:

THD+N: 20-Hz HPF, 20-kHz AES17 LPF

Dynamic range: 20-Hz HPF, 20-kHz AES17 LPF, A-weighted

Signal-to-noise ratio: 20-Hz HPF, 20-kHz AES17 LPF, A-weighted

Channel separation: 20-Hz HPF, 20-kHz AES17 LPF

Analog performance specifications are measured using the System Two Cascade audio measurement system by Audio Precision in the averaging mode.

(2) Dynamic performance and dc accuracy are specified at the output of the postamplifier as shown in Figure 37.



## Terminal Functions

TERMINAL NAME	PIN	I/O	DESCRIPTIONS
AGND1	19	–	Analog ground (internal bias)
AGND2	24	–	Analog ground (internal bias)
AGND3L	27	–	Analog ground (L-channel DACFF)
AGND3R	16	–	Analog ground (R-channel DACFF)
BCK	6	I	Bit clock input <sup>(1)</sup>
DATA	5	I	Serial audio data input <sup>(1)</sup>
DGND	8	–	Digital ground
I <sub>OUTL+</sub>	25	O	L-channel analog current output+
I <sub>OUTL-</sub>	26	O	L-channel analog current output–
I <sub>OUTR+</sub>	17	O	R-channel analog current output+
I <sub>OUTR-</sub>	18	O	R-channel analog current output–
I <sub>REF</sub>	20	–	Output current reference bias pin
LRCK	4	I	Left and right clock (f <sub>S</sub> ) input <sup>(1)</sup>
MC	12	I	Mode control clock input <sup>(1)</sup>
MDI	11	I	Mode control data input <sup>(1)</sup>
MDO	13	I/O	Mode control readback data output <sup>(3)</sup>
$\overline{\text{MS}}$	10	I/O	Mode control chip-select input <sup>(2)</sup>
MSEL	3	I	I <sup>2</sup> C/SPI select <sup>(1)</sup>
$\overline{\text{RST}}$	14	I	Reset <sup>(1)</sup>
SCK	7	I	System clock input <sup>(1)</sup>
V <sub>CC1</sub>	23	–	Analog power supply, 5 V
V <sub>CC2L</sub>	28	–	Analog power supply (L-channel DACFF), 5 V
V <sub>CC2R</sub>	15	–	Analog power supply (R-channel DACFF), 5 V
V <sub>COML</sub>	22	–	L-channel internal bias decoupling pin
V <sub>COMR</sub>	21	–	R-channel internal bias decoupling pin
V <sub>DD</sub>	9	–	Digital power supply, 3.3 V
ZEROL	1	I/O	Zero flag for L-channel <sup>(2)</sup>
ZEROR	2	I/O	Zero flag for R-channel <sup>(2)</sup>

<sup>(1)</sup> Schmitt-trigger input, 5-V tolerant

<sup>(2)</sup> Schmitt-trigger input and output. 5-V tolerant input and CMOS output

<sup>(3)</sup> Schmitt-trigger input and output. 5-V tolerant input. In I<sup>2</sup>C mode, this pin becomes an open-drain 3-state output; otherwise, this pin is a CMOS output.

**FUNCTIONAL BLOCK DIAGRAM**

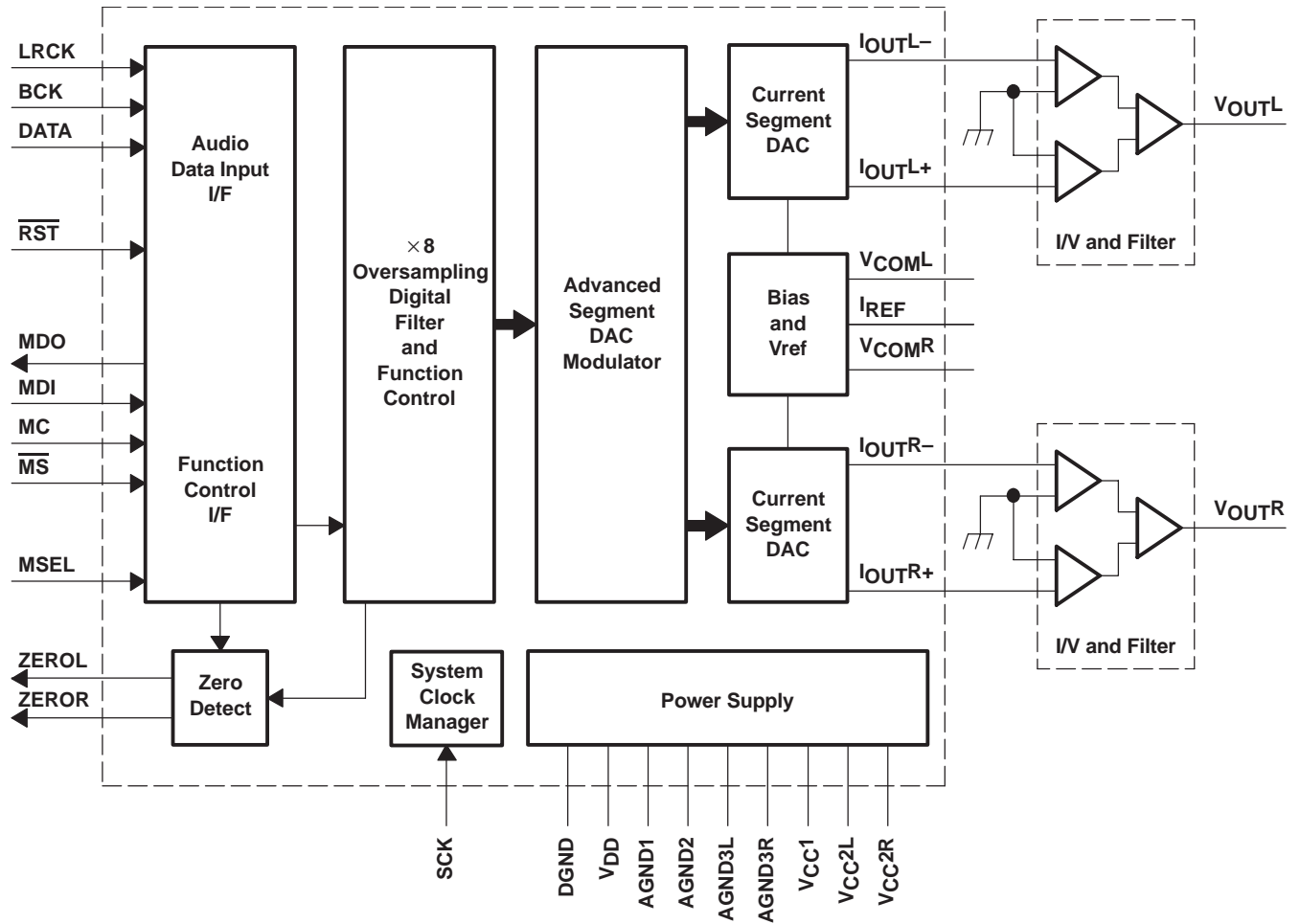

TYPICAL PERFORMANCE CURVES

DIGITAL FILTER

Digital Filter Response

AMPLITUDE  
vs  
FREQUENCY

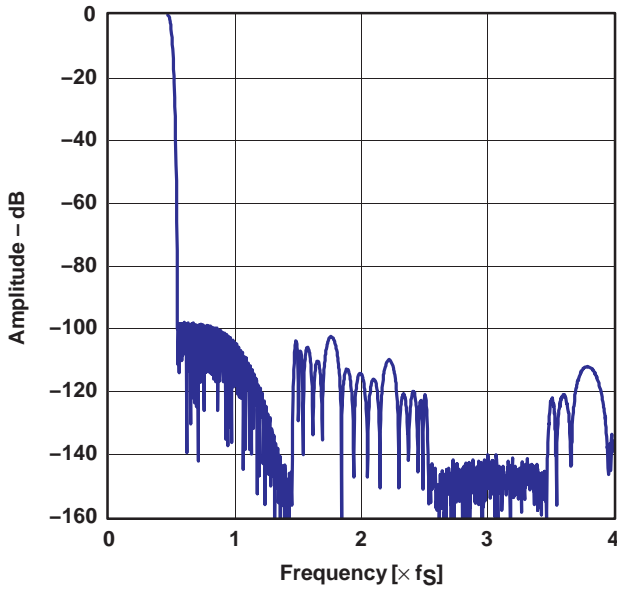

Figure 1. Frequency Response, Sharp Rolloff

AMPLITUDE  
vs  
FREQUENCY

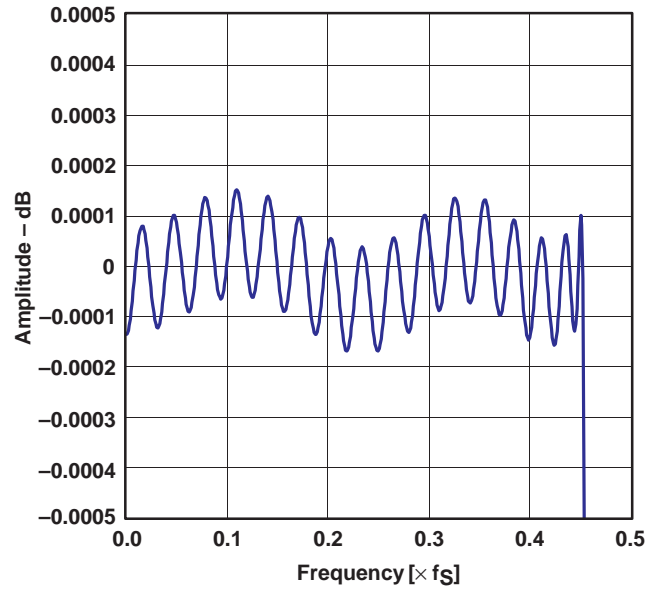

Figure 2. Pass-Band Ripple, Sharp Rolloff

AMPLITUDE  
vs  
FREQUENCY

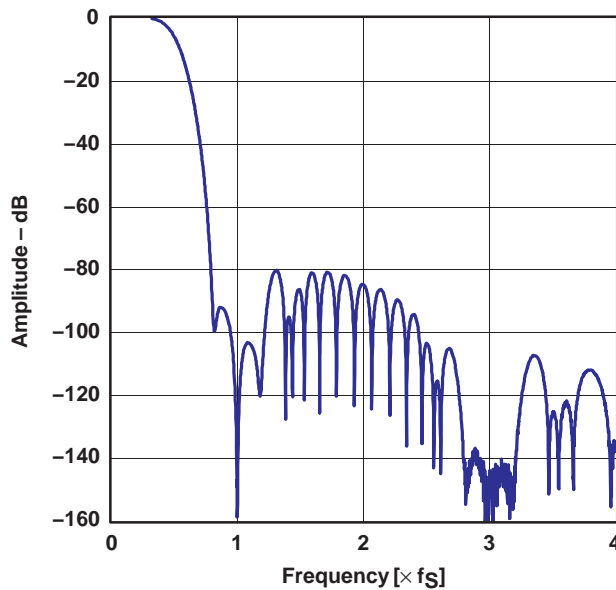

Figure 3. Frequency Response, Slow Rolloff

AMPLITUDE  
vs  
FREQUENCY

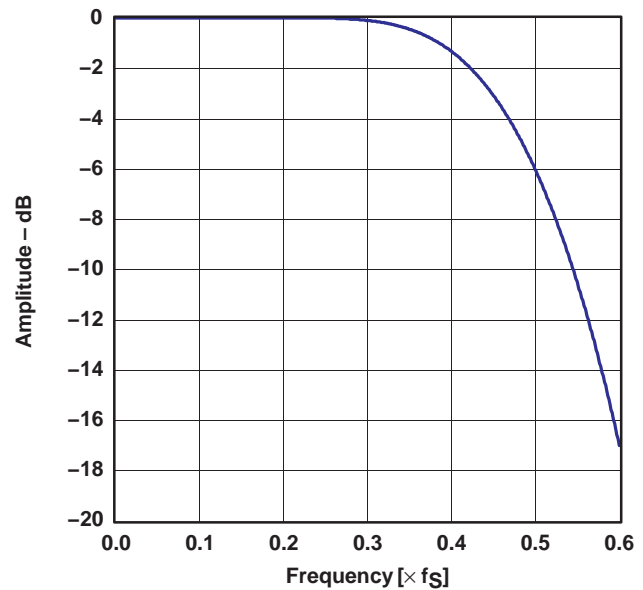

Figure 4. Transition Characteristics, Slow Rolloff



De-Emphasis Filter

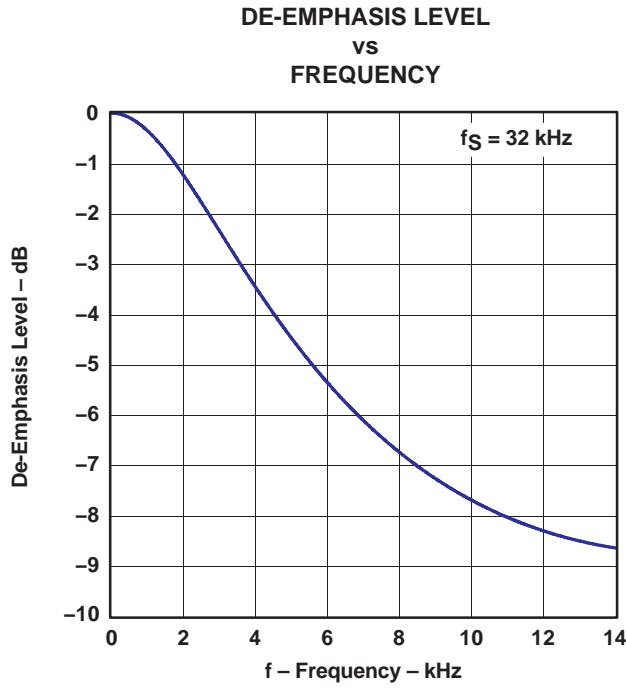

Figure 5

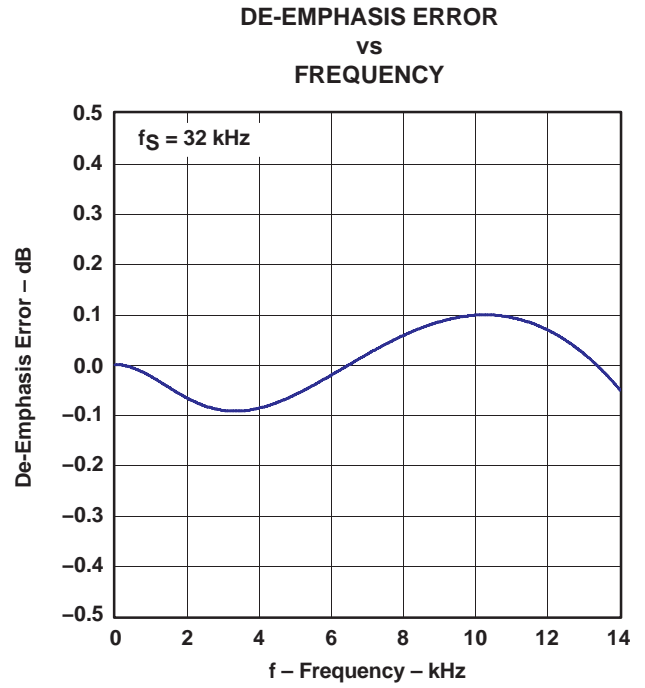

Figure 6

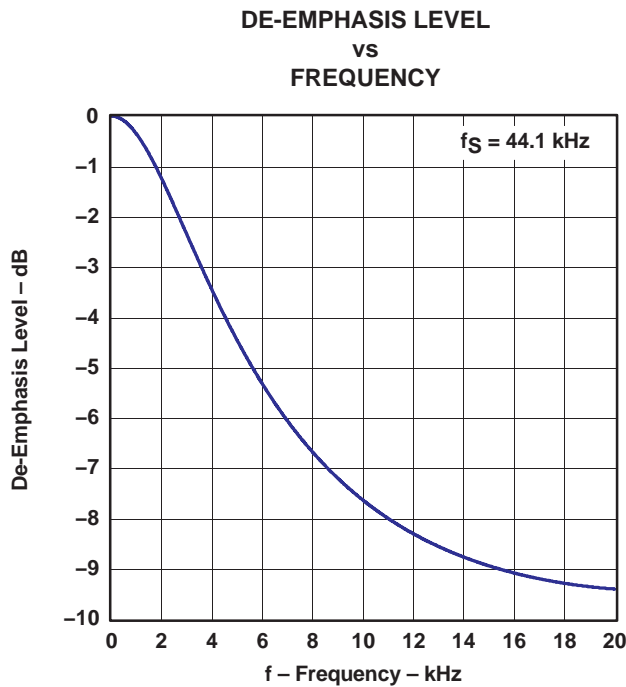

Figure 7

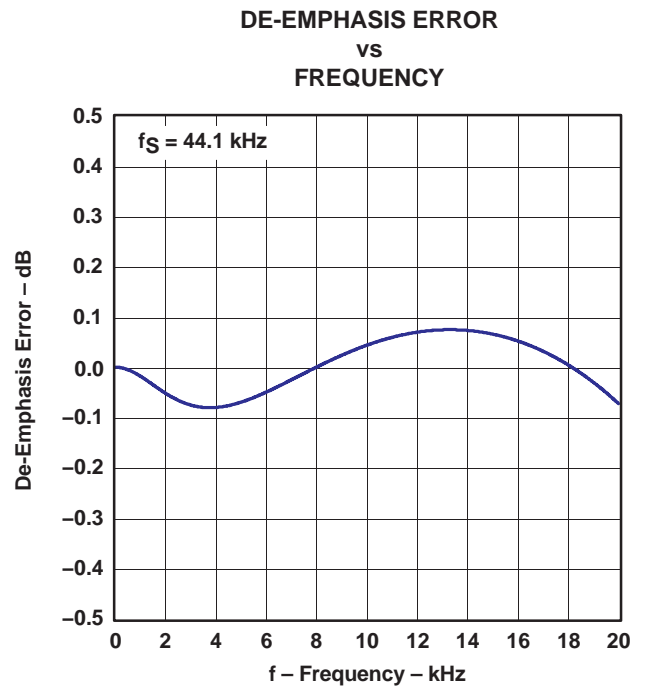

Figure 8

De-Emphasis Filter (Continued)

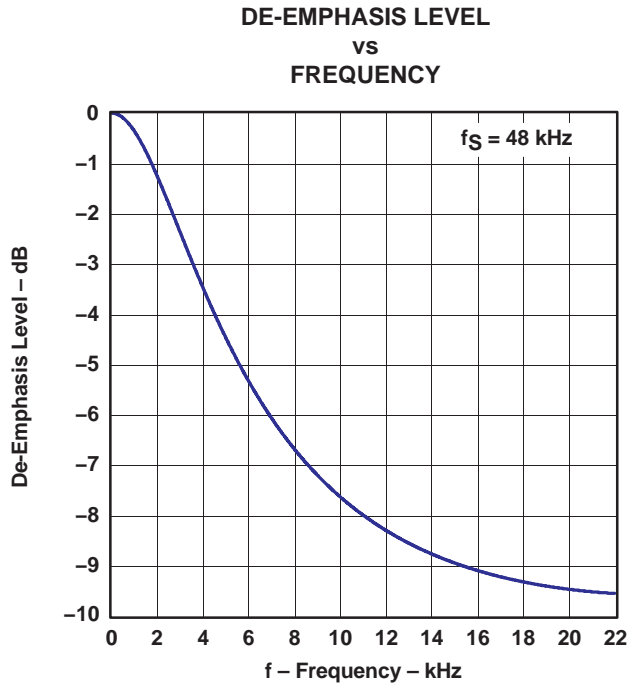

Figure 9

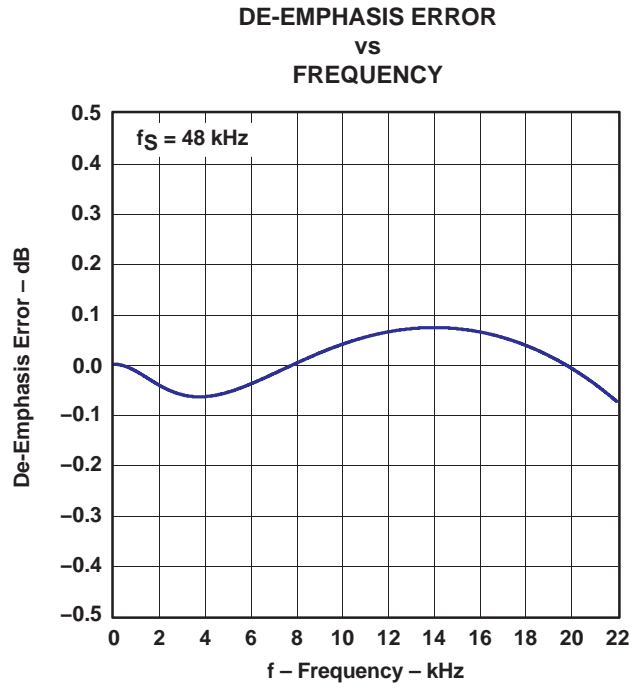
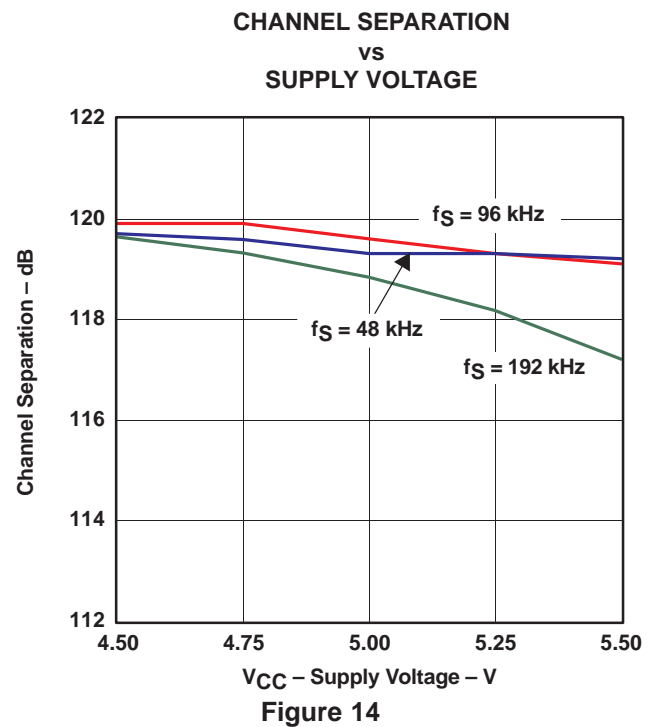
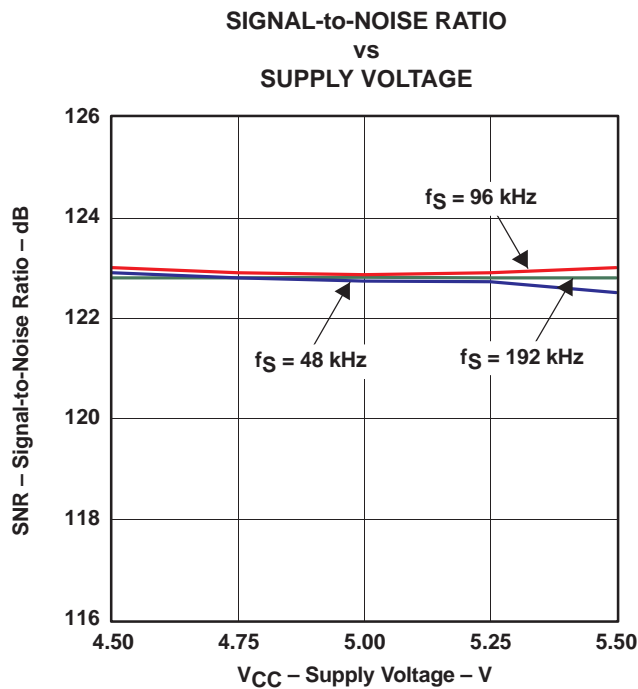
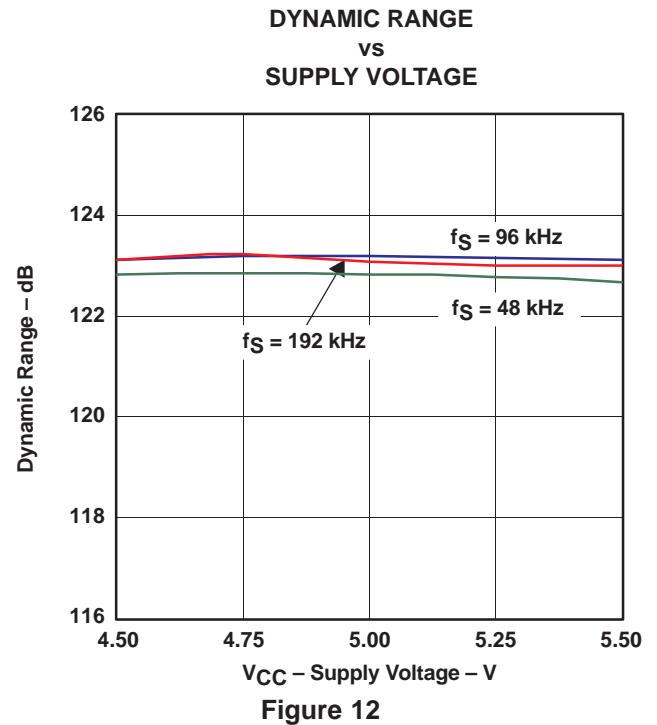
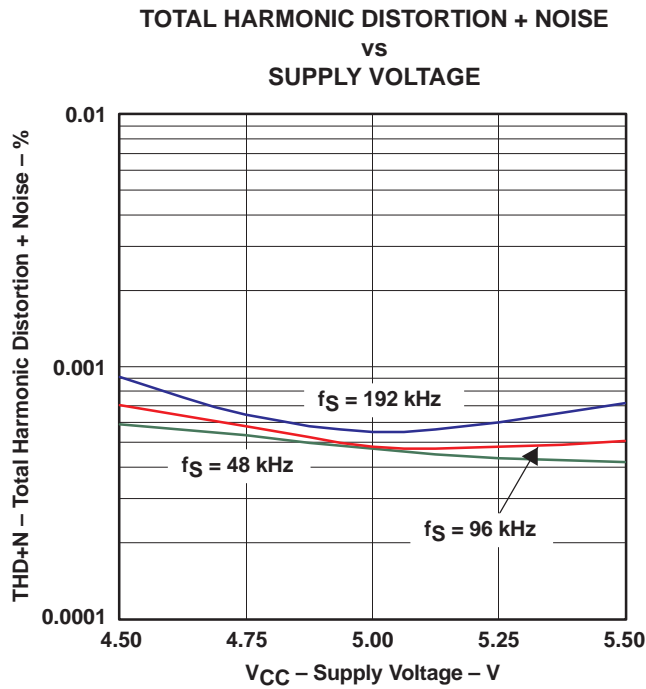

Figure 10

## ANALOG DYNAMIC PERFORMANCE

### Supply Voltage Characteristics



NOTE: PCM mode,  $T_A = 25^\circ\text{C}$ ,  $V_{DD} = 3.3\text{ V}$ , measurement circuit is Figure 36.

Temperature Characteristics

TOTAL HARMONIC DISTORTION + NOISE  
vs  
FREE-AIR TEMPERATURE

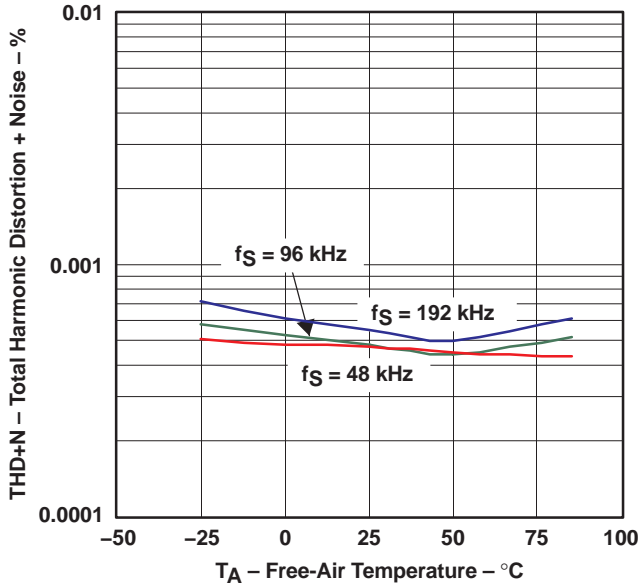

Figure 15

DYNAMIC RANGE  
vs  
FREE-AIR TEMPERATURE

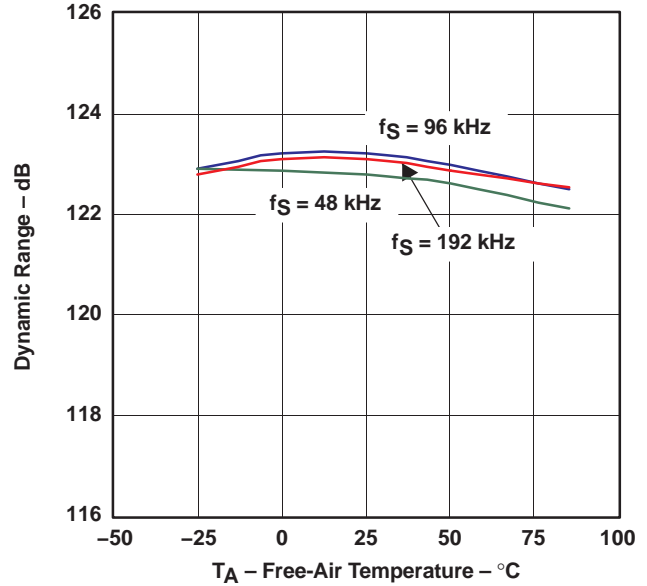

Figure 16

SIGNAL-to-NOISE RATIO  
vs  
FREE-AIR TEMPERATURE

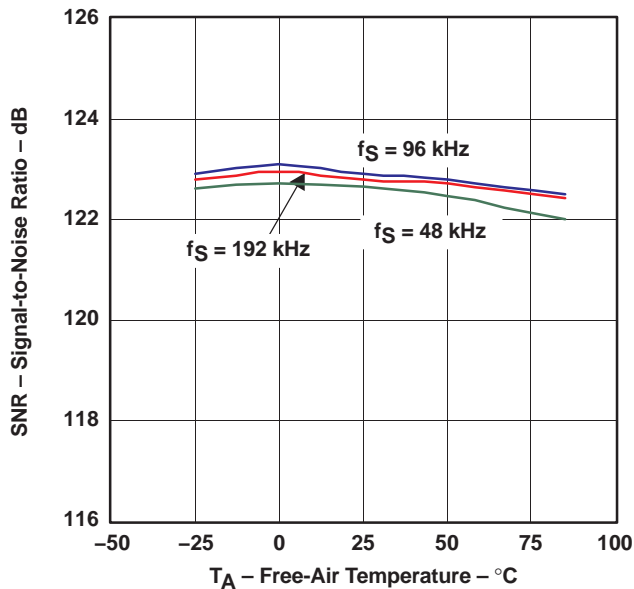

Figure 17

CHANNEL SEPARATION  
vs  
FREE-AIR TEMPERATURE

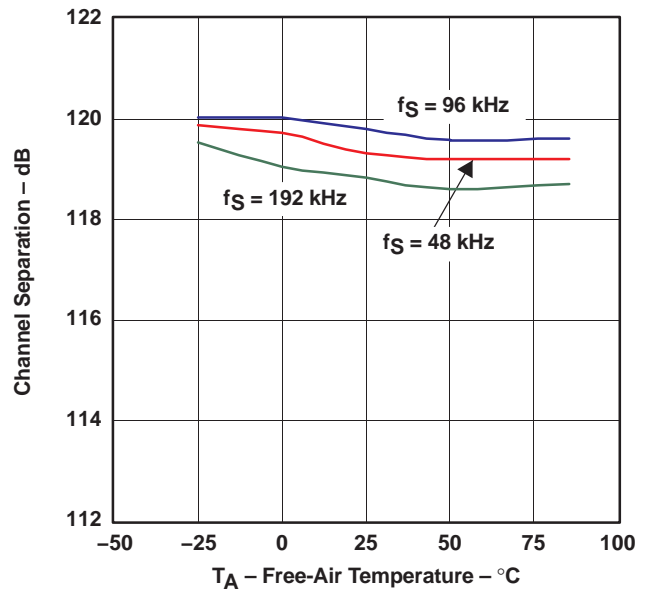
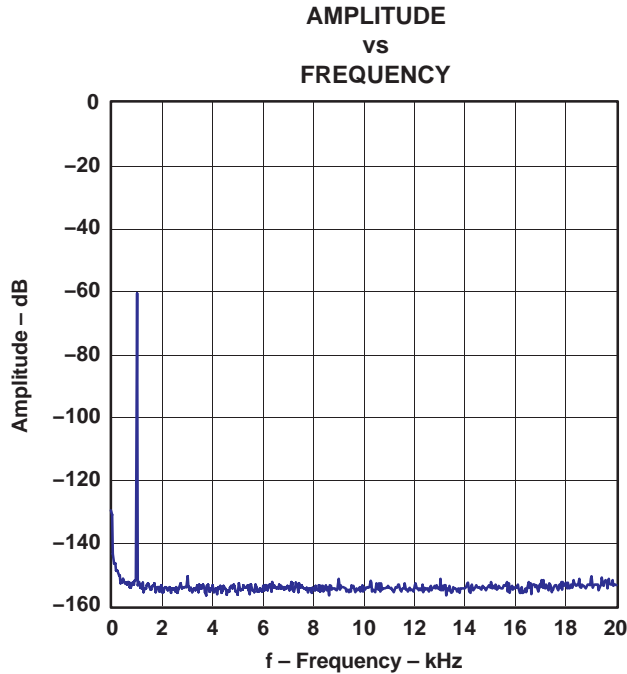

Figure 18

NOTE: PCM mode, V<sub>DD</sub> = 3.3 V, V<sub>CC</sub> = 5 V, measurement circuit is Figure 36.



NOTE: PCM mode,  $f_S = 48$  kHz, 32768 point 8 average,  $T_A = 25^\circ\text{C}$ ,  $V_{DD} = 3.3$  V  $V_{CC} = 5$  V, measurement circuit is Figure 36.

Figure 19. -60-dB Output Spectrum, BW = 20 kHz

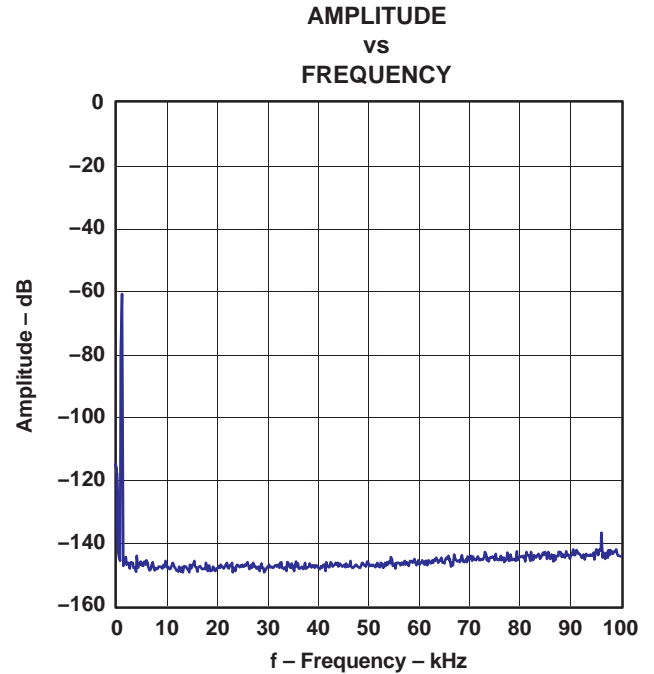

NOTE: PCM mode,  $f_S = 96$  kHz, 32768 point 8 average,  $T_A = 25^\circ\text{C}$ ,  $V_{DD} = 3.3$  V  $V_{CC} = 5$  V, measurement circuit is Figure 36.

Figure 20. -60-dB Output Spectrum, BW = 100 kHz

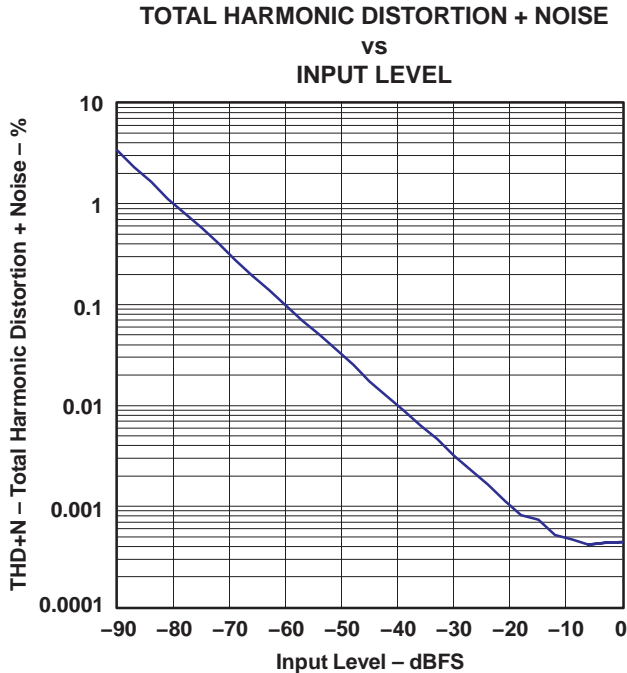

NOTE: PCM mode,  $f_S = 48$  kHz,  $T_A = 25^\circ\text{C}$ ,  $V_{DD} = 3.3$  V,  $V_{CC} = 5$  V, measurement circuit is Figure 36.

Figure 21. THD+N vs Input Level, PCM Mode

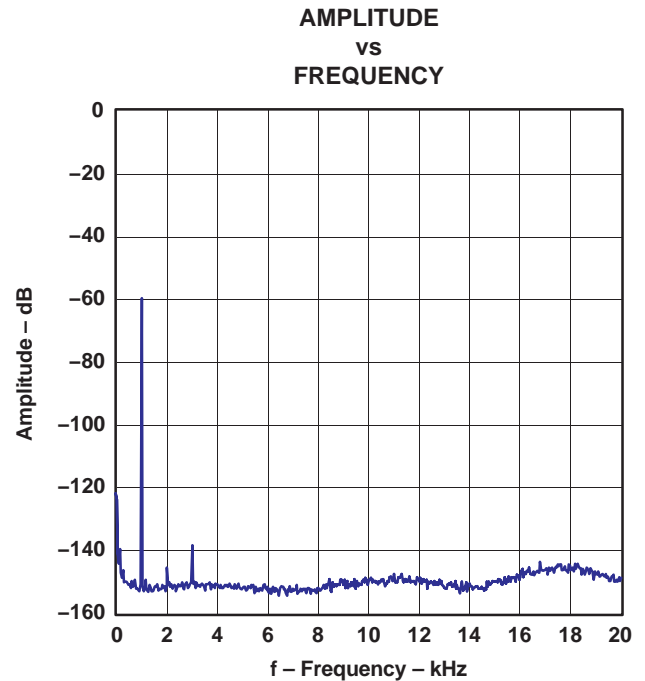

NOTE: DSD mode (FIR-2), 32768 point 8 average,  $T_A = 25^\circ\text{C}$ ,  $V_{DD} = 3.3$  V,  $V_{CC} = 5$  V, measurement circuit is Figure 37.

Figure 22. -60-dB Output Spectrum, DSD Mode

## SYSTEM CLOCK AND RESET FUNCTIONS

### System Clock Input

The PCM1796 requires a system clock for operating the digital interpolation filters and advanced segment DAC modulators. The system clock is applied at the SCK input (pin 7). The PCM1796 has a system clock detection circuit that automatically senses the frequency at which the system clock is operating. Table 1 shows examples of system clock frequencies for common audio sampling rates. If the oversampling rate of the delta-sigma modulator is selected as  $128 f_S$ , the system clock frequency is required to be over  $256 f_S$ .

Figure 23 shows the timing requirements for the system clock input. For optimal performance, it is important to use a clock source with low phase jitter and noise. One of the Texas Instruments PLL1700 family of multiclock generators is an excellent choice for providing the PCM1796 system clock.

**Table 1. System Clock Rates for Common Audio Sampling Frequencies**

SAMPLING FREQUENCY	SYSTEM CLOCK FREQUENCY ( $f_{SCK}$ ) (MHz)					
	128 $f_S$	192 $f_S$	256 $f_S$	384 $f_S$	512 $f_S$	768 $f_S$
32 kHz	4.096 <sup>(1)</sup>	6.144 <sup>(1)</sup>	8.192	12.288	16.384	24.576
44.1 kHz	5.6488 <sup>(1)</sup>	8.4672	11.2896	16.9344	22.5792	33.8688
48 kHz	6.144 <sup>(1)</sup>	9.216	12.288	18.432	24.576	36.864
96 kHz	12.288	18.432	24.576	36.864	49.152 <sup>(1)</sup>	73.728 <sup>(1)</sup>
192 kHz	24.576	36.864	49.152 <sup>(1)</sup>	73.728 <sup>(1)</sup>	— <sup>(2)</sup>	— <sup>(2)</sup>

<sup>(1)</sup> This system clock rate is not supported in I<sup>2</sup>C fast mode.

<sup>(2)</sup> This system clock rate is not supported for the given sampling frequency.

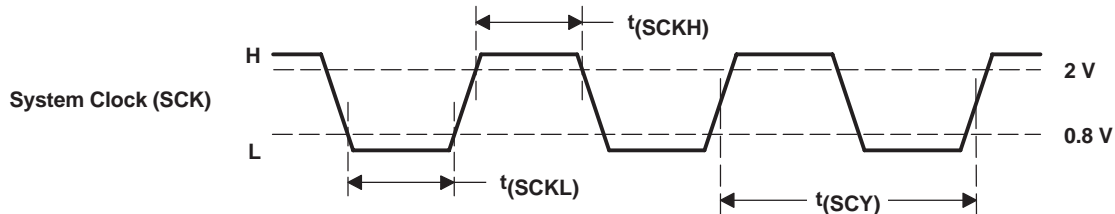

PARAMETERS		MIN	MAX	UNITS
$t_{SCY}$	System clock pulse cycle time	13		ns
$t_{SCKH}$	System clock pulse duration, HIGH	$0.4t_{SCY}$		ns
$t_{SCKL}$	System clock pulse duration, LOW	$0.4t_{SCY}$		ns

**Figure 23. System Clock Input Timing**

## Power-On and External Reset Functions

The PCM1796 includes a power-on reset function. Figure 24 shows the operation of this function. With  $V_{DD} > 2\text{ V}$ , the power-on reset function is enabled. The initialization sequence requires 1024 system clocks from the time  $V_{DD} > 2\text{ V}$ . After the initialization period, the PCM1796 is set to its default reset state, as described in the *MODE CONTROL REGISTERS* section of this data sheet.

The PCM1796 also includes an external reset capability using the  $\overline{\text{RST}}$  input (pin 14). This allows an external controller or master reset circuit to force the PCM1796 to initialize to its default reset state.

Figure 25 shows the external reset operation and timing. The  $\overline{\text{RST}}$  pin is set to logic 0 for a minimum of 20 ns. The  $\overline{\text{RST}}$  pin is then set to a logic 1 state, thus starting the initialization sequence, which requires 1024 system clock periods. The external reset is especially useful in applications where there is a delay between the PCM1796 power up and system clock activation.

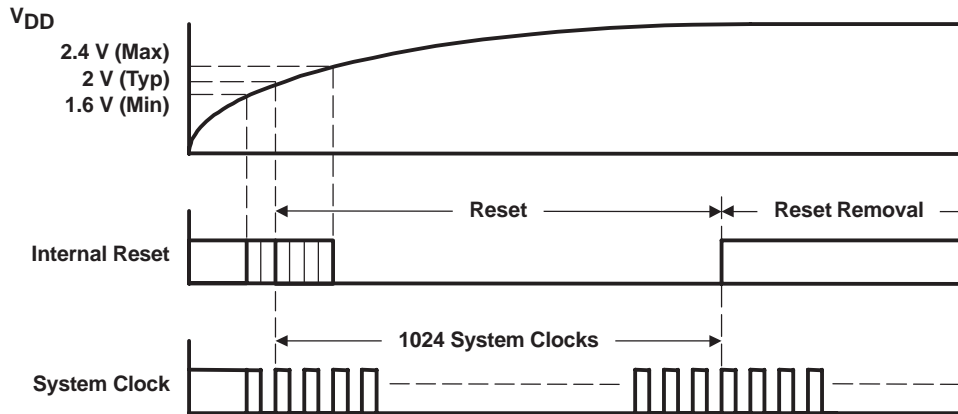

**Figure 24. Power-On Reset Timing**

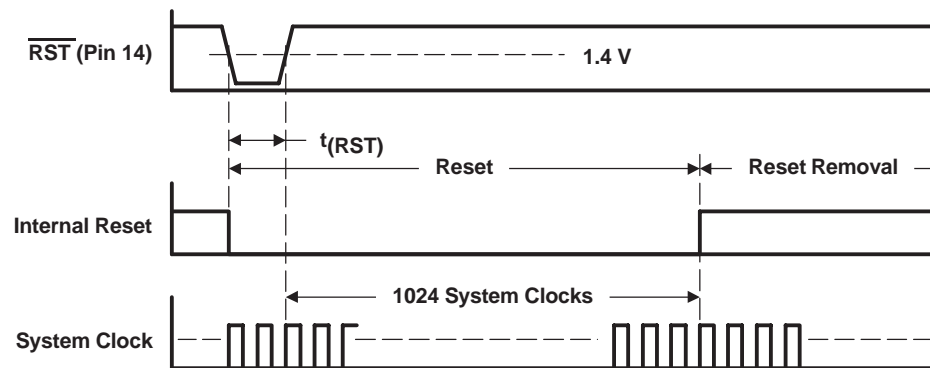

PARAMETERS		MIN	MAX	UNITS
$t_{\text{(RST)}}$	Reset pulse duration, LOW	20		ns

**Figure 25. External Reset Timing**

## AUDIO DATA INTERFACE

### Audio Serial Interface

The audio interface port is a 3-wire serial port. It includes LRCK (pin 4), BCK (pin 6), and DATA (pin 5). BCK is the serial audio bit clock, and it is used to clock the serial data present on DATA into the serial shift register of the audio interface. Serial data is clocked into the PCM1796 on the rising edge of BCK. LRCK is the serial audio left/right word clock.

The PCM1796 requires the synchronization of LRCK and system clock, but does not need a specific phase relation between LRCK and system clock.

If the relationship between LRCK and system clock changes more than  $\pm 6$  BCK, internal operation is initialized within  $1/f_S$  and analog outputs are forced to the bipolar zero level until resynchronization between LRCK and system clock is completed.

### PCM Audio Data Formats and Timing

The PCM1796 supports industry-standard audio data formats, including standard right-justified, I<sup>2</sup>S, and left-justified. The data formats are shown in Figure 27. Data formats are selected using the format bits, FMT[2:0], in control register 18. The default data format is 24-bit I<sup>2</sup>S. All formats require binary 2s complement, MSB-first audio data. Figure 26 shows a detailed timing diagram for the serial audio interface.

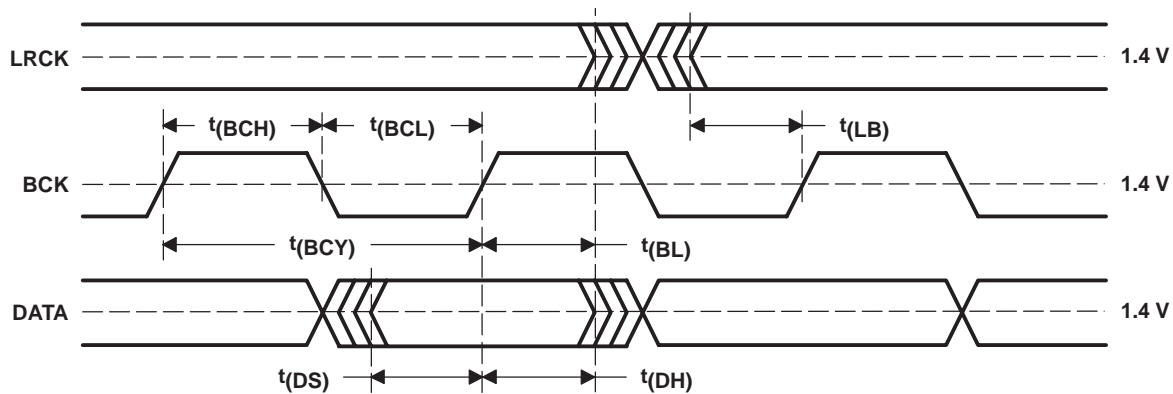

PARAMETERS		MIN	MAX	UNITS
$t(BCY)$	BCK pulse cycle time	70		ns
$t(BCL)$	BCK pulse duration, LOW	30		ns
$t(BCH)$	BCK pulse duration, HIGH	30		ns
$t(BL)$	BCK rising edge to LRCK edge	10		ns
$t(LB)$	LRCK edge to BCK rising edge	10		ns
$t(DS)$	DATA setup time	10		ns
$t(DH)$	DATA hold time	10		ns
—	LRCK clock data	50% $\pm$ 2 bit clocks		

Figure 26. Timing of Audio Interface



**(1) Standard Data Format (Right-Justified); L-Channel = HIGH, R-Channel = LOW**

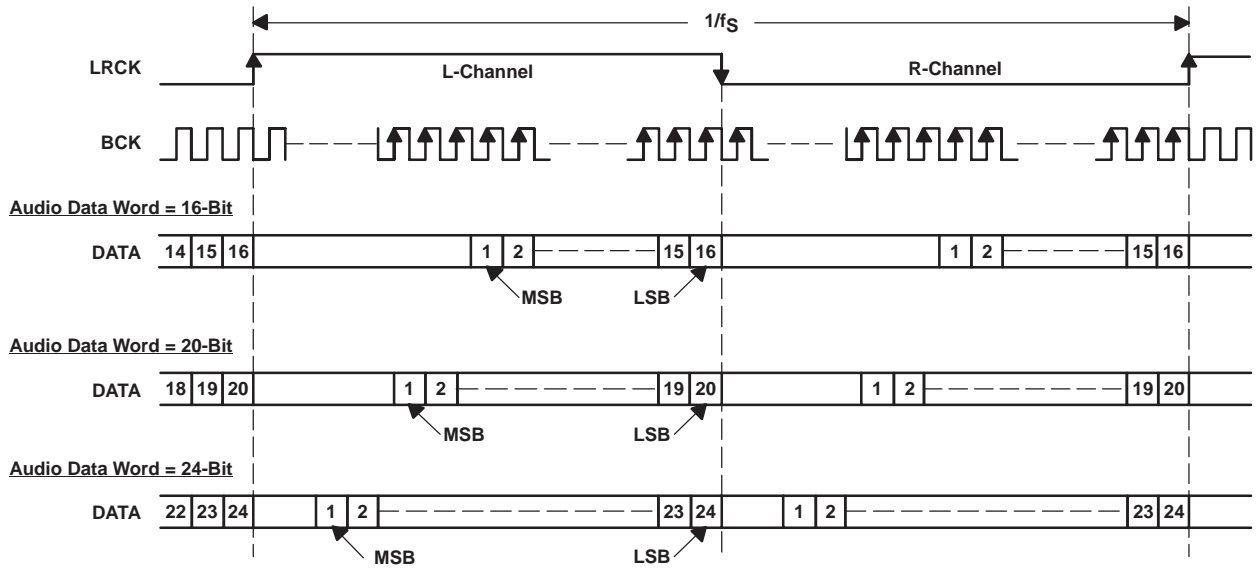

**(2) Left-Justified Data Format; L-Channel = HIGH, R-Channel = LOW**

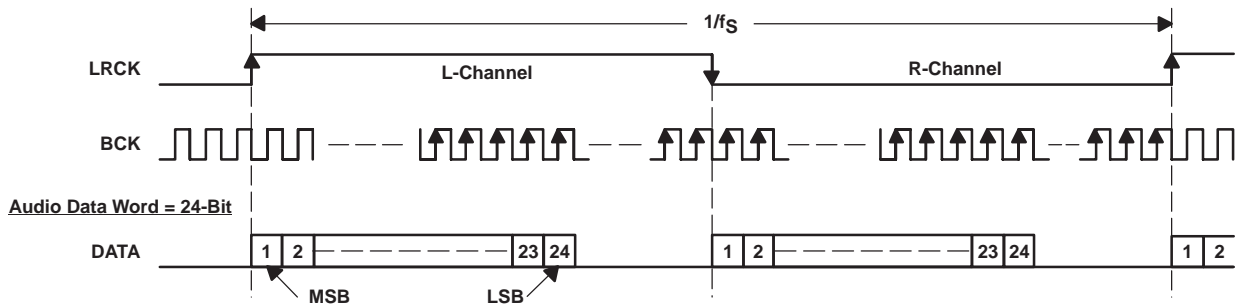

**(3) I<sup>2</sup>S Data Format; L-Channel = LOW, R-Channel = HIGH**

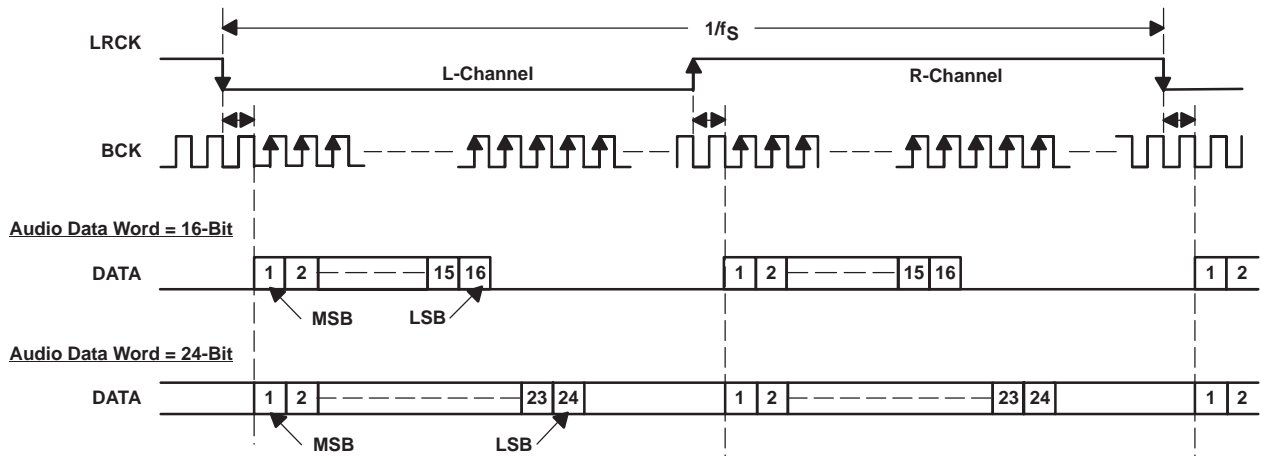

Figure 27. Audio Data Input Formats

## External Digital Filter Interface and Timing

The PCM1796 supports an external digital filter interface comprising a 3- or 4-wire synchronous serial port, which allows the use of an external digital filter. External filters include the Texas Instruments' DF1704 and DF1706, the Pacific Microsonics PMD200, or a programmable digital signal processor.

In the external DF mode, LRCK (pin 4), BCK (pin 6) and DATA (pin 5) are defined as WDCK, the word clock; BCK, the bit clock; and DATA, the monaural data. The external digital filter interface is selected by using the DFTH bit of control register 20, which functions to bypass the internal digital filter of the PCM1796.

When the DFMS bit of control register 19 is set, the PCM1796 can process stereo data. In this case, ZEROL (pin 1) and ZEROR (pin 2) are defined as L-channel data and R-channel data input, respectively.

Detailed information for the external digital filter interface mode is provided in the *APPLICATION FOR EXTERNAL DIGITAL FILTER INTERFACE* section of this data sheet.

## Direct Stream Digital (DSD) Format Interface and Timing

The PCM1796 supports the DSD format interface operation, which includes out-of-band noise filtering using an internal analog FIR filter. For DSD operation, SCK (pin 7) is redefined as BCK, DATA (pin 5) as DATAL (left channel audio data), and LRCK (pin 4) as DATAR (right channel audio data). BCK (pin 6) must be forced low in the DSD mode. The DSD format interface is activated by setting the DSD bit of control register 20.

Detailed information for the DSD mode is provided in the *APPLICATION FOR DSD FORMAT (DSD MODE) INTERFACE* section of this data sheet.

## TDMCA Interface

The PCM1796 supports the time-division-multiplexed command and audio (TDMCA) data format to enable control of and communication with a number of external devices over a single serial interface.

Detailed information for the TDMCA format is provided in the *TDMCA INTERFACE FORMAT* section of this data sheet.

## FUNCTION DESCRIPTIONS

### Zero Detect

The PCM1796 has a zero-detect function. When the PCM1796 detects the zero conditions as shown in Table 2, the PCM1796 sets ZEROL (pin 1) and ZEROR (pin 2) to HIGH.

**Table 2. Zero Conditions**

MODE		DETECTING CONDITION AND TIME
PCM		DATA is continuously LOW for 1024 LRCKs.
External DF Mode		DATA is continuously LOW for 1024 WDCKs.
DSD	DZ0	There are an equal number of 1s and 0s in every 8 bits of DSD input data for 23 ms.
	DZ1	The input data is 1001 0110 continuously for 23 ms.

## SERIAL CONTROL INTERFACE

The PCM1796 supports SPI and I<sup>2</sup>C that sets mode control registers as shown in Table 4. This serial control interface is selected by MSEL (pin 3), SPI is activated when MSEL is set to LOW, and I<sup>2</sup>C is activated when MSEL is set to HIGH.

### SPI Interface

The SPI interface is a 4-wire synchronous serial port that operates asynchronously to the serial audio interface and the system clock (SCK). The serial control interface is used to program and read the on-chip mode registers. The control interface includes MDO (pin 13), MDI (pin 11), MC (pin 12), and MS (pin 10). MDO is the serial data output, used to read back the values of the mode registers; MDI is the serial data input, used to program the mode registers; MC is the serial bit clock, used to shift data in and out of the control port, and MS is the mode control enable, used to enable the internal mode register access.

### Register Read/Write Operation

All read/write operations for the serial control port use 16-bit data words. Figure 28 shows the control data word format. The most significant bit is the read/write (R/W) bit. For write operations, the R/W bit must be set to 0. For read operations, the R/W bit must be set to 1. There are seven bits, labeled IDX[6:0], that hold the register index (or address) for the read and write operations. The least significant eight bits, D[7:0], contain the data to be written to, or the data that was read from, the register specified by IDX[6:0].

Figure 29 shows the functional timing diagram for writing or reading the serial control port. MS is held at a logic 1 state until a register needs to be written or read. To start the register write or read cycle, MS is set to logic 0. Sixteen clocks are then provided on MC, corresponding to the 16 bits of the control data word on MDI and readback data on MDO. After the eighth clock cycle has completed, the data from the indexed-mode control register appears on MDO during the read operation. After the sixteenth clock cycle has completed, the data is latched into the indexed-mode control register during the write operation. To write or read subsequent data, MS must be set to 1 once.

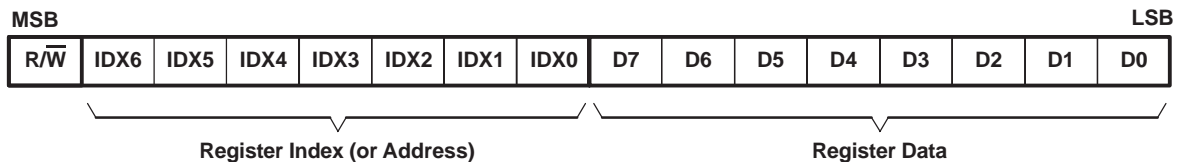
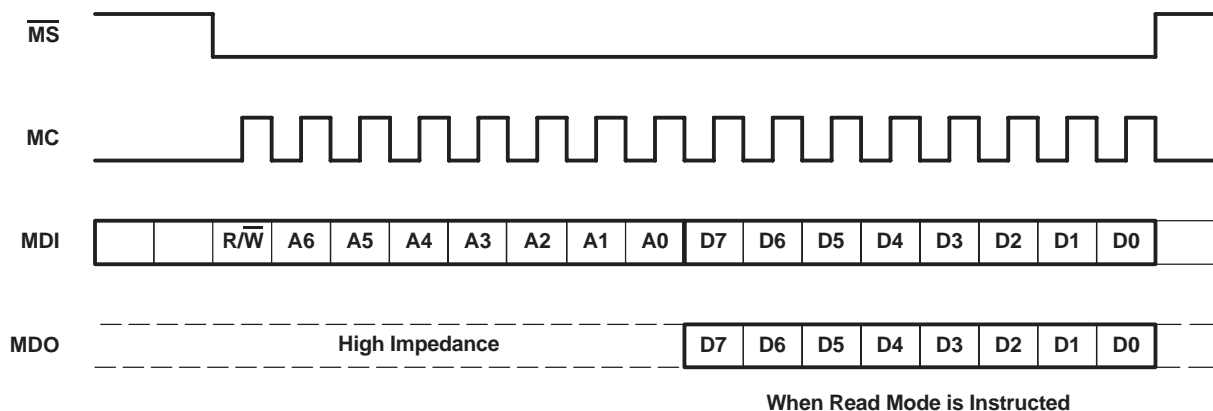
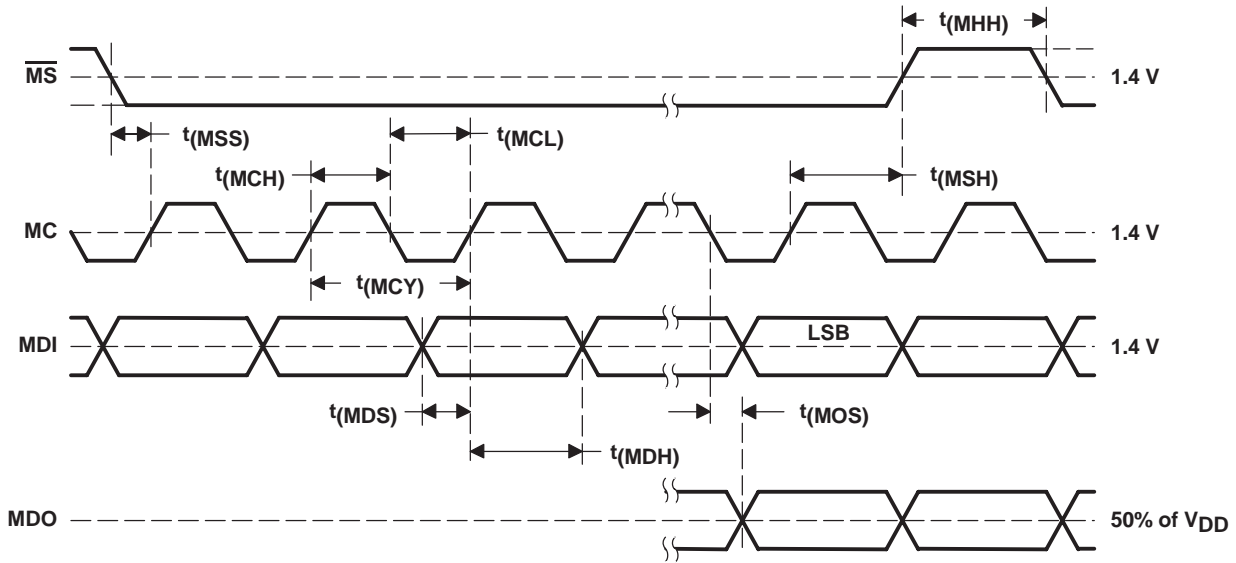

Figure 28. Control Data Word Format for MDI



NOTE: Bit 15 is used for selection of write or read. Setting R/W = 0 indicates a write, while R/W = 1 indicates a read. Bits 14–8 are used for the register address. Bits 7–0 are used for register data.

Figure 29. Serial Control Format



PARAMETER	MIN	MAX	UNITS
t(MCY) MC pulse cycle time	100		ns
t(MCL) MC low-level time	40		ns
t(MCH) MC high-level time	40		ns
t(MHH) MS-bar high-level time	80		ns
t(MSS) MS-bar falling edge to MC rising edge	15		ns
t(MSH) MS-bar hold time <sup>(1)</sup>	15		ns
t(MDH) MDI hold time	15		ns
t(MDS) MDI setup time	15		ns
t(MOS) MC falling edge to MDO stable		30	ns

<sup>(1)</sup> MC rising edge for LSB to MS rising edge

**Figure 30. Control Interface Timing**

## I<sup>2</sup>C INTERFACE

The PCM1796 supports the I<sup>2</sup>C serial bus and the data transmission protocol for standard and fast mode as a slave device. This protocol is explained in I<sup>2</sup>C specification 2.0.

In I<sup>2</sup>C mode, the control terminals are changed as follows.

TERMINAL NAME	TDMCA NAME	PROPERTY	DESCRIPTION
$\overline{MS}$	ADR0	Input	I <sup>2</sup> C address 0
MDI	ADR1	Input	I <sup>2</sup> C address 1
MC	SCL	Input	I <sup>2</sup> C clock
MDO	SDA	Input/output	I <sup>2</sup> C data

### Slave Address

MSB							LSB
1	0	0	1	1	ADR1	ADR0	R/ $\overline{W}$

The PCM1796 has 7 bits for its own slave address. The first five bits (MSBs) of the slave address are factory preset to 10011. The next two bits of the address byte are the device select bits which can be user-defined by the ADR1 and ADR0 terminals. A maximum of four PCM1796s can be connected on the same bus at one time. Each PCM1796 responds when it receives its own slave address.

### Packet Protocol

A master device must control packet protocol, which consists of start condition, slave address, read/write bit, data if write or acknowledge if read, and stop condition. The PCM1796 supports only slave receivers and slave transmitters.

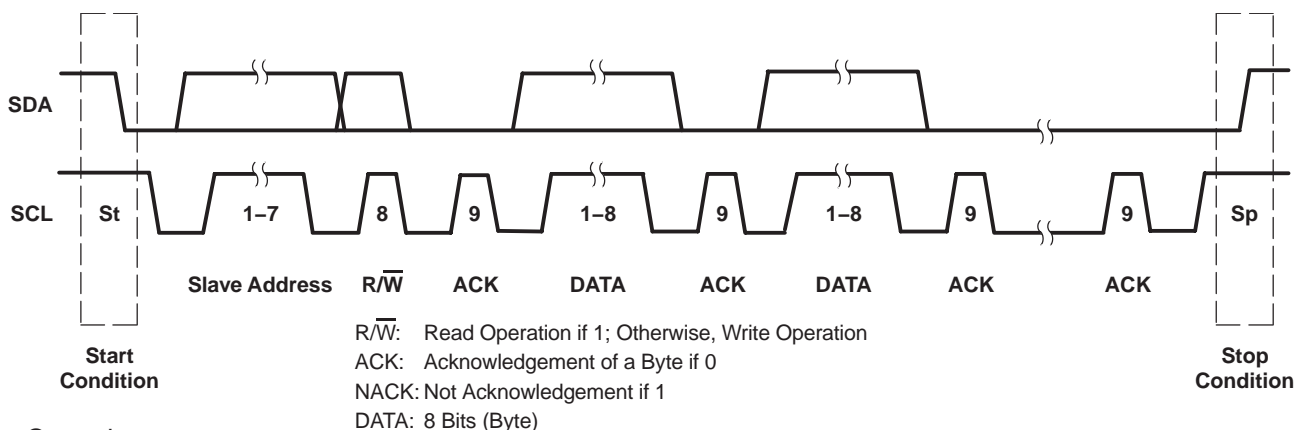

#### Write Operation

Transmitter	M	M	M	S	M	S	M	S		S	M
Data Type	St	Slave Address	$\overline{W}$	ACK	DATA	ACK	DATA	ACK		ACK	Sp

#### Read Operation

Transmitter	M	M	M	S	S	M	S	M		M	M
Data Type	St	Slave Address	R	ACK	DATA	ACK	DATA	ACK		NACK	Sp

M: Master Device

S: Slave Device

St: Start Condition

Sp: Stop Condition

$\overline{W}$ : Write

R: Read

ACK: Acknowledge

NACK: Not Acknowledge

Figure 31. Basic I<sup>2</sup>C Framework

### Write Register

A master can write to any PCM1796 registers using single or multiple accesses. The master sends a PCM1796 slave address with a write bit, a register address, and the data. If multiple access is required, the address is that of the starting register, followed by the data to be transferred. When the data are received properly, the index register is incremented by 1 automatically. When the index register reaches 0x7F, the next value is 0x00. When undefined registers are accessed, the PCM1796 does not send an acknowledgement. Figure 32 is a diagram of the write operation.

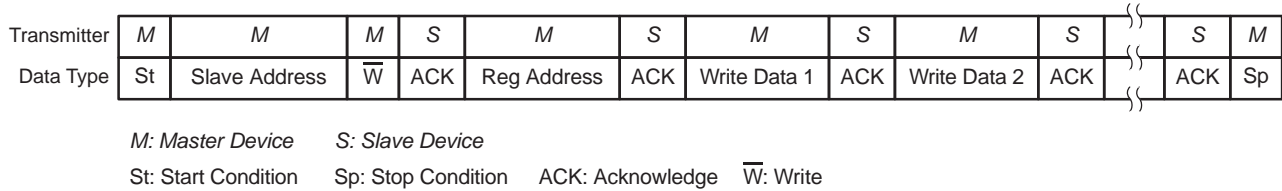

**Figure 32. Write Operation**

### Read Register

A master can read the PCM1796 register. The value of the register address is stored in an indirect index register in advance. The master sends a PCM1796 slave address with a read bit after storing the register address. Then the PCM1796 transfers the data which the index register points to. When the data are transferred during a multiple access, the index register is incremented by 1 automatically. (When first going into read mode immediately following a write, the index register is not incremented. The master can read the register that was previously written.) When the index register reaches 0x7F, the next value is 0x00. The PCM1796 outputs some data when the index register is 0x10 to 0x1F, even if it is not defined in Table 4. Figure 33 is a diagram of the read operation.

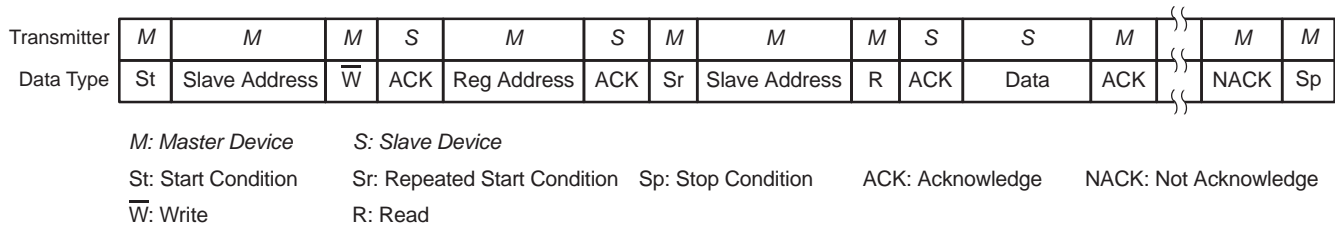

**Figure 33. Read Operation**

## Noise Suppression

The PCM1796 incorporates noise suppression using the system clock (SCK). However, there must be no more than two noise spikes in 600 ns. The noise suppression works for SCK frequencies between 8 MHz and 40 MHz in fast mode. However, it works incorrectly in the following conditions.

### Case 1:

1.  $t_{(SCK)} > 120 \text{ ns}$  ( $t_{(SCK)}$ : period of SCK)
2.  $t_{(HI)} + t_{(D-HD)} < t_{(SCK)} \times 5$
3. Spike noise exists on the first half of the SCL HIGH pulse.
4. Spike noise exists on the SDA HIGH pulse just before SDA goes LOW.

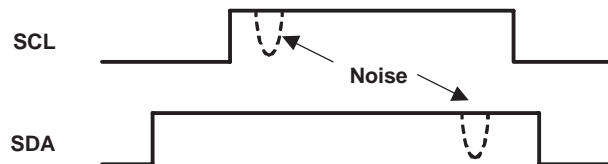

When these conditions occur at the same time, the data is recognized as LOW.

### Case 2:

1.  $t_{(SCK)} > 120 \text{ ns}$
2.  $t_{(S-HD)}$  or  $t_{(RS-HD)} < t_{(SCK)} \times 5$
3. Spike noise exists on both SCL and SDA during the hold time.

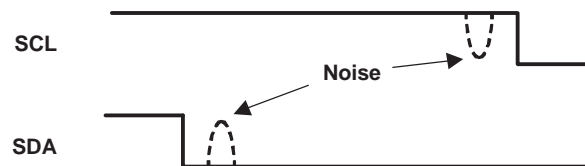

When these conditions occur at the same time, the PCM1796 fails to detect a start condition.

### Case 3:

1.  $t_{(SCK)} < 50 \text{ ns}$
2.  $t_{(SP)} > t_{(SCK)}$
3. Spike noise exists on SCL just after SCL goes LOW.
4. Spike noise exists on SDA just before SCL goes LOW.

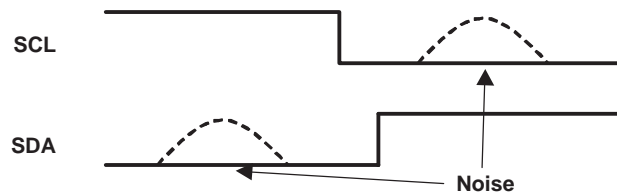

When these conditions occur at the same time, the PCM1796 erroneously detects a start or stop condition.

**TIMING DIAGRAM**

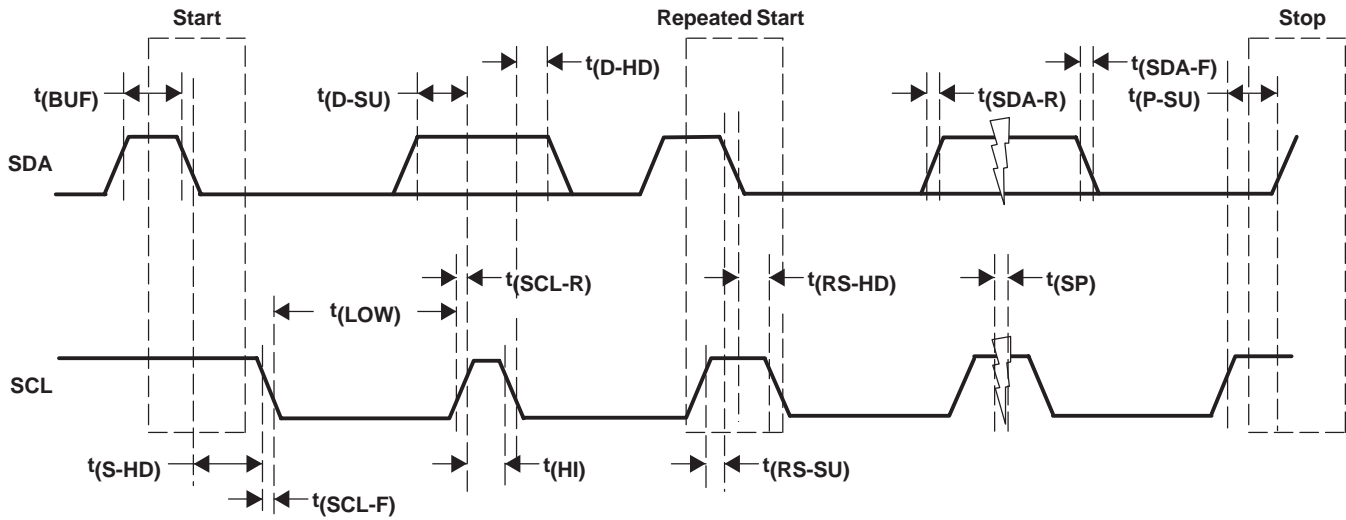

**TIMING CHARACTERISTICS**

PARAMETER		CONDITIONS	MIN	MAX	UNIT
f(SCL)	SCL clock frequency	Standard		100	kHz
		Fast		400	
t(BUF)	Bus free time between stop and start conditions	Standard	4.7		μs
		Fast	1.3		
t(LOW)	Low period of the SCL clock	Standard	4.7		μs
		Fast	1.3		
t(HI)	High period of the SCL clock	Standard	4		μs
		Fast	600		
t(RS-SU)	Setup time for (repeated) start condition	Standard	4.7		μs
		Fast	600		
t(S-HD)	Hold time for (repeated) start condition	Standard	4		μs
t(RS-HD)		Fast	600		ns
t(D-SU)	Data setup time	Standard	250		ns
		Fast	100		
t(D-HD)	Data hold time	Standard	0	900	ns
		Fast	0	900	
t(SCL-R)	Rise time of SCL signal	Standard	20 + 0.1 C <sub>B</sub>	1000	ns
		Fast	20 + 0.1 C <sub>B</sub>	300	
t(SCL-R1)	Rise time of SCL signal after a repeated start condition and after an acknowledge bit	Standard	20 + 0.1 C <sub>B</sub>	1000	ns
		Fast	20 + 0.1 C <sub>B</sub>	300	
t(SCL-F)	Fall time of SCL signal	Standard	20 + 0.1 C <sub>B</sub>	1000	ns
		Fast	20 + 0.1 C <sub>B</sub>	300	
t(SDA-R)	Rise time of SDA signal	Standard	20 + 0.1 C <sub>B</sub>	1000	ns
		Fast	20 + 0.1 C <sub>B</sub>	300	
t(SDA-F)	Fall time of SDA signal	Standard	20 + 0.1 C <sub>B</sub>	1000	ns
		Fast	20 + 0.1 C <sub>B</sub>	300	
t(P-SU)	Setup time for stop condition	Standard	4		μs
		Fast	600		
C <sub>(B)</sub>	Capacitive load for SDA and SCL line			400	pF
t(SP)	Pulse duration of suppressed spike	Fast		50	ns
V <sub>NH</sub>	Noise margin at high level for each connected device (including hysteresis)			0.2 V <sub>DD</sub>	V

**Figure 34. Timing Definition on the I<sup>2</sup>C Bus**



## MODE CONTROL REGISTERS

### User-Programmable Mode Controls

The PCM1796 includes a number of user-programmable functions which are accessed via mode control registers. The registers are programmed using the serial control interface, which is previously discussed in the *SPI Interface* and *I<sup>2</sup>C INTERFACE* sections of this data sheet. Table 3 lists the available mode-control functions, along with their default reset conditions and associated register index.

**Table 3. User-Programmable Function Controls**

FUNCTION	DEFAULT	REGISTER	BIT	PCM	DSD	DF BYPASS
Digital attenuation control 0 dB to –120 dB and mute, 0.5 dB step	0 dB	Register 16 Register 17	ATL[7:0] (for L-ch) ATR[7:0] (for R-ch)	yes		
Attenuation load control Disabled, enabled	Attenuation disabled	Register 18	ATLD	yes		
Input audio data format selection 16-, 20-, 24-bit standard (right-justified) format 24-bit MSB-first left-justified format 16-/24-bit I <sup>2</sup> S format	24-bit I <sup>2</sup> S format	Register 18	FMT[2:0]	yes		yes
Sampling rate selection for de-emphasis Disabled, 44.1 kHz, 48 kHz, 32 kHz	De-emphasis disabled	Register 18	DMF[1:0]	yes	yes <sup>(1)</sup>	
De-emphasis control Disabled, enabled	De-emphasis disabled	Register 18	DME	yes		
Soft mute control Soft mute disabled, enabled	Mute disabled	Register 18	MUTE	yes		
Output phase reversal Normal, reverse	Normal	Register 19	REV	yes	yes	yes
Attenuation speed selection $\times 1f_s$ , $\times (1/2)f_s$ , $\times (1/4)f_s$ , $\times (1/8)f_s$	$\times 1f_s$	Register 19	ATS[1:0]	yes		
DAC operation control Enabled, disabled	DAC operation enabled	Register 19	OPE	yes	yes	yes
Stereo DF bypass mode select Monaural, stereo	Monaural	Register 19	DFMS			yes
Digital filter rolloff selection Sharp rolloff, slow rolloff	Sharp rolloff	Register 19	FLT	yes		
Infinite zero mute control Disabled, enabled	Disabled	Register 19	INZD	yes		yes
System reset control Reset operation, normal operation	Normal operation	Register 20	SRST	yes	yes	yes
DSD interface mode control DSD enabled, disabled	Disabled	Register 20	DSD	yes	yes	
Digital-filter bypass control DF enabled, DF bypass	DF enabled	Register 20	DFTH	yes		yes
Monaural mode selection Stereo, monaural	Stereo	Register 20	MONO	yes	yes	yes
Channel selection for monaural mode data L-channel, R-channel	L-channel	Register 20	CHSL	yes	yes	yes
Delta-sigma oversampling rate selection $\times 64f_s$ , $\times 128f_s$ , $\times 32f_s$	$\times 64f_s$	Register 20	OS[1:0]	yes	yes <sup>(2)</sup>	yes
PCM zero output enable	Enabled	Register 21	PCMZ	yes		yes
DSD zero output enable	Disabled	Register 21	DZ[1:0]		yes	
<b>FUNCTION AVAILABLE ONLY FOR READ</b>						
Zero detection flag Not zero, zero detected	Not zero = 0 Zero detected = 1	Register 22	ZFGL (for L-ch) ZFGR (for R-ch)	yes	yes	yes
Device ID (at TDMCA)	–	Register 23	ID[4:0]	yes		

<sup>(1)</sup> When in DSD mode, DMF[1:0] is defined as DSD filter (analog FIR) performance selection.

<sup>(2)</sup> When in DSD mode, OS[1:0] is defined as DSD filter (analog FIR) operation rate selection.

## Register Map

The mode control register map is shown in Table 4. Registers 16–21 include an  $R/\overline{W}$  bit, which determines whether a register read ( $R/\overline{W} = 1$ ) or write ( $R/\overline{W} = 0$ ) operation is performed. Registers 22 and 23 are read-only.

**Table 4. Mode Control Register Map**

	B15	B14	B13	B12	B11	B10	B9	B8	B7	B6	B5	B4	B3	B2	B1	B0
Register 16	$R/\overline{W}$	0	0	1	0	0	0	0	ATL7	ATL6	ATL5	ATL4	ATL3	ATL2	ATL1	ATL0
Register 17	$R/\overline{W}$	0	0	1	0	0	0	1	ATR7	ATR6	ATR5	ATR4	ATR3	ATR2	ATR1	ATR0
Register 18	$R/\overline{W}$	0	0	1	0	0	1	0	ATLD	FMT2	FMT1	FMT0	DMF1	DMF0	DME	MUTE
Register 19	$R/\overline{W}$	0	0	1	0	0	1	1	REV	ATS1	ATS0	OPE	RSV	DFMS	FLT	INZD
Register 20	$R/\overline{W}$	0	0	1	0	1	0	0	RSV	SRST	DSD	DFTH	MONO	CHSL	OS1	OS0
Register 21	$R/\overline{W}$	0	0	1	0	1	0	1	RSV	RSV	RSV	RSV	RSV	DZ1	DZ0	PCMZ
Register 22	R	0	0	1	0	1	1	0	RSV	RSV	RSV	RSV	RSV	RSV	ZFGR	ZFGL
Register 23	R	0	0	1	0	1	1	1	RSV	RSV	RSV	ID4	ID3	ID2	ID1	ID0

## Register Definitions

	B15	B14	B13	B12	B11	B10	B9	B8	B7	B6	B5	B4	B3	B2	B1	B0
Register 16	$R/\overline{W}$	0	0	1	0	0	0	0	ATL7	ATL6	ATL5	ATL4	ATL3	ATL2	ATL1	ATL0
Register 17	$R/\overline{W}$	0	0	1	0	0	0	1	ATR7	ATR6	ATR5	ATR4	ATR3	ATR2	ATR1	ATR0

### $R/\overline{W}$ : Read/Write Mode Select

When  $R/\overline{W} = 0$ , a write operation is performed.

When  $R/\overline{W} = 1$ , a read operation is performed.

Default value: 0

### ATx[7:0]: Digital Attenuation Level Setting

These bits are available for read and write.

Default value: 1111 1111b

Each DAC output has a digital attenuator associated with it. The attenuator can be set from 0 dB to –120 dB, in 0.5-dB steps. Alternatively, the attenuator can be set to infinite attenuation (or mute).

The attenuation data for each channel can be set individually. However, the data load control (the ATLD bit of control register 18) is common to both attenuators. ATLD must be set to 1 in order to change an attenuator setting. The attenuation level can be set using the following formula:

$$\text{Attenuation level (dB)} = 0.5 \text{ dB} \cdot (\text{ATx}[7:0]_{\text{DEC}} - 255)$$

where  $\text{ATx}[7:0]_{\text{DEC}} = 0$  through 255

For  $\text{ATx}[7:0]_{\text{DEC}} = 0$  through 14, the attenuator is set to infinite attenuation. The following table shows attenuation levels for various settings:

ATx[7:0]	Decimal Value	Attenuation Level Setting
1111 1111b	255	0 dB, no attenuation (default)
1111 1110b	254	–0.5 dB
1111 1101b	253	–1.0 dB
⋮	⋮	⋮
0001 0000b	16	–119.5 dB
0000 1111b	15	–120.0 dB
0000 1110b	14	Mute
⋮	⋮	⋮
0000 0000b	0	Mute

	<b>B15</b>	<b>B14</b>	<b>B13</b>	<b>B12</b>	<b>B11</b>	<b>B10</b>	<b>B9</b>	<b>B8</b>	<b>B7</b>	<b>B6</b>	<b>B5</b>	<b>B4</b>	<b>B3</b>	<b>B2</b>	<b>B1</b>	<b>B0</b>
Register 18	R/ $\overline{W}$	0	0	1	0	0	1	0	ATLD	FMT2	FMT1	FMT0	DMF1	DMF0	DME	MUTE

**R/ $\overline{W}$ : Read/Write Mode Select**

When R/ $\overline{W}$  = 0, a write operation is performed.

When R/ $\overline{W}$  = 1, a read operation is performed.

Default value: 0

**ATLD: Attenuation Load Control**

This bit is available for read and write.

Default value: 0

ATLD = 0	Attenuation control disabled (default)
ATLD = 1	Attenuation control enabled

The ATLD bit is used to enable loading of the attenuation data contained in registers 16 and 17. When ATLD = 0, the attenuation settings remain at the previously programmed levels, ignoring new data loaded from registers 16 and 17. When ATLD = 1, attenuation data written to registers 16 and 17 is loaded normally.

**FMT[2:0]: Audio Interface Data Format**

These bits are available for read and write.

Default value: 101

<b>FMT[2:0]</b>	<b>Audio Data Format Selection</b>
000	16-bit standard format, right-justified data
001	20-bit standard format, right-justified data
010	24-bit standard format, right-justified data
011	24-bit MSB-first, left-justified format data
100	16-bit I <sup>2</sup> S format data
101	24-bit I <sup>2</sup> S format data (default)
110	Reserved
111	Reserved

The FMT[2:0] bits are used to select the data format for the serial audio interface.

For the external digital filter interface mode (DFTH mode), this register is operated as shown in the *APPLICATION FOR EXTERNAL DIGITAL FILTER INTERFACE* section of this data sheet.

**DMF[1:0]: Sampling Frequency Selection for the De-Emphasis Function**

These bits are available for read and write.

Default value: 00

<b>DMF[1:0]</b>	<b>De-Emphasis Sampling Frequency Selection</b>
00	Disabled (default)
01	48 kHz
10	44.1 kHz
11	32 kHz

The DMF[1:0] bits are used to select the sampling frequency used by the digital de-emphasis function when it is enabled by setting the DME bit. The de-emphasis curves are shown in the *TYPICAL PERFORMANCE CURVES* section of this data sheet.

For the DSD mode, analog FIR filter performance can be selected using this register. A register map and filter response plots are shown in the *APPLICATION FOR DSD FORMAT (DSD MODE) INTERFACE* section of this data sheet.

**DME: Digital De-Emphasis Control**

This bit is available for read and write.

Default value: 0

DME = 0	De-emphasis disabled (default)
DME = 1	De-emphasis enabled

The DME bit is used to enable or disable the de-emphasis function for both channels.

**MUTE: Soft Mute Control**

This bit is available for read and write.

Default value: 0

MUTE = 0	Soft mute disabled (default)
MUTE = 1	Soft mute enabled

The MUTE bit is used to enable or disable the soft mute function for both channels.

Soft mute is operated as a 256-step attenuator. The speed for each step to  $-\infty$  dB (mute) is determined by the attenuation rate selected in the ATS register.

	<b>B15</b>	<b>B14</b>	<b>B13</b>	<b>B12</b>	<b>B11</b>	<b>B10</b>	<b>B9</b>	<b>B8</b>	<b>B7</b>	<b>B6</b>	<b>B5</b>	<b>B4</b>	<b>B3</b>	<b>B2</b>	<b>B1</b>	<b>B0</b>
Register 19	R/W	0	0	1	0	0	1	1	REV	ATS1	ATS0	OPE	RSV	DFMS	FLT	INZD

**R/W: Read/Write Mode Select**

When  $R/\overline{W} = 0$ , a write operation is performed.

When  $R/\overline{W} = 1$ , a read operation is performed.

Default value: 0

**REV: Output Phase Reversal**

This bit is available for read and write.

Default value: 0

REV = 0	Normal output (default)
REV = 1	Inverted output

The REV bit is used to invert the output phase for both channels.

**ATS[1:0]: Attenuation Rate Select**

These bits are available for read and write.

Default value: 00

ATS[1:0]	Attenuation Rate Selection
00	Every LRCK (default)
01	LRCK/2
10	LRCK/4
11	LRCK/8

The ATS[1:0] bits are used to select the rate at which the attenuator is decremented/incremented during level transitions.

**OPE: DAC Operation Control**

This bit is available for read and write.

Default value: 0

OPE = 0	DAC operation enabled (default)
OPE = 1	DAC operation disabled

The OPE bit is used to enable or disable the analog output for both channels. Disabling the analog outputs forces them to the bipolar zero level (BPZ) even if audio data is present on the input.

**DFMS: Stereo DF Bypass Mode Select**

This bit is available for read and write.

Default value: 0

DFMS = 0	Monaural (default)
DFMS = 1	Stereo input enabled

The DFMS bit is used to enable stereo operation in DF bypass mode. In the DF bypass mode, when DFMS is set to 0, the pin for the input data is DATA (pin 5) only, therefore the PCM1796 operates as a monaural DAC. When DFMS is set to 1, the PCM1796 can operate as a stereo DAC with inputs of L-channel and R-channel data on ZEROL (pin 1) and ZEROR (pin 2), respectively.

**FLT: Digital Filter Rolloff Control**

This bit is available for read and write.

Default value: 0

FLT = 0	Sharp rolloff (default)
FLT = 1	Slow rolloff

The FLT bit is used to select the digital filter rolloff characteristic. The filter responses for these selections are shown in the *TYPICAL PERFORMANCE CURVES* section of this data sheet.

**INZD: Infinite Zero Detect Mute Control**

This bit is available for read and write.

Default value: 0

INZD = 0	Infinite zero detect mute disabled (default)
INZD = 1	Infinite zero detect mute enabled

The INZD bit is used to enable or disable the zero detect mute function. Setting INZD to 1 forces muted analog outputs to hold a bipolar zero level when the PCM1796 detects a zero condition in both channels. The infinite zero detect mute function is not available in the DSD mode.

	B15	B14	B13	B12	B11	B10	B9	B8	B7	B6	B5	B4	B3	B2	B1	B0
Register 20	R/W	0	0	1	0	1	0	0	RSV	SRST	DSD	DFTH	MONO	CHSL	OS1	OS0

**R/W: Read/Write Mode Select**

When  $R/\overline{W} = 0$ , a write operation is performed.

When  $R/\overline{W} = 1$ , a read operation is performed.

Default value: 0

**SRST: System Reset Control**

This bit is available for write only.

Default value: 0

SRST = 0	Normal operation (default)
SRST = 1	System reset operation (generate one reset pulse)

The SRST bit is used to reset the PCM1796 to the initial system condition.

**DSD: DSD Interface Mode Control**

This bit is available for read and write.

Default value: 0

DSD = 0	DSD interface mode disabled (default)
DSD = 1	DSD interface mode enabled

The DSD bit is used to enable or disable the DSD interface mode.

**DFTH: Digital Filter Bypass (or Through Mode) Control**

This bit is available for read and write.

Default value: 0

DFTH = 0	Digital filter enabled (default)
DFTH = 1	Digital filter bypassed for external digital filter

The DFTH bit is used to enable or disable the external digital filter interface mode.

**MONO: Monaural Mode Selection**

This bit is available for read and write.

Default value: 0

MONO = 0	Stereo mode (default)
MONO = 1	Monaural mode

The MONO function is used to change operation mode from the normal stereo mode to the monaural mode. When the monaural mode is selected, both DACs operate in a balanced mode for one channel of audio input data. Channel selection is available for L-channel or R-channel data, determined by the CHSL bit as described immediately following.

**CHSL: Channel Selection for Monaural Mode**

This bit is available for read and write.

Default value: 0

CHSL = 0	L-channel selected (default)
CHSL = 1	R-channel selected

This bit is available when MONO = 1.

The CHSL bit selects L-channel or R-channel data to be used in monaural mode.

**OS[1:0]: Delta-Sigma Oversampling Rate Selection**

These bits are available for read and write.

Default value: 00

OS[1:0]	Operation Speed Select
00	64 times $f_S$ (default)
01	32 times $f_S$
10	128 times $f_S$
11	Reserved

The OS bits are used to change the oversampling rate of delta-sigma modulation. Use of this function enables the designer to stabilize the conditions at the post low-pass filter for different sampling rates. As an application example, programming to set 128 times in 44.1-kHz operation, 64 times in 96-kHz operation, and 32 times in 192-kHz operation allows the use of only a single type (cutoff frequency) of post low-pass filter. The 128  $f_S$  oversampling rate is not available at sampling rates above 100 kHz. If the 128- $f_S$  oversampling rate is selected, a system clock of more than 256  $f_S$  is required.

In DSD mode, these bits are used to select the speed of the bit clock for DSD data coming into the analog FIR filter.

	B15	B14	B13	B12	B11	B10	B9	B8	B7	B6	B5	B4	B3	B2	B1	B0
Register 21	R/W	0	0	1	0	1	0	1	RSV	RSV	RSV	RSV	RSV	DZ1	DZ0	PCMZ

**R/W: Read/Write Mode Select**

When  $R/\overline{W} = 0$ , a write operation is performed.

When  $R/\overline{W} = 1$ , a read operation is performed.

Default value: 0

**DZ[1:0]: DSD Zero Output Enable**

These bits are available for read and write.

Default value: 00

DZ[1:0]	Zero Output Enable
00	Disabled (default)
01	Even pattern detect
1x	96h pattern detect

The DZ bits are used to enable or disable the output zero flags, and to select the zero pattern in the DSD mode.

**PCMZ: PCM Zero Output Enable**

These bits are available for read and write.

Default value: 1

PCMZ = 0	PCM zero output disabled
PCMZ = 1	PCM zero output enabled (default)

The PCMZ bit is used to enable or disable the output zero flags in the PCM mode and the external DF mode.

	B15	B14	B13	B12	B11	B10	B9	B8	B7	B6	B5	B4	B3	B2	B1	B0
Register 22	R	0	0	1	0	1	1	0	RSV	RSV	RSV	RSV	RSV	RSV	ZFGR	ZFGL

**R: Read Mode Select**

Value is always 1, specifying the readback mode.

**ZFGx: Zero-Detection Flag**

Where x = L or R, corresponding to the DAC output channel. These bits are available only for readback.

Default value: 00

ZFGx = 0	Not zero
ZFGx = 1	Zero detected

These bits show zero conditions. Their status is the same as that of the zero flags at ZEROL (pin 1) and ZEROR (pin 2). See *Zero Detect* in the *FUNCTION DESCRIPTIONS* section.

	B15	B14	B13	B12	B11	B10	B9	B8	B7	B6	B5	B4	B3	B2	B1	B0
Register 23	R	0	0	1	0	1	1	1	RSV	RSV	RSV	ID4	ID3	ID2	ID1	ID0

**R: Read Mode Select**

Value is always 1, specifying the readback mode.

**ID[4:0]: Device ID**

The ID[4:0] bits hold a device ID in the TDMCA mode.



APPLICATION INFORMATION

TYPICAL CONNECTION DIAGRAM IN PCM MODE

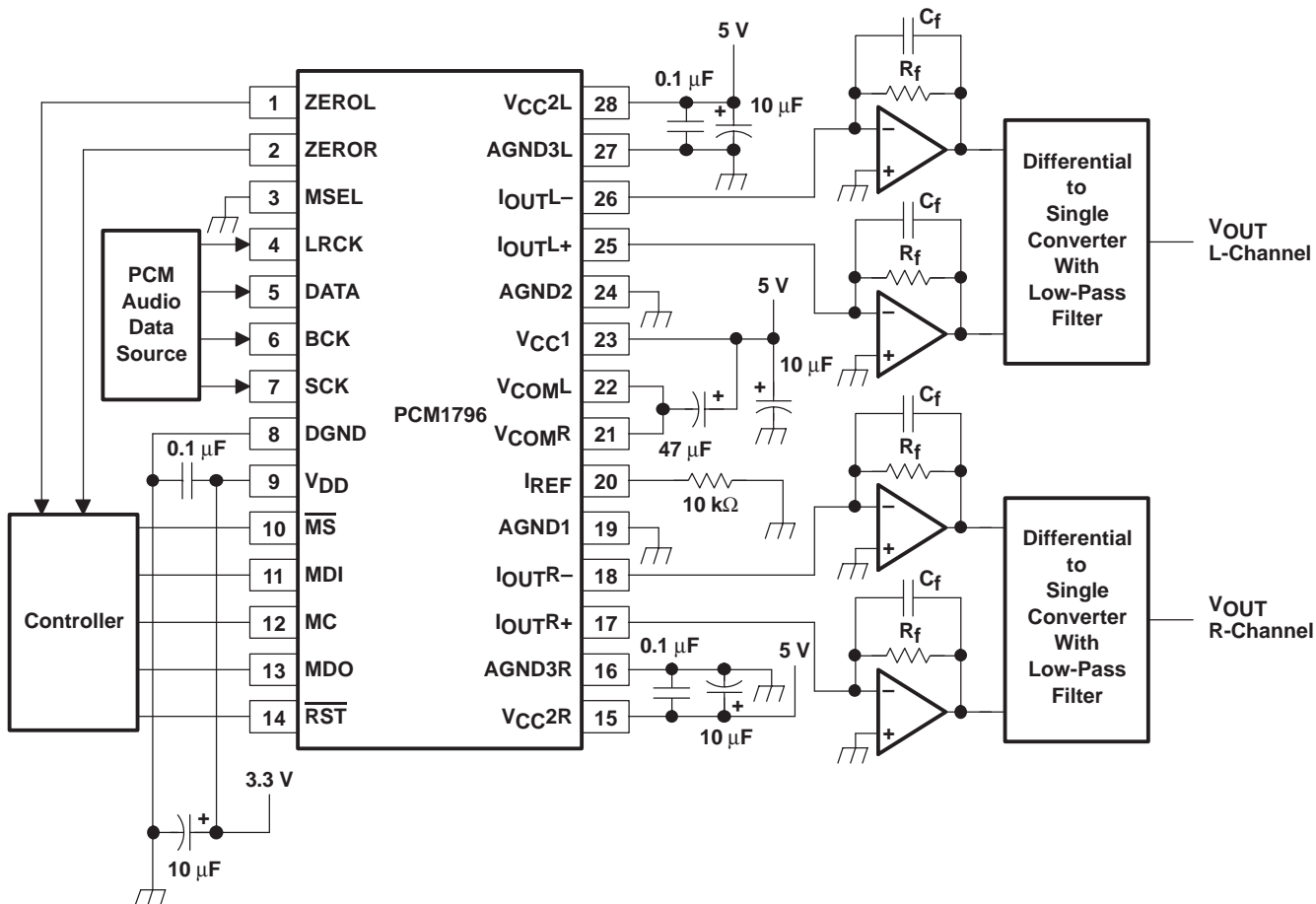

Figure 35. Typical Application Circuit for Standard PCM Audio Operation

APPLICATION CIRCUIT

The design of the application circuit is very important in order to actually realize the high S/N ratio of which the PCM1796 is capable. This is because noise and distortion that are generated in an application circuit are not negligible.

In the third-order LPF circuit of Figure 36, the output level is 2.1 V rms and 123 dB S/N is achieved.

Figure 37 shows a circuit for the DSD mode, which is a fourth-order LPF in order to reduce the out-of-band noise.

I/V Section

The current of the PCM1796 on each of the output pins ( $I_{OUTL+}$ ,  $I_{OUTL-}$ ,  $I_{OUTR+}$ ,  $I_{OUTR-}$ ) is 4 mA p-p at 0 dB (full scale). The voltage output level of the I/V converter ( $V_i$ ) is given by following equation:

$$V_i = 4 \text{ mA p-p} \times R_f \text{ (} R_f \text{ : feedback resistance of I/V converter)}$$

An NE5534 operational amplifier is recommended for the I/V circuit to obtain the specified performance. Dynamic performance such as the gain bandwidth, settling time, and slew rate of the operational amplifier affects the audio dynamic performance of the I/V section.

**Differential Section**

The PCM1796 voltage outputs are followed by differential amplifier stages, which sum the differential signals for each channel, creating a single-ended I/V op-amp output. In addition, the differential amplifiers provide a low-pass filter function.

The operational amplifier recommended for the differential circuit is the low-noise type.

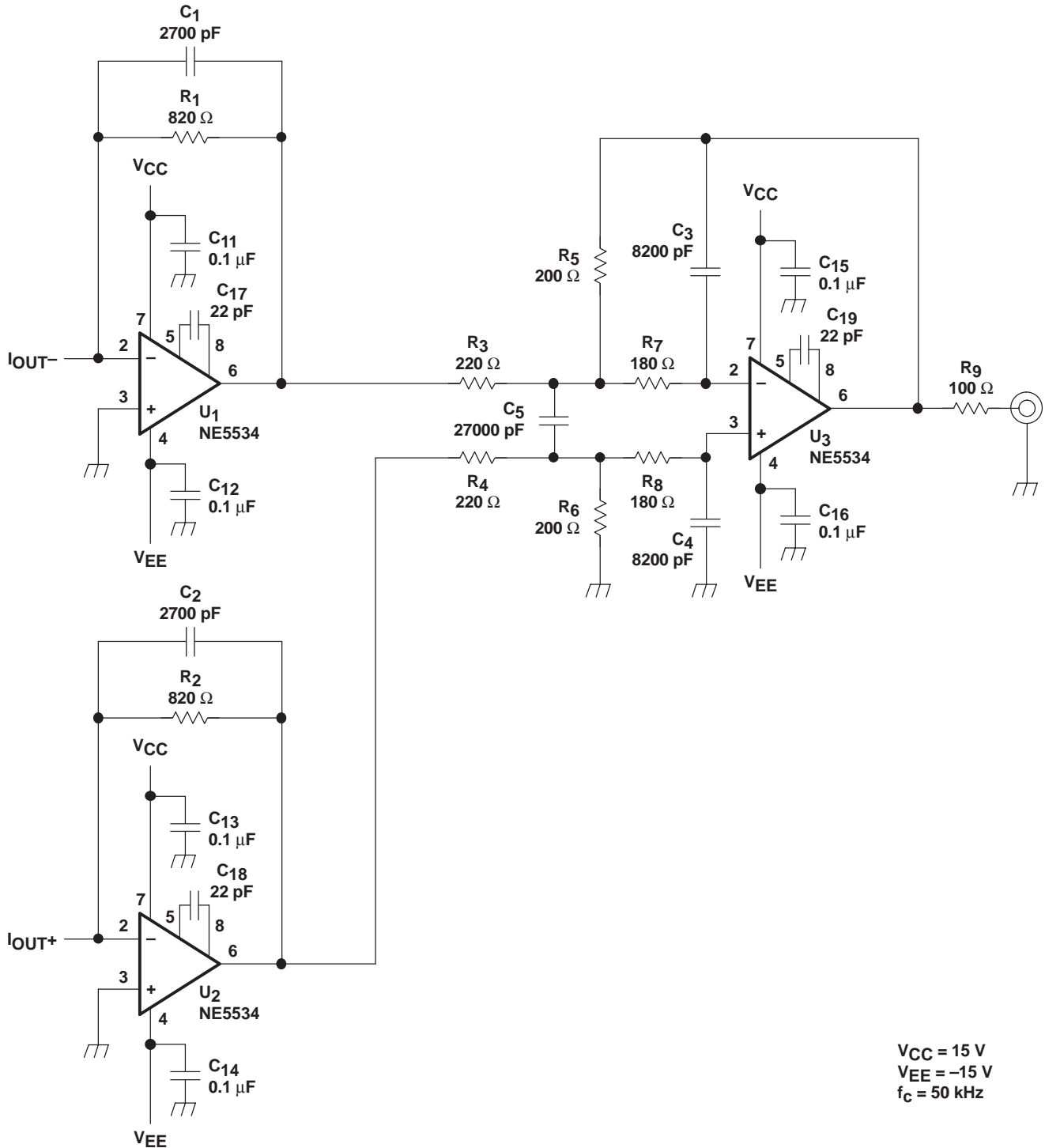

Figure 36. Measurement Circuit for PCM

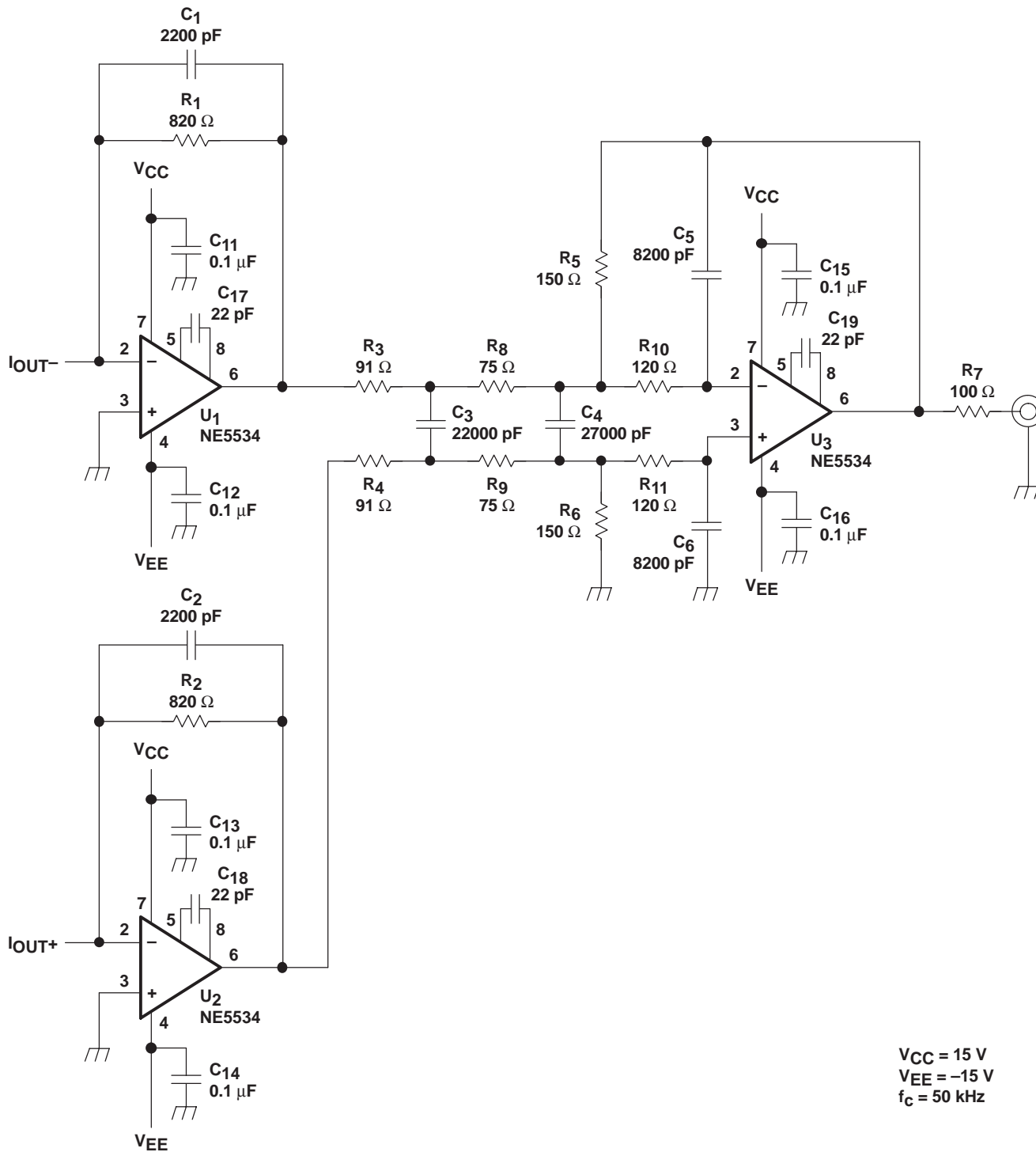

Figure 37. Measurement Circuit for DSD

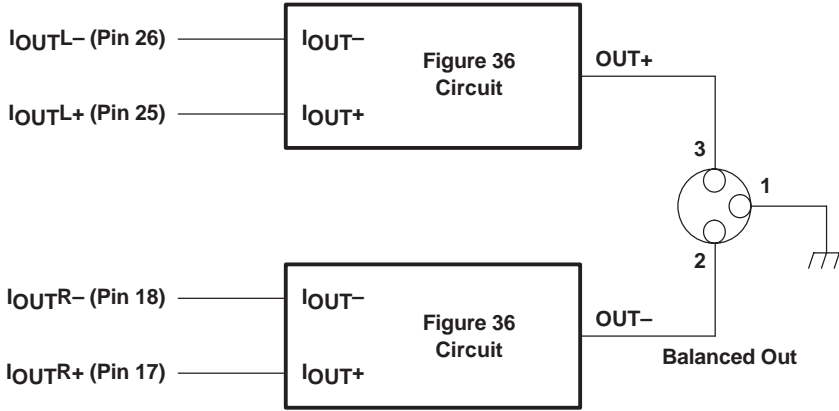
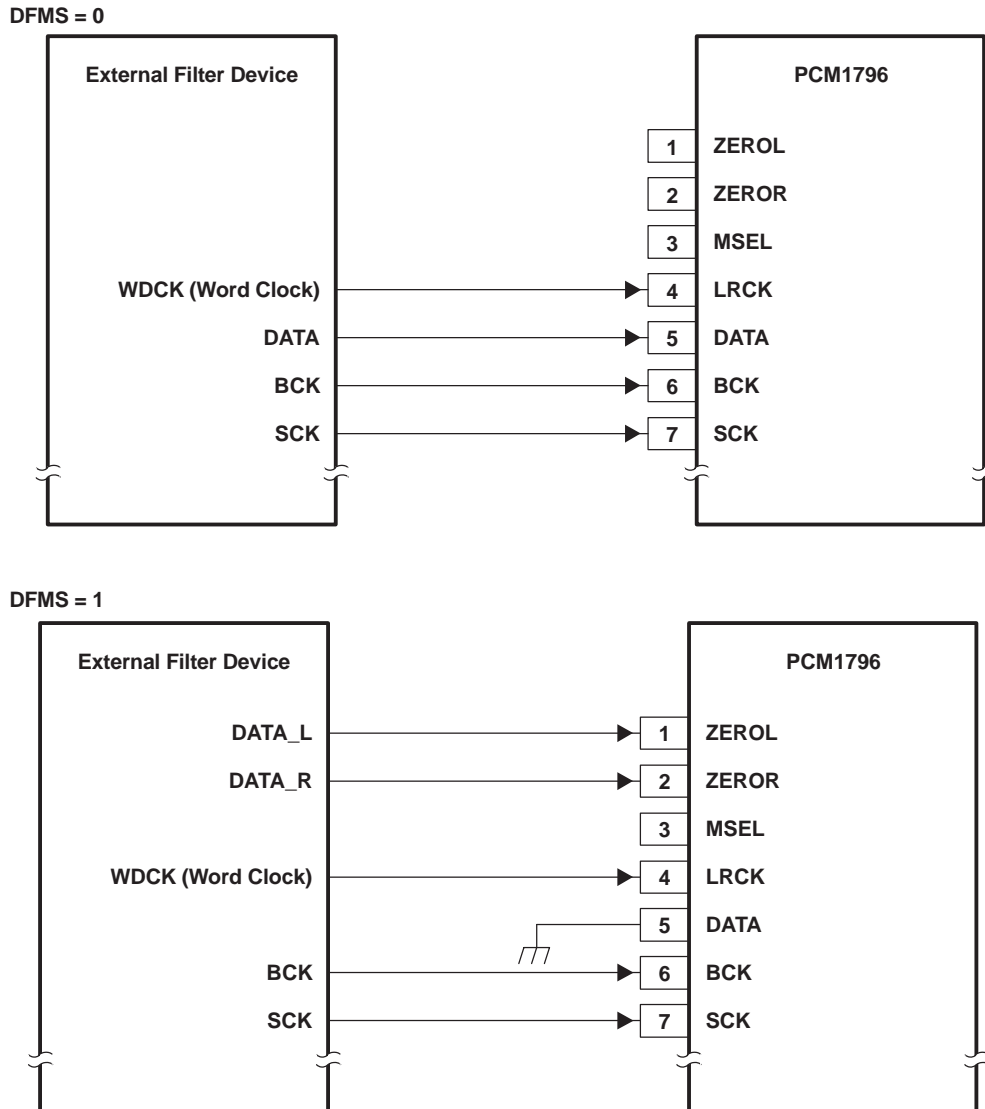

Figure 38. Measurement Circuit for Monaural Mode

**APPLICATION FOR EXTERNAL DIGITAL FILTER INTERFACE**



**Figure 39. Connection Diagram for External Digital Filter (Internal DF Bypass Mode) Application**

### Application for Interfacing With an External Digital Filter

For some applications, it may be desirable to use an external digital filter to perform the interpolation function, as it can provide improved stop-band attenuation when compared to the internal digital filter of the PCM1796.

The PCM1796 supports several external digital filters, including:

- Texas Instruments DF1704 and DF1706
- Pacific Microsonics PMD200 HDCD filter/decoder IC
- Programmable digital signal processors

The external digital filter application mode is accessed by programming the following bits in the corresponding control register:

- DFTH = 1 (register 20)

The pins used to provide the serial interface for the external digital filter are shown in the connection diagram of Figure 39. The word clock (WDCK) signal must be operated at  $8\times$  or  $4\times$  the desired sampling frequency,  $f_s$ .

### Pin Assignment When Using the External Digital Filter Interface

- LRCK (pin 4): WDCK as word clock input
- BCK (pin 6): Bit clock for audio data
- DATA (pin 5): Monaural audio data input when the DFMS bit is not set to 1
- ZEROL (pin 1): DATAL as L-channel audio data input when the DFMS bit is set to 1
- ZEROR (pin 2): DATAR as R-channel audio data input when the DFMS bit is set to 1

## Audio Format

The PCM1796 in the external digital filter interface mode supports right-justified audio formats including 16-bit, 20-bit, and 24-bit audio data, as shown in Figure 40. The audio format is selected by the FMT[2:0] bits of control register18.

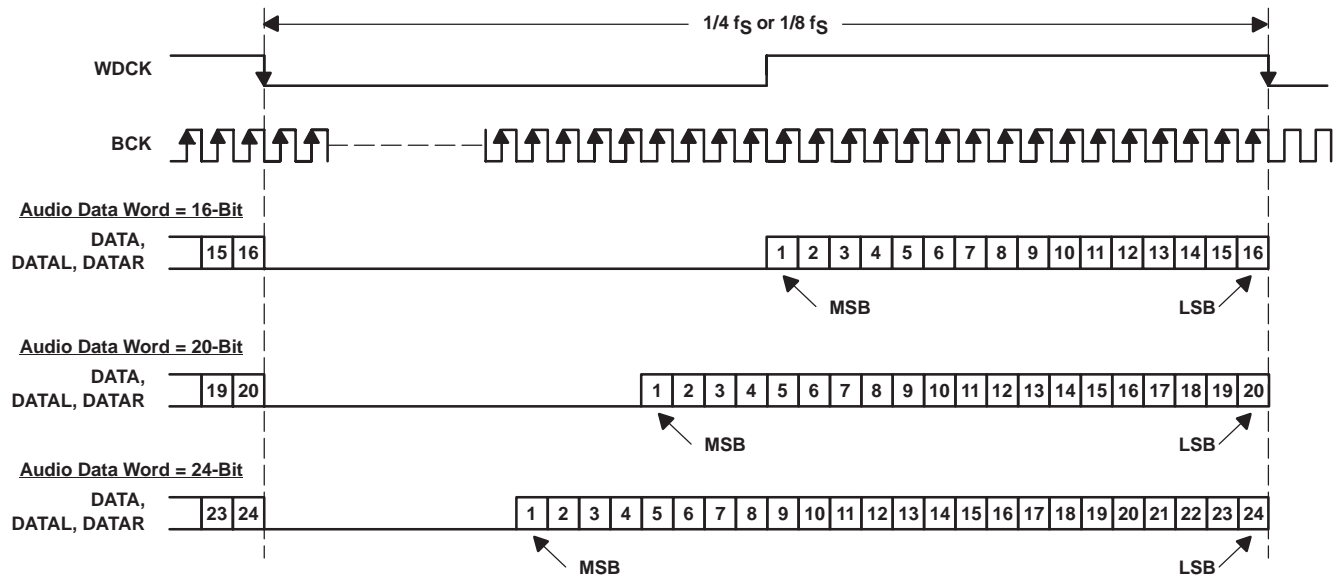
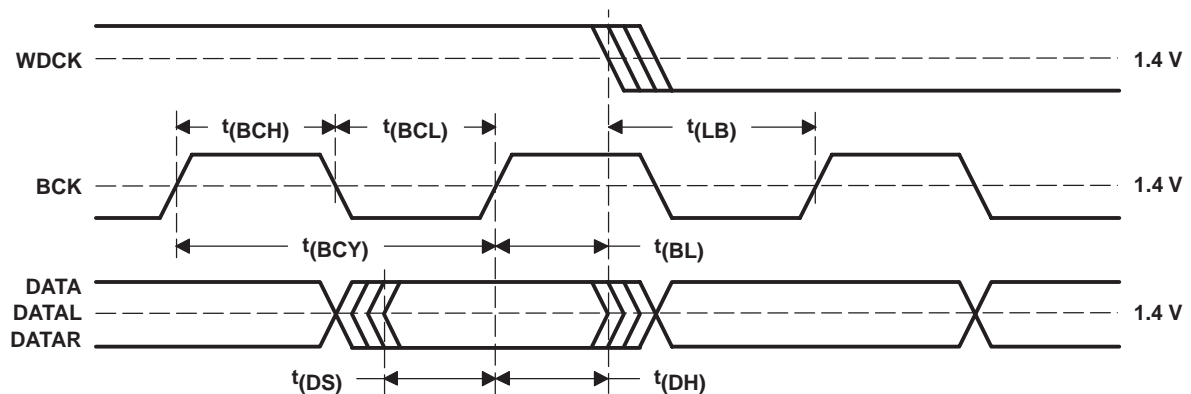

Figure 40. Audio Data Input Format for External Digital Filter (Internal DF Bypass Mode) Application

## System Clock (SCK) and Interface Timing

The PCM1796 in an application using an external digital filter requires the synchronization of WDCK and the system clock. The system clock is phase-free with respect to WDCK. Interface timing among WDCK, BCK, DATA, DATAL, and DATAR is shown in Figure 41.



PARAMETER	MIN	MAX	UNITS
t(BCY) BCK pulse cycle time	20		ns
t(BCL) BCK pulse duration, LOW	7		ns
t(BCH) BCK pulse duration, HIGH	7		ns
t(BL) BCK rising edge to WDCK falling edge	5		ns
t(LB) WDCK falling edge to BCK rising edge	5		ns
t(DS) DATA, DATAL, DATAR setup time	5		ns
t(DH) DATA, DATAL, DATAR hold time	5		ns

Figure 41. Audio Interface Timing for External Digital Filter (Internal DF Bypass Mode) Application

## FUNCTIONS AVAILABLE IN THE EXTERNAL DIGITAL FILTER MODE

The external digital filter mode is selected by setting DSD = 0 (register 20, B5) and DFTH = 1 (register 20, B4).

The external digital filter mode allows access to the majority of the PCM1796 mode control functions.

The following table shows the register mapping available when the external digital filter mode is selected, along with descriptions of functions which are modified when using this mode selection.

	B15	B14	B13	B12	B11	B10	B9	B8	B7	B6	B5	B4	B3	B2	B1	B0
Register 16	R/W	0	0	1	0	0	0	0	–	–	–	–	–	–	–	–
Register 17	R/W	0	0	1	0	0	0	1	–	–	–	–	–	–	–	–
Register 18	R/W	0	0	1	0	0	1	0	–	FMT2	FMT1	FMT0	–	–	–	–
Register 19	R/W	0	0	1	0	0	1	1	REV	–	–	OPE	–	DFMS	–	INZD
Register 20	R/W	0	0	1	0	1	0	0	–	SRST	0	1	MONO	CHSL	OS1	OS0
Register 21	R/W	0	0	1	0	1	0	1	–	–	–	–	–	–	–	PCMZ
Register 22	R	0	0	1	0	1	1	0	–	–	–	–	–	–	ZFGR	ZFGL

NOTE: –: Function is disabled. No operation even if data bit is set

### FMT[2:0]: Audio Data Format Selection

Default value: 000

FMT[2:0]	Audio Data Format Select
000	16-bit right-justified format (default)
001	20-bit right-justified format
010	24-bit right-justified format
Other	N/A

### OS[1:0]: Delta-Sigma Modulator Oversampling Rate Selection

Default value: 00

OS[1:0]	Operation Speed Select
00	8 times WDCK (default)
01	4 times WDCK
10	16 times WDCK
11	Reserved

The effective oversampling rate is determined by the oversampling performed by both the external digital filter and the delta-sigma modulator. For example, if the external digital filter is 8× oversampling, and the user selects OS[1:0] = 00, then the delta-sigma modulator oversamples by 8×, resulting in an effective oversampling rate of 64×. The 16× WDCK oversampling rate is not available above a 100-kHz sampling rate. If the oversampling rate selected is 16× WDCK, the system clock frequency must be over 256 f<sub>S</sub>.



**APPLICATION FOR DSD FORMAT (DSD MODE) INTERFACE**

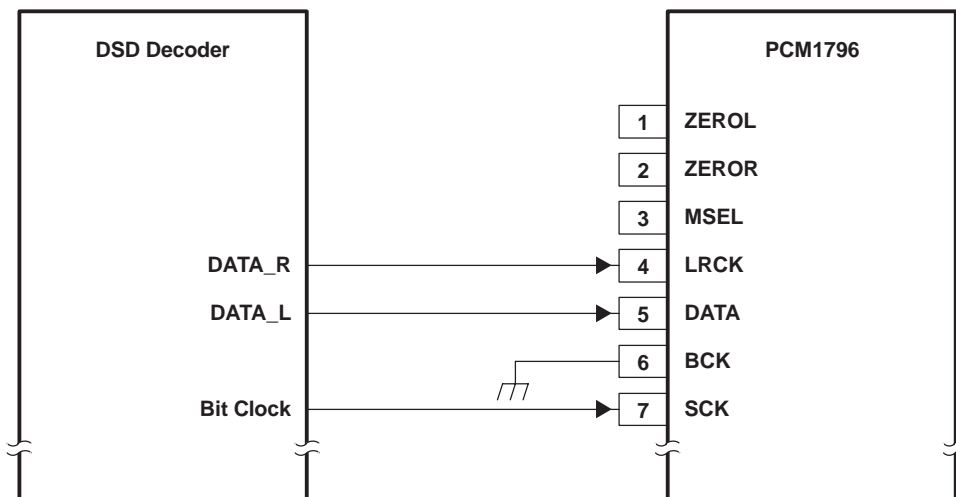

**Figure 42. Connection Diagram in DSD Mode**

**Feature**

This mode is used for interfacing directly to a DSD decoder, which is found in Super Audio CD™ (SACD) applications. The DSD mode is accessed by programming the following bit in the corresponding control register.

DSD = 1 (register 20)

The DSD mode provides a low-pass filtering function. The filtering is provided using an analog FIR filter structure. Four FIR responses are available, and are selected by the DMF[1:0] bits of control register 18.

The DSD bit must be set before inputting DSD data; otherwise, the PCM1796 erroneously detects the TDMCA mode, and commands are not accepted through the serial control interface.

**Pin Assignment When Using DSD Format Interface**

Several pins are redefined for DSD mode operation. These include:

- DATA (pin 5): DSDL as L-channel DSD data input
- LRCK (pin 4): DSDR as R-channel DSD data input
- SCK (pin 7): DBCK as bit clock for DSD data
- BCK (pin 6): Set LOW (N/A)

**Requirements for System Clock**

For operation in the DSD mode, the bit clock (DBCK) is required on pin 7 of the PCM1796. The frequency of the bit clock can be N times the sampling frequency. Generally, N is 64 in DSD applications.

The interface timing between the bit clock and DSDL and DSDR is required to meet the setup and hold time specifications shown in Figure 44.

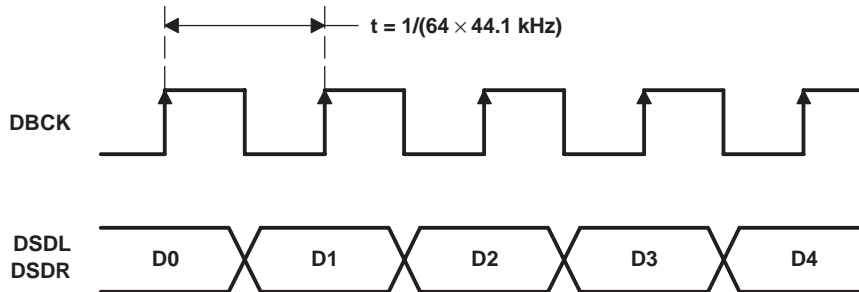

**Figure 43. Normal Data Output Form From DSD Decoder**

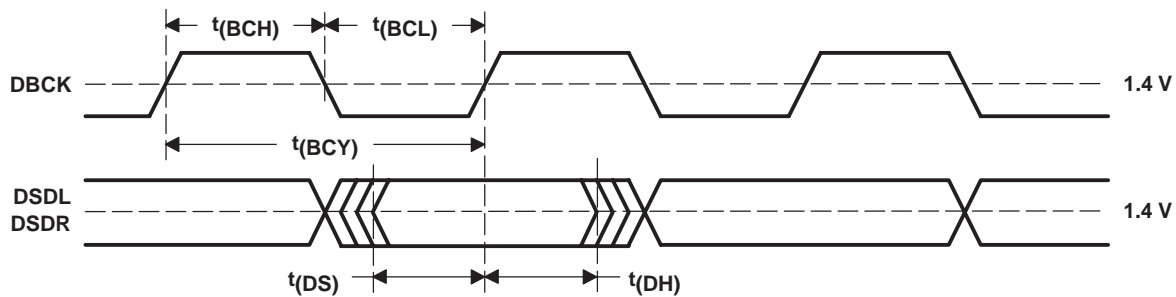

PARAMETER	MIN	MAX	UNITS
t(BCY) DBCK pulse cycle time	85 <sup>(1)</sup>		ns
t(BCH) DBCK high-level time	30		ns
t(BCL) DBCK low-level time	30		ns
t(DS) DSDL, DSDR setup time	10		ns
t(DH) DSDL, DSDR hold time	10		ns

<sup>(1)</sup> 2.8224 MHz × 4. (2.8224 MHz = 64 × 44.1 kHz. This value is specified as a sampling rate of DSD.)

**Figure 44. Timing for DSD Audio Interface**

**ANALOG FIR FILTER PERFORMANCE IN DSD MODE**

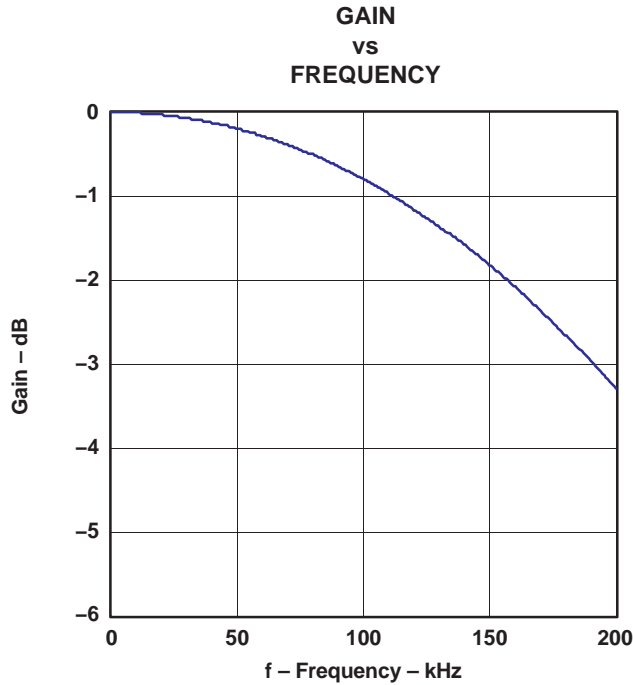

**Figure 45. DSD Filter-1, Low BW**

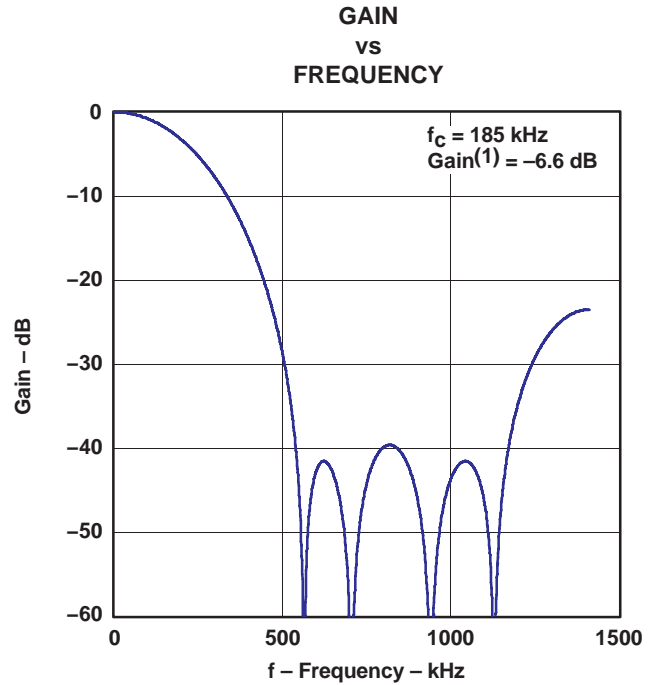

**Figure 46. DSD Filter-1, High BW**

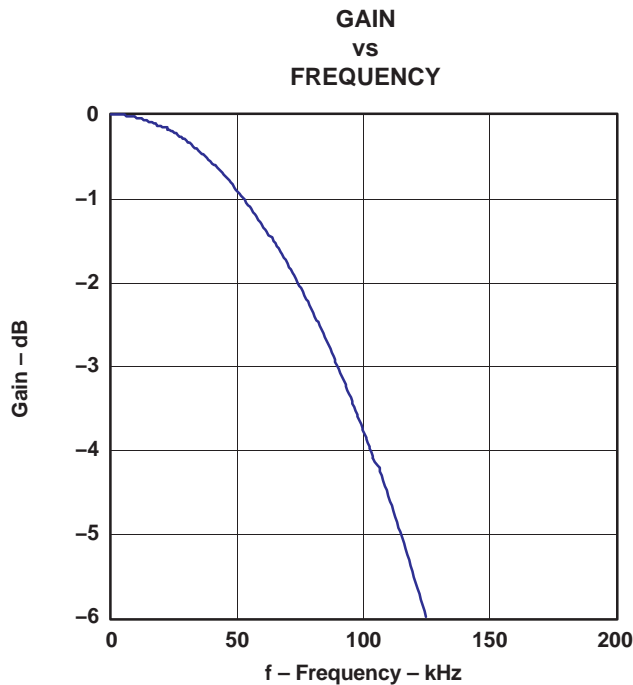

**Figure 47. DSD Filter-2, Low BW**

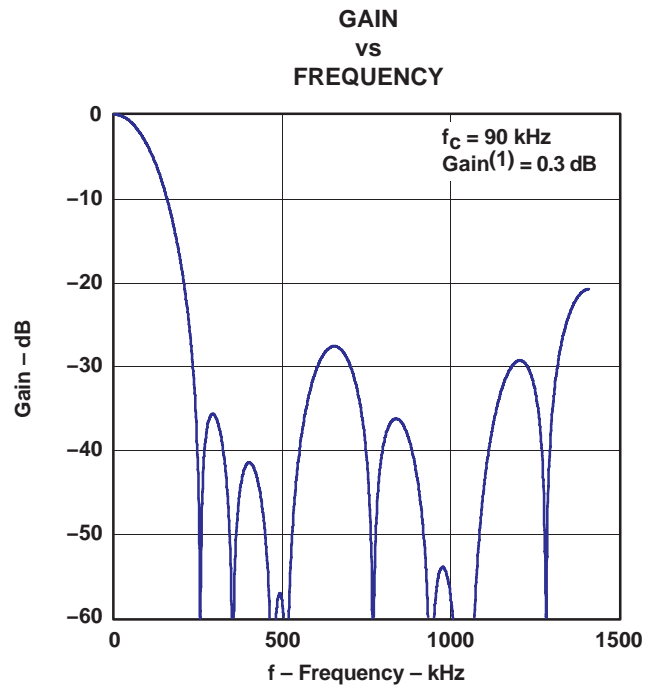

**Figure 48. DSD Filter-2, High BW**

(1) This gain is in comparison to PCM 0 dB, when the DSD input signal efficiency is 50%.

**ANALOG FIR FILTER PERFORMANCE IN DSD MODE (CONTINUED)**

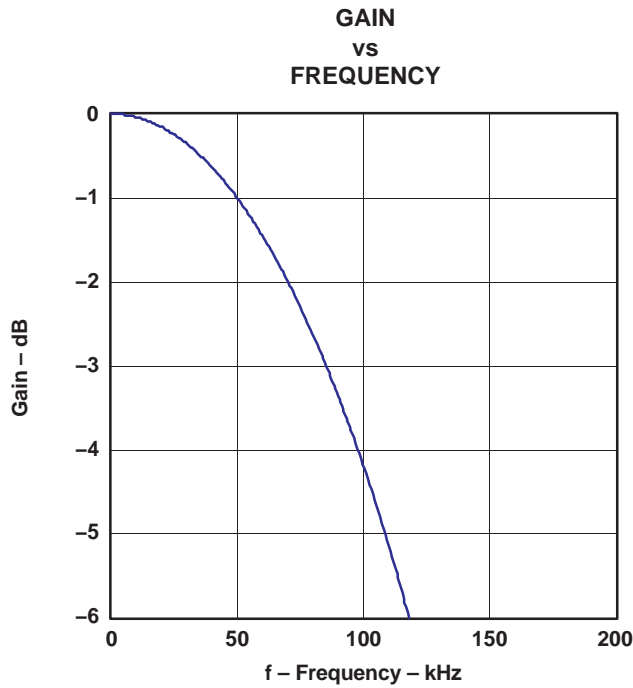

**Figure 49. DSD Filter-3, Low BW**

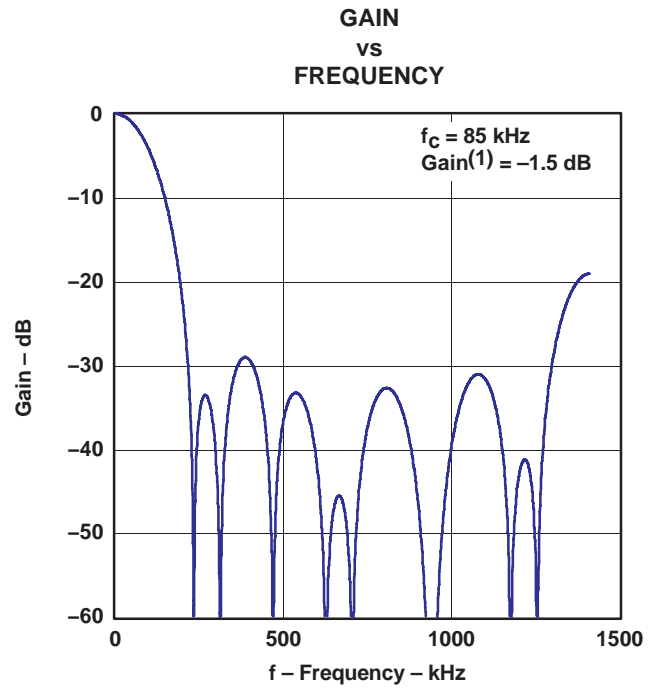

**Figure 50. DSD Filter-3, High BW**

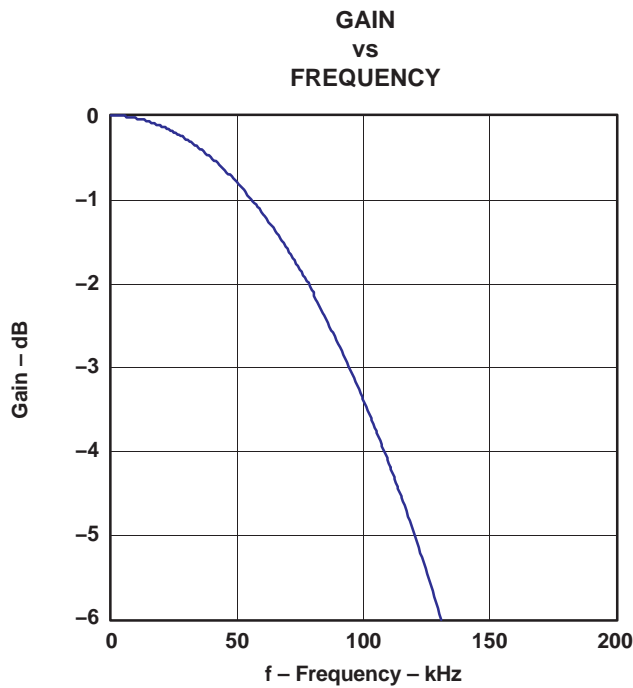

**Figure 51. DSD Filter-4, Low BW**

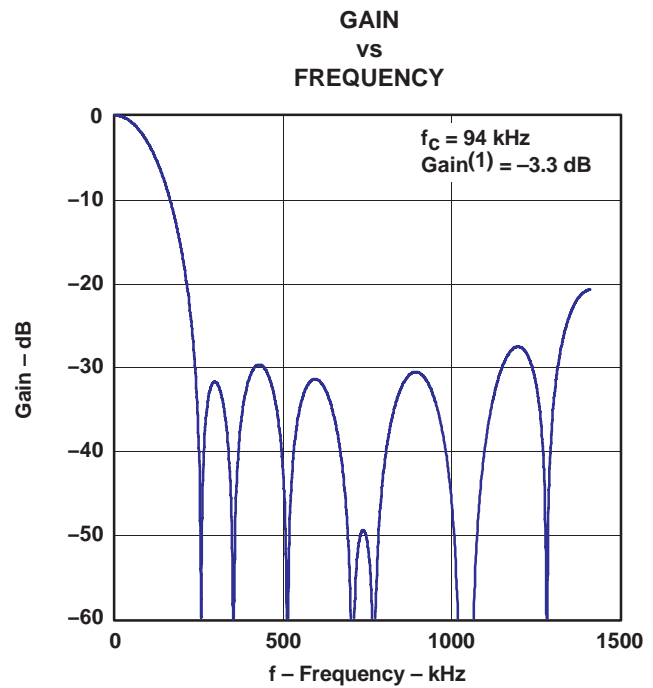

**Figure 52. DSD Filter-4, High BW**

(1) This gain is in comparison to PCM 0 dB, when the DSD input signal efficiency is 50%.

## DSD MODE CONFIGURATION AND FUNCTION CONTROLS

### Configuration for the DSD Interface Mode

The DSD interface mode is selected by setting DSD = 1 (register 20, B5).

	B15	B14	B13	B12	B11	B10	B9	B8	B7	B6	B5	B4	B3	B2	B1	B0
<b>Register 16</b>	R/W	0	0	1	0	0	0	0	–	–	–	–	–	–	–	–
<b>Register 17</b>	R/W	0	0	1	0	0	0	1	–	–	–	–	–	–	–	–
<b>Register 18</b>	R/W	0	0	1	0	0	1	0	–	–	–	–	DMF1	DMF0	–	–
<b>Register 19</b>	R/W	0	0	1	0	0	1	1	REV	–	–	OPE	–	–	–	–
<b>Register 20</b>	R/W	0	0	1	0	1	0	0	–	SRST	1	–	MONO	CHSL	OS1	OS0
<b>Register 21</b>	R	0	0	1	0	1	0	1	–	–	–	–	–	DZ1	DZ0	–
<b>Register 22</b>	R	0	0	1	0	1	1	0	–	–	–	–	–	–	ZFGR	ZFGL

NOTE: –: Function is disabled. No operation even if data bit is set

### DMF[1:0]: Analog-FIR Performance Selection

Default value: 00

DMF[1:0]	Analog-FIR Performance Select
00	FIR-1 (default)
01	FIR-2
10	FIR-3
11	FIR-4

Plots for the four analog FIR filter responses are shown in the *ANALOG FIR FILTER PERFORMANCE IN DSD MODE* section of this data sheet.

### OS[1:0]: Analog-FIR Operation-Speed Selection

Default value: 00

OS[1:0]	Operation-Speed Select
00	$f_{DBCK}$ (default)
01	$f_{DBCK}/2$
10	Reserved
11	$f_{DBCK}/4$

The OS bit in the DSD mode is used to select the operating rate of the analog FIR. The OS bits must be set before setting the DSD bit to 1.

## TDMCA INTERFACE FORMAT

The PCM1796 supports the time-division-multiplexed command and audio (TDMCA) data format to simplify the host control serial interface. The TDMCA format is designed not only for the McBSP of TI DSPs but also for any programmable devices. The TDMCA format can transfer not only audio data but also command data, so that it can be used together with any kind of device that supports the TDMCA format. The TDMCA frame consists of a command field, extended command field, and some audio data fields. Those audio data are transported to IN devices (such as a DAC) and/or from OUT devices (such as an ADC). The PCM1796 is an IN device. LRCK and BCK are used with both IN and OUT devices so that the sample frequency of all devices in a system must be the same. The TDMCA mode supports a maximum of 30 device IDs. The maximum number of audio channels depends on the BCK frequency.

### TDMCA Mode Determination

The PCM1796 recognizes the TDMCA mode automatically when it receives an LRCK signal with a pulse duration of two BCK clocks. If the TDMCA mode operation is not needed, the duty cycle of LRCK must be 50%. Figure 53 shows the LRCK and BCK timing that determines the TDMCA mode. The PCM1796 enters the TDMCA mode after two continuous TDMCA frames. Any TDMCA commands can be issued during the next TDMCA frame after the TDMCA mode is entered.

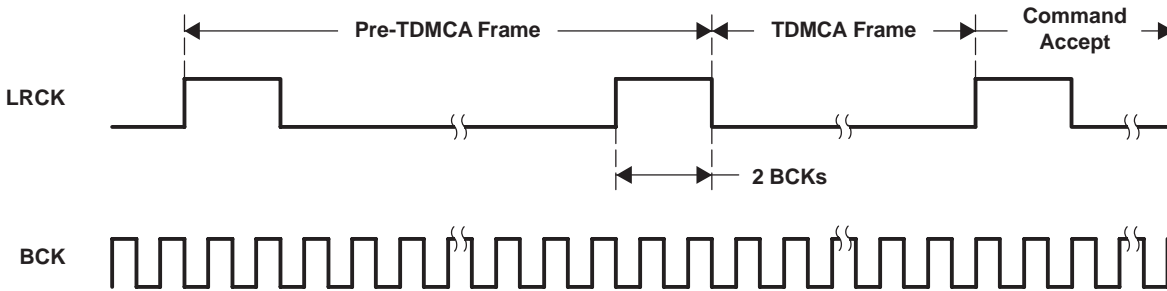

Figure 53. LRCK and BCK Timing for Determination of TDMCA Mode

### TDMCA Terminals

TDMCA requires six signals, of which four signals are for command and audio data interface, and one pair for daisy chaining. Those signals can be shared as in the following table. The DO signal has a 3-state output so that it can be connected directly to other devices.

TERMINAL NAME	TDMCA NAME	PROPERTY	DESCRIPTION
LRCK	LRCK	input	TDMCA frame start signal. It must be the same as the sampling frequency.
BCK	BCK	input	TDMCA clock. Its frequency must be high enough to communicate a TDMCA frame within an LRCK cycle.
DATA	DI	input	TDMCA command and audio data input signal
MDO	DO	output	TDMCA command data 3-state output signal
MC	DCI	input	TDMCA daisy-chain input signal
$\overline{MS}$	DCO	output	TDMCA daisy-chain output signal

### Device ID Determination

The TDMCA mode also supports a multichip implementation in one system. This means a host controller (DSP) can simultaneously support several TDMCA devices, which can be of the same type or different types, including PCM devices. The PCM devices are categorized as IN device, OUT device, IN/OUT device, and NO device. The IN device has an input port to receive audio data, the OUT device has an output port to supply audio data, the IN/OUT device has both input and output ports for audio data, and the NO device has no port for audio data but needs command data from the host. A DAC is an IN device, an ADC is an OUT device, a codec is an IN/OUT device, and a PLL is a NO device. The PCM1796 is an IN device. For the host controller to distinguish the devices, each device is assigned its own device ID by the daisy chain. The devices obtain their own device IDs automatically by connecting their DCI to the DCO of the preceding device and their DCO to the DCI of the following device in the daisy chain. The daisy chains are categorized as the IN chain and the OUT chain, which are completely independent and equivalent. Figure 54 shows an example daisy chain connection. If a system needs to chain the PCM1796 and a NO device in the same IN or OUT chain, the NO device must be chained at the back end of the chain because it does not require any audio data. Figure 55 shows an example of TDMCA system including an IN chain and an OUT chain with a TI DSP. For a device to get its own device ID, the DID signal must be set to 1 (see the *Command Field* section for details), and LRCK and BCK must be driven in the TDMCA mode for all PCM devices that are chained. The device at the top of the chain knows its device ID is 1 because its DCI is fixed HIGH. Other devices count the BCK pulses and observe their own DCI signal to determine their position and ID. Figure 56 shows the initialization of each device ID.

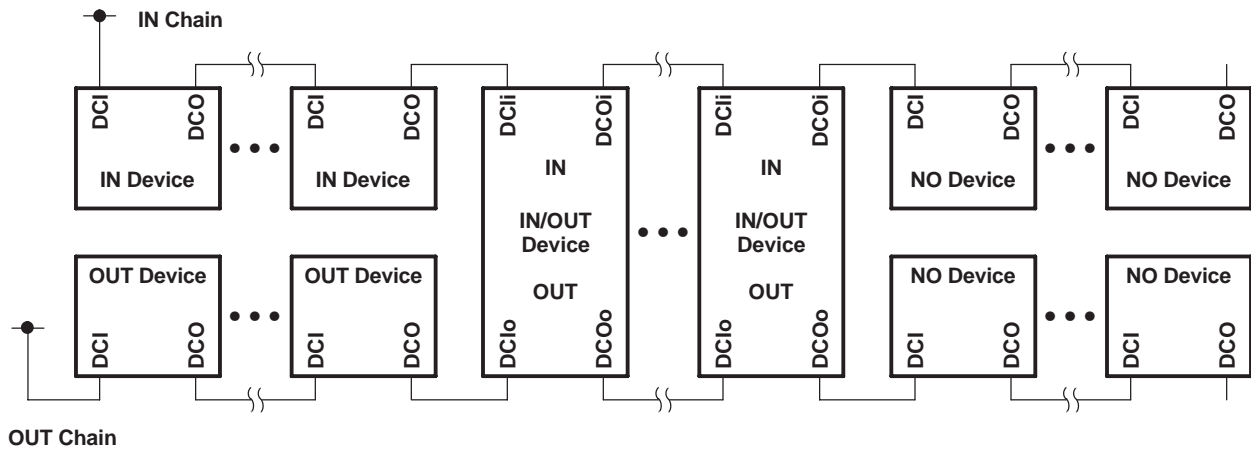

**Figure 54. Daisy Chain Connection**

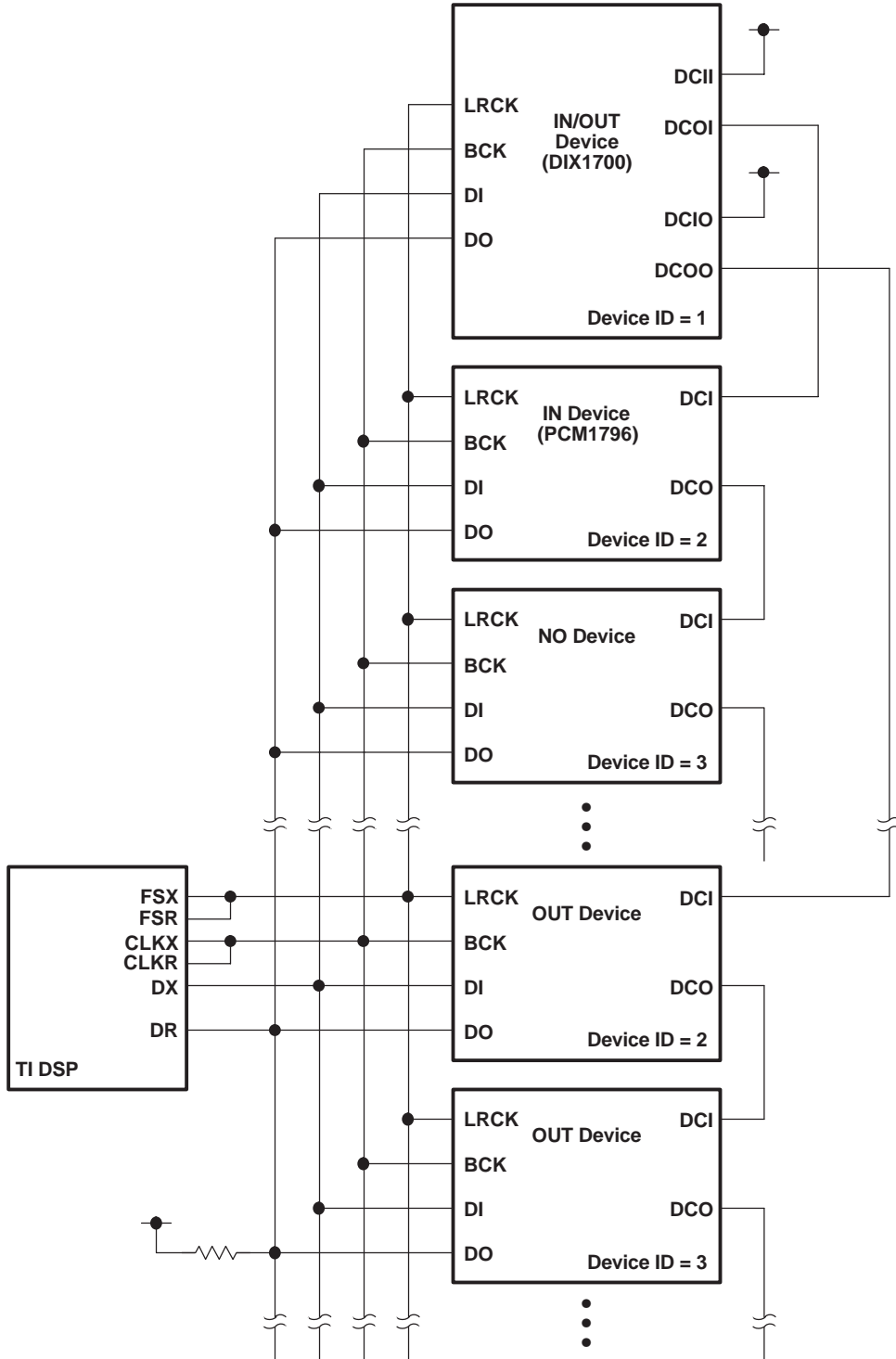

Figure 55. IN Daisy Chain and OUT Daisy Chain Connection for a Multichip System



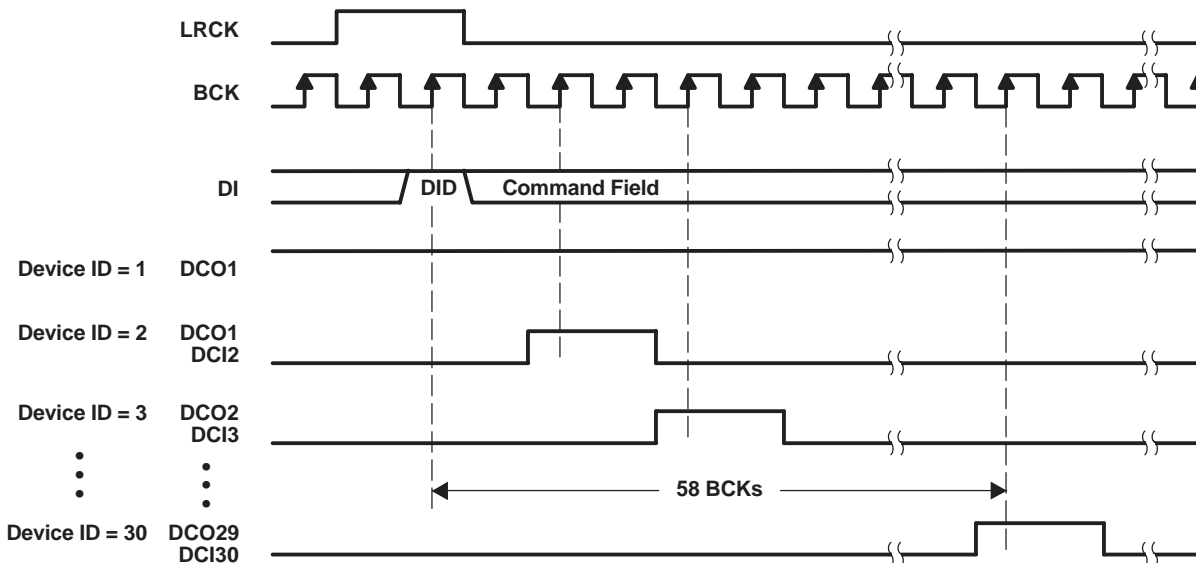

Figure 56. Device ID Determination Sequence

### TDMCA Frame

In general, the TDMCA frame consists of the command field, extended command (EMD) field, and audio data fields. All of them are 32 bits in length, but the lowest byte has no meaning. The MSB is transferred first for each field. The command field is always transferred as the first packet of the frame. The EMD field is transferred if the EMD flag of the command field is HIGH. If any EMD packets are transferred, no audio data follows the EMD packets. This frame is for quick system initialization. All devices of a daisy chain should respond to the command field and extended command field. The PCM1796 has two audio channels that can be selected by OPE (register 19). If the OPE bit is not set to HIGH, those audio channels are transferred. Figure 57 shows the general TDMCA frame. If some DACs are enabled, but corresponding audio data packets are not transferred, the analog outputs are unpredictable.



Figure 57. General TDMCA Frame

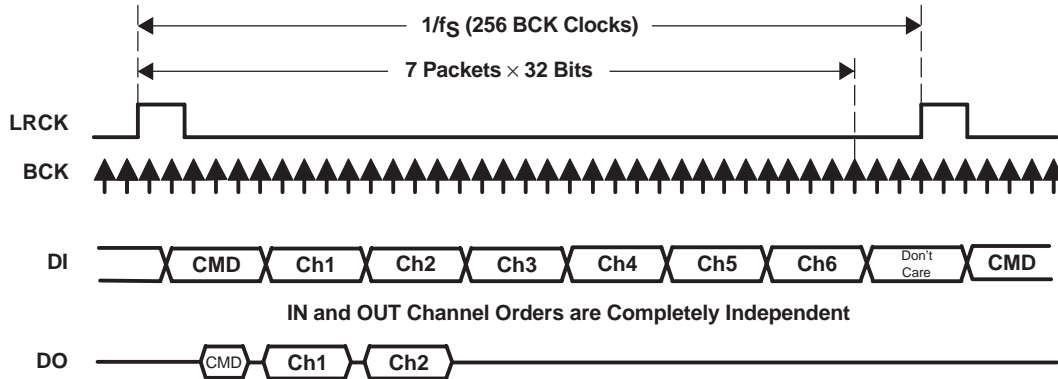

Figure 58. TDMCA Frame Example of 6-Ch DAC and 2-Ch ADC With Command Read

**Command Field**

The normal command field is defined as follows. When the DID bit (MSB) is 1, this frame is used only for device ID determination, and all remaining bits in the field are ignored.

	31	30	29	28	24	23	22	16	15	8	7	0
command	DID	EMD	DCS	device ID	R/W	register ID	data	not used				

**Bit 31: Device ID enable flag**

The PCM1796 operates to get its own device ID for TDMCA initialization if this bit is HIGH.

**Bit 30: Extended command enable flag**

The EMD packet is transferred if this bit is HIGH, otherwise skipped. Once this bit is HIGH, this frame does not contain any audio data. This is for system initialization.

**Bit 29: Daisy chain selection flag**

HIGH designates OUT-chain devices, LOW designates IN-chain devices. The PCM1796 is an IN device, so the DCS bit must be set to LOW.

**Bits[28:24]: Device ID**

The device ID is 5 bits length, and it can be defined. These bits identify the order of a device in the IN or OUT daisy chain. The top of the daisy chain defines device ID 1 and successive devices are numbered 2, 3, 4, etc. All devices for which the DCI is fixed HIGH are also defined as ID 1. The maximum device ID is 30 each in the IN and OUT chains. If a device ID of 0x1F is used, all devices are selected as broadcast when in the write mode. If a device ID of 0x00 is used, no device is selected.

**Bit 23: Command Read/Write flag**

If this bit is HIGH, the command is a read operation.

**Bits[22:16]: Register ID**

It is 7 bits in length.

**Bits[15:8]: Command data**

It is 8 bits in length. Any valid data can be chosen for each register.

**Bits[7:0]: Not used**

These bits are never transported when a read operation is performed.

**Extended command field**

The extended command field is the same as the command field, except that it does not have a DID flag.

	31	30	29	28	24	23	22	16	15	8	7	0
extended command	rsvd	EMD	DCS	device ID	R/W	register ID	data	not used				

## Audio Fields

The audio field is 32 bits in length and the audio data is transferred MSB first, so the other fields must be stuffed with 0s as shown in the following example.

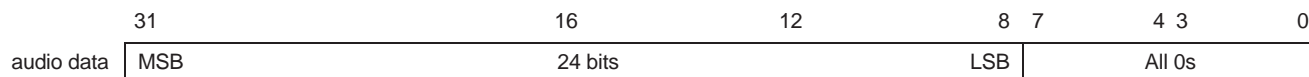

## TDMCA Register Requirements

TDMCA mode requires device ID and audio channel information, previously described. The OPE bit in register 19 indicates audio channel availability and register 23 indicates the device ID. Register 23 is used only in the TDMCA mode. See the mode control register map (Table 4).

## Register Write/Read Operation

The command supports register write and read operations. If the command requests to read one register, the read data is transferred on DO during the data phase of the timing cycle. The DI signal can be retrieved at the positive edge of BCK, and the DO signal is driven at the negative edge of BCK. DO is activated one BCK cycle early to compensate for the output delay caused by high impedance. Figure 59 shows the TDMCA write and read timing.

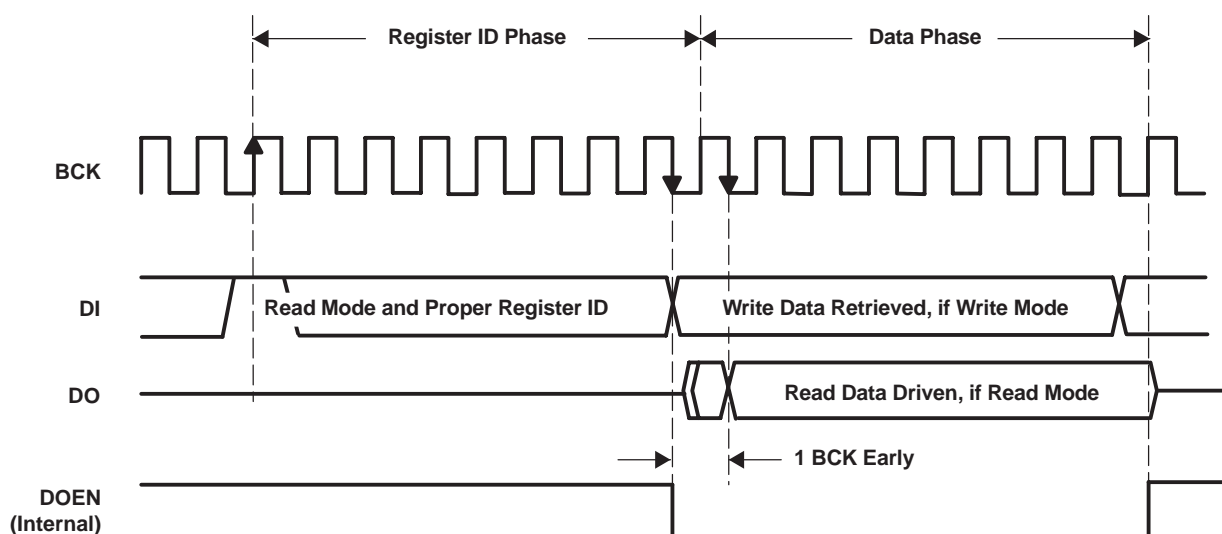

Figure 59. TDMCA Write and Read Operation Timing

## TDMCA-Mode Operation

DCO specifies the owner of the next audio channel in TDMCA-mode operation. When a device retrieves its own audio channel data, DCO goes HIGH during the last audio channel period. Figure 60 shows the DCO output timing in TDMCA-mode operation. The host controller ignores the behavior of DCI and DCO. DCO indicates the last audio channel of each device. Therefore, DCI means the next audio channel is allocated.

If some devices are skipped due to no active audio channel, the skipped devices must notify the next device that the DCO will be passed through the next DCI. Figure 61 and Figure 62 show DCO timing with skip operation. Figure 63 shows the ac timing of the daisy chain signals.

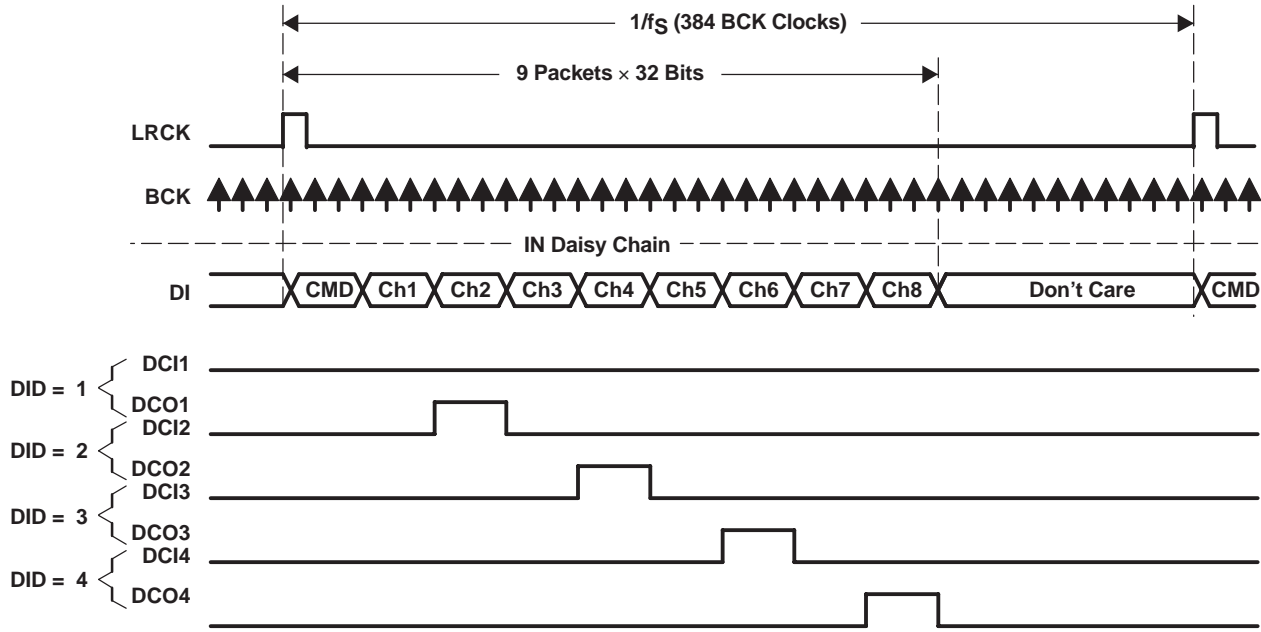

Figure 60. DCO Output Timing of TDMCA Mode Operation

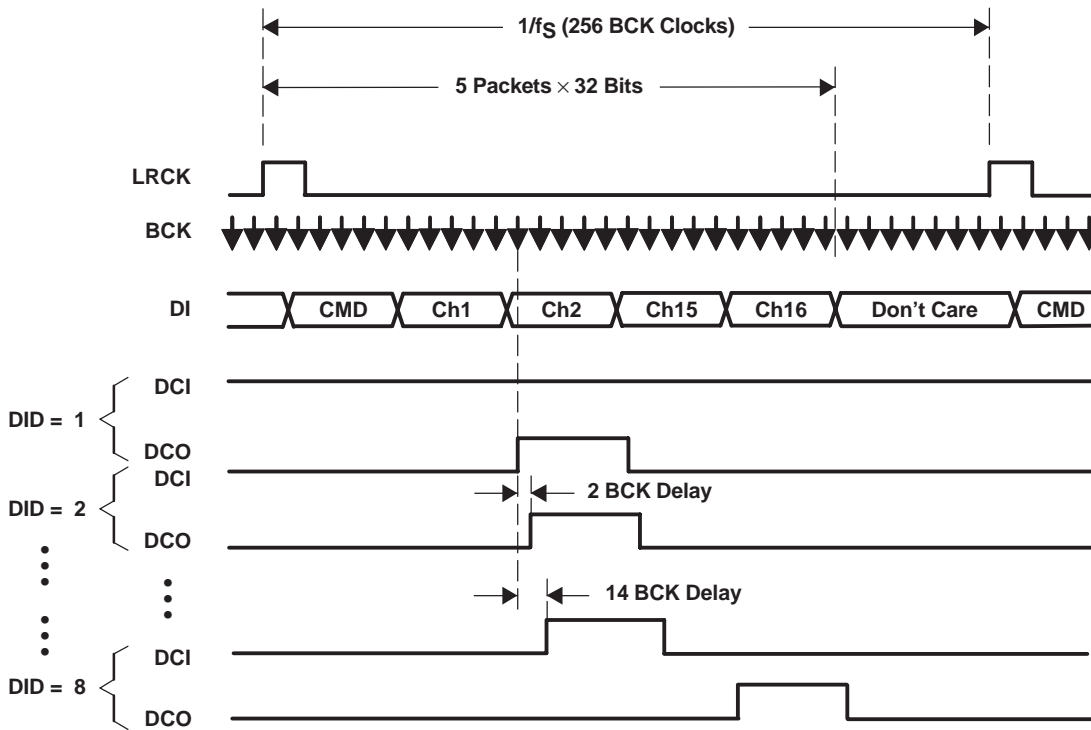

Figure 61. DCO Output Timing With Skip Operation

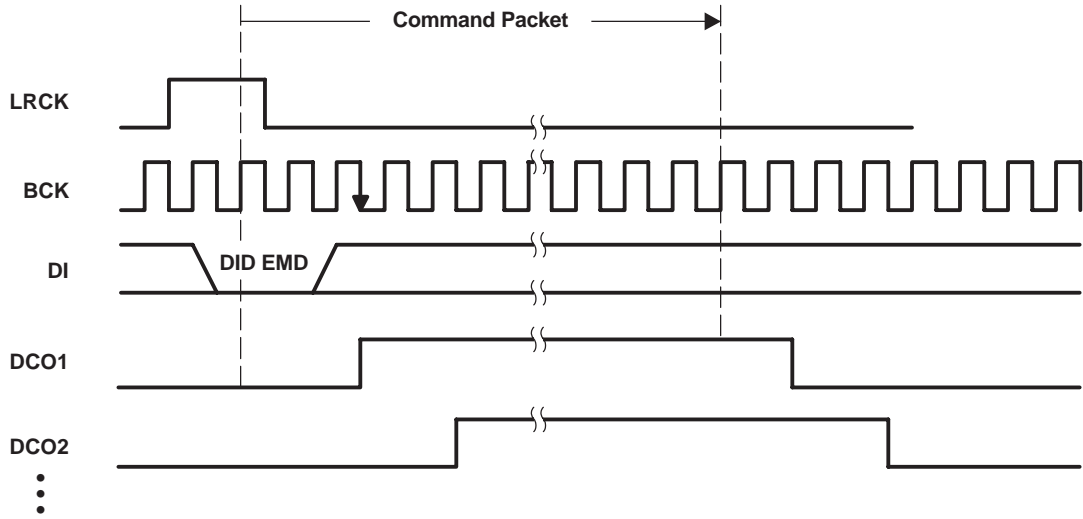
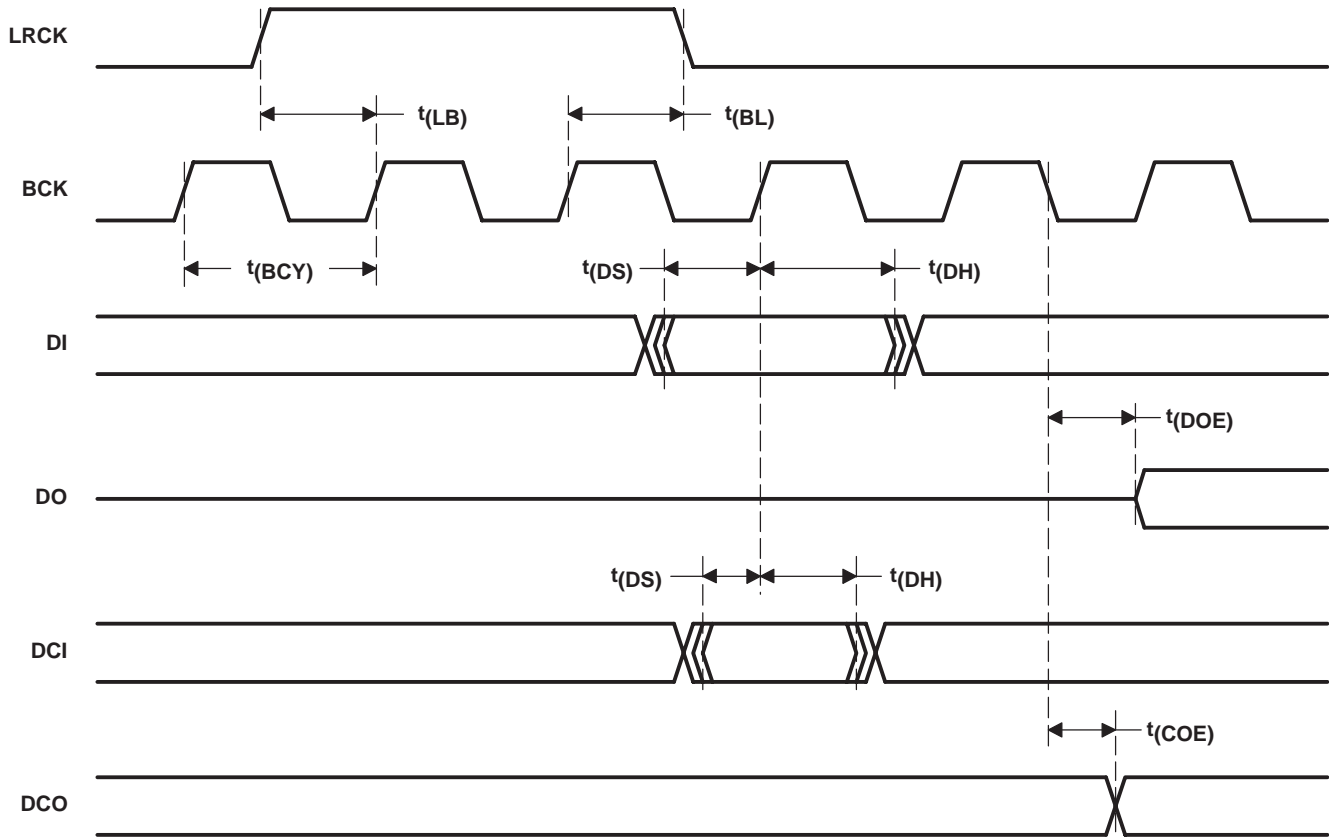

Figure 62. DCO Output Timing With Skip Operation (for Command Packet 1)



PARAMETER		MIN	MAX	UNITS
t(BCY)	BCK pulse cycle time	20		ns
t(LB)	LRCK setup time	0		ns
t(BL)	LRCK hold time	3		ns
t(DS)	DI setup time	0		ns
t(DH)	DI hold time	3		ns
t(DS)	DCI setup time	0		ns
t(DH)	DCI hold time	3		ns
t(DOE)	DO output delay <sup>(1)</sup>		8	ns
t(COE)	DCO output delay <sup>(1)</sup>		6	ns

<sup>(1)</sup> Load capacitance is 10 pF.

Figure 63. AC Timing of Daisy Chain Signals

## ANALOG OUTPUT

Table 5 and Figure 64 show the relationship between the digital input code and analog output.

**Table 5. Analog Output Current and Voltage**

	800000 (-FS)	000000 (BPZ)	7FFFFFFF (+FS)
I <sub>OUTN</sub> [mA]	-1.5	-3.5	-5.5
I <sub>OUTP</sub> [mA]	-5.5	-3.5	-1.5
V <sub>OUTN</sub> [V]	-1.23	-2.87	-4.51
V <sub>OUTP</sub> [V]	-4.51	-2.87	-1.23
V <sub>OUT</sub> [V]	-2.98	0	2.98

NOTE: V<sub>OUTN</sub> is the output of U1, V<sub>OUTP</sub> is the output of U2, and V<sub>OUT</sub> is the output of U3 in the measurement circuit of Figure 36.

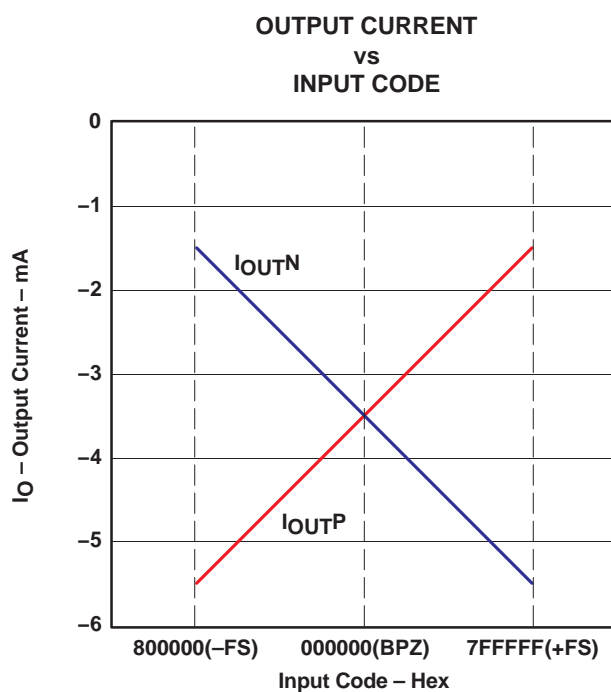

**Figure 64. The Relationship Between Digital Input and Analog Output**

**PACKAGING INFORMATION**

Orderable Device	Status (1)	Package Type	Package Drawing	Pins	Package Qty	Eco Plan (2)	Lead finish/ Ball material (6)	MSL Peak Temp (3)	Op Temp (°C)	Device Marking (4/5)	Samples
PCM1796DB	ACTIVE	SSOP	DB	28	47	RoHS & Green	Call TI   NIPDAU	Level-1-260C-UNLIM	-25 to 85	PCM1796	<a href="#">Samples</a>
PCM1796DBR	ACTIVE	SSOP	DB	28	2000	RoHS & Green	NIPDAU	Level-1-260C-UNLIM	-25 to 85	PCM1796	<a href="#">Samples</a>

(1) The marketing status values are defined as follows:

**ACTIVE:** Product device recommended for new designs.

**LIFEBUY:** TI has announced that the device will be discontinued, and a lifetime-buy period is in effect.

**NRND:** Not recommended for new designs. Device is in production to support existing customers, but TI does not recommend using this part in a new design.

**PREVIEW:** Device has been announced but is not in production. Samples may or may not be available.

**OBSOLETE:** TI has discontinued the production of the device.

(2) **RoHS:** TI defines "RoHS" to mean semiconductor products that are compliant with the current EU RoHS requirements for all 10 RoHS substances, including the requirement that RoHS substance do not exceed 0.1% by weight in homogeneous materials. Where designed to be soldered at high temperatures, "RoHS" products are suitable for use in specified lead-free processes. TI may reference these types of products as "Pb-Free".

**RoHS Exempt:** TI defines "RoHS Exempt" to mean products that contain lead but are compliant with EU RoHS pursuant to a specific EU RoHS exemption.

**Green:** TI defines "Green" to mean the content of Chlorine (Cl) and Bromine (Br) based flame retardants meet JS709B low halogen requirements of <=1000ppm threshold. Antimony trioxide based flame retardants must also meet the <=1000ppm threshold requirement.

(3) MSL, Peak Temp. - The Moisture Sensitivity Level rating according to the JEDEC industry standard classifications, and peak solder temperature.

(4) There may be additional marking, which relates to the logo, the lot trace code information, or the environmental category on the device.

(5) Multiple Device Markings will be inside parentheses. Only one Device Marking contained in parentheses and separated by a "~" will appear on a device. If a line is indented then it is a continuation of the previous line and the two combined represent the entire Device Marking for that device.

(6) Lead finish/Ball material - Orderable Devices may have multiple material finish options. Finish options are separated by a vertical ruled line. Lead finish/Ball material values may wrap to two lines if the finish value exceeds the maximum column width.

**Important Information and Disclaimer:**The information provided on this page represents TI's knowledge and belief as of the date that it is provided. TI bases its knowledge and belief on information provided by third parties, and makes no representation or warranty as to the accuracy of such information. Efforts are underway to better integrate information from third parties. TI has taken and continues to take reasonable steps to provide representative and accurate information but may not have conducted destructive testing or chemical analysis on incoming materials and chemicals. TI and TI suppliers consider certain information to be proprietary, and thus CAS numbers and other limited information may not be available for release.

In no event shall TI's liability arising out of such information exceed the total purchase price of the TI part(s) at issue in this document sold by TI to Customer on an annual basis.





**TUBE**

\*All dimensions are nominal

Device	Package Name	Package Type	Pins	SPQ	L (mm)	W (mm)	T (μm)	B (mm)
PCM1796DB	DB	SSOP	28	47	530	10.5	4000	4.1
PCM1796DB	DB	SSOP	28	47	500	10.6	500	9.6
PCM1796DB	DB	SSOP	28	47	530	10.5	4000	4.1

# DB0028A



# PACKAGE OUTLINE

## SSOP - 2 mm max height

SMALL OUTLINE PACKAGE



4214853/B 03/2018

### NOTES:

1. All linear dimensions are in millimeters. Any dimensions in parenthesis are for reference only. Dimensioning and tolerancing per ASME Y14.5M.
2. This drawing is subject to change without notice.
3. This dimension does not include mold flash, protrusions, or gate burrs. Mold flash, protrusions, or gate burrs shall not exceed 0.15 mm per side.
4. This dimension does not include interlead flash. Interlead flash shall not exceed 0.25 mm per side.
5. Reference JEDEC registration MO-150.

# EXAMPLE BOARD LAYOUT

DB0028A

SSOP - 2 mm max height

SMALL OUTLINE PACKAGE

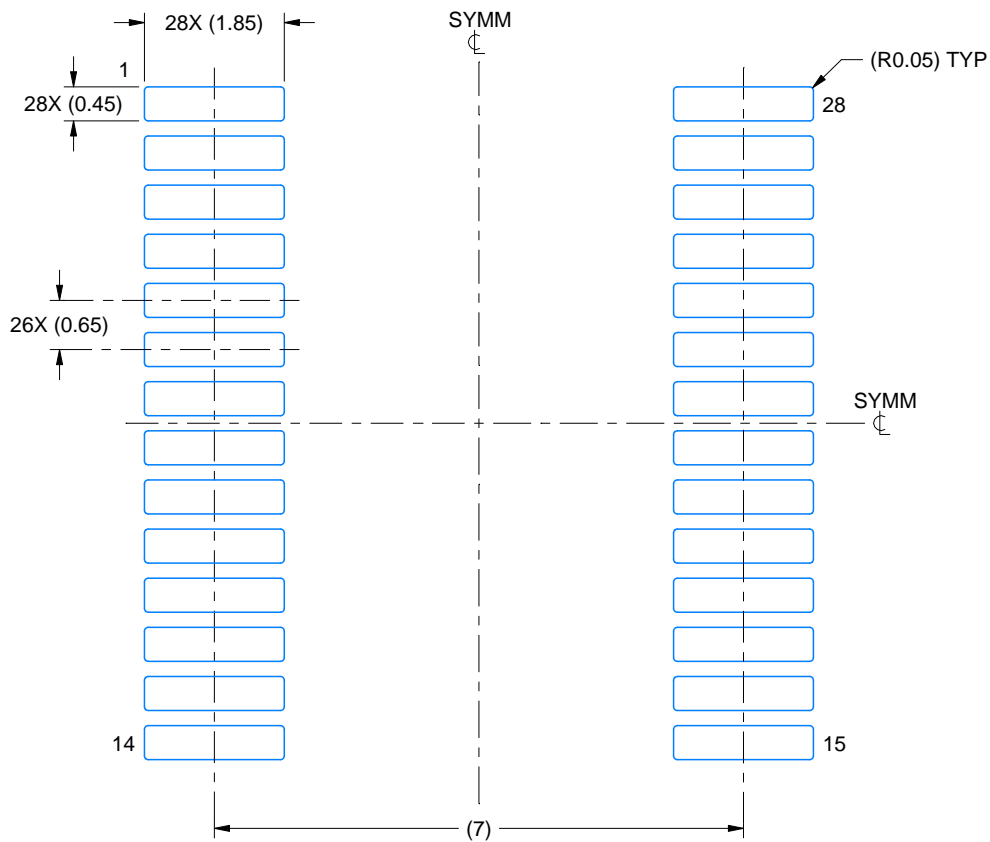

LAND PATTERN EXAMPLE  
EXPOSED METAL SHOWN  
SCALE: 10X



4214853/B 03/2018

NOTES: (continued)

- 6. Publication IPC-7351 may have alternate designs.
- 7. Solder mask tolerances between and around signal pads can vary based on board fabrication site.

# EXAMPLE STENCIL DESIGN

DB0028A

SSOP - 2 mm max height

SMALL OUTLINE PACKAGE



NOTES: (continued)

8. Laser cutting apertures with trapezoidal walls and rounded corners may offer better paste release. IPC-7525 may have alternate design recommendations.
9. Board assembly site may have different recommendations for stencil design.

## IMPORTANT NOTICE AND DISCLAIMER

TI PROVIDES TECHNICAL AND RELIABILITY DATA (INCLUDING DATA SHEETS), DESIGN RESOURCES (INCLUDING REFERENCE DESIGNS), APPLICATION OR OTHER DESIGN ADVICE, WEB TOOLS, SAFETY INFORMATION, AND OTHER RESOURCES "AS IS" AND WITH ALL FAULTS, AND DISCLAIMS ALL WARRANTIES, EXPRESS AND IMPLIED, INCLUDING WITHOUT LIMITATION ANY IMPLIED WARRANTIES OF MERCHANTABILITY, FITNESS FOR A PARTICULAR PURPOSE OR NON-INFRINGEMENT OF THIRD PARTY INTELLECTUAL PROPERTY RIGHTS.

These resources are intended for skilled developers designing with TI products. You are solely responsible for (1) selecting the appropriate TI products for your application, (2) designing, validating and testing your application, and (3) ensuring your application meets applicable standards, and any other safety, security, regulatory or other requirements.

These resources are subject to change without notice. TI grants you permission to use these resources only for development of an application that uses the TI products described in the resource. Other reproduction and display of these resources is prohibited. No license is granted to any other TI intellectual property right or to any third party intellectual property right. TI disclaims responsibility for, and you will fully indemnify TI and its representatives against, any claims, damages, costs, losses, and liabilities arising out of your use of these resources.

TI's products are provided subject to [TI's Terms of Sale](#) or other applicable terms available either on [ti.com](https://www.ti.com) or provided in conjunction with such TI products. TI's provision of these resources does not expand or otherwise alter TI's applicable warranties or warranty disclaimers for TI products.

TI objects to and rejects any additional or different terms you may have proposed.

Mailing Address: Texas Instruments, Post Office Box 655303, Dallas, Texas 75265  
Copyright © 2024, Texas Instruments Incorporated