

# A2L Refrigerant Standard Overview and TI Mitigation Control Board Designs for Designers



Brian Dempsey

## ABSTRACT

This technical article dives into the new A2L standards for residential and commercial HVAC systems and some of the system changes required to meet this standard. A2L refrigerants are refrigerants that have a lower global warming potential or GWP. This paper shares details of the mitigation tasks requirements for new A2L refrigerant HVAC systems as the A2I relate to the UL60335-2-40 standard, as well as give an overview of a basic mitigation board and other relevant content for designers.

## Table of Contents

<b>1 Introduction</b> .....	2
<b>2 Example Mitigation Control Board Design</b> .....	4
2.1 Overview of Mitigation Board Functions.....	7
2.2 Audible and Visible Detection Alarm.....	7
2.3 Freeze Detection (Water-Based Systems).....	8
2.4 Isolation and or Safety Shut-off Valves (SSOVs) in the Refrigeration System to Limit Releasable Charge.....	9
2.5 Electronic Controls With A2L Logic to Perform Required Actions in The Event of a Leak — Such as Shutting off the Compressor and or Other Components.....	10
2.6 Ventilation and or Circulation Fans Within Cases or Walk-in Units.....	11
<b>3 Summary</b> .....	14
<b>4 References</b> .....	14

## Trademarks

SimpleLink™ and LaunchPad™ are trademarks of Texas Instruments.  
All trademarks are the property of their respective owners.

## 1 Introduction

A2L refrigerants get the respective name from the ASHRAE safety classification and are mildly flammable, low toxicity, and low global warming potential, or GWP. These refrigerants also have a zero-ozone depletion potential, or ODP. As far as the chemical makeup of these refrigerants, A2L refrigerants are hydrofluoroolefins (HFO) or a blend of HFOs. Compared to previous HFC and HCFC refrigerants used in HVAC systems, namely R-410A and R-22 among others, the A2L refrigerants are more energy efficient while also conforming to greener energy initiatives worldwide. [Table 1-1](#) shows some common HVAC refrigerants along with the respective GWP/ODP values.

**Table 1-1. Common Refrigerants and GWP/ODP Values**

Refrigerant	Type	GWP	ODP
R-22	HCFC	1820	0.055
R-410A	HFC	2088	0
R-134A	HFC	1430	0
R-1234YF	HFO	4	0
R-1234ZE	HFO	6	0
R-32	HFC	675	0
R-454B	HFC	466	0

The drawback to A2L refrigerants is the inherent mild flammability associated with the chemical makeup, which means there are equipment manufacturer regulations needed to mitigate any dangerous situations where the refrigerant can combust given an ignition source. [Figure 1-1](#) shows a breakdown of different types of these refrigerants along with the respective ignition combustion data.

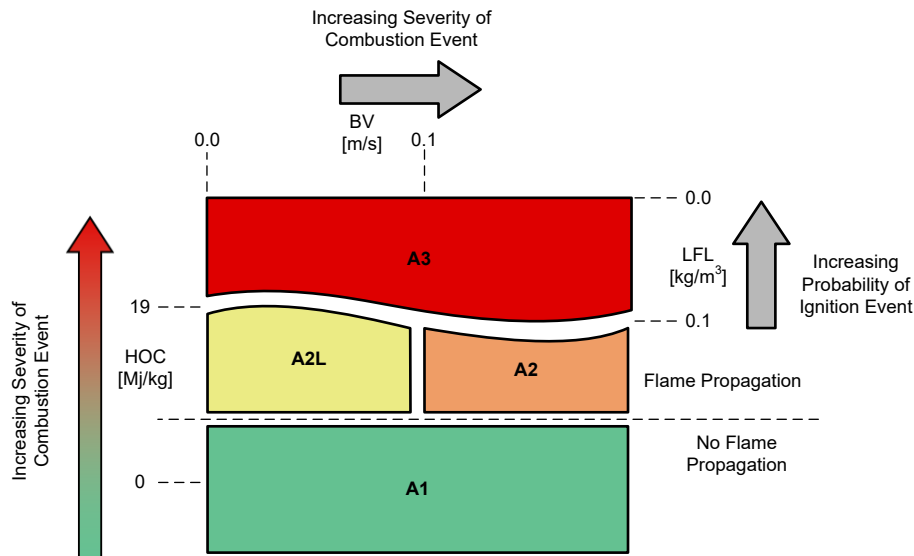

**Figure 1-1. HVAC Refrigerant Combustion and Propagation Diagram**

A2L-based systems and the additional required electronics to comply with UL 60335-2-40. To make sure safe operation, air conditioning equipment can feature special components, such as refrigerant detection systems (RDS), as per safety standard UL 60335-2-40. RDS detects specific refrigerants and, upon exceeding predefined thresholds, triggers mitigation actions like activating fans to dilute refrigerant concentration via the mitigation board. Requirements for the RDS include:

- The leaking gas shall not exceed 25% of the LFL,
- In addition to not exceeding 15% of the LFL for a period of 5 min after the RDS has reset.
- Refrigerant detection system shall make output within 30 seconds of direct exposure to 25% LFL

The deployment of RDS and adherence to safety standards are critical steps in the industry's response to regulatory changes. More information on the requirements of A2L sensor modules can be found in [A2L Refrigerant Adoption: Considerations and Requirements](#).

The second crucial component of this standard is the **mitigation board** which handles all of the required tasks once the refrigerant concentration threshold has been reached as described above. This includes:

- Switching off compressor unless the operation reduces the leak rate, or the total amount released into the indoor space
- Turning on the indoor blower fan
- Audible and visual indication that a refrigerant leak has been detected (or that the A2L sensor has malfunctioned and needs to be replaced)
- Freeze detection circuitry for water-based systems
- Fully opening zoning dampers (if applicable) to disperse the gas within the system
- Engaging any safety shut-off valves (if applicable)

## 2 Example Mitigation Control Board Design

Figure 2-1 shows an example implementation of a mitigation board for HVAC systems. The board interfaces to the sensor module and based on the detection of refrigerant, or lack thereof, the board can carry out mitigation actions as necessary. More information on the sensor module design considerations can be found in [A2L Refrigerant Adoption: Considerations and Requirements](#).

In some cases, the control signals from the *mitigation* control board are sent to the existing *furnace* control board to switch relays on or off for the compressor and the indoor blower fan. This can simplify the mitigation board design greatly and allow the preexisting furnace control board to execute the mitigation tasks.

This example design encompasses all of the mitigation tasks outlined in the ensuing section of this article to show a complete design that can be used for reference by the designer. The device selection is mainly driven by the lowest cost options available, allowing for a cost sensitive design that does not compromise the performance of executing the mitigation tasks.

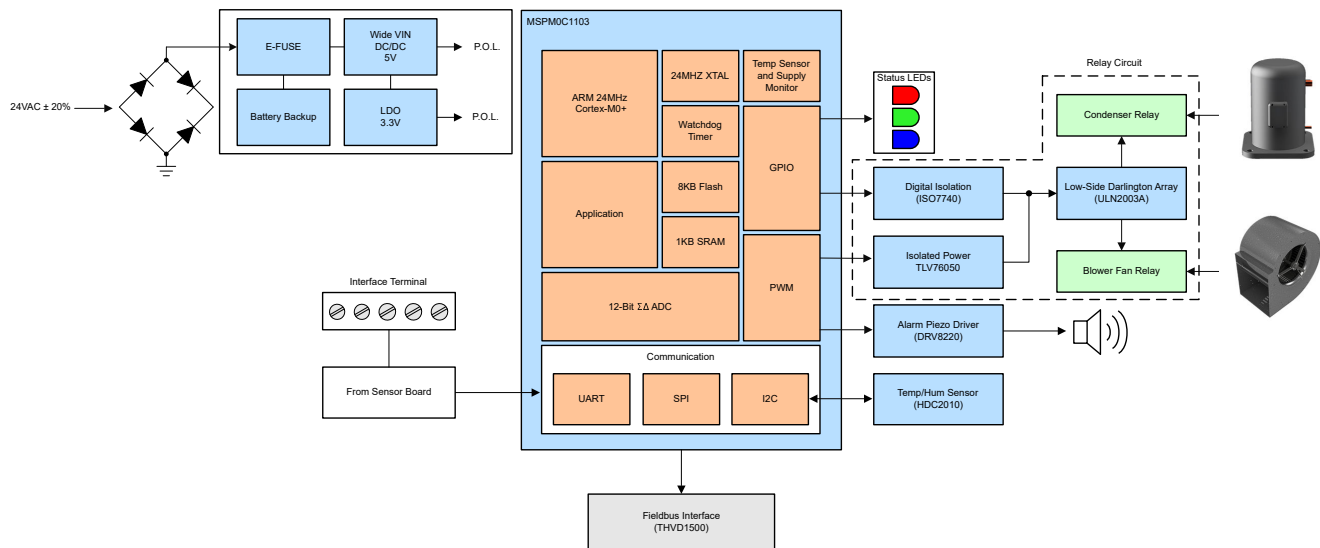

Figure 2-1. A2L Mitigation Control Board Block Diagram

### Device Selection

**MCU:** For the MCU, there is not a need for high performance so the lowest cost MSPM0 was chosen (Figure 2-2). This option provides the necessary peripherals for communicating with the sensor module and other fieldbus devices and also provides PWM and GPIO functionality for relays, the peizo driver, and the indication LEDs.

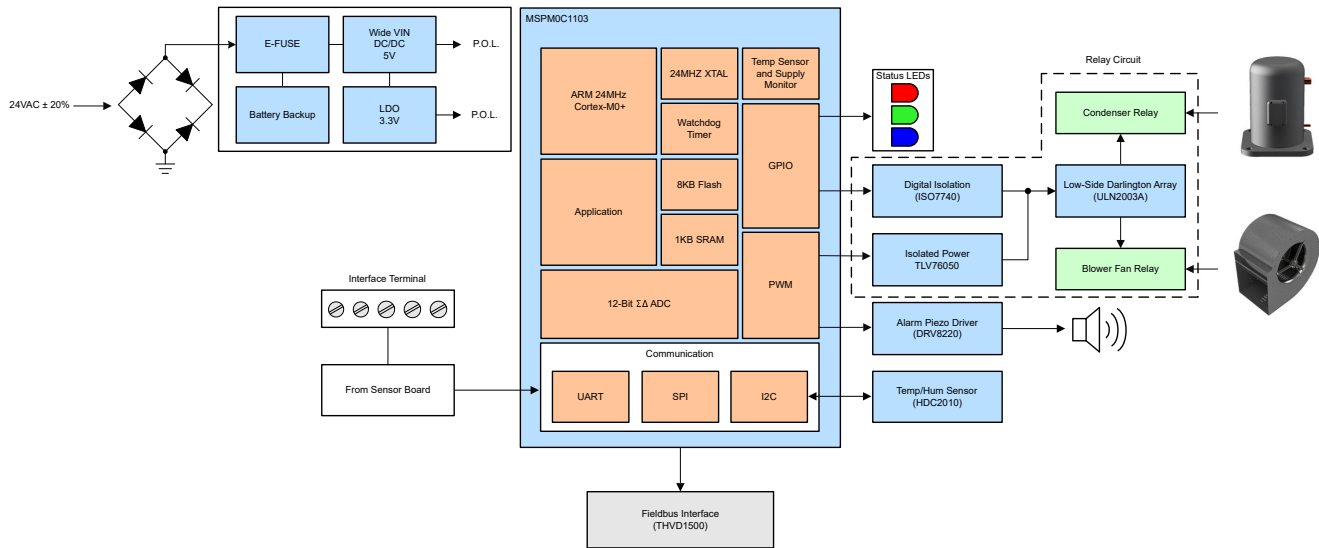

Figure 2-2. MSPM0C110 Functional Block Diagram

**Relay Control:** The relay control for the indoor blower fan and the compressor cutoff is comprised of several devices along with some discrete components as well.

- Figure 2-3 is used as an isolation barrier between the MCU and the field side relay control signal. This device is a 4-channel digital isolator which provides a low-cost design with robust protection features.

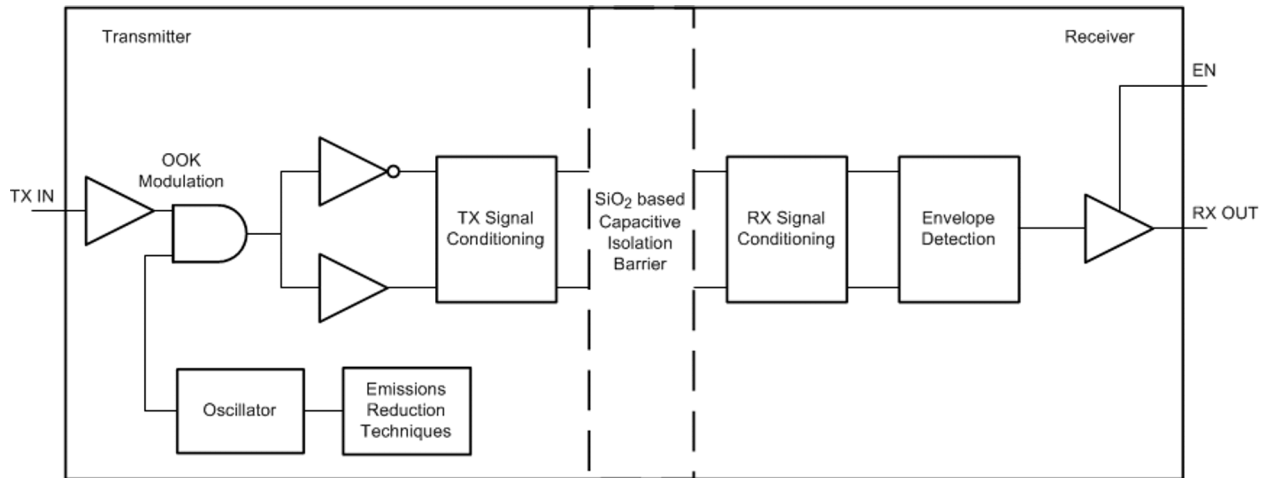

Figure 2-3. ISO7740 Functional Block Diagram

- Figure 2-4 consists of seven NPN Darlington pairs that feature high-voltage outputs with common-cathode clamp diodes for switching inductive loads. The collector-current rating of a single Darlington pair is 500mA. The Darlington pairs can be paralleled for higher current capability

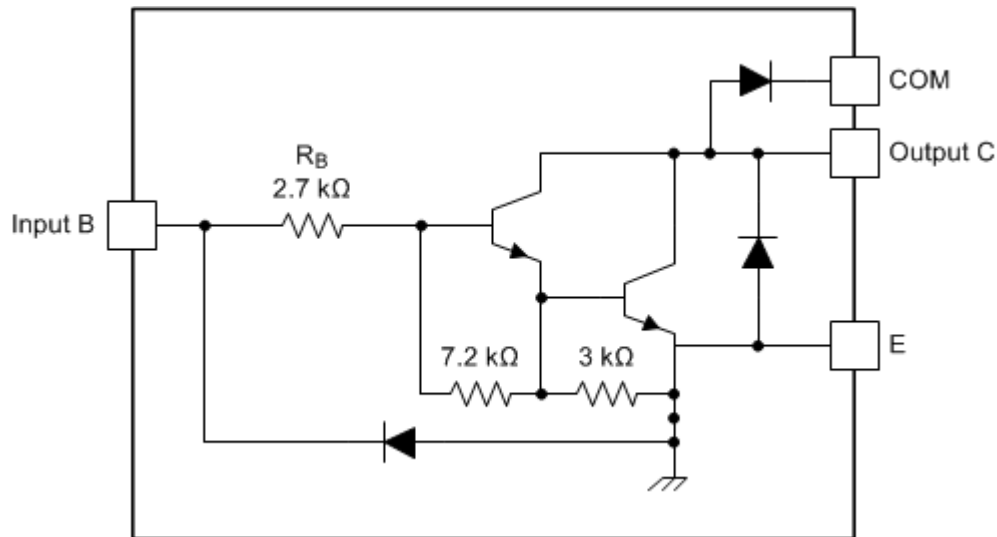

Figure 2-4. ULN2003A Darlington Array Circuit

- The **TLV76050** is used as the LDO for the isolated power rail to provide a 5V output for the field side. This device is very low cost and provides enough current to drive multiple relay channels from the field side of the ISO7740. A PWM from the MCU is used to generate the isolated power rail as shown in [Figure 2-5](#). The output of the secondary side is used by the Darlington array, and the LDO output is used for the field side of the digital isolator. More information on the SSR circuitry can be found in the [24-VAC Multi-Channel Solid-State Relay Reference Design Using Digital Isolator](#).

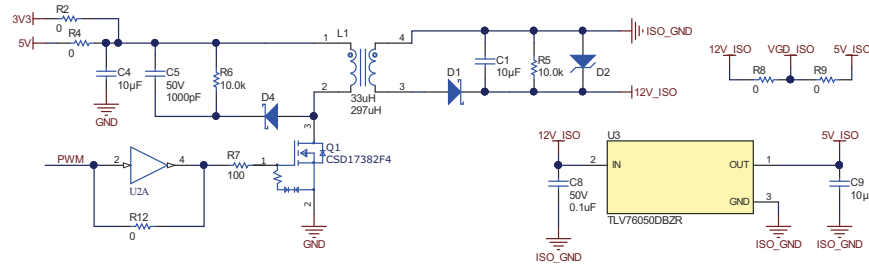

Figure 2-5. Open Loop Flyback for Isolated Relay Control

**Freeze Detection:** For water based systems needing freeze detection, a temperature and humidity sensor can be used to indicate this event. This design leverages the HDC2010 which is a low-cost digital temperature and humidity sensor that can be mounted on the mitigation board, or even off-board near the heat exchanger depending on the use case as shown in [Figure 2-6](#). The HDC2010 is a humidity and temperature sensor that provides high accuracy measurements with very low power consumption. The sensor is factory-calibrated to 0.2°C temperature accuracy and 2% relative humidity accuracy and includes a heating element to burn away condensation and moisture for increased reliability.

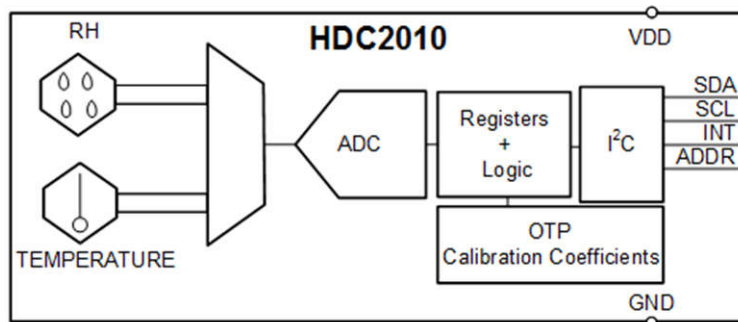
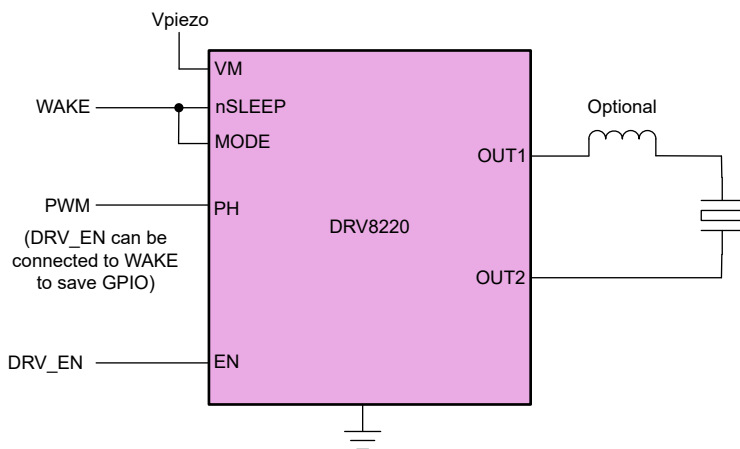

Figure 2-6. HDC2010 Functional Block Diagram

**Audio Driver:** For the audio alarm, the DRV8220 is selected as a low cost piezo driver. Although this device is marketed as a half-bridge motor drive, the device can also be leveraged as a piezo speaker driver for the audio alarm. The DRV8220 supports multiple control interface modes including PWM (IN1/IN2), phase/enable (PH/ EN), independent half-bridge, and parallel half-bridge. Each interface supports a low-power sleep mode to achieve ultra-low quiescent current draw by shutting down most of the internal circuitry. The device can supply up to 1.76A of output current and operates with a supply voltage from 4.5 to 18V as shown in [Figure 2-7](#).



**Figure 2-7. DRV8220 Piezo Speaker Driver Block Diagram**

**Fieldbus Interface:** For the fieldbus communication, there are a variety of communication interfaces that can be chosen based on the target communication protocol. Many sensor modules on the market today use RS-485 as the primary communication protocol between the sensor module and the mitigation control board. For this reason, the THVD1500 is chosen as the communication interface for the example mitigation control board as shown in [Figure 2-8](#). The THVD1500 is a low-cost, low-power half-duplex RS-485 transceiver designed for data transmission up to 500kbps.

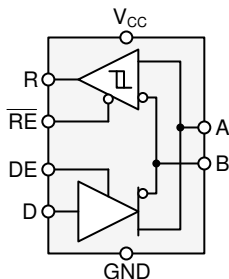

**Figure 2-8. THVD1500 Functional Block Diagram**

## 2.1 Overview of Mitigation Board Functions

The following section provides greater details on the specific mitigation tasks outlined in the UL60335-2-40 standard mentioned in the aforementioned section. In addition to the task requirements, there are also applicable TI reference designs that can provide a starting point for designers (schematics, PCB layout, and software).

### 2.2 Audible and Visible Detection Alarm

Another requirement for new HVAC systems complying with the UL60335-2-40 is the audible and visual indication that a refrigerant leak has been detected. Typically, these can be located on or near the indoor air handler where the hazard can be most likely to be a potential fire risk.

According to the standard, refrigerant leak alarms (in accordance with GG.13.2.2) for general occupancy shall warn both audibly and visibly, such as both a loud 15dBA above background level buzzer and a flashing light installed where:

- Sleeping facilities
- People restricted in the movement

- Uncontrolled number of people are present
- Any space someone has access to without personally being acquainted with necessary safety precautions

**TI collateral for designers:** [Status Indication Reference Design with LED and Audio Feedback.](#)

**Design Overview:** The TIDA-03026 reference design functionality emulates status indication subsystems in various end equipments and can be used for these A2L detection systems. Audio feedback is also integrated to show a combined status indication design with LEDs and audio.

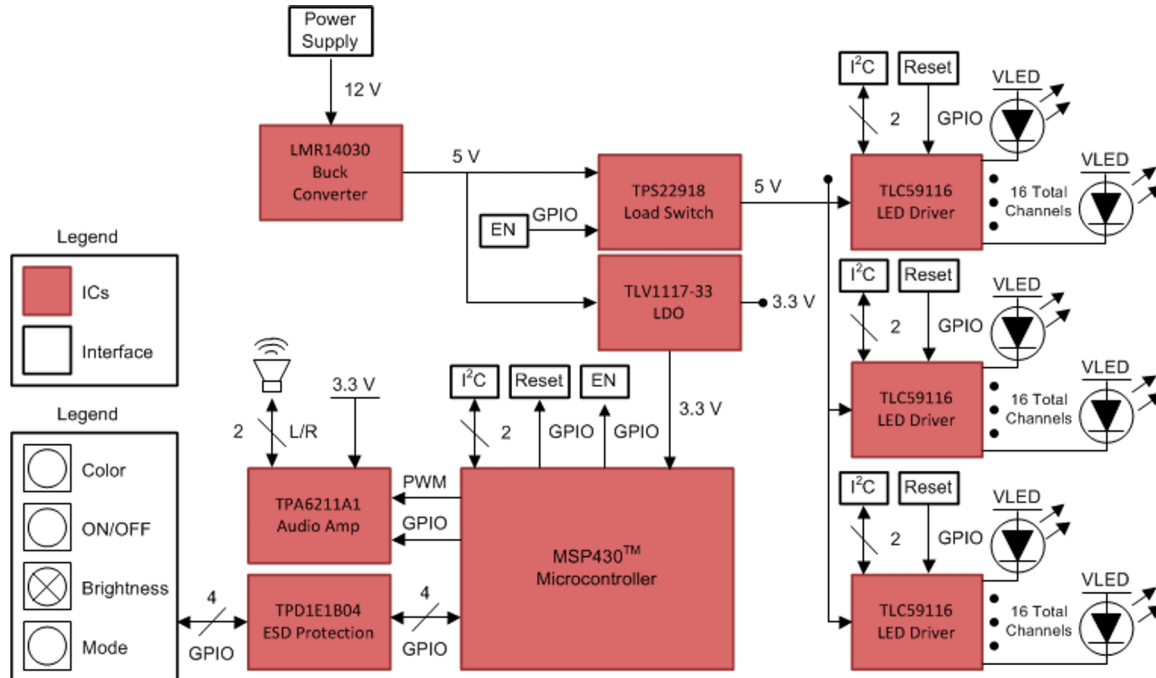

**Figure 2-9. TIDA-03026 Reference Design Block Diagram**

#### Features:

- Synchronize multiple LED drivers using variable PWM to create unique pulsing, blinking, and breathing effects with TLC59116
- TLC59116 I2C control makes adding additional LEDs simple by enabling user-experience customization across multiple platforms
- Easy-to-use TPA6211A1 audio amplifier simplifies audio design for faster time to market
- TPS22918 load switch drops LED driver standby current to 0.5 $\mu$ A, saving power for efficient system design

### 2.3 Freeze Detection (Water-Based Systems)

For systems with a secondary heat exchanger (air-to-water, water to water, chillers), the heat exchanger shall not allow the release of refrigerant into areas served by the secondary heat exchanger fluids by implementing one or more of the following:

- Double wall heat exchanger
- Refrigerant system where the pressure of secondary circuit is always greater than that of the primary circuit in area of contact
- Implementation of a freeze protection device where:
  - Circulation pump is switched off
  - Freeze protection shuts off compressor
  - Depending on application, Safety shut off valves with spring return for electrical power failure safety

**TI collateral for designers:** [Low-Power Flood and Freeze Detector Reference Design with Sub-1 GHz and 10-Year Coin Cell Battery Life.](#)



**Design Overview:** This reference design uses Texas Instruments low-power consumption digital dual temperature and humidity sensors and the SimpleLink™ ultra-low power Sub-1 GHz wireless microcontroller (MCU) platform to demonstrate a flood and freeze detector with extremely long battery life and no wiring required.

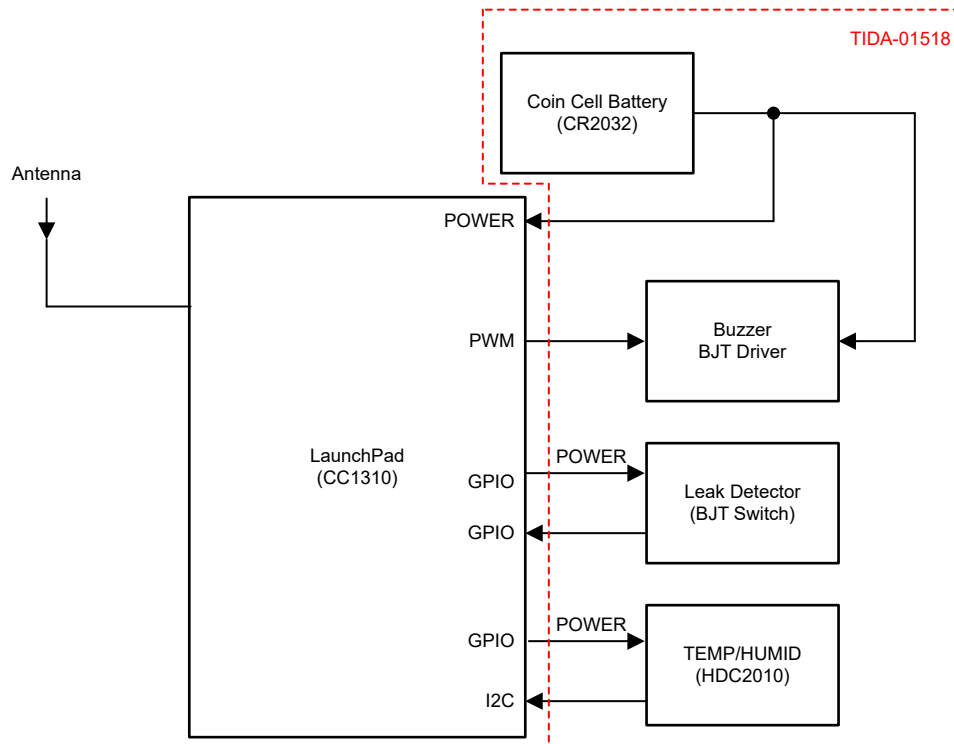

Figure 2-10. TIDA-01518 Reference Design Block Diagram

**Features:**

- Ultra-low-power design resulting in 10-year battery life from single CR2032 coin cell
- Conductive water sensing always powered on to enable continuous monitoring
- Designed for SimpleLink™ Sub-1 GH CC1310 wireless microcontroller (MCU) LaunchPad™ development kit (LAUNCHXL-CC1310)
- Ability to take high-resolution temperature and humidity data
- Simple design that leads to lower cost

**2.4 Isolation and or Safety Shut-off Valves (SSOVs) in the Refrigeration System to Limit Releasable Charge**

According to 101.DVN.9 of the UL standard, HVAC systems considered partial units (split systems, outdoor condenser, for example) must have safety shut-off valves factory or field installed and capable of being controlled from signal from the compressor control board. These safety valves shall be non-self-resetting, and requires a manual reset operation, and shall not be capable of remote reset.

**TI collateral for designers:** [Damper and EEV Controller Reference Design with Power Regulation and Hall-Effect Position Sensing](#)

**Design Overview:** This reference design demonstrates a dual motor drive design for damper actuators and electronic expansion valves. The multiple motor drives include one bipolar stepper motor driver, one brushless DC motor driver, operating from a 15VDC source. The design shows accurate power limiting that helps for easy qualification as a low-power circuit, defined by IEC 60335-1. This reference design incorporates a 0-10V and 4-20mA control interface for controlling the position of the valve or damper, and a TMAG5273 which is used for accurate position sensing.

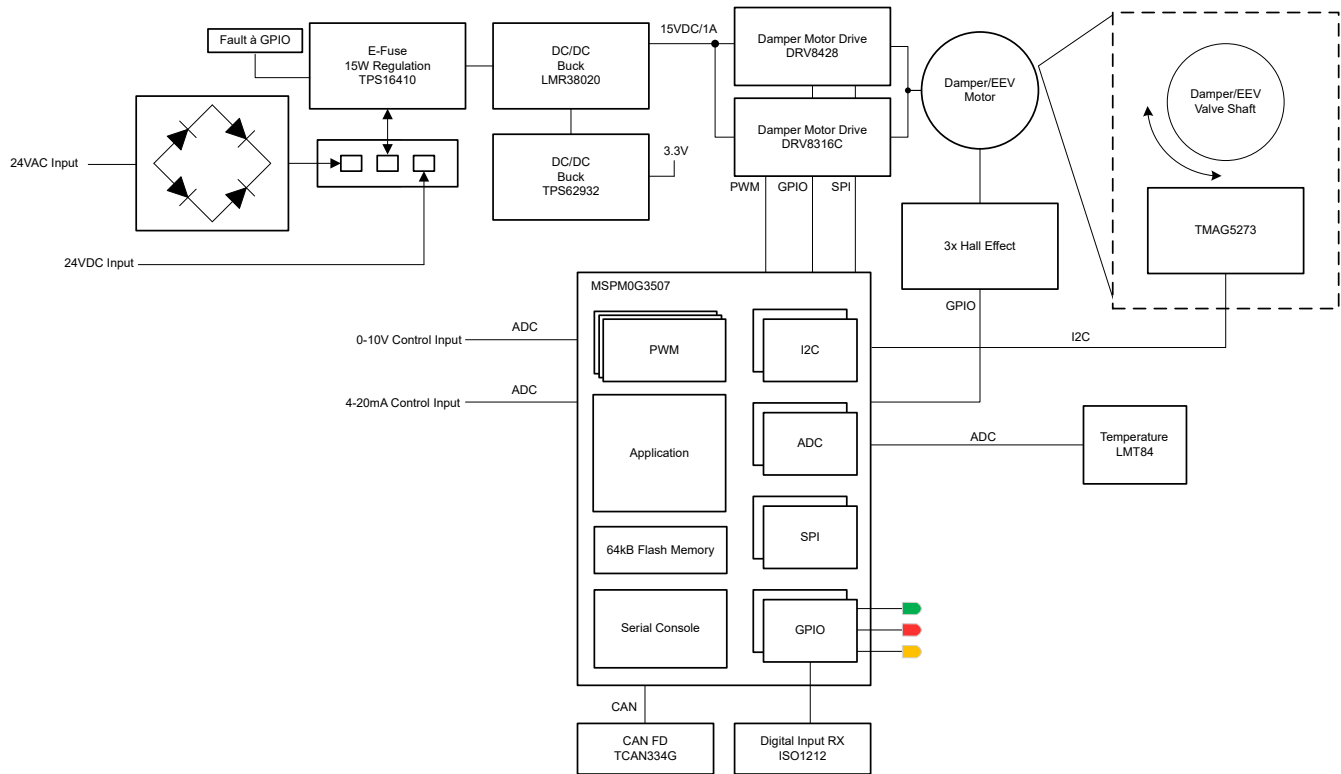

Figure 2-11. TIDA-010950 Reference Design Block Diagram

**Features:**

- Operates at voltage ranging from 24V to 40V
- Brushless DC drive for electronic expansion device control
- Bipolar stepper drive DRV8428 efficiency > 95 %
- Single MCU control with multi-peripheral device operation through I2C and SPI
- 15W power regulation to help easy low-power circuit qualification with IEC 60335-1
- 0-10V and 4-20mA control front-end

**2.5 Electronic Controls With A2L Logic to Perform Required Actions in The Event of a Leak — Such as Shutting off the Compressor and or Other Components**

If leak is detected, the following actions must be taken and continued for at least 5 minutes after the refrigerant detection system has reset:

- Indoor blower fan is switched on
- Fully open all zoning dampers on appliance and energize control signals for external zoning dampers if applicable
- Disable the compressor operation, unless compressor operation reduces the leakage rate, or the total amount released in the indoor space

**TI collateral for designers:** [24-VAC Multi-Channel Solid State Relay Reference Design Using Digital Isolator.](#)

**Design Overview:** This reference design features a multi-channel solid-state relay (SSR) using a single isolation. It employs a multi-channel digital isolator with a common ground gate-drive circuit and a single isolated power supply to independently control multiple SSRs. The design supports 24-VAC relays with up to 2A current, scalable to 240 VAC and higher currents. Each SSR channel is compact, consuming less than 75mm<sup>2</sup> with a maximum component height of 3mm. The single isolated power supply minimizes board space and reduces BOM cost compared to electromechanical relays.

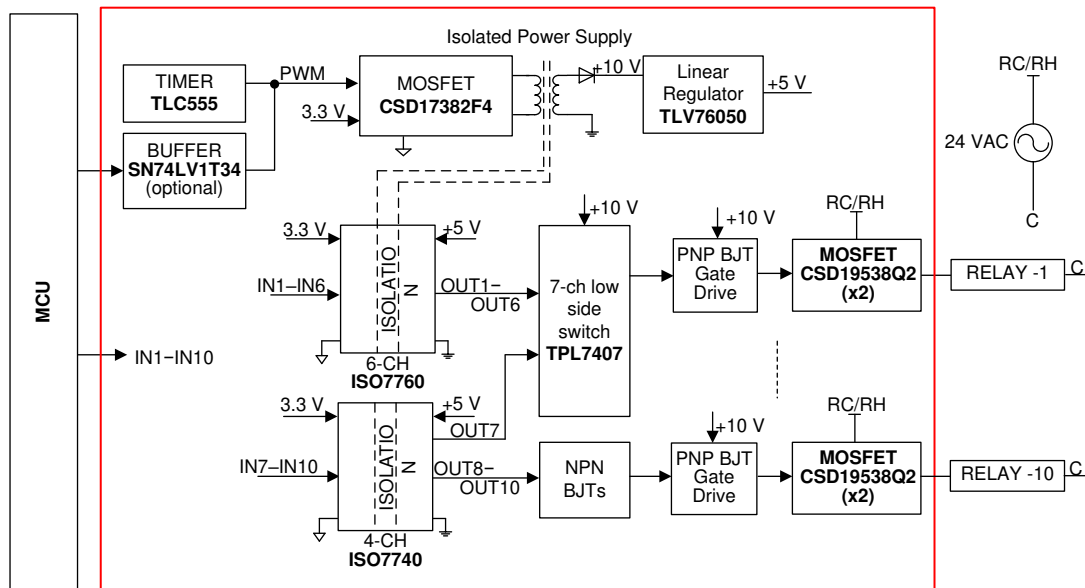

Figure 2-12. TIDA-010085 Reference Design Block Diagram

**Features:**

- Multiple solid-state relays using a single isolation with multichannel digital isolator, easily scalable to any number of SSR channels with minimum extra cost
- SSR drive voltage 24 VAC  $\pm 20\%$ , drive current 2A RMS (voltage and current rating, scalable by using appropriately rated components)
- SSR turn on and turn off time: 15–300  $\mu\text{s}$  (adjustable), average current consumption per SSR drive (referred to primary) < 4mA (adjustable down to 20 $\mu\text{A}$  per channel)
- SSR size < 75mm<sup>2</sup> per channel. Height is around 3mm.
- Functionally isolated open-loop flyback-based power supply without the need of an MCU
- Surge and switching overvoltage protection

**2.6 Ventilation and or Circulation Fans Within Cases or Walk-in Units**

For indoor units where H0 is <1.8m, as well as indoor units connected to one or more spaces via ducts which supply or return air from the space at a height <1.8m, circulation airflow for the purpose of mixing the air in the room shall be provided. This circulation needs to operate continuously, or be turned on by the refrigerant detection systems, also turning off the compressor unless the compressor operation reduces the leak rate, or the total amount released to the indoor space.

**TI collateral for designers:** [TIDA-010265 750-W Motor Inverter with C2000™ and MSPM0 Reference Design](#)

**Design Overview:** This reference design is a 750W motor drive for washing machines or similar equipment, demonstrating sensorless field-oriented control (FOC) for a three-phase PMSM using either FAST software or an enhanced sliding-mode observer (eSMO). It supports both C2000™ and MSPM0 MCUs with a modular design. The ready-to-use hardware and software accelerate time to market. The design guide includes hardware details and test results. A MathWorks model-based approach facilitates faster development, requires fewer resources, and is portable across C2000 microcontroller families, allowing for offline development, tuning, and validation.

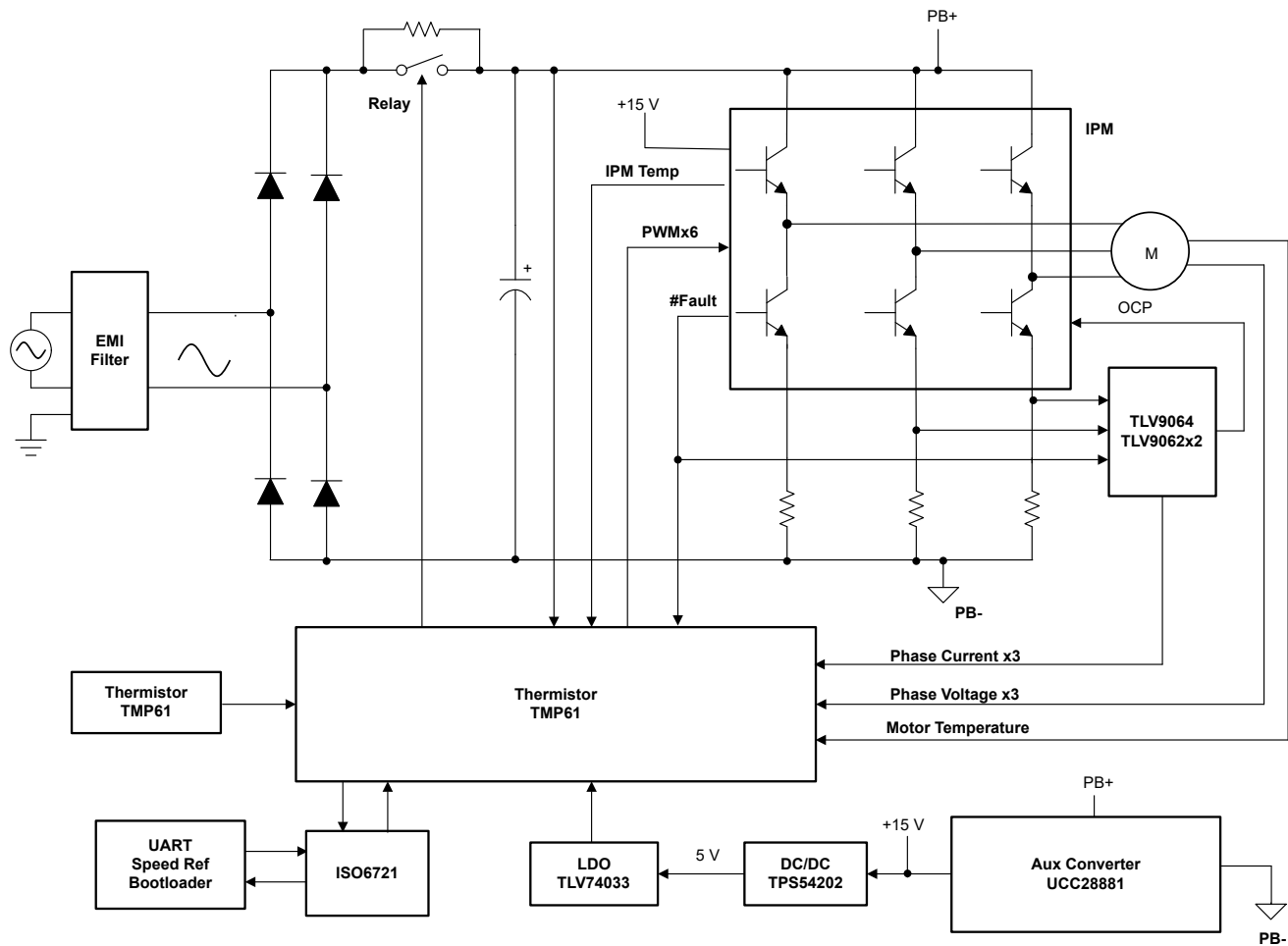

Figure 2-13. TIDA-010265 Reference Design Block Diagram

**Features:**

- Wide operating voltage input range of 165V to 265VAC and 50Hz or 60Hz
- Up to 750W inverter stage, 15kHz switching frequency, torque compensation, and automatic field weakening control
- Modular design with either C2000 MCU or MSPM0 controller daughterboard on the same power motherboard
- FOC motor control, supports both FAST and eSMO
- User-friendly graphical user interface to control, identify and monitor the motor
- C2000™ microcontroller (MCU) motor control software and accompanying GUI is available in the C2000WARE-MOTORCONTROL-SDK version 5\_01 and newer.
- Model-based design using MathWorks MATLAB and Simulink is available in C2000WARE-MOTORCONTROL-SDK version 5\_02 and newer. The design demonstrates model-based motor control with support for various sensorless observers and current sensing methods.

**TI collateral for designers:** [250W Motor Inverter Reference Design With GaN IPM DRV7308](#)

**Design Overview:** This reference design is a 250W motor drive for major appliances, featuring a GaN IPM DRV7308-based high-efficiency motor inverter that operates without a heatsink, and includes a low standby power design with UCC28911. The design demonstrates sensorless FOC control for a 3-phase PMSM using FAST™ software or eSMO. The modular design supports both C2000™ and MSPM0 microcontrollers on the

same motherboard. The tested and ready-to-use hardware and software help speed up development time. Design details and test results are provided in the design guide.

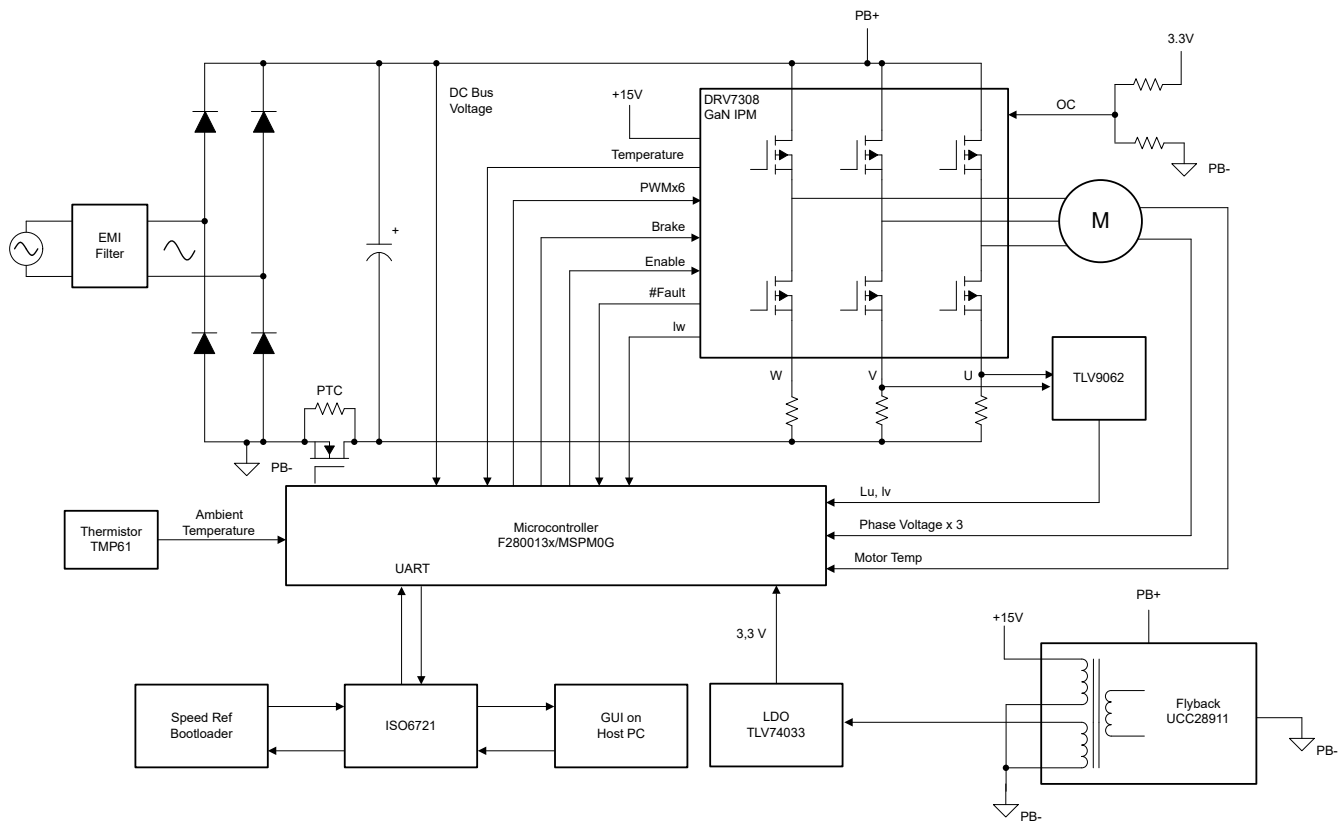

**Figure 2-14. TIDA-010273 Reference Design Block Diagram**

## Features

- Peak efficiency >99%
- No heatsink needed for up to 250W inverter stage, 15kHz switching frequency
- 80mm by 55mm compact board size
- Low-standby power design
- Modular design with either C2000 or MSPM0 controller daughterboard on the same power motherboard
- Sensor-less field-oriented control (FOC) motor control, supports both FAST and eSMO
- User-friendly graphical user interface (GUI) to control, identify, and monitor the motor

### 3 Summary

In summary, A2L refrigerants offer significant environmental benefits, including low global warming potential (GWP) and zero ozone depletion potential (ODP), along with improved energy efficiency compared to older refrigerants like R-410A and R-22. However, the mild flammability necessitates stringent safety measures, including the use of refrigerant detection systems (RDS) and mitigation boards, to prevent combustion risks. Adherence to safety standards like UL 60335-2-40 is crucial for making sure safe operation in HVAC systems, balancing the environmental advantages of A2L refrigerants with the need for rigorous safety protocols. TI offers a multitude of devices and reference designs to help accelerate the design process for mitigation control boards, offering designers better performance at lower cost.

### 4 References

1. Texas Instruments, [A2L Refrigerant Adoption: Considerations and Requirements](#), application brief.
2. Texas Instruments, [24-VAC Multi-Channel Solid-State Relay Reference Design Using Digital Isolator](#).
3. Texas Instruments, [Status Indication Reference Design with LED and Audio Feedback](#).
4. Texas Instruments, [Low-Power Flood and Freeze Detector Reference Design with Sub-1 GHz and 10-Year Coin Cell Battery Life](#).
5. Texas Instruments, [Damper and EEV Controller Reference Design with Power Regulation and Hall-Effect Position Sensing](#).
6. Texas Instruments, [750-W Motor Inverter with C2000™ and MSPM0 Reference Design](#).
7. Texas Instruments, [250W Motor Inverter Reference Design With GaN IPM DRV7308](#).
8. Texas Instruments, [MSPM0G3507 80MHz Arm® Cortex®-M0+ MCU with 128KB flash 32KB SRAM 2x4Msps ADC, DAC, 3xCOMP, 2xOPA, CAN-FD, MATHA](#), product page.
9. Texas Instruments, [ISO7740 Robust EMC, Quad-Channel, 4/0, Reinforced Digital Isolator](#), product page.
10. Texas Instruments, [ULN2003A 50V 7-ch Darlington Transistor Array](#), product page.
11. Texas Instruments, [TLV76050 100-mA, 30-V, Low-Dropout Voltage Regulator](#), product page.
12. Texas Instruments, [HDC2010 2% RH Ultra-Small, Low-Power Digital Relative Humidity Sensor](#), product page.
13. Texas Instruments, [DRV8220 20-V, 1.76-A H-Bridge Motor Driver With Auto Sleep Mode](#), product page.
14. Texas Instruments, [THVD1500 5-V RS-485 Transceiver up to 500 Kbps With ±8-kV IEC ESD protection](#), product page.

## IMPORTANT NOTICE AND DISCLAIMER

TI PROVIDES TECHNICAL AND RELIABILITY DATA (INCLUDING DATA SHEETS), DESIGN RESOURCES (INCLUDING REFERENCE DESIGNS), APPLICATION OR OTHER DESIGN ADVICE, WEB TOOLS, SAFETY INFORMATION, AND OTHER RESOURCES "AS IS" AND WITH ALL FAULTS, AND DISCLAIMS ALL WARRANTIES, EXPRESS AND IMPLIED, INCLUDING WITHOUT LIMITATION ANY IMPLIED WARRANTIES OF MERCHANTABILITY, FITNESS FOR A PARTICULAR PURPOSE OR NON-INFRINGEMENT OF THIRD PARTY INTELLECTUAL PROPERTY RIGHTS.

These resources are intended for skilled developers designing with TI products. You are solely responsible for (1) selecting the appropriate TI products for your application, (2) designing, validating and testing your application, and (3) ensuring your application meets applicable standards, and any other safety, security, regulatory or other requirements.

These resources are subject to change without notice. TI grants you permission to use these resources only for development of an application that uses the TI products described in the resource. Other reproduction and display of these resources is prohibited. No license is granted to any other TI intellectual property right or to any third party intellectual property right. TI disclaims responsibility for, and you will fully indemnify TI and its representatives against, any claims, damages, costs, losses, and liabilities arising out of your use of these resources.

TI's products are provided subject to [TI's Terms of Sale](#) or other applicable terms available either on [ti.com](https://www.ti.com) or provided in conjunction with such TI products. TI's provision of these resources does not expand or otherwise alter TI's applicable warranties or warranty disclaimers for TI products.

TI objects to and rejects any additional or different terms you may have proposed.

Mailing Address: Texas Instruments, Post Office Box 655303, Dallas, Texas 75265  
Copyright © 2024, Texas Instruments Incorporated