

Automotive Audio Design Considerations to Minimize Amplifier Size and Thermal Load



Gregg Burke
Product Marketing
Texas Instruments

The audio solution integrated in a vehicle's infotainment system may vary from the typical four audio channels – two speakers in the front and two speakers in the back – to newer solutions that drive six or eight total speakers without the need for an external amplifier.

These higher-channel-count systems in an infotainment system may integrate:

- A center speaker.
- Separate tweeter/midrange/woofer speakers.
- Instrument cluster chimes or warning tones.
- Additional speakers to communicate information, such as warning drivers to take control of steering or braking if the vehicle is operating in a semi-autonomous driving mode.

Some higher-end car models may actually have as many as 20 speakers. The speakers in these audio systems are driven by an external amplifier typically placed near the trunk of the car. These audio systems also incorporate more advanced sound algorithms such as active noise cancellation to deliver a more personalized audio experience.

With each subsequent model year, automakers are adding more and more electronics. Coupled with the need to drive six to eight speakers directly from the infotainment system, space behind the dashboard is now at an all-time premium. Therefore, it's becoming a priority for audio hardware designers to develop smaller automotive audio amplifier solutions with lower heat dissipation. In this paper, I'll describe four factors that drive overall audio amplifier size:

- Efficiency/thermal performance.
- Switching frequency.
- Inductor size.
- Package design.

Efficiency/thermal performance

Designers have traditionally designed car radios using Class-AB linear audio amplifiers. Class-AB linear amplification is drastically less efficient than the newer but well-established Class-D switching technology. **Figure 1** highlights the difference.

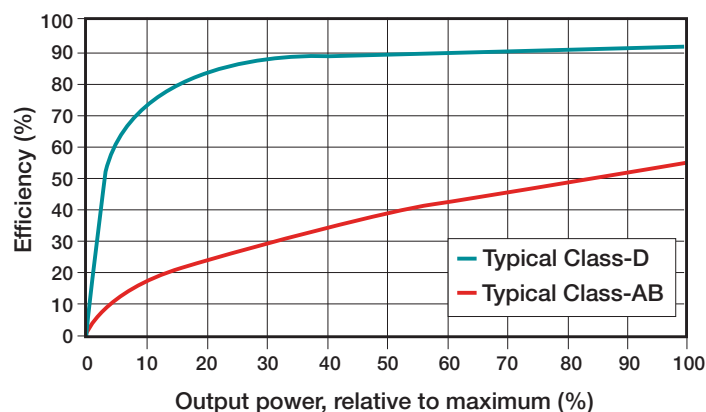

Figure 1. Class-D vs. Class-AB efficiency.

Class-AB efficiency loss leads directly to additional internal heat generation, which then requires dissipation outside the audio amplifier. The need for a larger heat sink in Class-AB designs also exacerbates the challenge to continuously reduce the overall automotive audio amplifier system solution size.

Class-D amplifiers can achieve the same output power but dissipate significantly less heat, enabling designers to use a much smaller and less complex heat sink to transport dissipated power to the ambient environment.

Switching frequency

The number of electronics mounted behind the dashboard in a relatively tight space increases the possibility that circuits can emit interfering signals in close proximity. Ultimately, modern radios and audio amplifiers must provide better immunity from electromagnetic interference (EMI) in the AM band to meet these challenges.

In the U.S., AM radio stations broadcast in the 535-kHz to 1705-kHz frequency band. Existing Class-D audio amplifier designs typically operate with a fundamental switching frequency in the 400-kHz to 500-kHz range. These lower-switching-frequency Class-D amplifier designs create harmonics that occur directly within the AM band, as shown in **Figure 2**.

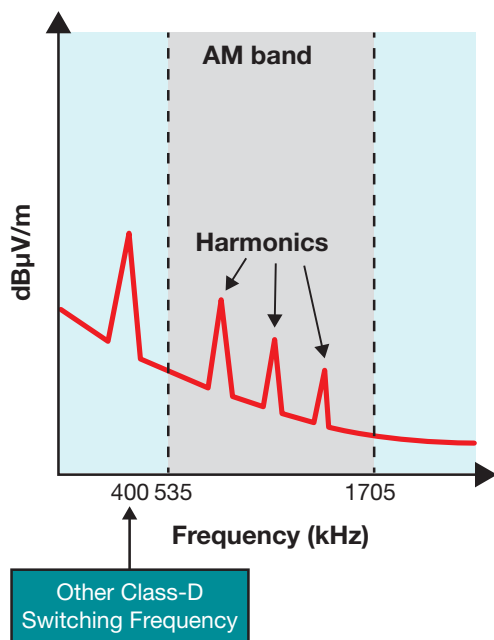

Figure 2. Typical 400-kHz Class-D amplifier harmonics.

The harmonics create interfering signals that reduce the sensitivity of the AM receiver, thereby hindering AM radio station reception. Implementing an AM avoidance scheme on Class-D amplifier designs mitigates the effects of these harmonics.

Class-D audio amplifiers require reconstruction filters to convert the pulse-width modulation (PWM) signal from the amplifier output into the desired analog audio signal. These output filters are made with inductors (L) and capacitors (C) (as shown in **Figure 3**) for a typical bridge-tied load (BTL)

amplifier circuit, and help minimize EMI from the high-speed switching transients on the output stages of Class-D amplifiers.

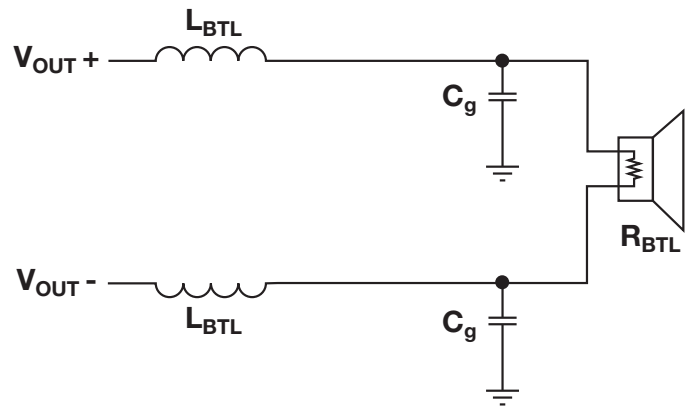

Figure 3. A Class-D amplifier BTL circuit.

Automotive Class-D audio amplifiers that operate at a 2.1-MHz switching frequency provide significant margin above the AM band, as shown in **Figure 4**. This design is free of any lower-frequency spikes that would interfere with the AM band, thus eliminating the need for an AM avoidance scheme.

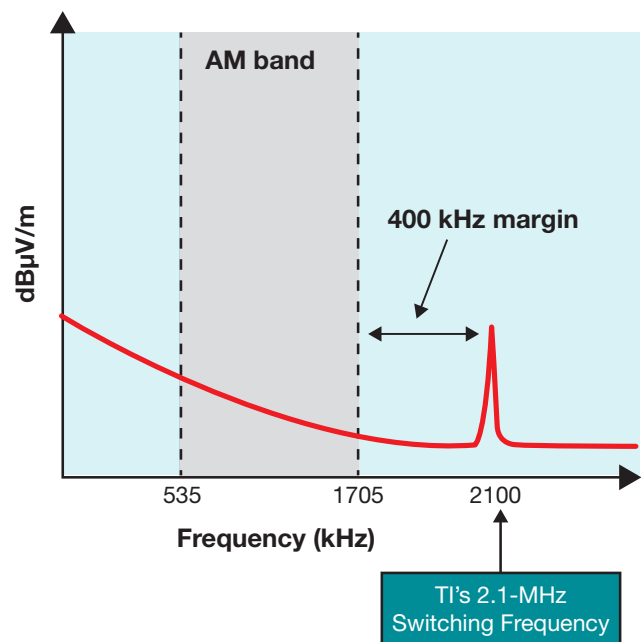

Figure 4. 2.1-MHz high switching frequency.

As an additional benefit, a 2.1-MHz switching frequency enables a lower inductance value for the output filter due to the inherent reduction in ripple current. A lower inductance for an equivalent current rating leads to a smaller inductor, reducing printed circuit board (PCB) area and subsequently the EMI footprint.



Figure 5. Comparison of inductor size vs. switching frequency.

Inductor size

For Class-D automotive audio amplifiers, the value of the inductor required in the LC filter to ensure the proper PWM demodulation filter characteristic depends on the switching frequency. As shown in **Figure 5**, a 400-kHz automotive audio amplifier typically uses either a 10- μH or 8.2- μH inductor value, while a 2.1-MHz higher-switching-frequency amplifier design can take advantage of a much smaller and lighter-weight inductor in the range of 3.3 μH to 3.6 μH (assuming that each amplifier provides the same output power).

As I mentioned earlier, a typical car radio design has at least four channels to drive two front speakers and two rear speakers. This simple configuration requires eight inductors for a Class-D automotive audio amplifier, since each channel requires two inductors, as shown earlier in Figure 3. Thus, the size of each inductor is multiplied by 8, which is a significant contribution to overall PCB size and design weight. As a general reference, the transition from 8.2- μH inductors to 3.3- μH inductors can save over 85% in inductor space on the PCB and over 85% in weight.

Package design

Another audio amplifier consideration that can greatly contribute to the overall system solution size of an automobile’s infotainment system is the design of the amplifier package.

A square-shaped package design has inputs on the bottom of the package and two audio outputs with LC filters orthogonally placed on either side of the amplifier. As you can see in **Figure 6**, this type of package design greatly contributes to the overall PCB footprint.

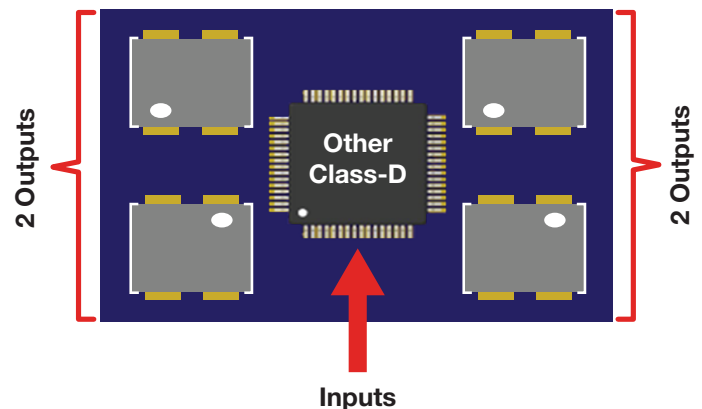

Figure 6. Square four-channel audio amplifier package design.

A better option is a rectangular package that has a “flow-through” audio signal design. **Figure 7** illustrates how the analog input signals come into the amplifier on one side of the chip; amplification of the audio signal takes place on the opposite side of the amplifier, where the signals are then delivered into external output filters.

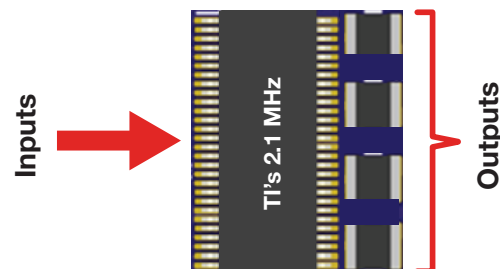

Figure 7. Flow-through four-channel audio amplifier package design.

The [TPA6304-Q1](#) audio amplifier uses a 2.1-MHz high-switching-frequency Class-D amplifier technology that features TI Burr-Brown™ technology. By combining 3.3-μH metal alloy inductors and a flow-through package design, the TPA6304-Q1 delivers a four-channel automotive Class-D amplifier solution size that measures only 17 mm by 16 mm. See [Figure 8](#).

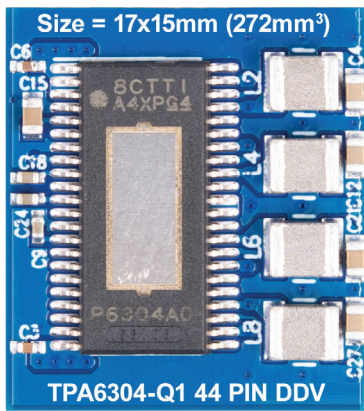
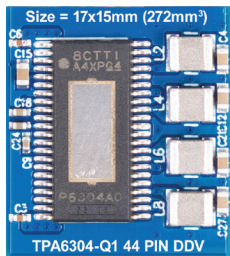

Figure 8. The TPA6304-Q1 four-channel Class-D amplifier solution.

The TPA6304-Q1, including all of the passive electronic components for the full system solution implementation, is even smaller than the traditional Class-AB amplifier by itself, as shown in [Figure 9](#).



TPA6304-Q1
measures 272 mm²



Traditional
Class-AB

Figure 9. TPA6304-Q1 Class-D amplifier solution size compared to a Class-AB amplifier.

Conclusion

The more electronics added to a car, the more the overall heat signature increases in an already tightly confined space behind the dashboard. Thus, the challenge for automotive audio hardware designers is to implement smaller and smaller audio solutions with lower and lower heat dissipation. Audio amplifier efficiency will only become more important in the future of infotainment system design.

The TPA6304-Q1 makes replacing a Class-AB automotive audio amplifier easy. Its 2.1-MHz switching frequency and tiny system solution size allow you to achieve Class-D efficiency at a Class-AB system cost.

Related websites

Learn more about the [TPA6304-Q1](#).

Learn more about [transitioning from Class-AB to Class-D amplifiers](#).

Important Notice: The products and services of Texas Instruments Incorporated and its subsidiaries described herein are sold subject to TI's standard terms and conditions of sale. Customers are advised to obtain the most current and complete information about TI products and services before placing orders. TI assumes no liability for applications assistance, customer's applications or product designs, software performance, or infringement of patents. The publication of information regarding any other company's products or services does not constitute TI's approval, warranty or endorsement thereof.

The platform bar and Burr-Brown are trademarks of Texas Instruments.
All other trademarks are the property of their respective owners.

IMPORTANT NOTICE AND DISCLAIMER

TI PROVIDES TECHNICAL AND RELIABILITY DATA (INCLUDING DATASHEETS), DESIGN RESOURCES (INCLUDING REFERENCE DESIGNS), APPLICATION OR OTHER DESIGN ADVICE, WEB TOOLS, SAFETY INFORMATION, AND OTHER RESOURCES "AS IS" AND WITH ALL FAULTS, AND DISCLAIMS ALL WARRANTIES, EXPRESS AND IMPLIED, INCLUDING WITHOUT LIMITATION ANY IMPLIED WARRANTIES OF MERCHANTABILITY, FITNESS FOR A PARTICULAR PURPOSE OR NON-INFRINGEMENT OF THIRD PARTY INTELLECTUAL PROPERTY RIGHTS.

These resources are intended for skilled developers designing with TI products. You are solely responsible for (1) selecting the appropriate TI products for your application, (2) designing, validating and testing your application, and (3) ensuring your application meets applicable standards, and any other safety, security, or other requirements. These resources are subject to change without notice. TI grants you permission to use these resources only for development of an application that uses the TI products described in the resource. Other reproduction and display of these resources is prohibited. No license is granted to any other TI intellectual property right or to any third party intellectual property right. TI disclaims responsibility for, and you will fully indemnify TI and its representatives against, any claims, damages, costs, losses, and liabilities arising out of your use of these resources.

TI's products are provided subject to TI's Terms of Sale (www.ti.com/legal/termsofsale.html) or other applicable terms available either on ti.com or provided in conjunction with such TI products. TI's provision of these resources does not expand or otherwise alter TI's applicable warranties or warranty disclaimers for TI products.

Mailing Address: Texas Instruments, Post Office Box 655303, Dallas, Texas 75265
Copyright © 2019, Texas Instruments Incorporated