

# How to Design System Level Functional Safety for Automotive Displays



Andy Ye, Gracie Guo, Michael Yeh, and Zack Liu

## ABSTRACT

Automotive displays have become a key feature inside vehicles. These displays can show a variety of information, from drive speed to real-time navigation to safety notices, which means these displays must comply with functional safety standards. This paper discusses how to meet system level functional safety requirements for automotive TFT-LCD with TI solutions.

## Table of Contents

<b>1 Introduction</b> .....	2
<b>2 Typical Local Dimming System</b> .....	2
<b>3 ASIL-B Design for LED Power</b> .....	3
<b>4 Functional Safety Design for LED Driver</b> .....	5
<b>5 Summary</b> .....	6
<b>6 Reference</b> .....	6

## List of Figures

Figure 2-1. Typical Local Dimming System Block Diagram.....	2
Figure 3-1. Typical Cold Crank Profile.....	3
Figure 3-2. TPS552892-Q1 Typical Application Circuit.....	3
Figure 3-3. TPS552892-Q1 Output Detection by MCU Mechanism.....	4
Figure 3-4. TPS552892-Q1 Output Detection by supervisor TPS37A-Q1.....	5
Figure 4-1. Local Dimming Typical Application Daisy-Chaind TLC6C5748-Q1 Devices.....	5
Figure 4-2. TLC6C5748-Q1 LOD and LSD Circuit.....	6

## List of Tables

Table 3-1. Power Supply Safety Mechanism From ISO26262.....	4
Table 4-1. TLC6C5748-Q1 LOD and LSD Truth Table.....	6

## Trademarks

FPD-Link™ is a trademark of Texas Instruments.  
All trademarks are the property of their respective owners.

## 1 Introduction

Today's newest vehicles have fewer knobs and buttons and instead rely on taps and swipes on a touchscreen to control a variety of functions. You can adjust mirrors and lights, turn on windshield wipers and set up your navigation. With this added functionality, the display panel size in cars is getting larger and larger. By 2025, 37-inch in-vehicle screens could be common with resolutions of 4K (on the order of 4,000 horizontal pixels) and eventually 8K. Traditional automotive displays use globally dimmed edge-lit backlight solutions but the light leakage from the LCD panel, which makes the black area not true black, could lead to a degraded viewing experience, especially when driving in the dark. Local dimming LCD backlight technology can help solve this problem.

Most of these automotive displays provide safety-relevant information through advanced driver assistance systems (ADAS) and digital instrument clusters, so they must comply with functional safety standards. The functional safety of automotive electronic/electrical systems is directed by ISO 26262. Automotive Safety Integrity Level (ASIL), which classifies the inherent safety risk in an automotive system, is an integral part of that standard. There are four ASIL levels: ASIL-A, ASIL-B, ASIL-C, and ASIL-D, with ASIL-D having the highest integrity requirements.

Automotive displays, like an instrument cluster display that includes various blocks, should meet the criteria outlined by ASIL-B. This document looks at how to meet system-level ASIL-B requirements using a TI local dimming LED Driver and LED power subsystem.

## 2 Typical Local Dimming System

Figure 2-1 is a typical infotainment local dimming system block diagram, which is comprised of a system board and an LED backlight board.

- The system board usually has a de-serializer, TCON (timing-controller), microcontroller (MCU), and some power supply circuits. The de-serializer receives video signal from a serializer on a cockpit or head unit through FPD-Link™, then transfers this signal to the TCON. The TCON accepts the image data stream, calculates and outputs the brightness data for each backlight zone. The MCU, usually used for power management, accepts the temperature sensor signal.
- The LED board usually has LED drivers, LED matrix, and temperature sensors. The system board and LED board are connected off-board using FPC cables.

Figure 2-1 shows each block that should meet functional safety standards. Let's discuss how the LED power and the light-emitting diode (LED) backlighting driver can be designed for ASIL-B compliance.

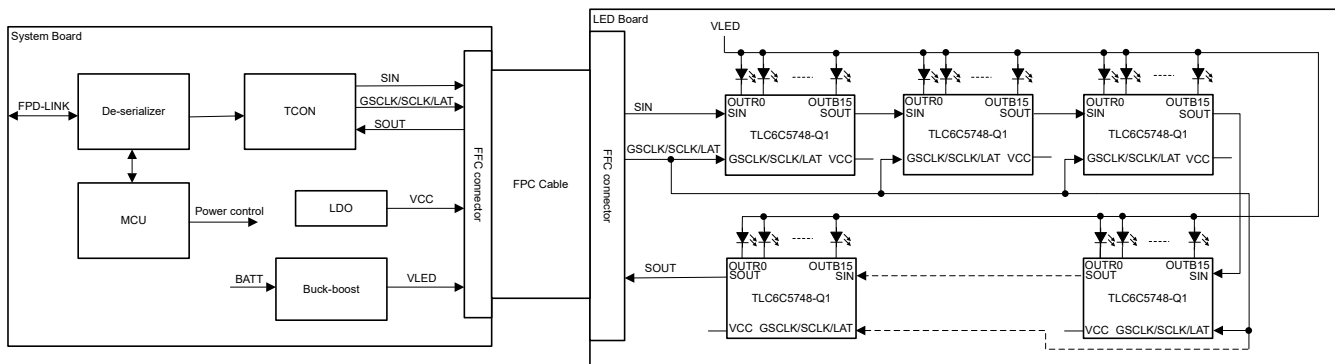

**Figure 2-1. Typical Local Dimming System Block Diagram**

### 3 ASIL-B Design for LED Power

For local dimming LCD applications, LED cathodes are connected to LED drivers and LED anodes are connected to LED power, as shown in Figure 2-1. For LED power, the input typically connects directly to the car battery. When you enter your car, the display is already turned on to welcome you. When you start the engine in cold weather,  $V_{IN}$  may go down to 3V during cold crank, as shown in Figure 3-1. However, the display still needs to be on or not blinking during cold crank to give the best user experience. You can put a pre-boost in front of the LED power, however, this can increase cost and lower efficiency. TI's buck-boost TPS552892-Q1 converter can handle as low as  $3V_{IN}$  after starting up with no external pre-boost or extra power supply.

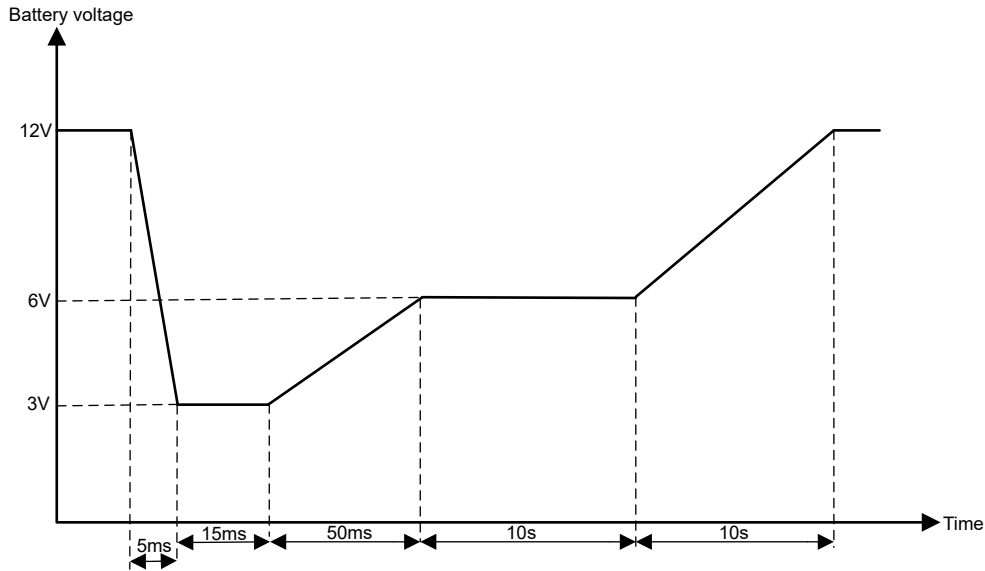

Figure 3-1. Typical Cold Crank Profile

The TPS552892-Q1 is a synchronous buck-boost converter that is optimized for converting battery voltage or adapter voltage into power supply rails. The TPS552892-Q1 converter integrates four MOSFET switches that can operate from 3.0V to 36V wide input voltage. For a 6V LED power application, the TPS552892-Q1 converter can deliver up to 36W from a  $12V_{IN}$ .

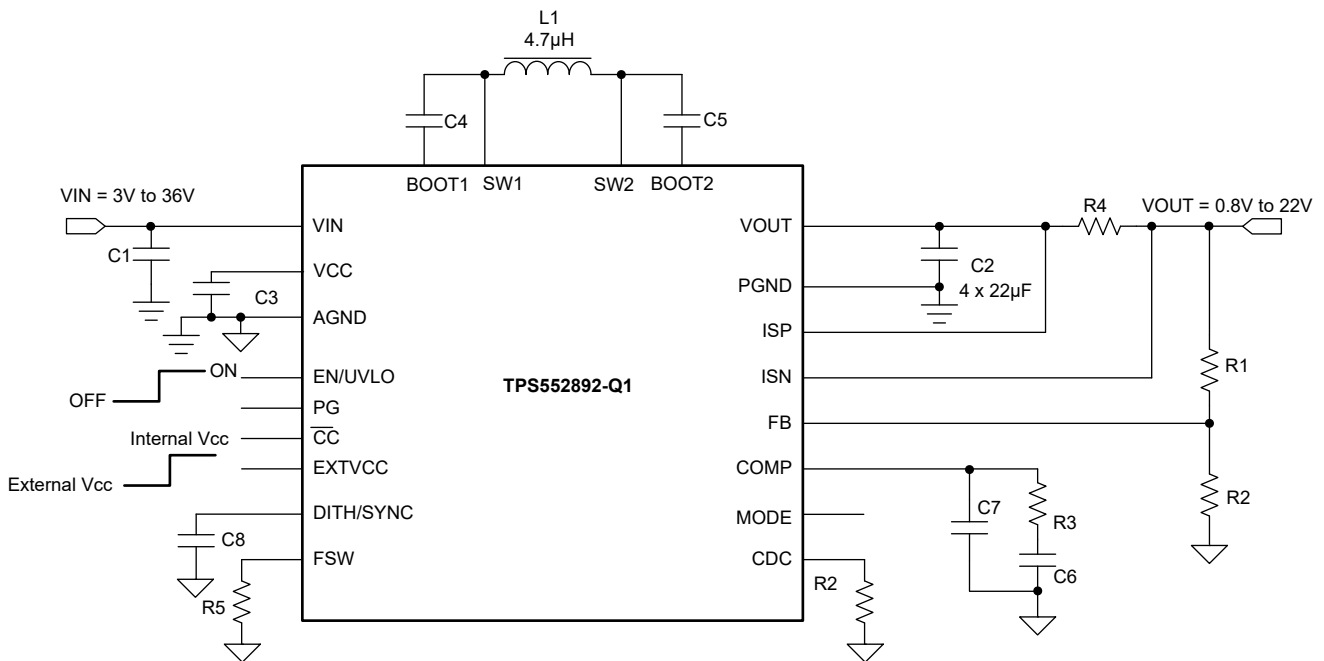

Figure 3-2. TPS552892-Q1 Typical Application Circuit

How can you design functional safety for LED power? Per the ISO26262-5 D.2.6 description, noted in [Table 3-1](#), there are two methods to implement a diagnostic safety mechanism for power supply. The first method is to detect voltage or current from the input side. In this method, the diagnostic coverage is low (60%). The other method is to detect the voltage or current from the output side, where the diagnostic coverage is high (99%).

**Table 3-1. Power Supply Safety Mechanism From ISO26262**

Safety Mechanism/Measure	See Overview of Techniques	Typical Diagnostic Considered Achievable	Notes
Voltage or current control (input)	D.2.6.1 <sup>(1)</sup>	Low	–
Voltage or current control (output)	D.2.6.2 <sup>(2)</sup>	High	–

- (1) **Aim:** To detect as soon as possible wrong behavior of input current or voltage values.  
**Description:** Monitoring of output voltage or current.
- (2) **Aim:** To detect as soon as possible wrong behavior of input current or voltage values.  
**Description:** Monitoring of output voltage or current.

For LED power, the TPS552892-Q1 converter system design, which is compliant with ASIL-B design, has two common output detection methods:

- **Using a safety MCU ADC pin to monitor the TPS552892-Q1 output.**

The MCU ADC pin is independent to the TPS552892-Q1 converter output. This means that the diagnostic coverage is relatively high, and it will not add additional BOM cost. From [Figure 3-3](#), you can see the TPS552892-Q1 VOUT pin connected to the MCU ADC pin for output voltage monitoring and a CDC pin connected to a MCU ADC pin for output current monitoring. The TPS552892-Q1 converter senses the output current with ISP/ISN pin and  $\text{IOUT} = (\text{VISP} - \text{VISN}) / \text{R4}$ . The MCU could monitor the CDC pin voltage with ADC to then calculate the buck-boost IOUT. The PG (power good) pin connects to the MCU GPIO pin for power monitoring. The PG acts as an auxiliary safety mechanism can help improve diagnostic coverage. If a TPS552892-Q1 converter over voltage (OV) or under voltage (UV) fault happens, the MCU ADC pin will detect this fault and then cut off (pulling EN pin to low) the TPS552892-Q1 converter output by MCU GPIO, enabling the display to achieve a black screen safe state.

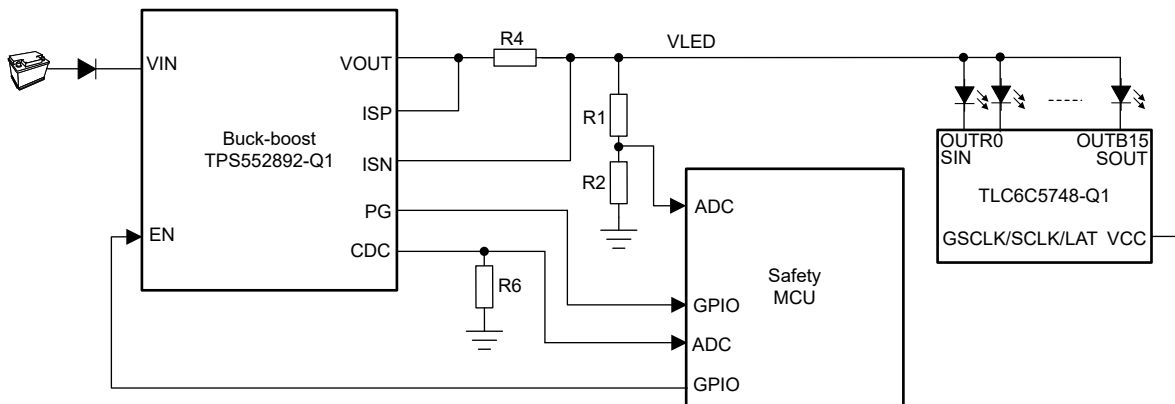

**Figure 3-3. TPS552892-Q1 Output Detection by MCU Mechanism**

- **Using external power supervisor to monitor TPS552892-Q1 output.**

If the display MCU does not have sufficient ADC pins, you can use an external power supervisor to monitor the TPS552892-Q1 converter output OV and UV. The supervisor is independent to the power output, so there is no common cause failure and high performance and accurate detection means that the diagnostic coverage is high.

TI has a variety of voltage supervisors, from monitoring 1 channel to multi channels and supporting input voltage from 5.5V to 65V. For LED power, the  $V_{LED}$  is equal to  $V_F$  (LED forward voltage) and  $V_H$  (LED Driver headroom voltage), with the voltage usually around 6V. In this paper the [TPS37A-Q1](#) high input voltage supervisor is used as an example to achieve voltage monitoring, as shown in [Figure 3-4](#).

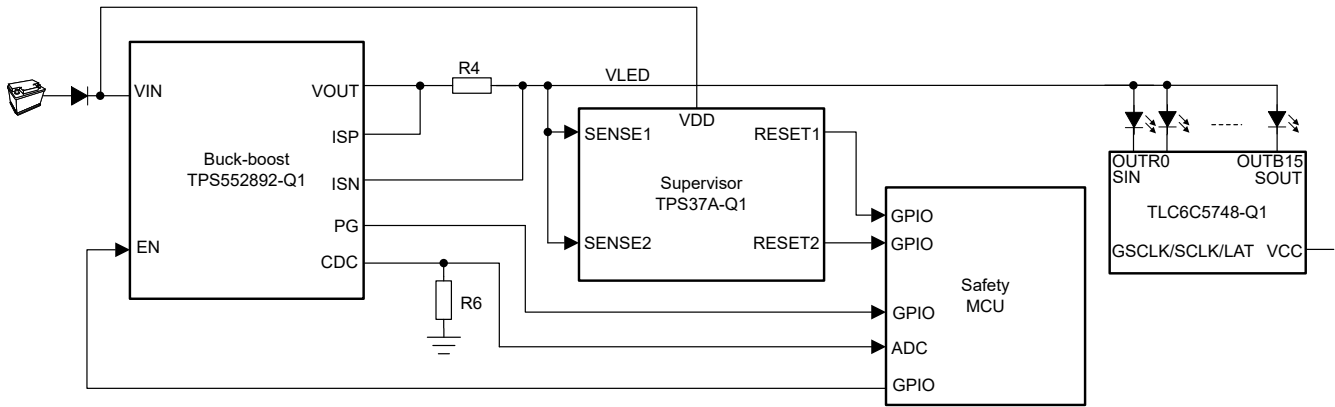

Figure 3-4. TPS552892-Q1 Output Detection by supervisor TPS37A-Q1

TPS552892-Q1: Input 3V~36V, output 6.0V

TPS37A: Acts as safety mechanism to monitor TPS552892-Q1( $V_{LED}$ ) power output. If a TPS552892-Q1 OV (overvoltage > 6.5V) or UV (undervoltage < 5.8V) fault happens, the TPS37A-Q1 detects this using the SENSE1(OV) or the SENSE2(UV) pin and send an alert to the MCU through RESET1(OV) or RESET2(UV) signals. The MCU responds to this signal and performs the corresponding safety action (action depends on the safety goal requirement). For example, to cut off buck-boost output, a black screen is allowed and considered as a safe state.

#### 4 Functional Safety Design for LED Driver

For system-level ASIL-B requirement, vehicle manufacturers usually require that automotive display information is visible. For the local dimming LCD display backlight unit, the LED driver should ideally have the following features:

- Communication interface for device setting and monitoring
- Malfunction detection for each LED channel LED

The TLC6C5748-Q1 driver can meet this requirement. In Figure 4-1, you can see the display controller (TCON) can control and adjust TLC6C5748-Q1 each channel's LED grayscale by SPI interface (SIN, SCLK, LAT, GSCLK) on time, while the TCON can also detect the TLC6C5748-Q1 driver's channel LED malfunctions using the LED open detection (LOD) and LED short detection (LSD) functions through SOUT interface.

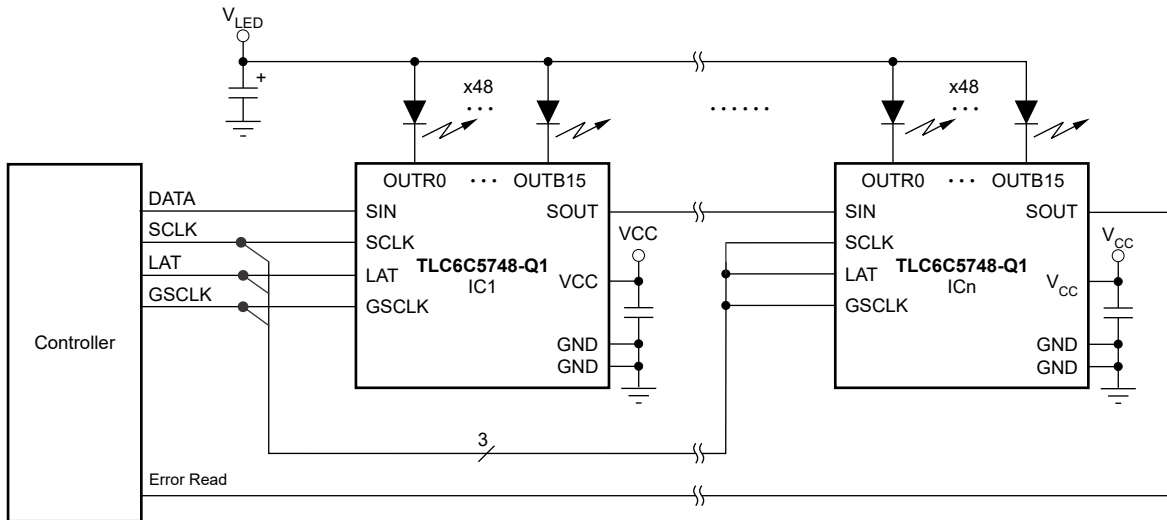
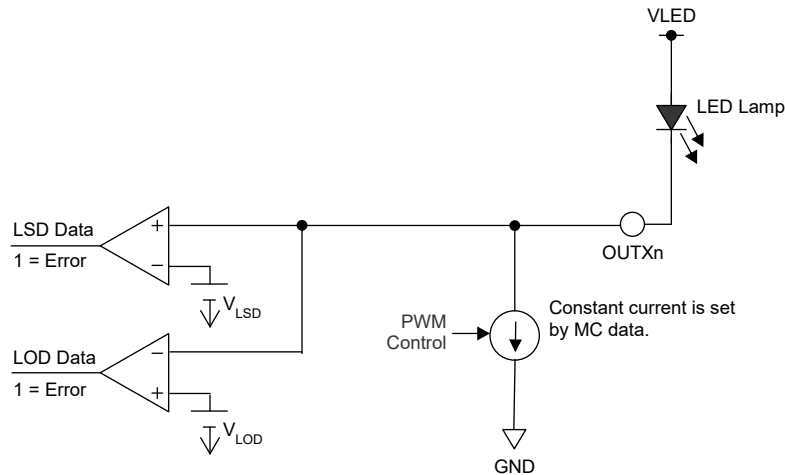

Figure 4-1. Local Dimming Typical Application Daisy-Chainned TLC6C5748-Q1 Devices

The TLC6C5748-Q1 driver has an internal LED open and short detection circuit (LOD and LSD) and truth table is shown in [Figure 4-2](#) and [Table 4-1](#). LOD detects a fault caused by an LED open circuit or a short from OUTXn to ground with low resistance by comparing the OUTXn voltage to the LOD detection threshold voltage (0.3V, typically). LSD data detects a fault caused by a shorted LED between LED terminals by comparing the OUTXn voltage to the LSD detection threshold voltage level set by internal register LSDVLT in device.



**Figure 4-2. TLC6C5748-Q1 LOD and LSD Circuit**

**Table 4-1. TLC6C5748-Q1 LOD and LSD Truth Table**

SID Data	Condition	
	LOD	LSD
0	LED is not opened ( $V_{OUTXn} > V_{LOD}$ )	LED is not shorted ( $V_{OUTXn} > V_{LOD}$ )
1	LED is open or shorted to GND ( $V_{OUTXn} > V_{LOD}$ )	LED is shorted between anode and cathode, or shorted to higher voltage side ( $V_{OUTXn} > V_{LOD}$ )

Detailed safety mechanism as below:

- For LOD, if the OUTXn voltage is lower than the threshold voltage when OUTXn is on, then output LOD bit is set to 1 to indicate an open LED. TCON gets this information from the SPI interface (SOUT) to perform the corresponding safety action (dependent on safety goal requirement). Usually, if a certain percentage of LEDs LOD happens, the TCON stops sending to the GSCLK and alerts the MCU to cut off VCC and VLED, close display backlight and let display into a black screen safe state.
- For LSD, if the OUTXn voltage is higher than the programmed threshold when OUTXn is on, then the corresponding output LSD bit is set to 1 to indicate a shorted LED. TCON gets this information from the SPI interface (SOUT) to perform the corresponding safety action (dependent on safety goal requirement). Usually, if a certain percentage of LEDs LSD happens, the TCON stops sending to the GSCLK and alerts the MCU to cut off VCC and VLED, close display backlight and let display into a black screen safe state.

## 5 Summary

For automotive displays like instrument cluster, head-up display or e-mirror, ASIL-B functional safety is typically mandatory. There are various blocks within the cluster displays that should meet the standards of ASIL-B. In this white paper, we listed methodology for how to design system-level ASIL-B for LED power and LED driver in local dimming backlight unit subsystem. This can also be scaled to other blocks like, including the power module, FPD-Link and MCU subsystems.

## 6 Reference

- Texas Instruments: [TPS552892-Q1 Functional Safety FIT Rate, Failure Mode Distribution and Pin FMA](#)
- Texas Instruments: [TLC6C5748-Q1 Functional Safety FIT Rate, FMD and Pin FMA](#)
- Texas Instruments: [TPS3x-Q1 Functional Safety, FIT Rate, Failure Mode Distribution and Pin FMA](#)

## IMPORTANT NOTICE AND DISCLAIMER

TI PROVIDES TECHNICAL AND RELIABILITY DATA (INCLUDING DATA SHEETS), DESIGN RESOURCES (INCLUDING REFERENCE DESIGNS), APPLICATION OR OTHER DESIGN ADVICE, WEB TOOLS, SAFETY INFORMATION, AND OTHER RESOURCES "AS IS" AND WITH ALL FAULTS, AND DISCLAIMS ALL WARRANTIES, EXPRESS AND IMPLIED, INCLUDING WITHOUT LIMITATION ANY IMPLIED WARRANTIES OF MERCHANTABILITY, FITNESS FOR A PARTICULAR PURPOSE OR NON-INFRINGEMENT OF THIRD PARTY INTELLECTUAL PROPERTY RIGHTS.

These resources are intended for skilled developers designing with TI products. You are solely responsible for (1) selecting the appropriate TI products for your application, (2) designing, validating and testing your application, and (3) ensuring your application meets applicable standards, and any other safety, security, regulatory or other requirements.

These resources are subject to change without notice. TI grants you permission to use these resources only for development of an application that uses the TI products described in the resource. Other reproduction and display of these resources is prohibited. No license is granted to any other TI intellectual property right or to any third party intellectual property right. TI disclaims responsibility for, and you will fully indemnify TI and its representatives against, any claims, damages, costs, losses, and liabilities arising out of your use of these resources.

TI's products are provided subject to [TI's Terms of Sale](#) or other applicable terms available either on [ti.com](https://www.ti.com) or provided in conjunction with such TI products. TI's provision of these resources does not expand or otherwise alter TI's applicable warranties or warranty disclaimers for TI products.

TI objects to and rejects any additional or different terms you may have proposed.

Mailing Address: Texas Instruments, Post Office Box 655303, Dallas, Texas 75265  
Copyright © 2024, Texas Instruments Incorporated