

TPS22999 4.5-V, 1.5-A, 7.5-mΩ On-Resistance Fast Turn-On Load Switch With Regulated Inrush Current

1 Features

- Input operating voltage range (V_{IN}): 0.1 V – 4.5 V
- Bias voltage range: 2.3 V – 5.5 V
- Maximum continuous current: 1.5 A
- ON-resistance (R_{ON}): 7.5 mΩ (typical)
- Regulated inrush current
- Integrated quick output discharge: 5.3 Ω
- Open drain Power-Good (\overline{PG}) signal
- Turn-on time: < 200 μs at $V_{IN} = 1.0$ V
- Thermal shutdown
- VBIAS undervoltage lockout (UVLO)
- Low power consumption:
 - ON state (I_Q): 10 μA (typical)
 - OFF state (I_{SD}): 2.7 μA (typical)
- Smart EN pin pulldown ($R_{PD,EN}$)
 - $EN \geq V_{IH}$ (I_{ON}): 25 nA (typical)
 - $EN \leq V_{IL}$ ($R_{PD,ON}$): 500 kΩ (typical)

2 Applications

- Wearables
- Solid state drive
- PC and notebooks
- Industrial PC
- Optical module

3 Description

The TPS22999 is a single-channel load switch that is designed to achieve a fast turn-on time while keeping a low inrush current. The device contains an N-channel MOSFET that can operate over an input voltage range of 0.1 V to $V_{BIAS} - 1.0$ V and can support a maximum continuous current of 1.5 A.

The switch is controlled by an enable pin (EN), which is capable of interfacing directly with low voltage GPIO signals ($V_{IH} = 0.8$ V). The TPS22999 device has an integrated 5.3-Ω quick output discharge path when the switch is turned off to enable reliable system operation. There is a Power-Good (\overline{PG}) signal on the device that indicates when the main MOSFET has fully settled to the lowest resistance path, which can be used to enable a downstream load. Integrated thermal shutdown makes sure of protection in high temperature environments.

The TPS22999 is available in a 0.35 mm pitch, 8-pin WCSP package (YCH) and is characterized for operation over the free-air temperature range of -40°C to $+105^{\circ}\text{C}$.

Package Information

PART NUMBER	PACKAGE ⁽¹⁾	PACKAGE SIZE ⁽²⁾
TPS22999	YCH (DSBGA, 8)	1.4 mm × 0.7 mm

(1) For more information, see [Section 10](#).

(2) The package size (length × width) is a nominal value and includes pins, where applicable.

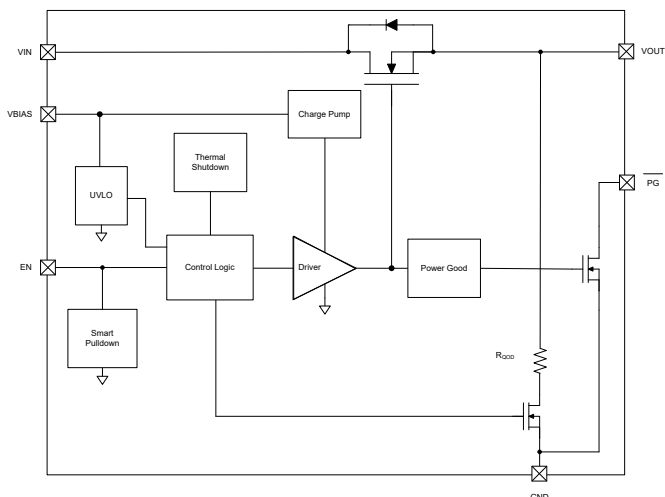

TPS22999 Block Diagram

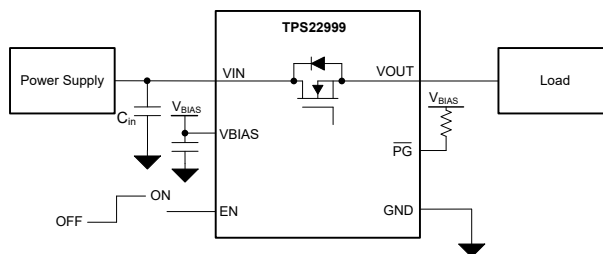

TPS22999 Typical Application



Table of Contents

1 Features	1	6.2 Functional Block Diagram.....	12
2 Applications	1	6.3 Feature Description.....	12
3 Description	1	6.4 Device Functional Modes.....	14
4 Pin Configuration and Functions	3	7 Application and Implementation	15
5 Specifications	4	7.1 Application Information.....	15
5.1 Absolute Maximum Ratings.....	4	7.2 Typical Application.....	15
5.2 ESD Ratings.....	4	7.3 Power Supply Recommendations.....	16
5.3 Recommended Operating Conditions.....	4	7.4 Layout.....	16
5.4 Thermal Information.....	5	8 Device and Documentation Support	18
5.5 Electrical Characteristics (VBIAS = 5.5 V).....	5	8.1 Receiving Notification of Documentation Updates....	18
5.6 Electrical Characteristics (VBIAS = 3.4 V).....	6	8.2 Support Resources.....	18
5.7 Electrical Characteristics (VBIAS = 2.3 V).....	7	8.3 Trademarks.....	18
5.8 Switching Characteristics.....	8	8.4 Electrostatic Discharge Caution.....	18
5.9 Timing Diagrams	10	8.5 Glossary.....	18
5.10 Typical Characteristics.....	11	9 Revision History	18
6 Detailed Description	12	10 Mechanical, Packaging, and Orderable Information	19
6.1 Overview.....	12		

4 Pin Configuration and Functions

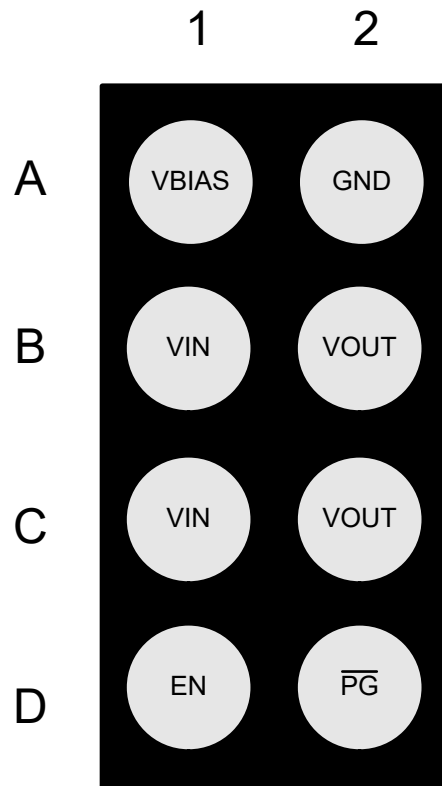

Figure 4-1. TPS22999 YCH Package, 8-Pin DSBGA (Top View)

Table 4-1. Pin Functions

PIN		TYPE ⁽¹⁾	DESCRIPTION
NAME	NO.		
VBIAS	A1	I	Device bias supply. Connect a 0.1-μF capacitor to ground.
GND	A2	—	Device ground
VIN	B1, C1	I	Switch input
VOUT	B2, C2	O	Switch output
EN	D1	I	Switch enable
$\overline{\text{PG}}$	D2	O	Open drain power-good signal, asserted low when the MOSFET has been fully enhanced. Connect to ground if unused.

(1) I = input, O = output

5 Specifications

5.1 Absolute Maximum Ratings

over operating free-air temperature range (unless otherwise noted)⁽¹⁾

		MIN	MAX	UNIT
V _{IN}	Input voltage	-0.3	6	V
V _{OUT}	Output voltage	-0.3	V _{IN} + 0.3	V
V _{BIAS}	Bias voltage	-0.3	6	V
V _{EN} , V _{PG}	Control pin voltage	-0.3	6	V
I _{MAX}	Maximum current		1.5	A
I _{MAX_PLS}	Maximum current (24 hours)		4.5	A
T _J	Junction temperature		Internally Limited	°C
T _{stg}	Storage temperature	-65	150	°C

- (1) Operation outside the Absolute Maximum Ratings may cause permanent device damage. Absolute Maximum Ratings do not imply functional operation of the device at these or any other conditions beyond those listed under Recommended Operating Conditions. If used outside the Recommended Operating Conditions but within the Absolute Maximum Ratings, the device may not be fully functional, and this may affect device reliability, functionality, performance, and shorten the device lifetime.

5.2 ESD Ratings

			VALUE	UNIT
V _(ESD)	Electrostatic discharge	Human body model (HBM), per ANSI/ESDA/ JEDEC JS-001, all pins ⁽¹⁾	±2000	V
		Charged device model (CDM), per JEDEC specification JS-002, all pins ⁽²⁾	±500	

- (1) JEDEC document JEP155 states that 500-V HBM allows safe manufacturing with a standard ESD control process.
 (2) JEDEC document JEP157 states that 250-V CDM allows safe manufacturing with a standard ESD control process.

5.3 Recommended Operating Conditions

over operating free-air temperature range (unless otherwise noted)

		MIN	NOM	MAX	UNIT
V _{IN}	Input voltage	0.1		V _{BIAS} - 1.0	V
V _{OUT}	Output voltage, EN > V _{IH}	0.1		V _{IN}	V
V _{BIAS}	Bias voltage	2.3		5.5	V
V _{IH}	EN pin high voltage range	0.8		5.5	V
V _{IL}	EN pin low voltage range	0		0.35	V
C _{OUT}	Output capacitor ⁽¹⁾	0		70	μF
V _{PG}	PG pin voltage	0		5.5	V
T _A	Ambient temperature	-40		105	°C

- (1) Effective output capacitance required for stability

5.4 Thermal Information

THERMAL METRIC ^{(1) (2)}		TPS22999	UNIT
		YCH (DSBGA)	
		8 PINS	
$R_{\theta JA}$	Junction-to-ambient thermal resistance	121.8	°C/W
$R_{\theta JC(top)}$	Junction-to-case (top) thermal resistance	1	°C/W
$R_{\theta JB}$	Junction-to-board thermal resistance	34.2	°C/W
Ψ_{JT}	Junction-to-top characterization parameter	0.4	°C/W
Y_{JB}	Junction-to-board characterization parameter	34.2	°C/W
$R_{\theta JC(bot)}$	Junction-to-case (bottom) thermal resistance	N/A	°C/W

- (1) For more information about traditional and new thermal metrics, see the [Semiconductor and IC Package Thermal Metrics](#) application report.
- (2) The thermal parameters are based on a 4-layer PCB according to the JESD51-5 and JESD51-7 standards.

5.5 Electrical Characteristics (VBIAS = 5.5 V)

over operating free-air temperature range (unless otherwise noted)

PARAMETER		TEST CONDITIONS	T_A	MIN	TYP	MAX	UNIT
Power Consumption							
$I_{SD,VBIAS}$	VBIAS shutdown current	EN = 0 V	25°C	2.7			μA
			-40°C to 85°C			4	μA
			-40°C to 105°C			5	μA
$I_{Q,VBIAS}$	VBIAS quiescent current	EN > V_{IH}	25°C	10			μA
			-40°C to 85°C			18	μA
			-40°C to 105°C			20	μA
$I_{Q,VIN}$	VIN quiescent current	EN > V_{IH}	25°C	0.1			μA
			-40°C to 85°C			1	μA
			-40°C to 105°C			1.5	μA
$I_{SD,VIN}$	VIN shutdown current	EN = 0 V, V_{IN} = 4.5 V	25°C	0.1			μA
			-40°C to 85°C			1	μA
			-40°C to 105°C			3	μA
I_{EN}	EN pin leakage	EN = VBIAS	-40°C to 105°C	0.1			μA
Performance							

5.5 Electrical Characteristics (VBIAS = 5.5 V) (continued)

over operating free-air temperature range (unless otherwise noted)

PARAMETER		TEST CONDITIONS	T _A	MIN	TYP	MAX	UNIT
R _{ON}	On-resistance	VIN = 4.5 V	25°C	7.5			mΩ
			–40°C to 85°C			12	mΩ
			–40°C to 105°C			15	mΩ
		VIN = 3.3 V	25°C	7.5			mΩ
			–40°C to 85°C			12	mΩ
			–40°C to 105°C			15	mΩ
		VIN = 1.8 V	25°C	7.5			mΩ
			–40°C to 85°C			12	mΩ
			–40°C to 105°C			15	mΩ
		VIN = 1.0 V	25°C	7.5			mΩ
			–40°C to 85°C			12	mΩ
			–40°C to 105°C			15	mΩ
VIN = 0.78 V	25°C	7.5			mΩ		
	–40°C to 85°C			12	mΩ		
	–40°C to 105°C			15	mΩ		
VIN = 0.5 V	25°C	7.5			mΩ		
	–40°C to 85°C			12	mΩ		
	–40°C to 105°C			15	mΩ		
V _{OL,PG}	Power-Good VOL	I _{PG} = 500uA	–40°C to 105°C			0.2	V
V _{BIAS_UVLO}	V _{BIAS} undervoltage lockout	Falling	–40°C to 105°C	1.65	1.85	2.05	V
		Hysteresis	–40°C to 105°C	0.150			V
		Rising	–40°C to 105°C	1.8	2.0	2.2	V
I _{INRUSH}	Regulated inrush current	C _L = 60uF, V _{IN} ≤ 1 V	–40°C to 105°C		0.95	1.33	A
		C _L = 60uF, V _{IN} > 1 V	–40°C to 105°C		0.95	1.4	A
V _{HYS,EN}	Enable pin hysteresis	VIN = 4.5 V	–40°C to 105°C		75		mV
R _{PD,EN}	Smart pulldown Resistance	EN < V _{IL}	25°C	500			kΩ
			–40°C to 105°C			750	kΩ
R _{QOD}	QOD resistance	VIN = 1.0 V	25°C	5.3			Ω
			–40°C to 105°C			10	Ω
Protection							
TSD	Thermal shutdown		-	116	131	146	°C

5.6 Electrical Characteristics (VBIAS = 3.4 V)

over operating free-air temperature range (unless otherwise noted).

PARAMETER		TEST CONDITIONS	T _A	MIN	TYP	MAX	UNIT
Power Consumption							
I _{SD,VBIAS}	VBIAS shutdown current	EN = 0 V	25°C	2.2			μA
			–40°C to 85°C			4	μA
			–40°C to 105°C			5	μA

5.6 Electrical Characteristics (VBIAS = 3.4 V) (continued)

over operating free-air temperature range (unless otherwise noted).

PARAMETER		TEST CONDITIONS	T _A	MIN	TYP	MAX	UNIT		
I _{Q,VBIAS}	VBIAS quiescent current	EN > V _{IH}	25°C	10			μA		
			-40°C to 85°C			18	μA		
			-40°C to 105°C			20	μA		
I _{Q,VIN}	VIN quiescent current	EN > V _{IH}	25°C	0.1			μA		
			-40°C to 85°C			1	μA		
			-40°C to 105°C			1.5	μA		
I _{SD,VIN}	VIN shutdown current	EN = 0 V, V _{IN} = 2.4 V	25°C	0.1			μA		
			-40°C to 85°C			1	μA		
			-40°C to 105°C			2	μA		
I _{EN}	EN pin leakage	EN = VBIAS	-40°C to 105°C	0.1			μA		
Performance									
R _{ON}	On-resistance	VIN = 2.4 V	25°C	7.5			mΩ		
			-40°C to 85°C			12	mΩ		
			-40°C to 105°C			15	mΩ		
		VIN = 1.8 V	25°C	7.5			mΩ		
			-40°C to 85°C			12	mΩ		
			-40°C to 105°C			15	mΩ		
		VIN = 1.0 V	25°C	7.5			mΩ		
			-40°C to 85°C			12	mΩ		
			-40°C to 105°C			15	mΩ		
		VIN = 0.78 V	25°C	7.5			mΩ		
			-40°C to 85°C			12	mΩ		
			-40°C to 105°C			15	mΩ		
		VIN = 0.5 V	25°C	7.5			mΩ		
			-40°C to 85°C			12	mΩ		
			-40°C to 105°C			15	mΩ		
		I _{INRUSH}	Regulated inrush current	C _L = 60 μF, V _{IN} ≤ 1 V	-40°C to 105°C	0.95	1.33		A
				C _L = 60 μF, V _{IN} > 1 V	-40°C to 105°C	0.95	1.4		A
		V _{OL,PG}	Power-Good V _{OL}	I _{PG} = 500 μA	-40°C to 105°C	0.2			V
V _{HYS,EN}	Enable pin hysteresis	VIN = 2.4 V	-40°C to 105°C	75			mV		
R _{PD,EN}	Smart pulldown resistance	EN < V _{IL}	25°C	500			kΩ		
			-40°C to 105°C			750	kΩ		
R _{QOD}	QOD resistance	VIN = 1.0 V	25°C	8.3			Ω		
			-40°C to 105°C			19	Ω		
Protection									

5.7 Electrical Characteristics (VBIAS = 2.3 V)

over operating free-air temperature range (unless otherwise noted)

PARAMETER	TEST CONDITIONS	T _A	MIN	TYP	MAX	UNIT
Power Consumption						

5.7 Electrical Characteristics (VBIAS = 2.3 V) (continued)

over operating free-air temperature range (unless otherwise noted)

PARAMETER		TEST CONDITIONS	T _A	MIN	TYP	MAX	UNIT
I _{SD,VBIAS}	VBIAS shutdown current	EN = 0 V	25°C	2.1			μA
			-40°C to 85°C			3.5	μA
			-40°C to 105°C			4	μA
I _{Q,VBIAS}	VBIAS quiescent current	EN > V _{IH}	25°C	7.5			μA
			-40°C to 85°C			18	μA
			-40°C to 105°C			20	μA
I _{Q,VIN}	VIN quiescent current	EN > V _{IH}	25°C	0.1			μA
			-40°C to 85°C			1	μA
			-40°C to 105°C			1.5	μA
I _{SD,VIN}	VIN shutdown current	EN = 0 V, V _{IN} = 1.3 V	25°C	0.1			μA
			-40°C to 85°C			1	μA
			-40°C to 105°C			2	μA
I _{EN}	EN pin leakage	EN = VBIAS	-40°C to 105°C	0.1			μA
Performance							
R _{ON}	On-resistance	VIN = 1.3 V	25°C	7.5			mΩ
			-40°C to 85°C			12	mΩ
			-40°C to 105°C			15	mΩ
		VIN = 1.0 V	25°C	7.5			mΩ
			-40°C to 85°C			12	mΩ
			-40°C to 105°C			15	mΩ
		VIN = 0.78 V	25°C	7.5			mΩ
			-40°C to 85°C			12	mΩ
			-40°C to 105°C			15	mΩ
		VIN = 0.5 V	25°C	7.5			mΩ
			-40°C to 85°C			12	mΩ
			-40°C to 105°C			15	mΩ
I _{INRUSH}	Regulated inrush current	C _L = 60 μF	-40°C to 105°C	0.9	1.33		A
V _{OL,PG}	Power-Good VOL	I _{PG} = 500 μA	-40°C to 105°C			0.2	V
V _{HYS,EN}	Enable pin hysteresis	VIN = 1.3 V	-40°C to 105°C	75			mV
R _{PD,EN}	Smart pulldown Resistance	EN < V _{IL}	25°C	500			kΩ
			-40°C to 105°C			750	kΩ
R _{QOD}	QOD resistance	VIN = 1.0 V	25°C	16			Ω
			-40°C to 105°C			35	Ω
Protection							
TSD	Thermal shutdown		-	116	131	146	°C

5.8 Switching Characteristics

 over operating free-air temperature range (unless otherwise noted). Measured 350 μs after V_{bias} > 2.3 V.

PARAMETER		TEST CONDITIONS	MIN	TYP	MAX	UNIT
VIN = 4.5 V						
t _{ON}	Turn ON time	R _L = 100 Ω, C _L = 60 μF			440	μs
t _{RISE}	Rise time	R _L = 100 Ω, C _L = 60 μF	200			μs
t _D	Delay time	R _L = 100 Ω, C _L = 60 μF	40			μs

5.8 Switching Characteristics (continued)

over operating free-air temperature range (unless otherwise noted). Measured 350 μ s after $V_{bias} > 2.3$ V.

PARAMETER		TEST CONDITIONS	MIN	TYP	MAX	UNIT
tFALL	Fall time	$R_L = 100 \Omega, C_L = 60 \mu F$		850		μ s
tOFF	Turn OFF time	$R_L = 100 \Omega, C_L = 60 \mu F$			5	μ s
VIN = 3.3 V						
tON	Turn ON time	$R_L = 100 \Omega, C_L = 60 \mu F$			365	μ s
tRISE	Rise time	$R_L = 100 \Omega, C_L = 60 \mu F$		170		μ s
tD	Delay time	$R_L = 100 \Omega, C_L = 60 \mu F$		30		μ s
tFALL	Fall time	$R_L = 100 \Omega, C_L = 60 \mu F$		750		μ s
tOFF	Turn OFF time	$R_L = 100 \Omega, C_L = 60 \mu F$			5	μ s
VIN = 1.8 V						
tON	Turn ON time	$R_L = 100 \Omega, C_L = 60 \mu F$			255	μ s
tRISE	Rise time	$R_L = 100 \Omega, C_L = 60 \mu F$		95		μ s
tD	Delay time	$R_L = 100 \Omega, C_L = 60 \mu F$		30		μ s
tFALL	Fall time	$R_L = 100 \Omega, C_L = 60 \mu F$		900		μ s
tOFF	Turn OFF time	$R_L = 100 \Omega, C_L = 60 \mu F$			5	μ s
VIN = 1.0 V						
tON	Turn ON time	$R_L = 100 \Omega, C_L = 60 \mu F$			200	μ s
tRISE	Rise time	$R_L = 100 \Omega, C_L = 60 \mu F$		60		μ s
tD	Delay time	$R_L = 100 \Omega, C_L = 60 \mu F$		27		μ s
tFALL	Fall time	$R_L = 100 \Omega, C_L = 60 \mu F$		800		μ s
tOFF	Turn OFF time	$R_L = 100 \Omega, C_L = 60 \mu F$			5	μ s
VIN = 0.78 V						
tON	Turn ON time	$R_L = 100 \Omega, C_L = 60 \mu F$			182	μ s
tRISE	Rise time	$R_L = 100 \Omega, C_L = 60 \mu F$		40		μ s
tD	Delay time	$R_L = 100 \Omega, C_L = 60 \mu F$		30		μ s
tFALL	Fall time	$R_L = 100 \Omega, C_L = 60 \mu F$		780		μ s
tOFF	Turn OFF time	$R_L = 100 \Omega, C_L = 60 \mu F$			5	μ s
VIN = 0.5 V						
tON	Turn ON time	$R_L = 100 \Omega, C_L = 60 \mu F$			170	μ s
tRISE	Rise time	$R_L = 100 \Omega, C_L = 60 \mu F$		30		μ s
tD	Delay time	$R_L = 100 \Omega, C_L = 60 \mu F$		27		μ s
tFALL	Fall time	$R_L = 100 \Omega, C_L = 60 \mu F$		750		μ s
tOFF	Turn OFF time	$R_L = 100 \Omega, C_L = 60 \mu F$			5	μ s

5.9 Timing Diagrams

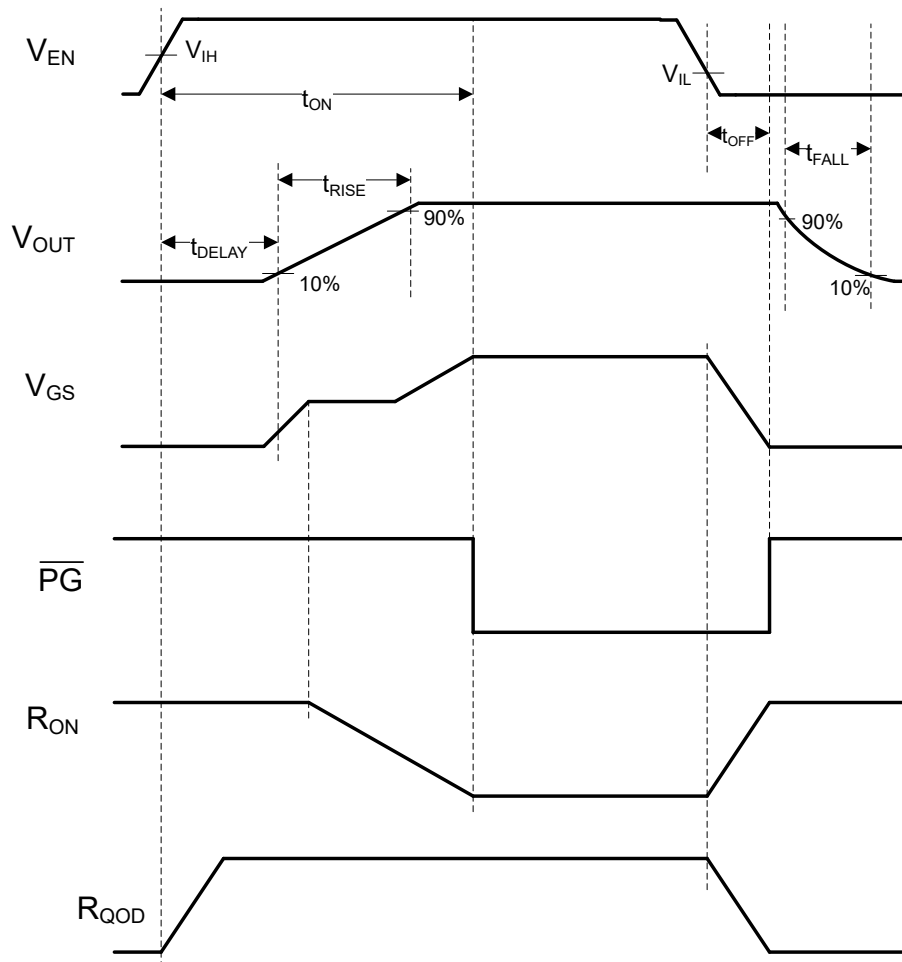

Figure 5-1. TPS22999 Timing Diagram

5.10 Typical Characteristics

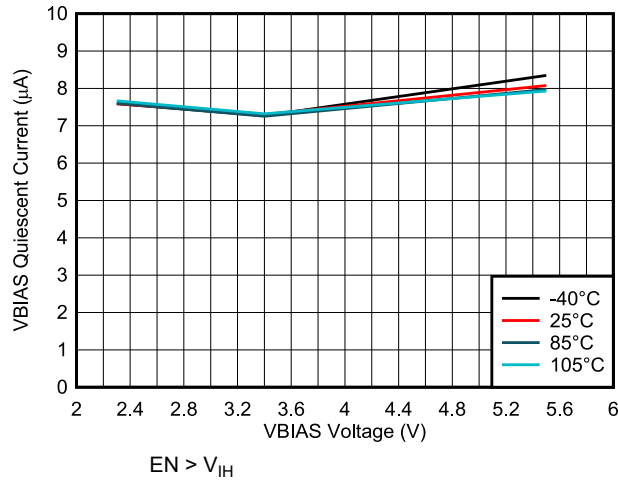

Figure 5-2. VBIAS Quiescent Current vs VBIAS Voltage

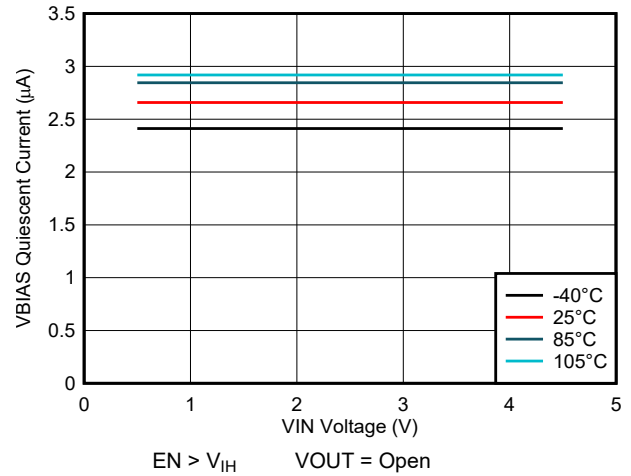

Figure 5-3. VBIAS Quiescent Current vs VIN Voltage

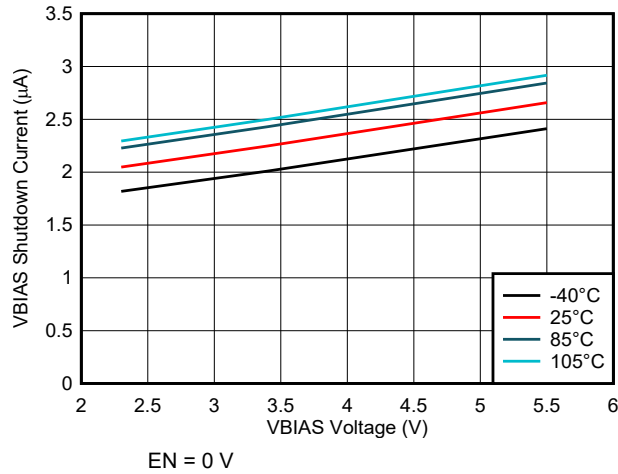

Figure 5-4. VBIAS Shutdown Current vs VBIAS Voltage

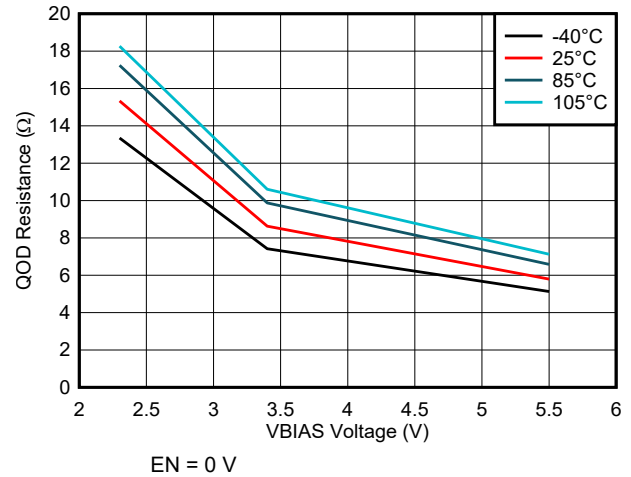

Figure 5-5. QOD Resistance vs VBIAS Voltage

6 Detailed Description

6.1 Overview

The TPS22999 device is a single-channel load switch with a 7.5-mΩ power MOSFET designed to operate up to 1.5 A. The voltage range is 0.1 V to 4.5 V. The device regulates inrush current upon turn-on while providing a fast turn-on time.

The switch is controlled by an enable pin (EN), which is capable of interfacing directly with low voltage GPIO signals down to the V_{IH} level of 0.8 V. The TPS22999 device has an integrated 10-Ω quick output discharge when switch is turned off. There is a Power-Good (\overline{PG}) signal on the device that indicates when the main MOSFET is fully turned on and the on-resistance is at final value.

6.2 Functional Block Diagram

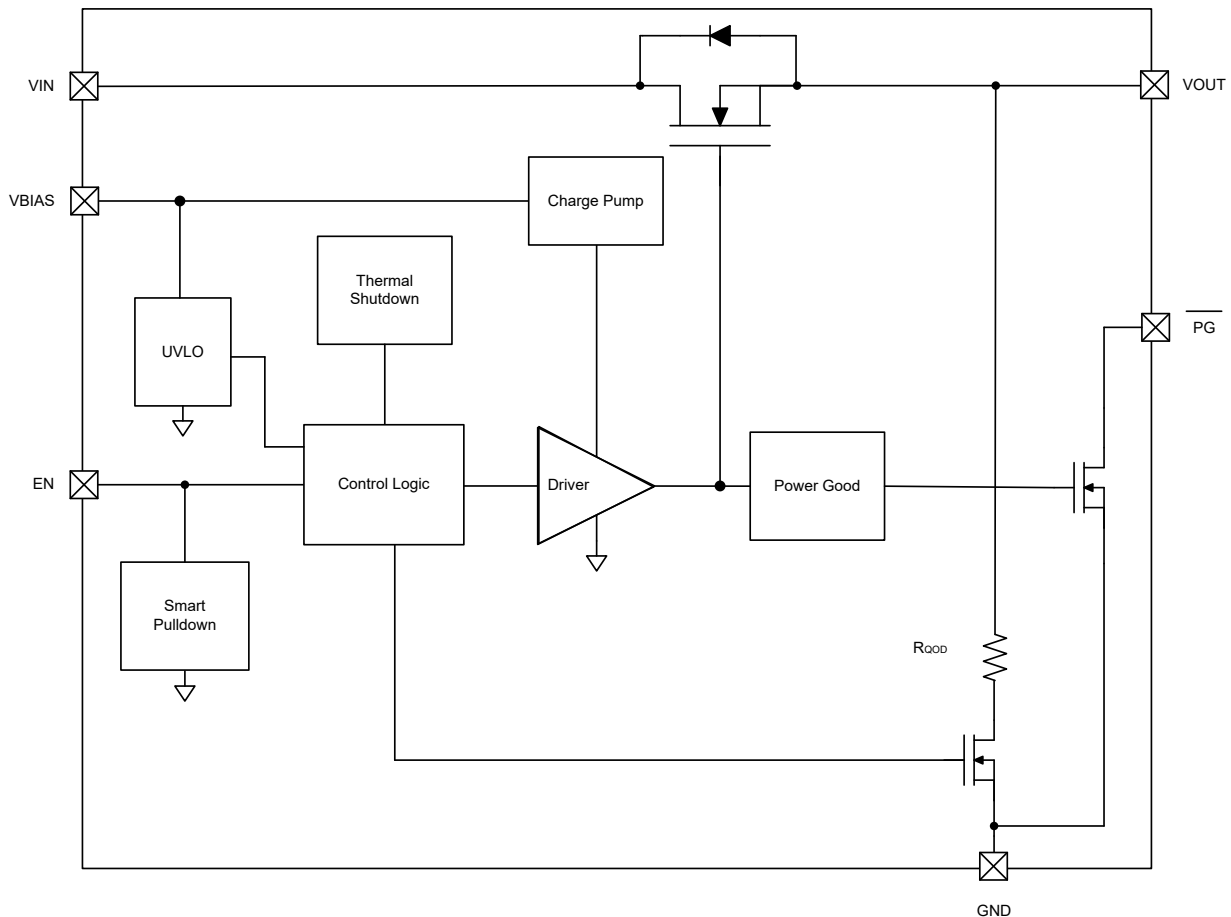

6.3 Feature Description

6.3.1 ON and OFF Control

The EN pin controls the state of the switch. The EN pin is compatible with standard GPIO logic threshold so the EN pin can be used in a wide variety of applications. When power is first applied to VIN, a Smart Pulldown is used to keep the EN pin from floating until the system sequencing is complete. After the EN pin is deliberately driven high ($\geq V_{IH}$), the Smart Pulldown is disconnected to prevent unnecessary power loss. See the following table for when the EN Pin Smart Pulldown is active.

EN Pin Voltage	EN Pin Function
$\leq V_{IL}$	Pulldown active
$\geq V_{IH}$	No pulldown

6.3.2 Regulated Inrush Current

Depending on the rise time at power-up, output load capacitances can cause large inrush currents that are limited only by parasitic resistance and inductances present in wiring and interconnections. These high currents can cause input voltage supply droop which can harm or cause malfunction in other circuits in the system.

To prevent these problems, TPS22999 regulates the inrush current (I_{INRUSH}) to a 1-A typical during the turn-on phase. This regulation enables the system to operate reliably while maintaining a fast turn-on time.

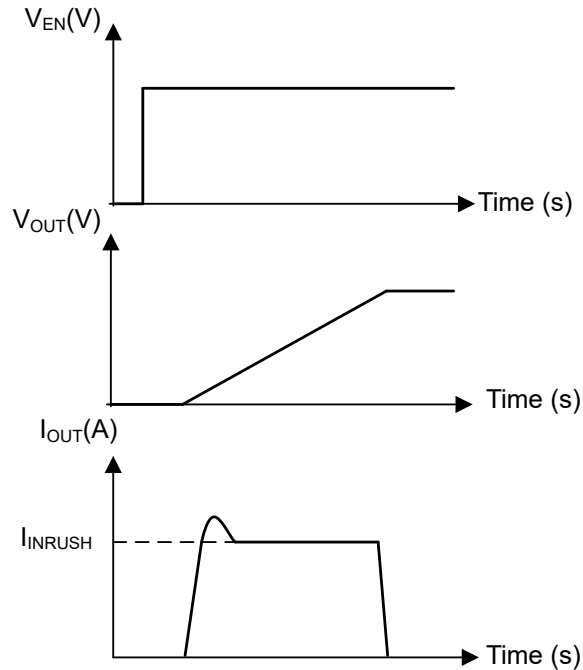

Figure 6-1. Regulated Inrush Current Behavior

6.3.3 Integrated Quick Output Discharge

TPS22999 integrates Quick Output Discharge (QOD). When the switch is disabled, a discharge resistor is connected between V_{OUT} and GND. This resistor has a typical value of 10 Ω and prevents the output from floating while the switch is disabled while helping safely discharge output capacitances to ground.

6.3.4 Thermal Shutdown

When the device temperature reaches 131°C (typical), the device latches itself off to prevent thermal damage. The \overline{PG} pin is deasserted to signal the output has been latched off. While T_J is over the T_{ABS} threshold, the output remains disabled even if the EN pin is toggled. After T_J decreases below the T_{ABS} threshold, the device does not enable the channel until the EN pin is toggled.

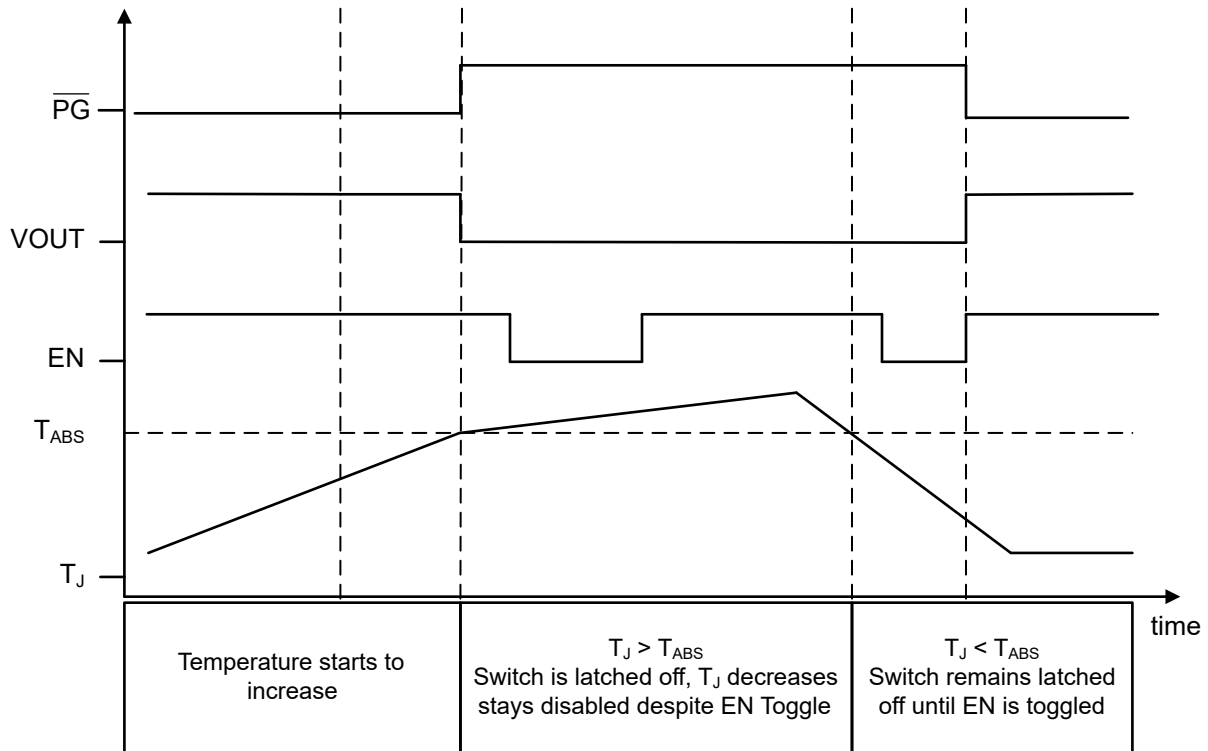

Figure 6-2. Thermal Shutdown Behavior

6.3.5 Power-Good (PG) Signal

The TPS22999 device has a Power-Good (\overline{PG}) output signal to indicate the gate of the pass FET is driven high and the switch is on with the on-resistance close to final value (full load ready). The signal is an active low and open drain output which can be connected to a voltage source through an external pullup resistor, R_{PU} . This voltage source can be V_{OUT} from the TPS22999 device or another external voltage. V_{BIAS} is required for \overline{PG} to have a valid output.

6.4 Device Functional Modes

The following table summarizes the device functional modes:

EN	Fault Condition	VOUT State	nPG
L	N/A	Hi-Z	Hi-Z
H	None	V_{IN} (through R_{ON})	LO
X	Thermal shutdown	Hi-Z	Hi-Z

7 Application and Implementation

Note

Information in the following applications sections is not part of the TI component specification, and TI does not warrant its accuracy or completeness. TI's customers are responsible for determining suitability of components for their purposes, as well as validating and testing their design implementation to confirm system functionality.

7.1 Application Information

This section highlights some of the design considerations when implementing this device in various applications.

7.2 Typical Application

This typical application demonstrates how to use the TPS22999 device to limit start-up inrush current.

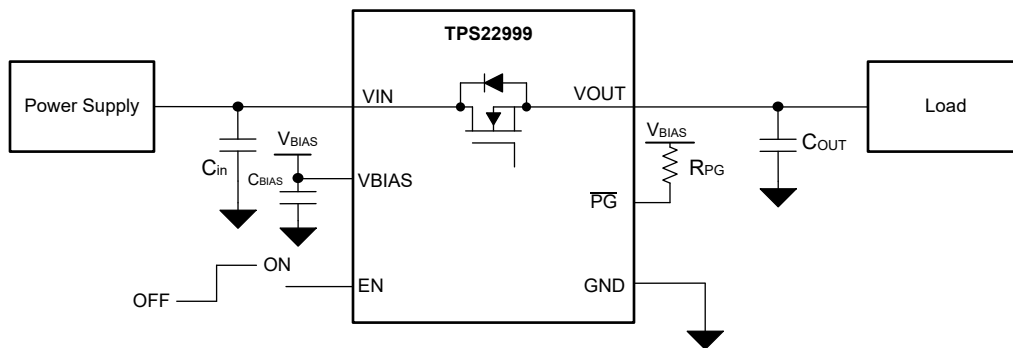

Figure 7-1. TPS22999 Basic Application

Table 7-1. Component Descriptions

DESIGN PARAMETER	TYPICAL VALUES	DESCRIPTION
C_{IN}	1 μ F	Filtering voltage transients
C_{OUT}	100 nF	Filtering voltage transients
C_{BIAS}	0.1 μ F	Filtering voltage transients and noises
R_{PG}	10 k Ω	Pullup resistor for the open-drain output

7.2.1 Design Requirements

For this example, the values below are used as the design parameters.

Table 7-2. Design Parameters

PARAMETER	VALUE
V_{BIAS}	3.4 V
V_{IN}	1.8 V
Load capacitance	60 μ F
Inrush current	1 A

7.2.2 Detailed Design Procedure

When the switch is enabled, the switch charges up the output capacitance from 0 V to the set value (1.8 V in this example). This charge arrives in the form of inrush current. As the inrush current is controlled by the device, the time to fully charge up a capacitor can be calculated with the following formula:

$$t_{\text{charge}} = V_{\text{IN}} / I_{\text{inrush}} \times C_{\text{L}}$$

where:

- C_{L} is the output capacitance.
- I_{inrush} is the inrush current limited internally by the device
- V_{IN} is the input voltage

The TPS22999 offers an internally set inrush current limit (0.9-A typical with 3.4-V V_{BIAS}), which allows the customer to calculate the time to fully charge up a load capacitance.

$$t_{\text{charge}} = 1.8 \text{ V} / 0.9 \text{ A} \times 60 \text{ } \mu\text{F} \tag{1}$$

$$t_{\text{charge}} = 130 \text{ } \mu\text{s} \tag{2}$$

With TPS22999, the time to charge up a 60- μF capacitor to 1.8-V V_{IN} voltage is 130- μs typical at 3.4-V V_{BIAS} voltage.

7.3 Power Supply Recommendations

The TPS22999 device is designed to operate with a V_{IN} range of 0.1 V to $V_{\text{BIAS}} - 1$ V. Regulate the V_{IN} power supply well and place as close to the device terminal as possible. The power supply must be able to withstand all transient load current steps. In most situations, using an input capacitance (C_{IN}) of 1 μF is sufficient to prevent the supply voltage from dipping when the switch is turned on. In cases where the power supply is slow to respond to a large transient current or large load current step, additional bulk capacitance can be required on the input. TI recommends to connect a 0.1- μF capacitance to V_{BIAS} .

7.4 Layout

7.4.1 Layout Guidelines

For best performance, all traces must be as short as possible. To be most effective, place the input and output capacitors close to the device to minimize the effects that parasitic trace inductances can have on normal operation. Using wide traces for V_{IN} , V_{OUT} , and GND helps minimize the parasitic electrical effects.

7.4.2 Layout Example

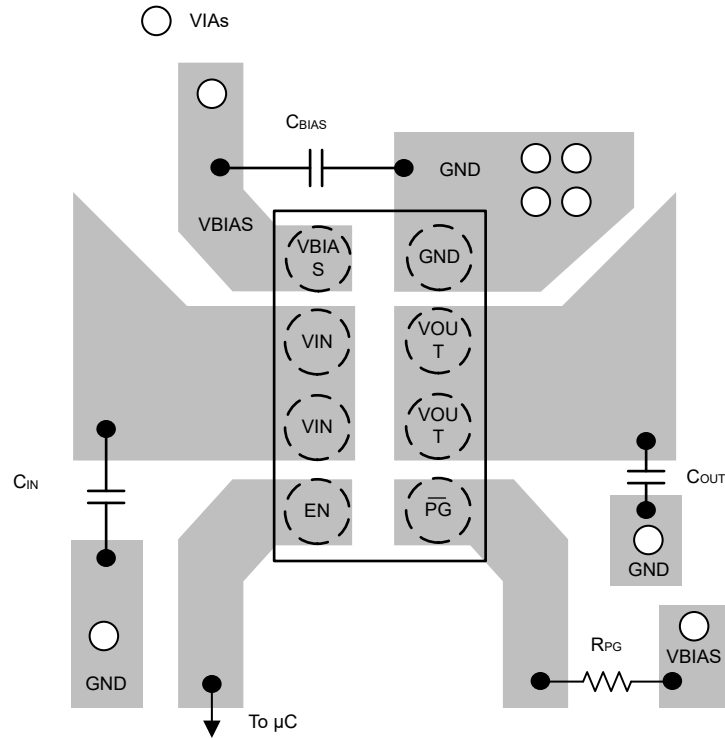

Figure 7-2. TPS22999 Layout Example

8 Device and Documentation Support

8.1 Receiving Notification of Documentation Updates

To receive notification of documentation updates, navigate to the device product folder on ti.com. Click on *Notifications* to register and receive a weekly digest of any product information that has changed. For change details, review the revision history included in any revised document.

8.2 Support Resources

TI E2E™ [support forums](#) are an engineer's go-to source for fast, verified answers and design help — straight from the experts. Search existing answers or ask your own question to get the quick design help you need.

Linked content is provided "AS IS" by the respective contributors. They do not constitute TI specifications and do not necessarily reflect TI's views; see TI's [Terms of Use](#).

8.3 Trademarks

TI E2E™ is a trademark of Texas Instruments.
All trademarks are the property of their respective owners.

8.4 Electrostatic Discharge Caution



This integrated circuit can be damaged by ESD. Texas Instruments recommends that all integrated circuits be handled with appropriate precautions. Failure to observe proper handling and installation procedures can cause damage.

ESD damage can range from subtle performance degradation to complete device failure. Precision integrated circuits may be more susceptible to damage because very small parametric changes could cause the device not to meet its published specifications.

8.5 Glossary

[TI Glossary](#) This glossary lists and explains terms, acronyms, and definitions.

9 Revision History

NOTE: Page numbers for previous revisions may differ from page numbers in the current version.

Changes from Revision * (September 2023) to Revision A (November 2023)	Page
• Changed document status from "Advance Information" to "Production Data".....	1

10 Mechanical, Packaging, and Orderable Information

The following pages include mechanical, packaging, and orderable information. This information is the most current data available for the designated devices. This data is subject to change without notice and revision of this document. For browser-based versions of this data sheet, refer to the left-hand navigation.

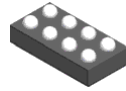

YCH0008-C01

PACKAGE OUTLINE

DSBGA - 0.4 mm max height

DIE SIZE BALL GRID ARRAY

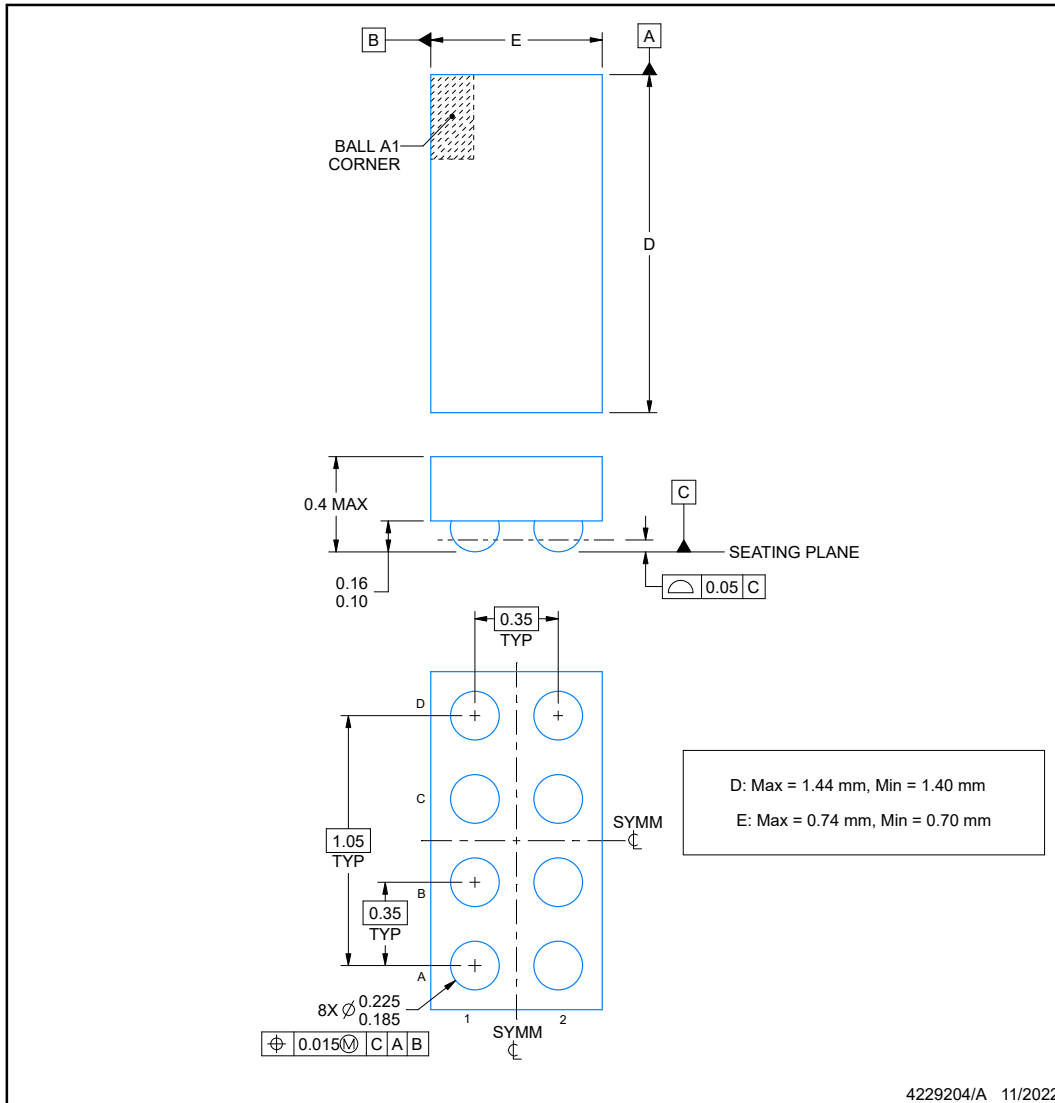

NOTES:

1. All linear dimensions are in millimeters. Any dimensions in parenthesis are for reference only. Dimensioning and tolerancing per ASME Y14.5M.
2. This drawing is subject to change without notice.

EXAMPLE STENCIL DESIGN

YCH0008-C01

DSBGA - 0.4 mm max height

DIE SIZE BALL GRID ARRAY

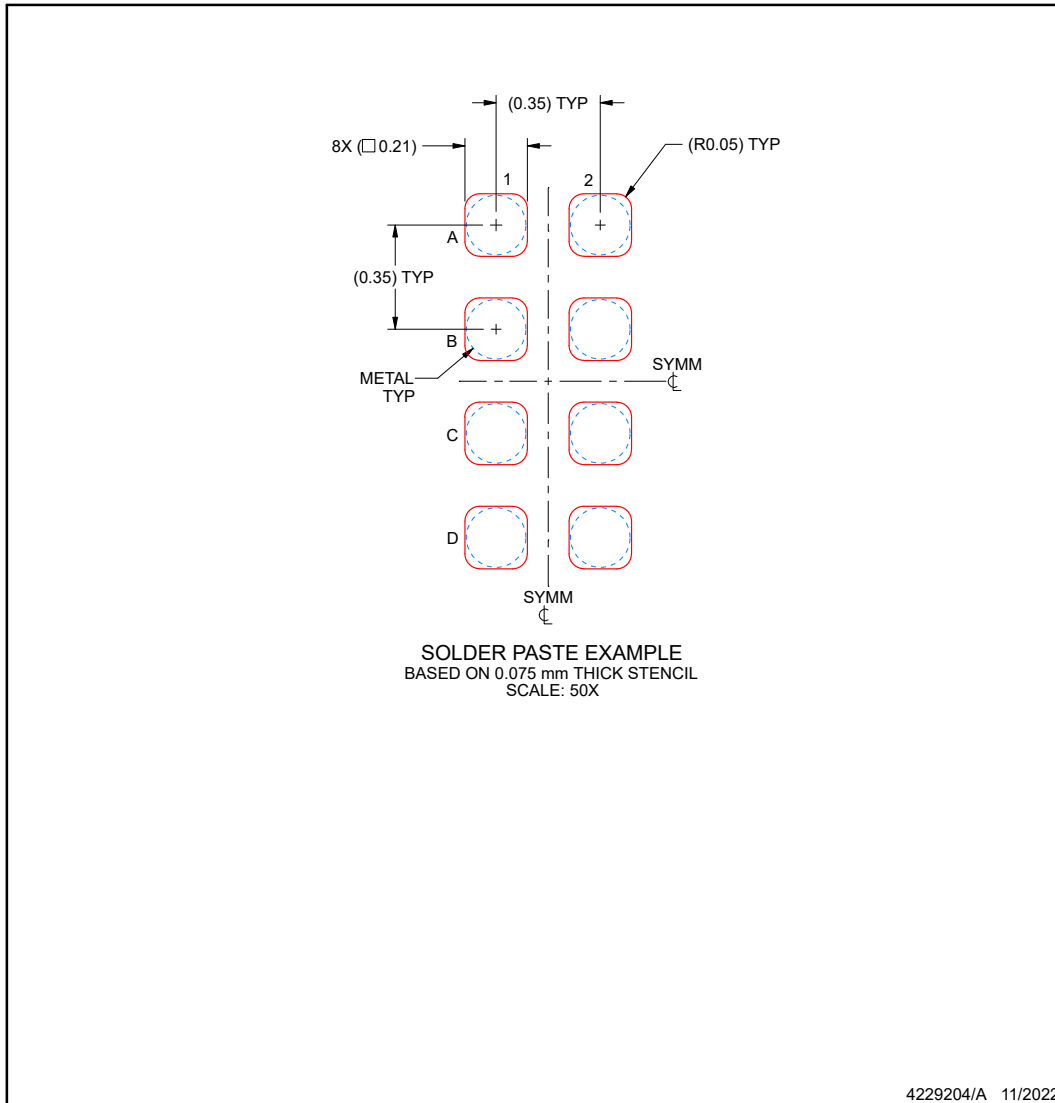

NOTES: (continued)

- 4. Laser cutting apertures with trapezoidal walls and rounded corners may offer better paste release.

PACKAGING INFORMATION

Orderable Device	Status (1)	Package Type	Package Drawing	Pins	Package Qty	Eco Plan (2)	Lead finish/ Ball material (6)	MSL Peak Temp (3)	Op Temp (°C)	Device Marking (4/5)	Samples
PTPS22999YCHR	ACTIVE	DSBGA	YCH	8	12000	TBD	Call TI	Call TI	-40 to 105		Samples
TPS22999YCHR	ACTIVE	DSBGA	YCH	8	12000	RoHS & Green	SNAGCU	Level-1-260C-UNLIM	-40 to 105	R	Samples

(1) The marketing status values are defined as follows:

ACTIVE: Product device recommended for new designs.

LIFEBUY: TI has announced that the device will be discontinued, and a lifetime-buy period is in effect.

NRND: Not recommended for new designs. Device is in production to support existing customers, but TI does not recommend using this part in a new design.

PREVIEW: Device has been announced but is not in production. Samples may or may not be available.

OBSOLETE: TI has discontinued the production of the device.

(2) **RoHS:** TI defines "RoHS" to mean semiconductor products that are compliant with the current EU RoHS requirements for all 10 RoHS substances, including the requirement that RoHS substance do not exceed 0.1% by weight in homogeneous materials. Where designed to be soldered at high temperatures, "RoHS" products are suitable for use in specified lead-free processes. TI may reference these types of products as "Pb-Free".

RoHS Exempt: TI defines "RoHS Exempt" to mean products that contain lead but are compliant with EU RoHS pursuant to a specific EU RoHS exemption.

Green: TI defines "Green" to mean the content of Chlorine (Cl) and Bromine (Br) based flame retardants meet JS709B low halogen requirements of <=1000ppm threshold. Antimony trioxide based flame retardants must also meet the <=1000ppm threshold requirement.

(3) MSL, Peak Temp. - The Moisture Sensitivity Level rating according to the JEDEC industry standard classifications, and peak solder temperature.

(4) There may be additional marking, which relates to the logo, the lot trace code information, or the environmental category on the device.

(5) Multiple Device Markings will be inside parentheses. Only one Device Marking contained in parentheses and separated by a "~" will appear on a device. If a line is indented then it is a continuation of the previous line and the two combined represent the entire Device Marking for that device.

(6) Lead finish/Ball material - Orderable Devices may have multiple material finish options. Finish options are separated by a vertical ruled line. Lead finish/Ball material values may wrap to two lines if the finish value exceeds the maximum column width.

Important Information and Disclaimer:The information provided on this page represents TI's knowledge and belief as of the date that it is provided. TI bases its knowledge and belief on information provided by third parties, and makes no representation or warranty as to the accuracy of such information. Efforts are underway to better integrate information from third parties. TI has taken and continues to take reasonable steps to provide representative and accurate information but may not have conducted destructive testing or chemical analysis on incoming materials and chemicals. TI and TI suppliers consider certain information to be proprietary, and thus CAS numbers and other limited information may not be available for release.

In no event shall TI's liability arising out of such information exceed the total purchase price of the TI part(s) at issue in this document sold by TI to Customer on an annual basis.

TAPE AND REEL INFORMATION

QUADRANT ASSIGNMENTS FOR PIN 1 ORIENTATION IN TAPE

*All dimensions are nominal

Device	Package Type	Package Drawing	Pins	SPQ	Reel Diameter (mm)	Reel Width W1 (mm)	A0 (mm)	B0 (mm)	K0 (mm)	P1 (mm)	W (mm)	Pin1 Quadrant
TPS22999YCHR	DSBGA	YCH	8	12000	180.0	8.4	0.84	1.62	0.43	2.0	8.0	Q1
TPS22999YCHR	DSBGA	YCH	8	12000	180.0	8.4	0.81	1.53	0.43	2.0	8.0	Q1

TAPE AND REEL BOX DIMENSIONS

*All dimensions are nominal

Device	Package Type	Package Drawing	Pins	SPQ	Length (mm)	Width (mm)	Height (mm)
TPS22999YCHR	DSBGA	YCH	8	12000	182.0	182.0	20.0
TPS22999YCHR	DSBGA	YCH	8	12000	182.0	182.0	20.0

IMPORTANT NOTICE AND DISCLAIMER

TI PROVIDES TECHNICAL AND RELIABILITY DATA (INCLUDING DATA SHEETS), DESIGN RESOURCES (INCLUDING REFERENCE DESIGNS), APPLICATION OR OTHER DESIGN ADVICE, WEB TOOLS, SAFETY INFORMATION, AND OTHER RESOURCES "AS IS" AND WITH ALL FAULTS, AND DISCLAIMS ALL WARRANTIES, EXPRESS AND IMPLIED, INCLUDING WITHOUT LIMITATION ANY IMPLIED WARRANTIES OF MERCHANTABILITY, FITNESS FOR A PARTICULAR PURPOSE OR NON-INFRINGEMENT OF THIRD PARTY INTELLECTUAL PROPERTY RIGHTS.

These resources are intended for skilled developers designing with TI products. You are solely responsible for (1) selecting the appropriate TI products for your application, (2) designing, validating and testing your application, and (3) ensuring your application meets applicable standards, and any other safety, security, regulatory or other requirements.

These resources are subject to change without notice. TI grants you permission to use these resources only for development of an application that uses the TI products described in the resource. Other reproduction and display of these resources is prohibited. No license is granted to any other TI intellectual property right or to any third party intellectual property right. TI disclaims responsibility for, and you will fully indemnify TI and its representatives against, any claims, damages, costs, losses, and liabilities arising out of your use of these resources.

TI's products are provided subject to [TI's Terms of Sale](#) or other applicable terms available either on [ti.com](https://www.ti.com) or provided in conjunction with such TI products. TI's provision of these resources does not expand or otherwise alter TI's applicable warranties or warranty disclaimers for TI products.

TI objects to and rejects any additional or different terms you may have proposed.

Mailing Address: Texas Instruments, Post Office Box 655303, Dallas, Texas 75265
Copyright © 2024, Texas Instruments Incorporated