

# bq78z100 Impedance Track™ Gas Gauge for 1-Series to 2-Series Li-Ion/Li-Polymer Battery Packs

Check for Samples: [bq78z100](#)

## 1 Features

- High-Accuracy Coulomb Counter with Input Offset Error < 1  $\mu$ V (Typical)
- High-Side FET Drive Allows Serial Bus Communication During Fault Conditions
- Analog Front End with Two Independent ADCs
  - Support for Simultaneous Current and Voltage Sampling
- Bus Communications Interface Options
  - I<sup>2</sup>C
  - HDQ
- SHA-1 Hash Message Authentication Code (HMAC) Responder for Increased Battery Pack Security
  - Split Key (2  $\times$  64) Stored in Secure Memory
- Programmable Protection Levels for:
  - Overcurrent in Discharge
  - Short-Circuit Current in Charge
  - Short-Circuit Current in Discharge
  - Overvoltage
  - Undervoltage
  - Overtemperature
- Supports a 1-m $\Omega$  to 3-m $\Omega$  Current Sense Resistor
- Compact 12-Terminal SON Package (DRZ)

## 2 Applications

- Portable and Wearable Health Devices
- Portable Radios
- Industrial Data Collection

## 3 Description

The bq78z100 device provides a fully integrated pack-based solution with a flash programmable custom reduced instruction-set CPU (RISC), safety protection, and authentication for 1-series to 2-series cell Li-Ion and Li-Polymer battery packs.

The bq78z100 gas gauge communicates via an I<sup>2</sup>C-compatible interface or single-wire HDQ interface and combines an ultra-low-power, high-speed TI bqBMP processor, high-accuracy analog measurement capabilities, integrated flash memory, an array of peripheral and communication ports, an N-channel FET drive, and a SHA-1 Authentication transform responder into a complete, high-performance battery management solution.

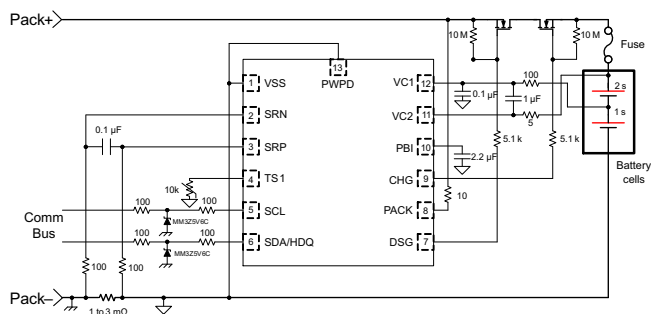
The bq78z100 device provides an array of battery and system safety functions, including overcurrent in discharge, short circuit in charge, and short circuit in discharge protection for the battery, as well as FET protection for the N-channel FETs, internal AFE watchdog, and cell balancing. Through firmware, the devices can provide a larger array of features including protection against overvoltage, undervoltage, overtemperature, and more.

### Device Information<sup>(1)</sup>

PART NUMBER	PACKAGE	BODY SIZE (NOM)
bq78z100	VSON (12)	4.00 mm $\times$ 2.50 mm

(1) For all available packages, see the orderable addendum at the end of the data sheet.

## 4 Simplified Schematic



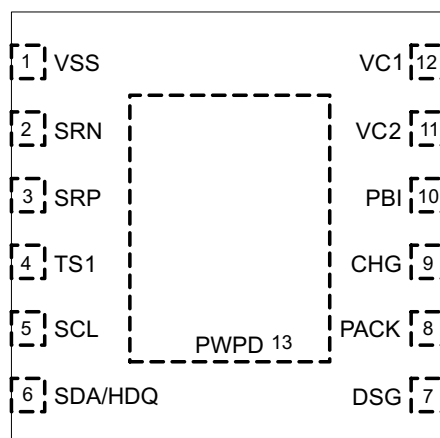
## Table of Contents

<b>1</b>	<b>Features</b> .....	<b>1</b>	7.22	Data Flash.....	<b>9</b>
<b>2</b>	<b>Applications</b> .....	<b>1</b>	7.23	Current Protection Thresholds .....	<b>10</b>
<b>3</b>	<b>Description</b> .....	<b>1</b>	7.24	Current Protection Timing .....	<b>10</b>
<b>4</b>	<b>Simplified Schematic</b> .....	<b>1</b>	7.25	N-CH FET Drive (CHG, DSG).....	<b>11</b>
<b>5</b>	<b>Revision History</b> .....	<b>2</b>	7.26	I <sup>2</sup> C and HDQ Interface I/O .....	<b>11</b>
<b>6</b>	<b>Pin Configuration and Functions</b> .....	<b>3</b>	7.27	I <sup>2</sup> C Interface Timing .....	<b>12</b>
<b>7</b>	<b>Specifications</b> .....	<b>4</b>	7.28	HDQ Interface Timing .....	<b>12</b>
7.1	Absolute Maximum Ratings .....	<b>4</b>	7.29	Typical Characteristics .....	<b>14</b>
7.2	ESD Ratings .....	<b>4</b>	<b>8</b>	<b>Detailed Description</b> .....	<b>17</b>
7.3	Recommended Operating Conditions.....	<b>4</b>	8.1	Overview .....	<b>17</b>
7.4	Thermal Information .....	<b>5</b>	8.2	Functional Block Diagram .....	<b>17</b>
7.5	Supply Current .....	<b>5</b>	8.3	Feature Description .....	<b>18</b>
7.6	Power Supply Control .....	<b>5</b>	8.4	Device Functional Modes.....	<b>22</b>
7.7	Low-Voltage General Purpose I/O, TS1 .....	<b>6</b>	<b>9</b>	<b>Applications and Implementation</b> .....	<b>24</b>
7.8	Power-On Reset (POR) .....	<b>6</b>	9.1	Application Information.....	<b>24</b>
7.9	Internal 1.8-V LDO .....	<b>6</b>	9.2	Typical Applications .....	<b>24</b>
7.10	Current Wake Comparator.....	<b>6</b>	<b>10</b>	<b>Power Supply Requirements</b> .....	<b>27</b>
7.11	Coulomb Counter.....	<b>7</b>	<b>11</b>	<b>Layout</b> .....	<b>28</b>
7.12	ADC Digital Filter .....	<b>7</b>	11.1	Layout Guidelines .....	<b>28</b>
7.13	ADC Multiplexer .....	<b>7</b>	11.2	Layout Example .....	<b>29</b>
7.14	Cell Balancing Support .....	<b>8</b>	<b>12</b>	<b>Device and Documentation Support</b> .....	<b>30</b>
7.15	Internal Temperature Sensor .....	<b>8</b>	12.1	Documentation Support .....	<b>30</b>
7.16	NTC Thermistor Measurement Support.....	<b>8</b>	12.2	Community Resources.....	<b>30</b>
7.17	High-Frequency Oscillator.....	<b>8</b>	12.3	Trademarks .....	<b>30</b>
7.18	Low-Frequency Oscillator .....	<b>8</b>	12.4	Electrostatic Discharge Caution.....	<b>30</b>
7.19	Voltage Reference 1 .....	<b>9</b>	12.5	Glossary .....	<b>30</b>
7.20	Voltage Reference 2 .....	<b>9</b>	<b>13</b>	<b>Mechanical, Packaging, and Orderable Information</b> .....	<b>31</b>
7.21	Instruction Flash.....	<b>9</b>			

## 5 Revision History

DATE	REVISION	NOTES
September 2015	*	Initial Release

## 6 Pin Configuration and Functions



**Pin Functions**

PIN		I/O	DESCRIPTION
NAME	DRZ		
VSS	1	P	Device ground
SRN	2	IA	Analog input pin connected to the internal coulomb counter peripheral for integrating a small voltage between SRP and SRN where SRP is the top of the sense resistor.
SRP	3	IA	Analog input pin connected to the internal coulomb counter peripheral for integrating a small voltage between SRP and SRN where SRP is the top of the sense resistor.
TS1	4	IA	Input for ADC to the oversampled ADC channel
SCL	5	I/O	Serial Clock for the I <sup>2</sup> C interface; requires an external pullup when used
SDA/HDQ	6	I/O	Serial Data for the I <sup>2</sup> C and HDQ interfaces; requires an external pullup
DSG	7	O	N-Channel FET drive output pin
PACK	8	IA, P	Pack sense input pin
CHG	9	O	N-Channel FET drive output pin
PBI	10	P	Power supply backup input pin
VC2	11	IA, P	Sense voltage input pin for most positive cell, balance current input for most positive cell. Primary power supply input and battery stack measurement input (BAT)
VC1	12	IA	Sense voltage input pin for least positive cell, balance current input for least positive cell
PWPD		—	Exposed Pad, electrically connected to VSS (external trace)

## 7 Specifications

### 7.1 Absolute Maximum Ratings

Over operating free-air temperature range (unless otherwise noted)<sup>(1)</sup>

		MIN	MAX	UNIT
Supply voltage range, $V_{CC}$	VC2, PBI	-0.3	30	V
Input voltage range, $V_{IN}$	PACK	-0.3	30	V
	TS1	-0.3	$V_{REG} + 0.3$	V
	SRP, SRN	-0.3	0.3	V
	VC2	$VC1 - 0.3$	$VC1 + 8.5$ or $VSS + 30$	V
	VC1	$VSS - 0.3$	$VSS + 8.5$ or $VSS + 30$	V
Output voltage range, $V_O$	CHG, DSG	-0.3	32	V
Maximum VSS current, $I_{SS}$			±50	mA
Functional Temperature, $T_{FUNC}$		-40	110	°C
Lead temperature (soldering, 10 s), $T_{SOLDER}$			±300	
Storage temperature range, $T_{STG}$		-65	150	°C

(1) Stresses beyond those listed under *absolute maximum ratings* may cause permanent damage to the device. These are stress ratings only, and functional operation of the device at these or any other conditions beyond those indicated under *recommended operating conditions* is not implied. Exposure to absolute-maximum-rated conditions for extended periods may affect device reliability.

### 7.2 ESD Ratings

		VALUE	UNIT
$V_{(ESD)}$ Electrostatic discharge	Human body model (HBM), per ANSI/ESDA/JEDEC JS-001, all pins <sup>(1)</sup>	±2000	V
	Charged device model (CDM), per JEDEC specification JESD22-C101, all pins <sup>(2)</sup>	±500	

(1) JEDEC document JEP155 states that 500-V HBM allows safe manufacturing with a standard ESD control process.

(2) JEDEC document JEP157 states that 250-V CDM allows safe manufacturing with a standard ESD control process.

### 7.3 Recommended Operating Conditions

Typical values stated where  $T_A = 25^\circ\text{C}$  and  $V_{CC} = 7.2\text{ V}$ , Min/Max values stated where  $T_A = -40^\circ\text{C}$  to  $85^\circ\text{C}$  and  $V_{CC} = 2.2\text{ V}$  to  $26\text{ V}$  (unless otherwise noted)

			MIN	NOM	MAX	UNIT
$V_{CC}$	Supply voltage	VC2, PBI	2.2		26	V
$V_{SHUTDOWN-}$	Shutdown voltage	$V_{PACK} < V_{SHUTDOWN-}$	1.8	2.0	2.2	V
$V_{SHUTDOWN+}$	Start-up voltage	$V_{PACK} > V_{SHUTDOWN-} + V_{HYS}$	2.05	2.25	2.45	V
$V_{HYS}$	Shutdown voltage hysteresis	$V_{SHUTDOWN+} - V_{SHUTDOWN-}$		250		mV
$V_{IN}$	Input voltage range	SDA/HDQ, SCL			5.5	V
		TS1			$V_{REG}$	
		SRP, SRN	-0.2		0.2	
		VC2	$V_{VC1}$		$V_{VC1} + 5$	
		VC1	$V_{VSS}$		$V_{VSS} + 5$	
		PACK			26	
$V_O$	Output voltage range	CHG, DSG			26	V
$C_{PBI}$	External PBI capacitor		2.2			µF
$T_{OPR}$	Operating temperature		-40		85	°C

## 7.4 Thermal Information

over operating free-air temperature range (unless otherwise noted)

THERMAL METRIC <sup>(1)</sup>		bq78z100		UNIT
		DRZ		
		12 PINS		
R <sub>θJA, High K</sub>	Junction-to-ambient thermal resistance	186.4		°C/W
R <sub>θJC(top)</sub>	Junction-to-case(top) thermal resistance	90.4		
R <sub>θJB</sub>	Junction-to-board thermal resistance	110.7		
Ψ <sub>JT</sub>	Junction-to-top characterization parameter	96.7		
Ψ <sub>JB</sub>	Junction-to-board characterization parameter	90		
R <sub>θJC(bottom)</sub>	Junction-to-case(bottom) thermal resistance	n/a		

(1) For more information about traditional and new thermal metrics, see the Semiconductor and IC Package Thermal Metrics application report, [SPRA953](#).

## 7.5 Supply Current

Typical values stated where T<sub>A</sub> = 25°C and VCC = 7.2 V, Min/Max values stated where T<sub>A</sub> = –40°C to 85°C and VCC = 2.2 V to 7.6 V (unless otherwise noted)

PARAMETER		TEST CONDITION	MIN	TYP	MAX	UNIT
I <sub>NORMAL</sub>	NORMAL mode	CHG = ON, DSG = ON, No Flash Write and CPU = ON		400	500	μA
		CHG = ON, DSG = ON, No Flash Write and CPU = Halted		250	300	
I <sub>SLEEP</sub>	SLEEP mode	CHG = OFF, DSG = ON, No Communication on Bus		90	160	μA
		CHG = OFF, DSG = OFF, No Communication on Bus		38	120	
I <sub>SHUTDOWN</sub>	SHUTDOWN mode			0.5	2	μA

## 7.6 Power Supply Control

Typical values stated where T<sub>A</sub> = 25°C and VCC = 7.2 V, Min/Max values stated where T<sub>A</sub> = –40°C to 85°C and VCC = 2.2 V to 7.6 V (unless otherwise noted)

PARAMETER		TEST CONDITION	MIN	TYP	MAX	UNIT
V <sub>SWITCHOVER-</sub>	VC2 to PACK switchover voltage	V <sub>VC2</sub> < V <sub>SWITCHOVER-</sub>	2.0	2.1	2.2	V
V <sub>SWITCHOVER+</sub>	PACK to VC2 switchover voltage	V <sub>VC2</sub> > V <sub>SWITCHOVER-</sub> + V <sub>HYS</sub>	3.0	3.1	3.2	V
V <sub>HYS</sub>	Switchover voltage hysteresis	V <sub>SWITCHOVER+</sub> – V <sub>SWITCHOVER-</sub>		1000		mV
I <sub>LKG</sub>	Input Leakage current	VC2 pin, VC2 = 0 V, PACK = 25 V			1	μA
		PACK pin, VC2 = 25 V, PACK = 0 V			1	
		VC2 and PACK pins, VC2 = 0 V, PACK = 0 V, PBI = 25 V			1	
R <sub>PACK(PD)</sub>	Internal pulldown resistance	PACK	30	40	50	kΩ

## 7.7 Low-Voltage General Purpose I/O, TS1

Typical values stated where  $T_A = 25^\circ\text{C}$  and  $V_{CC} = 7.2\text{ V}$ , Min/Max values stated where  $T_A = -40^\circ\text{C}$  to  $85^\circ\text{C}$  and  $V_{CC} = 2.2\text{ V}$  to  $7.6\text{ V}$  (unless otherwise noted)

PARAMETER	TEST CONDITION	MIN	TYP	MAX	UNIT
$V_{IH}$	High-level input	$0.65 \times V_{REG}$			V
$V_{IL}$	Low-level input	$0.35 \times V_{REG}$			V
$V_{OH}$	Output voltage high	$I_{OH} = -1.0\text{ mA}$	$0.75 \times V_{REG}$		V
$V_{OL}$	Output voltage low	$I_{OL} = 1.0\text{ mA}$	$0.2 \times V_{REG}$		V
$C_{IN}$	Input capacitance	5			pF
$I_{LKG}$	Input leakage current	1			$\mu\text{A}$

## 7.8 Power-On Reset (POR)

Typical values stated where  $T_A = 25^\circ\text{C}$  and  $V_{CC} = 7.2\text{ V}$ , Min/Max values stated where  $T_A = -40^\circ\text{C}$  to  $85^\circ\text{C}$  and  $V_{CC} = 2.2\text{ V}$  to  $7.6\text{ V}$  (unless otherwise noted)

PARAMETER	TEST CONDITION	MIN	TYP	MAX	UNIT		
$V_{REGIT-}$	Negative-going voltage input	$V_{REG}$	1.51	1.55	1.59	V	
$V_{HYS}$	Power-on reset hysteresis	$V_{REGIT+} - V_{REGIT-}$		70	100	130	mV
$t_{RST}$	Power-on reset time	200	300	400	$\mu\text{s}$		

## 7.9 Internal 1.8-V LDO

Typical values stated where  $T_A = 25^\circ\text{C}$  and  $V_{CC} = 7.2\text{ V}$ , Min/Max values stated where  $T_A = -40^\circ\text{C}$  to  $85^\circ\text{C}$  and  $V_{CC} = 2.2\text{ V}$  to  $7.6\text{ V}$  (unless otherwise noted)

PARAMETER	TEST CONDITION	MIN	TYP	MAX	UNIT			
$V_{REG}$	Regulator voltage	1.6	1.8	2.0	V			
$\Delta V_{O(TEMP)}$	Regulator output over temperature	$\Delta V_{REG}/\Delta T_A, I_{REG} = 10\text{ mA}$			$\pm 0.25\%$			
$\Delta V_{O(LINE)}$	Line regulation	$\Delta V_{REG}/\Delta V_{BAT}, V_{BAT} = 10\text{ mA}$			-0.6% 0.5%			
$\Delta V_{O(LOAD)}$	Load regulation	$\Delta V_{REG}/\Delta I_{REG}, I_{REG} = 0\text{ mA}$ to $10\text{ mA}$			-1.5% 1.5%			
$I_{REG}$	Regulator output current limit	$V_{REG} = 0.9 \times V_{REG(NOM)}, V_{IN} > 2.2\text{ V}$			20	mA		
$I_{SC}$	Regulator short-circuit current limit	$V_{REG} = 0 \times V_{REG(NOM)}$			25	40	50	mA
$PSRR_{REG}$	Power supply rejection ratio	$\Delta V_{BAT}/\Delta V_{REG}, I_{REG} = 10\text{ mA}, V_{IN} > 2.5\text{ V}, f = 10\text{ Hz}$			40	dB		
$V_{SLEW}$	Slew rate enhancement voltage threshold	$V_{REG}$			1.58	1.65	V	

## 7.10 Current Wake Comparator

Typical values stated where  $T_A = 25^\circ\text{C}$  and  $V_{CC} = 7.2\text{ V}$ , Min/Max values stated where  $T_A = -40^\circ\text{C}$  to  $85^\circ\text{C}$  and  $V_{CC} = 2.2\text{ V}$  to  $7.6\text{ V}$  (unless otherwise noted)

PARAMETER	TEST CONDITION	MIN	TYP	MAX	UNIT			
$V_{WAKE}$	Wake voltage threshold	$V_{WAKE} = V_{SRP} - V_{SRN}$ WAKE_CONTROL[WK1, WK0] = 0,0			$\pm 0.3$	$\pm 0.625$	$\pm 0.9$	mV
		$V_{WAKE} = V_{SRP} - V_{SRN}$ WAKE_CONTROL[WK1, WK0] = 0,1			$\pm 0.6$	$\pm 1.25$	$\pm 1.8$	mV
		$V_{WAKE} = V_{SRP} - V_{SRN}$ WAKE_CONTROL[WK1, WK0] = 1,0			$\pm 1.2$	$\pm 2.5$	$\pm 3.6$	mV
		$V_{WAKE} = V_{SRP} - V_{SRN}$ WAKE_CONTROL[WK1, WK0] = 1,1			$\pm 2.4$	$\pm 5.0$	$\pm 7.2$	mV

## Current Wake Comparator (continued)

Typical values stated where  $T_A = 25^\circ\text{C}$  and  $V_{CC} = 7.2\text{ V}$ , Min/Max values stated where  $T_A = -40^\circ\text{C}$  to  $85^\circ\text{C}$  and  $V_{CC} = 2.2\text{ V}$  to  $7.6\text{ V}$  (unless otherwise noted)

PARAMETER	TEST CONDITION	MIN	TYP	MAX	UNIT
$V_{\text{WAKE(DRIFT)}}$ Temperature drift of $V_{\text{WAKE}}$ accuracy			0.5%		$^\circ\text{C}$
$t_{\text{WAKE}}$ Time from application of current to wake			0.25	0.5	ms
$t_{\text{WAKE(SU)}}$ Wake up comparator startup time	[WKCHGEN] = 0 and [WKDSGEN] = 0 to [WKCHGEN] = 1 and [WKDSGEN] = 1		250	640	$\mu\text{s}$

## 7.11 Coulomb Counter

Typical values stated where  $T_A = 25^\circ\text{C}$  and  $V_{CC} = 7.2\text{ V}$ , Min/Max values stated where  $T_A = -40^\circ\text{C}$  to  $85^\circ\text{C}$  and  $V_{CC} = 2.2\text{ V}$  to  $7.6\text{ V}$  (unless otherwise noted)

PARAMETER	TEST CONDITION	MIN	TYP	MAX	UNIT
Input voltage range		-100		100	mV
Full scale range		$-V_{\text{REF1}}/10$		$+V_{\text{REF1}}/10$	mV
Differential nonlinearity	16-bit, No missing codes			$\pm 1$	LSB
Integral nonlinearity	16-bit, Best fit over input voltage range		$\pm 5.2$	$\pm 22.3$	LSB
Offset error	16-bit, Post-calibration		$\pm 1.3$	$\pm 2.6$	LSB
Offset error drift	15-bit + sign, Post-calibration		0.04	0.07	LSB/ $^\circ\text{C}$
Gain error	15-bit + sign, Over input voltage range		$\pm 131$	$\pm 492$	LSB
Gain error drift	15-bit + sign, Over input voltage range		4.3	9.8	LSB/ $^\circ\text{C}$
Effective input resistance		2.5			M $\Omega$

## 7.12 ADC Digital Filter

Typical values stated where  $T_A = 25^\circ\text{C}$  and  $V_{CC} = 7.2\text{ V}$ , Min/Max values stated where  $T_A = -40^\circ\text{C}$  to  $85^\circ\text{C}$  and  $V_{CC} = 2.2\text{ V}$  to  $7.6\text{ V}$  (unless otherwise noted)

PARAMETER	TEST CONDITION	MIN	TYP	MAX	UNIT
$t_{\text{CONV}}$	ADCTL[SPEED1, SPEED0] = 0, 0		31.25		ms
	ADCTL[SPEED1, SPEED0] = 0, 1		15.63		
	ADCTL[SPEED1, SPEED0] = 1, 0		7.81		
	ADCTL[SPEED1, SPEED0] = 1, 1		1.95		
Resolution	No missing codes, ADCTL[SPEED1, SPEED0] = 0, 0		16		Bits
Effective resolution	With sign, ADCTL[SPEED1, SPEED0] = 0, 0	14	15		Bits
	With sign, ADCTL[SPEED1, SPEED0] = 0, 1	13	14		
	With sign, ADCTL[SPEED1, SPEED0] = 1, 0	11	12		
	With sign, ADCTL[SPEED1, SPEED0] = 1, 1	9	10		

## 7.13 ADC Multiplexer

Typical values stated where  $T_A = 25^\circ\text{C}$  and  $V_{CC} = 7.2\text{ V}$ , Min/Max values stated where  $T_A = -40^\circ\text{C}$  to  $85^\circ\text{C}$  and  $V_{CC} = 2.2\text{ V}$  to  $7.6\text{ V}$  (unless otherwise noted)

PARAMETER	TEST CONDITION	MIN	TYP	MAX	UNIT
K Scaling factor	VC1-VSS, VC2-VC1	0.1980	0.2000	0.2020	—
	VC2-VSS, PACK-VSS	0.0485	0.050	0.051	
	$V_{\text{REF1}}/2$	0.490	0.500	0.510	
$V_{\text{IN}}$ Input voltage range	VC2-VSS, PACK-VSS	-0.2		20	V
	TS1	-0.2		$0.8 \times V_{\text{REF1}}$	
	TS1	-0.2		$0.8 \times V_{\text{REG}}$	
$I_{\text{LKG}}$ Input leakage current	VC1, VC2 cell balancing off, cell detach detection off, ADC multiplexer off			1	$\mu\text{A}$

## 7.14 Cell Balancing Support

Typical values stated where  $T_A = 25^\circ\text{C}$  and  $V_{CC} = 7.2\text{ V}$ , Min/Max values stated where  $T_A = -40^\circ\text{C}$  to  $85^\circ\text{C}$  and  $V_{CC} = 2.2\text{ V}$  to  $7.6\text{ V}$  (unless otherwise noted)

PARAMETER		TEST CONDITION	MIN	TYP	MAX	UNIT
$R_{CB}$	Internal cell balance resistance	$R_{DS(ON)}$ for internal FET switch at $2\text{ V} < V_{DS} < 4\text{ V}$			200	$\Omega$

## 7.15 Internal Temperature Sensor

Typical values stated where  $T_A = 25^\circ\text{C}$  and  $V_{CC} = 7.2\text{ V}$ , Min/Max values stated where  $T_A = -40^\circ\text{C}$  to  $85^\circ\text{C}$  and  $V_{CC} = 2.2\text{ V}$  to  $7.6\text{ V}$  (unless otherwise noted)

PARAMETER		TEST CONDITION	MIN	TYP	MAX	UNIT
$V_{TEMP}$	Internal temperature sensor voltage drift	$V_{TEMP}$	-1.9	-2.0	-2.1	mV/ $^\circ\text{C}$
		$V_{TEMP} - V_{TEMPN}^{(1)}$	0.177	0.178	0.179	

(1) Assured by design

## 7.16 NTC Thermistor Measurement Support

Typical values stated where  $T_A = 25^\circ\text{C}$  and  $V_{CC} = 7.2\text{ V}$ , Min/Max values stated where  $T_A = -40^\circ\text{C}$  to  $85^\circ\text{C}$  and  $V_{CC} = 2.2\text{ V}$  to  $7.6\text{ V}$  (unless otherwise noted)

PARAMETER		TEST CONDITION	MIN	TYP	MAX	UNIT
$R_{NTC(PU)}$	Internal pull-up resistance	TS1	14.4	18	21.6	k $\Omega$
$R_{NTC(DRIFT)}$	Resistance drift over temperature	TS1	-360	-280	-200	PPM/ $^\circ\text{C}$

## 7.17 High-Frequency Oscillator

Typical values stated where  $T_A = 25^\circ\text{C}$  and  $V_{CC} = 7.2\text{ V}$ , Min/Max values stated where  $T_A = -40^\circ\text{C}$  to  $85^\circ\text{C}$  and  $V_{CC} = 2.2\text{ V}$  to  $7.6\text{ V}$  (unless otherwise noted)

PARAMETER		TEST CONDITION	MIN	TYP	MAX	UNIT
$f_{HFO}$	Operating frequency			16.78		MHz
$f_{HFO(ERR)}$	Frequency error	$T_A = -20^\circ\text{C}$ to $70^\circ\text{C}$ , includes frequency drift	-2.5%	$\pm 0.25\%$	2.5%	
		$T_A = -40^\circ\text{C}$ to $85^\circ\text{C}$ , includes frequency drift	-3.5%	$\pm 0.25\%$	3.5%	
$t_{HFO(SU)}$	Start-up time	$T_A = -20^\circ\text{C}$ to $85^\circ\text{C}$ , Oscillator frequency within $\pm 3\%$ of nominal, CLKCTL[HFRAMP] = 1			4	ms
		Oscillator frequency within $\pm 3\%$ of nominal, CLKCTL[HFRAMP] = 0			100	$\mu\text{s}$

## 7.18 Low-Frequency Oscillator

Typical values stated where  $T_A = 25^\circ\text{C}$  and  $V_{CC} = 7.2\text{ V}$ , Min/Max values stated where  $T_A = -40^\circ\text{C}$  to  $85^\circ\text{C}$  and  $V_{CC} = 2.2\text{ V}$  to  $7.6\text{ V}$  (unless otherwise noted)

PARAMETER		TEST CONDITION	MIN	TYP	MAX	UNIT
$f_{LFO}$	Operating frequency			262.144		kHz
$f_{LFO(LP)}$	Operating frequency in low power mode			247		kHz
$f_{LFO(ERR)}$	Frequency error	$T_A = -20^\circ\text{C}$ to $70^\circ\text{C}$ , includes frequency drift	-1.5%	$\pm 0.25\%$	1.5%	
		$T_A = -40^\circ\text{C}$ to $85^\circ\text{C}$ , includes frequency drift	-2.5%	$\pm 0.25\%$	2.5%	
$f_{LFO(LPERR)}$	Frequency error in low power mode			-5%	5%	
$f_{LFO(FAIL)}$	Failure detection frequency		30	80	100	kHz



## 7.19 Voltage Reference 1

Typical values stated where  $T_A = 25^\circ\text{C}$  and  $V_{CC} = 7.2\text{ V}$ , Min/Max values stated where  $T_A = -40^\circ\text{C}$  to  $85^\circ\text{C}$  and  $V_{CC} = 2.2\text{ V}$  to  $7.6\text{ V}$  (unless otherwise noted)

PARAMETER		TEST CONDITION	MIN	TYP	MAX	UNIT
$V_{REF1}$	Internal reference voltage	$T_A = 25^\circ\text{C}$ , after trim	1.215	1.220	1.225	V
$V_{REF1(DRIFT)}$	Internal reference voltage drift	$T_A = 0^\circ\text{C}$ to $60^\circ\text{C}$ , after trim		$\pm 50$		PPM/ $^\circ\text{C}$
		$T_A = -40^\circ\text{C}$ to $85^\circ\text{C}$ , after trim		$\pm 80$		

## 7.20 Voltage Reference 2

Typical values stated where  $T_A = 25^\circ\text{C}$  and  $V_{CC} = 7.2\text{ V}$ , Min/Max values stated where  $T_A = -40^\circ\text{C}$  to  $85^\circ\text{C}$  and  $V_{CC} = 2.2\text{ V}$  to  $7.6\text{ V}$  (unless otherwise noted)

PARAMETER		TEST CONDITION	MIN	TYP	MAX	UNIT
$V_{REF2}$	Internal reference voltage	$T_A = 25^\circ\text{C}$ , after trim	1.215	1.220	1.225	V
$V_{REF2(DRIFT)}$	Internal reference voltage drift	$T_A = 0^\circ\text{C}$ to $60^\circ\text{C}$ , after trim		$\pm 50$		PPM/ $^\circ\text{C}$
		$T_A = -40^\circ\text{C}$ to $85^\circ\text{C}$ , after trim		$\pm 80$		

## 7.21 Instruction Flash

Typical values stated where  $T_A = 25^\circ\text{C}$  and  $V_{CC} = 7.2\text{ V}$ , Min/Max values stated where  $T_A = -40^\circ\text{C}$  to  $85^\circ\text{C}$  and  $V_{CC} = 2.2\text{ V}$  to  $7.6\text{ V}$  (unless otherwise noted)

PARAMETER		TEST CONDITION	MIN	TYP	MAX	UNIT
Data retention			10			Years
Flash programming write cycles			1000			Cycles
$t_{PROGWORD}$	Word programming time	$T_A = -40^\circ\text{C}$ to $85^\circ\text{C}$			40	$\mu\text{s}$
$t_{MASSERASE}$	Mass-erase time	$T_A = -40^\circ\text{C}$ to $85^\circ\text{C}$			40	ms
$t_{PAGEERASE}$	Page-erase time	$T_A = -40^\circ\text{C}$ to $85^\circ\text{C}$			40	ms
$I_{FLASHREAD}$	Flash-read current	$T_A = -40^\circ\text{C}$ to $85^\circ\text{C}$			2	mA
$I_{FLASHWRITE}$	Flash-write current	$T_A = -40^\circ\text{C}$ to $85^\circ\text{C}$			5	mA
$I_{FLASHERASE}$	Flash-erase current	$T_A = -40^\circ\text{C}$ to $85^\circ\text{C}$			15	mA

## 7.22 Data Flash

Typical values stated where  $T_A = 25^\circ\text{C}$  and  $V_{CC} = 7.2\text{ V}$ , Min/Max values stated where  $T_A = -40^\circ\text{C}$  to  $85^\circ\text{C}$  and  $V_{CC} = 2.2\text{ V}$  to  $7.6\text{ V}$  (unless otherwise noted)

PARAMETER		TEST CONDITION	MIN	TYP	MAX	UNIT
Data retention			10			Years
Flash programming write cycles			20000			Cycles
$t_{PROGWORD}$	Word programming time	$T_A = -40^\circ\text{C}$ to $85^\circ\text{C}$			40	$\mu\text{s}$
$t_{MASSERASE}$	Mass-erase time	$T_A = -40^\circ\text{C}$ to $85^\circ\text{C}$			40	ms
$t_{PAGEERASE}$	Page-erase time	$T_A = -40^\circ\text{C}$ to $85^\circ\text{C}$			40	ms
$I_{FLASHREAD}$	Flash-read current	$T_A = -40^\circ\text{C}$ to $85^\circ\text{C}$			1	mA
$I_{FLASHWRITE}$	Flash-write current	$T_A = -40^\circ\text{C}$ to $85^\circ\text{C}$			5	mA
$I_{FLASHERASE}$	Flash-erase current	$T_A = -40^\circ\text{C}$ to $85^\circ\text{C}$			15	mA

## 7.23 Current Protection Thresholds

Typical values stated where  $T_A = 25^\circ\text{C}$  and  $V_{CC} = 7.2\text{ V}$ , Min/Max values stated where  $T_A = -40^\circ\text{C}$  to  $85^\circ\text{C}$  and  $V_{CC} = 2.2\text{ V}$  to  $7.6\text{ V}$  (unless otherwise noted)

PARAMETER		TEST CONDITION	MIN	TYP	MAX	UNIT
$V_{\text{OCD}}$	OCD detection threshold voltage range	$V_{\text{OCD}} = V_{\text{SRP}} - V_{\text{SRN}}$ , PROTECTION_CONTROL[RSNS] = 1	-16.6		-100	mV
		$V_{\text{OCD}} = V_{\text{SRP}} - V_{\text{SRN}}$ , PROTECTION_CONTROL[RSNS] = 0	-8.3		-50	
$\Delta V_{\text{OCD}}$	OCD detection threshold voltage program step	$V_{\text{OCD}} = V_{\text{SRP}} - V_{\text{SRN}}$ , PROTECTION_CONTROL[RSNS] = 1		-5.56		mV
		$V_{\text{OCD}} = V_{\text{SRP}} - V_{\text{SRN}}$ , PROTECTION_CONTROL[RSNS] = 0		-2.78		
$\Delta V_{\text{SCC}}$	SCC detection threshold voltage range	$V_{\text{SCC}} = V_{\text{SRP}} - V_{\text{SRN}}$ , PROTECTION_CONTROL[RSNS] = 1	44.4		200	mV
		$V_{\text{SCC}} = V_{\text{SRP}} - V_{\text{SRN}}$ , PROTECTION_CONTROL[RSNS] = 0	22.2		100	
$\Delta V_{\text{SCC}}$	SCC detection threshold voltage program step	$V_{\text{SCC}} = V_{\text{SRP}} - V_{\text{SRN}}$ , PROTECTION_CONTROL[RSNS] = 1		22.2		mV
		$V_{\text{SCC}} = V_{\text{SRP}} - V_{\text{SRN}}$ , PROTECTION_CONTROL[RSNS] = 0		11.1		
$V_{\text{SCD1}}$	SCD1 detection threshold voltage range	$V_{\text{SCD1}} = V_{\text{SRP}} - V_{\text{SRN}}$ , PROTECTION_CONTROL[RSNS] = 1	-44.4		-200	mV
		$V_{\text{SCD1}} = V_{\text{SRP}} - V_{\text{SRN}}$ , PROTECTION_CONTROL[RSNS] = 0	-22.2		-100	
$\Delta V_{\text{SCD1}}$	SCD1 detection threshold voltage program step	$V_{\text{SCD1}} = V_{\text{SRP}} - V_{\text{SRN}}$ , PROTECTION_CONTROL[RSNS] = 1		-22.2		mV
		$V_{\text{SCD1}} = V_{\text{SRP}} - V_{\text{SRN}}$ , PROTECTION_CONTROL[RSNS] = 0		-11.1		
$V_{\text{SCD2}}$	SCD2 detection threshold voltage range	$V_{\text{SCD2}} = V_{\text{SRP}} - V_{\text{SRN}}$ , PROTECTION_CONTROL[RSNS] = 1	-44.4		-200	mV
		$V_{\text{SCD2}} = V_{\text{SRP}} - V_{\text{SRN}}$ , PROTECTION_CONTROL[RSNS] = 0	-22.2		-100	
$\Delta V_{\text{SCD2}}$	SCD2 detection threshold voltage program step	$V_{\text{SCD2}} = V_{\text{SRP}} - V_{\text{SRN}}$ , PROTECTION_CONTROL[RSNS] = 1		-22.2		mV
		$V_{\text{SCD2}} = V_{\text{SRP}} - V_{\text{SRN}}$ , PROTECTION_CONTROL[RSNS] = 0		-11.1		

## 7.24 Current Protection Timing

Typical values stated where  $T_A = 25^\circ\text{C}$  and  $V_{CC} = 7.2\text{ V}$ , Min/Max values stated where  $T_A = -40^\circ\text{C}$  to  $85^\circ\text{C}$  and  $V_{CC} = 2.2\text{ V}$  to  $7.6\text{ V}$  (unless otherwise noted)

PARAMETER		TEST CONDITION	MIN	TYP	MAX	UNIT
$t_{\text{OCD}}$	OCD detection delay time		1		31	ms
$\Delta t_{\text{OCD}}$	OCD detection delay time program step			2		ms
$t_{\text{SCC}}$	SCC detection delay time		0		915	$\mu\text{s}$
$\Delta t_{\text{SCC}}$	SCC detection delay time program step			61		$\mu\text{s}$
$t_{\text{SCD1}}$	SCD1 detection delay time	PROTECTION_CONTROL[SCDDx2] = 0	0		915	$\mu\text{s}$
		PROTECTION_CONTROL[SCDDx2] = 1	0		1850	
$\Delta t_{\text{SCD1}}$	SCD1 detection delay time program step	PROTECTION_CONTROL[SCDDx2] = 0		61		$\mu\text{s}$
		PROTECTION_CONTROL[SCDDx2] = 1		121		
$t_{\text{SCD2}}$	SCD2 detection delay time	PROTECTION_CONTROL[SCDDx2] = 0	0		458	$\mu\text{s}$
		PROTECTION_CONTROL[SCDDx2] = 1	0		915	

## Current Protection Timing (continued)

Typical values stated where  $T_A = 25^\circ\text{C}$  and  $V_{CC} = 7.2\text{ V}$ , Min/Max values stated where  $T_A = -40^\circ\text{C}$  to  $85^\circ\text{C}$  and  $V_{CC} = 2.2\text{ V}$  to  $7.6\text{ V}$  (unless otherwise noted)

PARAMETER	TEST CONDITION	MIN	TYP	MAX	UNIT
$\Delta t_{\text{SCD2}}$	SCD2 detection delay time program step	PROTECTION_CONTROL[SCDDx2] = 0			$\mu\text{s}$
		PROTECTION_CONTROL[SCDDx2] = 1			
$t_{\text{DETECT}}$	Current fault detect time	$V_{\text{SRP}} - V_{\text{SRN}} = V_T - 3\text{ mV}$ for OCD, SCD1, and SC2, $V_{\text{SRP}} - V_{\text{SRN}} = V_T + 3\text{ mV}$ for SCC			$\mu\text{s}$
$t_{\text{ACC}}$	Current fault delay time accuracy	Max delay setting			
		-10%		10%	

## 7.25 N-CH FET Drive (CHG, DSG)

Typical values stated where  $T_A = 25^\circ\text{C}$  and  $V_{CC} = 7.2\text{ V}$ , Min/Max values stated where  $T_A = -40^\circ\text{C}$  to  $85^\circ\text{C}$  and  $V_{CC} = 2.2\text{ V}$  to  $7.6\text{ V}$  (unless otherwise noted)

PARAMETER	TEST CONDITION	MIN	TYP	MAX	UNIT	
Output voltage ratio	$\text{Ratio}_{\text{DSG}} = (V_{\text{DSG}} - V_{\text{VC2}})/V_{\text{VC2}}$ , $2.2\text{ V} < V_{\text{VC2}} < 4.07\text{ V}$ , $10\text{ M}\Omega$ between PACK and DSG	2.133	2.333	2.467	—	
	$\text{Ratio}_{\text{CHG}} = (V_{\text{CHG}} - V_{\text{VC2}})/V_{\text{VC2}}$ , $2.2\text{ V} < V_{\text{VC2}} < 4.07\text{ V}$ , $10\text{ M}\Omega$ between BAT and CHG	2.133	2.333	2.467		
$V_{\text{(FETON)}}$	Output voltage, CHG and DSG on	$V_{\text{DSG(ON)}} = V_{\text{DSG}} - V_{\text{VC2}}$ , $V_{\text{VC2}} \geq 4.07\text{ V}$ , $10\text{ M}\Omega$ between PACK and DSG, $V_{\text{VC2}} = 18\text{ V}$	8.75	9.5	10.25	V
		$V_{\text{CHG(ON)}} = V_{\text{CHG}} - V_{\text{VC2}}$ , $V_{\text{VC2}} \geq 4.07\text{ V}$ , $10\text{ M}\Omega$ between VC2 and CHG, $V_{\text{VC2}} = 18\text{ V}$	8.75	9.5	10.25	
$V_{\text{(FETOFF)}}$	Output voltage, CHG and DSG off	$V_{\text{DSG(OFF)}} = V_{\text{DSG}} - V_{\text{PACK}}$ , $10\text{ M}\Omega$ between PACK and DSG	-0.4		0.4	V
		$V_{\text{CHG(OFF)}} = V_{\text{CHG}} - V_{\text{BAT}}$ , $10\text{ M}\Omega$ between VC2 and CHG	-0.4		0.4	
$t_{\text{R}}$	Rise time	$V_{\text{DSG}}$ from 0% to 35% $V_{\text{DSG(ON)(TYP)}}$ , $V_{\text{BAT}} \geq 2.2\text{ V}$ , $C_L = 4.7\text{ nF}$ between DSG and PACK, $5.1\text{ k}\Omega$ between DSG and $C_L$ , $10\text{ M}\Omega$ between PACK and DSG		200	500	$\mu\text{s}$
		$V_{\text{CHG}}$ from 0% to 35% $V_{\text{CHG(ON)(TYP)}}$ , $V_{\text{VC2}} \geq 2.2\text{ V}$ , $C_L = 4.7\text{ nF}$ between CHG and VC2, $5.1\text{ k}\Omega$ between CHG and $C_L$ , $10\text{ M}\Omega$ between VC2 and CHG		200	500	
$t_{\text{F}}$	Fall time	$V_{\text{DSG}}$ from $V_{\text{DSG(ON)(TYP)}}$ to 1 V, $V_{\text{VC2}} \geq 2.2\text{ V}$ , $C_L = 4.7\text{ nF}$ between DSG and PACK, $5.1\text{ k}\Omega$ between DSG and $C_L$ , $10\text{ M}\Omega$ between PACK and DSG		40	300	$\mu\text{s}$
		$V_{\text{CHG}}$ from $V_{\text{CHG(ON)(TYP)}}$ to 1 V, $V_{\text{VC2}} \geq 2.2\text{ V}$ , $C_L = 4.7\text{ nF}$ between CHG and VC2, $5.1\text{ k}\Omega$ between CHG and $C_L$ , $10\text{ M}\Omega$ between VC2 and CHG		40	200	

## 7.26 I<sup>2</sup>C and HDQ Interface I/O

Typical values stated where  $T_A = 25^\circ\text{C}$  and  $V_{CC} = 7.2\text{ V}$ , Min/Max values stated where  $T_A = -40^\circ\text{C}$  to  $85^\circ\text{C}$  and  $V_{CC} = 2.2\text{ V}$  to  $7.6\text{ V}$  (unless otherwise noted)

PARAMETER	TEST CONDITION	MIN	TYP	MAX	UNIT
$V_{\text{IH}}$	Input voltage high	$SCL, SDA, V_{\text{REG}} = 1.8\text{ V}$ (STANDARD and FAST modes)			V
$V_{\text{IL}}$	Input voltage low	$SCL, SDA, V_{\text{REG}} = 1.8\text{ V}$ (STANDARD and FAST modes)			V
$V_{\text{OL}}$	Output low voltage	$SCL, SDA, V_{\text{REG}} = 1.8\text{ V}$ , $I_{\text{OL}} = 3\text{ mA}$ (FAST mode)			V
		$SCL, SDA, V_{\text{REG}} > 2.0\text{ V}$ , $I_{\text{OL}} = 3\text{ mA}$ (STANDARD and FAST modes)			0.4
$C_{\text{IN}}$	Input capacitance			10	pF
$I_{\text{LKG}}$	Input leakage current		1		$\mu\text{A}$
$R_{\text{PD}}$	Pull-down resistance		3.3		k $\Omega$

## 7.27 I<sup>2</sup>C Interface Timing

Typical values stated where  $T_A = 25^\circ\text{C}$  and  $V_{CC} = 7.2\text{ V}$ , Min/Max values stated where  $T_A = -40^\circ\text{C}$  to  $85^\circ\text{C}$  and  $V_{CC} = 2.2\text{ V}$  to  $7.6\text{ V}$  (unless otherwise noted)

			MIN	NOM	MAX	UNIT
$t_R$	Clock rise time	10% to 90%			300	ns
$t_F$	Clock fall time	90% to 10%			300	ns
$t_{HIGH}$	Clock high period		600			ns
$t_{LOW}$	Clock low period		1.3			$\mu\text{s}$
$t_{SU(START)}$	Repeated start setup time		600			ns
$t_{d(START)}$	Start for first falling edge to SCL		600			ns
$t_{SU(DATA)}$	Data setup time		100			ns
$t_{HD(DATA)}$	Data hold time		0			$\mu\text{s}$
$t_{SU(STOP)}$	Stop setup time		600			ns
$t_{BUF}$	Bus free time between stop and start		1.3			$\mu\text{s}$
$f_{SW}$	Clock operating frequency	SLAVE mode, SCL 50% duty cycle			400	kHz

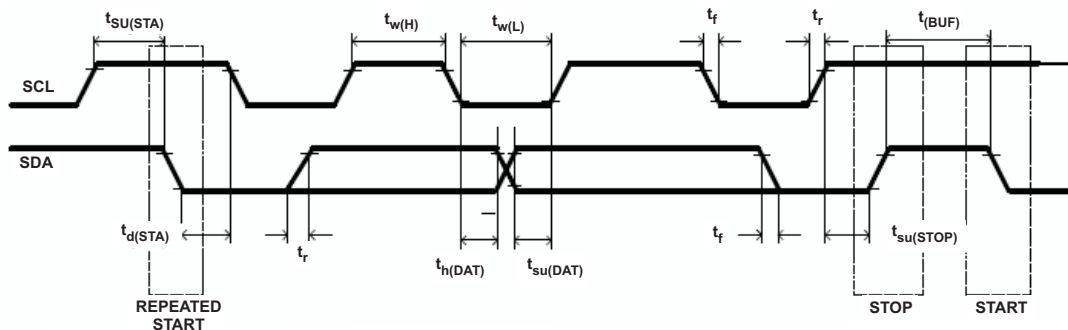


Figure 1. I<sup>2</sup>C Timing

## 7.28 HDQ Interface Timing

$T_A = -40$  to  $+85^\circ\text{C}$ ,  $V_{BAT} = 2.7\text{ V}$  to  $5.5\text{ V}$ ; Typical values stated, where  $T_A = 25^\circ\text{C}$  and  $V_{BAT} = 3.6\text{ V}$  (unless otherwise noted). Capacitance on HDQ is  $10\text{ pF}$  unless otherwise specified

		MIN	NOM	MAX	UNIT
$t_{(CYCH)}$	Cycle time, Host to Slave	190		500	$\mu\text{s}$
$t_{(CYCD)}$	Cycle time, Slave to Host	190	205	250	$\mu\text{s}$
$t_{(HW1)}$	Host sends 1 to Slave	0.5		50	$\mu\text{s}$
$t_{(DW1)}$	Slave sends 1 to Host	32		50	$\mu\text{s}$
$t_{(HW0)}$	Host sends 0 to Slave	86		145	$\mu\text{s}$
$t_{(DW0)}$	Slave sends 0 to Host	80		145	$\mu\text{s}$
$t_{(RSPS)}$	Response time, Slave to Host	190		950	$\mu\text{s}$
$t_{(B)}$	Break Time	190			$\mu\text{s}$
$t_{(BR)}$	Break Recovery Time	40			$\mu\text{s}$
$t_{(R)}$	HDQ Line Rise Time to Logic 1 (1.2 V)			950	ns
$t_{(RST)}$	HDQ Reset	1.8		2.2	s

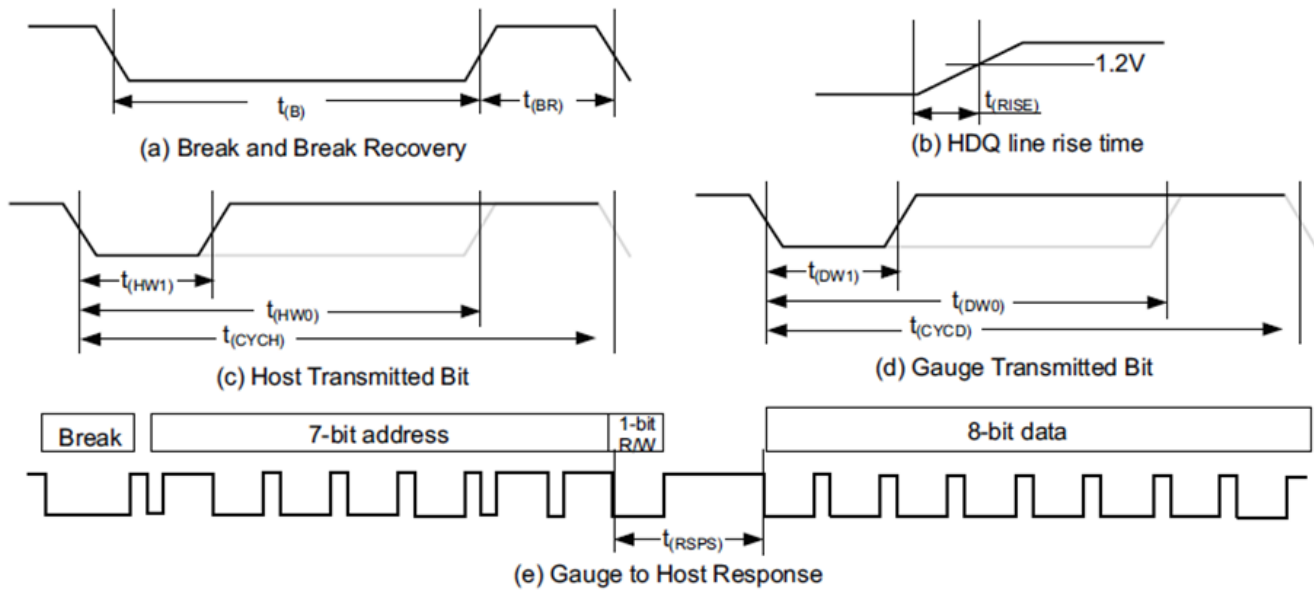


Figure 2. HDQ Timing

## 7.29 Typical Characteristics

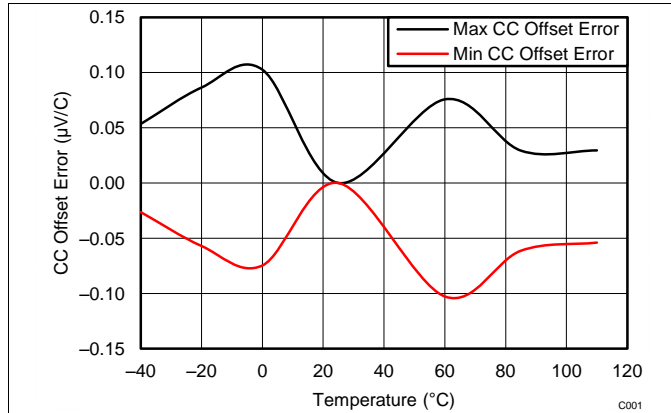


Figure 3. CC Offset Error vs. Temperature

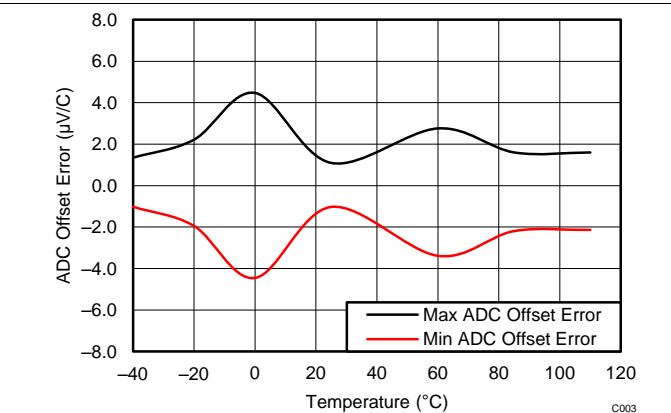


Figure 4. ADC Offset Error vs. Temperature

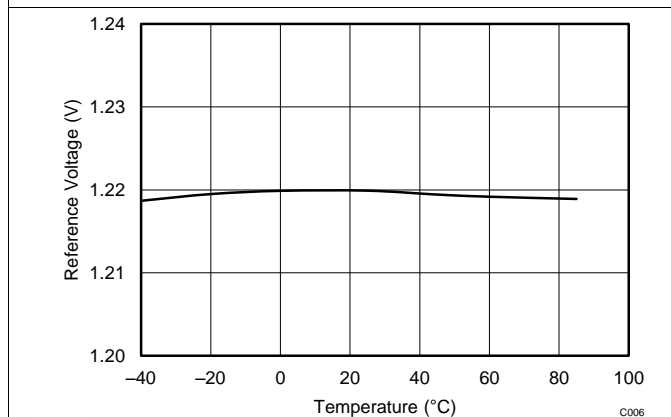


Figure 5. Reference Voltage vs. Temperature

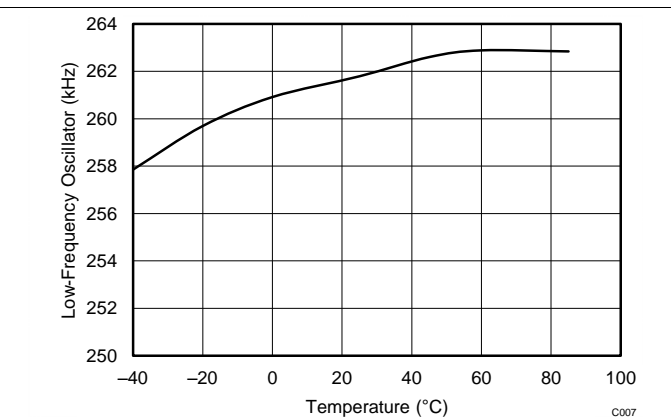


Figure 6. Low-Frequency Oscillator vs. Temperature

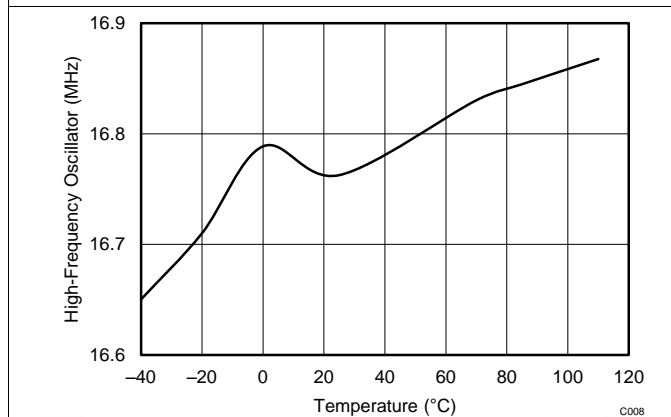


Figure 7. High-Frequency Oscillator vs. Temperature

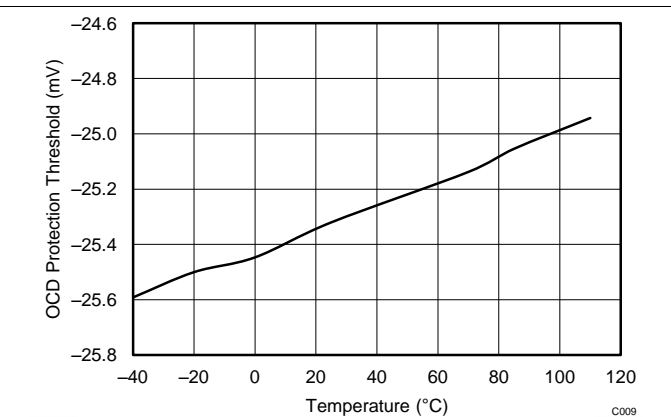
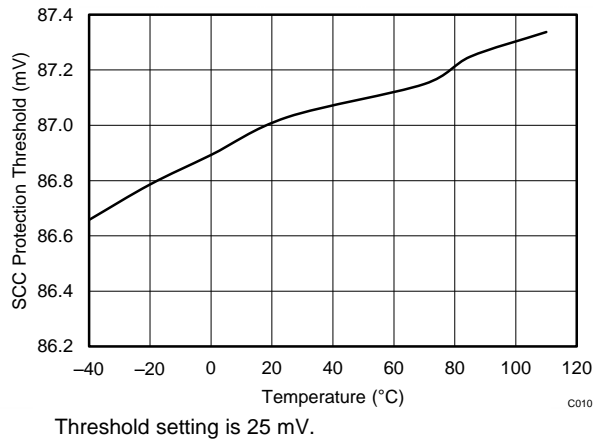
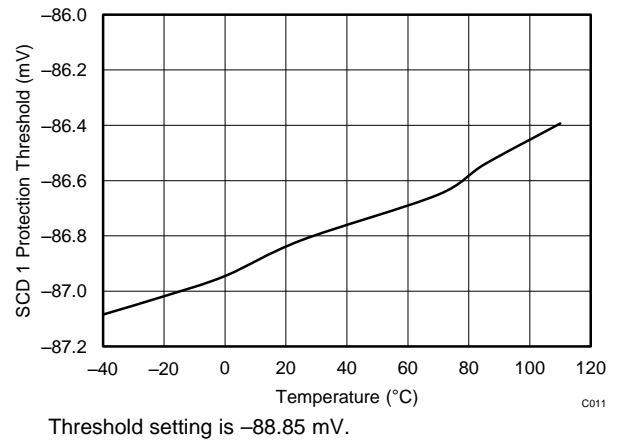


Figure 8. Overcurrent Discharge Protection Threshold vs. Temperature  
Threshold setting is 25 mV.

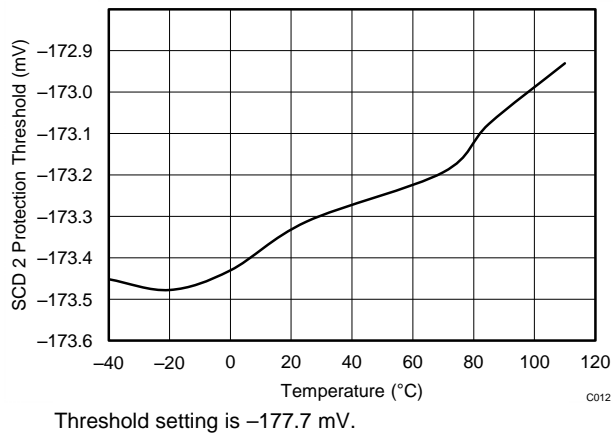
**Typical Characteristics (continued)**



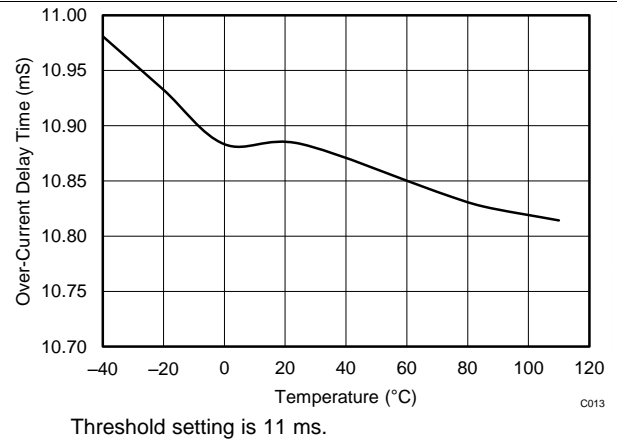
**Figure 9. Short Circuit Charge Protection Threshold vs. Temperature**



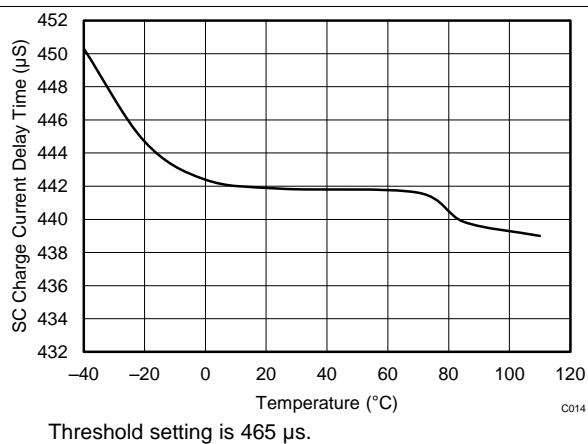
**Figure 10. Short Circuit Discharge 1 Protection Threshold vs. Temperature**



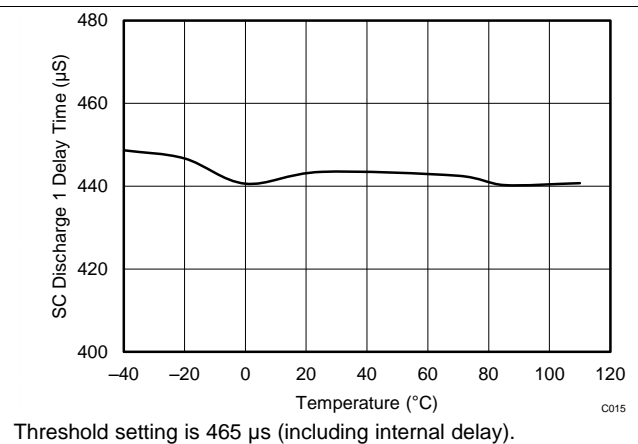
**Figure 11. Short Circuit Discharge 2 Protection Threshold vs. Temperature**



**Figure 12. Overcurrent Delay Time vs. Temperature**

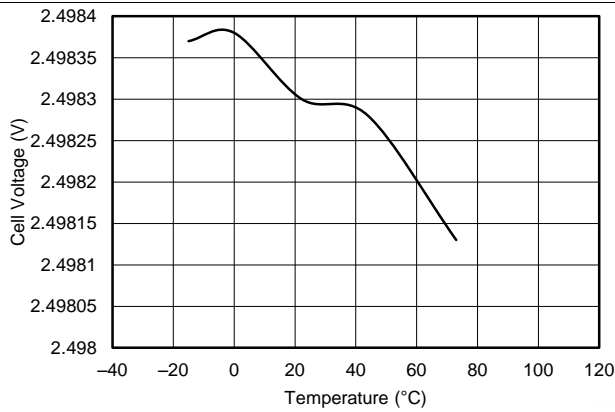


**Figure 13. Short Circuit Charge Current Delay Time vs. Temperature**

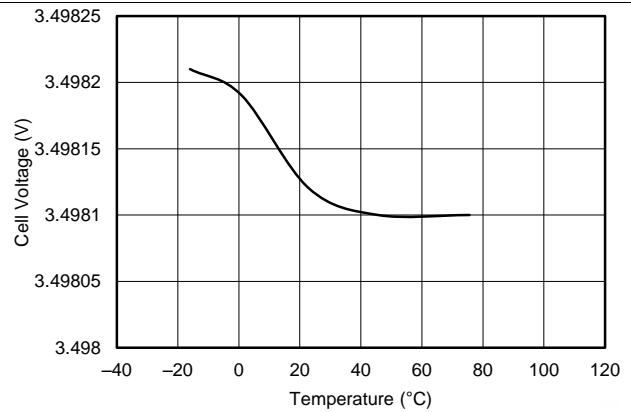


**Figure 14. Short Circuit Discharge 1 Delay Time vs. Temperature**

**Typical Characteristics (continued)**

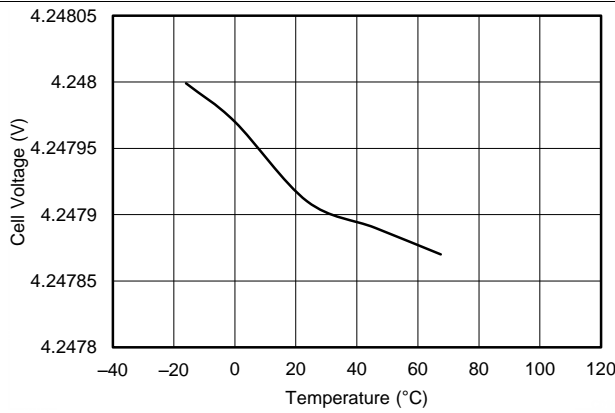


**Figure 15.  $V_{CELL}$  Measurement at 2.5-V vs. Temperature**



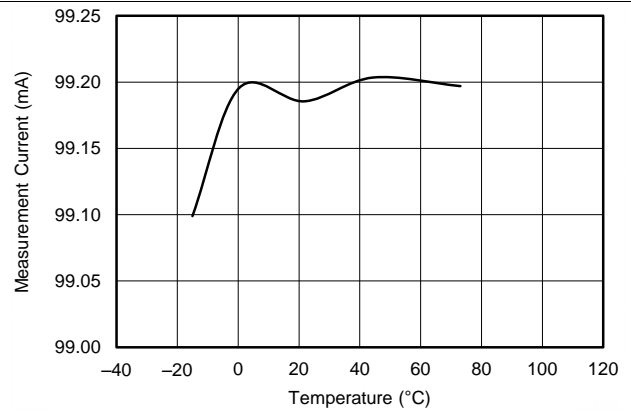
This is the  $V_{CELL}$  average for single cell.

**Figure 16.  $V_{CELL}$  Measurement at 3.5-V vs. Temperature**



This is the  $V_{CELL}$  average for single cell.

**Figure 17.  $V_{CELL}$  Measurement at 4.25-V vs. Temperature**



$I_{SET} = 100 \text{ mA}$

**Figure 18.  $I$  Measured vs. Temperature**



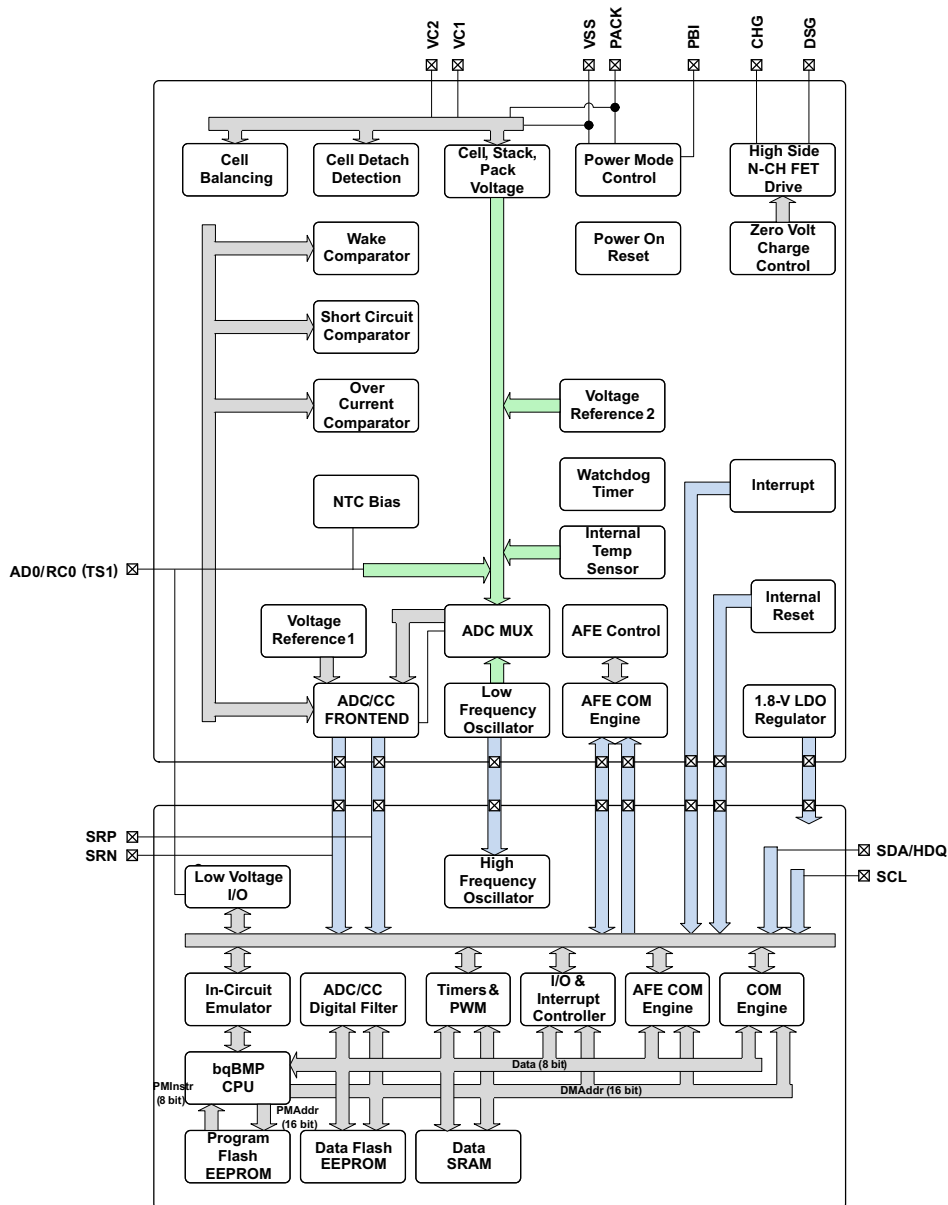
## 8 Detailed Description

### 8.1 Overview

The bq78z100 gas gauge is a fully integrated battery manager that employs flash-based firmware and integrated hardware protection to provide a complete solution for battery-stack architectures composed of 1-series or 2-series cells. The bq78z100 device interfaces with a host system via I<sup>2</sup>C or HDQ protocols. High-performance, integrated analog peripherals enable support for a sense resistor down to 1 mΩ and simultaneous current/voltage data conversion for instant power calculations. The following sections detail all of the major component blocks included as part of the bq78z100 device.

### 8.2 Functional Block Diagram

The *Functional Block Diagram* shows the analog and digital peripheral content in the bq78z100 device.



## 8.3 Feature Description

### 8.3.1 Battery Parameter Measurements

The bq78z100 device measures cell voltage and current simultaneously, and also measures temperature to calculate the information related to remaining capacity, full charge capacity, state-of-health, and other gauging parameters.

#### 8.3.1.1 bq78z100 Processor

The bq78z100 device uses a custom TI-proprietary processor design that features a Harvard architecture and operates at frequencies up to 4.2 MHz. Using an adaptive, three-stage instruction pipeline, the bq78z100 processor supports variable instruction length of 8, 16, or 24 bits.

### 8.3.2 Coulomb Counter (CC)

The first ADC is an integrating converter designed specifically for coulomb counting. The converter resolution is a function of its full-scale range and number of bits, yielding a 3.74- $\mu$ V resolution.

### 8.3.3 CC Digital Filter

The CC digital filter generates a 16-bit conversion value from the delta-sigma CC front-end. Its FIR filter uses the LFO clock output, which allows it to stop the HFO clock during conversions. New conversions are available every 250 ms while CCTL[CC\_ON] = 1. Proper use of this peripheral requires turning on the CC modulator in the AFE.

### 8.3.4 ADC Multiplexer

The ADC multiplexer provides selectable connections to the VCx inputs, TS1 inputs, internal temperature sensor, internal reference voltages, internal 1.8-V regulator, PACK input, and VSS ground reference input. In addition, the multiplexer can independently enable the TS1 input connection to the internal thermistor biasing circuitry, and also enables the user to short the multiplexer inputs for test and calibration purposes.

### 8.3.5 Analog-to-Digital Converter (ADC)

The second ADC is a 16-bit delta-sigma converter designed for general-purpose measurements. The ADC automatically scales the input voltage range during sampling based on channel selection. The converter resolution is a function of its full-scale range and number of bits, yielding a 38- $\mu$ V resolution. The default conversion time of the ADC is 31.25 ms, but is user-configurable down to 1.95 ms. Decreasing the conversion time presents a tradeoff between conversion speed and accuracy, as the resolution decreases for faster conversion times.

### 8.3.6 ADC Digital Filter

The ADC digital filter generates a 24-bit conversion result from the delta-sigma ADC front end. Its FIR filter uses the LFO clock, which allows it to stop the HFO clock during conversions. The ADC digital filter is capable of providing two 24-bit results: one result from the delta-sigma ADC front-end and a second synchronous result from the delta-sigma CC front-end.

### 8.3.7 Internal Temperature Sensor

An internal temperature sensor is available on the bq78z100 device to reduce the cost, power, and size of the external components necessary to measure temperature. It is available for connection to the ADC using the multiplexer, and is ideal for quickly determining pack temperature under a variety of operating conditions.

### 8.3.8 External Temperature Sensor Support

The TS1 input is enabled with an internal 18-k $\Omega$  (Typ.) linearization pull-up resistor to support the use of a 10-k $\Omega$  (25°C) NTC external thermistor, such as the Semitec 103AT-2. The NTC thermistor should be connected between VSS and the individual TS1 pin. The analog measurement is then taken via the ADC through its input multiplexer. If a different thermistor type is required, then changes to configurations may be required.

## Feature Description (continued)

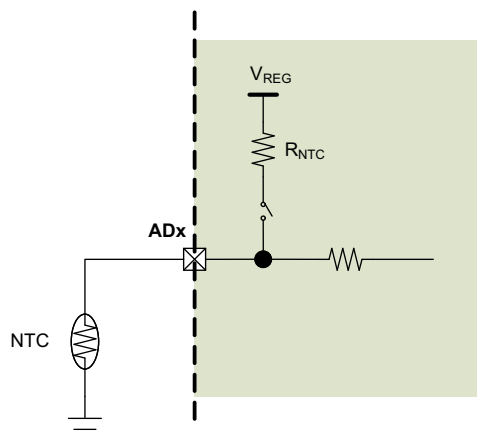


Figure 19. External Thermistor Biasing

### 8.3.9 Power Supply Control

The bq78z100 device manages its supply voltage dynamically according to operating conditions. When  $V_{VC2} > V_{SWITCHOVER-} + V_{HYS}$ , the AFE connects an internal switch to BAT and uses this pin to supply power to its internal 1.8-V LDO, which subsequently powers all device logic and flash operations. Once  $VC2$  decreases to  $V_{VC2} < V_{SWITCHOVER-}$ , the AFE disconnects its internal switch from VC2 and connects another switch to PACK, allowing sourcing of power from a charger (if present). An external capacitor connected to PBI provides a momentary supply voltage to help guard against system brownouts due to transient short-circuit or overload events that pull  $VC2$  below  $V_{SWITCHOVER-}$ .

### 8.3.10 Power-On Reset

In the event of a power-cycle, the bq78z100 AFE holds its internal RESET output pin high for  $t_{RST}$  duration to allow its internal 1.8-V LDO and LFO to stabilize before running the AGG. The AFE enters power-on reset when the voltage at  $V_{REG}$  falls below  $V_{REGIT-}$  and exits reset when  $V_{REG}$  rises above  $V_{REGIT-} + V_{HYS}$  for  $t_{RST}$  time. After  $t_{RST}$ , the bq78z100 AGG will write its trim values to the AFE.

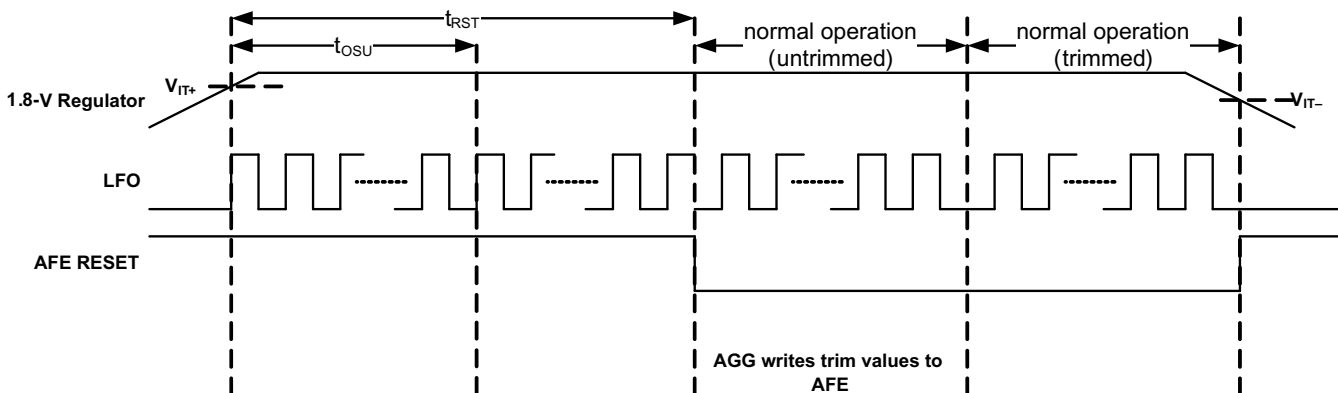


Figure 20. POR Timing Diagram

### 8.3.11 Bus Communication Interface

The bq78z100 device has an I<sup>2</sup>C bus communication interface by default, but can be configured to use the single-wire HDQ interface. Devices for end applications that operate in HDQ mode are intended to be kept in default I<sup>2</sup>C mode as they go through pack manufacturer production line so that they can be configured and tested at the PCB level before they are converted to HDQ mode.

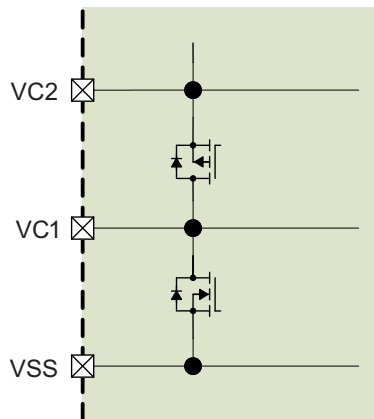
## Feature Description (continued)

### CAUTION

If the device is configured as a single-master architecture (an application processor) and an occasional NACK is detected in the operation, the master can resend the transaction. However, in a multi-master architecture, an incorrect ACK leading to accidental loss of bus arbitration can cause a master to wait incorrectly for another master to clear the bus. If this master does not get a bus-free signal, then it must have in place a method to look for the bus and assume it is free after some period of time. Also, if possible, set the clock speed to be 100 kHz or less to significantly reduce the issue described above for multi-mode operation.

### 8.3.12 Cell Balancing Support

The integrated cell balancing FETs included in the bq78z100 device enable the AFE to bypass cell current around a given cell or numerous cells to effectively balance the entire battery stack. External series resistors placed between the cell connections and the VCx input pins set the balancing current magnitude. The cell balancing circuitry can be enabled or disabled via the **CELL\_BAL\_DET[CB2, CB1]** control register. Series input resistors between 100 Ω and 1 kΩ are recommended for effective cell balancing.



**Figure 21. Internal Cell Balancing**

### 8.3.13 N-Channel Protection FET Drive

The bq78z100 device controls two external N-Channel MOSFETs in a back-to-back configuration for battery protection. The charge (CHG) and discharge (DSG) FETs are automatically disabled if a safety fault (AOLD, ASSC, ASCD, SOV) is detected, and can also be manually turned off using **AFE\_CONTROL[CHGEN, DSGEN]** = 0, 0. When the gate drive is disabled, an internal circuit discharges CHG to VC2 and DSG to PACK.

### 8.3.14 Low Frequency Oscillator

The bq78z100 AFE includes a low frequency oscillator (LFO) running at 262.144 kHz. The AFE monitors the LFO frequency and indicates a failure via **LATCH\_STATUS[LFO]** if the output frequency is much lower than normal.

### 8.3.15 High Frequency Oscillator

The bq78z100 AGG includes a high frequency oscillator (HFO) running at 16.78 MHz. It is synthesized from the LFO output and scaled down to 8.388 MHz with 50% duty cycle.

### 8.3.16 1.8-V Low Dropout Regulator

The bq78z100 AFE contains an integrated 1.8-V LDO that provides regulated supply voltage for the device CPU and internal digital logic.

## Feature Description (continued)

### 8.3.17 Internal Voltage References

The bq78z100 AFE provides two internal voltage references with  $V_{REF1}$ , used by the ADC and CC, while  $V_{REF2}$  is used by the LDO, LFO, current wake comparator, and OCD/SCC/SCD1/SCD2 current protection circuitry.

### 8.3.18 Overcurrent in Discharge Protection

The overcurrent in discharge (OCD) function detects abnormally high current in the discharge direction. The overload in discharge threshold and delay time are configurable via the `OCD_CONTROL` register. The thresholds and timing can be fine-tuned even further based on a sense resistor with lower resistance or wider tolerance via the `PROTECTION_CONTROL` register. The detection circuit also incorporates a filtered delay before disabling the CHG and DSG FETs. When an OCD event occurs, the **`LATCH_STATUS[OCD]`** bit is set to 1 and is latched until it is cleared and the fault condition has been removed.

### 8.3.19 Short-Circuit Current in Charge Protection

The short-circuit current in charge (SCC) function detects catastrophic current conditions in the charge direction. The short-circuit in charge threshold and delay time are configurable via the `SCC_CONTROL` register. The thresholds and timing can be fine-tuned even further based on a sense resistor with lower resistance or wider tolerance via the `PROTECTION_CONTROL` register. The detection circuit also incorporates a blanking delay before disabling the CHG and DSG FETs. When an SCC event occurs, the **`LATCH_STATUS[SCC]`** bit is set to 1 and is latched until it is cleared and the fault condition has been removed.

### 8.3.20 Short-Circuit Current in Discharge 1 and 2 Protection

The short-circuit current in discharge (SCD) function detects catastrophic current conditions in the discharge direction. The short-circuit in discharge thresholds and delay times are configurable via the `SCD1_CONTROL` and `SCD2_CONTROL` registers. The thresholds and timing can be fine-tuned even further based on a sense resistor with lower resistance or wider tolerance via the `PROTECTION_CONTROL` register. The detection circuit also incorporates a blanking delay before disabling the CHG and DSG FETs. When an SCD event occurs, the **`LATCH_STATUS[SCD1]`** or **`LATCH_STATUS[SCD2]`** bit is set to 1 and is latched until it is cleared and the fault condition has been removed.

### 8.3.21 Primary Protection Features

The bq78z100 gas gauge supports the following battery and system level protection features, which can be configured using firmware:

- Cell Undervoltage Protection
- Cell Overvoltage Protection
- Overcurrent in CHARGE Mode Protection
- Overcurrent in DISCHARGE Mode Protection
- Overload in DISCHARGE Mode Protection
- Short Circuit in CHARGE Mode Protection
- Overtemperature in CHARGE Mode Protection
- Overtemperature in DISCHARGE Mode Protection
- Precharge Timeout Protection
- Fast Charge Timeout Protection

### 8.3.22 Gas Gauging

This device uses the Impedance Track technology to measure and determine the available charge in battery cells. The accuracy achieved using this method is better than 1% error over the lifetime of the battery. There is no full charge/discharge learning cycle required. See the *Theory and Implementation of Impedance Track Battery Fuel-Gauging Algorithm Application Report (SLUA364B)* for further details.

## Feature Description (continued)

### 8.3.23 Charge Control Features

This device supports charge control features, such as:

- Reports charging voltage and charging current based on the active temperature range—JEITA temperature ranges T1, T2, T3, T4, T5, and T6
- Provides more complex charging profiles, including sub-ranges within a standard temperature range
- Reports the appropriate charging current required for constant current charging and the appropriate charging voltage needed for constant voltage charging to a smart charger, using the bus communication interface
- Selects the chemical state-of-charge of each battery cell using the Impedance Track method, and reduces the voltage difference between cells when cell balancing multiple cells in a series
- Provides pre-charging/zero-volt charging
- Employs charge inhibit and charge suspend if battery pack temperature is out of programmed range
- Reports charging faults and indicates charge status via charge and discharge alarms

### 8.3.24 Authentication

This device supports security by:

- Authentication by the host using the SHA-1 method
- The gas gauge requires SHA-1 authentication before the device can be unsealed or allow full access.

## 8.4 Device Functional Modes

This device supports three modes, but the current consumption varies, based on firmware control of certain functions and modes of operation:

- **NORMAL mode:** In this mode, the device performs measurements, calculations, protections, and data updates every 250-ms intervals. Between these intervals, the device is operating in a reduced power stage to minimize total average current consumption.
- **SLEEP mode:** In this mode, the device performs measurements, calculations, protections, and data updates in adjustable time intervals. Between these intervals, the device is operating in a reduced power stage to minimize total average current consumption.
- **SHUTDOWN mode:** The device is completely disabled.

### 8.4.1 Lifetime Logging Features

The device supports data logging of several key parameters for warranty and analysis:

- Maximum and Minimum Cell Temperature
- Maximum Current in CHARGE or DISCHARGE Mode
- Maximum and Minimum Cell Voltages

### 8.4.2 Configuration

The device supports accurate data measurements and data logging of several key parameters.

#### 8.4.2.1 Coulomb Counting

The device uses an integrating delta-sigma analog-to-digital converter (ADC) for current measurement. The ADC measures charge/discharge flow of the battery by measuring the voltage across a very small external sense resistor. The integrating ADC measures a bipolar signal from a range of  $-100\text{ mV}$  to  $100\text{ mV}$ , with a positive value when  $V_{(SRP)} - V_{(SRN)}$ , indicating charge current and a negative value indicating discharge current. The integration method uses a continuous timer and internal counter, which has a rate of  $0.65\text{ nVh}$ .

#### 8.4.2.2 Cell Voltage Measurements

The bq78z100 measures the individual cell voltages at 250-ms intervals using an ADC. This measured value is internally scaled for the ADC and is calibrated to reduce any errors due to offsets. This data is also used for calculating the impedance of the individual cell for Impedance Track gas gauging.

## Device Functional Modes (continued)

### 8.4.2.3 Current Measurements

The current measurement is performed by measuring the voltage drop across the external sense resistor (1 mΩ to 3 mΩ) and the polarity of the differential voltage determines if the cell is in the CHARGE or DISCHARGE mode.

### 8.4.2.4 Auto Calibration

The auto-calibration feature helps to cancel any voltage offset across the SRP and SRN pins for accurate measurement of the cell voltage, charge/discharge current, and thermistor temperature. The auto-calibration is performed when there is no communication activity for a minimum of 5 s on the bus lines.

### 8.4.2.5 Temperature Measurements

This device has an internal sensor for on-die temperature measurements, and the ability to support external temperature measurements via the external NTC on the TS1 pin. These two measurements are individually enabled and configured.

## 9 Applications and Implementation

### 9.1 Application Information

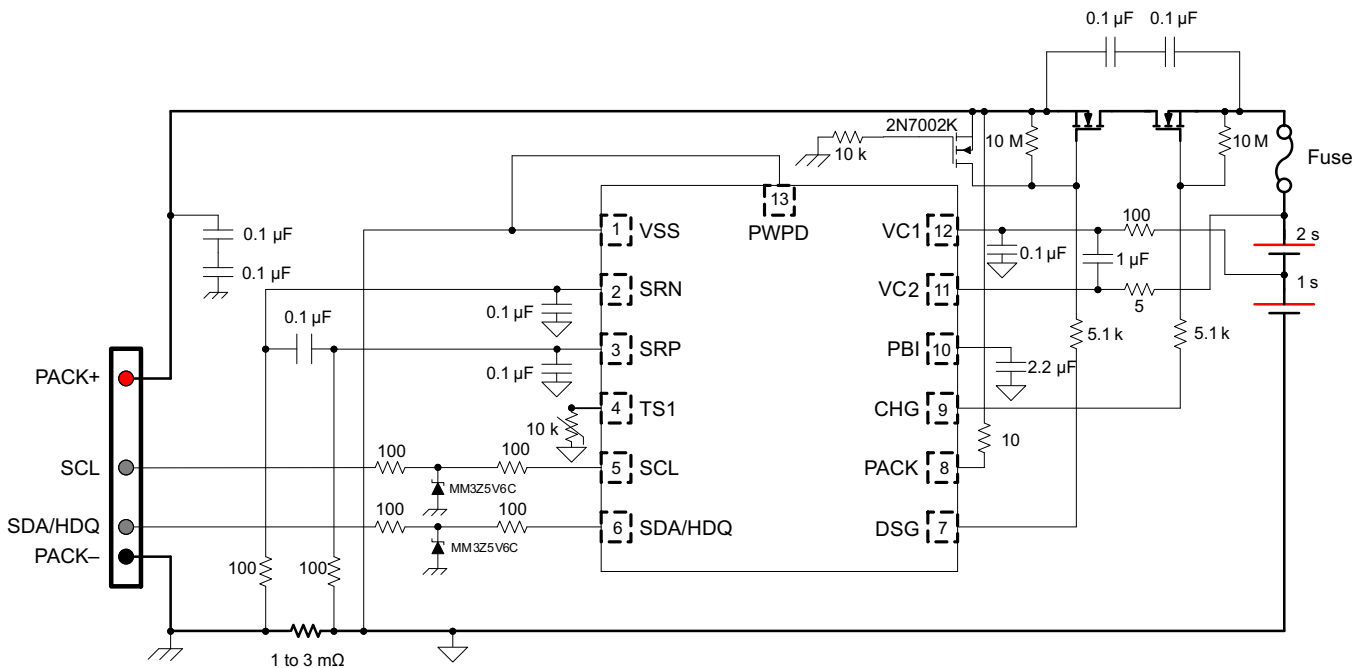
#### NOTE

Information in the following applications sections is not part of the TI component specification, and TI does not warrant its accuracy or completeness. TI's customers are responsible for determining suitability of components for their purposes. Customers should validate and test their design implementation to confirm system functionality.

The bq78z100 gas gauge is a primary protection device that can be used with a 1-series or 2-series Li-Ion/Li Polymer battery pack. To implement and design a comprehensive set of parameters for a specific battery pack, the user needs Battery Management Studio (bqSTUDIO), which is a graphical user-interface tool installed on a PC during development. The firmware installed in the product has default values, which are summarized in the *bq78z100 Technical Reference Manual (SLUUB63)* for this product. Using the bqSTUDIO tool, these default values can be changed to cater to specific application requirements during development once the system parameters, such as fault trigger thresholds for protection, enable/disable of certain features for operation, configuration of cells, chemistry that best matches the cell used, and more are known. This data can be referred to as the "golden image."

### 9.2 Typical Applications

The following is the bq78z100 application schematic for the 2-series configuration.



Note: The input filter capacitors of 0.1 µF for the SRN and SRP pins must be located near the pins of the device.

**Figure 22. bq78z100 2-Series Cell Typical Implementation**

#### 9.2.1 Design Requirements (Default)

Design Parameter	Example
Cell Configuration	2s1p (2-series with 1 Parallel)
Design Capacity	4400 mAh
Device Chemistry	100 (LiCoO <sub>2</sub> /graphitized carbon)



## Typical Applications (continued)

Design Parameter	Example
Cell Overvoltage at Standard Temperature	4300 mV
Cell Undervoltage	2500 mV
Shutdown Voltage	2300 mV
Overcurrent in CHARGE Mode	6000 mA
Overcurrent in DISCHARGE Mode	–6000 mA
Short Circuit in CHARGE Mode	0.1 V/Rsense across SRP, SRN
Short Circuit in DISCHARGE 1 Mode	0.1 V/Rsense across SRP, SRN
Safety Over Voltage	4500 mV
Cell Balancing	Disabled
Internal and External Temperature Sensor	Enabled
Under Temperature Charging	0°C
Under Temperature Discharging	0°C
BROADCAST Mode	Enabled
I <sup>2</sup> C Interface	Enabled

### 9.2.2 Detailed Design Procedure

#### 9.2.2.1 Setting Design Parameters

For the firmware settings needed for the design requirements, refer to the *bq78z100 Technical Reference Manual (SLUUB63)*.

- To set the 2s1p battery pack, go to data flash **Configuration: DA Configuration** register's bit 0 (CC0) = 1.
- To set design capacity, set the data flash value to 4400 in the **Gas Gauging: Design: Design Capacity** register.
- To set device chemistry, go to data flash **SBS Configuration: Data: Device Chemistry**. The bqStudio software automatically populates the correct chemistry identification. This selection is derived from using the bqCHEM feature in the tools and choosing the option that matches the device chemistry from the list.
- To protect against cell overvoltage, set the data flash value to 4300 in **Protections: COV: Standard Temp**.
- To protect against cell undervoltage, set the data flash value to 2500 in the **Protections: CUV** register.
- To set the shutdown voltage to prevent further pack depletion due to low pack voltage, program **Power: Shutdown: Shutdown** voltage = 2300.
- To protect against large charging currents when the AC adapter is attached, set the data flash value to 6000 in the **Protections: OCC: Threshold** register.
- To protect against large discharging currents when heavy loads are attached, set the data flash value to –6000 in the **Protections: OCD: Threshold** register.
- Program a short circuit delay timer and threshold setting to enable the operating the system for large short transient current pulses. These two parameters are under **Protections: ASCC: Threshold** = 100 for charging current. The discharge current setting is Protections: ASCD:Threshold = –100 mV.
- To prevent the cells from overcharging and adding a second level of safety, there is a register setting that will shut down the device if any of the cells voltage measurement is greater than the Safety Over Voltage setting for greater than the delay time. Set this data flash value to 4500 in **Permanent Fail: SOV: Threshold**.
- To disable the cell balancing feature, set the data flash value to 0 in **Settings: Configuration: Balancing Configuration: bit 0 (CB)**.
- To enable the internal temperature and the external temperature sensors: Set **Settings: Configuration: Temperature Enable: Bit 0 (TSInt)** = 1 for the internal sensor; set Bit 1 (TS1) = 1 for the external sensor.
- To prevent charging of the battery pack if the temperature falls below 0°C, set **Protections: UTC:Threshold** = 0.
- To prevent discharging of the battery pack if the temperature falls below 0°C, set **Protections: UTD:Threshold** = 0.

Each parameter listed for fault trigger thresholds has a delay timer setting associated for any noise filtering. These values, along with the trigger thresholds for fault detection, may be changed based upon the application requirements using the data flash settings in the appropriate register stated in the *bq78z100 Technical Reference Manual (SLUUB63)*.

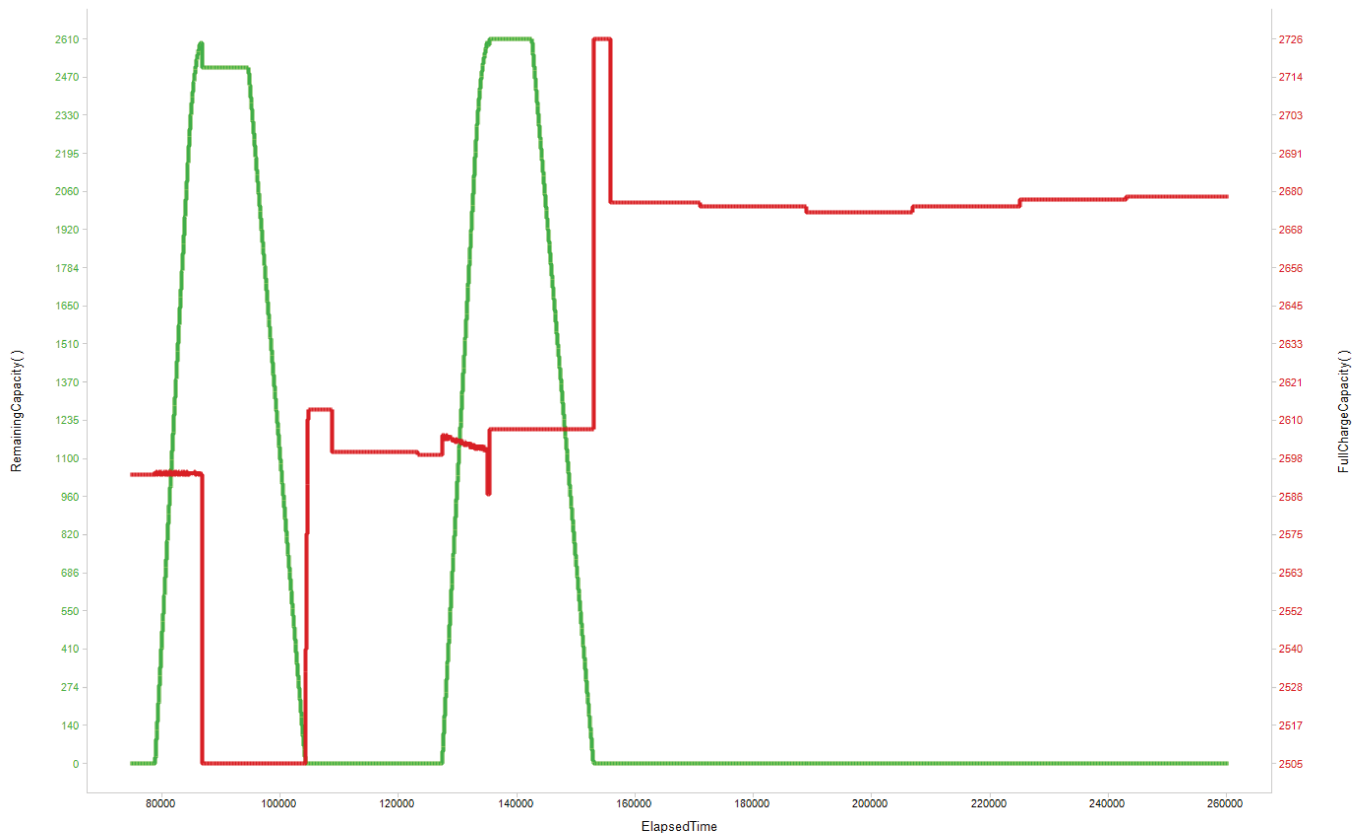
### 9.2.3 Calibration Process

The calibration of Current, Voltage, and Temperature readings is accessible by writing 0xF081 or 0xF082 to *ManufacturerAccess()*. A detailed procedure is included in the *bq78z100 Technical Reference Manual (SLUUB63)* in the *Calibration* section. The description allows for calibration of Cell Voltage Measurement Offset, Battery Voltage, Pack Voltage, Current Calibration, Coulomb Counter Offset, PCB Offset, CC Gain/Capacity Gain, and Temperature Measurement for both internal and external sensors.

### 9.2.4 Gauging Data Updates

When a battery pack enabled with the bq78z100 is first cycled, the value of *FullChargeCapacity()* updates several times. [Figure 23](#) shows *RemainingCapacity()* and *FullChargeCapacity()*, and where those updates occur. As part of the Impedance Track algorithm, it is expected that *FullChargeCapacity()* may update at the end of charge, at the end of discharge, and at rest.

#### 9.2.4.1 Application Curve



**Figure 23. Gauging Data Updates**

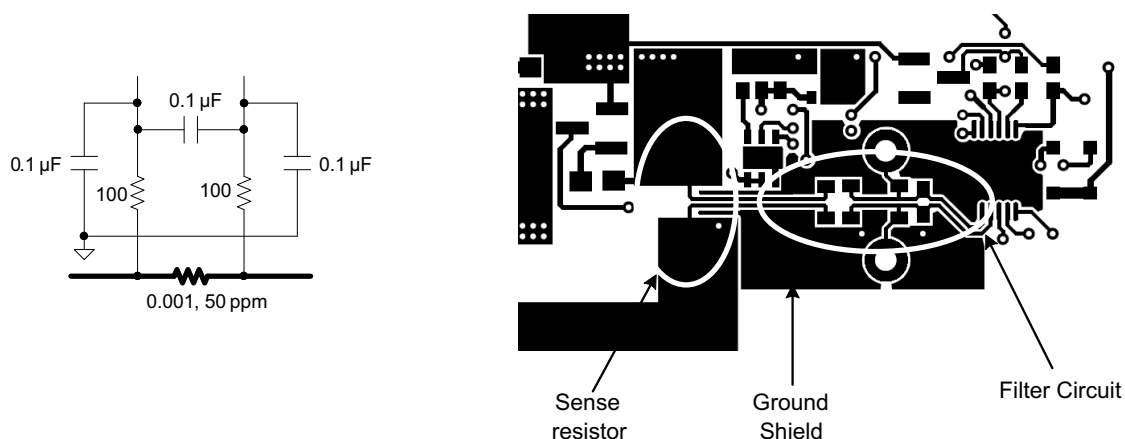
## 10 Power Supply Requirements

There are two inputs for this device, the PACK input and VC2. The PACK input can be an unregulated input from a typical AC adapter. This input should always be greater than the maximum voltage associated with the number of series cells configured. The input voltage for the VC2 pin will have a minimum of 2.2 V to a maximum of 26 V with the recommended external RC filter.

## 11 Layout

### 11.1 Layout Guidelines

- The layout for the high-current path begins at the PACK+ pin of the battery pack. As charge current travels through the pack, it finds its way through protection FETs, a chemical fuse, the lithium-ion cells and cell connections, and the sense resistor, and then returns to the PACK– pin. In addition, some components are placed across the PACK+ and PACK– pins to reduce effects from electrostatic discharge.
- The N-channel charge and discharge FETs must be selected for a given application. Most portable battery applications are a good option for the CSD16412Q5A. These FETs are rated at 14-A, 25-V device with  $R_{ds(on)}$  of 11 m $\Omega$  when the gate drive voltage is 10 V. The gates of all protection FETs are pulled to the source with a high-value resistor between the gate and source to ensure they are turned off if the gate drive is open. The capacitors (both 0.1  $\mu$ F values) placed across the FETs are to help protect the FETs during an ESD event. The use of two devices ensures normal operation if one of them becomes shorted. For effective ESD protection, the copper trace inductance of the capacitor leads must be designed to be as short and wide as possible. Ensure that the voltage rating of both these capacitors are adequate to hold off the applied voltage if one of the capacitors becomes shorted.
- The quality of the Kelvin connections at the sense resistor is critical. The sense resistor must have a temperature coefficient no greater than 50 ppm in order to minimize current measurement drift with temperature. Choose the value of the sense resistor to correspond to the available overcurrent and short-circuit ranges of the bq78z100. Select the smallest value possible in order to minimize the negative voltage generated on the bq78z100 VSS node(s) during a short circuit. This pin has an absolute minimum of  $-0.3$  V. Parallel resistors can be used as long as good Kelvin sensing is ensured. The device is designed to support a 1-m $\Omega$  to 3-m $\Omega$  sense resistor.
- A pair of series 0.1- $\mu$ F ceramic capacitors is placed across the PACK+ and PACK– pins to help in the mitigation of external electrostatic discharges. The two devices in series ensure continued operation of the pack if one of the capacitors becomes shorted. Optionally, a transorb such as the SMBJ2A can be placed across the pins to further improve ESD immunity.
- In reference to the gas gauge circuit the following features require attention for component placement and layout; Differential Low-Pass Filter, I<sup>2</sup>C communication and PBI (Power Backup Input).
- The bq78z100 uses an integrating delta-sigma ADC for current measurements. Add a 100- $\Omega$  resistor from the sense resistor to the SRP and SRN inputs of the device. Place a 0.1- $\mu$ F filter capacitor across the SRP and SRN inputs. Optional 0.1- $\mu$ F filter capacitors can be added for additional noise filtering for each sense input pin to ground, if required for your circuit. Place all filter components as close as possible to the device. Route the traces from the sense resistor in parallel to the filter circuit. Adding a ground plane around the filter network can add additional noise immunity.



**Figure 24. bq78z100 Differential Filter**

- The bq78z100 has an internal LDO that is internally compensated and does not require an external decoupling capacitor. The PBI pin is used as a power supply backup input pin, providing power during brief transient power outages. A standard 2.2- $\mu$ F ceramic capacitor is connected from the PBI pin to ground, as shown in application example.
- The I<sup>2</sup>C clock and data pins have integrated high-voltage ESD protection circuits; however, adding a Zener

## Layout Guidelines (continued)

diode and series resistor provides more robust ESD performance. The I<sup>2</sup>C clock and data lines have an internal pull-down. When the gas gauge senses that both lines are low (such as during removal of the pack), the device performs auto-offset calibration and then goes into SLEEP mode to conserve power.

## 11.2 Layout Example

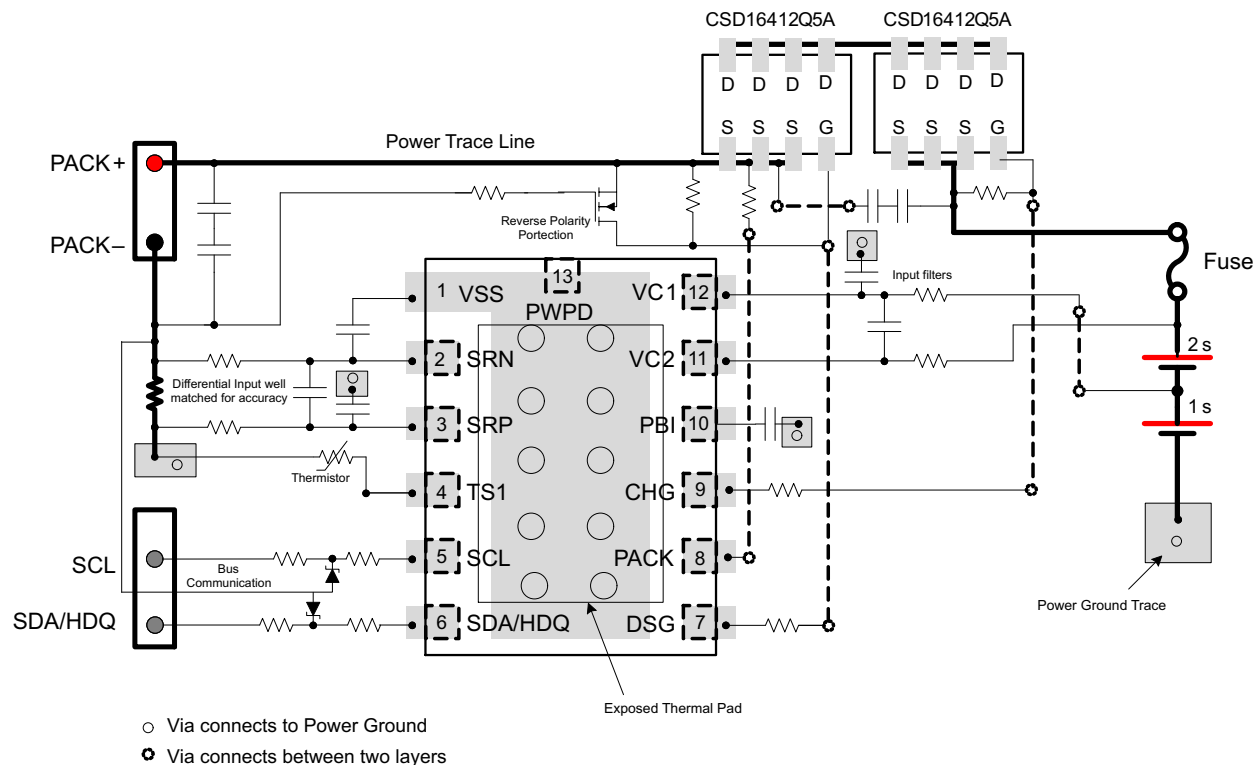


Figure 25. bq78z100 Board Layout

## 12 Device and Documentation Support

### 12.1 Documentation Support

See the *bq78z100 Technical Reference Manual* ([SLUUB63](#)) for more information.

### 12.2 Community Resources

The following links connect to TI community resources. Linked contents are provided "AS IS" by the respective contributors. They do not constitute TI specifications and do not necessarily reflect TI's views; see TI's [Terms of Use](#).

**TI E2E™ Online Community** *TI's Engineer-to-Engineer (E2E) Community*. Created to foster collaboration among engineers. At [e2e.ti.com](http://e2e.ti.com), you can ask questions, share knowledge, explore ideas and help solve problems with fellow engineers.

**Design Support** *TI's Design Support* Quickly find helpful E2E forums along with design support tools and contact information for technical support.

### 12.3 Trademarks

Impedance Track, E2E are trademarks of Texas Instruments. All other trademarks are the property of their respective owners.

### 12.4 Electrostatic Discharge Caution



This integrated circuit can be damaged by ESD. Texas Instruments recommends that all integrated circuits be handled with appropriate precautions. Failure to observe proper handling and installation procedures can cause damage.

ESD damage can range from subtle performance degradation to complete device failure. Precision integrated circuits may be more susceptible to damage because very small parametric changes could cause the device not to meet its published specifications.

### 12.5 Glossary

[SLYZ022](#) — *TI Glossary*.

This glossary lists and explains terms, acronyms, and definitions.

### **13 Mechanical, Packaging, and Orderable Information**

The following pages include mechanical, packaging, and orderable information. This information is the most current data available for the designated devices. This data is subject to change without notice and revision of this document. For browser-based versions of this data sheet, refer to the left-hand navigation.

**PACKAGING INFORMATION**

Orderable Device	Status (1)	Package Type	Package Drawing	Pins	Package Qty	Eco Plan (2)	Lead finish/ Ball material (6)	MSL Peak Temp (3)	Op Temp (°C)	Device Marking (4/5)	Samples
BQ78Z100DRZR	ACTIVE	SON	DRZ	12	3000	RoHS & Green	NIPDAU	Level-2-260C-1 YEAR	-40 to 85	BQ78 Z100	<a href="#">Samples</a>
BQ78Z100DRZT	ACTIVE	SON	DRZ	12	250	RoHS & Green	NIPDAU	Level-2-260C-1 YEAR	-40 to 85	BQ78 Z100	<a href="#">Samples</a>

(1) The marketing status values are defined as follows:

**ACTIVE:** Product device recommended for new designs.

**LIFEBUY:** TI has announced that the device will be discontinued, and a lifetime-buy period is in effect.

**NRND:** Not recommended for new designs. Device is in production to support existing customers, but TI does not recommend using this part in a new design.

**PREVIEW:** Device has been announced but is not in production. Samples may or may not be available.

**OBSOLETE:** TI has discontinued the production of the device.

(2) **RoHS:** TI defines "RoHS" to mean semiconductor products that are compliant with the current EU RoHS requirements for all 10 RoHS substances, including the requirement that RoHS substance do not exceed 0.1% by weight in homogeneous materials. Where designed to be soldered at high temperatures, "RoHS" products are suitable for use in specified lead-free processes. TI may reference these types of products as "Pb-Free".

**RoHS Exempt:** TI defines "RoHS Exempt" to mean products that contain lead but are compliant with EU RoHS pursuant to a specific EU RoHS exemption.

**Green:** TI defines "Green" to mean the content of Chlorine (Cl) and Bromine (Br) based flame retardants meet JS709B low halogen requirements of <=1000ppm threshold. Antimony trioxide based flame retardants must also meet the <=1000ppm threshold requirement.

(3) MSL, Peak Temp. - The Moisture Sensitivity Level rating according to the JEDEC industry standard classifications, and peak solder temperature.

(4) There may be additional marking, which relates to the logo, the lot trace code information, or the environmental category on the device.

(5) Multiple Device Markings will be inside parentheses. Only one Device Marking contained in parentheses and separated by a "~" will appear on a device. If a line is indented then it is a continuation of the previous line and the two combined represent the entire Device Marking for that device.

(6) Lead finish/Ball material - Orderable Devices may have multiple material finish options. Finish options are separated by a vertical ruled line. Lead finish/Ball material values may wrap to two lines if the finish value exceeds the maximum column width.

**Important Information and Disclaimer:**The information provided on this page represents TI's knowledge and belief as of the date that it is provided. TI bases its knowledge and belief on information provided by third parties, and makes no representation or warranty as to the accuracy of such information. Efforts are underway to better integrate information from third parties. TI has taken and continues to take reasonable steps to provide representative and accurate information but may not have conducted destructive testing or chemical analysis on incoming materials and chemicals. TI and TI suppliers consider certain information to be proprietary, and thus CAS numbers and other limited information may not be available for release.

In no event shall TI's liability arising out of such information exceed the total purchase price of the TI part(s) at issue in this document sold by TI to Customer on an annual basis.





**TAPE AND REEL INFORMATION**

**QUADRANT ASSIGNMENTS FOR PIN 1 ORIENTATION IN TAPE**


\*All dimensions are nominal

Device	Package Type	Package Drawing	Pins	SPQ	Reel Diameter (mm)	Reel Width W1 (mm)	A0 (mm)	B0 (mm)	K0 (mm)	P1 (mm)	W (mm)	Pin1 Quadrant
BQ78Z100DRZR	SON	DRZ	12	3000	330.0	12.4	2.8	4.3	1.2	4.0	12.0	Q2
BQ78Z100DRZT	SON	DRZ	12	250	330.0	12.4	2.8	4.3	1.2	4.0	12.0	Q2

**TAPE AND REEL BOX DIMENSIONS**


\*All dimensions are nominal

Device	Package Type	Package Drawing	Pins	SPQ	Length (mm)	Width (mm)	Height (mm)
BQ78Z100DRZR	SON	DRZ	12	3000	338.1	338.1	20.6
BQ78Z100DRZT	SON	DRZ	12	250	338.1	338.1	20.6

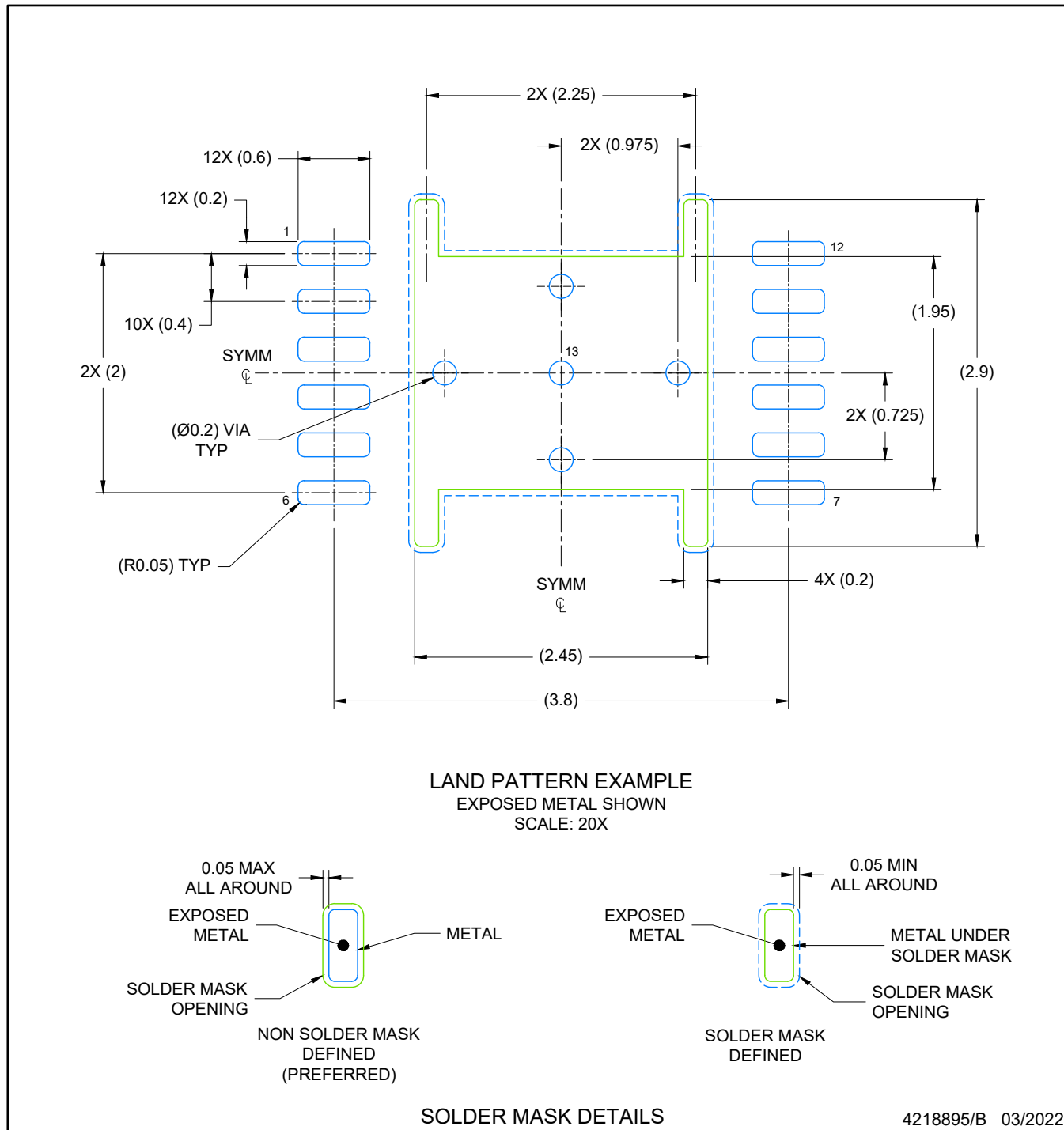


# EXAMPLE BOARD LAYOUT

DRZ0012A

VSON - 1 mm max height

PLASTIC QUAD FLATPACK- NO LEAD



NOTES: (continued)

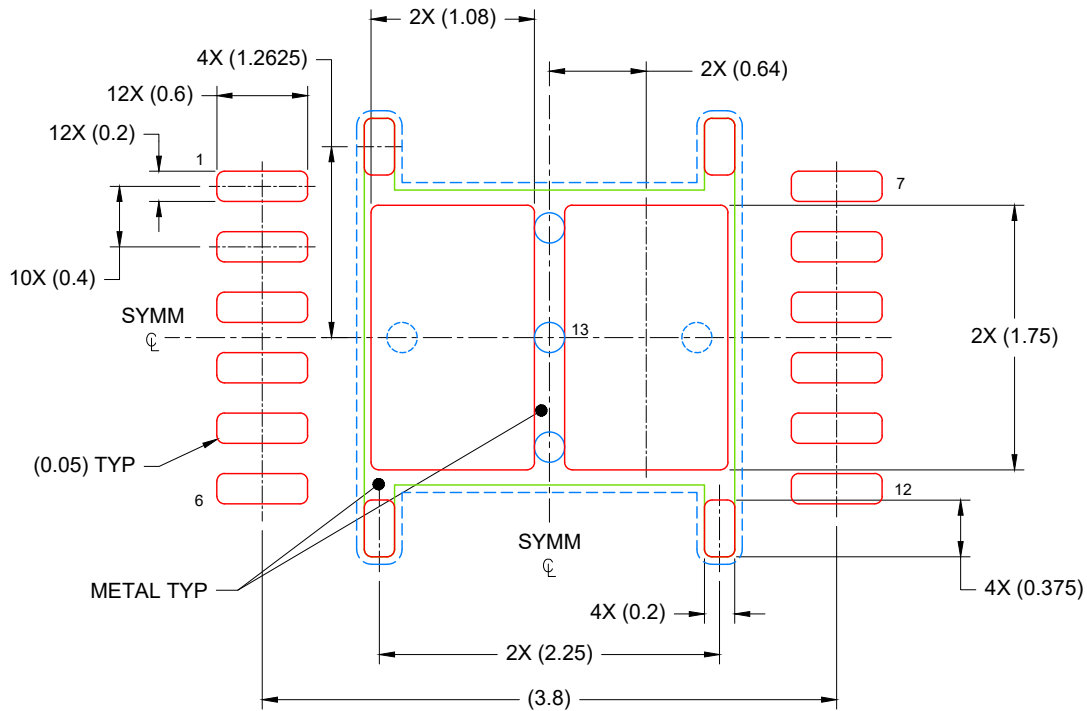
4. This package is designed to be soldered to a thermal pad on the board. For more information, see Texas Instruments literature number SLUA271 ([www.ti.com/lit/sluea271](http://www.ti.com/lit/sluea271)).
5. Vias are optional depending on application, refer to device data sheet. If any vias are implemented, refer to their locations shown on this view. It is recommended that vias under paste be filled, plugged or tented.

# EXAMPLE STENCIL DESIGN

DRZ0012A

VSON - 1 mm max height

PLASTIC QUAD FLATPACK- NO LEAD



4218895/B 03/2022

NOTES: (continued)

6. Laser cutting apertures with trapezoidal walls and rounded corners may offer better paste release. IPC-7525 may have alternate design recommendations.

## IMPORTANT NOTICE AND DISCLAIMER

TI PROVIDES TECHNICAL AND RELIABILITY DATA (INCLUDING DATA SHEETS), DESIGN RESOURCES (INCLUDING REFERENCE DESIGNS), APPLICATION OR OTHER DESIGN ADVICE, WEB TOOLS, SAFETY INFORMATION, AND OTHER RESOURCES "AS IS" AND WITH ALL FAULTS, AND DISCLAIMS ALL WARRANTIES, EXPRESS AND IMPLIED, INCLUDING WITHOUT LIMITATION ANY IMPLIED WARRANTIES OF MERCHANTABILITY, FITNESS FOR A PARTICULAR PURPOSE OR NON-INFRINGEMENT OF THIRD PARTY INTELLECTUAL PROPERTY RIGHTS.

These resources are intended for skilled developers designing with TI products. You are solely responsible for (1) selecting the appropriate TI products for your application, (2) designing, validating and testing your application, and (3) ensuring your application meets applicable standards, and any other safety, security, regulatory or other requirements.

These resources are subject to change without notice. TI grants you permission to use these resources only for development of an application that uses the TI products described in the resource. Other reproduction and display of these resources is prohibited. No license is granted to any other TI intellectual property right or to any third party intellectual property right. TI disclaims responsibility for, and you will fully indemnify TI and its representatives against, any claims, damages, costs, losses, and liabilities arising out of your use of these resources.

TI's products are provided subject to [TI's Terms of Sale](#) or other applicable terms available either on [ti.com](https://www.ti.com) or provided in conjunction with such TI products. TI's provision of these resources does not expand or otherwise alter TI's applicable warranties or warranty disclaimers for TI products.

TI objects to and rejects any additional or different terms you may have proposed.

Mailing Address: Texas Instruments, Post Office Box 655303, Dallas, Texas 75265  
Copyright © 2023, Texas Instruments Incorporated