

Features

- **Typical Propagation Delay:** 6ns at $V_{CC} = 5V$, $C_L = 15pF$, $T_A = 25^{\circ}C$, Fastest Part in QMOS Line
- **Wide Operating Temperature Range . . . $-55^{\circ}C$ to $125^{\circ}C$**
- **Balanced Propagation Delay and Transition Times**
- **Significant Power Reduction Compared to LSTTL Logic ICs**
- **HCU Types**
 - 2-V to 6-V Operation
 - **High Noise Immunity:** $N_{IL} = 20\%$, $N_{IH} = 30\%$ of V_{CC} at $V_{CC} = 5V$
- **CMOS Input Compatibility,** $I_I \leq 1\mu A$ at V_{OL} , V_{OH}

Description

The CD74HCU04 unbuffered hex inverter utilizes silicon-gate CMOS technology to achieve operation speeds similar to LSTTL gates, with the low power consumption of standard CMOS integrated circuits. These devices especially are useful in crystal oscillator and analog applications.

Ordering Information

| PART NUMBER | TEMP. RANGE ($^{\circ}C$) | PACKAGE |
|--------------|--------------------------------|-------------|
| CD74HCU04E | -55 to 125 | 14 Ld PDIP |
| CD74HCU04M | -55 to 125 | 14 Ld SOIC |
| CD74HCU04MT | -55 to 125 | 14 Ld SOIC |
| CD74HCU04M96 | -55 to 125 | 14 Ld SOIC |
| CD74HCU04PWR | -55 to 125 | 14 Ld TSSOP |

NOTE: When ordering, use the entire part number. The suffixes 96 and R denote tape and reel. The suffix T denotes a small-quantity reel of 250.

Pinout

CD74HCU04
(PDIP, SOIC, TSSOP)
TOP VIEW

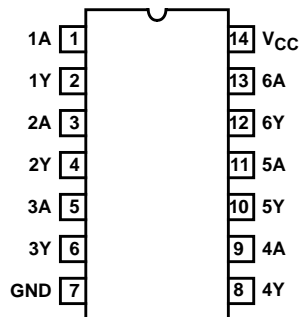

CD74HCU04

Functional Diagram

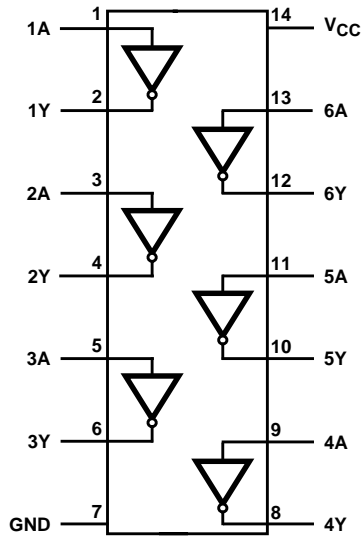

Logic Symbol

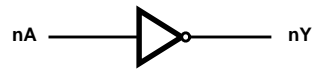

Schematic Diagram

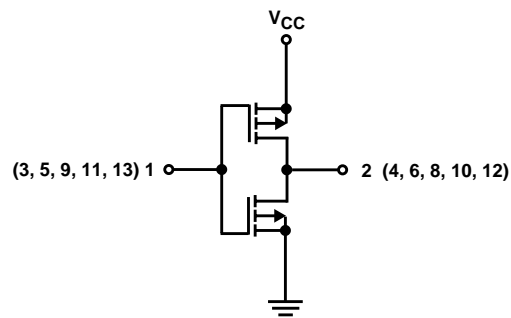

CD74HCU04

Absolute Maximum Ratings

| | |
|--|--------------|
| DC Supply Voltage, V_{CC} | |
| Voltages Referenced to Ground | -0.5V to +7V |
| DC Input Diode Current, I_{IK} | |
| For $V_I < -0.5V$ or $V_I > V_{CC} + 0.5V$ | $\pm 20mA$ |
| DC Output Diode Current, I_{OK} | |
| For $V_O < -0.5V$ or $V_O > V_{CC} + 0.5V$ | $\pm 20mA$ |
| DC Drain Current, per Output, I_O | |
| For $V_O > -0.5V$ or $V_O < V_{CC} + 0.5V$ | $\pm 25mA$ |
| DC V_{CC} or Ground Current, I_{CC} | $\pm 50mA$ |

Thermal Information

| | |
|--|------------------------------------|
| Thermal Resistance (Typical, Note 1) | θ_{JA} ($^{\circ}C/W$) |
| E (PDIP) Package | 80 |
| M (SOIC) Package | 86 |
| PW (TSSOP) Package | 113 |
| Maximum Junction Temperature (Hermetic Package or Die) | 175 $^{\circ}C$ |
| Maximum Junction Temperature (Plastic Package) | 150 $^{\circ}C$ |
| Maximum Storage Temperature Range | -65 $^{\circ}C$ to 150 $^{\circ}C$ |
| Maximum Lead Temperature (Soldering 10s) | 300 $^{\circ}C$ |
| (SOIC - Lead Tips Only) | |

Operating Conditions

| | |
|--|------------------------------------|
| Temperature Range T_A | -55 $^{\circ}C$ to 125 $^{\circ}C$ |
| Supply Voltage Range, V_{CC} | .2V to 6V |
| DC Input or Output Voltage, V_I, V_O | 0V to V_{CC} |

CAUTION: Stresses above those listed in "Absolute Maximum Ratings" may cause permanent damage to the device. This is a stress only rating, and operation of the device at these or any other conditions above those indicated in the operational sections of this specification is not implied.

NOTE:

- The package thermal impedance is calculated in accordance with JESD 51-7.

DC Electrical Specifications

| PARAMETER | SYMBOL | TEST CONDITIONS | | V_{CC} (V) | 25 $^{\circ}C$ | | -40 $^{\circ}C$ TO +85 $^{\circ}C$ | | -55 $^{\circ}C$ TO 125 $^{\circ}C$ | | UNITS |
|---|----------|-------------------------|------------|--------------|----------------|-----------|------------------------------------|---------|------------------------------------|---------|---------|
| | | V_I (V) | I_O (mA) | | MIN | MAX | MIN | MAX | MIN | MAX | |
| High Level Input Voltage | V_{IH} | - | - | 2 | 1.7 | - | 1.7 | - | 1.7 | - | V |
| | | | | 4.5 | 3.6 | - | 3.6 | - | 3.6 | - | V |
| | | | | 6 | 4.8 | - | 4.8 | - | 4.8 | - | V |
| Low Level Input Voltage | V_{IL} | - | - | 2 | - | 0.3 | - | 0.3 | - | 0.3 | V |
| | | | | 4.5 | - | 0.8 | - | 0.8 | - | 0.8 | V |
| | | | | 6 | - | 1.1 | - | 1.1 | - | 1.1 | V |
| High Level Output Voltage CMOS Loads | V_{OH} | V_{IH} or V_{IL} | -0.02 | 2 | 1.8 | - | 1.8 | - | 1.8 | - | V |
| | | | -0.02 | 4.5 | 4 | - | 4 | - | 4 | - | V |
| | | | -0.02 | 6 | 5.5 | - | 5.5 | - | 5.5 | - | V |
| High Level Output Voltage TTL Loads | V_{OH} | V_{CC} or GND | -4 | 4.5 | 3.98 | - | 3.84 | - | 3.7 | - | V |
| | | | -5.2 | 6 | 5.48 | - | 5.34 | - | 5.2 | - | V |
| Low Level Output Voltage CMOS Loads | V_{OL} | V_{IH} or V_{IL} | 0.02 | 2 | - | 0.2 | - | 0.2 | - | 0.2 | V |
| | | | 0.02 | 4.5 | - | 0.5 | - | 0.5 | - | 0.5 | V |
| | | | 0.02 | 6 | - | 0.5 | - | 0.5 | - | 0.5 | V |
| Low Level Output Voltage TTL Loads | V_{OL} | V_{CC} or GND | 4 | 4.5 | - | 0.26 | - | 0.33 | - | 0.4 | V |
| Input Leakage Current | I_I | V_{CC} or GND | - | 6 | - | ± 0.1 | - | ± 1 | - | ± 1 | μA |
| Quiescent Device Current | I_{CC} | V_{CC} or GND | 0 | 6 | - | 2 | - | 20 | - | 40 | μA |

CD74HCU04

Switching Specifications Input t_r , t_f = 6ns

| PARAMETER | SYMBOL | TEST CONDITIONS | V_{CC} (V) | 25°C | | | -40°C TO 85°C | | -55°C TO 125°C | | UNITS |
|---|-----------------------|---------------------|--------------|------|-----|-----|---------------|-----|----------------|-----|-------|
| | | | | MIN | TYP | MAX | MIN | MAX | MIN | MAX | |
| Propagation Delay, Input to Output Y (Figure 1) | t_{PLH} , t_{PHL} | $C_L = 50\text{pF}$ | 2 | - | - | 70 | - | 90 | - | 105 | ns |
| | | $C_L = 50\text{pF}$ | 4.5 | - | - | 14 | - | 18 | - | 21 | ns |
| | | $C_L = 15\text{pF}$ | 5 | - | 5 | - | - | - | - | - | ns |
| | | $C_L = 50\text{pF}$ | 6 | - | - | 12 | - | 15 | - | 18 | ns |
| Transition Times (Figure 1) | t_{TLH} , t_{THL} | $C_L = 50\text{pF}$ | 2 | - | - | 75 | - | 95 | 18 | 110 | ns |
| | | | 4.5 | - | - | 15 | - | 19 | - | 22 | ns |
| | | | 6 | - | - | 13 | - | 16 | - | 19 | ns |
| Input Capacitance | C_I | - | See Figure 3 | | | | | | | pF | |
| Power Dissipation Capacitance (Notes 2, 3) | C_{PD} | - | 5 | - | 14 | - | - | - | - | - | pF |

NOTES:

2. C_{PD} is used to determine the dynamic power consumption, per inverter.
3. $P_D = V_{CC}^2 f_i (C_{PD} + C_L)$ where f_i = input frequency, C_L = output load capacitance, V_{CC} = supply voltage.

Test Circuits and Waveforms

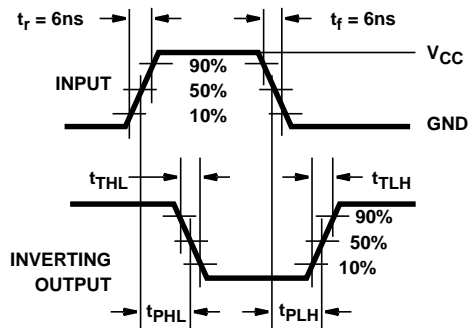

FIGURE 1. HC AND HCU TRANSITION TIMES AND PROPAGATION DELAY TIMES, COMBINATION LOGIC

Typical Performance Curves

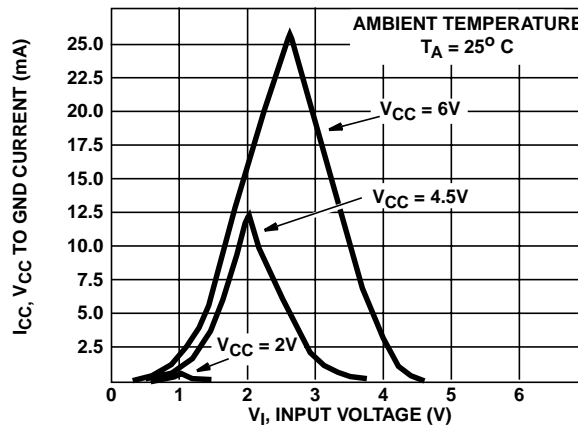

FIGURE 2. TYPICAL INVERTER SUPPLY CURRENT AS FUNCTION OF INPUT VOLTAGE

Typical Performance Curves (Continued)

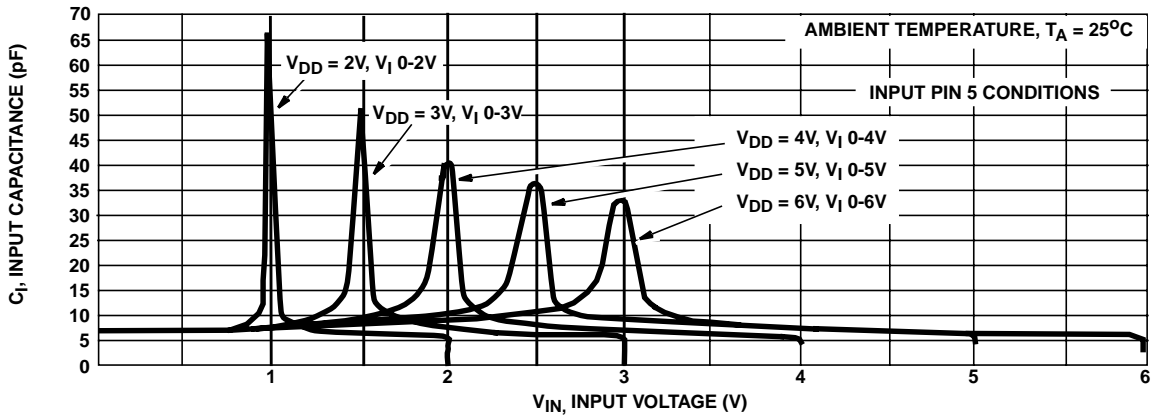

FIGURE 3. INPUT CAPACITANCE AS A FUNCTION OF INPUT VOLTAGE

PACKAGING INFORMATION

| Orderable Device | Status (1) | Package Type | Package Drawing | Pins | Package Qty | Eco Plan (2) | Lead finish/ Ball material (6) | MSL Peak Temp (3) | Op Temp (°C) | Device Marking (4/5) | Samples |
|------------------|---------------|--------------|-----------------|------|-------------|-----------------|--------------------------------------|----------------------|--------------|-------------------------|-------------------------|
| CD74HCU04E | ACTIVE | PDIP | N | 14 | 25 | RoHS & Green | NIPDAU | N / A for Pkg Type | -55 to 125 | CD74HCU04E | Samples |
| CD74HCU04M | OBSOLETE | SOIC | D | 14 | | TBD | Call TI | Call TI | -55 to 125 | HCU04M | |
| CD74HCU04M96 | ACTIVE | SOIC | D | 14 | 2500 | RoHS & Green | NIPDAU | Level-1-260C-UNLIM | -55 to 125 | HCU04M | Samples |
| CD74HCU04M96E4 | ACTIVE | SOIC | D | 14 | 2500 | RoHS & Green | NIPDAU | Level-1-260C-UNLIM | -55 to 125 | HCU04M | Samples |
| CD74HCU04M96G4 | ACTIVE | SOIC | D | 14 | 2500 | RoHS & Green | NIPDAU | Level-1-260C-UNLIM | -55 to 125 | HCU04M | Samples |
| CD74HCU04PWR | ACTIVE | TSSOP | PW | 14 | 2000 | RoHS & Green | NIPDAU | Level-1-260C-UNLIM | -55 to 125 | HJU04 | Samples |

(1) The marketing status values are defined as follows:

ACTIVE: Product device recommended for new designs.

LIFEBUY: TI has announced that the device will be discontinued, and a lifetime-buy period is in effect.

NRND: Not recommended for new designs. Device is in production to support existing customers, but TI does not recommend using this part in a new design.

PREVIEW: Device has been announced but is not in production. Samples may or may not be available.

OBSOLETE: TI has discontinued the production of the device.

(2) **RoHS:** TI defines "RoHS" to mean semiconductor products that are compliant with the current EU RoHS requirements for all 10 RoHS substances, including the requirement that RoHS substance do not exceed 0.1% by weight in homogeneous materials. Where designed to be soldered at high temperatures, "RoHS" products are suitable for use in specified lead-free processes. TI may reference these types of products as "Pb-Free".

RoHS Exempt: TI defines "RoHS Exempt" to mean products that contain lead but are compliant with EU RoHS pursuant to a specific EU RoHS exemption.

Green: TI defines "Green" to mean the content of Chlorine (Cl) and Bromine (Br) based flame retardants meet JS709B low halogen requirements of <=1000ppm threshold. Antimony trioxide based flame retardants must also meet the <=1000ppm threshold requirement.

(3) MSL, Peak Temp. - The Moisture Sensitivity Level rating according to the JEDEC industry standard classifications, and peak solder temperature.

(4) There may be additional marking, which relates to the logo, the lot trace code information, or the environmental category on the device.

(5) Multiple Device Markings will be inside parentheses. Only one Device Marking contained in parentheses and separated by a "~" will appear on a device. If a line is indented then it is a continuation of the previous line and the two combined represent the entire Device Marking for that device.

(6) Lead finish/Ball material - Orderable Devices may have multiple material finish options. Finish options are separated by a vertical ruled line. Lead finish/Ball material values may wrap to two lines if the finish value exceeds the maximum column width.

Important Information and Disclaimer: The information provided on this page represents TI's knowledge and belief as of the date that it is provided. TI bases its knowledge and belief on information provided by third parties, and makes no representation or warranty as to the accuracy of such information. Efforts are underway to better integrate information from third parties. TI has taken and continues to take reasonable steps to provide representative and accurate information but may not have conducted destructive testing or chemical analysis on incoming materials and chemicals. TI and TI suppliers consider certain information to be proprietary, and thus CAS numbers and other limited information may not be available for release.

In no event shall TI's liability arising out of such information exceed the total purchase price of the TI part(s) at issue in this document sold by TI to Customer on an annual basis.

OTHER QUALIFIED VERSIONS OF CD74HCU04 :

- Automotive : [CD74HCU04-Q1](#)

NOTE: Qualified Version Definitions:

- Automotive - Q100 devices qualified for high-reliability automotive applications targeting zero defects

TAPE AND REEL INFORMATION

QUADRANT ASSIGNMENTS FOR PIN 1 ORIENTATION IN TAPE



*All dimensions are nominal

| Device | Package Type | Package Drawing | Pins | SPQ | Reel Diameter (mm) | Reel Width W1 (mm) | A0 (mm) | B0 (mm) | K0 (mm) | P1 (mm) | W (mm) | Pin1 Quadrant |
|--------------|--------------|-----------------|------|------|--------------------|--------------------|---------|---------|---------|---------|--------|---------------|
| CD74HCU04M96 | SOIC | D | 14 | 2500 | 330.0 | 16.4 | 6.5 | 9.0 | 2.1 | 8.0 | 16.0 | Q1 |
| CD74HCU04PWR | TSSOP | PW | 14 | 2000 | 330.0 | 12.4 | 6.9 | 5.6 | 1.6 | 8.0 | 12.0 | Q1 |

TAPE AND REEL BOX DIMENSIONS

*All dimensions are nominal

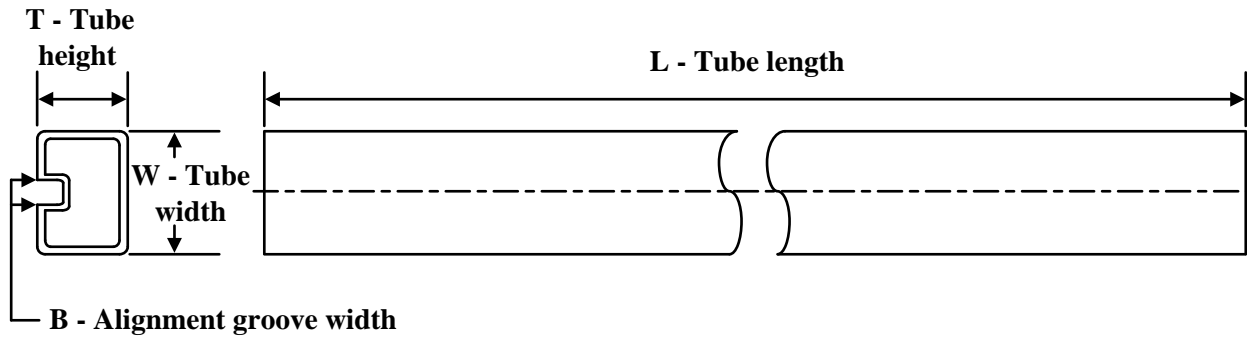
| Device | Package Type | Package Drawing | Pins | SPQ | Length (mm) | Width (mm) | Height (mm) |
|--------------|--------------|-----------------|------|------|-------------|------------|-------------|
| CD74HCU04M96 | SOIC | D | 14 | 2500 | 356.0 | 356.0 | 35.0 |
| CD74HCU04PWR | TSSOP | PW | 14 | 2000 | 356.0 | 356.0 | 35.0 |

TUBE

*All dimensions are nominal

| Device | Package Name | Package Type | Pins | SPQ | L (mm) | W (mm) | T (μm) | B (mm) |
|------------|--------------|--------------|------|-----|--------|--------|--------|--------|
| CD74HCU04E | N | PDIP | 14 | 25 | 506 | 13.97 | 11230 | 4.32 |
| CD74HCU04E | N | PDIP | 14 | 25 | 506 | 13.97 | 11230 | 4.32 |

D (R-PDSO-G14)

PLASTIC SMALL OUTLINE



- NOTES:
- A. All linear dimensions are in inches (millimeters).
 - B. This drawing is subject to change without notice.
 -  Body length does not include mold flash, protrusions, or gate burrs. Mold flash, protrusions, or gate burrs shall not exceed 0.006 (0,15) each side.
 -  Body width does not include interlead flash. Interlead flash shall not exceed 0.017 (0,43) each side.
 - E. Reference JEDEC MS-012 variation AB.

D (R-PDSO-G14)

PLASTIC SMALL OUTLINE



4211283-3/E 08/12

- NOTES:
- A. All linear dimensions are in millimeters.
 - B. This drawing is subject to change without notice.
 - C. Publication IPC-7351 is recommended for alternate designs.
 - D. Laser cutting apertures with trapezoidal walls and also rounding corners will offer better paste release. Customers should contact their board assembly site for stencil design recommendations. Refer to IPC-7525 for other stencil recommendations.
 - E. Customers should contact their board fabrication site for solder mask tolerances between and around signal pads.

PW (R-PDSO-G14)

PLASTIC SMALL OUTLINE

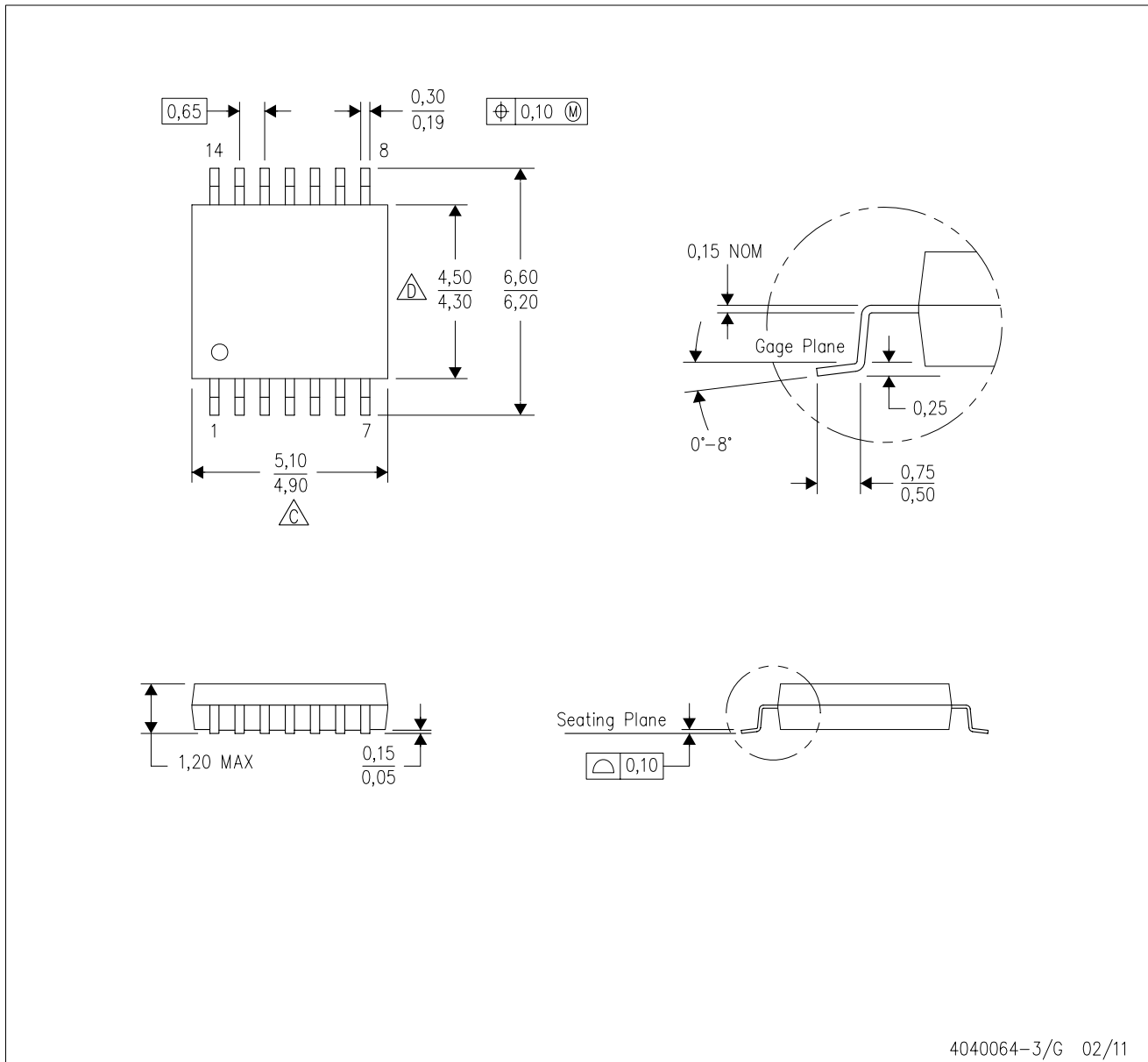

4040064-3/G 02/11

- NOTES:
- A. All linear dimensions are in millimeters. Dimensioning and tolerancing per ASME Y14.5M-1994.
 - B. This drawing is subject to change without notice.
 - C. Body length does not include mold flash, protrusions, or gate burrs. Mold flash, protrusions, or gate burrs shall not exceed 0,15 each side.
 - D. Body width does not include interlead flash. Interlead flash shall not exceed 0,25 each side.
 - E. Falls within JEDEC MO-153

PW (R-PDSO-G14)

PLASTIC SMALL OUTLINE



- NOTES:
- All linear dimensions are in millimeters.
 - This drawing is subject to change without notice.
 - Publication IPC-7351 is recommended for alternate designs.
 - Laser cutting apertures with trapezoidal walls and also rounding corners will offer better paste release. Customers should contact their board assembly site for stencil design recommendations. Refer to IPC-7525 for other stencil recommendations.
 - Customers should contact their board fabrication site for solder mask tolerances between and around signal pads.

N (R-PDIP-T**)

PLASTIC DUAL-IN-LINE PACKAGE

16 PINS SHOWN



- NOTES:
- A. All linear dimensions are in inches (millimeters).
 - B. This drawing is subject to change without notice.
 - C Falls within JEDEC MS-001, except 18 and 20 pin minimum body length (Dim A).
 - D The 20 pin end lead shoulder width is a vendor option, either half or full width.

4040049/E 12/2002

IMPORTANT NOTICE AND DISCLAIMER

TI PROVIDES TECHNICAL AND RELIABILITY DATA (INCLUDING DATA SHEETS), DESIGN RESOURCES (INCLUDING REFERENCE DESIGNS), APPLICATION OR OTHER DESIGN ADVICE, WEB TOOLS, SAFETY INFORMATION, AND OTHER RESOURCES "AS IS" AND WITH ALL FAULTS, AND DISCLAIMS ALL WARRANTIES, EXPRESS AND IMPLIED, INCLUDING WITHOUT LIMITATION ANY IMPLIED WARRANTIES OF MERCHANTABILITY, FITNESS FOR A PARTICULAR PURPOSE OR NON-INFRINGEMENT OF THIRD PARTY INTELLECTUAL PROPERTY RIGHTS.

These resources are intended for skilled developers designing with TI products. You are solely responsible for (1) selecting the appropriate TI products for your application, (2) designing, validating and testing your application, and (3) ensuring your application meets applicable standards, and any other safety, security, regulatory or other requirements.

These resources are subject to change without notice. TI grants you permission to use these resources only for development of an application that uses the TI products described in the resource. Other reproduction and display of these resources is prohibited. No license is granted to any other TI intellectual property right or to any third party intellectual property right. TI disclaims responsibility for, and you will fully indemnify TI and its representatives against, any claims, damages, costs, losses, and liabilities arising out of your use of these resources.

TI's products are provided subject to [TI's Terms of Sale](#) or other applicable terms available either on [ti.com](https://www.ti.com) or provided in conjunction with such TI products. TI's provision of these resources does not expand or otherwise alter TI's applicable warranties or warranty disclaimers for TI products.

TI objects to and rejects any additional or different terms you may have proposed.

Mailing Address: Texas Instruments, Post Office Box 655303, Dallas, Texas 75265
Copyright © 2024, Texas Instruments Incorporated