

# DAC121C081 and DAC121C085 12-Bit Micro Power Digital-to-Analog Converter With an I<sup>2</sup>C-Compatible Interface

## 1 Features

- Ensured Monotonicity to 12-Bits
- Low Power Operation: 156- $\mu$ A Maximum at 3.3 V
- Extended Power Supply Range (2.7 V to 5.5 V)
- I<sup>2</sup>C-Compatible 2-Wire Interface Which Supports Standard (100-kHz), Fast (400-kHz), and High-Speed (3.4-MHz) Modes
- Rail-to-Rail Voltage Output
- Very Small Package
- Resolution: 12 bits
- INL:  $\pm 8$  LSB (Maximum)
- DNL: 0.6 /  $-0.5$  LSB (Maximum)
- Settling Time: 8.5  $\mu$ s (Maximum)
- Zero Code Error: 10 mV (Maximum)
- Full-Scale Error:  $-0.7\%$ FS (Maximum)
- Supply Power
  - Normal: 380  $\mu$ W (3 V) / 730  $\mu$ W (5 V) (Typical)
  - Power Down: 0.5  $\mu$ W (3 V) / 0.9  $\mu$ W (5 V) (Typical)

## 2 Applications

- Industrial Process Control
- Portable Instruments
- Digital Gain and Offset Adjustment
- Programmable Voltage and Current Sources
- Test Equipment

## 3 Description

The DAC121C081 is a 12-bit, single-channel, voltage-output digital-to-analog converter (DAC) that operates from a 2.7-V to 5.5-V supply. The output amplifier allows rail-to-rail output swing and has an 8.5- $\mu$ s settling time. The DAC121C081 uses the supply voltage as the reference to provide the widest dynamic output range, and typically consumes 132  $\mu$ A while operating at 5 V. It is available in 6-pin SOT and WSON packages, and provides three address options (pin selectable).

As an alternative, the DAC121C085 provides nine I<sup>2</sup>C addressing options and uses an external reference. It has the same performance and settling time as the DAC121C081, and is available in an 8-lead VSSOP.

### Device Information<sup>(1)</sup>

PART NUMBER	PACKAGE	BODY SIZE (NOM)
DAC121C081	WSON (6)	2.20 mm x 2.50 mm
	SOT (6)	1.60 mm x 2.90 mm
DAC121C085	VSSOP (8)	3.00 mm x 3.00 mm

(1) For all available packages, see the orderable addendum at the end of the data sheet.

### Block Diagram

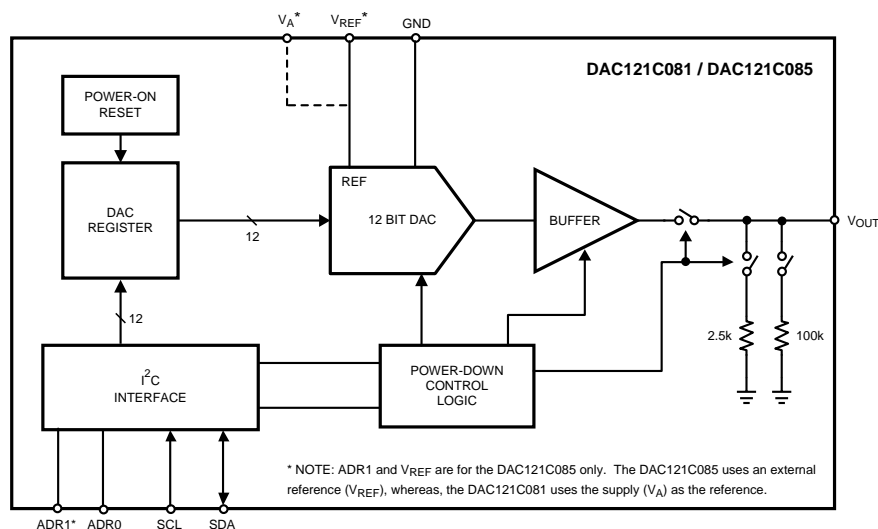

## Table of Contents

<b>1 Features</b> .....	<b>1</b>	8.5 Programming.....	<b>20</b>
<b>2 Applications</b> .....	<b>1</b>	8.6 Registers .....	<b>21</b>
<b>3 Description</b> .....	<b>1</b>	<b>9 Application and Implementation</b> .....	<b>22</b>
<b>4 Revision History</b> .....	<b>2</b>	9.1 Application Information.....	<b>22</b>
<b>5 Description (continued)</b> .....	<b>3</b>	9.2 Typical Application .....	<b>24</b>
<b>6 Pin Configuration and Functions</b> .....	<b>4</b>	<b>10 Power Supply Recommendations</b> .....	<b>26</b>
<b>7 Specifications</b> .....	<b>5</b>	10.1 Using References as Power Supplies.....	<b>26</b>
7.1 Absolute Maximum Ratings .....	<b>5</b>	<b>11 Layout</b> .....	<b>29</b>
7.2 ESD Ratings.....	<b>5</b>	11.1 Layout Guidelines .....	<b>29</b>
7.3 Recommended Operating Conditions.....	<b>6</b>	11.2 Layout Example .....	<b>29</b>
7.4 Thermal Information .....	<b>6</b>	<b>12 Device and Documentation Support</b> .....	<b>30</b>
7.5 Electrical Characteristics.....	<b>7</b>	12.1 Device Support.....	<b>30</b>
7.6 AC and Timing Characteristics .....	<b>9</b>	12.2 Documentation Support .....	<b>31</b>
7.7 Typical Characteristics .....	<b>12</b>	12.3 Related Links .....	<b>31</b>
<b>8 Detailed Description</b> .....	<b>15</b>	12.4 Trademarks .....	<b>31</b>
8.1 Overview .....	<b>15</b>	12.5 Electrostatic Discharge Caution.....	<b>31</b>
8.2 Functional Block Diagram .....	<b>15</b>	12.6 Glossary .....	<b>31</b>
8.3 Feature Description.....	<b>15</b>	<b>13 Mechanical, Packaging, and Orderable Information</b> .....	<b>31</b>
8.4 Device Functional Modes.....	<b>20</b>		

## 4 Revision History

NOTE: Page numbers for previous revisions may differ from page numbers in the current version.

<b>Changes from Revision E (January 2016) to Revision F</b>	<b>Page</b>
• Changed $V_{OUT}$ and $V_A$ descriptions. ....	<b>4</b>
• Added column to Table 1. ....	<b>19</b>

<b>Changes from Revision D (March 2013) to Revision E</b>	<b>Page</b>
• Added <i>ESD Ratings</i> table, <i>Feature Description</i> section, <i>Device Functional Modes</i> , <i>Application and Implementation</i> section, <i>Power Supply Recommendations</i> section, <i>Layout</i> section, <i>Device and Documentation Support</i> section, and <i>Mechanical, Packaging, and Orderable Information</i> section. ....	<b>1</b>
• Added addresses that the DAC responds to on the I2C bus. ....	<b>18</b>

<b>Changes from Revision C (March 2013) to Revision D</b>	<b>Page</b>
• Changed layout of National Semiconductor Data Sheet to TI format .....	<b>29</b>

## 5 Description (continued)

The DAC121C081 and DAC121C085 use a 2-wire, I<sup>2</sup>C-compatible serial interface that operates in all three speed modes, including high-speed mode (3.4 MHz). An external address selection pin allows up to three DAC121C081 or nine DAC121C085 devices per 2-wire bus. Pin compatible alternatives to the DAC121C081 are available that provide additional address options.

The DAC121C081 and DAC121C085 each have a 16-bit register that controls the mode of operation, the power-down condition, and the output voltage. A power-on reset circuit ensures that the DAC output powers up to 0 V. A power-down feature reduces power consumption to less than a microWatt. Their low power consumption and small packages make these DACs an excellent choice for use in battery-operated equipment. Each DAC operates over the extended industrial temperature range of –40°C to +125°C.

The DAC121C081 and DAC121C085 are each part of a family of pin compatible DACs that also provide 8 and 10 bit resolution. For 8-bit DACs see the DAC081C081 and DAC081C085. For 10-bit DACs see the DAC101C081 and DAC101C085.

## 6 Pin Configuration and Functions

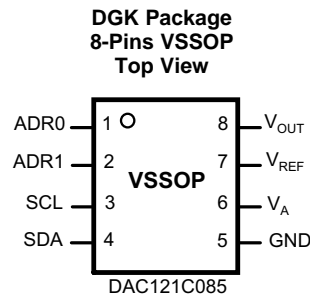
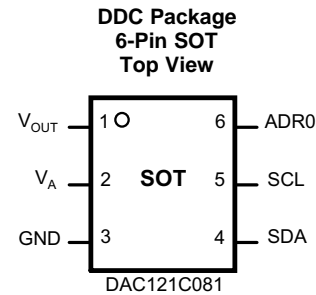
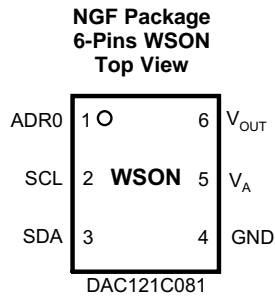

### Pin Functions

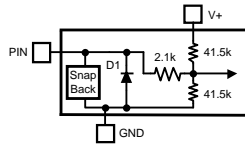
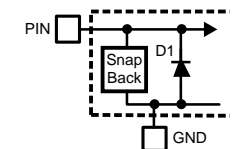
PIN				TYPE	DESCRIPTION	EQUIVALENT CIRCUIT
NAME	WSON	SOT	VSSOP			
ADR0	1	6	1	Digital Input, three levels	Tri-state Address Selection Input. Sets the two Least Significant Bits (A1 and A0) of the 7-bit slave address. (see <a href="#">Table 1</a> )	
ADR1	—	—	2	Digital Input, three levels	Tri-state Address Selection Input. Sets Bits A6 and A3 of the 7-bit slave address. (see <a href="#">Table 1</a> )	
GND	4	3	5	Ground	Ground for all on-chip circuitry	—
SCL	2	5	3	Digital Input	Serial Clock Input. SCL is used together with SDA to control the transfer of data in and out of the device.	
SDA	3	4	4	Digital Input/Output	Serial Data bi-directional connection. Data is clocked into or out of the internal 16-bit register relative to the clock edges of SCL. This is an open-drain data line that must be pulled to the supply ( $V_A$ ) by an external pullup resistor.	
$V_{OUT}$	6	1	8	Analog Output	Analog Output Voltage	—
$V_A$	5	2	6	Supply	Power supply input. For the SOT and WSON versions, this supply is used as the reference. Must be decoupled to GND.	—
VREF	—	—	7	Supply	Unbuffered reference voltage. For the VSSOP, this supply is used as the reference. $V_{REF}$ must be free of noise and decoupled to GND.	—
PAD	(LLP only)	—	—	Ground	Exposed die attach pad can be connected to ground or left floating. Soldering the pad to the PCB offers optimal thermal performance and enhances package self-alignment during reflow.	—

## 7 Specifications

### 7.1 Absolute Maximum Ratings

over operating free-air temperature range (unless otherwise noted)<sup>(1)(2)(3)</sup>

	MIN	MAX	UNIT
Supply voltage, $V_A$	-0.3	6.5	V
Voltage on any input pin	-0.3	6.5	V
Input current at any pin <sup>(4)</sup>		±10	mA
Package input current <sup>(4)</sup>		±20	mA
Power consumption at $T_A = 25^\circ\text{C}$		See <sup>(5)</sup>	
Junction temperature, $T_J$		150	°C
Storage temperature, $T_{\text{stg}}$	-65	150	°C

- Stresses beyond those listed under *Absolute Maximum Ratings* may cause permanent damage to the device. These are stress ratings only, which do not imply functional operation of the device at these or any other conditions beyond those indicated under *Recommended Operating Conditions*. Exposure to absolute-maximum-rated conditions for extended periods may affect device reliability.
- All voltages are measured with respect to GND = 0 V, unless otherwise specified.
- If Military/Aerospace specified devices are required, contact the Texas Instruments Sales Office/ Distributors for availability and specifications.
- When the input voltage at any pin exceeds 5.5 V or is less than GND, the current at that pin should be limited to 10 mA. The 20-mA maximum package input current ratings limits the number of pins that can safely exceed the power supplies with an input current of 10 mA to two.
- The absolute maximum junction temperature ( $T_{J\text{max}}$ ) for this device is 150°C. The maximum allowable power dissipation is dictated by  $T_{J\text{max}}$ , the junction-to-ambient thermal resistance ( $\theta_{JA}$ ), and the ambient temperature ( $T_A$ ), and can be calculated using the formula  $P_{\text{DMAX}} = (T_{J\text{max}} - T_A) / \theta_{JA}$ . The values for maximum power dissipation will be reached only when the device is operated in a severe fault condition (for example, when input or output pins are driven beyond the operating ratings, or the power supply polarity is reversed).

### 7.2 ESD Ratings

			VALUE	UNIT	
<b>DAC081C081 in NGF Package</b>					
$V_{\text{(ESD)}}$	Electrostatic discharge	Human-body model (HBM), per ANSI/ESDA/JEDEC JS-001	All pins except 2 and 3	±2500	V
			Pins 2 and 3	±5000	
		Charged-device model (CDM), per JEDEC specification JESD22-C101	All pins except 2 and 3	±1000	
			Pins 2 and 3	±1000	
		Machine model (MM)	All pins except 2 and 3	±250	
			Pins 2 and 3	±350	
<b>DAC081C081 in DDC Package</b>					
$V_{\text{(ESD)}}$	Electrostatic discharge	Human-body model (HBM), per ANSI/ESDA/JEDEC JS-001	All pins except 4 and 5	±2500	V
			Pins 4 and 5	±5000	
		Charged-device model (CDM), per JEDEC specification JESD22-C101	All pins except 4 and 5	±1000	
			Pins 4 and 5	±1000	
		Machine model (MM)	All pins except 4 and 5	±250	
			Pins 4 and 5	±350	
<b>DAC081C085 in DGK Package</b>					
$V_{\text{(ESD)}}$	Electrostatic discharge	Human-body model (HBM), per ANSI/ESDA/JEDEC JS-001	All pins except 3 and 4	±2500	V
			Pins 3 and 4	±5000	
		Charged-device model (CDM), per JEDEC specification JESD22-C101	All pins except 3 and 4	±1000	
			Pins 3 and 4	±1000	
		Machine model (MM)	All pins except 3 and 4	±250	
			Pins 3 and 4	±350	

**DAC121C081, DAC121C085**

SNAS395F – DECEMBER 2007 – REVISED OCTOBER 2016

[www.ti.com](http://www.ti.com)

### 7.3 Recommended Operating Conditions

 over operating free-air temperature range (unless otherwise noted)<sup>(1)</sup>

	MIN	MAX	UNIT
Operating temperature, $T_A$	-40	125	°C
Supply voltage, $V_A$	2.7	5.5	V
Reference voltage, $V_{REFIN}$	1	$V_A$	V
Digital input voltage <sup>(2)</sup>	0	5.5	V
Output load	0	1500	pF

(1) All voltages are measured with respect to GND = 0 V, unless otherwise specified.

 (2) The inputs are protected as shown in the following. Input voltage magnitudes up to 5.5 V, regardless of  $V_A$ , will not cause errors in the conversion result. For example, if  $V_A$  is 3 V, the digital input pins can be driven with a 5-V logic device.

### 7.4 Thermal Information

THERMAL METRIC <sup>(1)(2)(3)</sup>	DAC121C081		DAC121C085	UNIT
	NGF (WSON)	DDC (SOT)	DGK (VSSOP)	
	6 PINS	6 PINS	8 PINS	
$R_{\theta JA}$ Junction-to-ambient thermal resistance	190	250	240	°C/W

 (1) For more information about traditional and new thermal metrics, see the [Semiconductor and IC Package Thermal Metrics](#) application report.

 (2) Soldering process must comply with Texas Instruments' [Reflow Temperature Profile Specifications](#), SNOA549.

(3) Reflow temperature profiles are different for lead-free packages.

## 7.5 Electrical Characteristics

The following specifications apply for  $V_A = 2.7\text{ V}$  to  $5.5\text{ V}$ ,  $V_{REF} = V_A$ ,  $C_L = 200\text{ pF}$  to GND, input code range 48 to 4047. All Maximum and Minimum limits apply for  $T_{MIN} \leq T_A \leq T_{MAX}$  and all Typical limits are at  $T_A = 25^\circ\text{C}$ , unless otherwise specified.<sup>(1)</sup>

PARAMETER		TEST CONDITIONS	MIN	TYP <sup>(2)</sup>	MAX <sup>(2)</sup>	UNIT
<b>STATIC PERFORMANCE</b>						
INL	Resolution		12			Bits
	Monotonicity		12			Bits
	Integral Non-Linearity			2.2	8	LSB
			-8	-1.5		
DNL	Differential Non-Linearity			0.18	0.6	LSB
				-0.5	-0.12	LSB
ZE	Zero Code Error	$I_{OUT} = 0$		1.1	10	mV
FSE	Full-Scale Error	$I_{OUT} = 0$		-0.1	-0.7	%FSR
GE	Gain Error	All ones Loaded to DAC register		-0.2	-0.7	%FSR
ZCED	Zero Code Error Drift			-20		$\mu\text{V}/^\circ\text{C}$
TC GE	Gain Error Tempco	$V_A = 3\text{ V}$		-0.7		ppm FSR/ $^\circ\text{C}$
		$V_A = 5\text{ V}$		-1		
<b>ANALOG OUTPUT CHARACTERISTICS (<math>V_{OUT}</math>)</b>						
	Output voltage range <sup>(3)</sup>	DAC121C085	0		$V_{REF}$	V
		DAC121C081	0		$V_A$	
ZCO	Zero code output	$V_A = 3\text{ V}$ , $I_{OUT} = 200\ \mu\text{A}$		1.3		mV
		$V_A = 5\text{ V}$ , $I_{OUT} = 200\ \mu\text{A}$		7		
FSO	Full scale output	$V_A = 3\text{ V}$ , $I_{OUT} = 200\ \mu\text{A}$		2.984		V
		$V_A = 5\text{ V}$ , $I_{OUT} = 200\ \mu\text{A}$		4.989		
$I_{OS}$	Output short-circuit current ( $I_{SOURCE}$ )	$V_A = 3\text{ V}$ , $V_{OUT} = 0\text{ V}$ , Input Code = FFFh.		56		mA
		$V_A = 5\text{ V}$ , $V_{OUT} = 0\text{ V}$ , Input Code = FFFh.		69		
$I_{OS}$	Output short-circuit current ( $I_{SINK}$ )	$V_A = 3\text{ V}$ , $V_{OUT} = 3\text{ V}$ , Input Code = 000h.		-52		mA
		$V_A = 5\text{ V}$ , $V_{OUT} = 5\text{ V}$ , Input Code = 000h.		-75		
$I_O$	Continuous output current <sup>(3)</sup>	Available on the DAC output			11	mA
$C_L$	Maximum load capacitance	$R_L = \infty$		1500		pF
		$R_L = 2\text{ k}\Omega$		1500		
$Z_{OUT}$	DC output impedance			7.5		$\Omega$
<b>REFERENCE INPUT CHARACTERISTICS (DAC121C085 only)</b>						
$V_{REF}$	Input range minimum		1	0.2		V
	Input range maximum				$V_A$	V
	Input impedance			120		k $\Omega$
<b>LOGIC INPUT CHARACTERISTICS (SCL, SDA)</b>						
$V_{IH}$	Input high voltage		$0.7 \times V_A$			V
$V_{IL}$	Input low voltage			$0.3 \times V_A$		V
$I_{IN}$	Input current			$\pm 1$		$\mu\text{A}$
$C_{IN}$	Input pin capacitance <sup>(3)</sup>				3	pF
$V_{HYST}$	Input hysteresis		$0.1 \times V_A$			V
<b>LOGIC INPUT CHARACTERISTICS (ADR0, ADR1)</b>						
$V_{IH}$	Input high voltage		$V_A - 0.5$			V

(1) Values shown in this table are design targets and are subject to change before product release.

(2) Typical figures are at  $T_J = 25^\circ\text{C}$ , and represent most likely parametric norms. Test limits are specified to AOQL (Average Outgoing Quality Level).

(3) This parameter is specified by design and/or characterization and is not tested in production.

**Electrical Characteristics (continued)**

The following specifications apply for  $V_A = 2.7\text{ V}$  to  $5.5\text{ V}$ ,  $V_{REF} = V_A$ ,  $C_L = 200\text{ pF}$  to GND, input code range 48 to 4047. All Maximum and Minimum limits apply for  $T_{MIN} \leq T_A \leq T_{MAX}$  and all Typical limits are at  $T_A = 25^\circ\text{C}$ , unless otherwise specified.<sup>(1)</sup>

PARAMETER		TEST CONDITIONS	MIN	TYP <sup>(2)</sup>	MAX <sup>(2)</sup>	UNIT
$V_{IL}$	Input low voltage				0.5	V
$I_{IN}$	Input current				$\pm 1$	$\mu\text{A}$
<b>LOGIC OUTPUT CHARACTERISTICS (SDA)</b>						
$V_{OL}$	Output low voltage	$I_{SINK} = 3\text{ mA}$			0.4	V
		$I_{SINK} = 6\text{ mA}$			0.6	
$I_{OZ}$	High-impedance output leakage current				$\pm 1$	$\mu\text{A}$
<b>POWER REQUIREMENTS</b>						
$V_A$	Supply voltage minimum		2.7			V
	Supply voltage maximum				5.5	
<b>Normal -- <math>V_{OUT}</math> set to midscale. 2-wire interface quiet (SCL = SDA = <math>V_A</math>). (output unloaded)</b>						
$I_{ST\_VA-1}$	$V_A$ DAC121C081 supply current	$V_A = 2.7\text{ V}$ to $3.6\text{ V}$		105	156	$\mu\text{A}$
		$V_A = 4.5\text{ V}$ to $5.5\text{ V}$		132	214	
$I_{ST\_VA-5}$	$V_A$ DAC121C085 supply current	$V_A = 2.7\text{ V}$ to $3.6\text{ V}$		86	118	$\mu\text{A}$
		$V_A = 4.5\text{ V}$ to $5.5\text{ V}$		98	152	
$I_{ST\_VREF}$	$V_{REF}$ supply current (DAC121C085 only)	$V_A = 2.7\text{ V}$ to $3.6\text{ V}$		37	43	$\mu\text{A}$
		$V_A = 4.5\text{ V}$ to $5.5\text{ V}$		53	61	
$P_{ST}$	Power consumption ( $V_A$ and $V_{REF}$ for DAC121C085) <sup>(4)</sup>	$V_A = 3\text{ V}$		380		$\mu\text{W}$
		$V_A = 5\text{ V}$		730		
<b>Continuous Operation -- 2-wire interface actively addressing the DAC and writing to the DAC register. (output unloaded)</b>						
$I_{CO\_VA-1}$	$V_A$ DAC121C081 supply current	$f_{SCL} = 400\text{ kHz}$	$V_A = 2.7\text{ V}$ to $3.6\text{ V}$	134	220	$\mu\text{A}$
			$V_A = 4.5\text{ V}$ to $5.5\text{ V}$	192	300	
		$f_{SCL} = 3.4\text{ MHz}$	$V_A = 2.7\text{ V}$ to $3.6\text{ V}$	225	320	$\mu\text{A}$
			$V_A = 4.5\text{ V}$ to $5.5\text{ V}$	374	500	
$I_{CO\_VA-5}$	$V_A$ DAC121C085 supply current	$f_{SCL} = 400\text{ kHz}$	$V_A = 2.7\text{ V}$ to $3.6\text{ V}$	101	155	$\mu\text{A}$
			$V_A = 4.5\text{ V}$ to $5.5\text{ V}$	142	220	
		$f_{SCL} = 3.4\text{ MHz}$	$V_A = 2.7\text{ V}$ to $3.6\text{ V}$	193	235	$\mu\text{A}$
			$V_A = 4.5\text{ V}$ to $5.5\text{ V}$	325	410	
$I_{CO\_VREF}$	$V_{REF}$ supply current (DAC121C085 only)	$V_A = 2.7\text{ V}$ to $3.6\text{ V}$		33.5	55	$\mu\text{A}$
		$V_A = 4.5\text{ V}$ to $5.5\text{ V}$		49.5	71.4	
$P_{CO}$	Power consumption ( $V_A$ and $V_{REF}$ for DAC121C085)	$f_{SCL} = 400\text{ kHz}$	$V_A = 3\text{ V}$	480		$\mu\text{W}$
			$V_A = 5\text{ V}$	1.06		mW
		$f_{SCL} = 3.4\text{ MHz}$	$V_A = 3\text{ V}$	810		$\mu\text{W}$
			$V_A = 5\text{ V}$	2.06		mW
<b>Power Down -- 2-wire interface quiet (SCL = SDA = <math>V_A</math>) after PD mode written to DAC register. (output unloaded)</b>						
$I_{PD}$	Supply current ( $V_A$ and $V_{REF}$ for DAC121C085)	All power-down modes	$V_A = 2.7\text{ V}$ to $3.6\text{ V}$	0.13	1.52	$\mu\text{A}$
			$V_A = 4.5\text{ V}$ to $5.5\text{ V}$	0.15	3.25	
$P_{PD}$	Power consumption ( $V_A$ and $V_{REF}$ for DAC121C085)	All power-down modes	$V_A = 3\text{ V}$	0.5		$\mu\text{W}$
			$V_A = 5\text{ V}$	0.9		

(4) To ensure accuracy, it is required that  $V_A$  and  $V_{REF}$  be well bypassed.



## 7.6 AC and Timing Characteristics

The following specifications apply for  $V_A = 2.7\text{ V}$  to  $5.5\text{ V}$ ,  $V_{REF} = V_A$ ,  $R_L = \text{Infinity}$ ,  $C_L = 200\text{ pF}$  to GND. All Maximum and Minimum limits apply for  $T_{MIN} \leq T_A \leq T_{MAX}$  and all Typical limits are at  $T_A = 25^\circ\text{C}$ , unless otherwise specified.<sup>(1)</sup>

PARAMETER		TEST CONDITIONS <sup>(2)</sup>	MIN	TYP <sup>(3)</sup>	MAX <sup>(2)(3)</sup>	UNIT
$t_s$	Output Voltage Settling Time <sup>(4)</sup>	400h to C00h code change $R_L = 2\text{ k}\Omega$ , $C_L = 200\text{ pF}$		6	8.5	$\mu\text{s}$
SR	Output Slew Rate			1		$\text{V}/\mu\text{s}$
	Glitch Impulse	Code change from 800h to 7FFh		12		nV-sec
	Digital Feedthrough			0.5		nV-sec
	Multiplying Bandwidth <sup>(5)</sup>	$V_{REF} = 2.5\text{ V} \pm 0.1\text{ Vpp}$		160		kHz
	Total Harmonic Distortion <sup>(5)</sup>	$V_{REF} = 2.5\text{ V} \pm 0.1\text{ Vpp}$ input frequency = 10 kHz		70		dB
$t_{WU}$	Wake-Up Time	$V_A = 3\text{ V}$		0.8		$\mu\text{s}$
		$V_A = 5\text{ V}$		0.5		$\mu\text{s}$
<b>DIGITAL TIMING SPECS (SCL, SDA)</b>						
$f_{SCL}$	Serial Clock Frequency	Standard Mode			100	kHz
		Fast Mode			400	
		High Speed Mode, $C_b = 100\text{ pF}$			3.4	MHz
		High Speed Mode, $C_b = 400\text{ pF}$			1.7	
$t_{LOW}$	SCL Low Time	Standard Mode	4.7			$\mu\text{s}$
		Fast Mode	1.3			
		High Speed Mode, $C_b = 100\text{ pF}$	160			ns
		High Speed Mode, $C_b = 400\text{ pF}$	320			
$t_{HIGH}$	SCL High Time	Standard Mode	4			$\mu\text{s}$
		Fast Mode	0.6			
		High Speed Mode, $C_b = 100\text{ pF}$	60			ns
		High Speed Mode, $C_b = 400\text{ pF}$	120			
$t_{SU,DAT}$	Data Setup Time	Standard Mode	250			ns
		Fast Mode	100			
		High Speed Mode	10			
$t_{HD,DAT}$	Data Hold Time	Standard Mode	0		3.45	$\mu\text{s}$
		Fast Mode	0		0.9	
		High Speed Mode, $C_b = 100\text{ pF}$	0		70	ns
		High Speed Mode, $C_b = 400\text{ pF}$	0		150	
$t_{SU,STA}$	Setup time for a start or a repeated start condition	Standard Mode	4.7			$\mu\text{s}$
		Fast Mode	0.6			
		High Speed Mode	160			ns
$t_{HD,STA}$	Hold time for a start or a repeated start condition	Standard Mode	4			$\mu\text{s}$
		Fast Mode	0.6			
		High Speed Mode	160			ns
$t_{BUF}$	Bus free time between a stop and start condition	Standard Mode	4.7			$\mu\text{s}$
		Fast Mode	1.3			
$t_{SU,STO}$	Setup time for a stop condition	Standard Mode	4			$\mu\text{s}$
		Fast Mode	0.6			
		High Speed Mode	160			ns

(1) Values shown in this table are design targets and are subject to change before product release.

(2)  $C_b$  refers to the capacitance of one bus line.  $C_b$  is expressed in pF units.

(3) Typical figures are at  $T_J = 25^\circ\text{C}$ , and represent most likely parametric norms. Test limits are specified to AOQL (Average Outgoing Quality Level).

(4) This parameter is specified by design and/or characterization and is not tested in production.

(5) Applies to the Multiplying DAC configuration. In this configuration, the reference is used as the analog input. The value loaded in the DAC Register will digitally attenuate the signal at  $V_{out}$ .

## AC and Timing Characteristics (continued)

The following specifications apply for  $V_A = 2.7\text{ V to }5.5\text{ V}$ ,  $V_{REF} = V_A$ ,  $R_L = \text{Infinity}$ ,  $C_L = 200\text{ pF to GND}$ . All Maximum and Minimum limits apply for  $T_{MIN} \leq T_A \leq T_{MAX}$  and all Typical limits are at  $T_A = 25^\circ\text{C}$ , unless otherwise specified.<sup>(1)</sup>

PARAMETER		TEST CONDITIONS <sup>(2)</sup>	MIN	TYP <sup>(3)</sup>	MAX <sup>(2)(3)</sup>	UNIT
$t_{rDA}$	Rise time of SDA signal	Standard Mode			1000	ns
		Fast Mode	$20+0.1C_b$		300	
		High Speed Mode, $C_b = 100\text{ pF}$	10		80	
		High Speed Mode, $C_b = 400\text{ pF}$	20		160	
$t_{fDA}$	Fall time of SDA signal	Standard Mode			250	ns
		Fast Mode	$20+0.1C_b$		250	
		High Speed Mode, $C_b = 100\text{ pF}$	10		80	
		High Speed Mode, $C_b = 400\text{ pF}$	20		160	
$t_{rCL}$	Rise time of SCL signal	Standard Mode			1000	ns
		Fast Mode	$20+0.1C_b$		300	
		High Speed Mode, $C_b = 100\text{ pF}$	10		40	
		High Speed Mode, $C_b = 400\text{ pF}$	20		80	
$t_{rCL1}$	Rise time of SCL signal after a repeated start condition and after an acknowledge bit.	Standard Mode			1000	ns
		Fast Mode	$20+0.1C_b$		300	
		High Speed Mode, $C_b = 100\text{ pF}$	10		80	
		High Speed Mode, $C_b = 400\text{ pF}$	20		160	
$t_{fCL}$	Fall time of a SCL signal	Standard Mode			300	ns
		Fast Mode	$20+0.1C_b$		300	
		High Speed Mode, $C_b = 100\text{ pF}$	10		40	
		High Speed Mode, $C_b = 400\text{ pF}$	20		80	
$C_b$	Capacitive load for each bus line (SCL and SDA)				400	pF
$t_{SP}$	Pulse Width of spike suppressed <sup>(6)(4)</sup>	Fast Mode			50	ns
		High Speed Mode			10	
$t_{outz}$	SDA output delay (see the <a href="#">Additional Timing Information</a> section)	Fast Mode		87	270	ns
		High Speed Mode		38	60	

(6) Spike suppression filtering on SCL and SDA will suppress spikes that are less than 50 ns for standard-fast mode and less than 10ns for hs-mode.

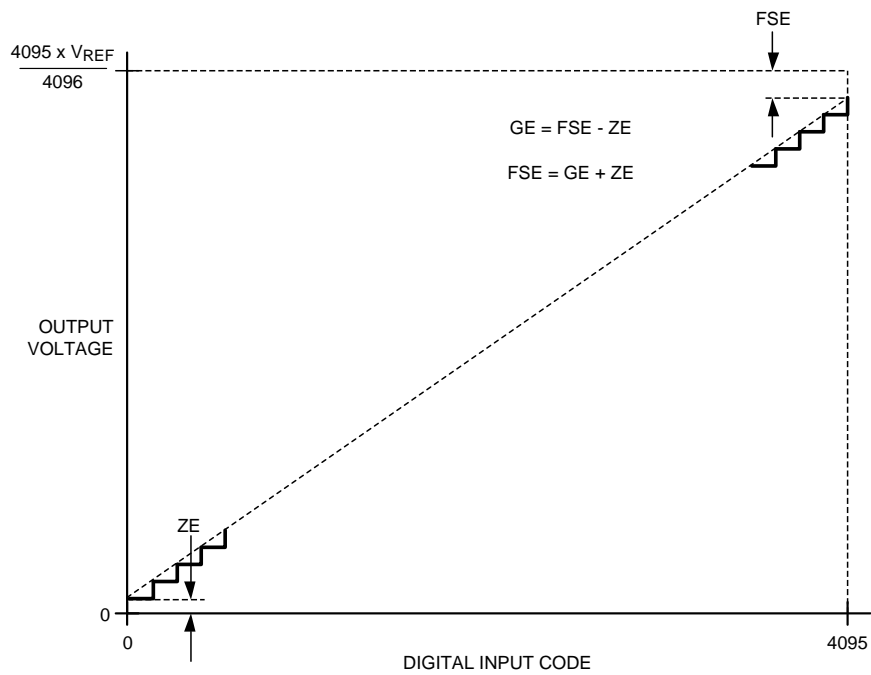

Figure 1. Input / Output Transfer Characteristic

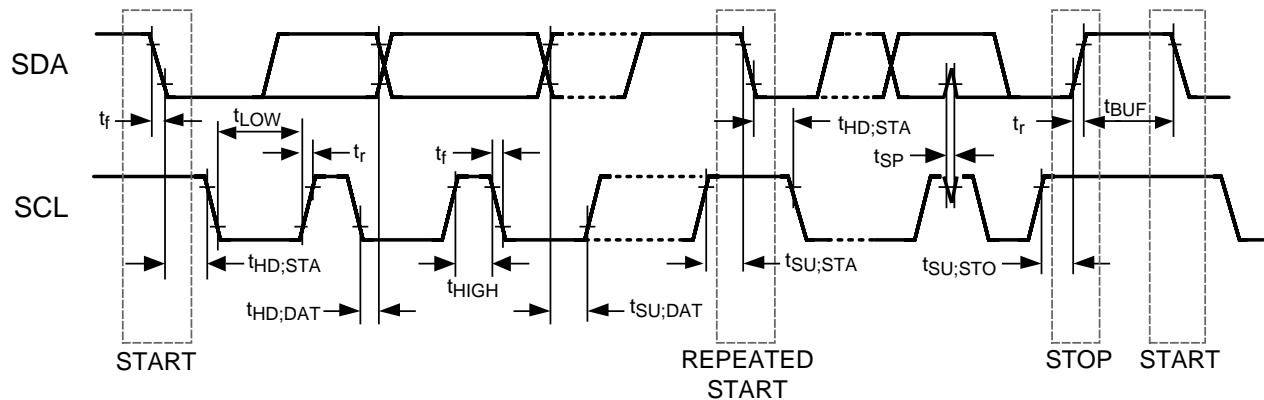
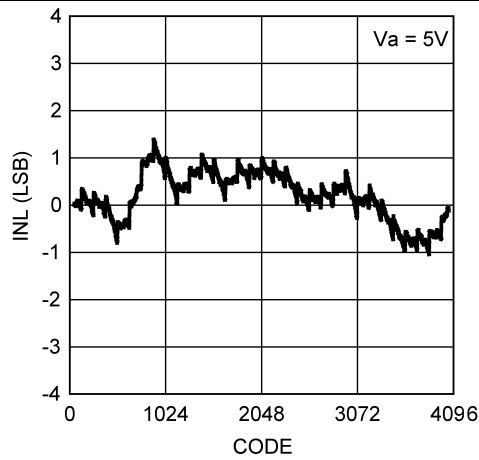
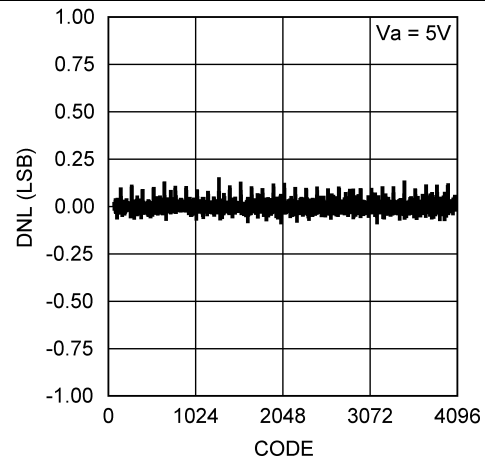
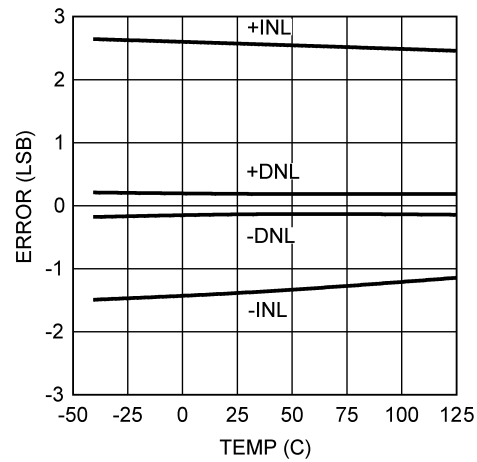
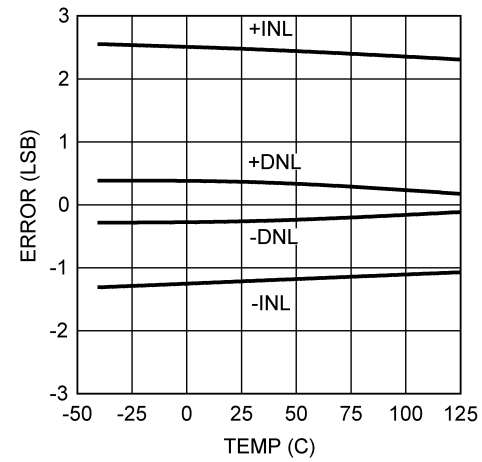
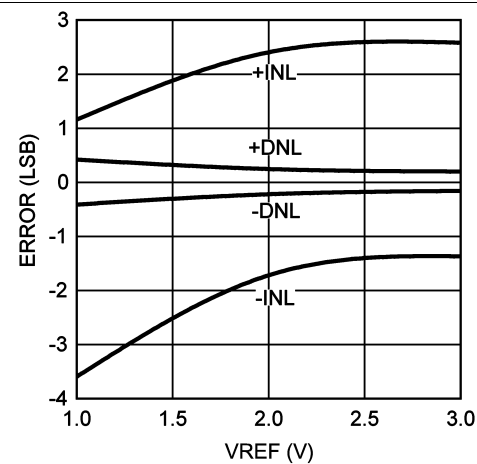
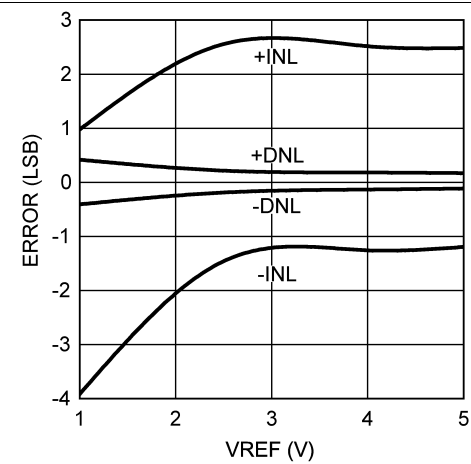

Figure 2. Serial Timing Diagram

## 7.7 Typical Characteristics

$V_{REF} = V_A$ ,  $f_{SCL} = 3.4$  MHz,  $T_A = 25^\circ\text{C}$ , Input Code Range 48 to 4047, unless otherwise stated.

**Figure 3. INL**

**Figure 4. DNL**

**Figure 5. INL/DNL vs Temperature at  $V_A = 3$  V**

**Figure 6. INL/DNL vs Temperature at  $V_A = 5$  V**

**Figure 7. INL/DNL vs  $V_{REFIN}$  at  $V_A = 3$  V**

**Figure 8. INL/DNL vs  $V_{REFIN}$  at  $V_A = 5$  V**

Typical Characteristics (continued)

$V_{REF} = V_A$ ,  $f_{SCL} = 3.4 \text{ MHz}$ ,  $T_A = 25^\circ\text{C}$ , Input Code Range 48 to 4047, unless otherwise stated.

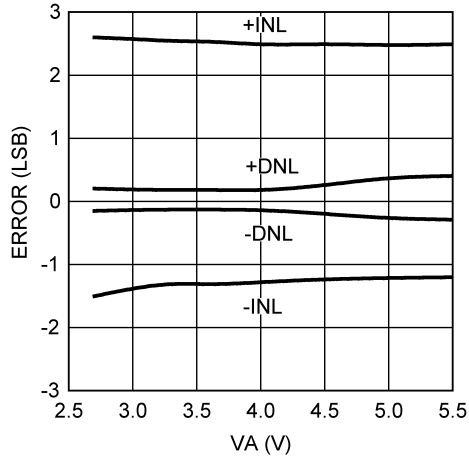

Figure 9. INL/DNL vs  $V_A$

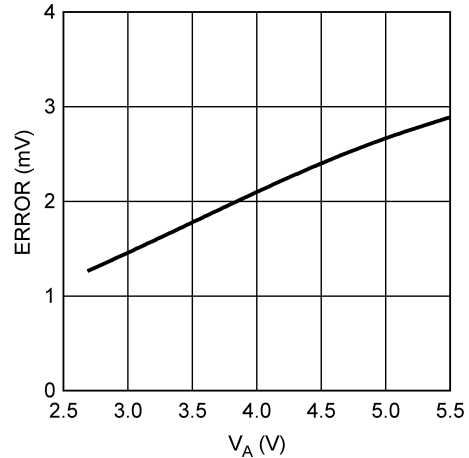

Figure 10. Zero Code Error vs  $V_A$

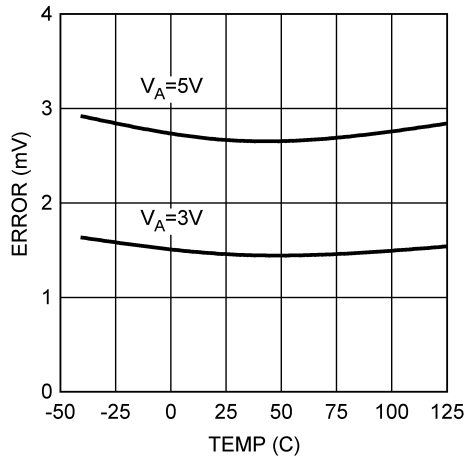

Figure 11. Zero Code Error vs Temperature

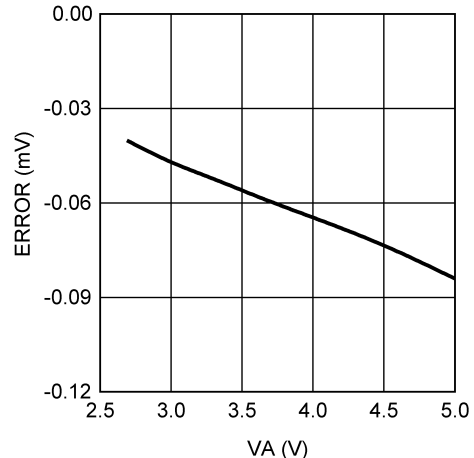

Figure 12. Full Scale Error vs  $V_A$

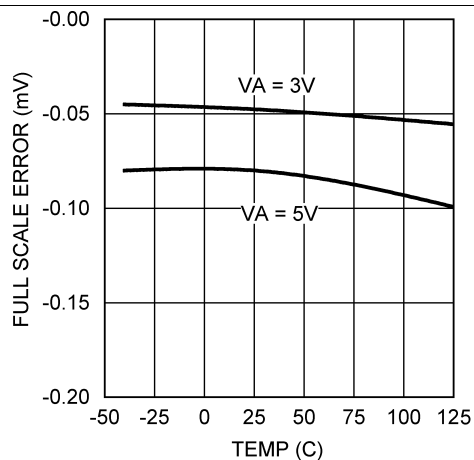

Figure 13. Full Scale Error vs Temperature

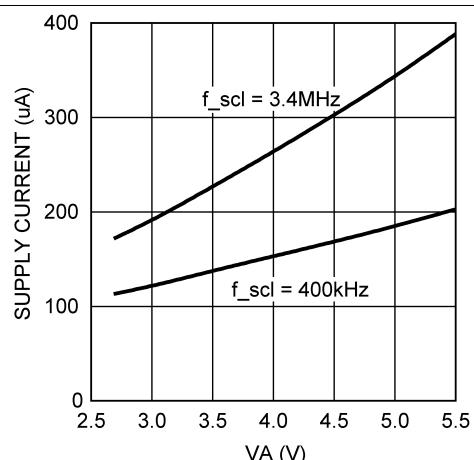

Figure 14. Total Supply Current vs  $V_A$

Typical Characteristics (continued)

$V_{REF} = V_A$ ,  $f_{SCL} = 3.4 \text{ MHz}$ ,  $T_A = 25^\circ\text{C}$ , Input Code Range 48 to 4047, unless otherwise stated.

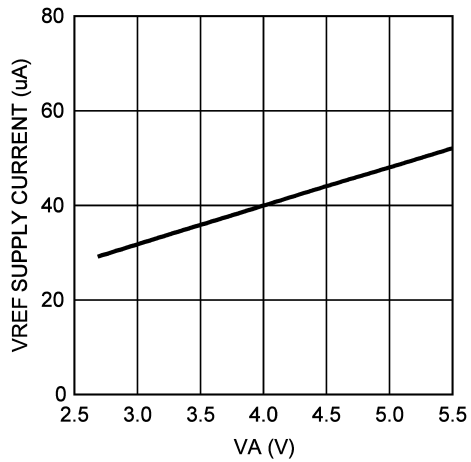

Figure 15.  $V_{REF}$  Supply Current vs  $V_A$

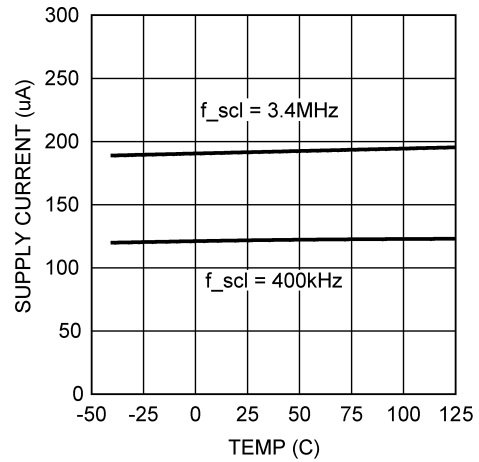

Figure 16. Total Supply Current vs Temperature at  $V_A = 3 \text{ V}$

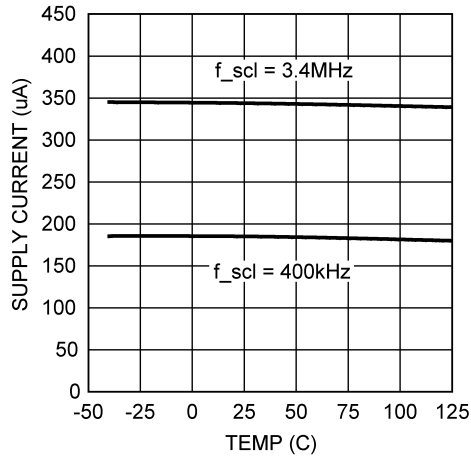

Figure 17. Total Supply Current vs Temperature at  $V_A = 5 \text{ V}$

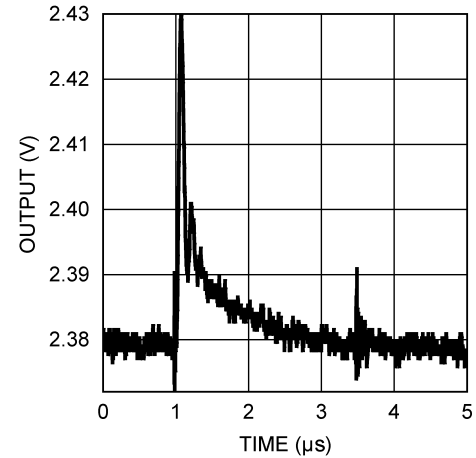

Figure 18. 5-V Glitch Response

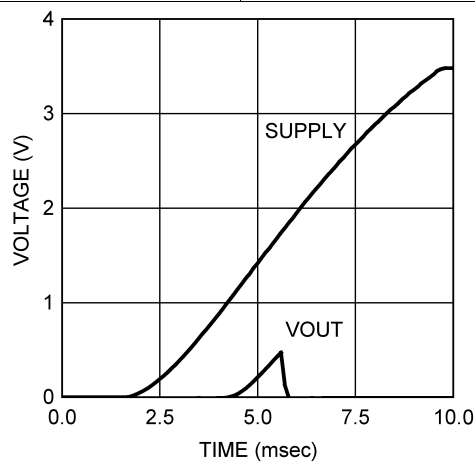

Figure 19. Power-On Reset

## 8 Detailed Description

### 8.1 Overview

The DAC121C081 is fabricated on a CMOS process with an architecture that consists of switches and resistor strings that are followed by an output buffer.

### 8.2 Functional Block Diagram

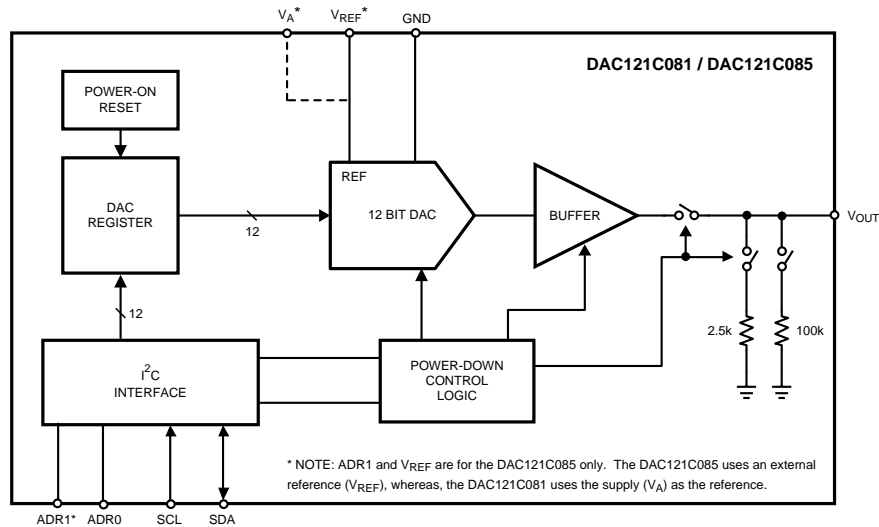

### 8.3 Feature Description

#### 8.3.1 DAC Section

The DAC121C081 is fabricated on a CMOS process with an architecture that consists of switches and resistor strings that are followed by an output buffer.

For simplicity, a single resistor string is shown in [Figure 20](#). This string consists of 4096 equal valued resistors with a switch at each junction of two resistors, plus a switch to ground. The code loaded into the DAC register determines which switch is closed, connecting the proper node to the amplifier. The input coding is straight binary with an ideal output voltage of:

$$V_{OUT} = V_{REF} \times (D / 4096)$$

where  $D$  is the decimal equivalent of the binary code that is loaded into the DAC register. (1)

$D$  can take on any integer value from 0 to 4095. This configuration ensures that the DAC is monotonic.

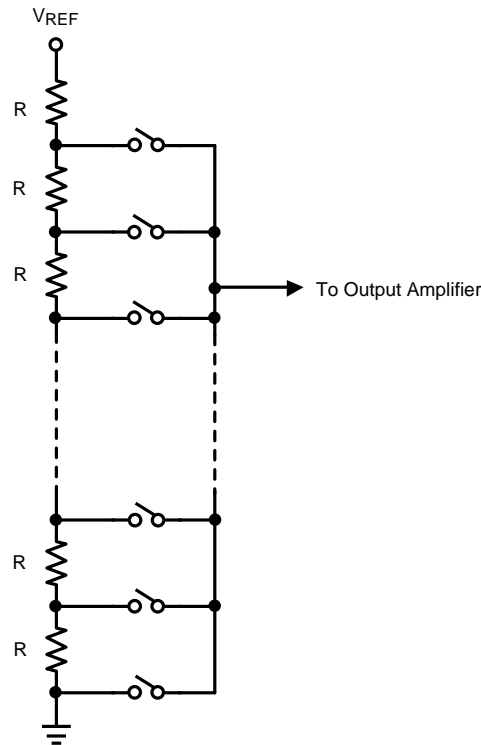
**Feature Description (continued)**

**Figure 20. DAC Resistor String**
**8.3.2 Output Amplifier**

The output amplifier is rail-to-rail, providing an output voltage range of 0 V to  $V_A$  when the reference is  $V_A$ . All amplifiers, even rail-to-rail types, exhibit a loss of linearity as the output approaches the supply rails (0 V and  $V_A$ , in this case). For this reason, linearity is specified over less than the full output range of the DAC. However, if the reference is less than  $V_A$ , there is only a loss in linearity in the lowest codes. The output capabilities of the amplifier are described in the [Electrical Characteristics](#).

The output amplifiers are capable of driving a load of 2 k $\Omega$  in parallel with 1500 pF to ground or to  $V_A$ . The zero-code and full-scale outputs for given load currents are available in the [Electrical Characteristics](#).

**8.3.3 Reference Voltage**

The DAC121C081 uses the supply ( $V_A$ ) as the reference. With that said,  $V_A$  must be treated as a reference. The analog output is only as clean as the reference ( $V_A$ ). TI recommends driving the reference with a voltage source with low-output impedance.

The DAC121C085 comes with an external reference supply pin ( $V_{REF}$ ). For the DAC121C085, it is important that  $V_{REF}$  be kept as clean as possible.

[Applications Information](#) describes a handful of ways to drive the reference appropriately. See [Using References as Power Supplies](#) for details.



## Feature Description (continued)

### 8.3.4 Serial Interface

The I<sup>2</sup>C-compatible interface operates in all three speed modes. Standard mode (100 kHz) and Fast mode (400 kHz) are functionally the same and will be referred to as Standard-Fast mode in this document. High-Speed mode (3.4MHz) is an extension of Standard-Fast mode and will be referred to as Hs-mode in this document. The following diagrams describe the timing relationships of the clock (SCL) and data (SDA) signals. Pullup resistors or current sources are required on the SCL and SDA busses to pull them high when they are not being driven low. A logic zero is transmitted by driving the output low. A logic high is transmitted by releasing the output and allowing it to be pulled up externally. The appropriate pullup resistor values depends on the total bus capacitance and operating speed.

#### 8.3.4.1 Basic I<sup>2</sup>C Protocol

The I<sup>2</sup>C interface is bi-directional and allows multiple devices to operate on the same bus. To facilitate this bus configuration, each device has a unique hardware address which is referred to as the slave address. To communicate with a particular device on the bus, the controller (master) sends the slave address and listens for a response from the slave. This response is referred to as an acknowledge bit. If a slave on the bus is addressed correctly, it Acknowledges (ACKs) the master by driving the SDA bus low. If the address doesn't match a device's slave address, it Not-acknowledges (NACKs) the master by letting SDA be pulled high. ACKs also occur on the bus when data is being transmitted. When the master is writing data, the slave ACKs after every data byte is successfully received. When the master is reading data, the master ACKs after every data byte is received to let the slave know it wants to receive another data byte. When the master wants to stop reading, it NACKs after the last data byte and creates a Stop condition on the bus.

All communication on the bus begins with either a Start condition or a Repeated Start condition. The protocol for starting the bus varies between Standard-Fast mode and Hs-mode. In Standard-Fast mode, the master generates a Start condition by driving SDA from high to low while SCL is high. In Hs-mode, starting the bus is more complicated. See [High-Speed \(Hs\) Mode](#) for the full details of a Hs-mode Start condition. A Repeated Start is generated to either address a different device, or switch between read and write modes. The master generates a Repeated Start condition by driving SDA low while SCL is high. Following the Repeated Start, the master sends out the slave address and a read/write bit as shown in [Figure 21](#). The bus continues to operate in the same speed mode as before the Repeated Start condition.

All communication on the bus ends with a Stop condition. In either Standard-Fast mode or Hs-Mode, a Stop condition occurs when SDA is pulled from low to high while SCL is high. After a Stop condition, the bus remains idle until a master generates a Start condition.

See the Phillips I<sup>2</sup>C<sup>®</sup> Specification (Version 2.1 Jan, 2000) for a detailed description of the serial interface.

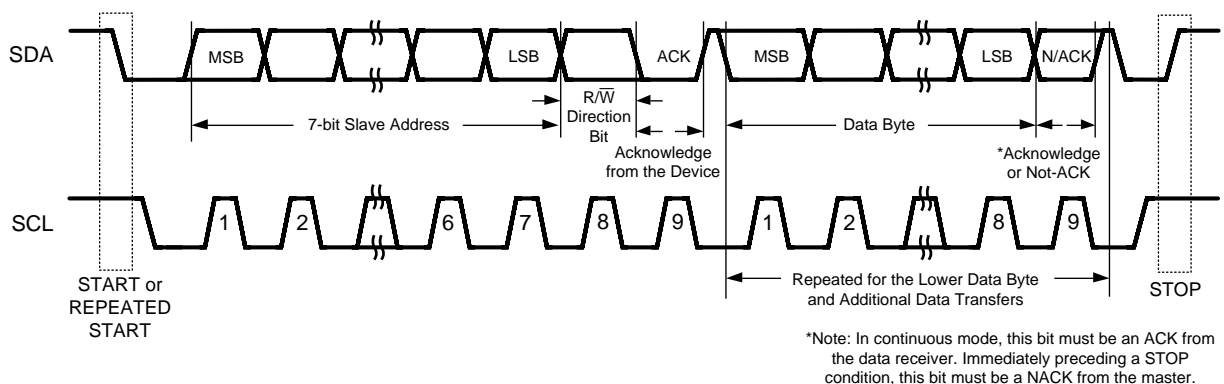

Figure 21. Basic Operation

## Feature Description (continued)

### 8.3.4.2 Standard-Fast Mode

In Standard-Fast mode, the master generates a start condition by driving SDA from high to low while SCL is high. The Start condition is always followed by a 7-bit slave address and a Read/Write bit. After these eight bits have been transmitted by the master, SDA is released by the master and the DAC121C081 either ACKs or NACKs the address. If the slave address matches, the DAC121C081 ACKs the master. If the address doesn't match, the DAC121C081 NACKs the master.

For a **write** operation, the master follows the ACK by sending the upper eight data bits to the DAC121C081. Then the DAC121C081 ACKs the transfer by driving SDA low. Next, the lower eight data bits are sent by the master. The DAC121C081 then ACKs the transfer. At this point, the DAC output updates to reflect the contents of the 16-bit DAC register. Next, the master either sends another pair of data bytes, generates a Stop condition to end communication, or generates a Repeated Start condition to communicate with another device on the bus.

For a **read** operation, the DAC121C081 sends out the upper eight data bits of the DAC register. This is followed by an ACK by the master. Next, the lower eight data bits of the DAC register are sent to the master. The master then produces a NACK by letting SDA be pulled high. The NACK is followed by a master-generated Stop condition to end communication on the bus, or a Repeated Start to communicate with another device on the bus.

### 8.3.4.3 High-Speed (Hs) Mode

For Hs-mode, the sequence of events to begin communication differ slightly from Standard-Fast mode. [Figure 22](#) describes this in further detail. Initially, the bus begins running in Standard-Fast mode. The master generates a Start condition and sends the 8-bit Hs master code (00001XXX) to the DAC121C081. Next, the DAC121C081 responds with a NACK. Once the SCL line has been pulled to a high level, the master switches to Hs-mode by increasing the bus speed and generating a Repeated Start condition (driving SDA low while SCL is pulled high). At this point, the master sends the slave address to the DAC121C081, and communication continues as shown in [Figure 21](#).

When the master generates a Repeated Start condition while in Hs-mode, the bus stays in Hs-mode awaiting the slave address from the master. The bus continues to run in Hs-mode until a Stop condition is generated by the master. When the master generates a Stop condition on the bus, the bus must be started in Standard-Fast mode again before increasing the bus speed and switching to Hs-mode. ns16705

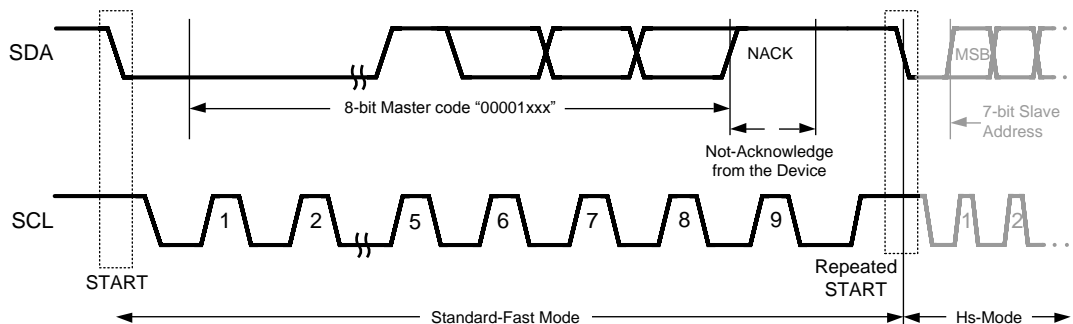

**Figure 22. Beginning Hs-Mode Communication**

### 8.3.4.4 I<sup>2</sup>C Slave (Hardware) Address

The DAC has a seven-bit I<sup>2</sup>C slave address. For the VSSOP version of the DAC, this address is configured by the ADR0 and ADR1 address selection inputs. For the DAC121C081, the address is configured by the ADR0 address selection input. ADR0 and ADR1 can be grounded, left floating, or tied to  $V_A$ . If desired, the address selection inputs can be set to  $V_A/2$  rather than left floating. The state of these inputs sets the address the DAC responds to on the I<sup>2</sup>C bus (see [Table 1](#)). In addition to the selectable slave address, there is also a broadcast address (1001000) for all DAC121C081's and DAC121C085's on the 2-wire bus. When the bus is addressed by the broadcast address, all the DAC121C081's and DAC121C085's will respond and update synchronously. [Figure 24](#) and [Figure 25](#) describe how the master device should address the DAC through the I<sup>2</sup>C-Compatible interface.

## Feature Description (continued)

Keep in mind that the address selection inputs (ADR0 and ADR1) are only sampled until the DAC is correctly addressed with a non-broadcast address. At this point, the ADR0 and ADR1 inputs TRI-STATE and the slave address is locked. Changes to ADR0 and ADR1 will not update the selected slave address until the device is power-cycled.

**Table 1. Slave Addresses**

Slave Address [A6 - A0]	DAC121C085 (VSSOP)		DAC121C081 (SOT AND WSON) <sup>(1)</sup>	Do Not Use <sup>(2)</sup>
	ADR1	ADR0	ADR0	
0001100	Floating	Floating	Floating	1000110
0001101	Floating	GND	GND	1000110
0001110	Floating	V <sub>A</sub>	V <sub>A</sub>	1000111
0001000	GND	Floating	-----	1000100
0001001	GND	GND	-----	1000100
0001010	GND	V <sub>A</sub>	-----	1000101
1001100	V <sub>A</sub>	Floating	-----	1100110
1001101	V <sub>A</sub>	GND	-----	1100110
1001110	V <sub>A</sub>	V <sub>A</sub>	-----	1100111
1001000	----- Broadcast Address -----			1100100

(1) Pin-compatible alternatives to the DAC121C081 options are available with additional address options.

(2) These addresses should not be used by other I<sup>2</sup>C devices on the I<sup>2</sup>C bus. Using these addresses can cause the DAC121C081/085 to not respond when addressed by the assigned Slave Address.

### 8.3.5 Power-On Reset

The power-on reset circuit controls the output voltage of the DAC during power up. Upon application of power, the DAC register is filled with zeros and the output voltage is 0 V. The output remains at 0 V until a valid write sequence is made to the DAC.

When resetting the device, it is crucial that the V<sub>A</sub> supply be lowered to a maximum of 200 mV before the supply is raised again to power up the device. Dropping the supply to within 200 mV of GND during a reset will ensure the ADC performs as specified.

### 8.3.6 Simultaneous Reset

The broadcast address allows the I<sup>2</sup>C master to write a single word to multiple DACs simultaneously. Provided that all of the DACs exist on a single I<sup>2</sup>C bus, every DAC updates when the broadcast address is used to address the bus. This feature allows the master to reset all of the DACs on a shared I<sup>2</sup>C bus to a specific digital code. For instance, if the master writes a power-down code to the bus with the broadcast address, all of the DACs powers down simultaneously.

### 8.3.7 Additional Timing Information: t<sub>outz</sub>

The t<sub>outz</sub> specification is provided to aid the design of the I<sup>2</sup>C bus. After the SCL bus is driven low by the I<sup>2</sup>C master, the SDA bus will be held for a short time by the DAC121C081. This time is referred to as t<sub>outz</sub>. The following figure illustrates the relationship between the fall of SCL, at the 30% threshold, to the time when the DAC begins to transition the SDA bus. The t<sub>outz</sub> specification only applies when the DAC is in control of the SDA bus. The DAC is only in control of the bus during an ACK by the DAC121C081 or a data byte read from the DAC (see [Figure 25](#)).

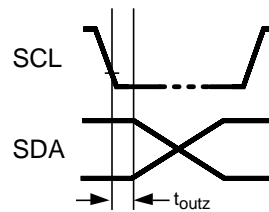
**Figure 23. Data Output Timing**

The  $t_{outz}$  specification is typically 87 ns in Standard-Fast Mode and 38 ns in Hs-Mode.

## 8.4 Device Functional Modes

### 8.4.1 Power-Down Modes

The DAC121C081 has three power-down modes. In power-down mode, the supply current drops to 0.13  $\mu\text{A}$  at 3 V and 0.15  $\mu\text{A}$  at 5 V (typical). The DAC121C081 is put into power-down mode by writing a one to PD1 and/or PD0. The outputs can be set to high impedance, terminated by 2.5 k $\Omega$  to GND, or terminated by 100 k $\Omega$  to GND (see [Figure 26](#)).

The bias generator, output amplifier, resistor string, and other linear circuitry are all shut down in any of the power-down modes. When the DAC121C081 is powered down, the value written to the DAC register, including the power-down bits, is saved. While the DAC is in power-down, the saved DAC register contents can be read back. When the DAC is brought out of power-down mode, the DAC register contents will be overwritten and  $V_{OUT}$  will be updated with the new 12-bit data value.

The time to exit power-down (Wake-Up Time) is typically 0.8  $\mu\text{s}$  at 3 V and 0.5  $\mu\text{s}$  at 5 V.

## 8.5 Programming

### 8.5.1 Writing to the DAC Register

To write to the DAC, the master addresses the part with the correct slave address (A6-A0) and writes a zero to the read/write bit. If addressed correctly, the DAC returns an ACK to the master. The master then sends out the upper data byte. The DAC responds by sending an ACK to the master. Next, the master sends the lower data byte to the DAC. The DAC responds by sending an ACK again. At this point, the master either sends the upper byte of the next data word to be converted by the DAC, generates a Stop condition to end communication, or generates a Repeated Start condition to begin communication with another device on the bus. Until generating a Stop condition, the master can continuously write the upper and lower data bytes to the DAC register. This allows for a maximum DAC conversion rate of 188.9 kilo-conversions per second in Hs-mode.

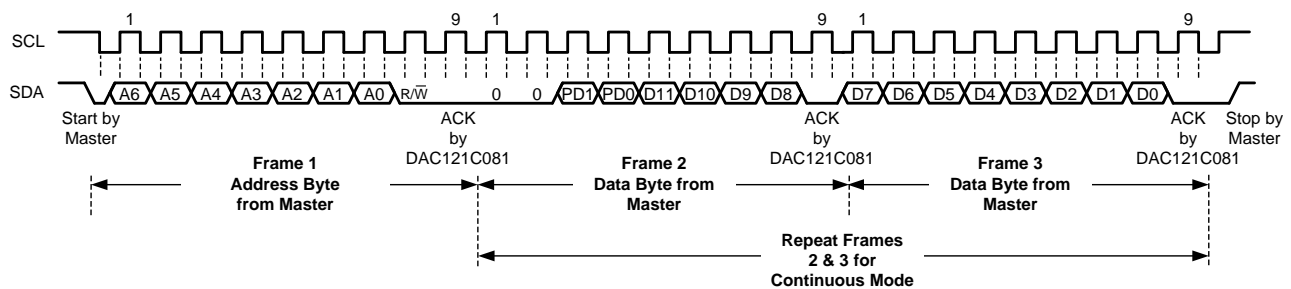
**Figure 24. Typical Write to the DAC Register**

## Programming (continued)

### 8.5.2 Reading from the DAC Register

To read from the DAC register, the master addresses the part with the correct slave address (A6-A0) and writes a one to the read/write bit. If addressed correctly, the DAC returns an ACK to the master. Next, the DAC sends out the upper data byte. The master responds by sending an ACK to the DAC to indicate that it wants to receive another data byte. Then the DAC sends the lower data byte to the master. Assuming only one 16-bit data word is read, the master sends a NACK after receiving the lower data byte. At this point, the master either generates a Stop condition to end communication, or a Repeated Start condition to begin communication with another device on the bus.

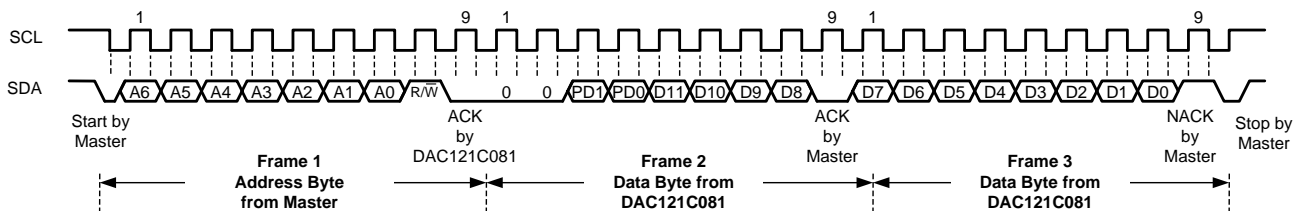

Figure 25. Typical Read from the DAC Register

## 8.6 Registers

### 8.6.1 DAC Register

The DAC register, Figure 26, has sixteen bits. The first two bits are always zero. The next two bits determine the mode of operation (normal mode or one of three power-down modes). The final twelve bits of the shift register are the data bits. The data format is straight binary (MSB first, LSB last), with twelve 0s corresponding to an output of 0 V and twelve 1s corresponding to a full-scale output of  $V_A - 1$  LSB. When writing to the DAC Register,  $V_{OUT}$  will update on the rising edge of the ACK following the lower data byte.

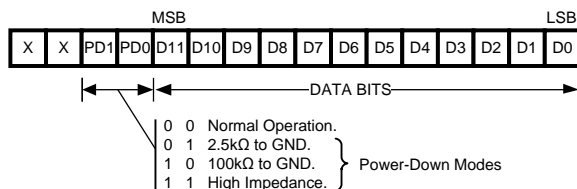

Figure 26. DAC Register Contents

## 9 Application and Implementation

### NOTE

Information in the following applications sections is not part of the TI component specification, and TI does not warrant its accuracy or completeness. TI's customers are responsible for determining suitability of components for their purposes. Customers should validate and test their design implementation to confirm system functionality.

### 9.1 Application Information

#### 9.1.1 Bipolar Operation

The DAC121C081 is designed for single supply operation and thus has a unipolar output. However, a bipolar output may be obtained with the circuit in [Figure 27](#). This circuit provides an output voltage range of  $\pm 5$  V. A rail-to-rail amplifier should be used if the amplifier supplies are limited to  $\pm 5$  V.

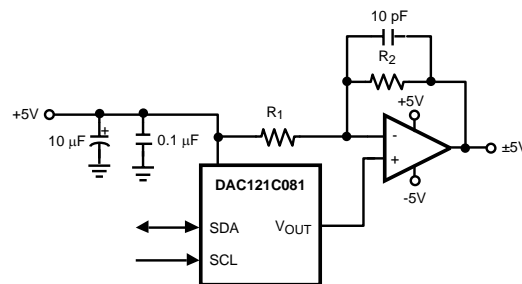

**Figure 27. Bipolar Operation**

The output voltage of this circuit for any code is found to be, as shown in [Equation 2](#):

$$V_O = (V_A \times (D / 4096) \times ((R_1 + R_2) / R_1) - V_A \times R_2 / R_1) \quad (2)$$

where D is the input code in decimal form.

[Equation 3](#) shows that with  $V_A = 5$  V and  $R_1 = R_2$ ,

$$V_O = (10 \times D / 4096) - 5 \text{ V} \quad (3)$$

A list of rail-to-rail amplifiers suitable for this application are indicated in [Table 2](#).

**Table 2. Some Rail-to-Rail Amplifiers**

AMP	PKGS	Typ $V_{OS}$	Typ $I_{SUPPLY}$
LMP7701	SOT-23	37 $\mu$ V	0.79 mA
LMV841	SC70-5	50 $\mu$ V	1 mA
LMC7111	SOT-23	0.9 mV	25 $\mu$ A
LM7301	SO-8, SOT-23	0.03 mV	620 $\mu$ A
LM8261	SOT-23	0.7 mV	1 mA

## 9.1.2 DSP/Microprocessor Interfacing

Interfacing the DAC121C081 to microprocessors and DSPs is quite simple. The following guidelines are offered to simplify the design process.

### 9.1.2.1 Interfacing to the 2-wire Bus

Figure 28 shows a microcontroller interfacing to the DAC121C081 through the 2-wire bus. Pullup resistors ( $R_p$ ) should be chosen to create an appropriate bus rise time and to limit the current that will be sunk by the open-drain outputs of the devices on the bus. See the I<sup>2</sup>C<sup>®</sup> Specification for further details. Typical pullup values to use in Standard-Fast mode bus applications are 2 k $\Omega$  to 10 k $\Omega$ . SCL and SDA series resistors ( $R_s$ ) near the DAC121C081 are optional. If high-voltage spikes are expected on the 2-wire bus, series resistors should be used to filter the voltage on SDA and SCL. The value of the series resistance must be picked to ensure the  $V_{IL}$  threshold can be achieved. If used,  $R_s$  is typically 51  $\Omega$ .

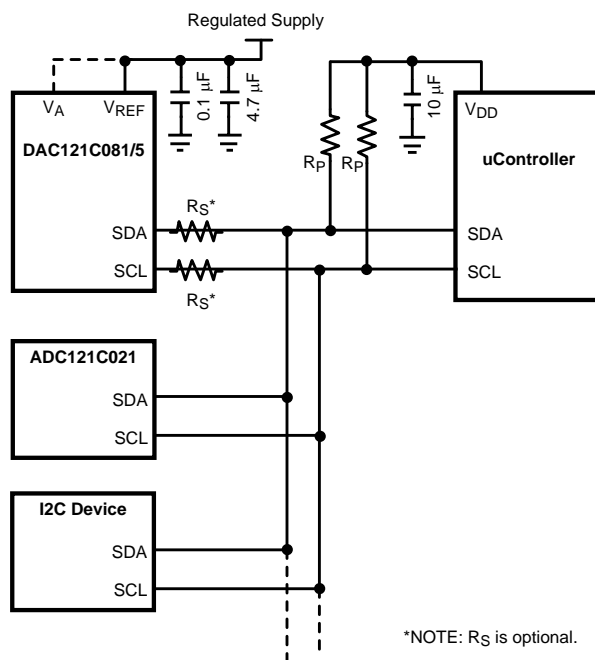
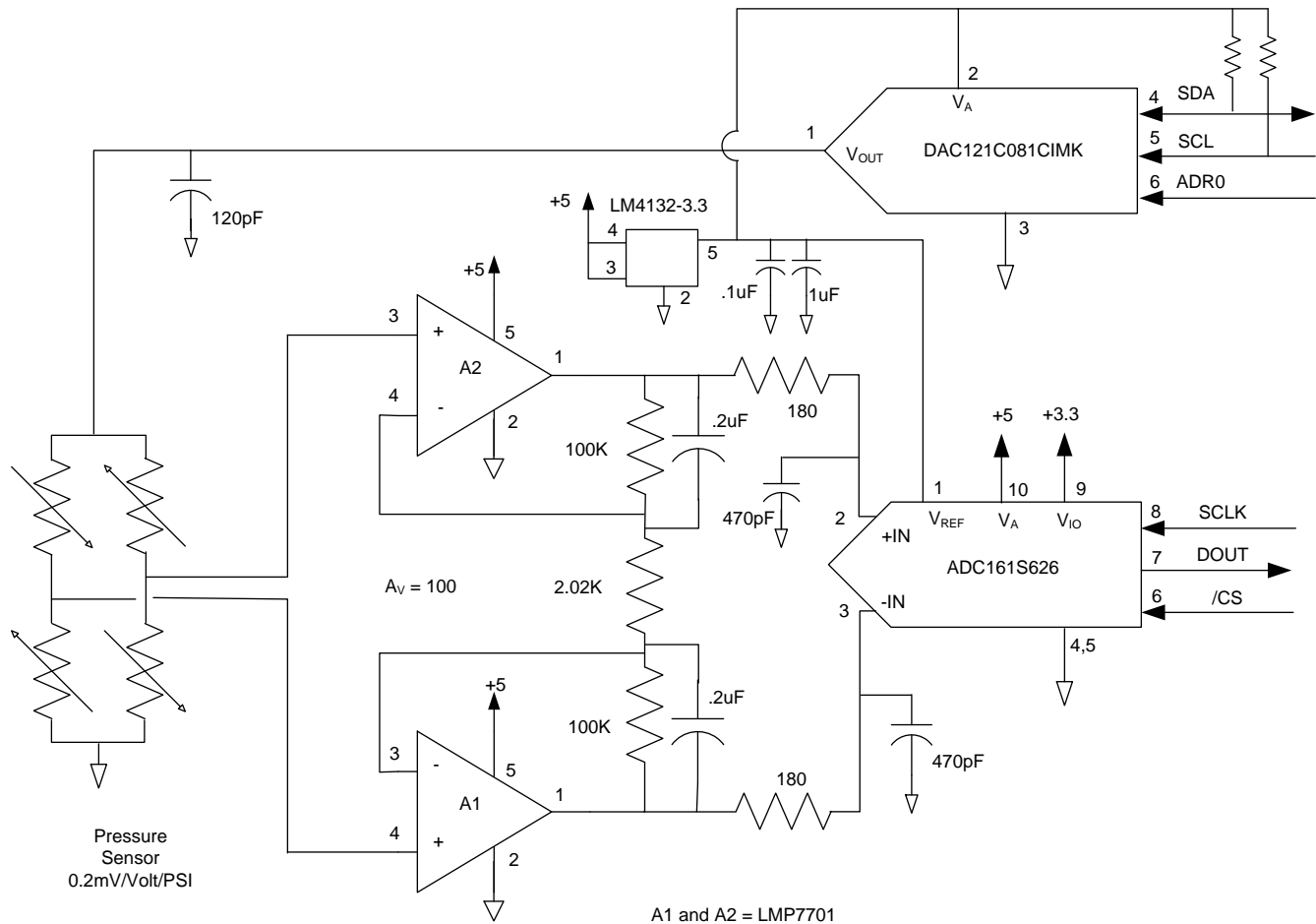

Figure 28. Serial Interface Connection Diagram

### 9.1.2.2 Interfacing to a Hs-mode Bus

Interfacing to a Hs-mode bus is very similar to interfacing to a Standard-Fast mode bus. In Hs-mode, the specified rise time of SCL is shortened. To create a faster rise time, the master device (microcontroller) can drive the SCL bus high and low. In other words, the microcontroller can drive the line high rather than leaving it to the pullup resistor. It is also possible to decrease the value of the pullup resistors or increase the pullup current to meet the tighter timing specs. See the I<sup>2</sup>C<sup>®</sup> Specification for further details.

## 9.2 Typical Application



**Figure 29. Pressure Sensor Gain Adjust**

### 9.2.1 Design Requirements

A positive supply only data acquisition system capable of digitizing a pressure sensor output. In addition to digitizing the pressure sensor output, the system designer can use the DAC121C081 to correct for gain errors in the pressure sensor output by adjusting the bias voltage to the bridge pressure sensor.

### 9.2.2 Detailed Design Procedure

As shown in Equation 4, the output of the pressure sensor is relative to the imbalance of the resistive bridge times the output of the DAC121C081, thus providing the desired gain correction.

$$\text{Pressure Sensor Output} = (\text{DAC\_Output} \times [(R2 / (R1 + R2) - (R4 / (R3 + R4))]) \quad (4)$$

Likewise for the ADC161S626, Equation 5 shows that the ADC output is function of the Pressure Sensor Output times relative to the ratio of the ADC input divided by the DAC121C081 output voltage.

$$\text{ADC161S626 Output} = (\text{Pressure Sensor Output} \times 100 / (2 \times VREF)) \times 2^{16} \quad (5)$$



**Typical Application (continued)**

**9.2.3 Application Curve**

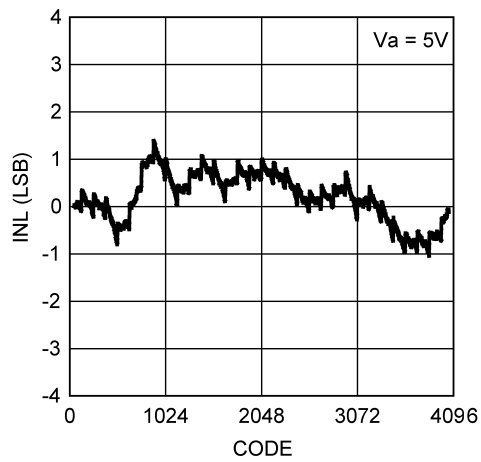

**Figure 30. INL vs Input Code**

## 10 Power Supply Recommendations

### 10.1 Using References as Power Supplies

While the simplicity of the DAC121C081 implies ease of use, it is important to recognize that the path from the reference input ( $V_A$  for the DAC121C081 and  $V_{REF}$  for the DAC121C085) to  $V_{OUT}$  will have essentially zero Power Supply Rejection Ratio (PSRR). Therefore, it is necessary to provide a noise-free supply voltage to the reference. To use the full dynamic range of the DAC121C085, the supply pin ( $V_A$ ) and  $V_{REF}$  can be connected together and share the same supply voltage. Because the DAC121C081 consumes very little power, a reference source may be used as the supply voltage. The advantages of using a reference source over a voltage regulator are accuracy and stability. Some low noise regulators can also be used. Listed below are a few reference and power supply options for the DAC121C081. When using the DAC121C081, it is important to treat the analog supply ( $V_A$ ) as the reference.

#### 10.1.1 LM4132

The LM4132, with its 0.05% accuracy over temperature, is a good choice as a reference source for the DAC121C081. The 4.096-V version is useful if a 0-V to 4.095-V output range is desirable or acceptable. Bypassing the LM4132  $V_{IN}$  pin with a 0.1- $\mu\text{F}$  capacitor and the  $V_{OUT}$  pin with a 2.2- $\mu\text{F}$  capacitor improves stability and reduces output noise. The LM4132 comes in a space-saving 5-pin SOT-23.

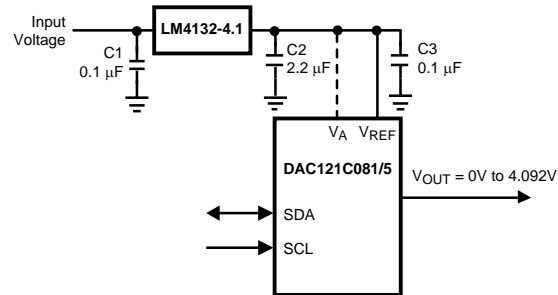

**Figure 31. The LM4132 as a Power Supply**

#### 10.1.2 LM4050

Available with accuracy of 0.44%, the LM4050 shunt reference is also a good choice as a reference for the DAC121C081. It is available in 4.096-V and 5-V versions and comes in a space-saving, 3-pin SOT-23.

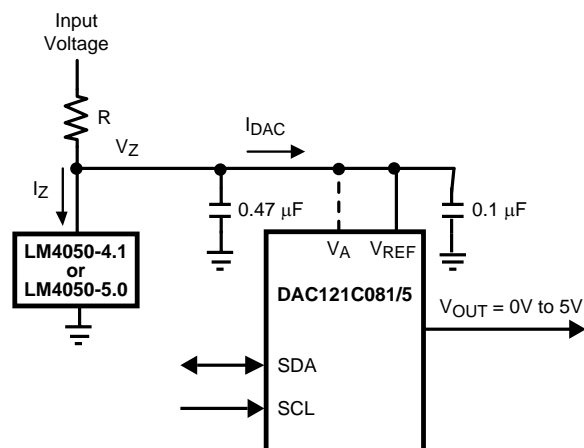

**Figure 32. The LM4050 as a Power Supply**

## Using References as Power Supplies (continued)

The minimum resistor value in the circuit of Figure 32 must be chosen such that the maximum current through the LM4050 does not exceed its 15-mA rating. The conditions for maximum current include the input voltage at its maximum, the LM4050 voltage at its minimum, and the DAC121C081 drawing zero current. The maximum resistor value must allow the LM4050 to draw more than its minimum current for regulation plus the maximum DAC121C081 current in full operation. The conditions for minimum current include the input voltage at its minimum, the LM4050 voltage at its maximum, the resistor value at its maximum due to tolerance, and the DAC121C081 draws its maximum current. These conditions can be summarized as

$$R(\text{min}) = (V_{\text{IN}}(\text{max}) - V_{\text{Z}}(\text{min})) / I_{\text{Z}}(\text{max})$$

where

- $V_{\text{Z}}(\text{min})$  is the nominal LM4050 output voltage  $\pm$  the LM4050 output tolerance over temperature.
- $I_{\text{Z}}(\text{max})$  is the maximum allowable current through the LM4050.

and

$$R(\text{max}) = (V_{\text{IN}}(\text{min}) - V_{\text{Z}}(\text{max})) / (I_{\text{DAC}}(\text{max}) + I_{\text{Z}}(\text{min}))$$

where

- $V_{\text{Z}}(\text{max})$  is the nominal LM4050 output voltage  $\pm$  the LM4050 output tolerance over temperature.
- $I_{\text{DAC}}(\text{max})$  is the maximum DAC121C081 supply current.
- $I_{\text{Z}}(\text{min})$  is the minimum current required by the LM4050 for proper regulation.

### 10.1.3 LP3985

The LP3985 is a low noise, ultra low dropout voltage regulator with a 3% accuracy over temperature. It is a good choice for applications that do not require a precision reference for the DAC121C081. It comes in 3-V, 3.3-V and 5-V versions, among others, and sports a low 30- $\mu$ V noise specification at low frequencies. Because low-frequency noise is relatively difficult to filter, this specification could be important for some applications. The LP3985 comes in a space-saving 5-pin SOT-23 and 5-bump DSBGA packages.

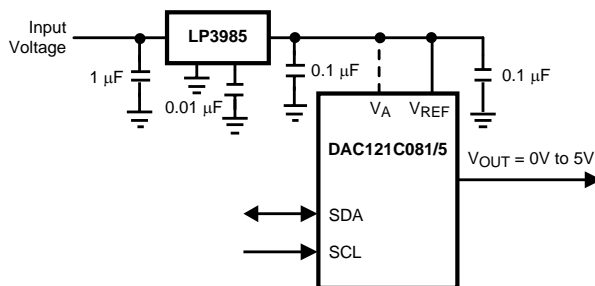

Figure 33. Using the LP3985 Regulator

An input capacitance of 1  $\mu$ F without any ESR requirement is required at the LP3985 input, while a 1- $\mu$ F ceramic capacitor with an ESR requirement of 5 m $\Omega$  to 500 m $\Omega$  is required at the output. Careful interpretation and understanding of the capacitor specification is required to ensure correct device operation.

### 10.1.4 LP2980

The LP2980 is an ultra low dropout regulator with a 0.5% or 1% accuracy over temperature, depending upon grade. It is available in 3-V, 3.3-V, and 5-V versions, among others.

## Using References as Power Supplies (continued)

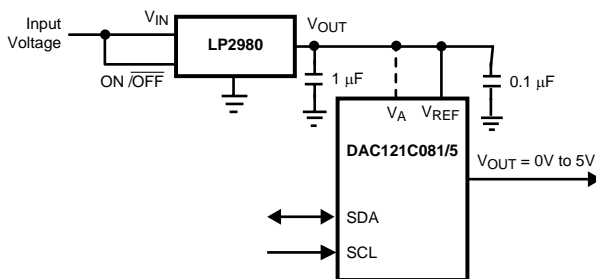

**Figure 34. Using the LP2980 Regulator**

Like any low dropout regulator, the LP2980 requires an output capacitor for loop stability. This output capacitor must be at least 1- $\mu$ F over temperature, but values of 2.2  $\mu$ F or more will provide even better performance. The ESR of this capacitor should be within the range specified in the LP2980 ([SNOS733](#)) data sheet. Surface-mount solid tantalum capacitors offer a good combination of small size and ESR. Ceramic capacitors are attractive due to their small size but generally have ESR values that are too low for use with the LP2980. Aluminum electrolytic capacitors are typically not a good choice due to their large size and have ESR values that may be too high at low temperatures.

## 11 Layout

### 11.1 Layout Guidelines

For best accuracy and minimum noise, the printed-circuit board containing the DAC121C081 should have separate analog and digital areas. The areas are defined by the locations of the analog and digital power planes. Both of these planes should be located on the same board layer. There should be a single ground plane. A single ground plane is preferred if digital return current does not flow through the analog ground area. Frequently a single ground plane design uses a *fencing* technique to prevent the mixing of analog and digital ground current. Separate ground planes should only be used when the fencing technique is inadequate. The separate ground planes must be connected in one place, preferably near the DAC121C081. Special care is required to ensure that digital signals with fast edge rates do not pass over split ground planes. They must always have a continuous return path below their traces.

The DAC121C081 power supply should be bypassed with a 4.7- $\mu\text{F}$  and a 0.1- $\mu\text{F}$  capacitor as close as possible to the device with the 0.1  $\mu\text{F}$  right at the device supply pin. The 4.7- $\mu\text{F}$  capacitor should be a tantalum type and the 0.1- $\mu\text{F}$  capacitor should be a low ESL, low ESR type. The power supply for the DAC121C081 should only be used for analog circuits.

Avoid crossover of analog and digital signals and keep the clock and data lines on the component side of the board. These clock and data lines should have controlled impedances.

### 11.2 Layout Example

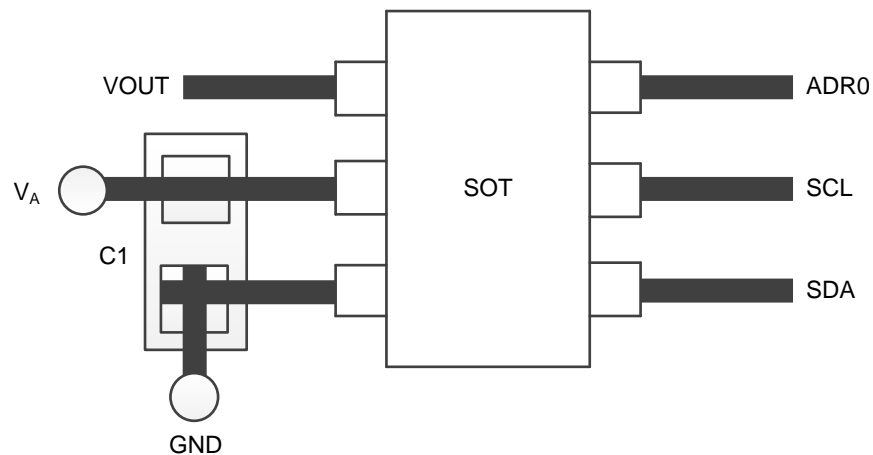

Figure 35. Layout Example

## 12 Device and Documentation Support

### 12.1 Device Support

#### 12.1.1 Device Nomenclature

##### 12.1.1.1 Specification Definitions

**DIFFERENTIAL NON-LINEARITY (DNL)** is the measure of the maximum deviation from the ideal step size of 1 LSB, which is  $V_{REF} / 4096 = V_A / 4096$ .

**DIGITAL FEEDTHROUGH** is a measure of the energy injected into the analog output of the DAC from the digital inputs when the DAC output is not updated. It is measured with a full-scale code change on the data bus.

**FULL-SCALE ERROR** is the difference between the actual output voltage with a full scale code (FFFh) loaded into the DAC and the value of  $V_A \times 4095 / 4096$ .

**GAIN ERROR** is the deviation from the ideal slope of the transfer function. It can be calculated from Zero and Full-Scale Errors as  $GE = FSE - ZE$ , where GE is Gain error, FSE is Full-Scale Error and ZE is Zero Error.

**GLITCH IMPULSE** is the energy injected into the analog output when the input code to the DAC register changes. It is specified as the area of the glitch in nanovolt-seconds.

**INTEGRAL NON-LINEARITY (INL)** is a measure of the deviation of each individual code from a straight line through the input-to-output transfer function. The deviation of any given code from this straight line is measured from the center of that code value. The end point method is used. INL for this product is specified over a limited range, per the [Electrical Characteristics](#).

**LEAST SIGNIFICANT BIT (LSB)** is the bit that has the smallest value or weight of all bits in a word. This value is

$$LSB = V_{REF} / 2^n$$

where  $V_{REF}$  is the supply voltage for this product, and  $n$  is the DAC resolution in bits, which is 12 for the DAC121C081. (8)

**MAXIMUM LOAD CAPACITANCE** is the maximum capacitance that can be driven by the DAC with output stability maintained.

**MONOTONICITY** is the condition of being monotonic, where the DAC has an output that never decreases when the input code increases.

**MOST SIGNIFICANT BIT (MSB)** is the bit that has the largest value or weight of all bits in a word. Its value is 1/2 of  $V_A$ .

**MULTIPLYING BANDWIDTH** is the frequency at which the output amplitude falls 3 dB below the input sine wave on  $V_{REFIN}$  with a full-scale code loaded into the DAC.

**POWER EFFICIENCY** is the ratio of the output current to the total supply current. The output current comes from the power supply. The difference between the supply and output currents is the power consumed by the device without a load.

**SETTLING TIME** is the time for the output to settle to within 1/2 LSB of the final value after the input code is updated.

**TOTAL HARMONIC DISTORTION (THD)** is the measure of the harmonics present at the output of the DACs with an ideal sine wave applied to  $V_{REFIN}$ . THD is measured in dB.

**WAKE-UP TIME** is the time for the output to exit power-down mode. This time is measured from the rising edge of SCL during the ACK bit of the lower data byte to the time the output voltage deviates from the power-down voltage of 0 V.

**ZERO CODE ERROR** is the output error, or voltage, present at the DAC output after a code of 000h has been entered.

## 12.2 Documentation Support

### 12.2.1 Related Documentation

For related documentation see the following:

- [LP2980-N Micropower 50 mA Ultra Low-Dropout Regulator In SOT-23 Package](#), SNOS733.

### 12.3 Related Links

The table below lists quick access links. Categories include technical documents, support and community resources, tools and software, and quick access to sample or buy.

**Table 3. Related Links**

PARTS	PRODUCT FOLDER	SAMPLE & BUY	TECHNICAL DOCUMENTS	TOOLS & SOFTWARE	SUPPORT & COMMUNITY
DAC121C081	<a href="#">Click here</a>	<a href="#">Click here</a>	<a href="#">Click here</a>	<a href="#">Click here</a>	<a href="#">Click here</a>
DAC121C085	<a href="#">Click here</a>	<a href="#">Click here</a>	<a href="#">Click here</a>	<a href="#">Click here</a>	<a href="#">Click here</a>

### 12.4 Trademarks

I<sup>2</sup>C is a registered trademark of Phillips Corporation..  
All other trademarks are the property of their respective owners.

### 12.5 Electrostatic Discharge Caution



These devices have limited built-in ESD protection. The leads should be shorted together or the device placed in conductive foam during storage or handling to prevent electrostatic damage to the MOS gates.

### 12.6 Glossary

[SLYZ022](#) — *TI Glossary*.

This glossary lists and explains terms, acronyms, and definitions.

## 13 Mechanical, Packaging, and Orderable Information

The following pages include mechanical, packaging, and orderable information. This information is the most current data available for the designated devices. This data is subject to change without notice and revision of this document. For browser-based versions of this data sheet, refer to the left-hand navigation.

**PACKAGING INFORMATION**

Orderable Device	Status (1)	Package Type	Package Drawing	Pins	Package Qty	Eco Plan (2)	Lead finish/ Ball material (6)	MSL Peak Temp (3)	Op Temp (°C)	Device Marking (4/5)	Samples
DAC121C081CIMK/NOPB	ACTIVE	SOT-23-THIN	DDC	6	1000	RoHS & Green	NIPDAU	Level-1-260C-UNLIM	-40 to 125	X84C	<a href="#">Samples</a>
DAC121C081CISD/NOPB	ACTIVE	WSON	NGF	6	1000	RoHS & Green	SN	Level-1-260C-UNLIM	-40 to 125	X87	<a href="#">Samples</a>
DAC121C081CISDX/NOPB	ACTIVE	WSON	NGF	6	4500	RoHS & Green	SN	Level-1-260C-UNLIM	-40 to 125	X87	<a href="#">Samples</a>
DAC121C085CIMM/NOPB	ACTIVE	VSSOP	DGK	8	1000	RoHS & Green	SN	Level-1-260C-UNLIM	-40 to 125	X90C	<a href="#">Samples</a>
DAC121C085CIMMX/NOPB	ACTIVE	VSSOP	DGK	8	3500	RoHS & Green	SN	Level-1-260C-UNLIM	-40 to 125	X90C	<a href="#">Samples</a>

(1) The marketing status values are defined as follows:

**ACTIVE:** Product device recommended for new designs.

**LIFEBUY:** TI has announced that the device will be discontinued, and a lifetime-buy period is in effect.

**NRND:** Not recommended for new designs. Device is in production to support existing customers, but TI does not recommend using this part in a new design.

**PREVIEW:** Device has been announced but is not in production. Samples may or may not be available.

**OBSELETE:** TI has discontinued the production of the device.

(2) **RoHS:** TI defines "RoHS" to mean semiconductor products that are compliant with the current EU RoHS requirements for all 10 RoHS substances, including the requirement that RoHS substance do not exceed 0.1% by weight in homogeneous materials. Where designed to be soldered at high temperatures, "RoHS" products are suitable for use in specified lead-free processes. TI may reference these types of products as "Pb-Free".

**RoHS Exempt:** TI defines "RoHS Exempt" to mean products that contain lead but are compliant with EU RoHS pursuant to a specific EU RoHS exemption.

**Green:** TI defines "Green" to mean the content of Chlorine (Cl) and Bromine (Br) based flame retardants meet JS709B low halogen requirements of <=1000ppm threshold. Antimony trioxide based flame retardants must also meet the <=1000ppm threshold requirement.

(3) MSL, Peak Temp. - The Moisture Sensitivity Level rating according to the JEDEC industry standard classifications, and peak solder temperature.

(4) There may be additional marking, which relates to the logo, the lot trace code information, or the environmental category on the device.

(5) Multiple Device Markings will be inside parentheses. Only one Device Marking contained in parentheses and separated by a "~" will appear on a device. If a line is indented then it is a continuation of the previous line and the two combined represent the entire Device Marking for that device.

(6) Lead finish/Ball material - Orderable Devices may have multiple material finish options. Finish options are separated by a vertical ruled line. Lead finish/Ball material values may wrap to two lines if the finish value exceeds the maximum column width.



**Important Information and Disclaimer:** The information provided on this page represents TI's knowledge and belief as of the date that it is provided. TI bases its knowledge and belief on information provided by third parties, and makes no representation or warranty as to the accuracy of such information. Efforts are underway to better integrate information from third parties. TI has taken and continues to take reasonable steps to provide representative and accurate information but may not have conducted destructive testing or chemical analysis on incoming materials and chemicals. TI and TI suppliers consider certain information to be proprietary, and thus CAS numbers and other limited information may not be available for release.

In no event shall TI's liability arising out of such information exceed the total purchase price of the TI part(s) at issue in this document sold by TI to Customer on an annual basis.

**TAPE AND REEL INFORMATION**

**QUADRANT ASSIGNMENTS FOR PIN 1 ORIENTATION IN TAPE**



\*All dimensions are nominal

Device	Package Type	Package Drawing	Pins	SPQ	Reel Diameter (mm)	Reel Width W1 (mm)	A0 (mm)	B0 (mm)	K0 (mm)	P1 (mm)	W (mm)	Pin1 Quadrant
DAC121C081CIMK/NOPB	SOT-23-THIN	DDC	6	1000	178.0	8.4	3.2	3.2	1.4	4.0	8.0	Q3
DAC121C081CISD/NOPB	WSON	NGF	6	1000	178.0	12.4	2.8	2.5	1.0	8.0	12.0	Q1
DAC121C081CISDX/NOPB	WSON	NGF	6	4500	330.0	12.4	2.8	2.5	1.0	8.0	12.0	Q1
DAC121C085CIMM/NOPB	VSSOP	DGK	8	1000	178.0	12.4	5.3	3.4	1.4	8.0	12.0	Q1
DAC121C085CIMMX/NOPB	VSSOP	DGK	8	3500	330.0	12.4	5.3	3.4	1.4	8.0	12.0	Q1

**TAPE AND REEL BOX DIMENSIONS**

\*All dimensions are nominal

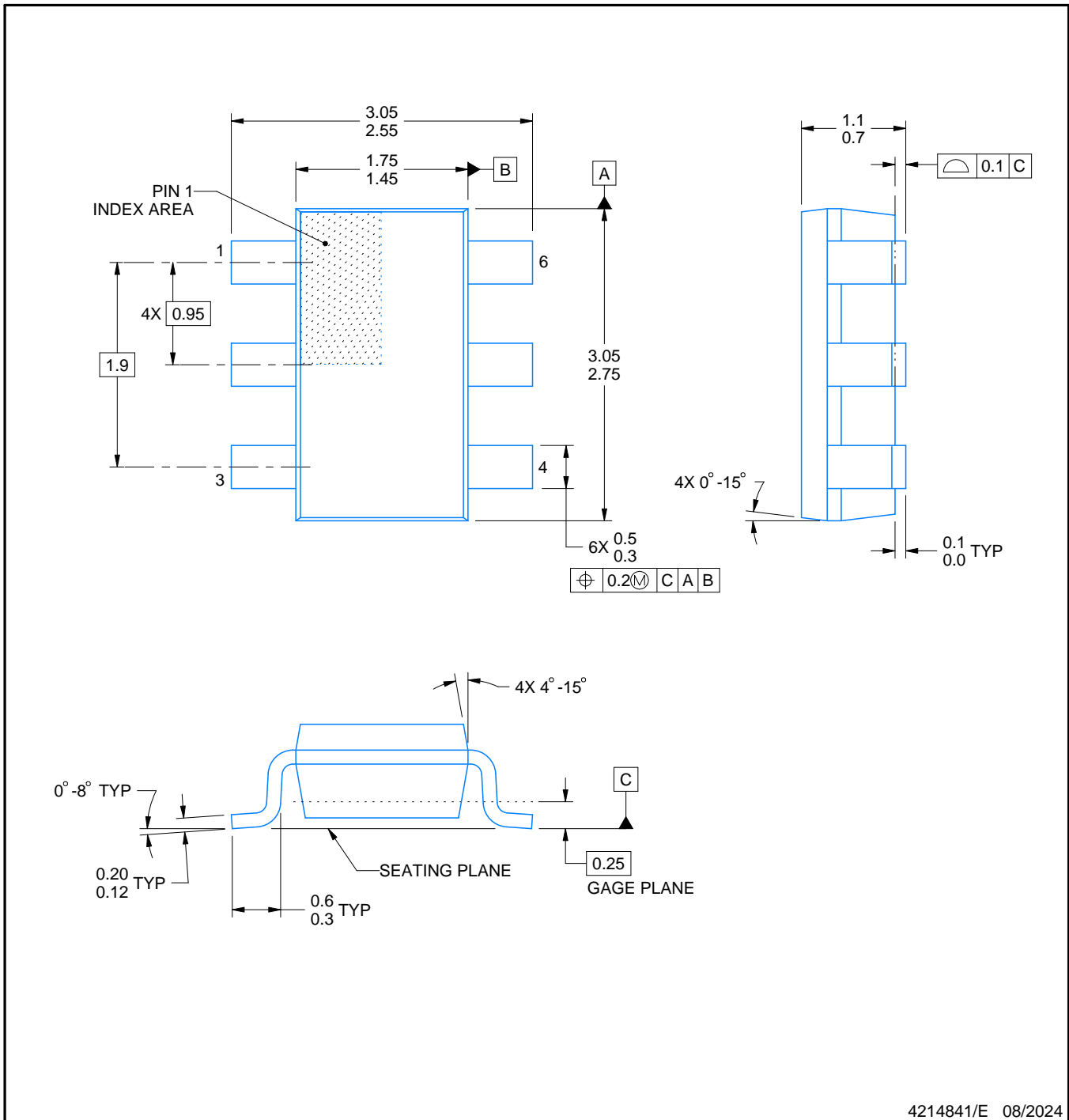
Device	Package Type	Package Drawing	Pins	SPQ	Length (mm)	Width (mm)	Height (mm)
DAC121C081CIMK/NOPB	SOT-23-THIN	DDC	6	1000	210.0	185.0	35.0
DAC121C081CISD/NOPB	WSON	NGF	6	1000	210.0	185.0	35.0
DAC121C081CISDX/ NOPB	WSON	NGF	6	4500	367.0	367.0	35.0
DAC121C085CIMM/NOPB	VSSOP	DGK	8	1000	210.0	185.0	35.0
DAC121C085CIMMX/ NOPB	VSSOP	DGK	8	3500	367.0	367.0	35.0



NOTES:

1. All linear dimensions are in millimeters. Any dimensions in parenthesis are for reference only. Dimensioning and tolerancing per ASME Y14.5M.
2. This drawing is subject to change without notice.
3. Reference JEDEC MO-193.

# EXAMPLE BOARD LAYOUT

DDC0006A

SOT-23 - 1.1 max height

SMALL OUTLINE TRANSISTOR

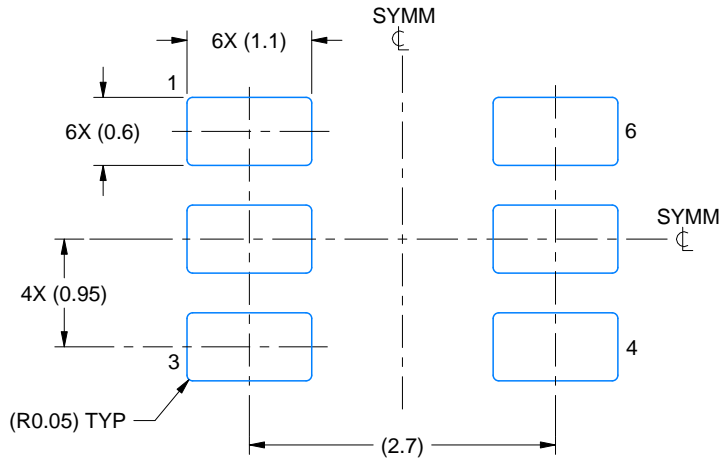

LAND PATTERN EXAMPLE  
EXPLODED METAL SHOWN  
SCALE:15X

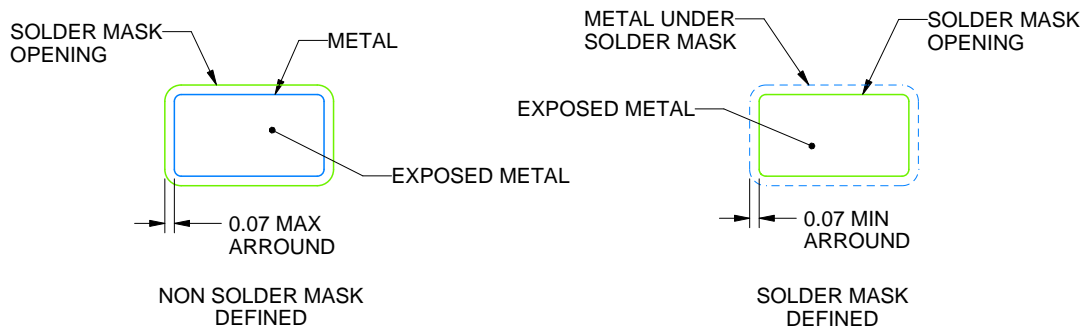

SOLDEMASK DETAILS

4214841/E 08/2024

NOTES: (continued)

- 4. Publication IPC-7351 may have alternate designs.
- 5. Solder mask tolerances between and around signal pads can vary based on board fabrication site.

# EXAMPLE STENCIL DESIGN

DDC0006A

SOT-23 - 1.1 max height

SMALL OUTLINE TRANSISTOR

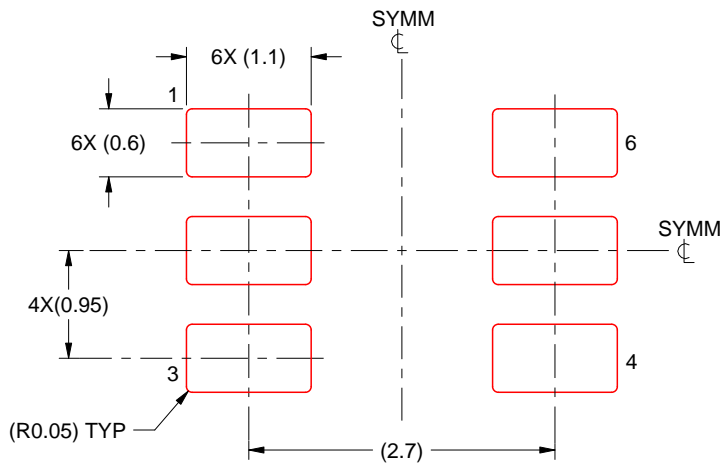

SOLDER PASTE EXAMPLE  
BASED ON 0.125 THICK STENCIL  
SCALE:15X

4214841/E 08/2024

NOTES: (continued)

6. Laser cutting apertures with trapezoidal walls and rounded corners may offer better paste release. IPC-7525 may have alternate design recommendations.
7. Board assembly site may have different recommendations for stencil design.

NGF0006A

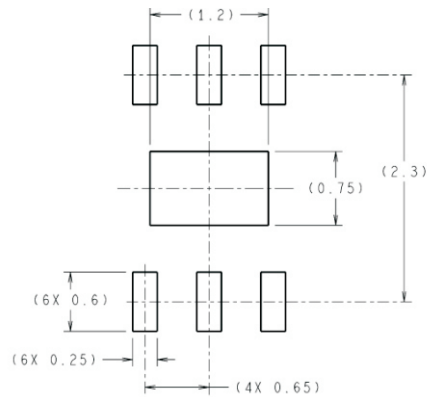

DIMENSIONS ARE IN MILLIMETERS  
DIMENSIONS IN ( ) FOR REFERENCE ONLY

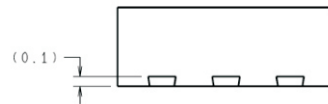

RECOMMENDED LAND PATTERN

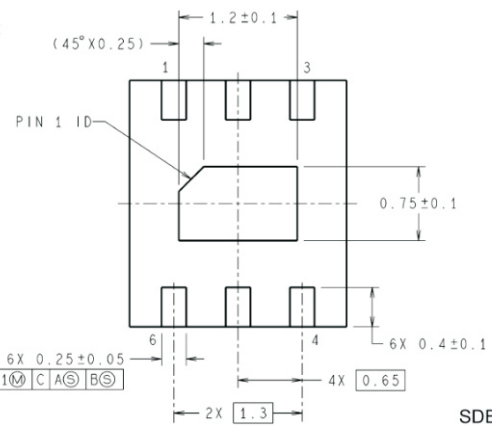
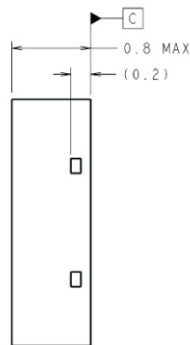
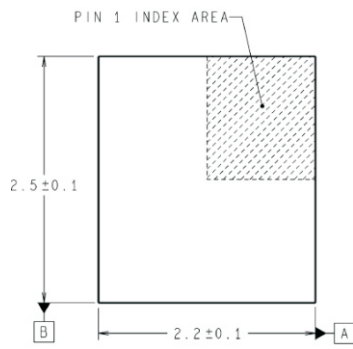

$\oplus 0.10$  C A B

SDB06A (Rev A)

# DGK0008A



# PACKAGE OUTLINE

VSSOP - 1.1 mm max height

SMALL OUTLINE PACKAGE



4214862/A 04/2023

**NOTES:**

PowerPAD is a trademark of Texas Instruments.

1. All linear dimensions are in millimeters. Any dimensions in parenthesis are for reference only. Dimensioning and tolerancing per ASME Y14.5M.
2. This drawing is subject to change without notice.
3. This dimension does not include mold flash, protrusions, or gate burrs. Mold flash, protrusions, or gate burrs shall not exceed 0.15 mm per side.
4. This dimension does not include interlead flash. Interlead flash shall not exceed 0.25 mm per side.
5. Reference JEDEC registration MO-187.



# EXAMPLE BOARD LAYOUT

DGK0008A

™ VSSOP - 1.1 mm max height

SMALL OUTLINE PACKAGE



LAND PATTERN EXAMPLE  
EXPOSED METAL SHOWN  
SCALE: 15X



SOLDER MASK DETAILS

4214862/A 04/2023

NOTES: (continued)

6. Publication IPC-7351 may have alternate designs.
7. Solder mask tolerances between and around signal pads can vary based on board fabrication site.
8. Vias are optional depending on application, refer to device data sheet. If any vias are implemented, refer to their locations shown on this view. It is recommended that vias under paste be filled, plugged or tented.
9. Size of metal pad may vary due to creepage requirement.

# EXAMPLE STENCIL DESIGN

DGK0008A

<sup>TM</sup> VSSOP - 1.1 mm max height

SMALL OUTLINE PACKAGE



SOLDER PASTE EXAMPLE  
SCALE: 15X

4214862/A 04/2023

NOTES: (continued)

11. Laser cutting apertures with trapezoidal walls and rounded corners may offer better paste release. IPC-7525 may have alternate design recommendations.
12. Board assembly site may have different recommendations for stencil design.

## IMPORTANT NOTICE AND DISCLAIMER

TI PROVIDES TECHNICAL AND RELIABILITY DATA (INCLUDING DATA SHEETS), DESIGN RESOURCES (INCLUDING REFERENCE DESIGNS), APPLICATION OR OTHER DESIGN ADVICE, WEB TOOLS, SAFETY INFORMATION, AND OTHER RESOURCES "AS IS" AND WITH ALL FAULTS, AND DISCLAIMS ALL WARRANTIES, EXPRESS AND IMPLIED, INCLUDING WITHOUT LIMITATION ANY IMPLIED WARRANTIES OF MERCHANTABILITY, FITNESS FOR A PARTICULAR PURPOSE OR NON-INFRINGEMENT OF THIRD PARTY INTELLECTUAL PROPERTY RIGHTS.

These resources are intended for skilled developers designing with TI products. You are solely responsible for (1) selecting the appropriate TI products for your application, (2) designing, validating and testing your application, and (3) ensuring your application meets applicable standards, and any other safety, security, regulatory or other requirements.

These resources are subject to change without notice. TI grants you permission to use these resources only for development of an application that uses the TI products described in the resource. Other reproduction and display of these resources is prohibited. No license is granted to any other TI intellectual property right or to any third party intellectual property right. TI disclaims responsibility for, and you will fully indemnify TI and its representatives against, any claims, damages, costs, losses, and liabilities arising out of your use of these resources.

TI's products are provided subject to [TI's Terms of Sale](#) or other applicable terms available either on [ti.com](https://www.ti.com) or provided in conjunction with such TI products. TI's provision of these resources does not expand or otherwise alter TI's applicable warranties or warranty disclaimers for TI products.

TI objects to and rejects any additional or different terms you may have proposed.

Mailing Address: Texas Instruments, Post Office Box 655303, Dallas, Texas 75265  
Copyright © 2024, Texas Instruments Incorporated