



16-Channel, Current-Input Analog-to-Digital Converter

FEATURES

- **SINGLE-CHIP SOLUTION TO MEASURE 16 LOW-LEVEL CURRENTS**
- **INTEGRATING I-TO-V CONVERSION FRONT-END**
- **PROGRAMMABLE FULL-SCALE : 3pC to 12pC**
- **ADJUSTABLE SPEED:**
 - Data Rate Up To 100kSPS
 - Integration Time Down To 10µs
- **ANALOG SUPPLY: +5V**
- **DIGITAL SUPPLY: +3.3V**

APPLICATIONS

- **CT SCANNER DAS**
- **PHOTODIODE SENSORS**
- **X-RAY DETECTION SYSTEMS**

Protected by US Patent #5841310

DESCRIPTION

The DDC316 is a 16-bit, 16-channel, current-input analog-to-digital converter (ADC). It combines both current-to-voltage and analog-to-digital (A/D) conversion so that 16 separate low-level current output devices (such as photodiodes) can be directly connected to its inputs and digitized.

For each of the 16 inputs, the DDC316 provides a dual-switched integrator front-end. This configuration allows for continuous current integration: while one integrator is being digitized by the on-chip ADC, the other is integrating the input current. Adjustable integration times range from 10µs to 1ms.

The DDC316 provides a serial interface of the output data, either multiplexed onto a single data output pin or parallel on four output pins. The output mode can be selected based on the available integration time.

The DDC316 uses a +5V analog supply and a +3.3V digital supply. Operating over the temperature range of 0°C to +70°C, the DDC316 is offered in a BGA-64 package.

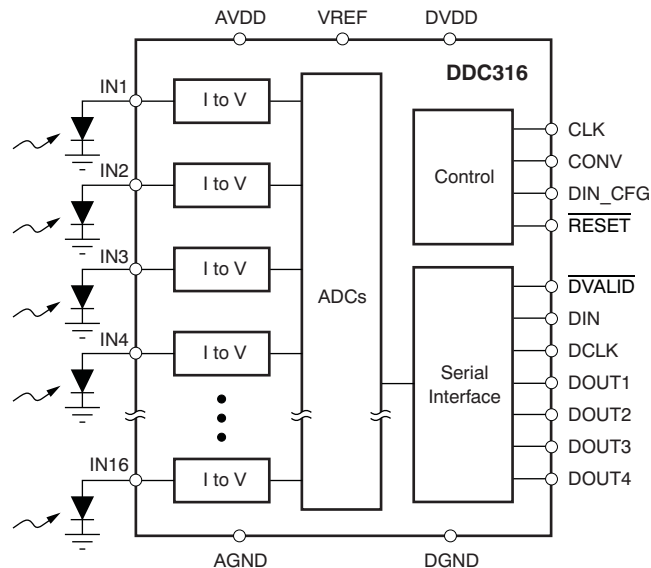

Please be aware that an important notice concerning availability, standard warranty, and use in critical applications of Texas Instruments semiconductor products and disclaimers thereto appears at the end of this data sheet.

All trademarks are the property of their respective owners.



This integrated circuit can be damaged by ESD. Texas Instruments recommends that all integrated circuits be handled with appropriate precautions. Failure to observe proper handling and installation procedures can cause damage.

ESD damage can range from subtle performance degradation to complete device failure. Precision integrated circuits may be more susceptible to damage because very small parametric changes could cause the device not to meet its published specifications.

PACKAGE/ORDERING INFORMATION

For the most current package and ordering information, see the Package Option Addendum at the end of this document, or see the TI web site at www.ti.com.

ABSOLUTE MAXIMUM RATINGS⁽¹⁾

AVDD to AGND	–0.3V to +6V
DVDD to DGND	–0.3V to +3.6V
AGND to DGND	±0.2V
VREF Input to AGND	2.0V to AVDD + 0.3V
Analog Input to AGND	–0.3V to +0.7V
Digital Input Voltage to DGND	–0.3V to DVDD + 0.3V
Digital Output Voltage to DGND	–0.3V to AVDD + 0.3V
Operating Temperature	0°C to +70°C
Storage Temperature	–60°C to +150°C
Junction Temperature (T _J)	+150°C

- (1) Stresses above these ratings may cause permanent damage. Exposure to absolute maximum conditions for extended periods may degrade device reliability. These are stress ratings only, and functional operation of the device at these or any other conditions beyond those specified is not implied.

ELECTRICAL CHARACTERISTICS

At $T_A = +25^\circ\text{C}$, $AV_{DD} = +5\text{V}$, $DV_{DD} = +3.3\text{V}$, $V_{REF} = +4.096\text{V}$, $t_{INT} = 20\mu\text{s}$, Range = 12pC, Format = 16 bits, CLK = 40MHz, and HI_SPEED Bit = 1, unless otherwise noted.

PARAMETER	TEST CONDITIONS	DDC316			UNIT
		MIN	TYP	MAX	
ANALOG INPUT RANGE					
Range 1		2.4	3	3.6	pC
Range 2		4.8	6	7.2	pC
Range 3		9.6	12	14.4	pC
Negative Full-Scale Range		–1.786% of Positive Full-Scale Range			pC
DYNAMIC CHARACTERISTICS					
Data Rate				100	kSPS
Integration Time, t_{INT}	HI_SPEED Bit = 1	20		1,000	μs
	HI_SPEED Bit = 0	10		20	μs
System Clock Input		1		40	MHz
Data Clock (DCLK)				40	MHz
	Daisy-Chain Readback			20	MHz
ACCURACY					
Resolution		12		16	Bits
Noise, Low-Level Input ⁽¹⁾	$C_{SENSOR}^{(2)} = 10\text{pF}$		3.5	6.0	LSB ⁽³⁾
Integral Linearity Error ⁽⁴⁾			8	16	LSB ⁽³⁾
Input Bias Current	$T_A = +25^\circ\text{C}$		± 2	± 10	pA
Range Error Match ⁽⁵⁾			0.2	1	% of FSR ⁽⁶⁾
Range Sensitivity to VREF	$V_{REF} = 4.096 \pm 0.1\text{V}$		1:1		
Offset Error			± 50	± 200	LSB ⁽³⁾
Offset Error Match ⁽⁵⁾			± 75	± 400	LSB ⁽³⁾
DC Bias Voltage ⁽⁷⁾	Low-Level Input (< 1% FSR)		± 2	± 10	mV
Power-Supply Rejection Ratio	at DC		40		LSB ⁽³⁾ /V
PERFORMANCE OVER TEMPERATURE					
Offset Drift			± 1		LSB/ $^\circ\text{C}$
Offset Drift Stability	Continuous Readings Over 1-Minute Intervals After a 10-Minute Warm-Up		<1		LSB
DC Bias Voltage Drift ⁽⁷⁾			± 10		$\mu\text{V}/^\circ\text{C}$
Input Bias Current Drift	Doubles Every $+10^\circ\text{C}$				
Range Drift ⁽⁸⁾			25		ppm/ $^\circ\text{C}$
Range Drift Match ⁽⁵⁾			± 10		ppm/ $^\circ\text{C}$
REFERENCE					
Voltage		4.000	4.096	4.200	V
DIGITAL INPUT/OUTPUT					
Logic Levels					
V_{IH}		0.8DVDD		DVDD + 0.1	V
V_{IL}		–0.1		0.2DVDD	V
V_{OH}	$I_{OH} = -100\mu\text{A}$	DVDD – 0.4			V
V_{OL}	$I_{OL} = 100\mu\text{A}$			0.4	V
Input Current (I_{IN})	$0 < V_{IN} < DV_{DD}$			± 10	μA
Data Format ⁽⁹⁾			Straight Binary		

(1) Input is less than 1% of full-scale.

(2) C_{SENSOR} is the capacitance seen at the DDC316 inputs from wiring, photodiode, etc.

(3) LSB refers to 16-bit resolution.

(4) A best-fit line is used in measuring nonlinearity.

(5) Matching between side A and side B of the same input.

(6) FSR is full-scale range.

(7) Voltage produced by the DDC316 at its input that is applied to the sensor.

(8) Range drift does not include external reference drift.

(9) Data format is Straight Binary with a small offset. The number of bits in the output word is controlled by the Format bit.

ELECTRICAL CHARACTERISTICS (continued)

At $T_A = +25^\circ\text{C}$, $AVDD = +5\text{V}$, $DVDD = +3.3\text{V}$, $VREF = +4.096\text{V}$, $t_{INT} = 20\mu\text{s}$, Range = 12pC, Format = 16 bits, CLK = 40MHz, and HI_SPEED Bit = 1, unless otherwise noted.

PARAMETER	TEST CONDITIONS	DDC316			UNIT
		MIN	TYP	MAX	
POWER-SUPPLY REQUIREMENTS					
Analog Power-Supply Voltage (AVDD)		4.75	5.0	5.25	V
Digital Power-Supply Voltage (DVDD)		3	3.3	3.6	V
Supply Current					
Analog Current					
Internal Reference Buffer	BUFDIS Bit = 0		95		mA
External Reference Buffer	BUFDIS Bit = 1		85		mA
Digital Current	DVDD = +3.3V		5		mA
Total Power Dissipation					
Internal Reference Buffer	BUFDIS Bit = 0, DVDD = +3.3V		540		mW
External Reference Buffer	BUFDIS Bit = 1, DVDD = +3.3V		440	640	mW
Per Channel Power Dissipation					
Internal Reference Buffer	BUFDIS Bit = 0, DVDD = +3.3V		31		mW/channel
External Reference Buffer	BUFDIS Bit = 1, DVDD = +3.3V		28	40	mW/channel

PIN CONFIGURATION

GXG AND ZXG PACKAGES BGA-64 (TOP VIEW)

Columns

H	G	F	E	D	C	B	A	
IN1 ○	IN3 ○	IN9 ○	IN12 ○	IN5 ○	IN7 ○	IN13 ○	IN15 ○	1
IN2 ○	IN4 ○	IN10 ○	IN11 ○	IN6 ○	IN8 ○	IN14 ○	IN16 ○	2
AGND ○	AGND ○	AGND ○	AGND ○	AGND ○	AGND ○	AGND ○	AGND ○	3
AVDD ○	AVDD ○	AVDD ○	AVDD ○	AVDD ○	AGND ○	VREF_IN ○	VREF ○	4
QGND ○	AGND ○	AGND ○	AGND ○	AGND ○	AGND ○	AGND ○	AGND ○	5
AVDD ○	AVDD ○	AVDD ○	AVDD ○	AGND ○	DGND ○	VREF ○	VREF ○	6
$\overline{\text{DVALID}}$ ○	DIN_CFG ○	DGND ○	DIN ○	AGND ○	DGND ○	DVDD ○	$\overline{\text{RESET}}$ ○	7
DOUT1 ○	DOUT2 ○	DOUT3 ○	DOUT4 ○	DCLK ○	CLK ○	DVDD ○	CONV ○	8

PIN DESCRIPTIONS

PIN	LOCATION	FUNCTION	DESCRIPTION
IN1–16	1A-1H, 2A-2H	Analog Input	Analog Inputs for Channels 1 to 16
AGND	3A-3H, 4C, 5A-5G, 6D, 7D	Analog	Analog Ground
VREF	4A, 6A, 6B	Analog Input	Voltage Reference for Internal Reference Buffer Mode
VREF_IN	4B	Analog Input	Voltage Reference for External Reference Buffer Mode
AVDD	4D-4H, 6E, 6F, 6G, 6H	Analog	Analog Power Supply, +5V Nominal
QGND	5H	Analog	Quiet Analog Ground
DGND	6C, 7C, 7F	Digital	Digital Ground
$\overline{\text{RESET}}$	7A	Digital Input	Digital Reset, Active Low
DVDD	7B, 8B	Digital	Digital Power Supply, +3V Nominal
DIN	7E	Digital Input	Serial Data Input for Daisy-Chain
DIN_CFG	7G	Digital Input	Configuration Register Data Input
$\overline{\text{DVALID}}$	7H	Digital Output	Data Valid Output, Active Low
CONV	8A	Digital Input	Conversion Control Input; 0 = Integrate on Side B, 1 = Integrate on Side A
CLK	8C	Digital Input	Master Clock Input
DCLK	8D	Digital Input	Serial Data Clock Input
DOUT4-1	8E-8H	Digital Output	Serial Data Output

TIMING DIAGRAMS

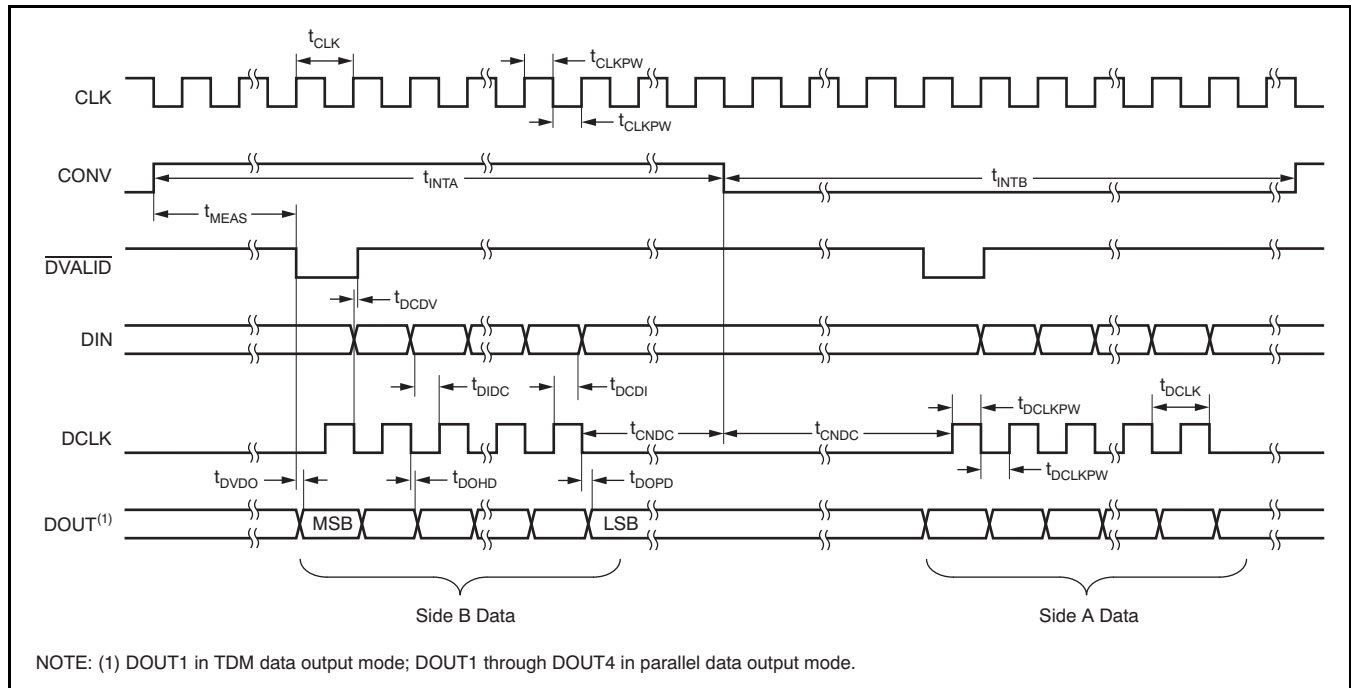

Figure 1. Serial Interface Timing

TIMING REQUIREMENTS FOR Figure 1

At $T_A = 0^{\circ}\text{C}$ to $+70^{\circ}\text{C}$ and $\text{DVDD} = 3\text{V}$ to 3.6V , unless otherwise noted.

SYMBOL	DESCRIPTION	MIN	TYP	MAX	UNIT
t_{CLK}	CLK period ($1/f_{\text{CLK}}$)	25		1000	ns
t_{CLKPW}	CLK pulse width, positive or negative	0.4			t_{CLK} periods
$t_{\text{INTA,B}}$	Integration time for sides A and B	HI_SPEED bit = 0		1000	t_{CLK} periods
		HI_SPEED bit = 0, CLK = 40MHz	10	25	μs
		HI_SPEED bit = 1	800	40,000	t_{CLK} periods
		HI_SPEED bit = 1, CLK = 40MHz	20	1000	μs
t_{MEAS}	Time required to perform measurement	HI_SPEED bit = 0	274		t_{CLK} periods
		HI_SPEED bit = 1	544		t_{CLK} periods
t_{DIDC}	Setup time from DIN to rising edge of DCLK	2			ns
t_{DCDI}	Hold time for DIN after rising edge of DCLK	0			ns
$t_{\text{DVDO}}^{(1)}$	Falling edge of DVALID to valid DOUT		6	10	ns
$t_{\text{DCDV}}^{(1)}$	Falling edge of first DCLK to rising edge of DVALID		19		ns
t_{DCLK}	DCLK period ($1/f_{\text{DCLK}}$)	25			ns
t_{DCLKPW}	DCLK pulse width, positive or negative	0.4			t_{DCLK} periods
$t_{\text{DOPD}}^{(1)}$	Propagation delay from the falling edge of DCLK to valid DOUT1			21	ns
$t_{\text{DOHD}}^{(1)}$	Hold time during which previous DOUT1 is valid after falling edge of DCLK	5			ns
t_{CNDC}	Time between CONV toggle and data retrieval	5			ns

(1) Output load = $100\text{k}\Omega \parallel 10\text{pF}$

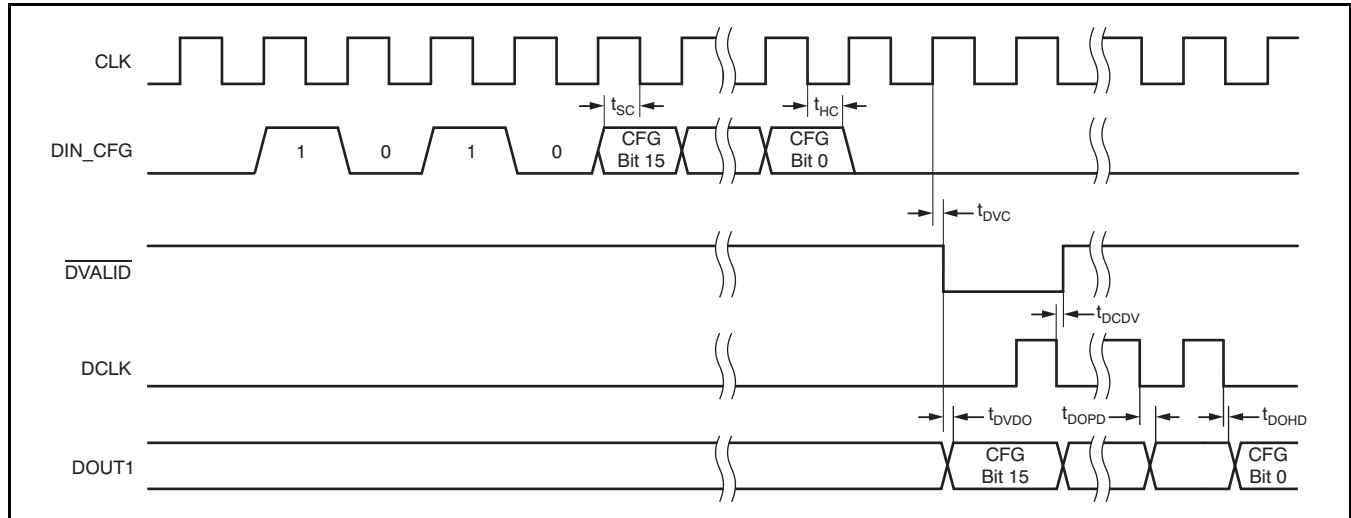
Figure 2. Configuration Register Read/Write Timing
TIMING REQUIREMENTS FOR Figure 2

 At $T_A = 0^\circ\text{C}$ to $+70^\circ\text{C}$ and $DVDD = 3.0\text{V}$ to 3.6V , unless otherwise noted.

SYMBOL	DESCRIPTION	MIN	TYP	MAX	UNIT
t_{sc}	Valid DIN_CFG to CLK falling edge; setup time	1	12		ns
t_{HC}	Valid DIN_CFG to CLK falling edge; hold time	3	12		ns
$t_{DVC}^{(1)}$	Delay of \overline{DVALID} from falling edge of CLK		18		ns
$t_{DCDV}^{(1)}$	Falling edge of first DCLK to rising edge of \overline{DVALID}		19		ns
$t_{DVDO}^{(1)}$	Delay from \overline{DVALID} falling edge to valid CFG bit 15 on DOUT1		6	10	ns
$t_{DOPD}^{(1)}$	Propagation delay from the falling edge of DCLK to valid DOUT1			21	ns
$t_{DOHD}^{(1)}$	Hold time during which previous DOUT1 is valid after falling edge of DCLK	5			ns

 (1) Output load = $100\text{k}\Omega \parallel 10\text{pF}$

TYPICAL CHARACTERISTICS

At $T_A = +25^\circ\text{C}$, unless otherwise indicated.

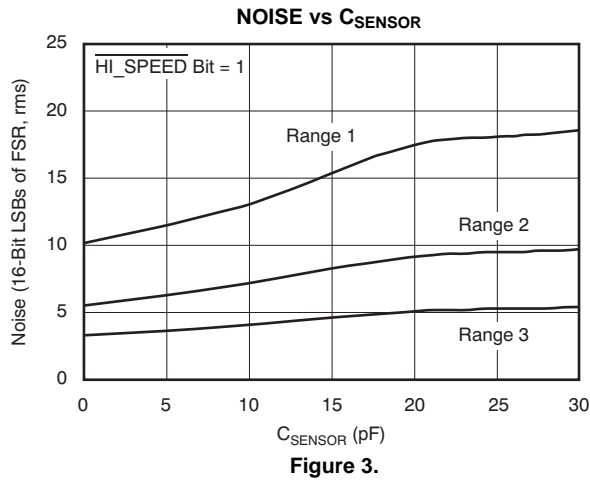

NOISE vs C_{SENSOR}

C_{SENSOR} (pF)	Noise (16-Bit LSBs of FSR, rms)		
	Range 1	Range 2	Range 3
0	10.2	5.6	3.3
10	13.1	7.2	4.1
20	17.5	9.2	5.1
30	18.6	9.7	5.4
50	22.3	11.6	6.4
100	34.3	17.8	9.4

NOTE: HI_SPEED bit = 1.

Figure 3.

THEORY OF OPERATION

GENERAL DESCRIPTION

The DDC316 contains 16 identical input channels that perform the function of current-to-voltage integration, followed by a multiplexed A/D conversion. Integration time is directly controlled via the CONV pin. Each input uses a dual-switched integrator so that the current-to-voltage integration can be continuous over

time. The 16 integrators from one side of the inputs are digitized, while the other 16 are integrating to achieve continuous charge collection. The results from the conversion are stored in a serial output shift register. The DVALID output goes low when the shift register contains valid data. A block diagram of the DDC316 is shown in Figure 4.

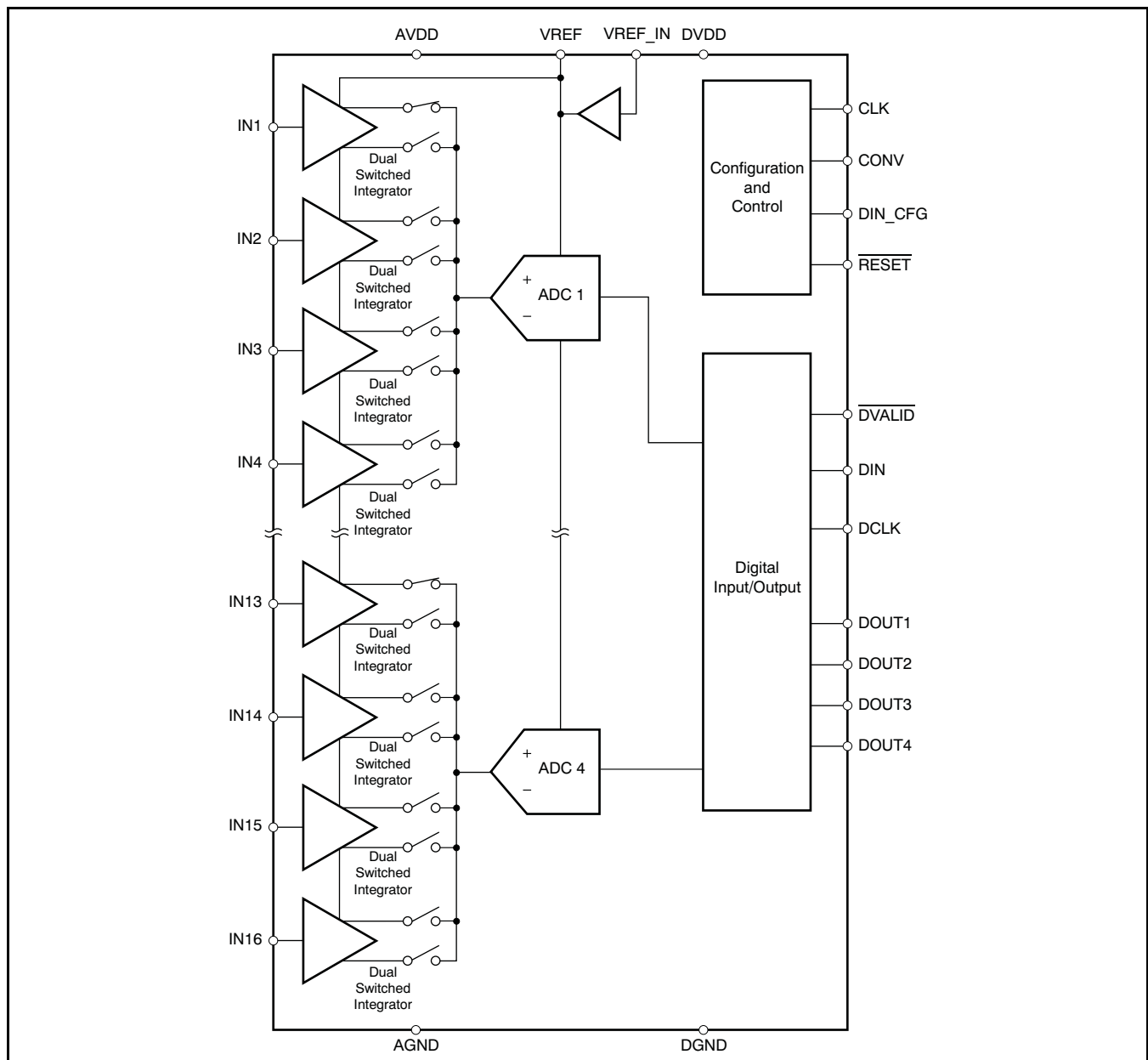

Figure 4. DDC316 Block Diagram

BASIC INTEGRATION CYCLE

The topology of the front-end of the DDC316 is an analog integrator, as shown in Figure 5. In this diagram, only input IN1 is shown. The input stage consists of an operational amplifier, a selectable feedback capacitor network (C_F), and several switches that implement the integration cycle.

The timing relationships of all of the switches shown in Figure 5 are illustrated in Figure 6. Note that Figure 6 conceptualizes the operation of the integrator input stage of the DDC316 and should not be used as an exact timing tool for design.

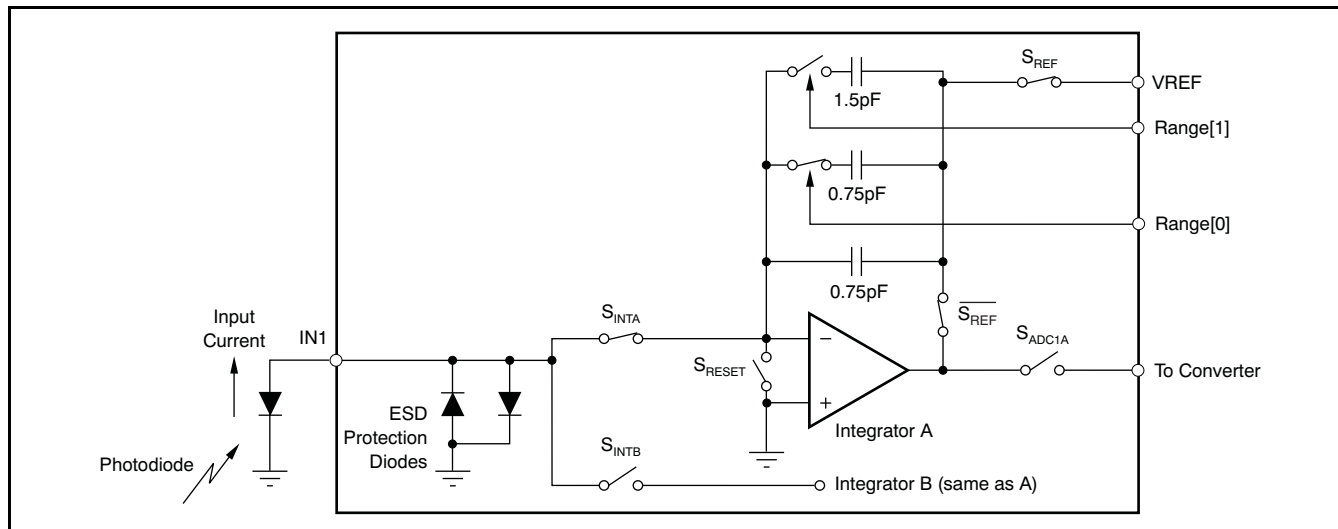

Figure 5. Basic Integration Configuration for Input 1

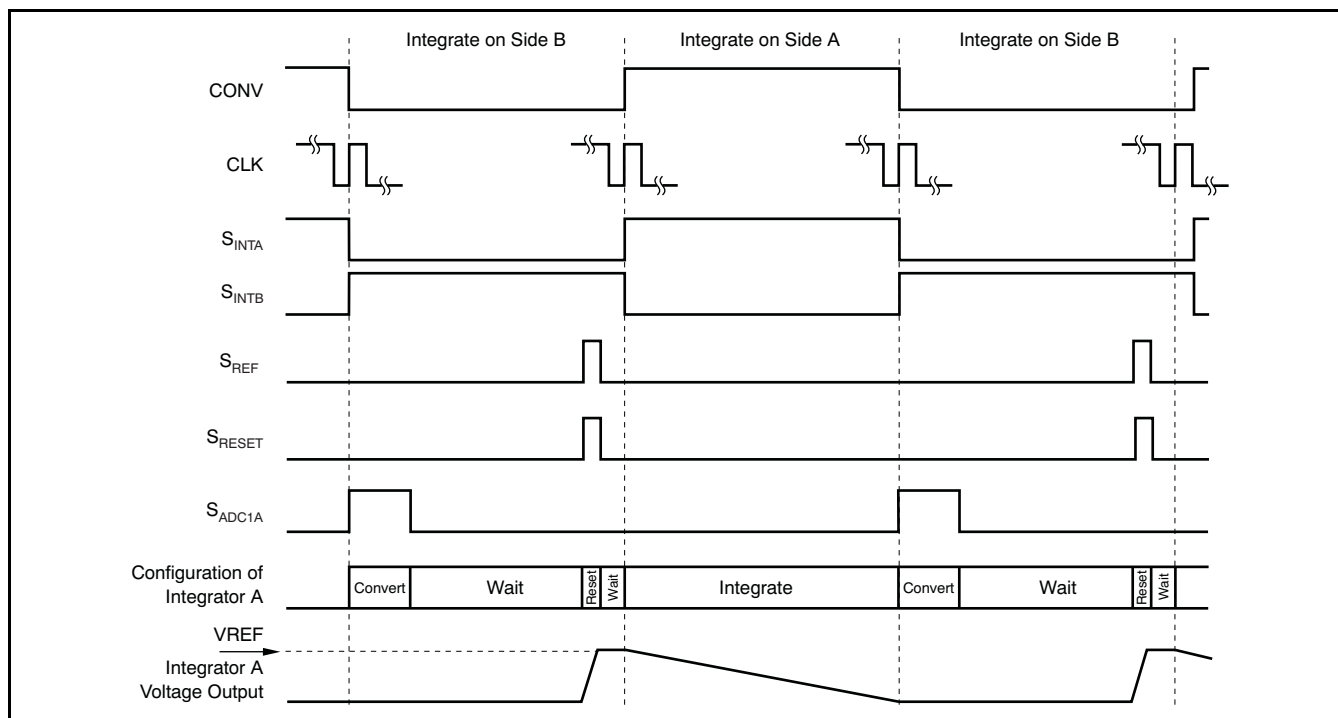

Figure 6. Conceptual Basic Integration Timing Diagram of Integrator A (as Illustrated in Figure 5)

Figure 7 shows the block diagrams of the five states of the front end integrator. The conversion starts with the integrator being configured as shown in Figure 7a. In this state, the ADC converts the integrated value of side A of the previous phase. Once the conversion is done, the integrator waits until the ADC finishes converting the other three integrated values (Figure 7b). At the completion of all four A/D conversions, the charge on the integrator capacitor (C_F) is reset with S_{REF} and S_{RESET} (see Figure 7c). In this manner, the selected capacitor is charged to the reference voltage, V_{REF} . Once the integration capacitor is charged, S_{REF} and S_{RESET} are switched so that V_{REF} is no longer connected to the amplifier circuit while it waits to begin integrating (see Figure 7d). With the rising edge of $CONV$, S_{INTA} closes, which begins the integration of side A. This process puts the integrator stage into Integrate mode (see Figure 7e).

Charge from the input signal is collected on the integration capacitor, causing the voltage output of the amplifier to decrease. The falling edge of $CONV$ stops the integration by switching the input signal from side A to side B (S_{INTA} and S_{INTB}). Before the falling edge of $CONV$, the signal on side B was converted by the ADC and reset during the time that side A was integrating. With the falling edge of $CONV$, side B starts integrating the input signal. At this point, the output voltage of the side A operational amplifier is presented to the input of the ADC, and the entire cycle repeats.

This internal switching network is controlled externally with the convert pin ($CONV$) and the system clock (CLK). For the best noise performance, $CONV$ must be synchronized with the rising edge of CLK . It is recommended that $CONV$ toggle within $\pm 5ns$ of the rising edge of CLK . The noninverting inputs of the integrators are connected to ground. Consequently, the DDC316 analog ground should be as clean as possible.

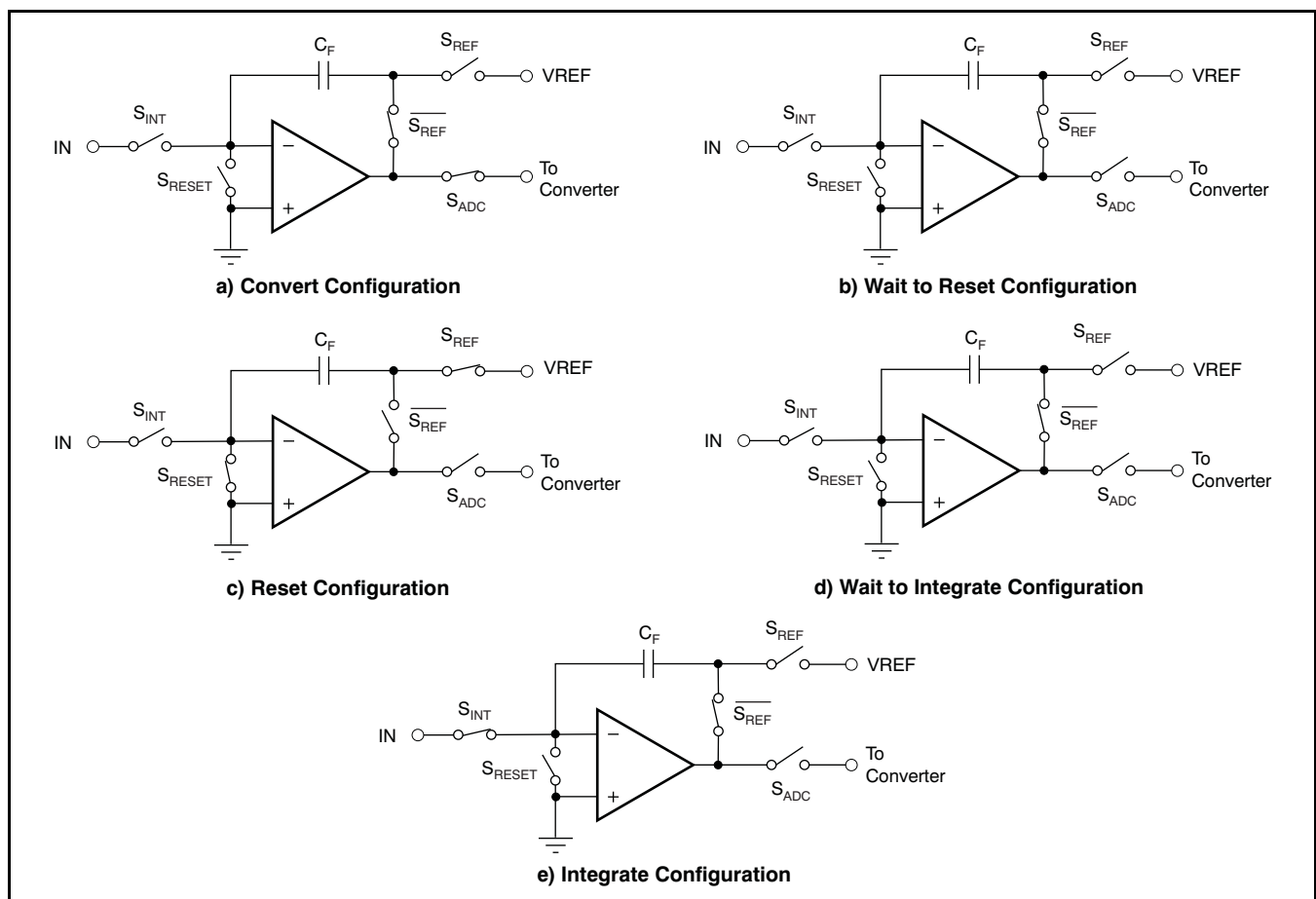

Figure 7. Diagrams for the Five Configurations of DDC316 Front-End Integrators

FREQUENCY RESPONSE

The frequency response of the DDC316 is set by the front-end integrators and is consistent with a traditional continuous time integrator, as shown in Figure 8. By adjusting t_{INT} , the user can change the 3dB bandwidth and the location of the notches in the response. The frequency response of the ADC that follows the front-end integrator is of no consequence because the converter samples a held signal from the integrators. That is, the input to the ADC is always a DC signal. Aliasing can occur because the output of the front-end integrators are sampled. Whenever the frequency of the input signal exceeds one-half of the sampling rate, the signal folds back down to lower frequencies.

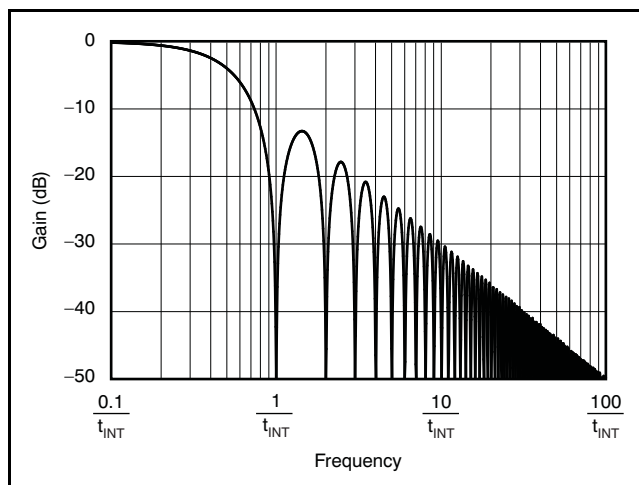

Figure 8. DDC316 Frequency Response

OPERATION SETTINGS

The DDC316 provides different settings of operation to provide flexibility in terms of range, resolution, etc. The settings are programmable using an on-chip register and are described in the following sections.

Ranges

There are three different capacitors available on-chip for both sides of every channel in the DDC316. The range control bits (Range[1:0]) change the capacitor value for all integrators. Consequently, all inputs and both sides of each input always have the same full-scale (FS) range. Table 1 shows the capacitor value selected for each range selection.

Table 1. Range Selection

RANGE	RANGE[1:0] BITS	C_F (pF, typ)	INPUT RANGE (pC, typ)
1	00	0.75	-0.0469 to 3
2	01	1.5	-0.0938 to 6
3	10	3	-0.1876 to 12

Resolution

The DDC316 provides three different resolutions for the convenience of the user. The user can select the resolution needed for the application and the time available for data retrieval. The three available resolutions are 16-bit, 14-bit, and 12-bit. The serial output data from the DDC316 are provided in an offset binary code, as shown in Table 2. The RES bits in the configuration register select how many bits are used in the output word. When 12-bits are selected, the last four bits are truncated; when 14-bits are chosen, the last two bits are truncated. Note that an offset is included in the output to allow slightly negative inputs (for example, from board leakages) from clipping the reading. The offset is approximately 1.8% of the positive full-scale.

Data Format

The DDC316 outputs 12 to 16 bits of data depending on the selected resolution. The format is straight binary with an offset to help prevent leakage currents from the printed circuit board (PCB), or the sensors forcing a clipping on the negative full-scale. Table 2 summarizes the ideal output codes for the different resolutions.

Table 2. Ideal Output Code⁽¹⁾ vs Input Signal

INPUT SIGNAL	IDEAL OUTPUT CODE RESOLUTION = 16 BITS	IDEAL OUTPUT CODE RESOLUTION = 14 BITS	IDEAL OUTPUT CODE RESOLUTION = 12 BITS
≥ 100% FS	1111 1111 1111 1111	1111 1111 1111 11	1111 1111 1111
0.07019% FS	0000 0100 1100 0000	0000 0100 1100 00	0000 0100 1100
0.02136% FS	0000 0100 1010 0000	0000 0100 1010 00	0000 0100 1010
0.00305% FS	0000 0100 1001 0100	0000 0100 1001 01	0000 0100 1001
0.001525% FS	0000 0100 1001 0011	0000 0100 1001 00	0000 0100 1001
0% FS	0000 0100 1001 0010	0000 0100 1001 00	0000 0100 1001
-1.7857% FS	0000 0000 0000 0000	0000 0000 0000 00	0000 0000 0000

(1) Excludes the effects of noise, INL, offset, and gain errors.

Data Output Modes

The DDC316 provides two data output modes: time division multiplexed (TDM) and parallel. In TDM mode, data from all 16 channels are output on a single data output line, DOUT1, as shown in Figure 9. In this mode, DOUT2 through DOUT4 are not used and forced to logic low.

In parallel output mode, as shown in Figure 10, four channels of data are output on the four DOUT lines, DOUT1 through DOUT4.

In either mode, the most significant bit (MSB) is shifted out first.

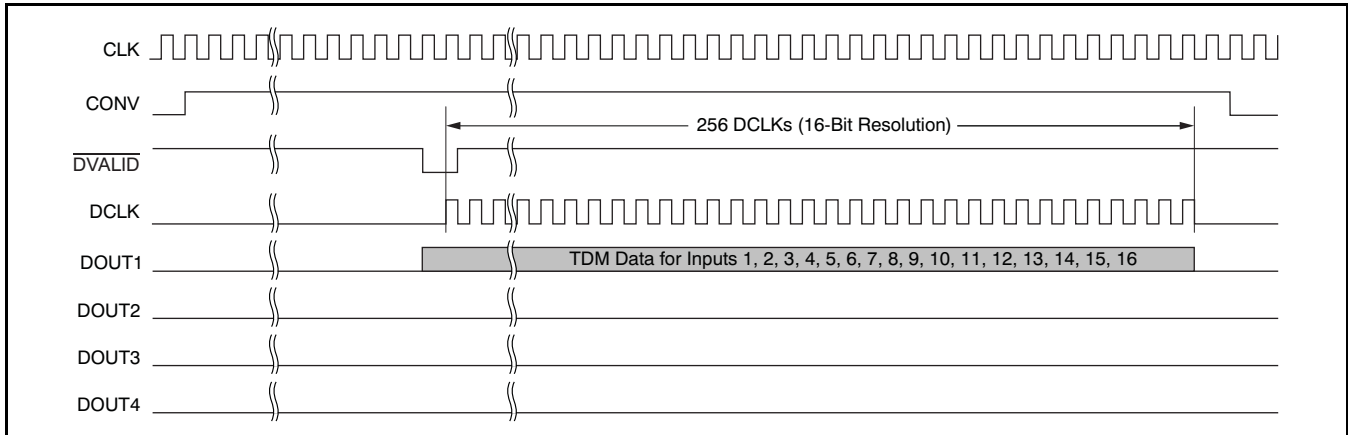

Figure 9. TDM Data Output

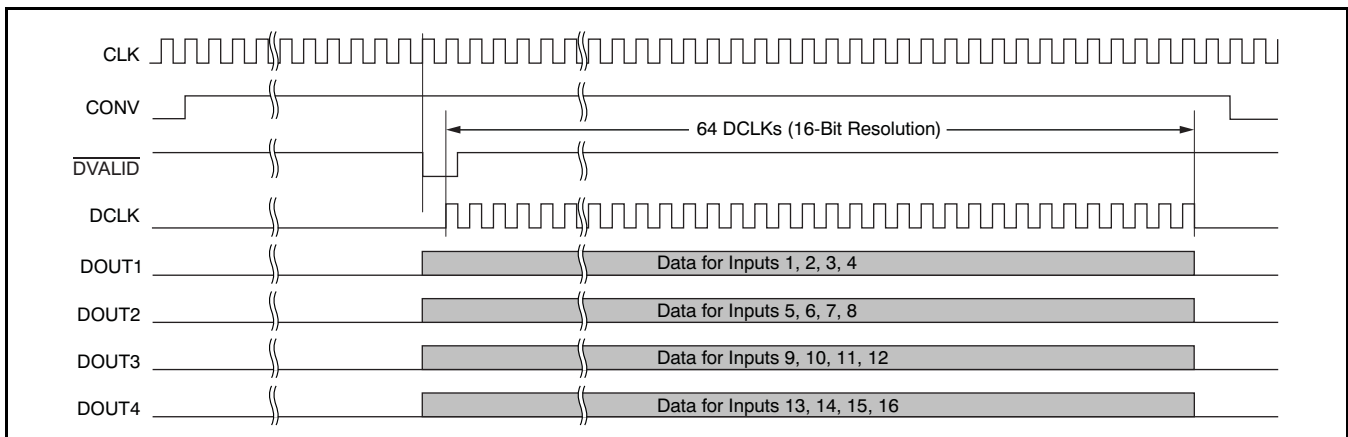

Figure 10. Parallel Data Output

MINIMUM INTEGRATION TIME

The minimum integration time of the DDC316 is set by the master clock (CLK) and the `HI_SPEED` bit, as shown in Table 3. The integration time specification must always be met for both side A and side B integrations (t_{INTA} and t_{INTB}). Failure to meet integration time specifications gives invalid conversion results.

Table 3. Minimum Integration Times

HI_SPEED BIT	VALID RESOLUTIONS	MINIMUM INTEGRATION TIME (MINIMUM t_{INT})	
0	12-bit only	400 t_{CLK} periods	10 μ s (for CLK = 40MHz)
1	12-bit to 16-bit	800 t_{CLK} periods	20 μ s (for CLK = 40MHz)

When operating with the `HI_SPEED` bit set to 0, the DDC316 operates internally at a higher speed and the performance is reduced to fundamentally 12 bits. It is recommended, therefore, that the `RES[1:0]` bits should be set to 12-bit resolution when `HI_SPEED` = 0. This will provide more flexibility in retrieving data, because the time required to read back the conversion results is shorter.

DATA RETRIEVAL TIME

The available time for retrieving the conversion data (t_{RETRV}) from the DDC316 is the difference between the integration time (t_{INT}) and the measurement time (t_{MEAS}), as shown in Figure 11. Retrieval begins after `DVALID` goes low, and must complete before `CONV` toggles, for optimal noise performance (see the t_{CNDC} timing specification).

Sometimes, it is not possible to retrieve all of the data in time when using the TDM data output mode; for example, when integration times are short and `DCLK` is slow. In these cases, using the parallel data output mode will help because the required time for retrieval decreases by a factor of four.

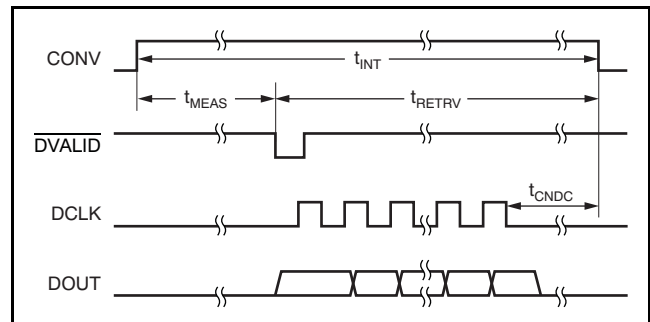

Figure 11. Data Retrieval Time

CONFIGURATION REGISTER

The DDC316 configuration shown in [Table 4](#) is controlled by and configured with an on-chip, 16-bit configuration register.

Table 4. Configuration Register

Bit 15	Bit 14	Bit 13	Bit 12	Bit 11	Bit 10	Bit 9	Bit 8
1	MODE	RES[1]	RES[0]	RANGE[1]	RANGE[0]	0	HI_SPEED
Bit 7	Bit 6	Bit 5	Bit 4	Bit 3	Bit 2	Bit 1	Bit 0
TM[1]	TM[0]	0	BUFDIS	0	0	0	0

The following section gives a brief description of the programmable bits and the method to program the bits. Note that in the event of an external reset or a power-on reset, all the configuration bits are set to default values. The bits need to be reprogrammed as needed after a reset.

Bit Descriptions

- Bit 15** Unused bit. This bit must always be set to one. During a power-up or reset event, this bit is set to zero and must be programmed to one.
- Bit 14** **MODE**—Data Output Mode. This bit selects between the parallel and serial data output (time division multiplexing, or TDM) modes, as shown in [Table 5](#).

Table 5. Data Output Mode

MODE	DATA OUTPUT MODE
0	Parallel, using DOUT1, DOUT2, DOUT3, and DOUT4 (default)
1	Serial, time division multiplexed (TDM) on DOUT1

- Bits 13-12** **RES[1:0]**—Output Data resolution. These bits set the output data resolution. The value of the output resolution is the same for RES[1:0] = '10' and RES[1:0] = '11'.

Table 6. Output Data Resolution

RES[1:0]	OUTPUT RESOLUTION
00	16 Bits (default)
01	14 Bits
10	12 Bits
11	

- Bits 11-10** **RANGE[1:0]**—Full-Scale Input Range. These range bits set the value of the integration capacitors that are used in the dual-switched integrators. [Table 7](#) shows the three different capacitor values available. The value of the maximum input charge is the same for RANGE = '10' and RANGE = '11'.

Table 7. Full-Scale Range

RANGE[1:0]	MAXIMUM INPUT CHARGE
00	3pC (default)
01	6pC
10	12pC
11	

Bit 9 Unused bit. This bit is reset to zero and must always be set to zero.

Bit 8 **HI_SPEED**—High-Speed Operation Selection.

This bit sets which speed (normal or high) will be used. The default is normal speed, and is the generally recommended operating condition. However, if shorter integration times are needed than are supported during normal operation, then high-speed mode is available. Note that performance reduces to the 12-bit level during high-speed mode.

Table 8. High-Speed Mode Selection

HI_SPEED	SPEED
0	High speed
1	Normal speed (default)

Bits 7-6 **TM[1:0]**—Test Mode Selection.

Test mode (TM) bits allow for configuration of the device to operate in either normal mode or test modes for verification purposes, as shown in [Table 9](#). The test modes are provided as a means of evaluating the DDC316 noise.

In test mode 1, the inputs (IN1 through IN16) are disconnected from the DDC316 integrators to enable the user to measure a zero input signal, regardless of the current supplied to the DDC316 by the external sensor.

In test mode 2, the inputs (IN1 through IN16) are disconnected from the DDC316 integrators and at the same time a 10pF capacitor is added to the input to emulate the sensor capacitance.

In test mode 3, the inputs are disconnected from the DDC316 integrators. Each time a new conversion begins (CONV toggles), a fixed amount of charge (approximately 1.5pC) is dumped into the integrator.

Table 9. Test Mode Decoding

TM[1:0]	TEST MODE FUNCTION
00	Normal mode (default)
01	Test mode 1 (inputs opened)
10	Test mode 2 (inputs opened and 10pF internal capacitor connected to integrators)
11	Test mode 3 (inputs opened and 1.5pC charge dumped into the integrators during each conversion)

Bit 5 Unused bit. This bit is reset to zero and must always be set to zero.

Bit 4 **BUFDIS**—Internal Reference Buffer Disable.

This bit is used to turn the internal reference buffer off, as shown in [Table 10](#). See the [Voltage Reference](#) section for more details.

Table 10. Internal Reference Buffer Disable

BUFDIS	INTERNAL REFERENCE BUFFER STATUS
0	Internal buffer enabled
1	Internal buffer disabled (default)

Bits 3-0 Unused bits. These bits are reset to zero and must always be set to zero.

Writing and Reading of the Configuration Register

Figure 2 shows the timing diagram for writing to and reading from the configuration register. Writing and reading must be done before or after CONV toggles. The data on pin DIN_CFG are latched on the falling edge of CLK. The first four bits are used as preamble; only when these bits equal '1010' are the contents of the following 16 bits loaded into the configuration register. Once the content is loaded, the shift register immediately clears so that a new configuration can be written, if needed. It is recommended to leave the DIN_CFG pin to logic '0' when not programming the register.

Once the configuration register updates, it is loaded into the data shift register to be output on DOUT1. When DVALID is goes low, the configuration register is available to be read. If the data are not read back, then the register is overwritten by the conversion data on the following conversion. Data are shifted out on the falling edge of DCLK.

SYSTEM AND DATA CLOCKS (CLK AND DCLK)

The system clock is supplied to CLK and the data clock is supplied to DCLK. Make sure the clock signals are clean; avoid overshoot or ringing. DCLK should be held low after the data have been shifted out, or while CONV is transitioning; DCLK should not be left free-running.

The integration and conversion process is fundamentally independent of the data retrieval process. Consequently, the CLK and DCLK frequencies need not be the same, although for best performance, it is highly recommended that they be derived from the same clocking source to keep their phase relationship constant.

When using multiple DDC316s, pay close attention to the DCLK distribution on the printed circuit board (PCB). In particular, make sure to minimize skew in the DCLK signal because the skew can lead to timing violations in the serial interface specifications.

DATA VALID ($\overline{\text{DVALID}}$)

The $\overline{\text{DVALID}}$ signal indicates that data are ready. Data retrieval may begin after $\overline{\text{DVALID}}$ goes low. This signal goes low on the rising edge of the system clock (CLK), and goes high on the first falling edge of DCLK during the data retrieval process. Data retrieval from the DDC316 can be done either by polling the $\overline{\text{DVALID}}$ signal or by counting the number of clock cycles after a transition of the CONV signal. While using the counting method, the number of clock cycles to wait depends on the mode of operation, either the low power or the high speed mode. The exact number of CLK cycles to wait for the two different modes is given in Table 3.

READEBACK WITH MULTIPLE DDC316s

The serial interface supports daisy-chaining to simplify connections when using multiple DDC316s together. Figure 12 shows an example of a 64-channel system. The DIN pin is used to shift data into the DDC316s. Additional DCLK pulses must then be given during readback to ensure all the data have shifted through, as shown in Figure 13.

Note that daisy-chaining is only supported in TDM output mode, and will not work when using parallel data output mode. When the daisy-chaining function is not used, connect DIN to digital ground.

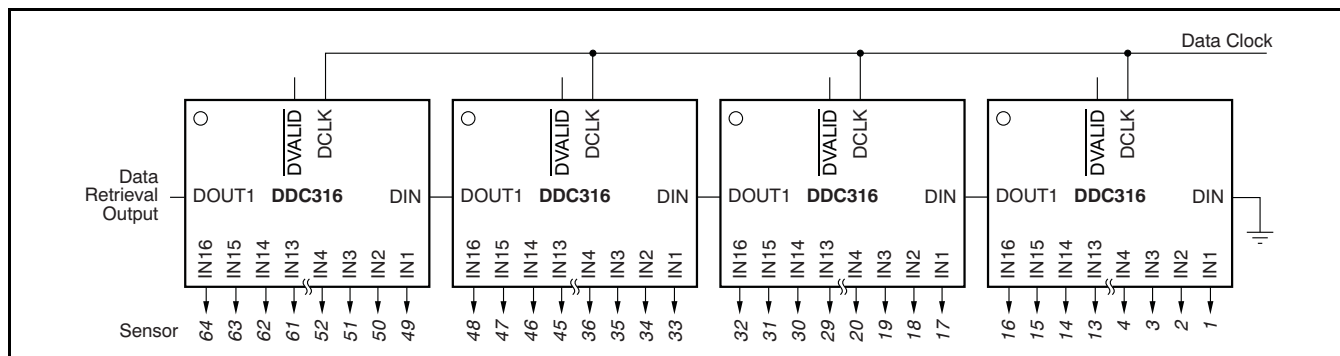

Figure 12. Daisy-Chain Configuration of a 64-Channel System

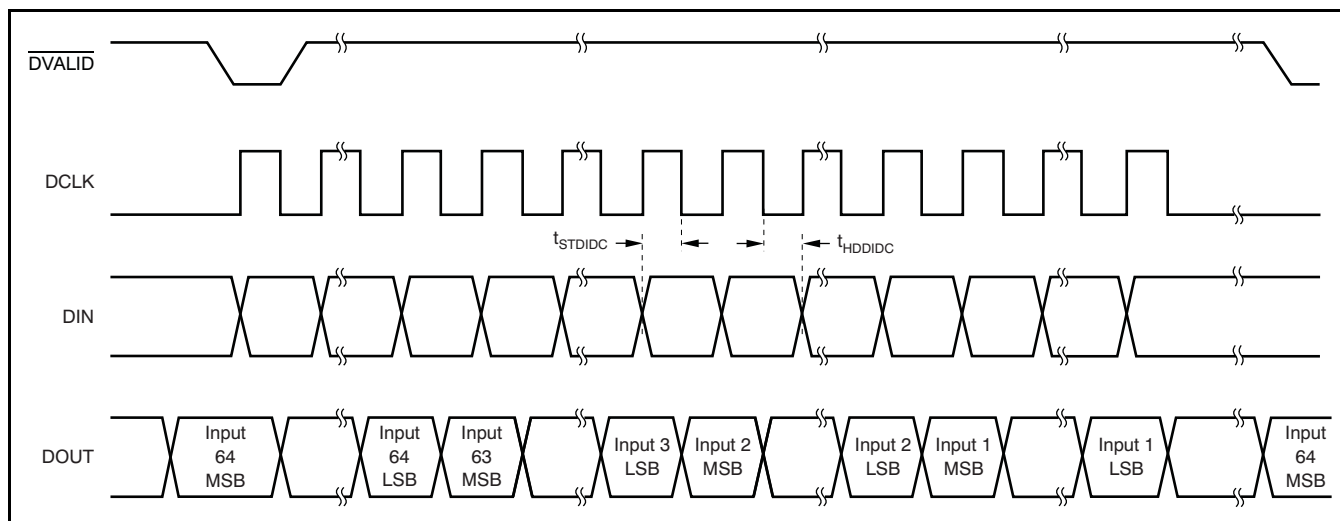

Figure 13. Daisy-Chain Readback of Four Devices (64 Channels)

VOLTAGE REFERENCE

The reference voltage is used to reset the integration capacitors before an integration cycle begins. It is also used by the ADCs when they measure the voltage stored on the integrators after an integration cycle ends. During this sampling, the external reference must supply the charge needed by the ADCs. For an integration time of $20\mu\text{s}$, this charge translates to an average VREF current of approximately $270\mu\text{A}$. The amount of charge needed by the ADC is independent of the integration time; therefore, increasing the integration time lowers the average current. For example, an integration time of $40\mu\text{s}$ lowers the average VREF current to $135\mu\text{A}$.

It is critical that VREF be stable during the different modes of operation (see [Figure 7](#)). The ADC measures the voltage on the integrator with respect to VREF. Since the integrator capacitors are initially reset to VREF, any drop in VREF, from the time the capacitors are reset to the time when the converter measures the integrator output, introduces an offset. It is also important that VREF be stable over longer periods of time because changes in VREF correspond directly to changes in the full-scale range. Finally, VREF should introduce as little additional noise as possible. For these reasons, it is strongly recommended that the external reference source be buffered with an operational amplifier.

The DDC316 offers two options for driving the reference voltage: through an external buffer or through an internal buffer. In both the cases, the reference voltage is generated external to the chip using an accurate reference, such as the [REF3140](#).

Internal VREF Buffer

The DDC316 provides an internal VREF buffer to drive the four on-chip ADCs. The reference voltage must be provided at VREF_IN (pin 4B), as shown in [Figure 14](#). The external capacitors at the VREF pins are necessary to stabilize the internal buffer. It is recommended that these capacitors be placed as close as possible to the device under test. Also, good

quality capacitors with low ESR ($< 1\Omega$) are necessary for optimum performance. High ESR capacitors will lead to oscillation of the internal buffer. Ceramic capacitors with ESR $< 1\Omega$ at 100kHz are recommended.

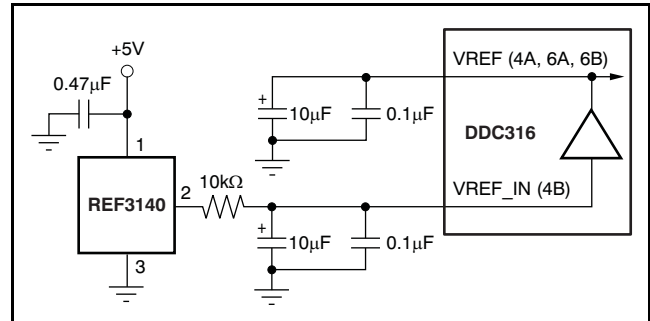

Figure 14. Recommended Circuit when Using the Internal VREF Buffer

External VREF Buffer

The internal buffer can be turned off using the control bits as explained in the [Configuring the Modes](#) section under Bit 4 and [Table 10](#). For this option, configure the driving circuit as illustrated in [Figure 15](#). The voltage reference is generated by a $+4.096\text{V}$ reference. A low-pass filter to reduce noise connects the reference to an operational amplifier configured as a buffer. The VREF_IN pin must be left disconnected.

This amplifier used as buffer should have low noise and input/output common-mode ranges that support VREF. Even though the circuit in [Figure 15](#) might appear to be unstable as a result of the large output capacitors, it works well for most operational amplifiers. It is **not** recommended that series resistance be placed in the output lead to improve stability because it can cause a drop in VREF and produce large offsets.

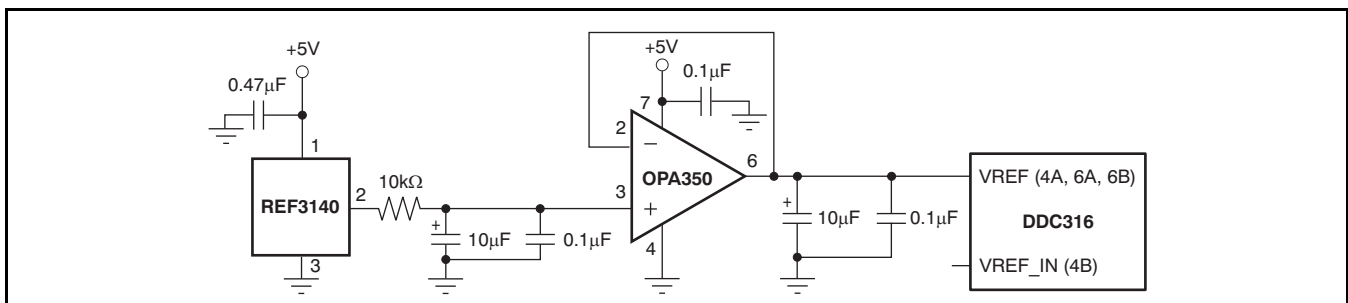

Figure 15. Recommended Circuit when Using an External VREF Buffer

RESET ($\overline{\text{RESET}}$)

The DDC316 can be reset asynchronously by taking the $\overline{\text{RESET}}$ input low. Make sure the reset pulse is at least two CLK cycles wide. Once the $\overline{\text{RESET}}$ signal is pulled high, the internal reset is released t_{RST} later, after which the configuration register can be written. It is very important that $\overline{\text{RESET}}$ is glitch-free to avoid unintentional resets.

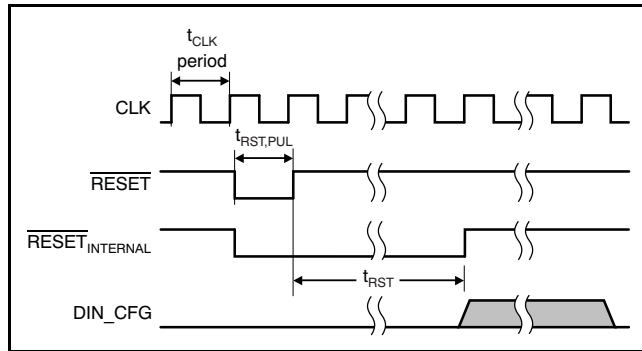

Figure 16. Reset Timing

POWER-UP SEQUENCING

Figure 17 shows the internal timing after the part powers up. Once the digital supply is above the threshold voltage, the internal power-on reset circuit releases the POR signal. The internal reset signal to the digital logic is released t_{POR} time after the $\text{POR}_{\text{INTERNAL}}$, after which the configuration register can be written.

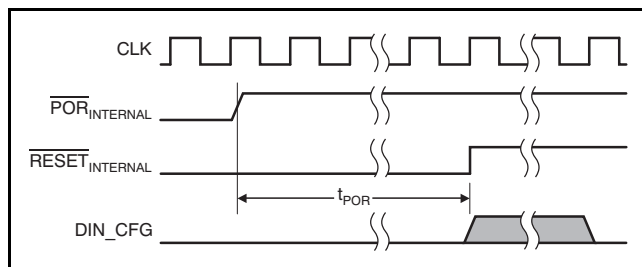

Figure 17. Power-Up Timing

Table 11. Timing Figure 16 and Figure 17

SYMBOL	DESCRIPTION	MIN	TYP	MAX	UNITS
$t_{\text{RST,PUL}}$	$\overline{\text{RESET}}$ pin low width	2			t_{CLK} periods
t_{RST}	Wait from $\overline{\text{RESET}}$ high to beginning of configuration register write	20			t_{CLK} periods
t_{POR}	Wait from power-up to power-on reset release	40,000			t_{CLK} periods

LAYOUT

Power Supplies and Grounding

Both AVDD and DVDD should be as quiet as possible. It is particularly important to eliminate noise from AVDD that is nonsynchronous with the DDC316 operation. For this reason, switching-supplies are not recommended. Figure 18 illustrates how to supply power to the DDC316. Each supply of the DDC316 should be bypassed with 10 μF solid ceramic capacitors. It is recommended that both the analog and digital grounds (AGND and DGND) be connected to a single ground plane on the PCB.

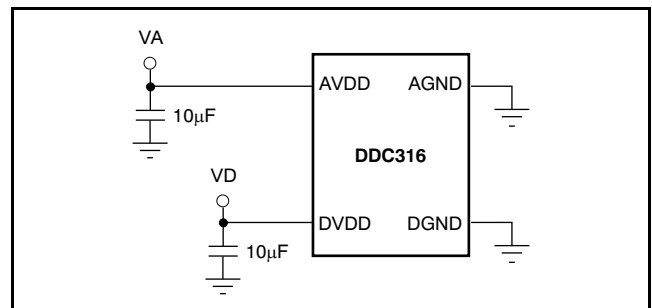

Figure 18. Power-Supply Connections

Shielding Analog Signal Paths

As with any precision circuit, careful PCB layout ensures the best performance. It is essential to make short, direct interconnections and avoid stray wiring capacitance, particularly at the analog input pins and QGND. These analog input pins are high-impedance and extremely sensitive to extraneous noise. The QGND pin should be treated as a sensitive analog signal and connected directly to the supply ground with proper shielding. Leakage currents between the PCB traces can exceed the input bias current of the DDC316 if shielding is not implemented. Digital signals should be kept as far as possible from the analog input signals on the PCB.

Revision History

NOTE: Page numbers for previous revisions may be differ from page numbers in the current version.

Changes from Original (March 2008) to Revision A	Page
• Changed test condition for Offset Drift Stability specification	3
• Changed Figure 1	6
• Changed Figure 2	7
• Added missing text.....	9
• Deleted duplicate mechanical package drawing.....	20

PACKAGING INFORMATION

Orderable Device	Status (1)	Package Type	Package Drawing	Pins	Package Qty	Eco Plan (2)	Lead finish/ Ball material (6)	MSL Peak Temp (3)	Op Temp (°C)	Device Marking (4/5)	Samples
DDC316CGXGR	ACTIVE	NFBGA	GXG	64	1000	Non-RoHS & Non-Green	SN/PB	Level-3-240C-168 HR	0 to 70	DDC316	Samples
DDC316CGXGT	ACTIVE	NFBGA	GXG	64	250	Non-RoHS & Non-Green	SN/PB	Level-3-240C-168 HR	0 to 70	DDC316	Samples
DDC316CZXGR	ACTIVE	NFBGA	ZXG	64	1000	RoHS & Green	SNAGCU	Level-3-260C-168 HR	0 to 70	DDC316	Samples

(1) The marketing status values are defined as follows:

ACTIVE: Product device recommended for new designs.

LIFEBUY: TI has announced that the device will be discontinued, and a lifetime-buy period is in effect.

NRND: Not recommended for new designs. Device is in production to support existing customers, but TI does not recommend using this part in a new design.

PREVIEW: Device has been announced but is not in production. Samples may or may not be available.

OBSELETE: TI has discontinued the production of the device.

(2) **RoHS:** TI defines "RoHS" to mean semiconductor products that are compliant with the current EU RoHS requirements for all 10 RoHS substances, including the requirement that RoHS substance do not exceed 0.1% by weight in homogeneous materials. Where designed to be soldered at high temperatures, "RoHS" products are suitable for use in specified lead-free processes. TI may reference these types of products as "Pb-Free".

RoHS Exempt: TI defines "RoHS Exempt" to mean products that contain lead but are compliant with EU RoHS pursuant to a specific EU RoHS exemption.

Green: TI defines "Green" to mean the content of Chlorine (Cl) and Bromine (Br) based flame retardants meet JS709B low halogen requirements of <=1000ppm threshold. Antimony trioxide based flame retardants must also meet the <=1000ppm threshold requirement.

(3) MSL, Peak Temp. - The Moisture Sensitivity Level rating according to the JEDEC industry standard classifications, and peak solder temperature.

(4) There may be additional marking, which relates to the logo, the lot trace code information, or the environmental category on the device.

(5) Multiple Device Markings will be inside parentheses. Only one Device Marking contained in parentheses and separated by a "-" will appear on a device. If a line is indented then it is a continuation of the previous line and the two combined represent the entire Device Marking for that device.

(6) Lead finish/Ball material - Orderable Devices may have multiple material finish options. Finish options are separated by a vertical ruled line. Lead finish/Ball material values may wrap to two lines if the finish value exceeds the maximum column width.

Important Information and Disclaimer:The information provided on this page represents TI's knowledge and belief as of the date that it is provided. TI bases its knowledge and belief on information provided by third parties, and makes no representation or warranty as to the accuracy of such information. Efforts are underway to better integrate information from third parties. TI has taken and continues to take reasonable steps to provide representative and accurate information but may not have conducted destructive testing or chemical analysis on incoming materials and chemicals. TI and TI suppliers consider certain information to be proprietary, and thus CAS numbers and other limited information may not be available for release.

In no event shall TI's liability arising out of such information exceed the total purchase price of the TI part(s) at issue in this document sold by TI to Customer on an annual basis.

TAPE AND REEL INFORMATION

QUADRANT ASSIGNMENTS FOR PIN 1 ORIENTATION IN TAPE



*All dimensions are nominal

Device	Package Type	Package Drawing	Pins	SPQ	Reel Diameter (mm)	Reel Width W1 (mm)	A0 (mm)	B0 (mm)	K0 (mm)	P1 (mm)	W (mm)	Pin1 Quadrant
DDC316CGXGR	NFBGA	GXG	64	1000	330.0	16.4	8.3	8.3	2.25	12.0	16.0	Q1
DDC316CZXGR	NFBGA	ZXG	64	1000	330.0	16.4	8.3	8.3	2.25	12.0	16.0	Q1

TAPE AND REEL BOX DIMENSIONS

*All dimensions are nominal

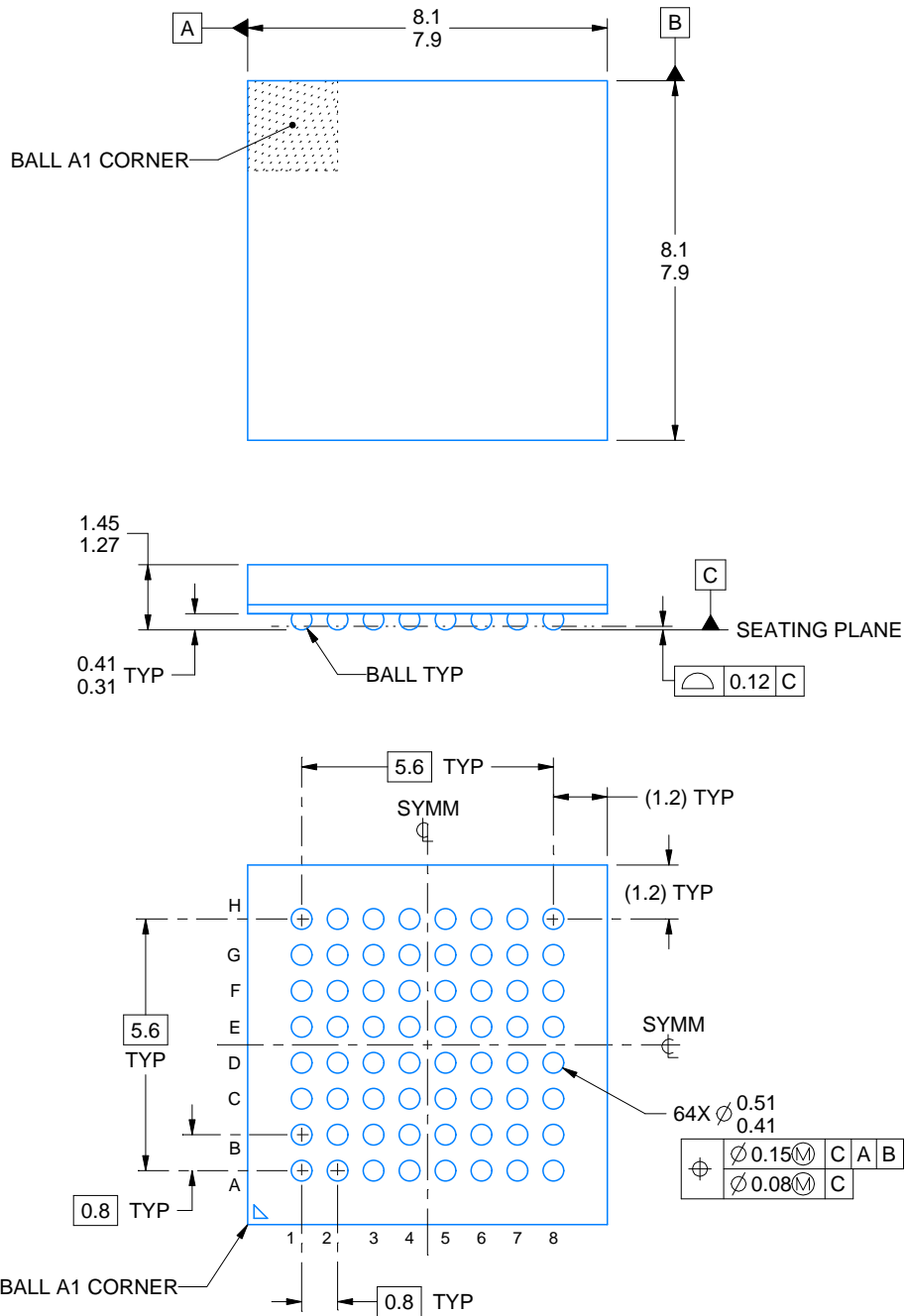
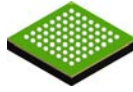
Device	Package Type	Package Drawing	Pins	SPQ	Length (mm)	Width (mm)	Height (mm)
DDC316CGXGR	NFBGA	GXG	64	1000	350.0	350.0	43.0
DDC316CZXGR	NFBGA	ZXG	64	1000	350.0	350.0	43.0



4220524/A 12/2018

NOTES:

1. All linear dimensions are in millimeters. Any dimensions in parenthesis are for reference only. Dimensioning and tolerancing per ASME Y14.5M.
2. This drawing is subject to change without notice.

EXAMPLE BOARD LAYOUT

GXG0064A

NFBGA - 1.45 mm max height

PLASTIC BALL GRID ARRAY

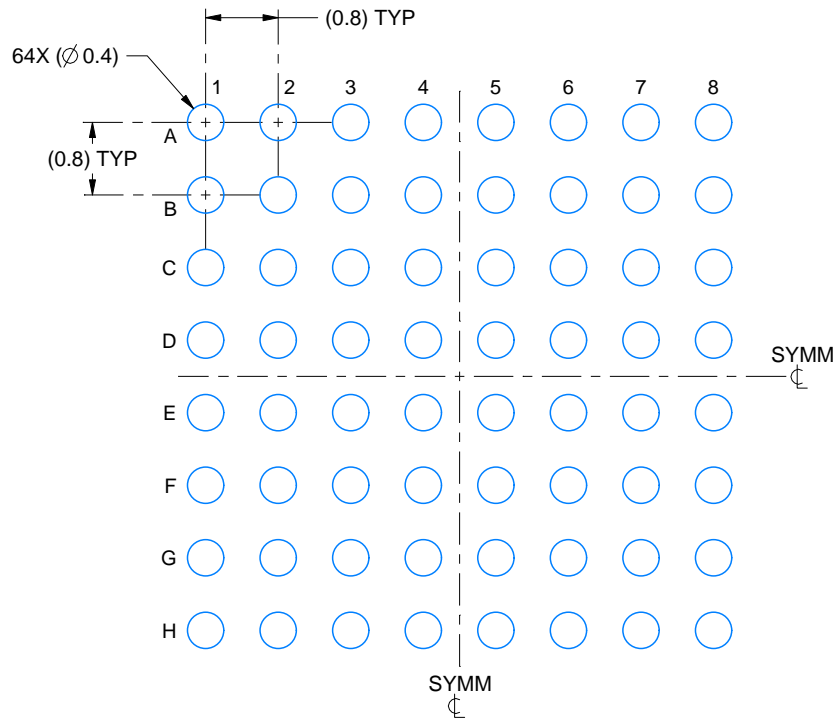

LAND PATTERN EXAMPLE
EXPOSED METAL SHOWN
SCALE:12X

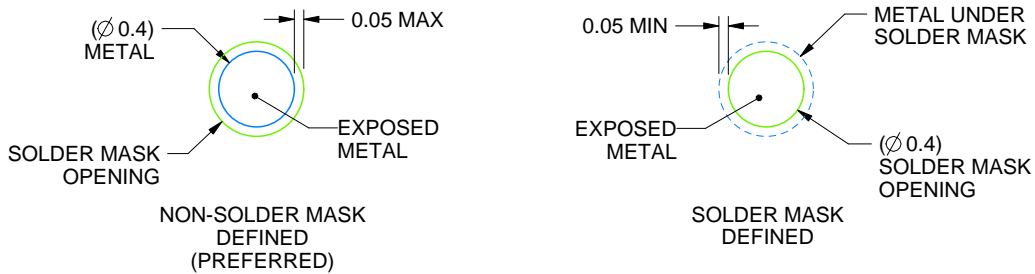

SOLDER MASK DETAILS
NOT TO SCALE

4220524/A 12/2018

NOTES: (continued)

- Final dimensions may vary due to manufacturing tolerance considerations and also routing constraints. For information, see Texas Instruments literature number SPRAA99 (www.ti.com/lit/spraa99).

EXAMPLE STENCIL DESIGN

GXG0064A

NFBGA - 1.45 mm max height

PLASTIC BALL GRID ARRAY

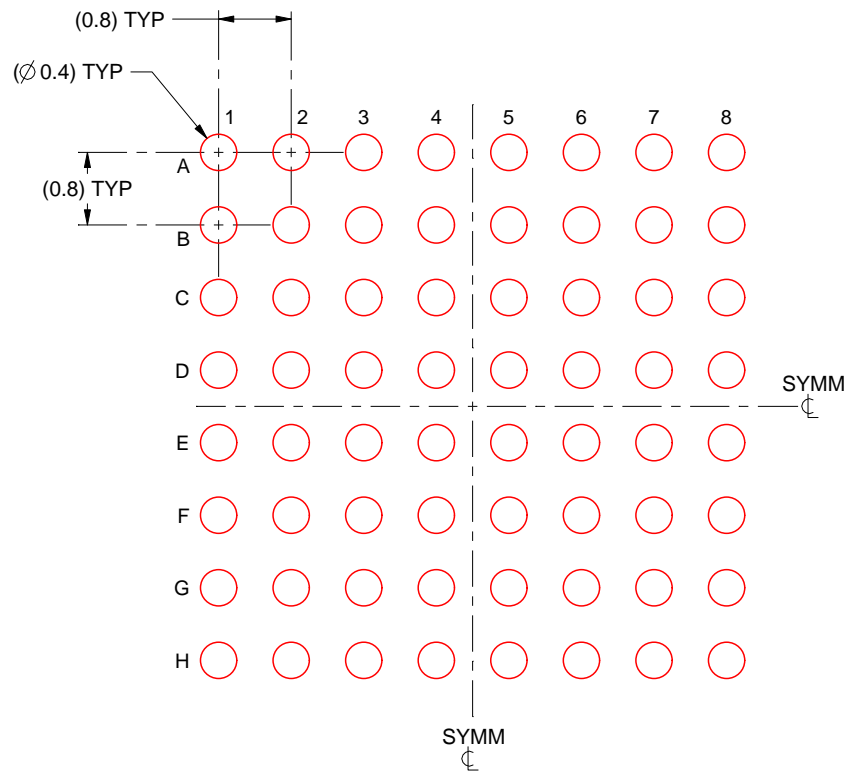

SOLDER PASTE EXAMPLE
BASED ON 0.125 mm THICK STENCIL
SCALE:12X

4220524/A 12/2018

NOTES: (continued)

4. Laser cutting apertures with trapezoidal walls and rounded corners may offer better paste release.

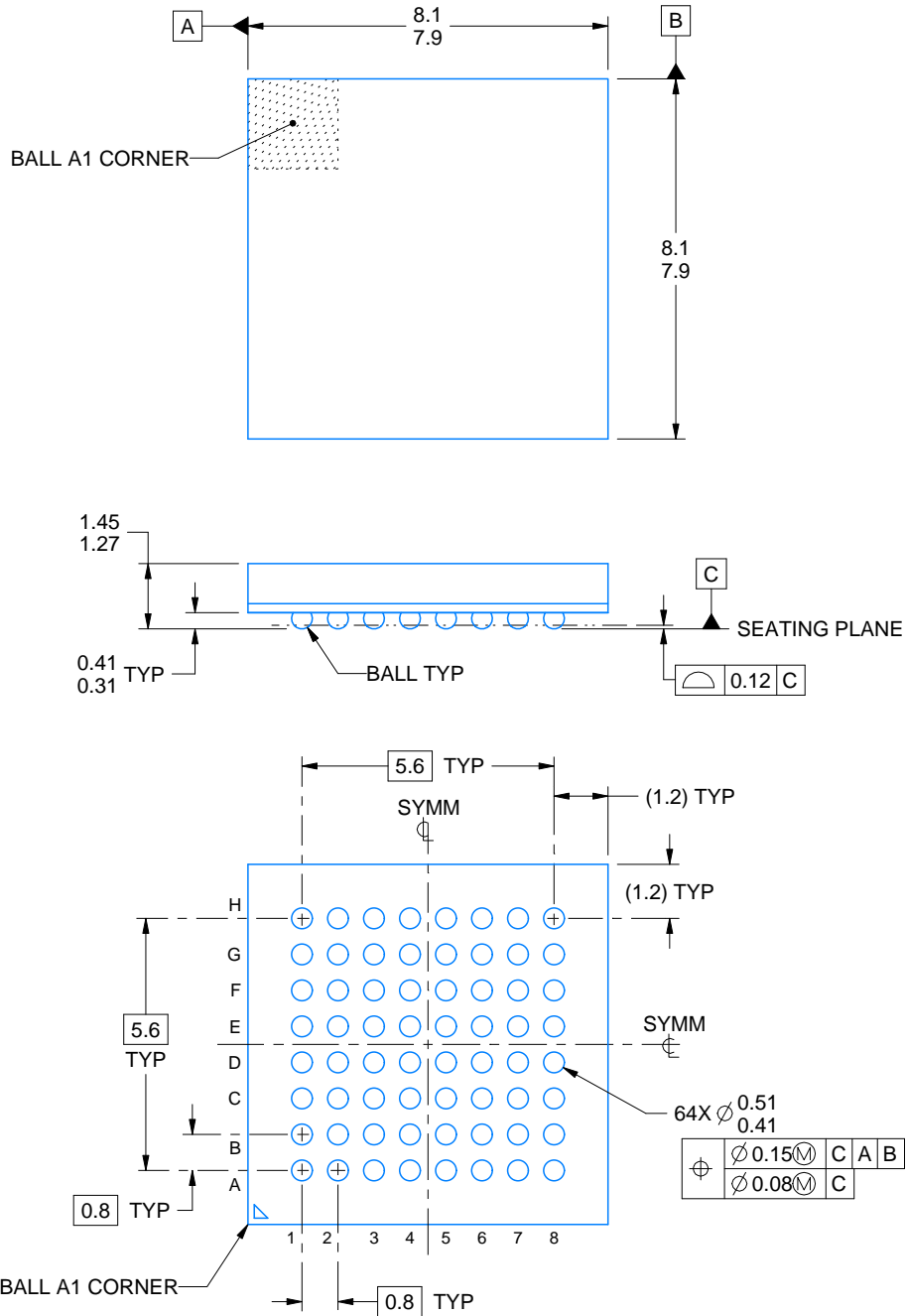
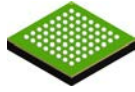

4220377/A 03/2023

NOTES:

1. All linear dimensions are in millimeters. Any dimensions in parenthesis are for reference only. Dimensioning and tolerancing per ASME Y14.5M.
2. This drawing is subject to change without notice.
3. This package is lead-free.

EXAMPLE BOARD LAYOUT

ZXG0064A

NFBGA - 1.45 mm max height

PLASTIC BALL GRID ARRAY

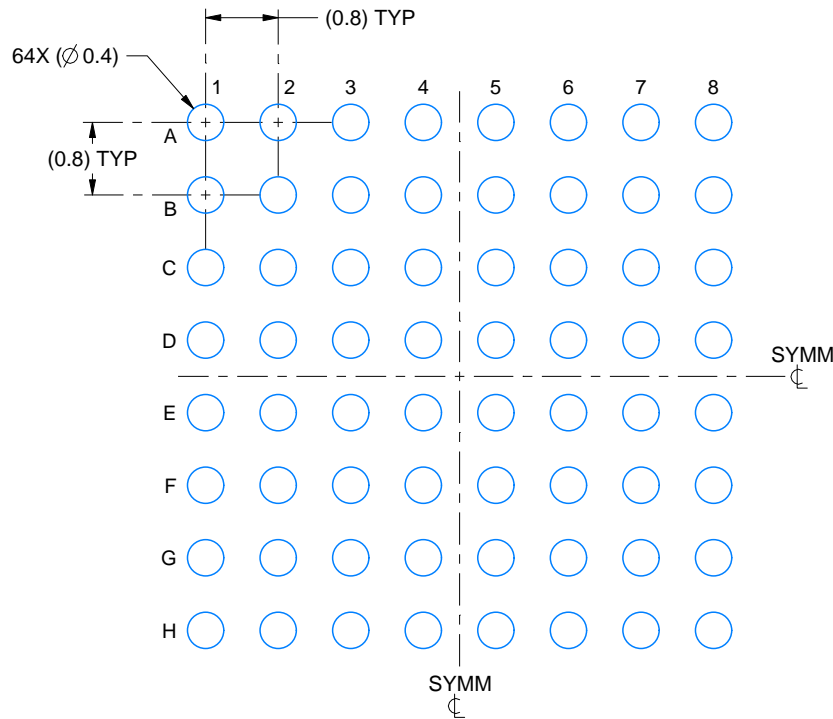

LAND PATTERN EXAMPLE
EXPOSED METAL SHOWN
SCALE:12X

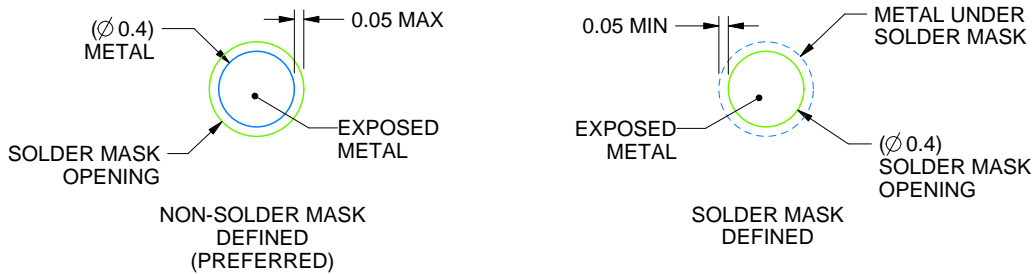

SOLDER MASK DETAILS
NOT TO SCALE

4220377/A 03/2023

NOTES: (continued)

- Final dimensions may vary due to manufacturing tolerance considerations and also routing constraints. For information, see Texas Instruments literature number SPRAA99 (www.ti.com/lit/spraa99).

EXAMPLE STENCIL DESIGN

ZXG0064A

NFBGA - 1.45 mm max height

PLASTIC BALL GRID ARRAY

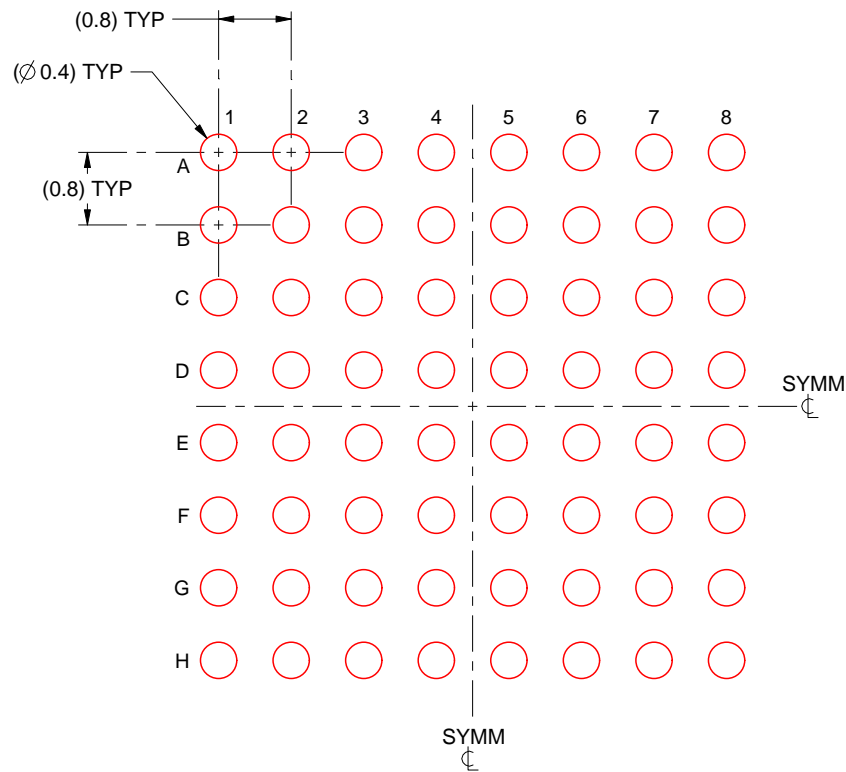

SOLDER PASTE EXAMPLE
BASED ON 0.125 mm THICK STENCIL
SCALE:12X

4220377/A 03/2023

NOTES: (continued)

5. Laser cutting apertures with trapezoidal walls and rounded corners may offer better paste release.

IMPORTANT NOTICE AND DISCLAIMER

TI PROVIDES TECHNICAL AND RELIABILITY DATA (INCLUDING DATA SHEETS), DESIGN RESOURCES (INCLUDING REFERENCE DESIGNS), APPLICATION OR OTHER DESIGN ADVICE, WEB TOOLS, SAFETY INFORMATION, AND OTHER RESOURCES "AS IS" AND WITH ALL FAULTS, AND DISCLAIMS ALL WARRANTIES, EXPRESS AND IMPLIED, INCLUDING WITHOUT LIMITATION ANY IMPLIED WARRANTIES OF MERCHANTABILITY, FITNESS FOR A PARTICULAR PURPOSE OR NON-INFRINGEMENT OF THIRD PARTY INTELLECTUAL PROPERTY RIGHTS.

These resources are intended for skilled developers designing with TI products. You are solely responsible for (1) selecting the appropriate TI products for your application, (2) designing, validating and testing your application, and (3) ensuring your application meets applicable standards, and any other safety, security, regulatory or other requirements.

These resources are subject to change without notice. TI grants you permission to use these resources only for development of an application that uses the TI products described in the resource. Other reproduction and display of these resources is prohibited. No license is granted to any other TI intellectual property right or to any third party intellectual property right. TI disclaims responsibility for, and you will fully indemnify TI and its representatives against, any claims, damages, costs, losses, and liabilities arising out of your use of these resources.

TI's products are provided subject to [TI's Terms of Sale](#) or other applicable terms available either on [ti.com](https://www.ti.com) or provided in conjunction with such TI products. TI's provision of these resources does not expand or otherwise alter TI's applicable warranties or warranty disclaimers for TI products.

TI objects to and rejects any additional or different terms you may have proposed.

Mailing Address: Texas Instruments, Post Office Box 655303, Dallas, Texas 75265
Copyright © 2024, Texas Instruments Incorporated