

DRV2510-Q1 3-A Automotive Haptic Driver for Solenoids and Voice Coils with Integrated Diagnostics

1 Features

- AEC-Q100 Qualified for automotive applications:
 - Temperature grade 1: -40°C to 125°C , T_A
- Wide operating voltage (4.5 V - 18 V)
- Integrated load-dump protection (40 V)
- High current drive (3 A Peak)
- Low $R_{DS(on)}$, full H-bridge output
- Integrated diagnostics
- Integrated fault protection
 - 40-V Load dump protection per ISO-7637-2
 - Short-circuit protection
 - Over-temperature protection
 - Over-voltage and under-voltage protection
 - Fault reporting
- Analog input
- I²C communication
- Dedicated interrupt pin
- ISO9000: 2002 TS16949 certified

2 Applications

- [Electromagnetic actuator driver](#)
 - Voice coil
 - Solenoid
- [Mechanical button replacement](#)
- [Automotive haptic applications](#)
 - Infotainment
 - Center-console
 - Steering wheel
 - Door-panel
 - Seats

3 Description

The DRV2510-Q1 device is a high current haptic driver specifically designed for inductive loads, such as solenoids and voice coils.

The output stage consists of a full H-bridge capable of delivering 3 A of peak current.

The DRV2510-Q1 device provides protection functions such as undervoltage lockout, over-current protection and over-temperature protection.

The DRV2510-Q1 device is automotive qualified. The integrated load-dump protection reduces external voltage clamp cost and size, and the onboard load diagnostics report the status of the actuator through the digital interface.

Device Information

PART NUMBER	PACKAGE ⁽¹⁾	BODY SIZE (NOM)
DRV2510-Q1	HTSSOP (16)	5.00 mm x 4.40 mm

- (1) For all available packages, see the orderable addendum at the end of the data sheet.

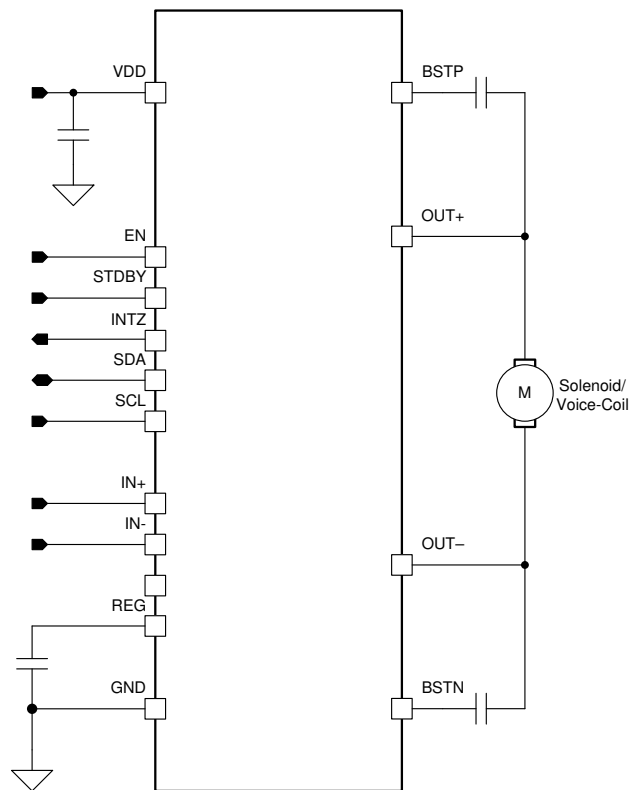

Simplified Schematic



Table of Contents

1 Features	1	7.5 Programming.....	14
2 Applications	1	7.6 Register Map.....	17
3 Description	1	8 Application and Implementation	20
4 Revision History	2	8.1 Application Information.....	20
5 Pin Configuration and Functions	4	8.2 Typical Applications.....	20
6 Specifications	5	9 Power Supply Recommendations	24
6.1 Absolute Maximum Ratings.....	5	10 Layout	24
6.2 ESD Ratings.....	5	10.1 Layout Guidelines.....	24
6.3 Recommended Operating Conditions.....	5	10.2 Layout Example.....	24
6.4 Thermal Information.....	5	11 Device and Documentation Support	25
6.5 Electrical Characteristics.....	6	11.1 Device Support.....	25
6.6 Timing Requirements.....	7	11.2 Receiving Notification of Documentation Updates..	25
6.7 Switching Characteristics.....	7	11.3 Support Resources.....	25
6.8 Typical Characteristics.....	8	11.4 Trademarks.....	25
7 Detailed Description	9	11.5 Electrostatic Discharge Caution.....	25
7.1 Overview.....	9	11.6 Glossary.....	25
7.2 Functional Block Diagram.....	9	12 Mechanical, Packaging, and Orderable Information	25
7.3 Feature Description.....	10		
7.4 Device Functional Modes.....	13		

4 Revision History

NOTE: Page numbers for previous revisions may differ from page numbers in the current version.

Changes from Revision C (May 2020) to Revision D (November 2023)	Page
• Updated the numbering format for tables, figures, and cross-references throughout the document.....	1

Changes from Revision B (September 2016) to Revision C (May 2020)	Page
• Moved automotive <i>Features</i> to the top of the Features list	1
• Added Junction temperature to the <i>Absolute Maximum Ratings</i>	5
• Changed the <i>ESD Ratings</i> table.....	5
• Added INTZ Report to the <i>Electrical Characteristics</i> table.....	6
• Changed Figure 7-1	10
• Changed From: "The load diagnostic function runs on de-assertion" To: "The load diagnostic function runs on assertion" in the <i>Load Diagnostics</i> section.....	11
• Added the <i>Protection and Monitoring</i> section.....	12
• Changed From: "NRST pin..." To: "EN pin..." in the <i>Operation in Shutdown Mode</i> section.....	13
• Changed From: When EN is asserted (logic low) To: When EN is de-asserted (logic low) in the <i>Operation in Shutdown Mode</i> section.....	13
• Deleted register 0x00 from the <i>Register Map</i> section.....	17
• Changed register <i>Address: 0x03</i>	19
• Changed the <i>Single-Ended Source</i> section and Figure 8-1	20
• Changed from: BSTA and BSTB to: BSTP and BSTN in the <i>Capacitor Selection</i> section.....	21
• Changed the <i>Differential Input Diagram</i> section and Figure 8-6	23

Changes from Revision A (June 2016) to Revision B (September 2016) **Page**

- Changed Feature From: Automotive Qualified (Q100) To: Qualified According to AEC-Q100 Grade 2..... 1
- Changed Feature From: Wide Operating Voltage (5 V – 18 V) To: Wide operating voltage (4.5 V – 18 V)..... 1
- Added Feature: ISO9000: 2002 TS16949 certified 1
- Changed the VDD MIN value From: 5 V to: 4.5 V in the [Section 6.3](#) 5
- Changed From: operates from 5 V – 18 V To: operates from 4.5 V – 18 V in the [Section 9](#) 24

Changes from Revision * (June 2016) to Revision A (June 2016) **Page**

- Released as Production Data. 1
-

5 Pin Configuration and Functions

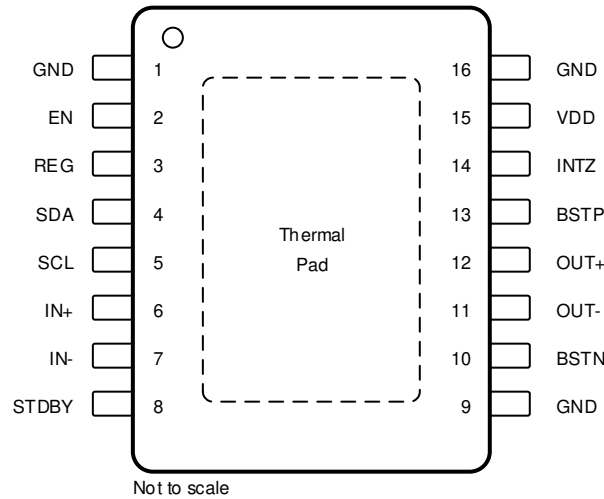

Figure 5-1. TWP Package HTSSOP 16-Pin With Thermal Pad Top View

Table 5-1. Pin Functions

PIN		TYPE	DESCRIPTION
NAME	NO.		
GND	1, 9, 16	P	Ground.
EN	2	I	Device enable pin.
REG	3	P	Internally generated gate voltage supply. Not to be used as a supply or connected to any component other than a 1 μ F X7R ceramic decoupling capacitor and the MODE resistor divider.
SDA	4	I	I ² C data.
SCL	5	I	I ² C clock.
IN+	6	I	Positive differential input.
IN-	7	I	Negative differential input.
STDBY	8	I	Standby pin.
BSTN	10	P	Boot strap for negative output, connect to 220 nF X5R, or better ceramic cap to OUT-.
OUT-	11	O	Negative output.
OUT+	12	O	Positive output.
BSTP	13	P	Boot strap for positive output, connect to 220 nF X5R, or better ceramic cap to OUT+.
INTZ	14	O	General fault reporting. Open drain. INTZ = High, normal operation INTZ = Low, fault condition
VDD	15	P	Power supply.
Thermal Pad		G	Connect to GND for best system performance. If not connected to GND, leave floating.

6 Specifications

6.1 Absolute Maximum Ratings

over operating free-air temperature range (unless otherwise noted)⁽¹⁾

		MIN	MAX	UNIT
Supply voltage	VDD DC supply voltage range	-0.3	30	V
	VDD pulsed supply voltage range. t < 400 ms exposure	-1	40	
	VDD supply voltage ramp rate		15	V/ms
Input voltage, V _I	SCL, SDA, EN	-0.3	5	V
	IN+, IN-, STDBY	-0.3	6.5	
Current	DC current on VDD, GND, OUT+, OUT-	-4	4	A
	Maximum current in all input pins	-1	1	mA
	Maximum sink current for open-drain pins		7	
Operating free-air temperature, T _A		-40	125	°C
Junction temperature, T _J		-40	150	
Storage temperature range, T _{stg}		-55	150	

- (1) Stresses beyond those listed under *Absolute Maximum Ratings* may cause permanent damage to the device. These are stress ratings only, which do not imply functional operation of the device at these or any other conditions beyond those indicated under *Recommended Operating Conditions*. Exposure to absolute-maximum-rated conditions for extended periods may affect device reliability.

6.2 ESD Ratings

		VALUE	UNIT
V _(ESD) Electrostatic discharge	Human body model (HBM), per AEC Q100-002 ⁽¹⁾ HBM ESD Classification Level H2	±3500	V
	Charged device model (CDM), per AEC Q100-011 CDM ESD Classification Level C4B	±1000	

- (1) AEC Q100-002 indicates that HBM stressing shall be in accordance with the ANSI/ESDA/JEDEC JS-001 specification.

6.3 Recommended Operating Conditions

over operating free-air temperature range (unless otherwise noted)

		MIN	NOM	MAX	UNIT
VDD	Supply voltage. VDD.	4.5		18	V
V _{IH}	High-level input voltage. SDA, SCL, STDBY, EN.	2.1			V
V _{IL}	Low-level input voltage. SDA, SCL, STDBY, EN			0.7	V
V _{OL}	Low-level output voltage			0.4	V
V _{OH}	High-level output voltage	2.4			V
I _{IH}	High-level input current. SDA, SCL, STDBY, EN			50	µA
R _L	Minimum load impedance		1.5		Ω
C _B	Load capacitance for each bus line (SDA/SCL)			400	pF

6.4 Thermal Information

THERMAL METRIC ⁽¹⁾		DRV2510-Q1	UNIT
		PWP (HTSSOP)	
		{16} PINS	
R _{θJA}	Junction-to-ambient thermal resistance	39.4	°C/W
R _{θJC(top)}	Junction-to-case (top) thermal resistance	24.9	°C/W
R _{θJB}	Junction-to-board thermal resistance	20	°C/W
ψ _{JT}	Junction-to-top characterization parameter	0.6	°C/W
ψ _{JB}	Junction-to-board characterization parameter	19.8	°C/W

THERMAL METRIC ⁽¹⁾		DRV2510-Q1	UNIT
		PWP (HTSSOP)	
		{16} PINS	
R _{θJC(bot)}	Junction-to-case (bottom) thermal resistance	2	°C/W

(1) For more information about traditional and new thermal metrics, see the [Semiconductor and IC Package Thermal Metrics](#) application report.

6.5 Electrical Characteristics

T_A = 25°C, AVCC = VDD = 12 V, R_L = 5 Ω (unless otherwise noted)

PARAMETER		TEST CONDITIONS	MIN	TYP	MAX	UNIT
V _{OS}	Output offset voltage (measured differentially)	V _I = 0 V, Gain = 20 dB	-25		25	mV
I _{VDD}	Quiescent supply current	No load or filter		16		mA
I _{VDD(SD)}	Quiescent supply current in shutdown mode	No load or filter		5	20	μA
I _{VDD(STD BY)}	Quiescent supply current in standby mode	No load or filter		7		mA
r _{DS(on)}	Drain-source on-state resistance, measured pin to pin	T _J = 25°C		180		mΩ
G	Gain	P _(o) = 1 W	19	20	21	dB
			25	26	27	
			31	32	33	dB
			35	36	37	
V _{REG}	Regulator voltage		6.4	6.9	7.4	V
V _O	Output voltage (measured differentially)			20		V
PSRR	Power supply ripple rejection	VDD = 12 V + 1 Vrms at 1 kHz		75		dB
V _{ICMIN}	Input common-mode min			0.3		V
V _{ICMAX}	Input common-mode max			4.4		
CMRR	Common-mode rejection ratio	f = 1 kHz, 100 mVrms referenced to GND. Gain = 20 dB		63		dB
f _{OSC}	Oscillator frequency (with PWM duty cycle < 96%)			400		kHz
				500		
	Output resistance in shutdown			10		MΩ
	Resistance to detect a short from OUT pin(s) to VDD or GND				200	Ω
	Open-circuit detection threshold		75	95	120	Ω
	Short-circuit detection threshold		0.9	1.2	1.5	Ω
	Power-on threshold			4.1		V
	Thermal trip point			150		°C
	Thermal hysteresis			15		°C
	Over-current trip point			3.5		A
	Over-voltage trip point			21		V
	Over-voltage hysteresis			0.6		V
	Under-voltage trip point			4		V
	Under-voltage hysteresis			0.25		V
INTZ Report						
	INTZ pin output voltage for logic-level high (open-drain logic output)	External 47-kΩ pullup resistor to 3.3 V	2.4			V
	INTZ pin output voltage for logic-level low (open-drain logic output)	External 47-kΩ pullup resistor to 3.3 V			0.5	V

6.6 Timing Requirements

$T_A = 25\text{ }^\circ\text{C}$, $V_{DD} = 3.6\text{ V}$ (unless otherwise noted)

		MIN	NOM	MAX	UNIT
$f_{(SCL)}$	Frequency at the SCL pin with no wait states			400	kHz
$t_{w(H)}$	Pulse duration, SCL high	0.6			μs
$t_{w(L)}$	Pulse duration, SCL low	1.3			μs
$t_{su(1)}$	Setup time, SDA to SCL	100			ns
$t_{h(1)}$	Hold time, SCL to SDA	300			ns
$t_{(BUF)}$	Bus free time between stop and start condition	1.3			μs
$t_{su(2)}$	Setup time, SCL to start condition	0.6			μs
$t_{h(2)}$	Hold time, start condition to SCL	0.6			μs
$t_{su(3)}$	Setup time, SCL to stop condition	0.6			μs

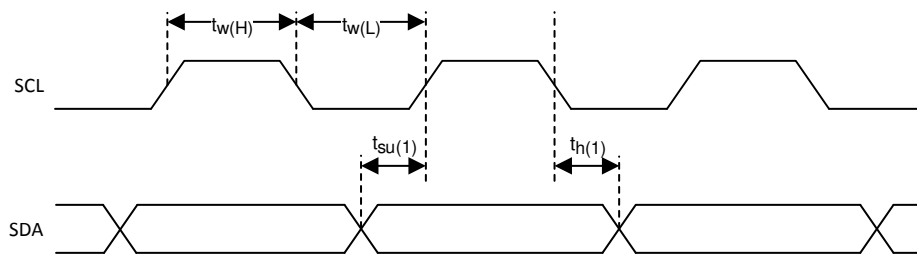

Figure 6-1. SCL and SDA Timing

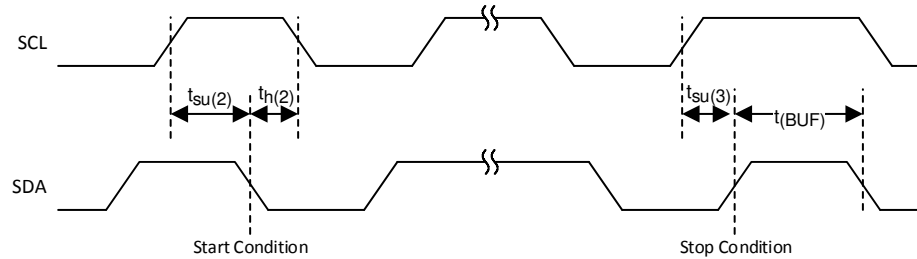

Figure 6-2. Timing for Start and Stop Conditions

6.7 Switching Characteristics

over operating free-air temperature range (unless otherwise noted)

PARAMETER	TEST CONDITIONS	MIN	TYP	MAX	UNIT
t_{on-sd}	Turn-on time from shutdown to waveform EN = Low to High, STBY = Low		229		ms
t_{OFF-sd}	Turn-off time EN = High to Low		47		μs
$t_{on-stbby}$	Turn-on time from standby to waveform EN = High, STBY = High to Low		32		μs

6.8 Typical Characteristics

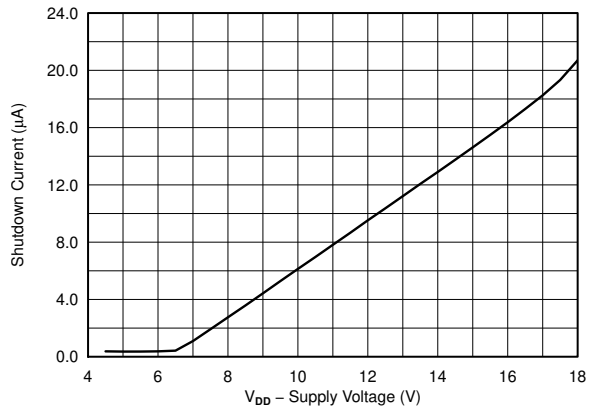

Figure 6-3. Shutdown Current vs VDD Voltage

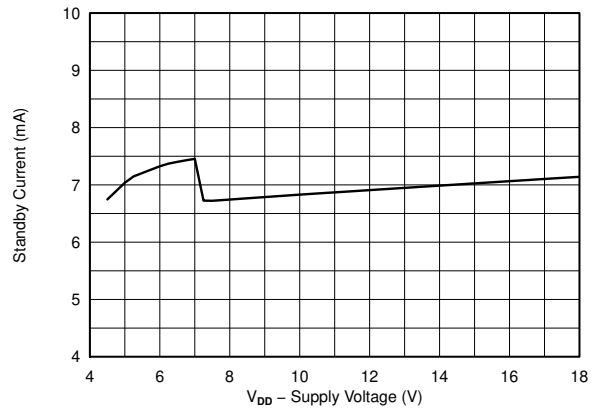

Figure 6-4. Standby Current vs VDD Voltage

7 Detailed Description

7.1 Overview

The DRV2510-Q1 device is a high current haptic driver specifically designed for inductive loads, such as solenoids and voice coils.

The output stage consists of a full H-bridge capable of delivering 3 A of peak current.

The design uses an ultra-efficient switching output technology developed by Texas Instruments, but with features added for the automotive industry. The DRV2510-Q1 device provides protection functions such as undervoltage lockout, over-current protection and over-temperature protection. This technology allows for reduced power consumption, reduced heat, and reduced peak currents in the electrical system.

The DRV2510-Q1 device is automotive qualified. The integrated load-dump protection reduces external voltage clamp cost and size, and the onboard load diagnostics report the status of the actuator through the digital interface.

7.2 Functional Block Diagram

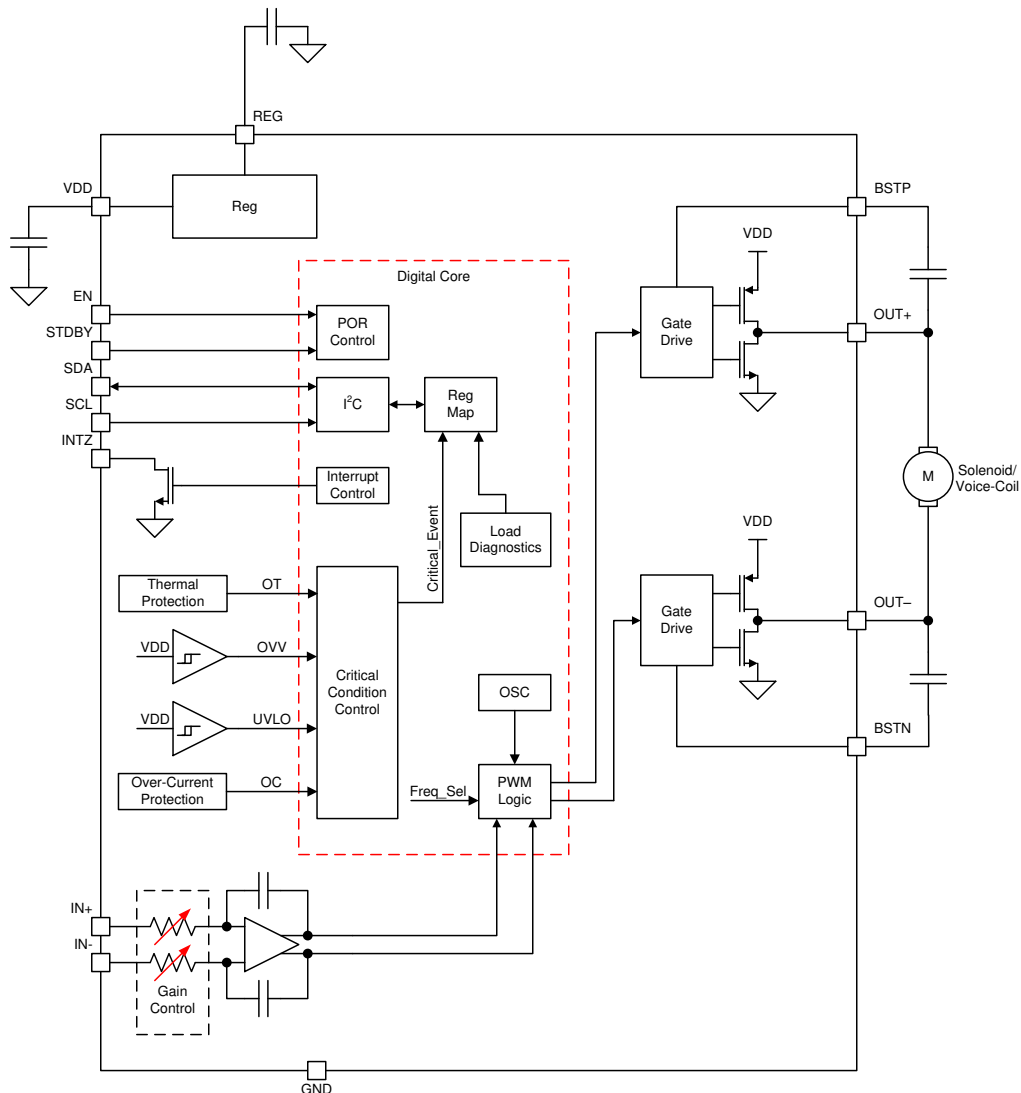

Copyright © 2016, Texas Instruments Incorporated

7.3 Feature Description

7.3.1 Analog Input and Configurable Pre-amplifier

The DRV2510-Q1 device features a differential input stage that cancels common-mode noise that appears on the inputs. The DRV2510-Q1 device also features four gain settings that are configurable via I²C. Please see the Programming Sections for register locations.

Table 7-1. Gain Configuration Table

GAIN	INPUT IMPEDANCE
20 dB	60 kΩ
26 dB	30 kΩ
32 dB	15 kΩ
36 dB	9 kΩ

7.3.2 Pulse-Width Modulator (PWM)

The DRV2510-Q1 device features BD modulation scheme with high bandwidth, low noise, low distortion, and excellent stability.

The BD modulation scheme allows for smaller ripple currents through the load. Each output switches from 0 V to the supply voltage. With no input, the OUT+ and OUT- pins are in phase with each other so that there is little or no current in the load. For positive differential inputs, the duty cycle of OUT+ is greater than 50% and the duty cycle of OUT- is lower than 50% for a positive differential output voltage. The opposite is true for negative differential inputs. The voltage across the load sits at 0 V throughout most of the switching period, reducing the switching current, which reduces the I²R losses in the load.

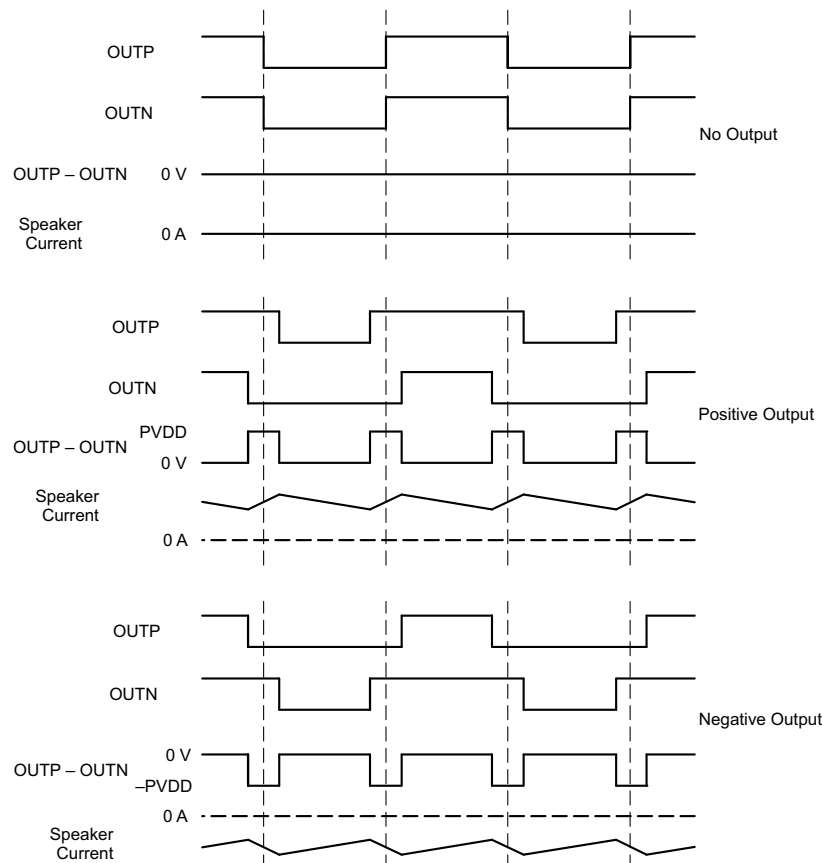

Figure 7-1. BD Mode Modulation

7.3.3 Designed for low EMI

The DRV2510-Q1 device design has minimal parasitic inductances due to the short leads on the package. This dramatically reduces EMI that results from current passing from the die to the system PCB. The design incorporates circuitry that optimizes output transitions that causes EMI. Follow the recommended design requirements in the [Section 8.2.1.1](#) section.

7.3.4 Device Protection Systems

The DRV2510-Q1 device features a complete set of protection circuits carefully designed to protect the device against permanent failures due to shorts, over-temperature, over-voltage, and under-voltage scenarios. The INTZ pin signals if an error is detected.

Additionally, the DRV2510-Q1 device is not damaged by adjacent pin to pin shorts.

Table 7-2. Fault Reporting Table

FAULT	TRIGGERING CONDITION	INTZ	ACTION
Over-current	Output short or short to VDD or GND	pulled low	output in high impedance. I ² updated.
Over-temperature	T _j > 150 °C	pulled low	output in high impedance. Recovery is automatic once the temperature returns to a safe level.
Under-voltage	VDD < 4 V	pulled low	output in high impedance. I ² reset.
Over-voltage	VDD > 21 V	pulled low	output in high impedance. I ² updated.

7.3.4.1 Diagnostics

The device incorporates load diagnostic circuitry designed for detecting and determining the status of output connections. The device supports the following diagnostics:

- Short to GND
- Short to VDD
- Short across load
- Open load

The device reports the presence of any of the short or open conditions to the system via I²C register read.

7.3.4.1.1 Load Diagnostics

The load diagnostic function runs on assertion of EN or when the device is in a fault state (dc detect, overcurrent, overvoltage, undervoltage, and overtemperature). During this test, the outputs are in a Hi-Z state. The device determines whether the output is a short to GND, short to VDD, open load, or shorted load. The load diagnostic biases the output, which therefore requires limiting the capacitance value for proper functioning. The load diagnostic test takes approximately 229 ms to run. Note that the *check* phase repeats up to five times if a fault is present or a large capacitor to GND is present on the output. On detection of an open load, the output still operates. On detection of any other fault condition, the output goes into a Hi-Z state, and the device checks the load continuously until removal of the fault condition. After detection of a normal output condition, the output starts. The load diagnostics run after every other overvoltage (OV) event. The load diagnostic for open load only has I²C reporting. All other faults have I²C and INTZ pin assertion.

The device performs load diagnostic tests as shown in [Figure 7-2](#).

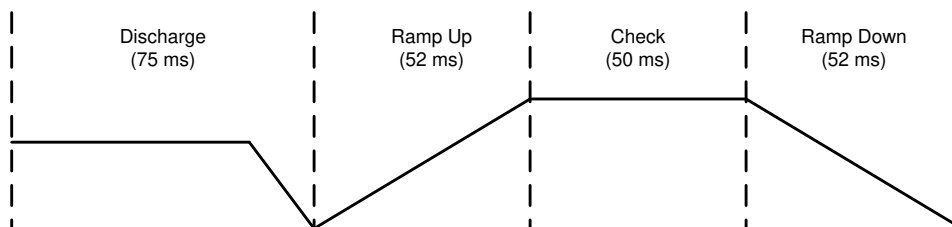

Figure 7-2. Load Diagnostics Sequence of Events

Figure 7-3 illustrates how the diagnostics determine the load based on output conditions.

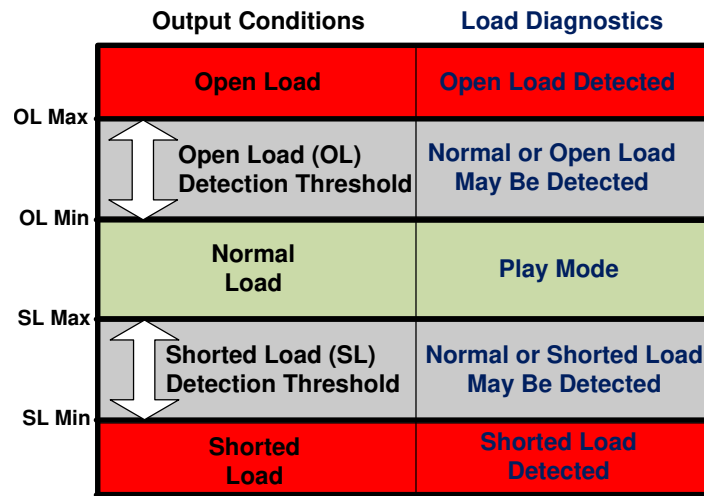

Figure 7-3. Load Diagnostic Reporting Thresholds

7.3.4.2 Faults During Load Diagnostics

If the device detects a fault (overtemperature, overvoltage, undervoltage) during the load diagnostics test, the device exits the load diagnostics, which may result in a small transient on the output.

7.3.4.3 Protection and Monitoring

- **Overcurrent Shutdown (OCSD)**—The overcurrent shutdown forces the output into Hi-Z. The device asserts the INTZ pin and updates the I²C register.
- **DC Detect**—This circuit checks for a dc offset continuously during normal operation at the output of the amplifier. If a dc offset occurs, the device asserts the INTZ pin and updates the I²C register. Note that the dc detection threshold follows VDD changes.
- **Overtemperature Shutdown (OTSD)**—The device shuts down when the die junction temperature reaches the overtemperature threshold. The device asserts the INTZ pin and updates I²C register. Recovery is automatic when the temperature returns to a safe level.
- **Undervoltage (UV)**—The undervoltage (UV) protection detects low voltages on VDD. In the event of an undervoltage condition, the device asserts the INTZ pin and resets the I²C register.
- **Power-On Reset (POR)**—Power-on reset (POR) occurs when VDD drops below the POR threshold. A POR event causes the I²C bus to go into a high-impedance state. After recovery from the POR event, the device restarts automatically with default I²C register settings. The I²C is active as long as the device is not in POR.
- **Overvoltage (OV) and Load Dump**—OV protection detects high voltages on VDD. If VDD reaches the overvoltage threshold, the device asserts the INTZ pin and updates the I²C register. The device can withstand 40-V load-dump voltage spikes.
- **SpeakerGuard™**—This protection circuitry limits the output voltage to the value selected in I²C register 0x03. This value determines both the positive and negative limits. The user can use the SpeakerGuard feature to improve battery life or protect the actuator from exceeding its excursion limits.
- **Adjacent-Pin Shorts**—The device design is such that shorts between adjacent pins do not cause damage.

7.4 Device Functional Modes

The DRV2510-Q1 device has multiple power states to optimize power consumption.

7.4.1 Operation in Shutdown Mode

The EN pin of the DRV2510-Q1 device puts the device in a shutdown mode. When EN is de-asserted (logic low), all internal blocks of the device are off to achieve ultra low power. I²C is not operational in this mode and the output is in Hi-Z state.

7.4.2 Operation in Standby Mode

The STDBY pin of the DRV2510-Q1 device puts the device in a standby mode. When STDBY is asserted (logic high), some internal blocks of the device are off to achieve low power while preserving the ability to wake up quickly to achieve low latency waveform playback.

7.4.3 Operation in Active Mode

The DRV2510-Q1 device is in active mode when it has a valid supply, and it is not in either shutdown or standby modes. In this mode the DRV2510-Q1 device is fully on and reproducing at the output the input times the gain.

7.5 Programming

7.5.1 General I²C Operation

The I²C bus employs two signals, SDA (data) and SCL (clock), to communicate between integrated circuits in a system. The bus transfers data serially, one bit at a time. The 8-bit address and data bytes are transferred with the most-significant bit (MSB) first. In addition, each byte transferred on the bus is acknowledged by the receiving device with an acknowledge bit. Each transfer operation begins with the master device driving a start condition on the bus and ends with the master device driving a stop condition on the bus. The bus uses transitions on the data pin (SDA) while the clock is at logic high to indicate start and stop conditions. A high-to-low transition on the SDA signal indicates a start, and a low-to-high transition indicates a stop. Normal data-bit transitions must occur within the low time of the clock period. Figure 7-4 shows a typical sequence. The master device generates the 7-bit slave address and the read-write (R/W) bit to start communication with a slave device. The master device then waits for an acknowledge condition. The slave device holds the SDA signal low during the acknowledge clock period to indicate acknowledgment. When the acknowledgment occurs, the master transmits the next byte of the sequence. Each device is addressed by a unique 7-bit slave address plus a R/W bit (1 byte). All compatible devices share the same signals through a bidirectional bus using a wired-AND connection.

The number of bytes that can be transmitted between start and stop conditions is not limited. When the last word transfers, the master generates a stop condition to release the bus. Figure 7-4 shows a generic data-transfer sequence.

Use external pull-up resistors for the SDA and SCL signals to set the logic-high level for the bus. Pull-up resistors between 660 Ω and 4.7 k Ω are recommended. Do not allow the SDA and SCL voltages to exceed the DRV2510-Q1 supply voltage, V_{DD} .

Note

The DRV2510-Q1 slave address is 0x6C (7-bit), or 1101100 in binary.

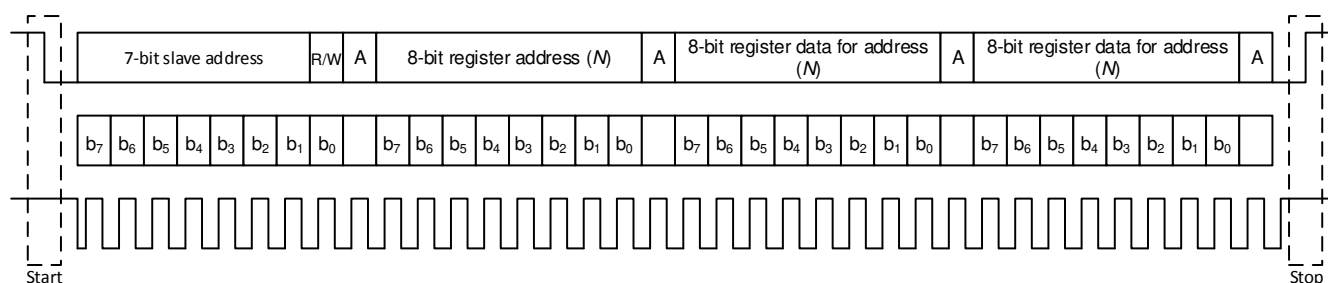

Figure 7-4. Typical I²C Sequence

The DRV2510-Q1 device operates as an I²C-slave 1.8-V logic thresholds, but can operate up to the V_{DD} voltage. The device address is 0x5A (7-bit), or 1011010 in binary which is equivalent to 0xB4 (8-bit) for writing and 0xB5 (8-bit) for reading.

7.5.2 Single-Byte and Multiple-Byte Transfers

The serial control interface supports both single-byte and multiple-byte R/W operations for all registers.

During multiple-byte read operations, the DRV2510-Q1 device responds with data one byte at a time and begins at the signed register. The device responds as long as the master device continues to respond with acknowledges.

The DRV2510-Q1 supports sequential I²C addressing. For write transactions, a sequential I²C write transaction has taken place if a register is issued followed by data for that register as well as the remaining registers that follow. For I²C sequential-write transactions, the register issued then serves as the starting point and the amount of data transmitted subsequently before a stop or start is transmitted determines how many registers are written.

7.5.3 Single-Byte Write

As shown in Figure 7-5, a single-byte data-write transfer begins with the master device transmitting a start condition followed by the I²C device address and the read-write bit. The read-write bit determines the direction of the data transfer. For a write-data transfer, the read-write bit must be set to 0. After receiving the correct I²C device address and the read-write bit, the DRV2510-Q1 responds with an acknowledge bit. Next, the master transmits the register byte corresponding to the DRV2510-Q1 internal-memory address that is accessed. After receiving the register byte, the device responds again with an acknowledge bit. Finally, the master device transmits a stop condition to complete the single-byte data-write transfer.

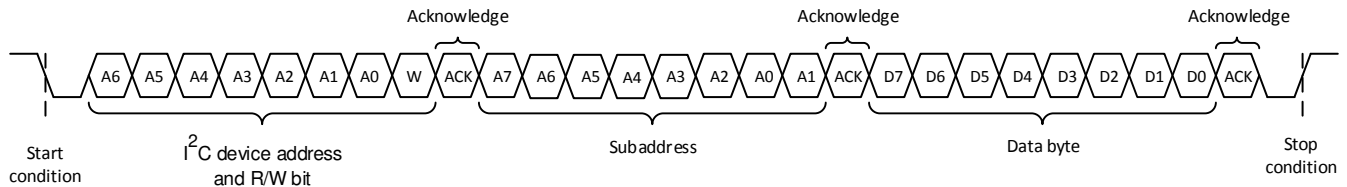

Figure 7-5. Single-Byte Write Transfer

7.5.4 Multiple-Byte Write and Incremental Multiple-Byte Write

A multiple-byte data write transfer is identical to a single-byte data write transfer except that multiple data bytes are transmitted by the master device to the DRV2510-Q1 device as shown in Figure 7-6. After receiving each data byte, the DRV2510-Q1 device responds with an acknowledge bit.

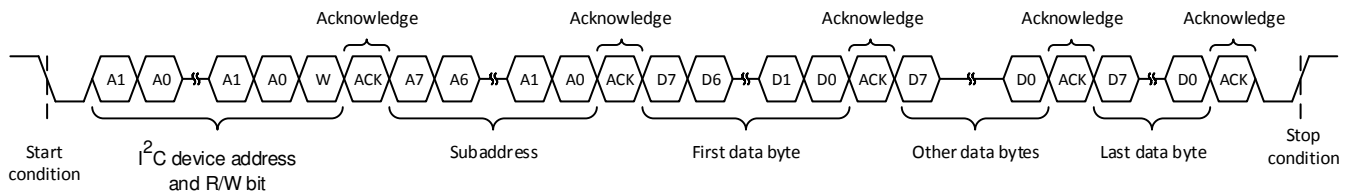

Figure 7-6. Multiple-Byte Write Transfer

7.5.5 Single-Byte Read

Figure 7-7 shows that a single-byte data-read transfer begins with the master device transmitting a start condition followed by the I²C device address and the read-write bit. For the data-read transfer, both a write followed by a read actually occur. Initially, a write occurs to transfer the address byte of the internal memory address to be read. As a result, the read-write bit is set to 0.

After receiving the DRV2510-Q1 address and the read-write bit, the DRV2510-Q1 device responds with an acknowledge bit. The master then sends the internal memory address byte, after which the device issues an acknowledge bit. The master device transmits another start condition followed by the DRV2510-Q1 address and the read-write bit again. On this occasion, the read-write bit is set to 1, indicating a read transfer. Next, the DRV2510-Q1 device transmits the data byte from the memory address that is read. After receiving the data byte, the master device transmits a not-acknowledge followed by a stop condition to complete the single-byte data read transfer. See the note in the Section 7.5.1 section.

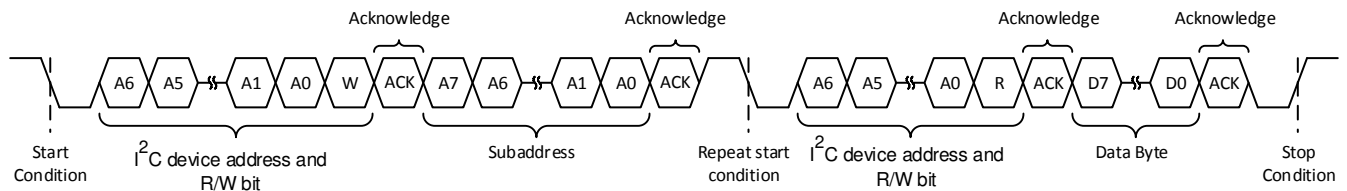

Figure 7-7. Single-Byte Read Transfer

7.5.6 Multiple-Byte Read

A multiple-byte data-read transfer is identical to a single-byte data-read transfer except that multiple data bytes are transmitted by the DRV2510-Q1 device to the master device as shown in Figure 7-8. With the exception of the last data byte, the master device responds with an acknowledge bit after receiving each data byte.

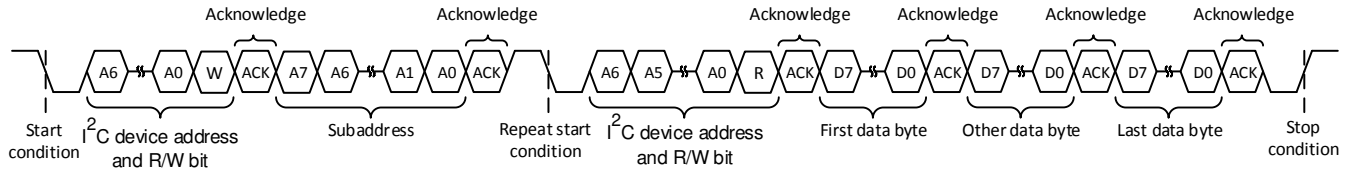

Figure 7-8. Multiple-Byte Read Transfer

7.6 Register Map

Table 7-3. Register Map Overview

REG NO.	DEFAULT	BIT 7	BIT 6	BIT 5	BIT 4	BIT 3	BIT 2	BIT 1	BIT 0
0x01	0x00	OVER_TEMP	DC_OFFSET	OVER_VOLT	UNDER_VOLT	OVER_CURR	LOAD_DIAG	Reserved	
0x02	0x00	DEV_ACTIVE	STDBY	DIAG_ACTIVE	FAULT	LOAD_SHORT	LOAD_OPEN	LOAD_SHORT_GND	LOAD_SHORT_VDD
0x03	0x00	GAIN[1:0]		PEAK_PROTECTION[1:2]			Reserved		FREQ_SEL

7.6.1 Address: 0x01

Figure 7-9. 0x01

7	6	5	4	3	2	1	0
OVER_TEMP[0]	DC_OFFSET[0]	OVER_VOLT[0]	UNDER_VOLT[0]	OVER_CURR[0]	LOAD_DIAG[0]	Reserved	
RO-0	RO-0	RO-0	RO-0	RO-0	RO-0		

Table 7-4. Address: 0x01

BIT	FIELD	TYPE	DEFAULT	DESCRIPTION	
7	OVER_TEMP	RO	0	Shows the current status of the thermal protection	
				0	Temperature is below the over-temperature threshold.
				1	Temperature is above the over-temperature threshold.
6	DC_OFFSET	RO	0	Shows the status of DC offset protection	
				0	DC offset protection has not occurred.
				1	DC offset protection has occurred.
5	OVER_VOLT	RO	0	Shows the status of the over-voltage protection.	
				0	VDD voltage is below the over-voltage threshold.
				1	VDD voltage is above the over-voltage threshold.
4	UNDER_VOLT	RO	0	Shows the status of the under-voltage protection.	
				0	VDD voltage is above the under-voltage threshold.
				1	VDD voltage is below the under-voltage threshold.
3	OVER_CURR	RO	0	Shows the status of the over-current protection.	
				0	An over-current event has not occurred.
				1	Device shutdown due to over-current.
2	LOAD_DIAG	RO	0	Shows the status of the load diagnostics.	
				0	An open or short has not been detected.
				1	An open or short was detected.
1:0	Reserved				

7.6.2 Address: 0x02

Figure 7-10. 0x02

7	6	5	4	3	2	1	0
DEV_ACTIVE [0]	STDBY [0]	DIAG_ACTIVE [0]	FAULT [0]	LOAD_SHORT [0]	LOAD_OPEN [0]	LOAD_SHORT_GND [0]	LOAD_SHORT_VDD [0]
RO-0	RO-0	RO-0	RO-0	RO-0	RO-0	RO-0	RO-0

Table 7-5. Address: 0x02

BIT	FIELD	TYPE	DEFAULT	DESCRIPTION	
7	DEV_ACTIVE	RO	0	Shows the device status (active or shutdown).	
				0	Device is shutdown.
				1	Device is active.
6	STDBY	RO	0	Shows the device standby status.	
				0	Device is not on standby.
				1	Device is on standby.
5	DIAG_ACTIVE	RO	0	Shows the status of the diagnosis engine.	
				0	Not performing load diagnostics.
				1	Performing load diagnostics.
4	FAULT	RO	0	Shows if a fault has occurred on the system. Either over-voltage, under-voltage, over-current, over-temperature.	
				0	No fault has occurred.
				1	A fault has occurred.
3	LOAD_SHORT	RO	0	Shows whether the output is shorted.	
				0	OUT+ is not shorted to OUT-.
				1	OUT+ is shorted to OUT-.
2	LOAD_OPEN	RO	0	Shows whether the output has a proper load connected.	
				0	A proper load is connected between OUT+ and OUT-.
				1	There is an open connection between OUT+ and OUT-.
1	LOAD_SHORT_GND	RO	0	Shows whether the output is shorted to GND.	
				0	Output is not shorted to GND.
				1	Either OUT+ or OUT- is shorted to GND.
0	LOAD_SHORT_VDD	RO	0	Shows whether the output is shorted to VDD.	
				0	Output is not shorted to VDD.
				1	Either OUT+ or OUT- is shorted to VDD.

7.6.3 Address: 0x03

Figure 7-11. 0x03

7	6	5	4	3	2	1	0
GAIN[1:0]		PEAK_PROTECTION[2:0]			Reserved		FREQ_SEL[0]
R/W-0		R/W-0			R/W-0		R/W-0

Table 7-6. Address: 0x03

BIT	FIELD	TYPE	DEFAULT	DESCRIPTION	
7:6	GAIN[1:0]	R/W	01	Sets the gain.	
				0	20 dB.
				1	26 dB.
				2	32 dB.
				3	36 dB.
5:3	PEAK_PROTECTION[2:0]	R/W	111	Sets the peak output protection.	
				0	5V pk
				1	5.9 Vpk
				2	7 Vpk
				3	8.4 Vpk
				4	9.8 Vpk
				5	11.8 Vpk
				6	14 Vpk
7	Protection disabled				
2:1	Reserved		00	Always write default values	
0	FREQ_SEL	R/W	0	Sets the output frequency.	
				0	400 kHz.
				1	500 kHz.

8 Application and Implementation

Note

Information in the following applications sections is not part of the TI component specification, and TI does not warrant its accuracy or completeness. TI's customers are responsible for determining suitability of components for their purposes, as well as validating and testing their design implementation to confirm system functionality.

8.1 Application Information

The DRV2510-Q1 device is a high-efficiency driver for inductive loads, such as solenoids and voice-coils. The typical use of the device is on haptic applications where short, strong waveforms are desired to create a haptic event that will be coming from the application processor.

8.2 Typical Applications

8.2.1 Single-Ended Source

To use the DRV2510-Q1 with a single-ended source, apply either a voltage divider to bias IN- to 3 V, or use a 0.1- μ F cap from IN- to GND to have the device self bias. Apply the single-ended signal to the IN+ pin through an AC coupling capacitor.

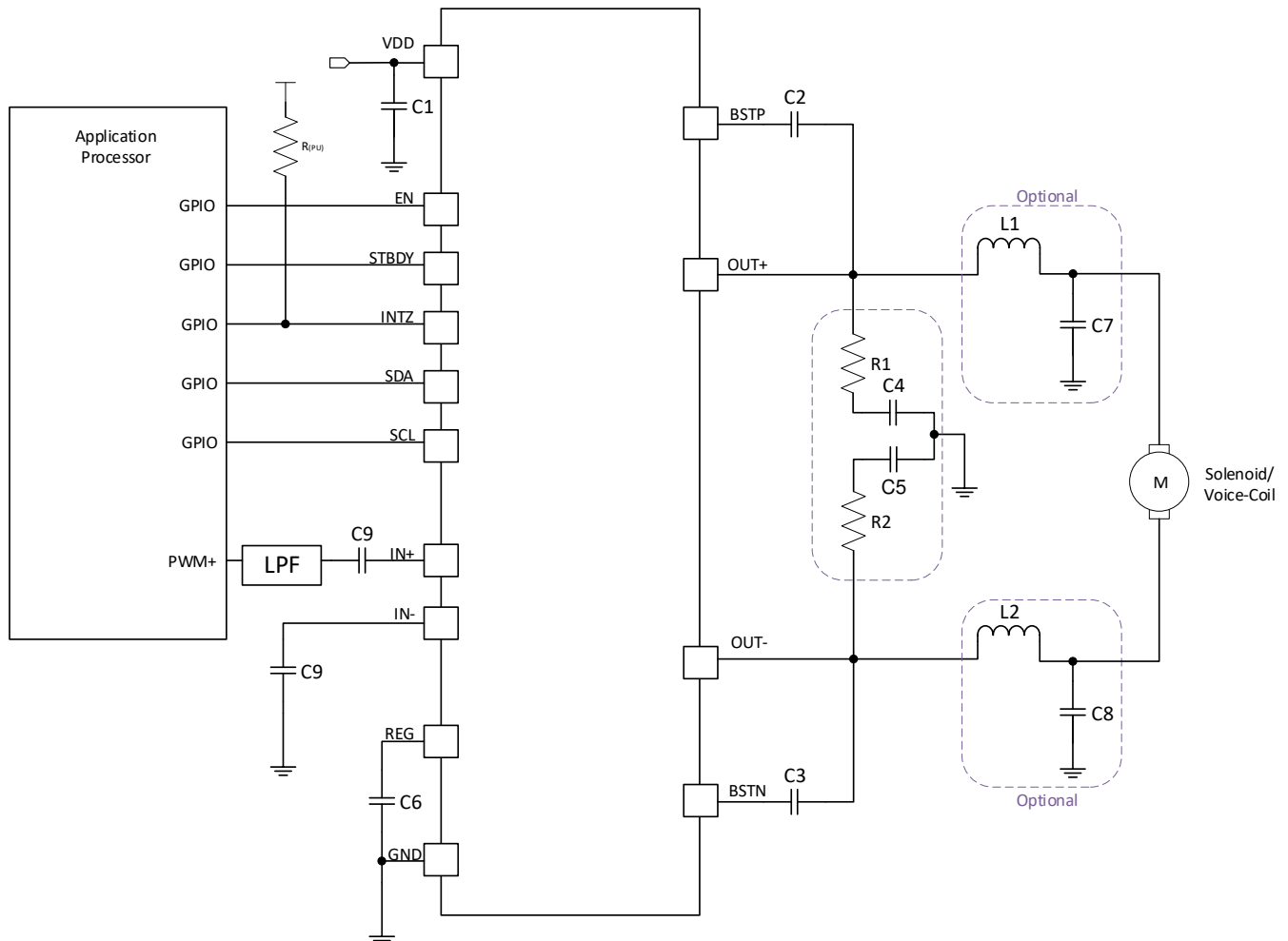

Figure 8-1. Typical Application Schematic

8.2.1.1 Design Requirements

For most applications the following component values found in [Table 8-1](#) below can be used.

Table 8-1. Component Requirements Table

COMPONENT	DESCRIPTION	SPECIFICATION	TYPICAL VALUE
C1	Supply capacitor	Capacitance	22 μF, 10 μF, and 0.1 μF
C2/C3	Boost capacitor	Capacitance	0.22 μF
C4/C5	Output snubber capacitor	Capacitance	470 pF
C6	Regulator capacitor	Capacitance	1 μF
C9	Input decoupling capacitor	Capacitance	0.1 μF
R1/R2	Output snubber resistor	Resistance	3.3 Ω
R _(PU)	Pull-up resistor	Resistance	100 kΩ

8.2.1.2 Detailed Design Procedure

8.2.1.2.1 Optional Components

Note that in the diagrams, there are a few optional external components. These optional external components may be needed in the application to meet EMI/EMC standards and specifications by filters necessary frequency spectrums.

8.2.1.2.2 Capacitor Selection

A bulk bypass capacitor should be mounted between VBAT and GND. The capacitance needs to be >22 uF with a X5R or better rating on the power pins to GND. Also include two ceramic capacitors in the ranges of 220 pF to 1 uF and 100 nF to 1 uF. The bootstrap capacitors, BSTP and BSTN, should be 220-nF ceramic capacitors of quality X5R or better rated for at least the maximum rating of the pin.

8.2.1.2.3 Solenoid Selection

The DRV2510-Q1 solenoid driver can accommodate a variety of solenoids. Solenoids should have an equivalent resistance of 1.6 Ω or greater. Solenoids with lower resistances are prone to driving high currents. A maximum peak current of 3-A should not be exceeded.

8.2.1.2.4 Output Filter Considerations

The output filter is optional and is mainly for limiting peak currents. A second-order Butterworth low-pass filter with the cut-off frequency set to a few kilohertz should be sufficient. See [Equation 1](#), through [Equation 4](#), for example filter design.

$$H(s) = \frac{1}{s^2 + \sqrt{2}s + 1} \quad (1)$$

$$L_x = \frac{\sqrt{2} \times R_L}{2\omega_0} \quad (2)$$

$$2 \times C_F = \frac{\sqrt{2}}{2 \times \frac{R_L}{2} \times \omega_0} \quad (3)$$

$$\omega_0 = 2\pi \times f \quad (4)$$

8.2.1.3 Application Curves

These application curves were taken using an HA200 solenoid with a 100-g mass, and the acceleration was measured using the DRV-AAC16-EVM accelerometer. The following scales apply to the graphs:

- Output Differential Voltage scale is shown on the plots at 5-V/div
- Acceleration scale is 5.85-G/div
- Current scale is 2-A/div

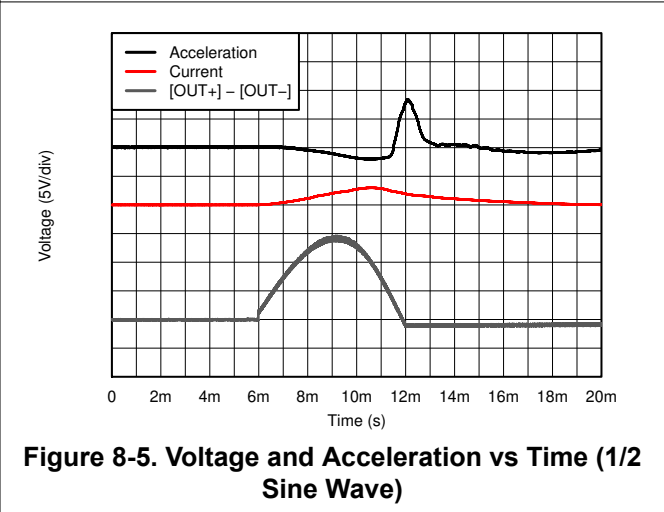
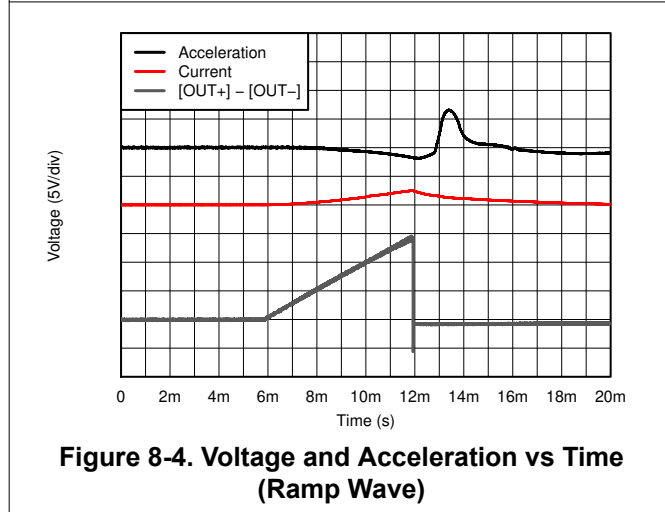
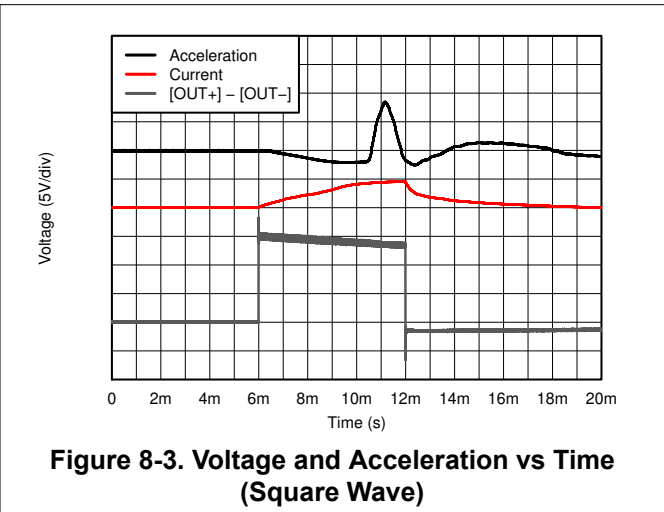
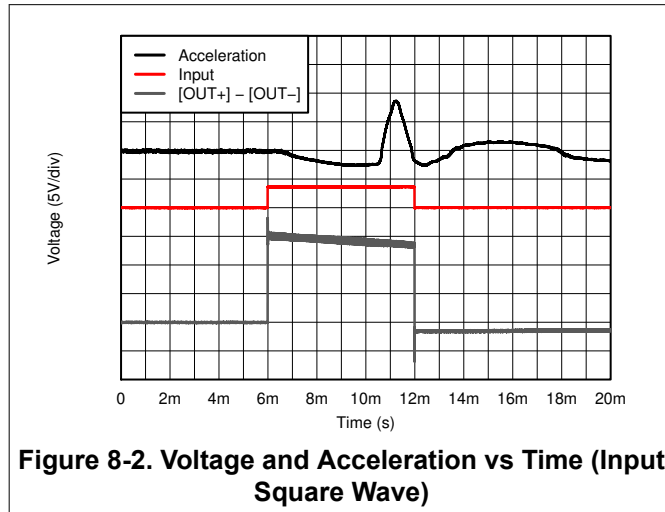

8.2.1.4 Differential Input Diagram

To use the DRV2510-Q1 with a differential input source, apply both inputs differentially through AC coupling capacitors from a control source (GPIO, DAC, etc...).

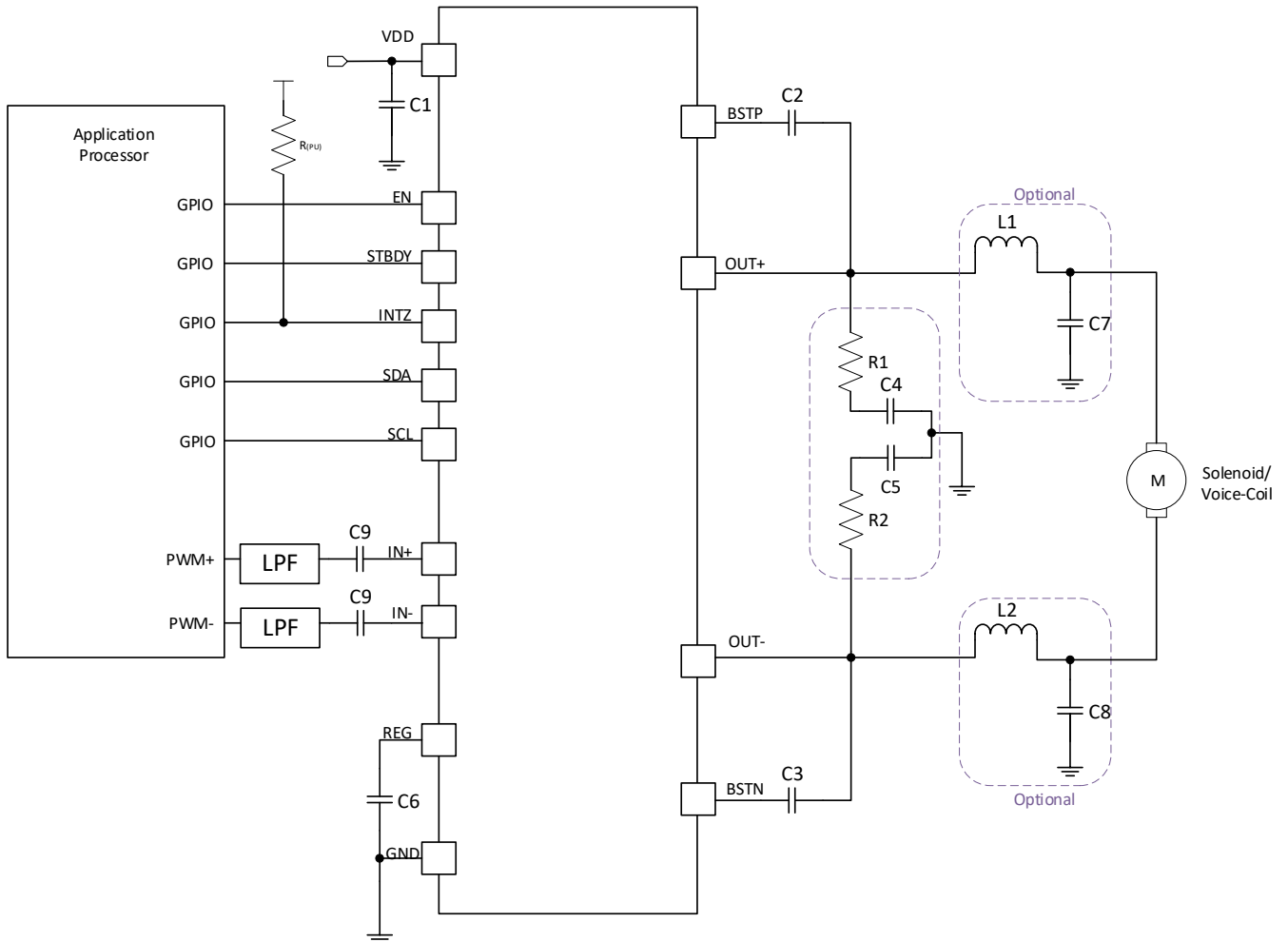

Figure 8-6. Typical Application Schematic

9 Power Supply Recommendations

The DRV2510-Q1 device operates from 4.5 V - 18 V and this supply should be able to handle high surge currents in order to meet the high current draws for haptics effects. Additionally the DRV2510-Q1 should have 22- μ F, 10- μ F and 0.1- μ F ceramic capacitors near the VDD pin for additional decoupling from trace routing.

10 Layout

10.1 Layout Guidelines

The EVM layout optimizes for thermal dissipation and EMC performance. The DRV2510-Q1 device has a thermal pad down, and good thermal conduction and dissipation require adequate copper area. Layout also affects EMC performance. It is best practice to use the same/similar layout as shown below in the DRV2510Q1EVM.

10.2 Layout Example

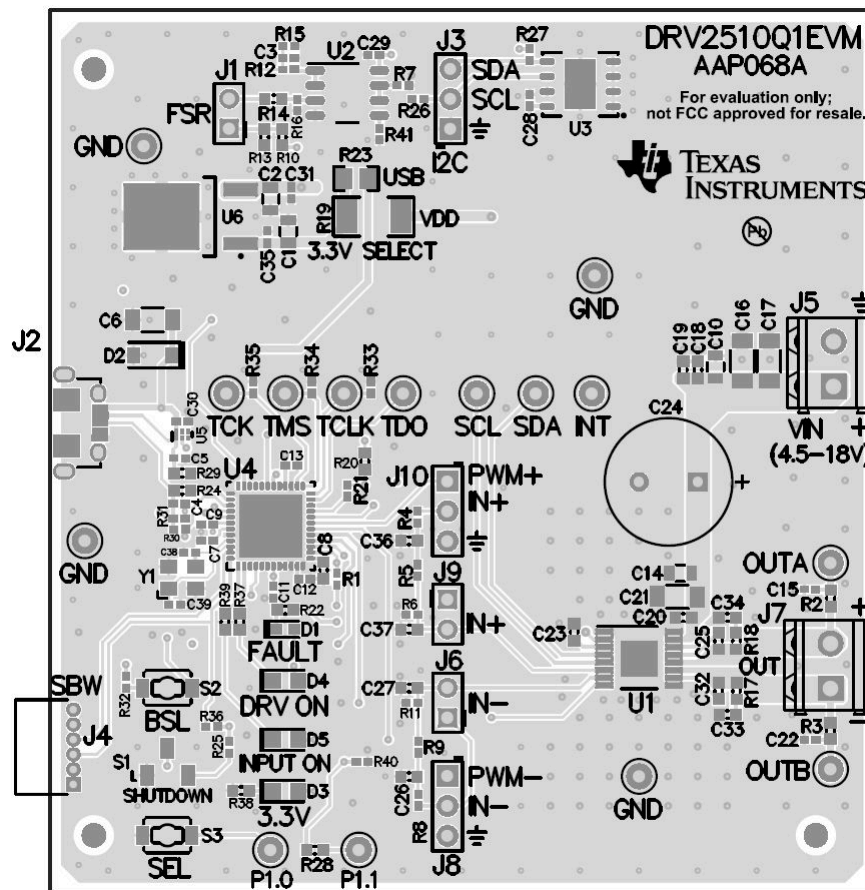

Figure 10-1. DRV2510-Q1 EVM

11 Device and Documentation Support

11.1 Device Support

11.1.1 Third-Party Products Disclaimer

TI'S PUBLICATION OF INFORMATION REGARDING THIRD-PARTY PRODUCTS OR SERVICES DOES NOT CONSTITUTE AN ENDORSEMENT REGARDING THE SUITABILITY OF SUCH PRODUCTS OR SERVICES OR A WARRANTY, REPRESENTATION OR ENDORSEMENT OF SUCH PRODUCTS OR SERVICES, EITHER ALONE OR IN COMBINATION WITH ANY TI PRODUCT OR SERVICE.

11.2 Receiving Notification of Documentation Updates

To receive notification of documentation updates, navigate to the device product folder on ti.com. Click on *Subscribe to updates* to register and receive a weekly digest of any product information that has changed. For change details, review the revision history included in any revised document.

11.3 Support Resources

[TI E2E™ support forums](#) are an engineer's go-to source for fast, verified answers and design help — straight from the experts. Search existing answers or ask your own question to get the quick design help you need.

Linked content is provided "AS IS" by the respective contributors. They do not constitute TI specifications and do not necessarily reflect TI's views; see TI's [Terms of Use](#).

11.4 Trademarks

SpeakerGuard™ and TI E2E™ are trademarks of Texas Instruments.
All trademarks are the property of their respective owners.

11.5 Electrostatic Discharge Caution



This integrated circuit can be damaged by ESD. Texas Instruments recommends that all integrated circuits be handled with appropriate precautions. Failure to observe proper handling and installation procedures can cause damage.

ESD damage can range from subtle performance degradation to complete device failure. Precision integrated circuits may be more susceptible to damage because very small parametric changes could cause the device not to meet its published specifications.

11.6 Glossary

[TI Glossary](#) This glossary lists and explains terms, acronyms, and definitions.

12 Mechanical, Packaging, and Orderable Information

The following pages include mechanical, packaging, and orderable information. This information is the most current data available for the designated devices. This data is subject to change without notice and revision of this document. For browser-based versions of this data sheet, refer to the left-hand navigation.

PACKAGING INFORMATION

Orderable Device	Status (1)	Package Type	Package Drawing	Pins	Package Qty	Eco Plan (2)	Lead finish/ Ball material (6)	MSL Peak Temp (3)	Op Temp (°C)	Device Marking (4/5)	Samples
DRV2510QPWPRQ1	ACTIVE	HTSSOP	PWP	16	2000	RoHS & Green	NIPDAU	Level-3-260C-168 HR	-40 to 125	DRV2510	Samples

(1) The marketing status values are defined as follows:

ACTIVE: Product device recommended for new designs.

LIFEBUY: TI has announced that the device will be discontinued, and a lifetime-buy period is in effect.

NRND: Not recommended for new designs. Device is in production to support existing customers, but TI does not recommend using this part in a new design.

PREVIEW: Device has been announced but is not in production. Samples may or may not be available.

OBSELETE: TI has discontinued the production of the device.

(2) **RoHS:** TI defines "RoHS" to mean semiconductor products that are compliant with the current EU RoHS requirements for all 10 RoHS substances, including the requirement that RoHS substance do not exceed 0.1% by weight in homogeneous materials. Where designed to be soldered at high temperatures, "RoHS" products are suitable for use in specified lead-free processes. TI may reference these types of products as "Pb-Free".

RoHS Exempt: TI defines "RoHS Exempt" to mean products that contain lead but are compliant with EU RoHS pursuant to a specific EU RoHS exemption.

Green: TI defines "Green" to mean the content of Chlorine (Cl) and Bromine (Br) based flame retardants meet JS709B low halogen requirements of <=1000ppm threshold. Antimony trioxide based flame retardants must also meet the <=1000ppm threshold requirement.

(3) MSL, Peak Temp. - The Moisture Sensitivity Level rating according to the JEDEC industry standard classifications, and peak solder temperature.

(4) There may be additional marking, which relates to the logo, the lot trace code information, or the environmental category on the device.

(5) Multiple Device Markings will be inside parentheses. Only one Device Marking contained in parentheses and separated by a "-" will appear on a device. If a line is indented then it is a continuation of the previous line and the two combined represent the entire Device Marking for that device.

(6) Lead finish/Ball material - Orderable Devices may have multiple material finish options. Finish options are separated by a vertical ruled line. Lead finish/Ball material values may wrap to two lines if the finish value exceeds the maximum column width.

Important Information and Disclaimer:The information provided on this page represents TI's knowledge and belief as of the date that it is provided. TI bases its knowledge and belief on information provided by third parties, and makes no representation or warranty as to the accuracy of such information. Efforts are underway to better integrate information from third parties. TI has taken and continues to take reasonable steps to provide representative and accurate information but may not have conducted destructive testing or chemical analysis on incoming materials and chemicals. TI and TI suppliers consider certain information to be proprietary, and thus CAS numbers and other limited information may not be available for release.

In no event shall TI's liability arising out of such information exceed the total purchase price of the TI part(s) at issue in this document sold by TI to Customer on an annual basis.

TAPE AND REEL INFORMATION

QUADRANT ASSIGNMENTS FOR PIN 1 ORIENTATION IN TAPE

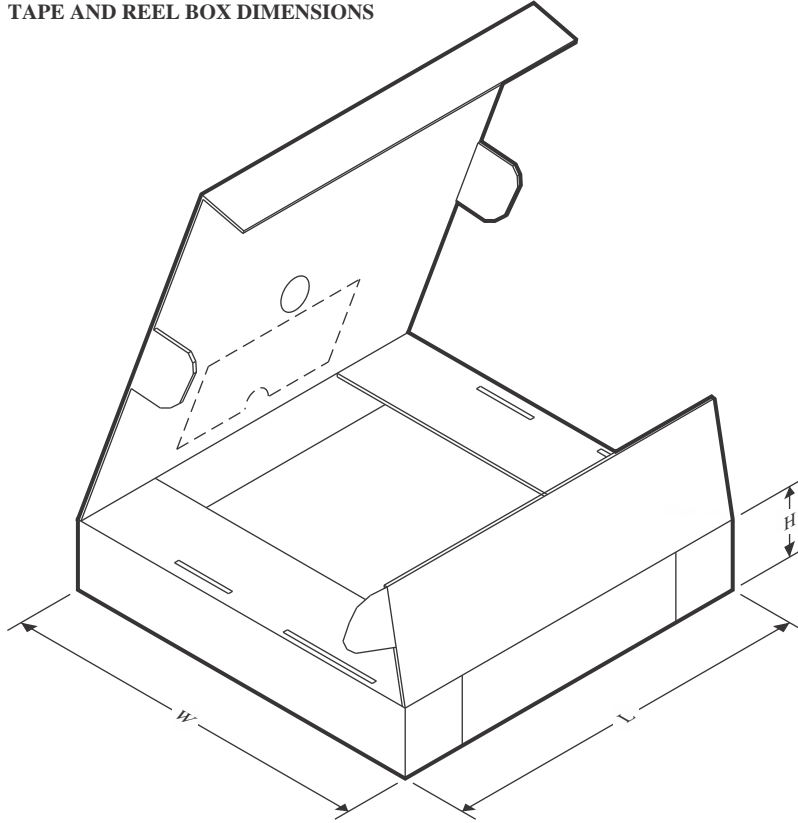

*All dimensions are nominal

Device	Package Type	Package Drawing	Pins	SPQ	Reel Diameter (mm)	Reel Width W1 (mm)	A0 (mm)	B0 (mm)	K0 (mm)	P1 (mm)	W (mm)	Pin1 Quadrant
DRV2510QPWRQ1	HTSSOP	PWP	16	2000	330.0	12.4	6.9	5.6	1.6	8.0	12.0	Q1

TAPE AND REEL BOX DIMENSIONS

*All dimensions are nominal

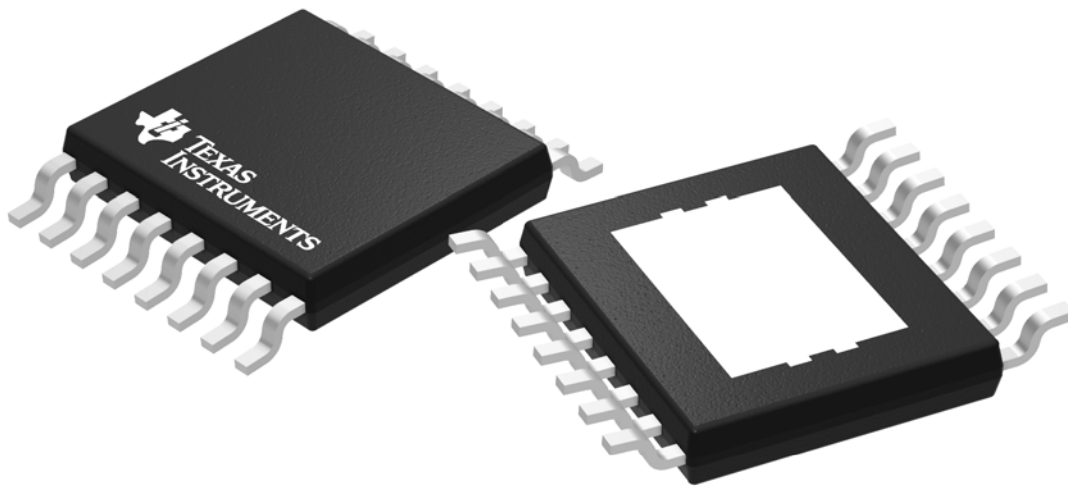
Device	Package Type	Package Drawing	Pins	SPQ	Length (mm)	Width (mm)	Height (mm)
DRV2510QPWPRQ1	HTSSOP	PWP	16	2000	350.0	350.0	43.0



Images above are just a representation of the package family, actual package may vary.
Refer to the product data sheet for package details.

PWP0016B



PACKAGE OUTLINE

PowerPAD™ TSSOP - 1.2 mm max height

PLASTIC SMALL OUTLINE

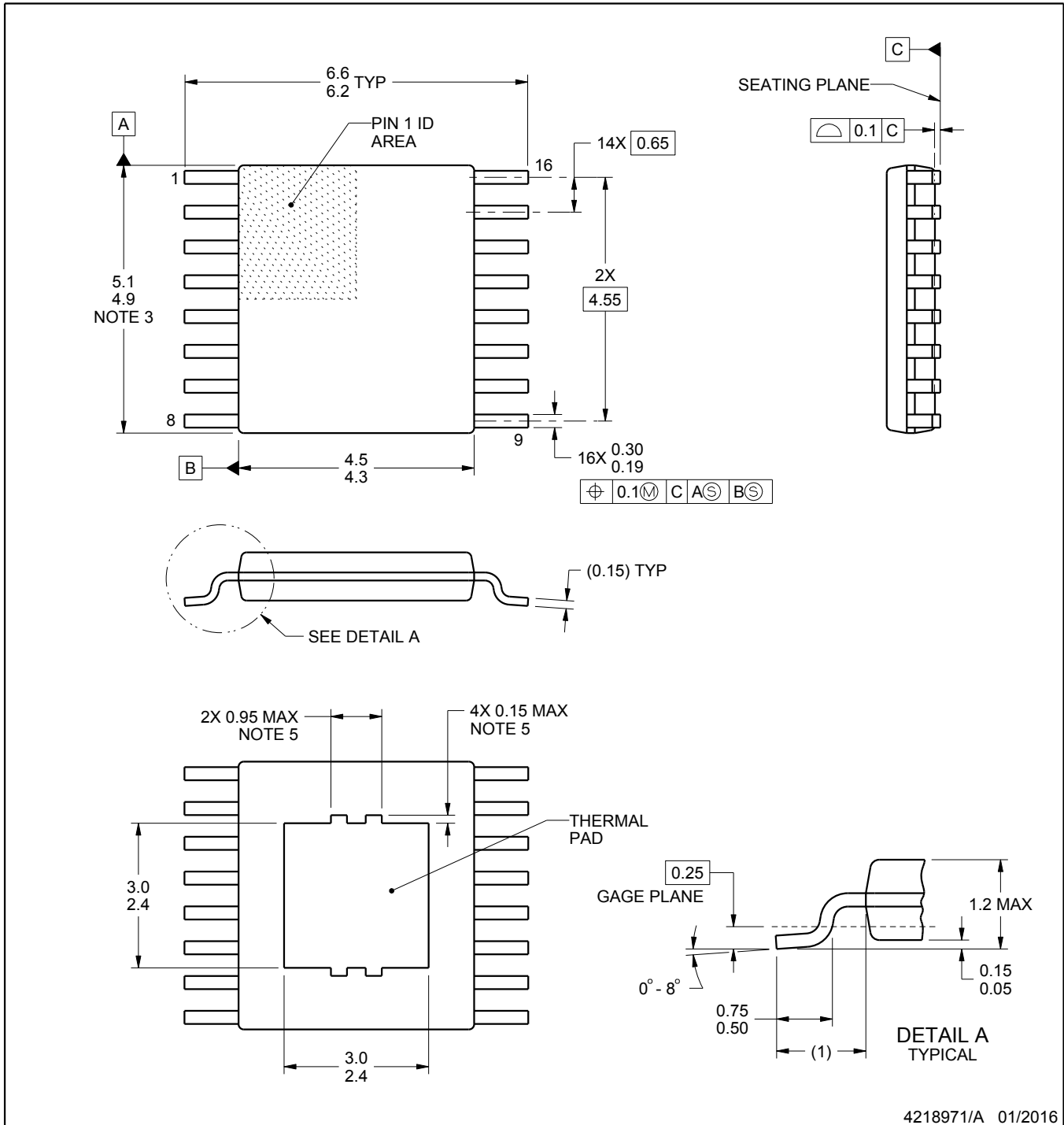

NOTES:

PowerPAD is a trademark of Texas Instruments.

1. All linear dimensions are in millimeters. Any dimensions in parenthesis are for reference only. Dimensioning and tolerancing per ASME Y14.5M.
2. This drawing is subject to change without notice.
3. This dimension does not include mold flash, protrusions, or gate burrs. Mold flash, protrusions, or gate burrs shall not exceed 0.15 mm per side.
4. Reference JEDEC registration MO-153.
5. Features may not be present.

EXAMPLE BOARD LAYOUT

PWP0016B

PowerPAD™ TSSOP - 1.2 mm max height

PLASTIC SMALL OUTLINE

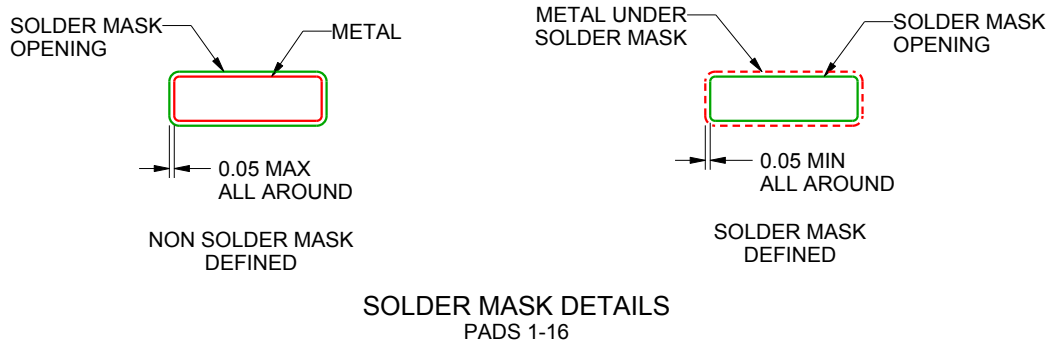
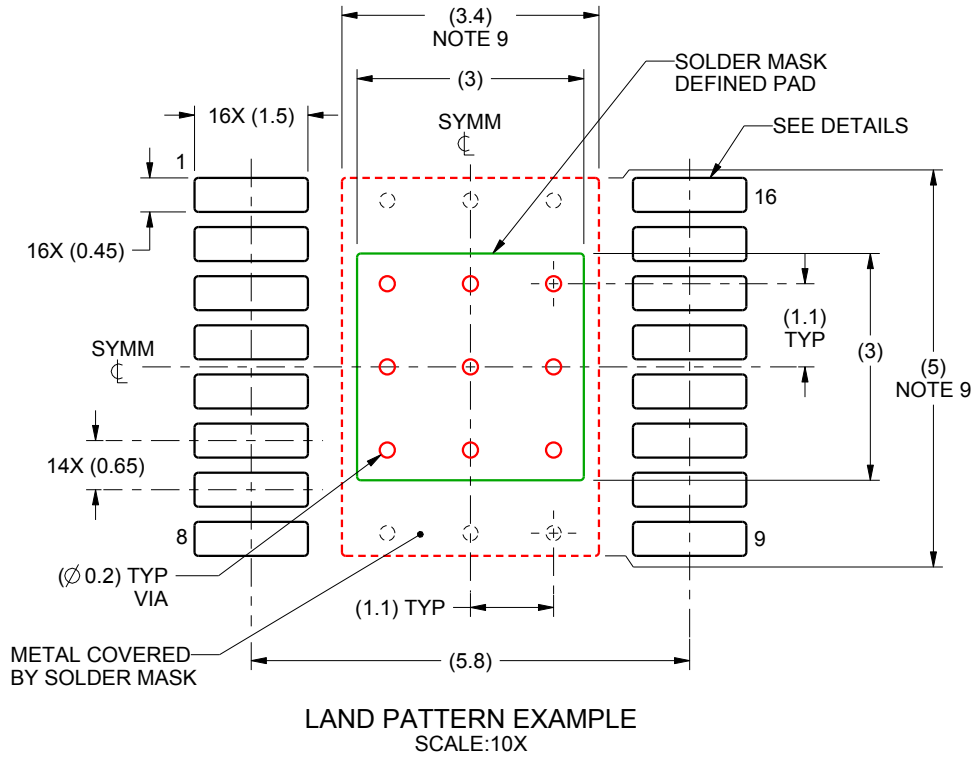

4218971/A 01/2016

NOTES: (continued)

6. Publication IPC-7351 may have alternate designs.
7. Solder mask tolerances between and around signal pads can vary based on board fabrication site.
8. This package is designed to be soldered to a thermal pad on the board. For more information, see Texas Instruments literature numbers SLMA002 (www.ti.com/lit/slma002) and SLMA004 (www.ti.com/lit/slma004).
9. Size of metal pad may vary due to creepage requirement.

EXAMPLE STENCIL DESIGN

PWP0016B

PowerPAD™ TSSOP - 1.2 mm max height

PLASTIC SMALL OUTLINE

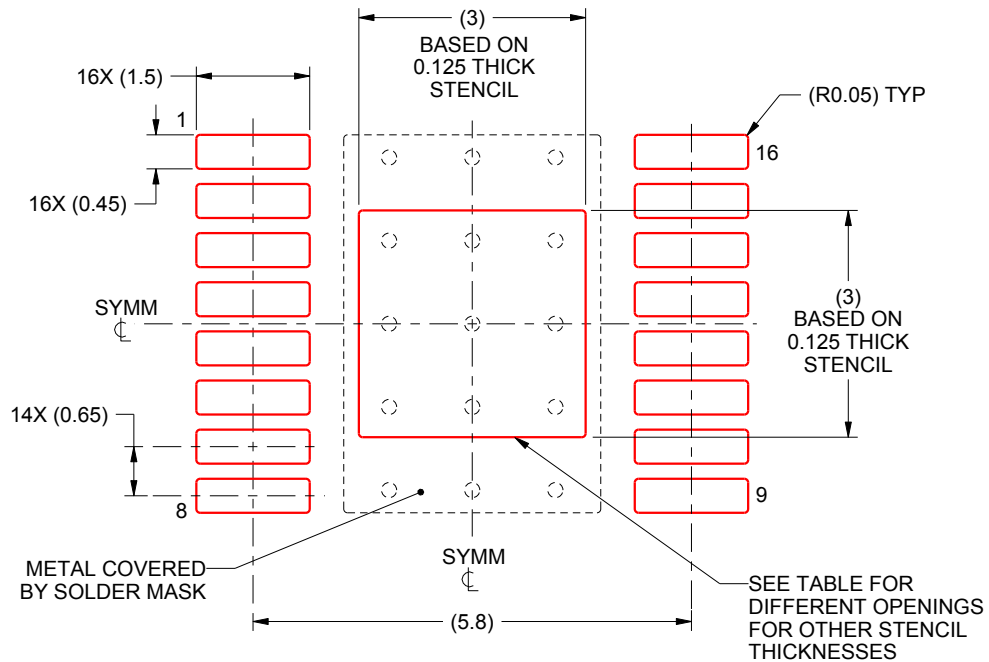

SOLDER PASTE EXAMPLE
 EXPOSED PAD
 100% PRINTED SOLDER COVERAGE BY AREA
 SCALE:10X

STENCIL THICKNESS	SOLDER STENCIL OPENING
0.1	3.35 X 3.35
0.125	3 X 3 (SHOWN)
0.15	2.74 X 2.74
0.175	2.54 X 2.54

4218971/A 01/2016

NOTES: (continued)

- 10. Laser cutting apertures with trapezoidal walls and rounded corners may offer better paste release. IPC-7525 may have alternate design recommendations.
- 11. Board assembly site may have different recommendations for stencil design.

IMPORTANT NOTICE AND DISCLAIMER

TI PROVIDES TECHNICAL AND RELIABILITY DATA (INCLUDING DATA SHEETS), DESIGN RESOURCES (INCLUDING REFERENCE DESIGNS), APPLICATION OR OTHER DESIGN ADVICE, WEB TOOLS, SAFETY INFORMATION, AND OTHER RESOURCES "AS IS" AND WITH ALL FAULTS, AND DISCLAIMS ALL WARRANTIES, EXPRESS AND IMPLIED, INCLUDING WITHOUT LIMITATION ANY IMPLIED WARRANTIES OF MERCHANTABILITY, FITNESS FOR A PARTICULAR PURPOSE OR NON-INFRINGEMENT OF THIRD PARTY INTELLECTUAL PROPERTY RIGHTS.

These resources are intended for skilled developers designing with TI products. You are solely responsible for (1) selecting the appropriate TI products for your application, (2) designing, validating and testing your application, and (3) ensuring your application meets applicable standards, and any other safety, security, regulatory or other requirements.

These resources are subject to change without notice. TI grants you permission to use these resources only for development of an application that uses the TI products described in the resource. Other reproduction and display of these resources is prohibited. No license is granted to any other TI intellectual property right or to any third party intellectual property right. TI disclaims responsibility for, and you will fully indemnify TI and its representatives against, any claims, damages, costs, losses, and liabilities arising out of your use of these resources.

TI's products are provided subject to [TI's Terms of Sale](#) or other applicable terms available either on [ti.com](https://www.ti.com) or provided in conjunction with such TI products. TI's provision of these resources does not expand or otherwise alter TI's applicable warranties or warranty disclaimers for TI products.

TI objects to and rejects any additional or different terms you may have proposed.

Mailing Address: Texas Instruments, Post Office Box 655303, Dallas, Texas 75265
Copyright © 2023, Texas Instruments Incorporated