

INAx191 40-V, Bidirectional, Ultra-Precise Current Sense Amplifier With picoamp IB and ENABLE in WCSP Package

1 Features

- Low power:
 - Supply voltage, V_S : 1.7 V to 5.5 V
 - Shutdown current: 100 nA (max INA191)
 - Quiescent current: 43 μ A at 25 °C (INA191)
- Low input bias currents: 100 pA (typical) (enables microamp current measurement)
- Bidirectional current measurement (INA2191)
- Accuracy:
 - $\pm 0.25\%$ max gain error (A2 to A5 devices)
 - 7-ppm/°C gain drift (maximum)
 - ± 12 μ V (maximum) offset voltage
 - 0.13- μ V/°C offset drift (maximum)
- Wide common-mode voltage: -0.2 V to +40 V
- Gain options:
 - INAx191A1: 25 V/V
 - INAx191A2: 50 V/V
 - INAx191A3: 100 V/V
 - INAx191A4: 200 V/V
 - INAx191A5: 500 V/V
- Packages:
 - INA191: 0.895-mm² DSBGA
 - INA2191: 1.79-mm² DSBGA

2 Applications

- Notebook computers
- Cell phones
- Battery-powered devices
- Telecom equipment
- Power management
- Battery chargers

3 Description

The INAx191 is a low-power, voltage-output, current-shunt monitor (also called a current-sense amplifier) that is commonly used for overcurrent protection, precision-current measurement for system optimization, or in closed-loop feedback circuits. This device can sense drops across shunts at common-mode voltages from -0.2 V to +40 V, independent of the supply voltage. The low input bias current of the INAx191 permits the use of larger current-sense resistors, and thus provides accurate current measurements in the μ A range. Five fixed gains are available: 25 V/V, 50 V/V, 100 V/V, 200 V/V, or 500 V/V. The low offset voltage of the zero-drift architecture extends the dynamic range of the current measurement, and allows for smaller sense resistors with lower power loss while still providing accurate current measurements.

The INA191 operates from a single 1.7-V to 5.5-V power supply, drawing a maximum of 65 μ A of supply current when enabled and only 100 nA when disabled. The device is specified over the operating temperature range of -40 °C to +125 °C, and offered in a DSBGA-6 (INA191) and DSBGA-12 (INA2191) packages.

Device Information⁽¹⁾

PART NUMBER	PACKAGE	BODY SIZE (NOM)
INA191	DSBGA (6)	1.17 mm × 0.765 mm
INA2191	DSBGA (12)	1.17 mm × 1.53 mm

(1) For all available packages, see the package option addendum at the end of the data sheet.

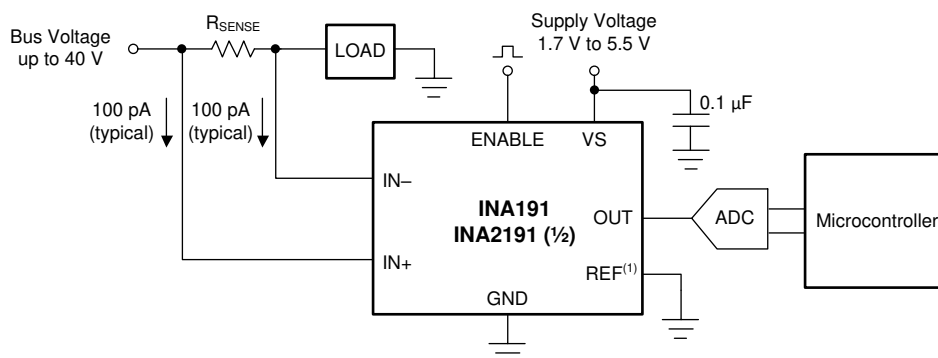

(1) REF pin only available on INA2191

Simplified Schematic



Table of Contents

1 Features	1	8 Application and Implementation	22
2 Applications	1	8.1 Application Information.....	22
3 Description	1	8.2 Typical Application.....	27
4 Revision History	2	9 Power Supply Recommendations	28
5 Pin Configuration and Functions	3	10 Layout	29
6 Specifications	5	10.1 Layout Guidelines.....	29
6.1 Absolute Maximum Ratings	5	10.2 Layout Examples.....	29
6.2 ESD Ratings	5	11 Device and Documentation Support	31
6.3 Recommended Operating Conditions	5	11.1 Documentation Support.....	31
6.4 Thermal Information	5	11.2 Receiving Notification of Documentation Updates..	31
6.5 Electrical Characteristics	6	11.3 Support Resources.....	31
6.6 Typical Characteristics.....	8	11.4 Trademarks.....	31
7 Detailed Description	15	11.5 Electrostatic Discharge Caution.....	31
7.1 Overview.....	15	11.6 Glossary.....	31
7.2 Functional Block Diagram.....	15	12 Mechanical, Packaging, and Orderable	
7.3 Feature Description.....	16	Information	31
7.4 Device Functional Modes.....	18		

4 Revision History

Changes from Revision B (February 2021) to Revision C (August 2021)	Page
• Changed data sheet status from Production Mixed to Production Data.....	1
• Changed INA2191 device status from Advanced Information to Production Data	1
• Added INA191 and INA2191 test conditions to gain error, gain error drift, swing to V_S , and enable logic parameters.....	6
• Changed INA191 and INA2191 test conditions for output leakage disabled parameters.....	6
• Changed INA2191 values for the quiescent current parameters for production data.....	6
• Changed the <i>Typical Characteristics</i> section.....	8
• Changed INA2191 information in the <i>Low Quiescent Current With Output Enable</i> section.....	16
• Changed INA2191 information in the <i>Unidirectional Mode</i> section.....	18
• Changed Figure 8-3 and the filtering information in the <i>Signal Conditioning</i> section.....	24

Changes from Revision A (April 2019) to Revision B (February 2021)	Page
• Changed data sheet status from Production Data to Production Mixed.....	1
• Added Advanced Information INA2191 device to the data sheet.....	1

Changes from Revision * (February 2019) to Revision A (April 2019)	Page
• Changed device from advanced information to production data (active).....	1

5 Pin Configuration and Functions

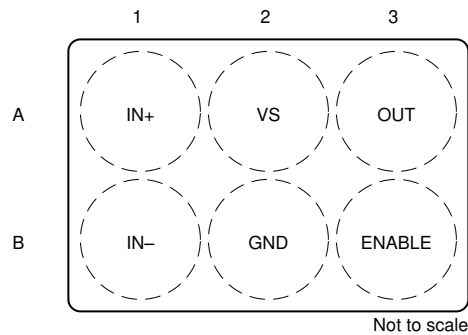

Figure 5-1. INA191 YFD Package 6-Pin DSBGA Top View

Table 5-1. Pin Functions (INA191)

PIN		TYPE	DESCRIPTION
NAME	NO.		
ENABLE	B3	Digital input	Enable pin. When this pin is driven to V_S , the device is on and functions as a current sense amplifier. When this pin is driven to GND, the device is off, the supply current is reduced, and the output is placed in a high-impedance state. This pin must be driven externally, or connected to V_S if not used.
GND	B2	Analog	Ground.
IN+	A1	Analog input	Current-shunt monitor positive input. For high-side applications, connect this pin to the bus voltage side of the sense resistor. For low-side applications, connect this pin to the load side of the sense resistor.
IN-	B1	Analog input	Current-shunt monitor negative input. For high-side applications, connect this pin to the load side of the sense resistor. For low-side applications, connect this pin to the ground side of the sense resistor.
OUT	A3	Analog output	This pin provides an analog voltage output that is the amplified voltage difference from the IN+ to the IN- pins.
VS	A2	Analog	Power supply, 1.7 V to 5.5 V.

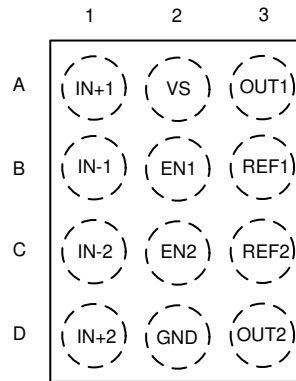

Figure 5-2. INA2191 YBJ Package 12-Pin DSBGA Top View

Table 5-2. Pin Functions (INA2191)

PIN		TYPE	DESCRIPTION
NAME	NO.		
ENABLE1	B2	Digital input	Enable pin for output 1. When this pin is driven to V_S , channel 1 is on and functions as a current sense amplifier. When both enable pins are driven to GND, the device is off and the supply current is reduced. This pin must be driven externally, or connected to V_S if not used.
ENABLE2	C2	Digital input	Enable pin for output 2. When this pin is driven to V_S , channel 2 is on and functions as a current sense amplifier. When both enable pins are driven to GND, the device is off and the supply current is reduced. This pin must be driven externally, or connected to V_S if not used.
GND	D2	Analog	Ground.
IN+1	A1	Analog input	Current-shunt monitor positive input for channel 1. For high-side applications, connect this pin to the bus voltage side of the sense resistor. For low-side applications, connect this pin to the load side of the sense resistor.
IN+2	D1	Analog input	Current-shunt monitor positive input for channel 2. For high-side applications, connect this pin to the bus voltage side of the sense resistor. For low-side applications, connect this pin to the load side of the sense resistor.
IN-1	B1	Analog input	Current-shunt monitor negative input for channel 1. For high-side applications, connect this pin to the load side of the sense resistor. For low-side applications, connect this pin to the ground side of the sense resistor.
IN-2	C1	Analog input	Current-shunt monitor negative input for channel 2. For high-side applications, connect this pin to the load side of the sense resistor. For low-side applications, connect this pin to the ground side of the sense resistor.
OUT1	A3	Analog output	This pin provides an analog voltage output that is the amplified voltage difference from the IN+1 to the IN-1 pins, and is offset by the voltage applied to the REF1 pin.
OUT2	D3	Analog output	This pin provides an analog voltage output that is the amplified voltage difference from the IN+2 to the IN-2 pins, and is offset by the voltage applied to the REF2 pin.
REF1	B3	Analog input	Reference input for channel 1. Enables bidirectional current sensing for channel 1 with an externally applied voltage.
REF2	C3	Analog input	Reference input for channel 2. Enables bidirectional current sensing for channel 2 with an externally applied voltage.
VS	A2	Analog	Power supply, 1.7 V to 5.5 V.

6 Specifications

6.1 Absolute Maximum Ratings

over operating free-air temperature range (unless otherwise noted)⁽¹⁾

		MIN	MAX	UNIT	
V _S	Supply voltage		6	V	
V _{IN+} , V _{IN-}	Analog inputs	Differential (V _{IN+}) – (V _{IN-}) ⁽²⁾	–42	42	V
		V _{IN+} , V _{IN-} , with respect to GND ⁽³⁾	GND – 0.3	42	
V _{ENABLE}	ENABLE	GND – 0.3	6	V	
	REF, OUT ⁽³⁾	GND – 0.3	(V _S) + 0.3	V	
	Input current into any pin ⁽³⁾		5	mA	
T _A	Operating temperature	–55	150	°C	
T _J	Junction temperature		150	°C	
T _{stg}	Storage temperature	–65	150	°C	

- (1) Stresses beyond those listed under *Absolute Maximum Ratings* may cause permanent damage to the device. These are stress ratings only, which do not imply functional operation of the device at these or any other conditions beyond those indicated under *Recommended Operating Conditions*. Exposure to absolute-maximum-rated conditions for extended periods may affect device reliability.
- (2) V_{IN+} and V_{IN-} are the voltages at the IN+ and IN– pins, respectively.
- (3) Input voltage at any pin may exceed the voltage shown if the current at that pin is limited to 5 mA.

6.2 ESD Ratings

			VALUE	UNIT
V _(ESD)	Electrostatic discharge	Human-body model (HBM), per ANSI/ESDA/JEDEC JS-001 ⁽¹⁾	±2000	V
		Charged-device model (CDM), per JEDEC specification JESD22-C101 ⁽²⁾	±1000	

- (1) JEDEC document JEP155 states that 500-V HBM allows safe manufacturing with a standard ESD control process.
- (2) JEDEC document JEP157 states that 250-V CDM allows safe manufacturing with a standard ESD control process.

6.3 Recommended Operating Conditions

over operating free-air temperature range (unless otherwise noted)

		MIN	NOM	MAX	UNIT
V _{CM}	Common-mode input range	– 0.2		40	V
V _{IN+} , V _{IN-}	Input pin voltage range	– 0.2		40	V
V _S	Operating supply voltage	1.7		5.5	V
V _{REF}	Reference pin voltage range	0		V _S	V
T _A	Operating free-air temperature	–40		125	°C

6.4 Thermal Information

THERMAL METRIC ⁽¹⁾		INA191	INA2191	UNIT
		YFD (DSBGA)	YBJ (DSBGA)	
		6 PINS	12 PINS	
R _{θJA}	Junction-to-ambient thermal resistance	141.4	94.1	°C/W
R _{θJC(top)}	Junction-to-case (top) thermal resistance	1.1	0.6	°C/W
R _{θJB}	Junction-to-board thermal resistance	45.7	23.8	°C/W
Ψ _{JT}	Junction-to-top characterization parameter	0.4	0.3	°C/W
Ψ _{JB}	Junction-to-board characterization parameter	45.3	23.8	°C/W
R _{θJC(bot)}	Junction-to-case (bottom) thermal resistance	N/A	N/A	°C/W

- (1) For more information about traditional and new thermal metrics, see the [Semiconductor and IC Package Thermal Metrics](#) application report.

6.5 Electrical Characteristics

at $T_A = 25^\circ\text{C}$, $V_{\text{SENSE}} = V_{\text{IN}+} - V_{\text{IN}-}$, $V_S = 1.8\text{ V to } 5.0\text{ V}$, $V_{\text{IN}+} = 12\text{ V}$, $V_{\text{REF}} = V_S / 2$ (INA2191), and $V_{\text{ENABLE}} = V_S$ (unless otherwise noted)

PARAMETER		CONDITIONS	MIN	TYP	MAX	UNIT
INPUT						
CMRR	Common-mode rejection ratio, RTI ⁽¹⁾	$V_{\text{IN}+} = -0.1\text{ V to } 40\text{ V}$, $T_A = -40^\circ\text{C to } +125^\circ\text{C}$	132	150		dB
V_{OS}	Offset voltage, RTI ⁽¹⁾	$V_S = 1.8\text{ V}$		-2.5	± 12	μV
dV_{OS}/dT	Offset drift, RTI	$T_A = -40^\circ\text{C to } +125^\circ\text{C}$		10	130	$\text{nV}/^\circ\text{C}$
PSRR	Power-supply rejection ratio, RTI	$V_S = 1.7\text{ V to } 5.5\text{ V}$		-1	± 5	$\mu\text{V}/\text{V}$
I_{IB}	Input bias current	$V_{\text{SENSE}} = 0\text{ mV}$		0.1	3	nA
I_{IO}	Input offset current	$V_{\text{SENSE}} = 0\text{ mV}$		± 0.07		nA
OUTPUT						
G	Gain	A1 devices		25		V/V
		A2 devices		50		
		A3 devices		100		
		A4 devices		200		
		A5 devices		500		
E_G	Gain error	$V_{\text{OUT}} = 0.1\text{ V to } V_S - 0.1\text{ V}$	A1 devices, INA191	-0.17%	$\pm 0.35\%$	
			A1 devices, INA2191	+0.05%	$\pm 0.25\%$	
			A2, A3, A4, A5 devices	-0.04%	$\pm 0.25\%$	
	Gain error drift	$T_A = -40^\circ\text{C to } +125^\circ\text{C}$		2	7	$\text{ppm}/^\circ\text{C}$
	Nonlinearity error	$V_{\text{OUT}} = 0.1\text{ V to } V_S - 0.1\text{ V}$		$\pm 0.01\%$		
RVRR	Reference voltage rejection ratio	INA2191 only, $V_{\text{REF}} = 100\text{ mV to } V_S - 100\text{ mV}$, $T_A = -40^\circ\text{C to } +125^\circ\text{C}$	A1 devices	± 2	± 12	$\mu\text{V}/\text{V}$
			A2 devices	± 1	± 6	
			A3 devices	± 0.5	± 4	
			A4, A5 devices	± 0.25	± 3	
	Maximum capacitive load	No sustained oscillation		1		nF
VOLTAGE OUTPUT						
V_{SP}	Swing to V_S power-supply rail	$V_S = 1.8\text{ V}$, $R_L = 10\text{ k}\Omega$ to GND, $T_A = -40^\circ\text{C to } +125^\circ\text{C}$		$(V_S) - 23$	$(V_S) - 40$	mV
V_{SN}	Swing to GND	$V_S = 1.8\text{ V}$, $R_L = 10\text{ k}\Omega$ to GND, $T_A = -40^\circ\text{C to } +125^\circ\text{C}$, $V_{\text{SENSE}} = -10\text{ mV}$, $V_{\text{REF}} = 0\text{ V}$ (INA2191)		$(V_{\text{GND}}) + 0.05$	$(V_{\text{GND}}) + 1$	mV
V_{ZL}	Zero current output voltage	$V_S = 1.8\text{ V}$, $R_L = 10\text{ k}\Omega$ to GND, $T_A = -40^\circ\text{C to } +125^\circ\text{C}$, $V_{\text{SENSE}} = 0\text{ mV}$, for INA2191 $V_{\text{REF}} = 0\text{ V}$	A1, A2, A3 devices	$(V_{\text{GND}}) + 1$	$(V_{\text{GND}}) + 3$	mV
			A4 devices	$(V_{\text{GND}}) + 2$	$(V_{\text{GND}}) + 4$	mV
			A5 devices	$(V_{\text{GND}}) + 3$	$(V_{\text{GND}}) + 7$	mV
FREQUENCY RESPONSE						
BW	Bandwidth	$C_{\text{LOAD}} = 10\text{ pF}$	A1 devices	45		kHz
			A2 devices	37		
			A3 devices	35		
			A4 devices	33		
			A5 devices	27		
SR	Slew rate	$V_S = 5.0\text{ V}$, $V_{\text{OUT}} = 0.5\text{ V to } 4.5\text{ V}$		0.3		$\text{V}/\mu\text{s}$
t_s	Settling time	From current step to within 1% of final value		30		μs

at $T_A = 25^\circ\text{C}$, $V_{\text{SENSE}} = V_{\text{IN}+} - V_{\text{IN}-}$, $V_S = 1.8\text{ V to } 5.0\text{ V}$, $V_{\text{IN}+} = 12\text{ V}$, $V_{\text{REF}} = V_S / 2$ (INA2191), and $V_{\text{ENABLE}} = V_S$ (unless otherwise noted)

PARAMETER	CONDITIONS	MIN	TYP	MAX	UNIT
NOISE, RTI⁽¹⁾					
	Voltage noise density		75		nV/ $\sqrt{\text{Hz}}$
ENABLE					
I_{EN}	Leakage input current	$0\text{ V} \leq V_{\text{ENABLE}} \leq V_S$	1	100	nA
V_{IH}	High-level input voltage	$T_A = -40^\circ\text{C to } +125^\circ\text{C}$	1.35	5.5	V
V_{IL}	Low-level input voltage	$T_A = -40^\circ\text{C to } +125^\circ\text{C}$	0	0.4	V
V_{HYS}	Hysteresis		100		mV
I_{ODIS}	Output leakage disabled	$V_S = 1.8\text{ V}$, $V_{\text{OUT}} = 0\text{ V to } 1.8\text{ V}$, $V_{\text{ENABLE}} = 0\text{ V}$	1	5	μA
	Output leakage disabled (INA2191)	$V_S = 5\text{ V}$, $V_{\text{OUT}} = 0\text{ V to } 5.0\text{ V}$, $V_{\text{ENABLE}} = 0\text{ V}$	1	5	μA
POWER SUPPLY					
I_{Q}	Quiescent current (INA191)	$V_S = 1.8\text{ V}$, $V_{\text{SENSE}} = 0\text{ mV}$	43	65	μA
		$V_S = 1.8\text{ V}$, $V_{\text{SENSE}} = 0\text{ mV}$, $T_A = -40^\circ\text{C to } +125^\circ\text{C}$		85	μA
	Quiescent current (INA2191)	$V_S = 1.8\text{ V}$, $V_{\text{SENSE}} = 0\text{ mV}$ (Dual Channel)	96	130	μA
		$V_S = 1.8\text{ V}$, $V_{\text{SENSE}} = 0\text{ mV}$, $T_A = -40^\circ\text{C to } +125^\circ\text{C}$		180	μA
I_{QDIS}	Quiescent current disabled (INA191)	$V_{\text{ENABLE}} < 0.4\text{ V}$, $V_{\text{SENSE}} = 0\text{ mV}$ (Single Channel)	10	100	nA
I_{QDIS}	Quiescent current disabled (INA2191)	$V_{\text{ENABLE}1} < 0.4\text{ V}$, $V_{\text{ENABLE}2} < 0.4\text{ V}$, $V_{\text{SENSE}} = 0\text{ mV}$	20	200	nA

(1) RTI = referred-to-input.

6.6 Typical Characteristics

at $T_A = 25\text{ }^\circ\text{C}$, $V_S = 1.8\text{ V}$, $V_{IN+} = 12\text{ V}$, $V_{ENABLE} = V_S$, $V_{REF} = \text{GND}$ and all gain options (unless otherwise noted)

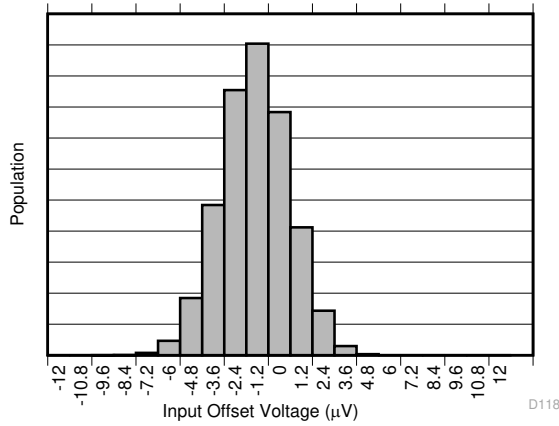

Figure 6-1. Input Offset Voltage Production Distribution

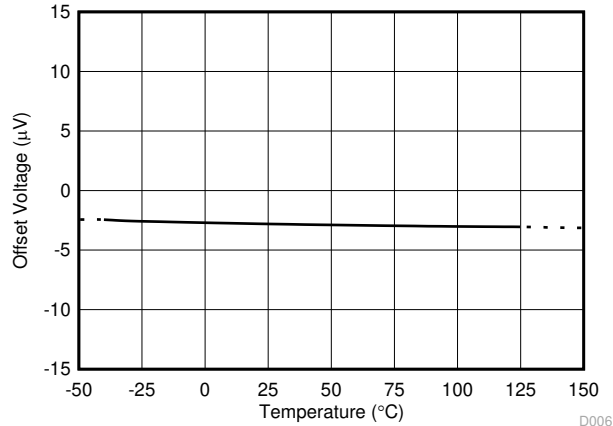

Figure 6-2. Offset Voltage vs. Temperature

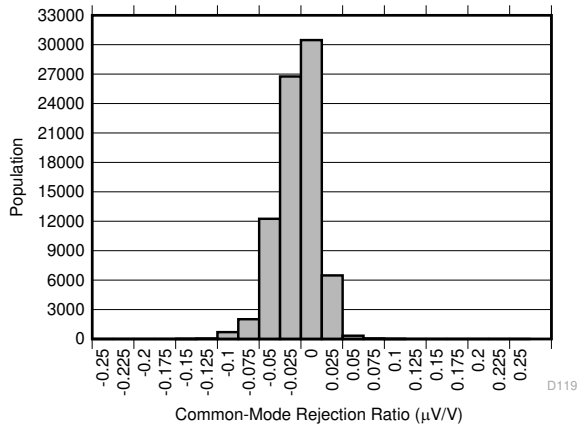

Figure 6-3. Common-Mode Rejection Production Distribution

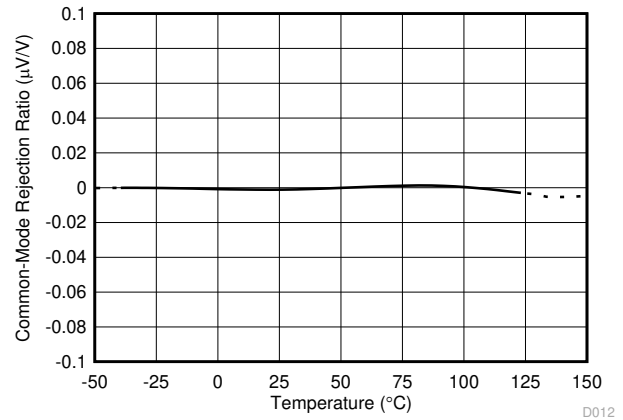

Figure 6-4. Common-Mode Rejection Ratio vs. Temperature

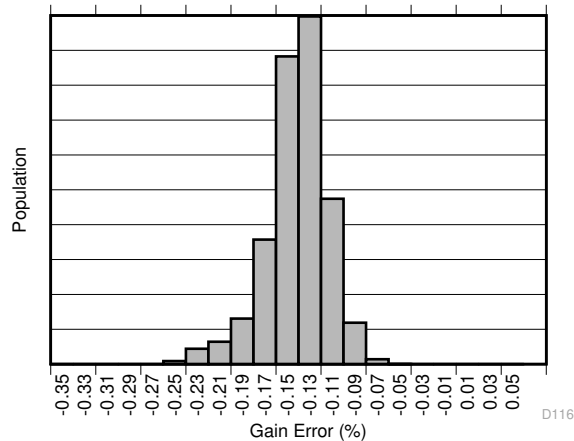

Figure 6-5. Gain Error Production Distribution (INA191)

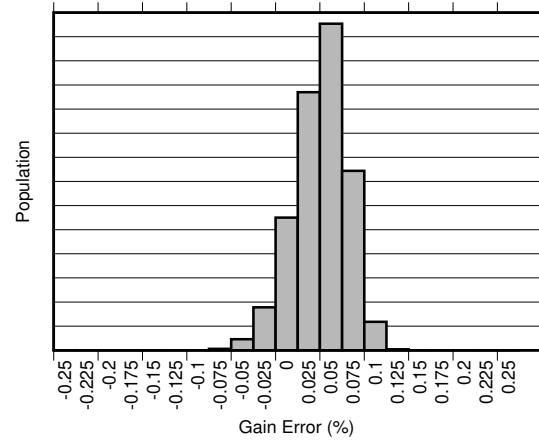

Figure 6-6. Gain Error Production Distribution (INA2191)

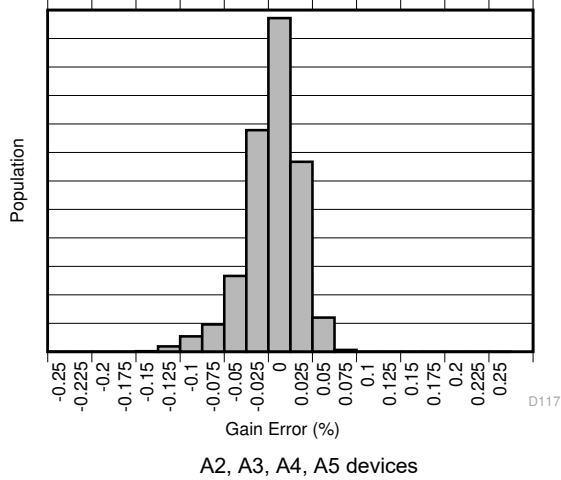

Figure 6-7. Gain Error Production Distribution

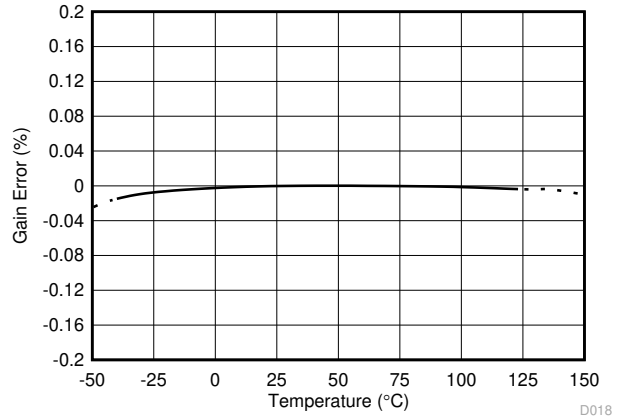

Figure 6-8. Gain Error vs. Temperature

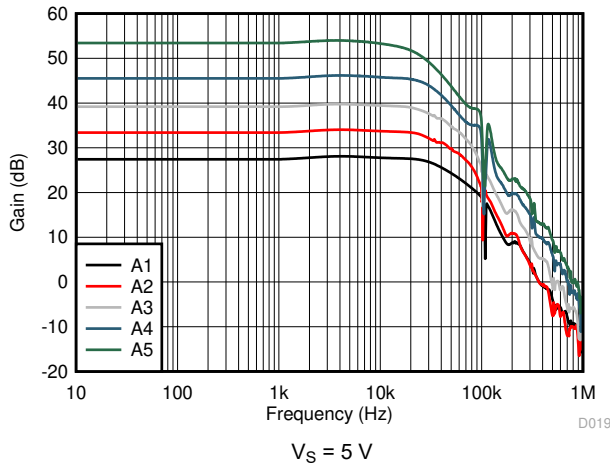

Figure 6-9. Gain vs. Frequency

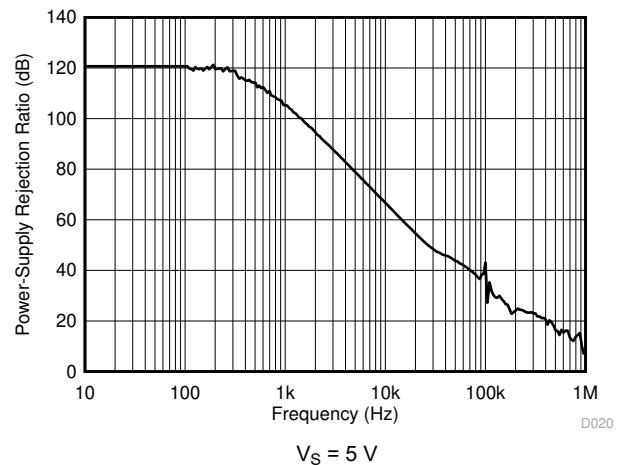

Figure 6-10. Power-Supply Rejection Ratio vs. Frequency

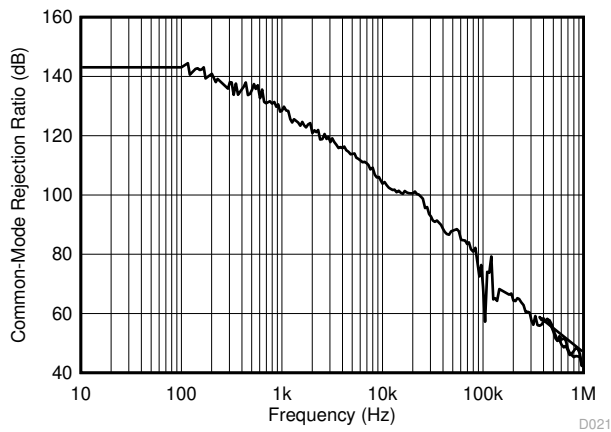

Figure 6-11. Common-Mode Rejection Ratio vs. Frequency

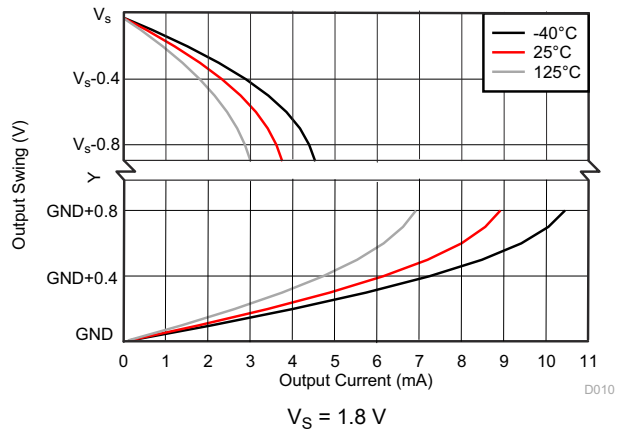

Figure 6-12. Output Voltage Swing vs. Output Current

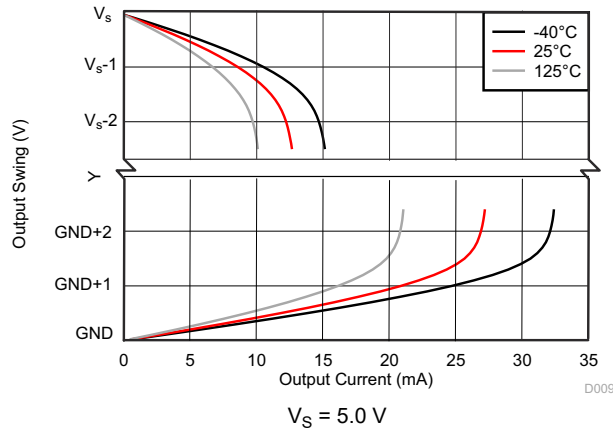

Figure 6-13. Output Voltage Swing vs. Output Current

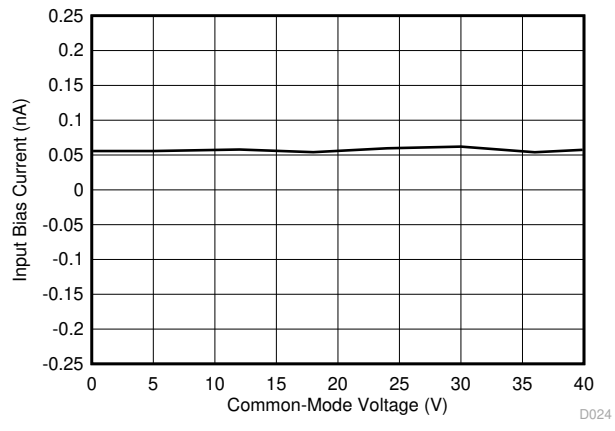

Figure 6-14. Input Bias Current vs. Common-Mode Voltage

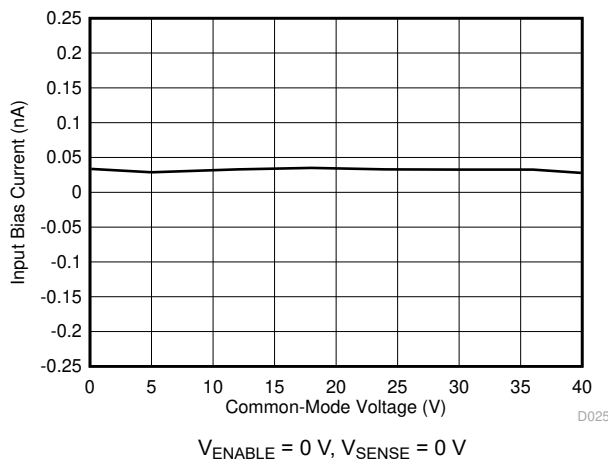

Figure 6-15. Input Bias Current vs. Common-Mode Voltage (Shutdown)

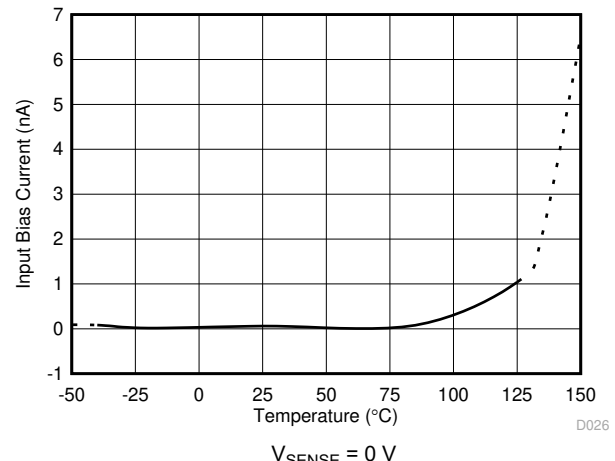

Figure 6-16. Input Bias Current vs. Temperature

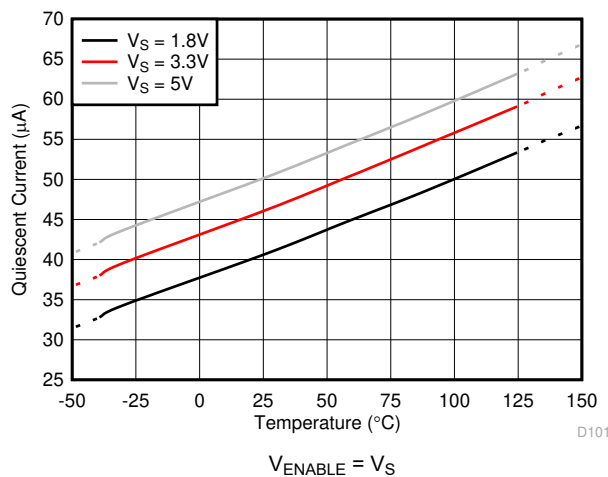

Figure 6-17. Quiescent Current vs. Temperature (INA191)

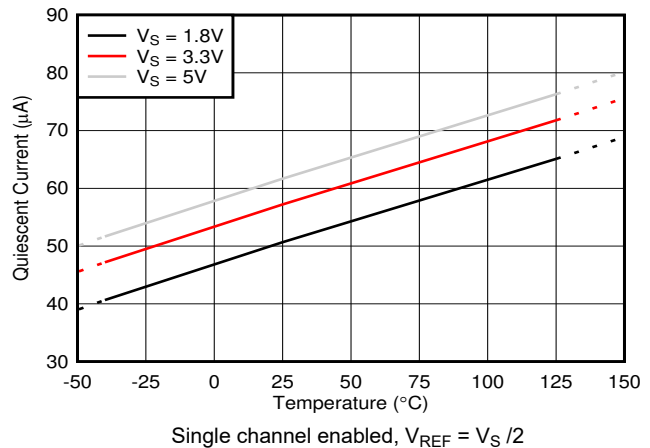

Figure 6-18. Quiescent Current vs. Temperature (INA2191)

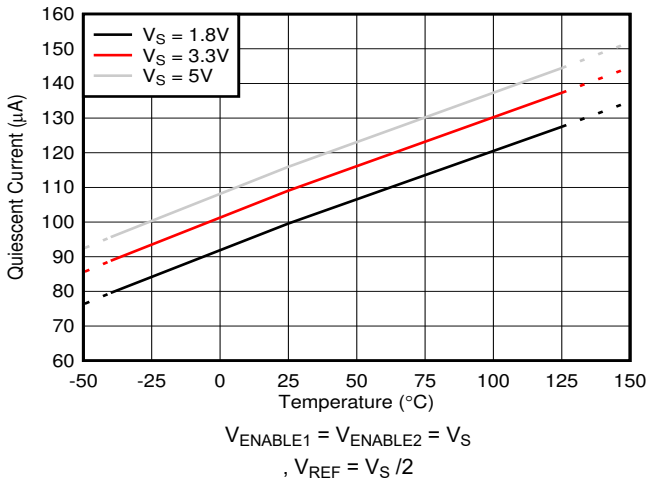

Figure 6-19. Quiescent Current vs. Temperature (INA2191)

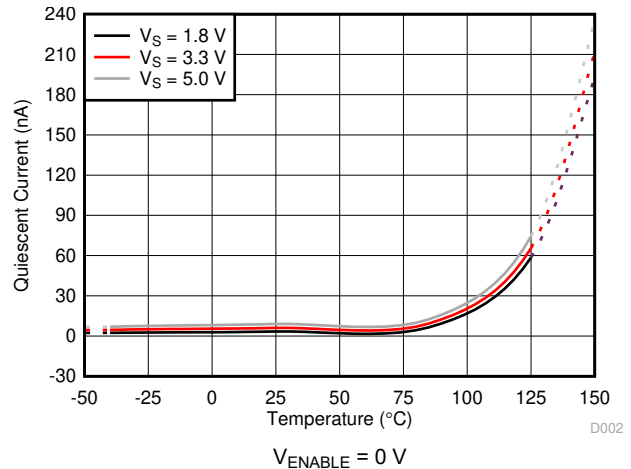

Figure 6-20. Quiescent Current vs. Temperature (INA191 Disabled)

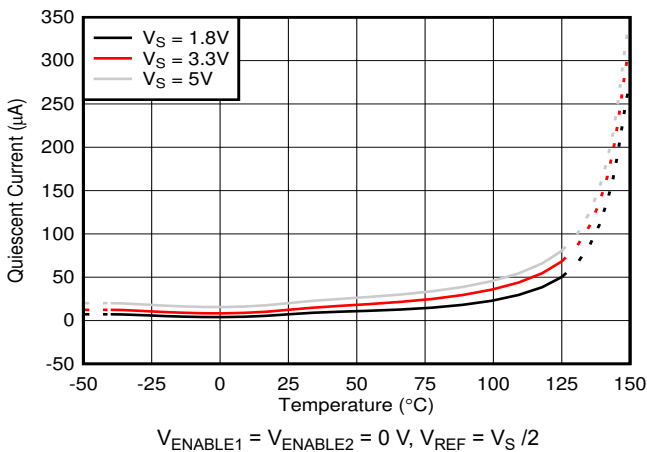

Figure 6-21. Quiescent Current vs. Temperature (INA2191 Disabled)

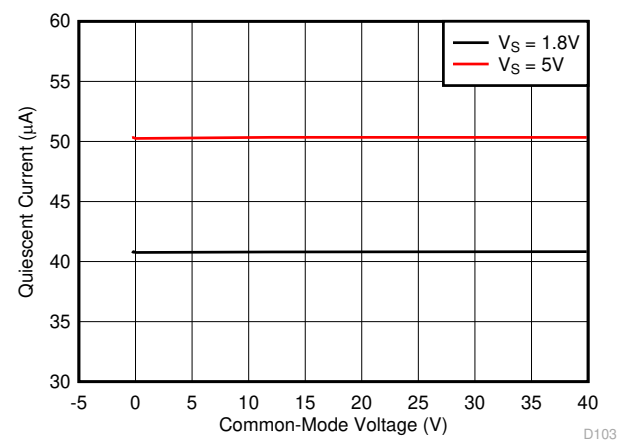

Figure 6-22. Quiescent Current vs. Common-Mode Voltage (INA191)

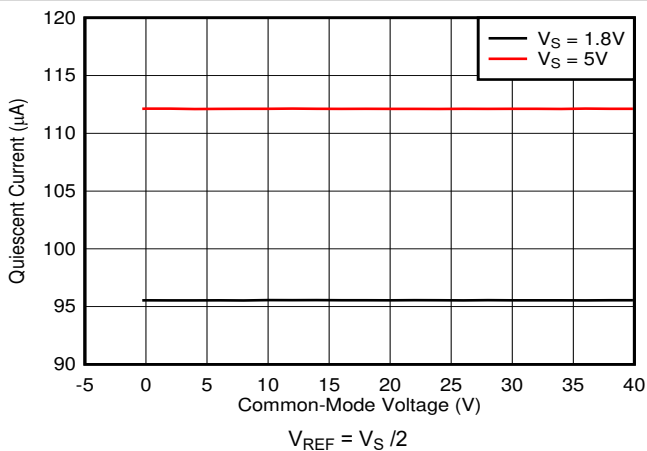

Figure 6-23. Quiescent Current vs. Common-Mode Voltage (INA2191)

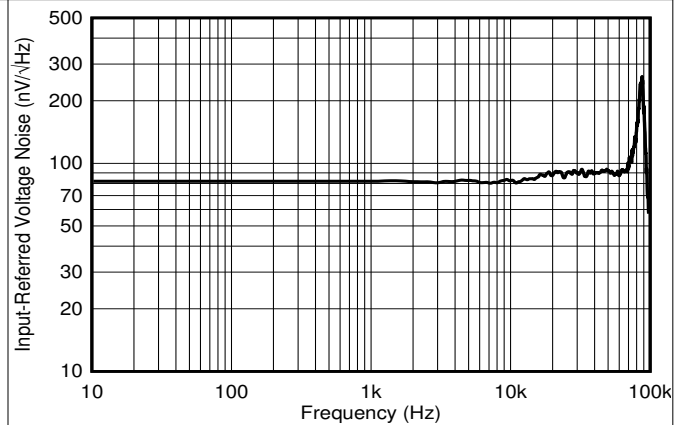
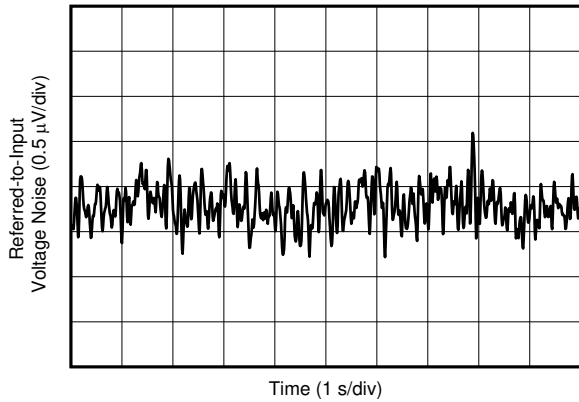
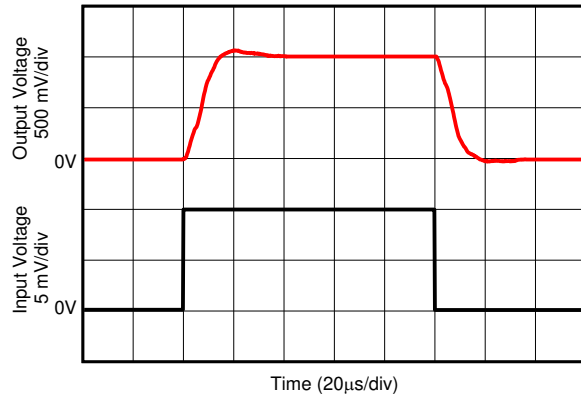

Figure 6-24. Input-Referred Voltage Noise vs. Frequency



D031

Figure 6-25. 0.1-Hz to 10-Hz Input-Referred Voltage Noise



D111

$V_S = 5.0 \text{ V}$, 10-mV_{PP} input step

Figure 6-26. Step Response

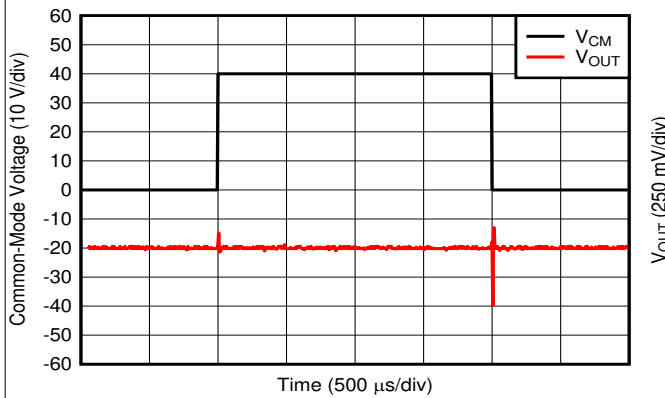
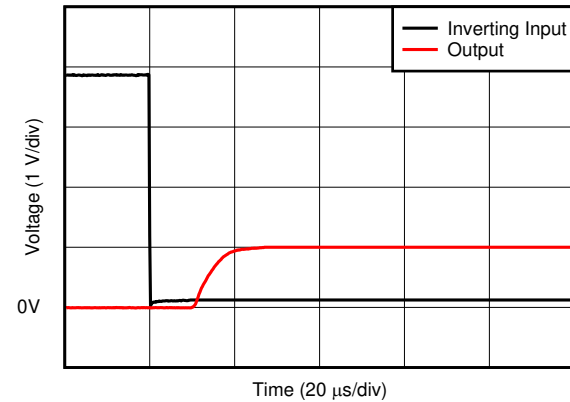
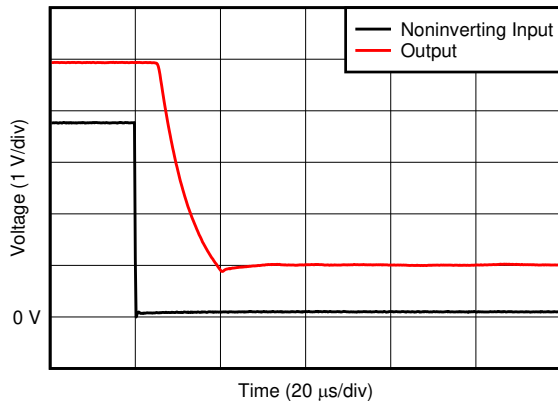

Figure 6-27. Common-Mode Voltage Transient Response



D114

Figure 6-28. Inverting Differential Input Overload Recovery



D113

$V_S = 5.0 \text{ V}$

Figure 6-29. Noninverting Differential Input Overload Recovery

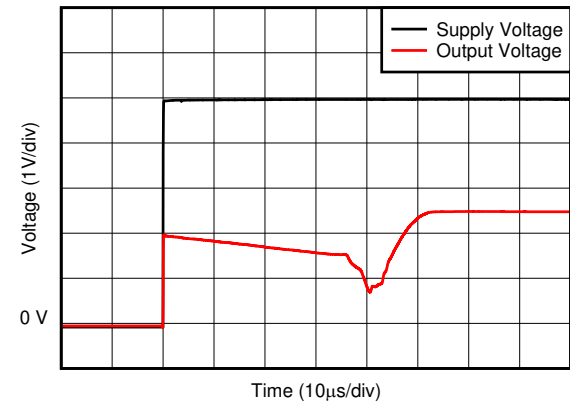

D108

$V_S = 5.0 \text{ V}$, A2 device

Figure 6-30. Start-Up Response

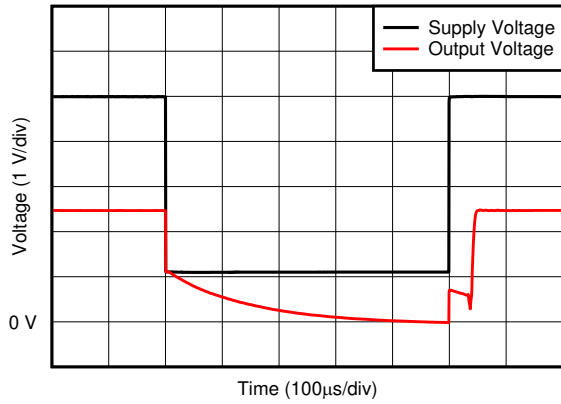

$V_S = 5.0\text{ V}$, A3 device

Figure 6-31. Brownout Recovery

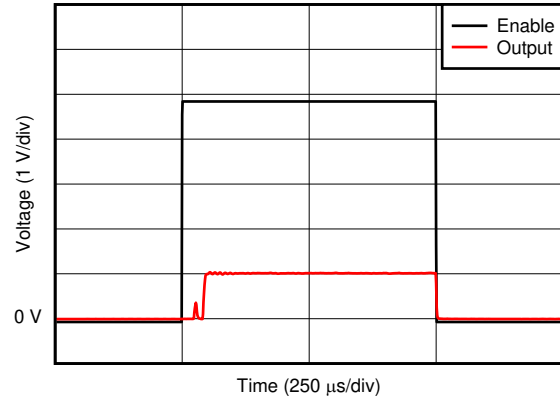

$V_S = 5.0\text{ V}$, A3 device

Figure 6-32. Enable and Disable Response

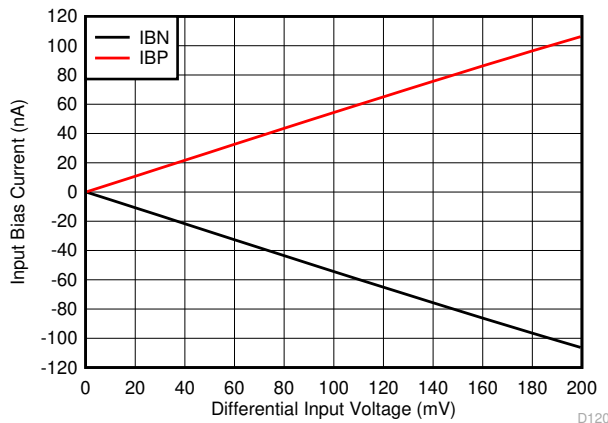

$V_S = 5.0\text{ V}$, A1 device

Figure 6-33. IB^+ and IB^- vs. Differential Input Voltage (INA191)

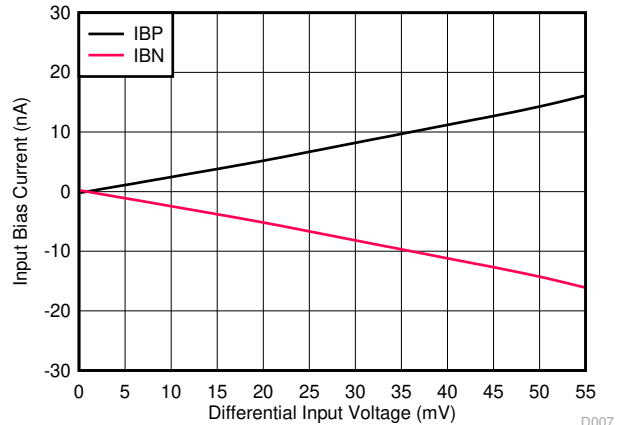

$V_S = 5.0\text{ V}$, A2, A3, A4, A5 devices

Figure 6-34. IB^+ and IB^- vs. Differential Input Voltage (INA191)

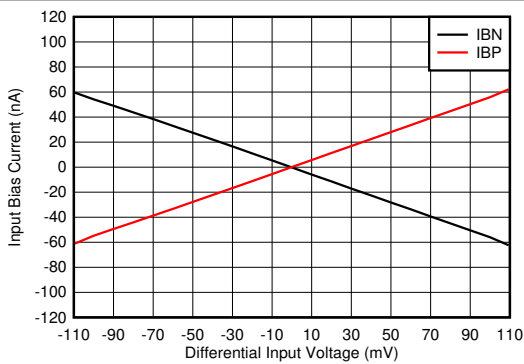

$V_S = 5.0\text{ V}$, $V_{REF} = V_S / 2$, A1 device

Figure 6-35. IB^+ and IB^- vs. Differential Input Voltage (INA2191)

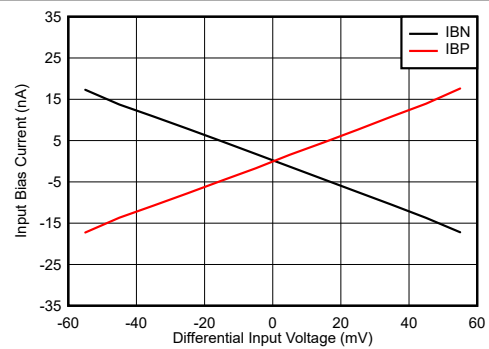

$V_S = 5.0\text{ V}$, $V_{REF} = V_S / 2$, A2, A3, A4, A5 devices

Figure 6-36. IB^+ and IB^- vs. Differential Input Voltage (INA2191)

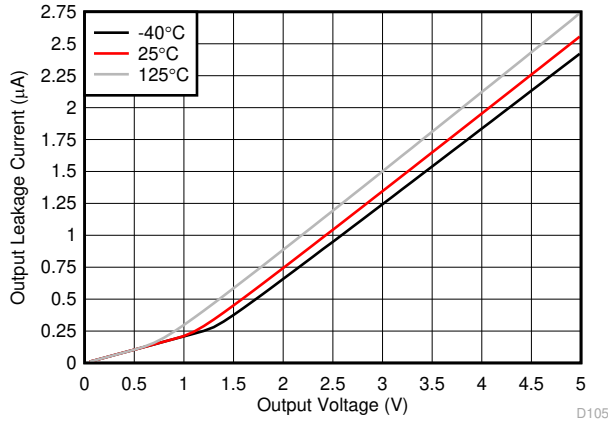

$V_S = 5.0\text{ V}$, $V_{ENABLE} = 0\text{ V}$, A1, A2, A3 devices

Figure 6-37. Output Leakage vs. Output Voltage

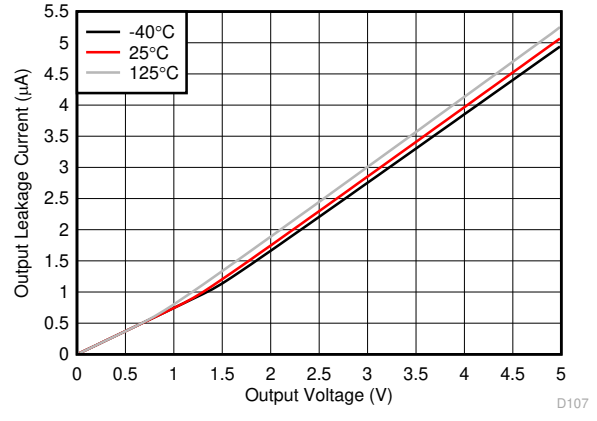

$V_S = 5.0\text{ V}$, $V_{ENABLE} = 0\text{ V}$, A4, A5 devices

Figure 6-38. Output Leakage vs. Output Voltage

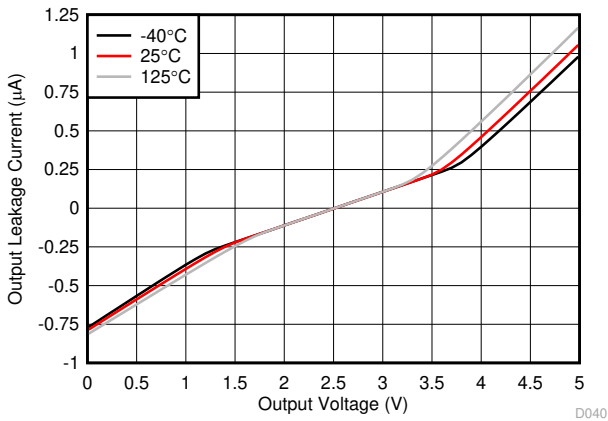

$V_S = 5.0\text{ V}$, $V_{ENABLE} = 0\text{ V}$, $V_{REF} = 2.5\text{ V}$, A1, A2, A3 devices

Figure 6-39. Output Leakage vs. Output Voltage (INA2191)

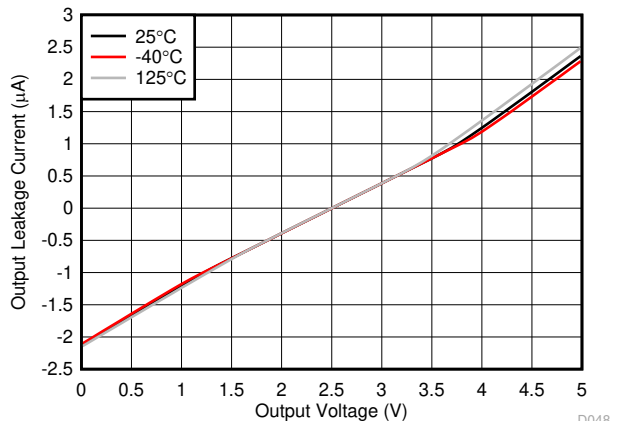

$V_S = 5.0\text{ V}$, $V_{ENABLE} = 0\text{ V}$, $V_{REF} = 2.5\text{ V}$, A4, A5 devices

Figure 6-40. Output Leakage vs. Output Voltage (INA2191)

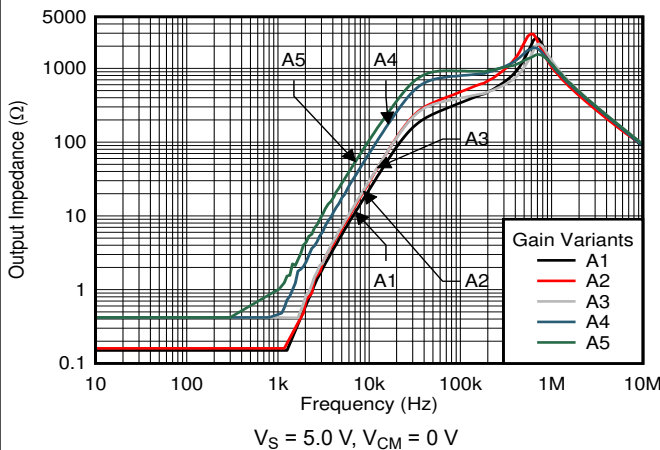

$V_S = 5.0\text{ V}$, $V_{CM} = 0\text{ V}$

Figure 6-41. Output Impedance vs. Frequency

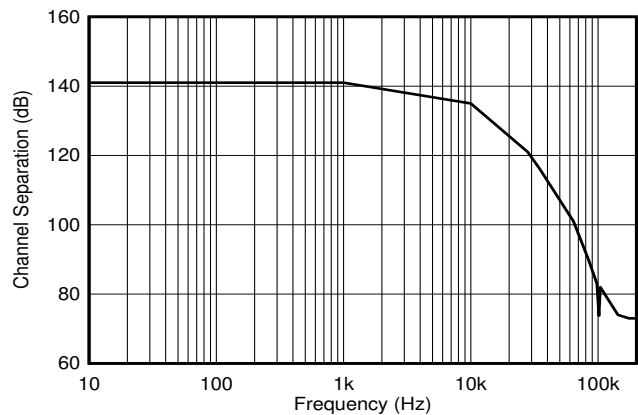

$V_S = 5.0\text{ V}$, $V_{CM} = 0\text{ V}$, $V_{REF} = V_S / 2$

Figure 6-42. Channel Separation vs. Frequency (INA2191)

7 Detailed Description

7.1 Overview

The INAx191 is a low bias current, 40-V common-mode, current-sensing amplifier with an enable pin. When disabled, the output goes to a high-impedance state, and the supply current draw is reduced to less than 0.1 μA per channel. The INAx191 is intended for use in either low-side and high-side current-sensing configurations where high accuracy and low current consumption are required. The INAx191 is a specially designed current-sensing amplifier, that accurately measure voltages developed across current-sensing resistors on common-mode voltages that far exceed the supply voltage. Current can be measured on input voltage rails as high as 40 V, with a supply voltage (V_S) as low as 1.7 V.

7.2 Functional Block Diagram

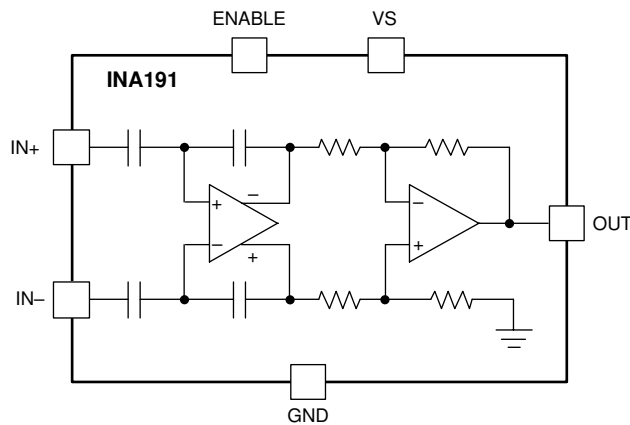

Figure 7-1. INA191 Diagram

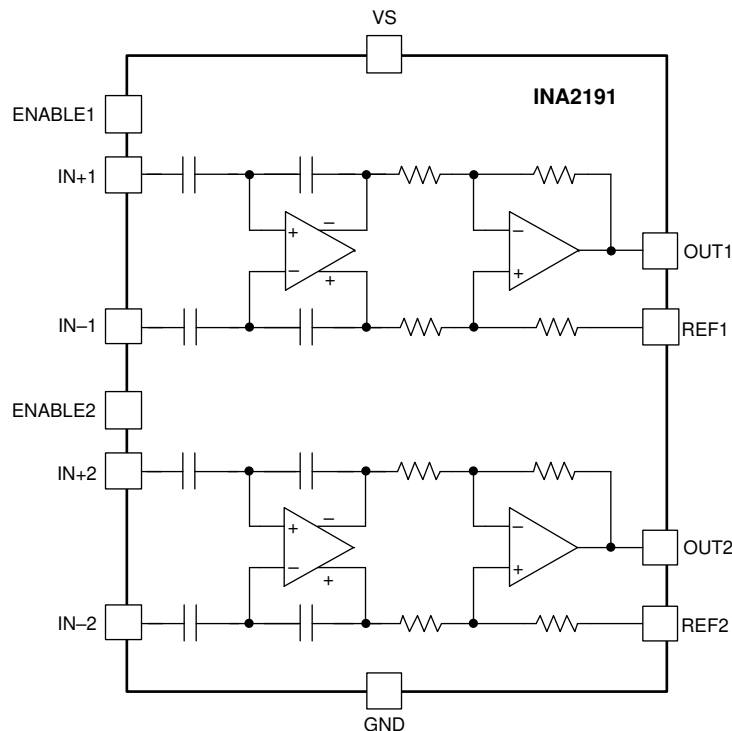

Figure 7-2. INA2191 Diagram

7.3 Feature Description

7.3.1 Precision Current Measurement

The INAx191 provides accurate current measurements over a wide dynamic range. The high accuracy of the device is attributable to the low gain error and offset specifications. The offset voltage of the INAx191 is less than 12 μV . In this case, the low offset improves the accuracy at light loads when $V_{\text{IN}+}$ approaches $V_{\text{IN}-}$.

Another advantage of low offset is the ability to use a lower-value shunt resistor that reduces the power loss in the current-sense circuit, and improves the power efficiency of the end application.

The maximum gain error of the INAx191 is specified to be within 0.25% for most gain options. As the sensed voltage becomes much larger than the offset voltage, the gain error becomes the dominant source of error in the current-sense measurement. When the device monitors currents near the full-scale output range, the total measurement error approaches the value of the gain error.

7.3.2 Low Input Bias Current

The INAx191 is different from many current-sense amplifiers because this device offers very low input bias current. The low input bias current of the INAx191 has three primary benefits.

The first benefit is the reduction of the current consumed by the device in both the enabled and disabled states. Classical current-sense amplifier topologies typically consume tens of microamps of current at the inputs. For these amplifiers, the input current is the result of the resistor network that sets the gain and additional current to bias the input amplifier. To reduce the bias current to near zero, the INAx191 uses a capacitively coupled amplifier on the input stage, followed by a difference amplifier on the output stage.

The second benefit of low bias current is the ability to use input filters to reject high-frequency noise before the signal is amplified. In a traditional current-sense amplifier, the addition of input filters comes at the cost of reduced accuracy. However, as a result of the low bias currents, input filters have little effect on the measurement accuracy of the INAx191.

The third benefit of low bias current is the ability to use a larger current-sense resistor. This ability allows the device to accurately monitor currents as low as 1 μA .

7.3.3 Low Quiescent Current With Output Enable

The device features low quiescent current (I_{Q}), while still providing sufficient small-signal bandwidth to be usable in most applications. The quiescent current of the INA191 is only 43 μA (typical), while providing a small-signal bandwidth of 35 kHz in a gain of 100. The low I_{Q} and good bandwidth allow the device to be used in many portable electronic systems without excessive drain on the battery. Because many applications only need to periodically monitor current, the INAx191 features an enable pin for each output that turns off the device until needed. When in the disabled state, the INAx191 typically draws 10 nA of total supply current per channel.

7.3.4 Bidirectional Current Monitoring (INA2191 Only)

The INA2191 can sense current flow through a sense resistor in both directions. The bidirectional current-sensing capability is achieved by applying a voltage at the REF pin to offset the desired output voltage. A positive differential voltage sensed at the inputs results in an output voltage that is greater than the applied reference voltage. Likewise, a negative differential voltage at the inputs results in output voltage that is less than the applied reference voltage. The output voltage of the current-sense amplifier is shown in [Equation 1](#). Equation variables such as V_{OUT} are valid for either $V_{\text{OUT}1}$ or $V_{\text{OUT}2}$ depending on which channel used.

$$V_{\text{OUT}} = (I_{\text{LOAD}} \times R_{\text{SENSE}} \times \text{GAIN}) + V_{\text{REF}} \quad (1)$$

where

- I_{LOAD} is the load current to be monitored.
- R_{SENSE} is the current-sense resistor.
- GAIN is the gain option of the selected device.
- V_{REF} is the voltage applied to the REF pin.

7.3.5 High-Side and Low-Side Current Sensing

The INAx191 supports input common-mode voltages from -0.2 V to $+40\text{ V}$. Because of the internal topology, the common-mode range is not restricted by the power-supply voltage (V_S). The ability to operate with common-mode voltages greater or less than V_S allows the INAx191 to be used in high-side and low-side current-sensing applications, as shown in Figure 7-3.

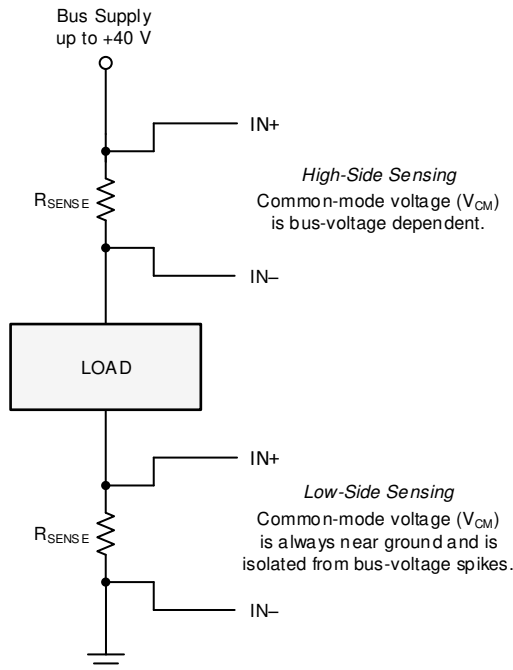

Figure 7-3. High-Side and Low-Side Sensing Connections

7.3.6 High Common-Mode Rejection

The INAx191 uses a capacitively coupled amplifier on the front end. Therefore, dc common-mode voltages are blocked from downstream circuits, resulting in very high common-mode rejection. The common-mode rejection of the INAx191 is 150 dB (typical). The ability to reject changes in the DC common-mode voltage allows the INAx191 to monitor both high- and low-voltage rail currents with very little change in the offset voltage.

7.3.7 Rail-to-Rail Output Swing

The INAx191 supports linear current-sensing operation with the output close to the supply rail and ground. The maximum specified output swing to the positive rail is $V_S - 40\text{ mV}$, and the maximum specified output swing to GND is only $\text{GND} + 1\text{ mV}$ with -10 mV of differential overdrive. For cases where the sense current is zero, the swing to ground is determined by the zero current output specification. The value of the zero current output voltage can differ from the specified value depending on the common-mode voltage, supply voltage, and output load. The close-to-rail output swing maximizes the usable output range, particularly when operating the device from a 1.8-V supply.

7.4 Device Functional Modes

7.4.1 Normal Operation

The INAx191 is in normal operation when the following conditions are met:

- The power-supply voltage (V_S) is between 1.7 V and 5.5 V.
- The common-mode voltage (V_{CM}) is within the specified range of -0.2 V to $+40$ V.
- The maximum differential input signal times the gain plus V_{REF} is less than the positive output voltage swing V_{SP} . $V_{REF} = 0$ V for INA191.
- The ENABLE pin is driven or connected to V_S .
- The minimum differential input signal times the gain plus V_{REF} is greater than the swing to GND, V_{ZL} (see Section 7.3.7). $V_{REF} = 0$ V for INA191.

During normal operation, this device produces an output voltage that is the *amplified* representation of the difference voltage from IN+ to IN– plus the voltage applied to the REF pin. For devices without a REF pin the REF voltage is 0 V.

7.4.2 Unidirectional Mode

The INA191 always monitors current flow in a single direction, however, the INA2191 can be configured to monitor current flowing in one direction (unidirectional) or in both directions (bidirectional) depending on how the REF pin is connected. The most common case is unidirectional where the output is set to ground when no current is flowing by connecting the REF pin to ground, as shown in Figure 7-4. When the current flows from the bus supply to the load, the input voltage from IN+ to IN– increases and causes the output voltage at the OUT pin to increase. Pin names such as OUT apply to either OUT1 or OUT2 in the diagrams below depending on which channel is used.

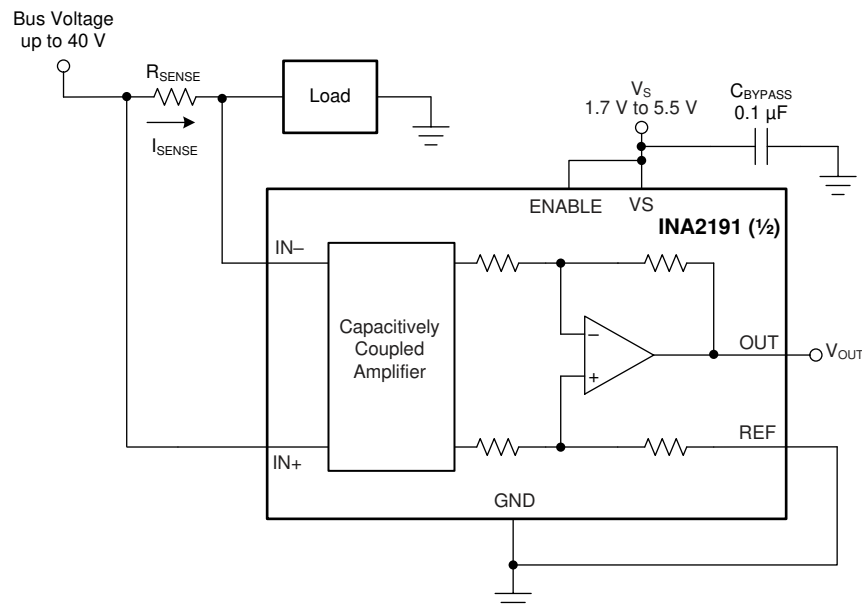

Figure 7-4. Typical Unidirectional Application

The linear range of the output stage is limited by how close the output voltage can approach ground under zero input conditions. The zero current output voltage of the INA2191 is very small and for most unidirectional applications the REF pin is simply grounded. However, if the measured current multiplied by the current sense resistor and device gain is less than the zero current output voltage then bias the REF pin to a convenient value above the zero current output voltage to get the output into the linear range of the device. To limit reference rejection errors, buffer the reference voltage connected to the REF pin.

A less-frequently used output biasing method is to connect the REF pin to the power-supply voltage, V_S . This method results in the output voltage saturating at 40 mV less than the supply voltage when no differential input voltage is present. This method is similar to the output saturated low condition with no differential input voltage

when the REF pin is connected to ground. The output voltage in this configuration only responds to currents that develop negative differential input voltage relative to the device IN⁻ pin. Under these conditions, when the negative differential input signal increases, the output voltage moves downward from the saturated supply voltage. The voltage applied to the REF pin must not exceed V_S.

Another use for the REF pin in unidirectional operation is to level shift the output voltage. Figure 7-5 shows an application where the device ground is set to a negative voltage so currents biased to negative supplies, as seen in optical networking cards, can be measured. The GND of the INA2191 can be set to negative voltages, as long as the inputs do not violate the common-mode range specification and the voltage difference between V_S and GND does not exceed 5.5 V. In this example, the output of the INA2191 is fed into a positive-biased ADC. By grounding the REF pin, the voltages at the output will be positive and not damage the ADC. To make sure the output voltage never goes negative, the supply sequencing must be the positive supply first, followed by the negative supply.

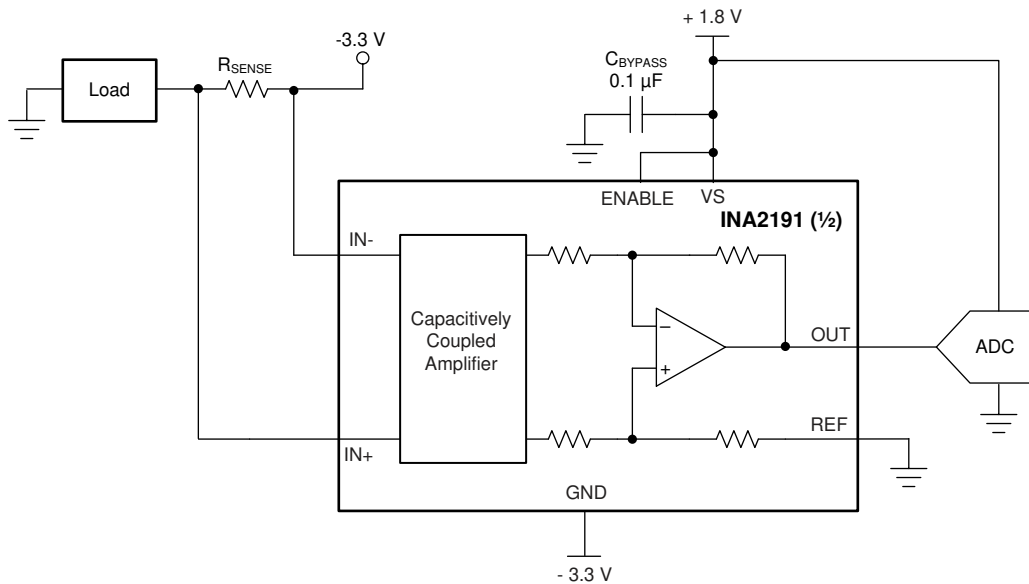

Figure 7-5. Using the REF Pin to Level-Shift Output Voltage

7.4.3 Bidirectional Mode (INA2191 Only)

The INA2191 is a dual channel bidirectional current-sense amplifier capable of measuring currents through a resistive shunt in two directions. This bidirectional monitoring is common in applications that include charging and discharging operations where the current flowing through the resistor can change directions.

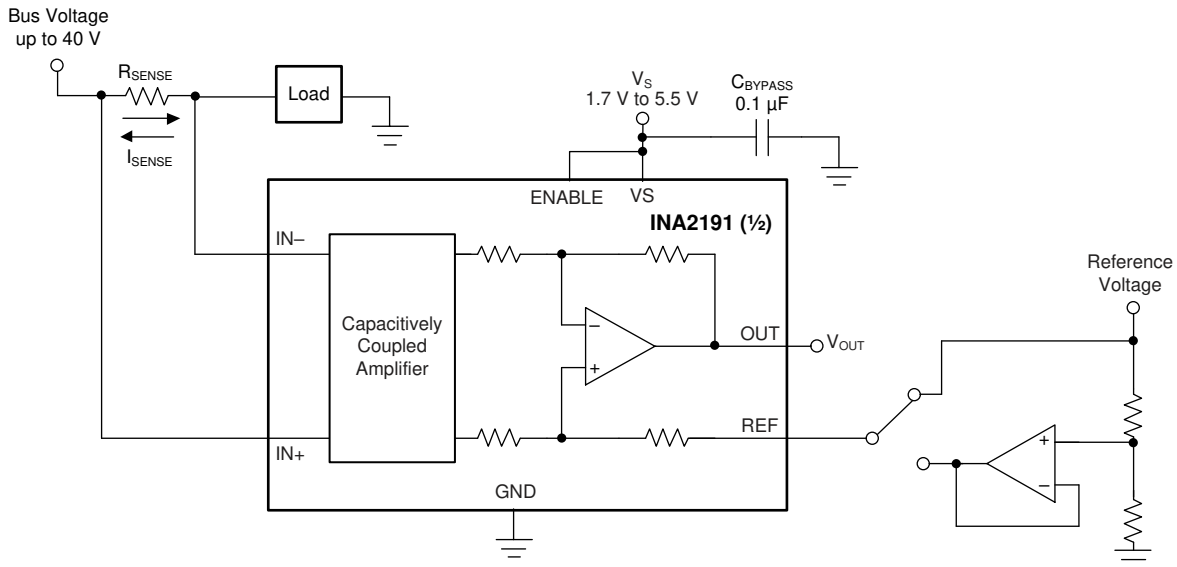

Figure 7-6. Bidirectional Application

The ability to measure this current flowing in both directions is achieved by applying a voltage to the REF pin, as shown in [Figure 7-6](#). The voltage applied to REF (V_{REF}) sets the output state that corresponds to the zero-input level state. The output then responds by increasing above V_{REF} for positive differential signals (relative to the IN- pin) and responds by decreasing below V_{REF} for negative differential signals. This reference voltage applied to the REF pin can be set anywhere between 0 V to V_S . For bidirectional applications, V_{REF} is typically set at $V_S/2$ for equal signal range in both current directions. In some cases, V_{REF} is set at a voltage other than $V_S/2$, like when the bidirectional current and corresponding output signal do not need to be symmetrical.

7.4.4 Input Differential Overload

If the differential input voltage ($V_{IN+} - V_{IN-}$) times gain (plus V_{REF} for INA2191) exceeds the voltage swing specification, the INAx191 drives the output as close as possible to the positive supply or ground, and does not provide accurate measurement of the differential input voltage. If this input overload occurs during normal circuit operation, then reduce the value of the shunt resistor or use a lower-gain version with the chosen sense resistor to avoid this mode of operation. If a differential overload occurs in a fault event, then the output of the INAx191 returns to the expected value approximately 40 μ s after the fault condition is removed. When the differential voltage exceeds approximately 300 mV, the differential input impedance reduces to 3.3 k Ω , and results in a rapid increase in bias currents as the differential voltage increases. A 3.3-k Ω resistance exists between IN+ and IN- during a differential overload condition; therefore, currents flowing into the IN+ pin flow out of the IN- pin. An increase in bias currents during an input differential overload occurs even with the device is powered down. Input differential overloads less than the absolute maximum voltage rating do not damage the device or result in an output inversion.

7.4.5 Shutdown

The INAx191 features an active-high ENABLE pin(s) that shuts down the device when pulled to ground. When the device is shut down, the quiescent current is reduced to 10 nA per channel (typical), the input bias currents are further reduced, and the disabled output goes to a high-impedance state. When disabled, the low quiescent and input currents extend the battery lifetime when the current measurement is not needed. When the ENABLE pin is driven above the enable threshold voltage, the device turns back on. When enabled, the typical output settling time is 130 μ s.

The output of the INAx191 goes to a high-impedance state when disabled; therefore, it is possible to connect multiple outputs of the INAx191 together to a single ADC or measurement device, as shown in Figure 7-7. When connected in this way, enable only one INAx191 at a time, and make sure both devices have the same supply voltage. Using the INA2191 with the same approach as shown in Figure 7-7 provides the capability to monitor two currents with a single device.

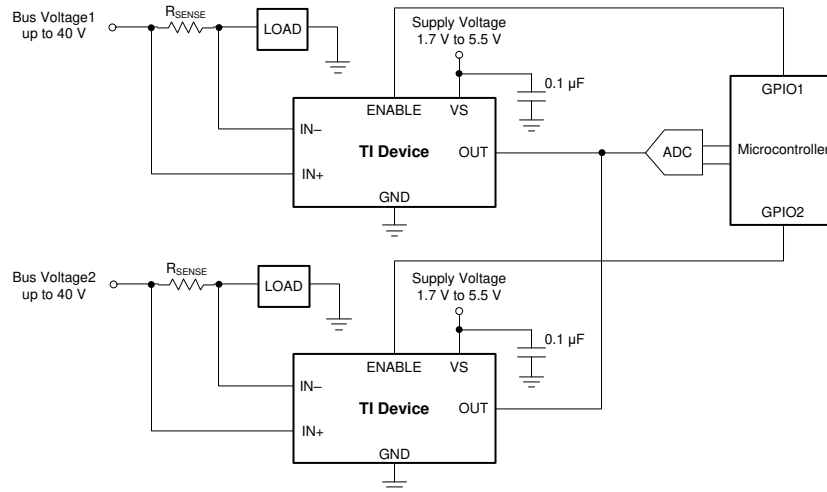

Figure 7-7. Multiplexing Multiple Devices With the ENABLE Pin

8 Application and Implementation

Note

Information in the following applications sections is not part of the TI component specification, and TI does not warrant its accuracy or completeness. TI's customers are responsible for determining suitability of components for their purposes, as well as validating and testing their design implementation to confirm system functionality.

8.1 Application Information

The INAx191 amplifies the voltage developed across a current-sensing resistor as current flows through the resistor to the load or ground.

8.1.1 Basic Connections

Figure 8-1 shows the basic connections of the INAx191. Connect the input pins (IN+ and IN-) as closely as possible to the shunt resistor to minimize any resistance in series with the shunt resistor. The ENABLE pin must be controlled externally or connected to VS if not used.

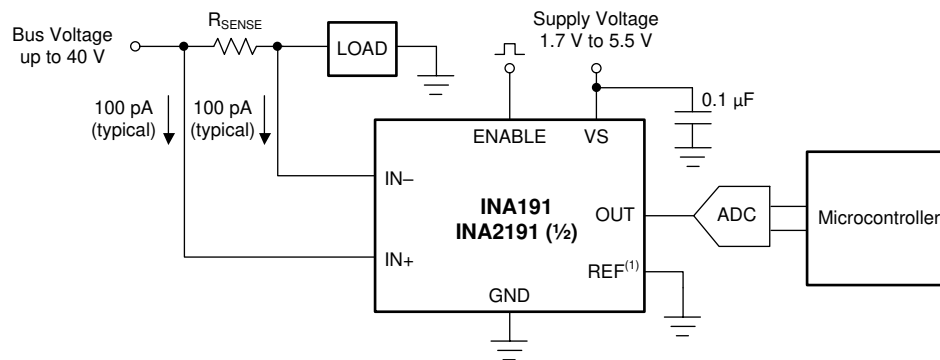

(1) REF pin only available on INA2191

Figure 8-1. Basic Connections for the INAx191

A power-supply bypass capacitor of at least 0.1 μF is required for proper operation. Applications with noisy or high-impedance power supplies may require additional decoupling capacitors to reject power-supply noise. Connect bypass capacitors close to the device pins.

8.1.2 R_{SENSE} and Device Gain Selection

The accuracy of any current-sense amplifier is maximized by choosing the current-sense resistor to be as large as possible. A large sense resistor maximizes the differential input signal for a given amount of current flow and reduces the error contribution of the offset voltage. However, there are practical limits as to how large the current-sense resistor can be in a given application because of the resistor size and maximum allowable power dissipation. Equation 2 gives the maximum value for the current-sense resistor for a given power dissipation budget:

$$R_{\text{SENSE}} < \frac{PD_{\text{MAX}}}{I_{\text{MAX}}^2} \quad (2)$$

where:

- PD_{MAX} is the maximum allowable power dissipation in R_{SENSE}.
- I_{MAX} is the maximum current that flows through R_{SENSE}.

An additional limitation on the size of the current-sense resistor and device gain is due to the power-supply voltage, V_S, and device swing-to-rail limitations. In order to make sure that the current-sense signal is properly passed to the output, both positive and negative output swing limitations must be examined. Equation 3 provides the maximum values of R_{SENSE} and GAIN to keep the device from hitting the positive swing limitation.

$$I_{\text{MAX}} \times R_{\text{SENSE}} \times \text{GAIN} < V_{\text{SP}} - V_{\text{REF}} \quad (3)$$

where:

- I_{MAX} is the maximum current that flows through R_{SENSE}.
- GAIN is the gain of the current-sense amplifier.
- V_{SP} is the positive output swing as specified in the data sheet.
- V_{REF} is the reference input. This node is internally grounded for the INA191 and a value of 0 V should be used for that device.

To avoid positive output swing limitations when selecting the value of R_{SENSE}, there is always a trade-off between the value of the sense resistor and the gain of the device under consideration. If the sense resistor selected for the maximum power dissipation is too large, then it is possible to select a lower-gain device in order to avoid positive swing limitations.

The zero current output voltage places a limit on how small of a sense resistor can be used in a given application. Equation 4 provides the limit on the minimum size of the sense resistor.

$$I_{\text{MIN}} \times R_{\text{SENSE}} \times \text{GAIN} > V_{\text{ZL}} - V_{\text{REF}} \quad (4)$$

where:

- I_{MIN} is the minimum current flows through R_{SENSE}.
- GAIN is the gain of the current-sense amplifier.
- V_{ZL} is the zero current output voltage of the device (see the [Section 7.3.7](#) section for more information).
- V_{REF} is the reference input. This node is internally grounded for the INA191 and a value of 0 V should be used for that device.

8.1.3 Signal Conditioning

When performing accurate current measurements in noisy environments, the current-sensing signal is often filtered. The INAx191 features low input bias currents. Therefore, it is possible to add a differential mode filter to the input without sacrificing the current-sense accuracy. Filtering at the input is advantageous because this action attenuates differential noise before the signal is amplified. Figure 8-2 provides an example of how to use a filter on the input pins of the device.

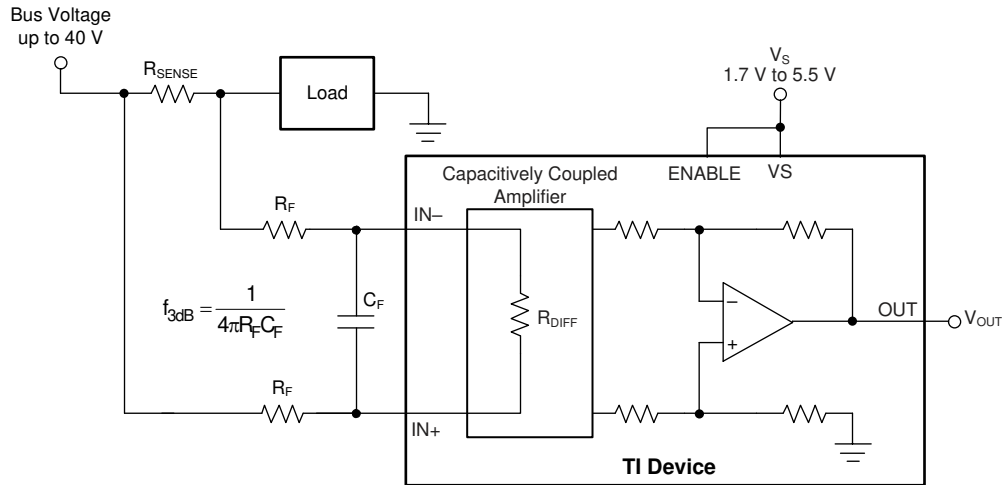

Figure 8-2. Filter at the Input Pins

The differential input impedance (R_{DIFF}) shown in Figure 8-2 limits the maximum value for R_F . The value of R_{DIFF} is a function of the device temperature and gain option, as shown in Figure 8-3.

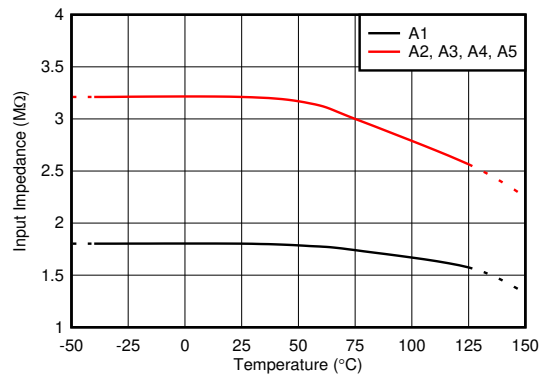

Figure 8-3. Differential Input Impedance vs. Temperature

As the voltage drop across the sense resistor (V_{SENSE}) increases, the amount of voltage dropped across the input filter resistors (R_F) also increases. The increased voltage drop results in additional gain error. The error caused by these resistors is calculated by the resistor divider equation shown in [Equation 5](#).

$$\text{Error(\%)} = \left(1 - \frac{R_{\text{DIFF}}}{R_{\text{SENSE}} + R_{\text{DIFF}} + (2 \times R_F)} \right) \times 100 \quad (5)$$

where:

- R_{SENSE} is the current sense resistor, as defined in [Equation 2](#).
- R_{DIFF} is the differential input impedance.
- R_F is the added value of the series filter resistance.

The input stage of the INAx191 uses a capacitive feedback amplifier topology in order to achieve high DC precision. As a result, periodic high-frequency shunt voltage (or current) transients of significant amplitude (10 mV or greater) and duration (hundreds of nanoseconds or greater) may be amplified by the INAx191, even though the transients are greater than the device bandwidth. Use a differential input filter in these applications to minimize disturbances at the INAx191 output.

The high input impedance and low bias current of the INAx191 provides flexibility in the input filter design without impacting the accuracy of current measurement. For example, set $R_F = 100 \, \Omega$ and $C_F = 22 \, \text{nF}$ to achieve a low-pass filter corner frequency of 36.2 kHz. These filter values significantly attenuate most unwanted high-frequency signals at the input without severely impacting the current-sensing bandwidth or precision. If a lower corner frequency is desired, increase the value of C_F .

Filtering at the input reduces differential noise across the sense resistor. If high-frequency, common-mode noise is a concern, add an RC filter from the OUT pin to ground. The RC filter helps filter out both differential and common mode noise, as well as internally generated noise from the device. The value for the resistance of the RC filter is limited by the impedance of the output load. Any current drawn by the load manifests as an external voltage drop from the INAx191 OUT pin to the load input. To select the optimal values for the output filter when driving SAR ADCs or other dynamic loads, use [Figure 6-41](#) and see the [Closed-Loop Analysis of Load-Induced Amplifier Stability Issues Using ZOUT Application Report](#)

8.1.4 Common-Mode Voltage Transients

With a small amount of additional circuitry, the INAx191 can be used in circuits subject to transients that exceed the absolute maximum voltage ratings. The most simple way to protect the inputs from negative transients is to add resistors in series to the IN⁻ and IN⁺ pins. Use resistors that are 1 k Ω or less, and limit the current in the ESD structures to less than 5 mA. For example, using 1-k Ω resistors in series with the INAx191 allows voltages as low as -5 V, while limiting the ESD current to less than 5 mA. If protection from high-voltage or more-negative, common-voltage transients is needed, use the circuits shown in [Figure 8-4](#) and [Figure 8-5](#). When implementing these circuits, use only Zener diodes or Zener-type transient absorbers (sometimes referred to as *transzorb*s); any other type of transient absorber has an unacceptable time delay. Start by adding a pair of resistors as a working impedance for the Zener diode, as shown in [Figure 8-4](#). Keep these resistors as small as possible; most often, use around 100 Ω . Larger values can be used with an effect on gain that is discussed in [Section 8.1.3](#). This circuit limits only short-term transients; therefore, many applications are satisfied with a 100- Ω resistor along with conventional Zener diodes of the lowest acceptable power rating. This combination uses the least amount of board space. These diodes can be found in packages as small as SOT-523 or SOD-523.

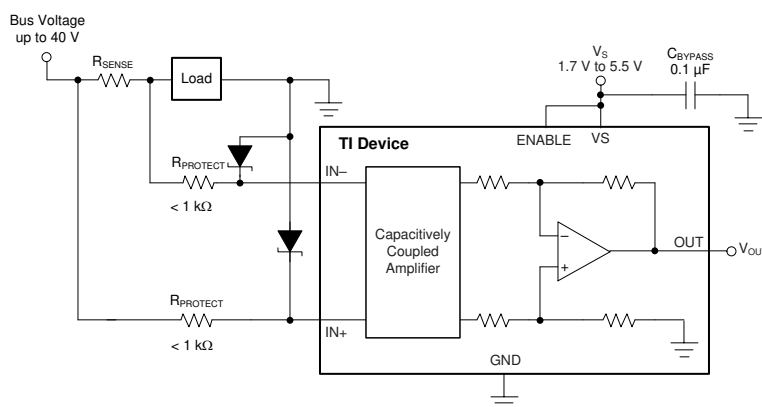

Figure 8-4. Transient Protection Using Dual Zener Diodes

In the event that low-power Zener diodes do not have sufficient transient absorption capability, a higher-power transzorb must be used. The most package-efficient solution involves using a single transzorb and back-to-back diodes between the device inputs, as shown in [Figure 8-5](#). The most space-efficient solutions are dual, series-connected diodes in a single SOT-523 or SOD-523 package. In either of the examples shown in [Figure 8-4](#) and [Figure 8-5](#), the total board area required by the INA191 with all protective components is less than that of an SO-8 package, and only slightly greater than that of an VSSOP-8 package.

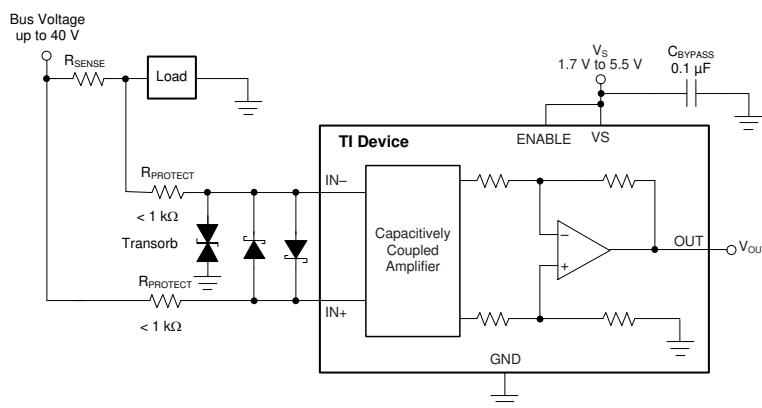

Figure 8-5. Transient Protection Using a Single Transzorb and Input Clamps

For more information, see [Current Shunt Monitor With Transient Robustness Reference Design](#).

8.2 Typical Application

8.2.1 Microamp Current Measurement

The low input bias current of the INAx191 provides accurate monitoring of small-value currents. To accurately monitor currents in the microamp range, increase the value of the sense resistor to increase the sense voltage so that the error introduced by the offset voltage is small. The circuit configuration to monitor low-value currents is shown in Figure 8-6. As a result of the differential input impedance of the INAx191, limit the value of R_{SENSE} to 1 k Ω or less for best accuracy.

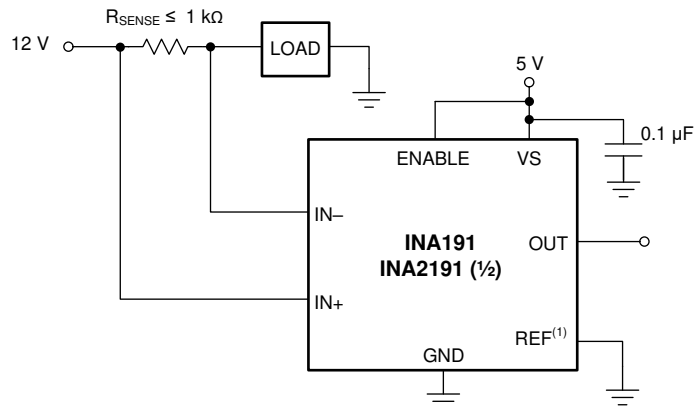

(1) REF pin only available on INA2191

Figure 8-6. Measuring Microamp Currents

8.2.1.1 Design Requirements

The design requirements for the circuit shown in Figure 8-6, are listed in Table 8-1

Table 8-1. Design Parameters

DESIGN PARAMETER	EXAMPLE VALUE
Power-supply voltage (V_S)	5 V
Bus supply rail (V_{CM})	12 V
Minimum sense current (I_{MIN})	1 μ A
Maximum sense current (I_{MAX})	150 μ A
Device gain (GAIN)	25 V/V
Unidirectional Application	$V_{REF} = 0$ V

8.2.1.2 Detailed Design Procedure

The maximum value of the current-sense resistor is calculated based on choice of gain, value of the maximum current the be sensed (I_{MAX}), and the power supply voltage (V_S). When operating at the maximum current, the output voltage must not exceed the positive output swing specification, V_{SP} . For the given design parameters, the maximum value for R_{SENSE} calculated in Equation 6 is 1.321 k Ω .

$$R_{SENSE} < \frac{V_{SP}}{I_{MAX} \times GAIN} \quad (6)$$

However, because this value exceeds the maximum recommended value for R_{SENSE} , a resistance value of 1 k Ω must be used. When operating at the minimum current value, I_{MIN} the output voltage must be greater than the swing to GND (V_{SN}), specification. For this example, the output voltage at the minimum current (V_{OUTMIN}) calculated in Equation 7 is 25 mV, which is greater than the value for V_{SN} .

$$V_{OUTMIN} = I_{MIN} \times R_{SENSE} \times GAIN \quad (7)$$

8.2.1.3 Application Curve

Figure 8-7 shows the output of the device when disabled and enabled while measuring a 40- μ A load current. When disabled, the current draw from the device supply and inputs is less than 106 nA.

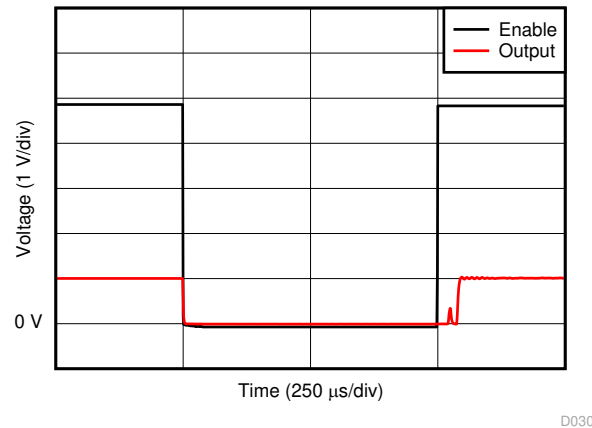

Figure 8-7. Output Disable and Enable Response

9 Power Supply Recommendations

The input circuitry of the INAx191 accurately measures beyond the power-supply voltage, V_S . For example, V_S can be 5 V, whereas the bus supply voltage at IN+ and IN– can be as high as 40 V. However, the output voltage range of the OUT pin is limited by the voltage on the VS pin. The INAx191 also withstands the full differential input signal range up to 40 V at the IN+ and IN– input pins, regardless of whether or not the device has power applied at the VS pin. There is no sequencing requirement for V_S and V_{IN+} or V_{IN-} .

10 Layout

10.1 Layout Guidelines

- Connect the input pins to the sensing resistor using a Kelvin or 4-wire connection. This connection technique makes sure that only the current-sensing resistor impedance is detected between the input pins. Poor routing of the current-sensing resistor commonly results in additional resistance present between the input pins. Given the very low ohmic value of the current resistor, any additional high-current carrying impedance can cause significant measurement errors.
- Place the power-supply bypass capacitor as close as possible to the device power supply and ground pins. The recommended value of this bypass capacitor is 0.1 μF . To compensate for noisy or high-impedance power supplies, add more decoupling capacitance.
- When routing the connections from the current-sense resistor to the device, keep the trace lengths as short as possible. Place input filter capacitor C_F as close as possible to the input pins of the device.

10.2 Layout Examples

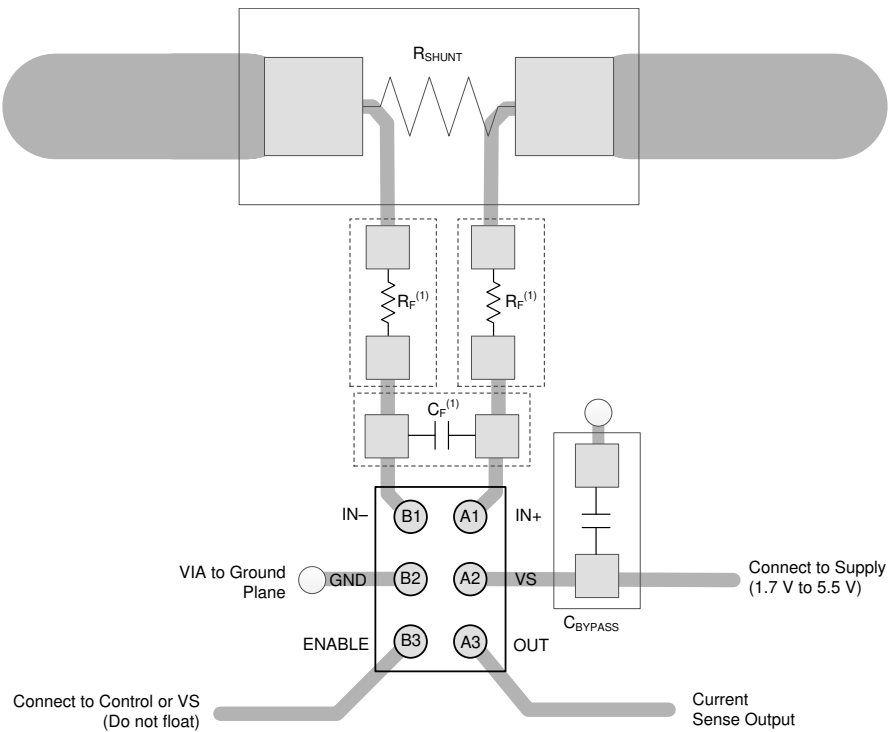

Figure 10-1. Recommended Layout DSBGA (YFD) Package

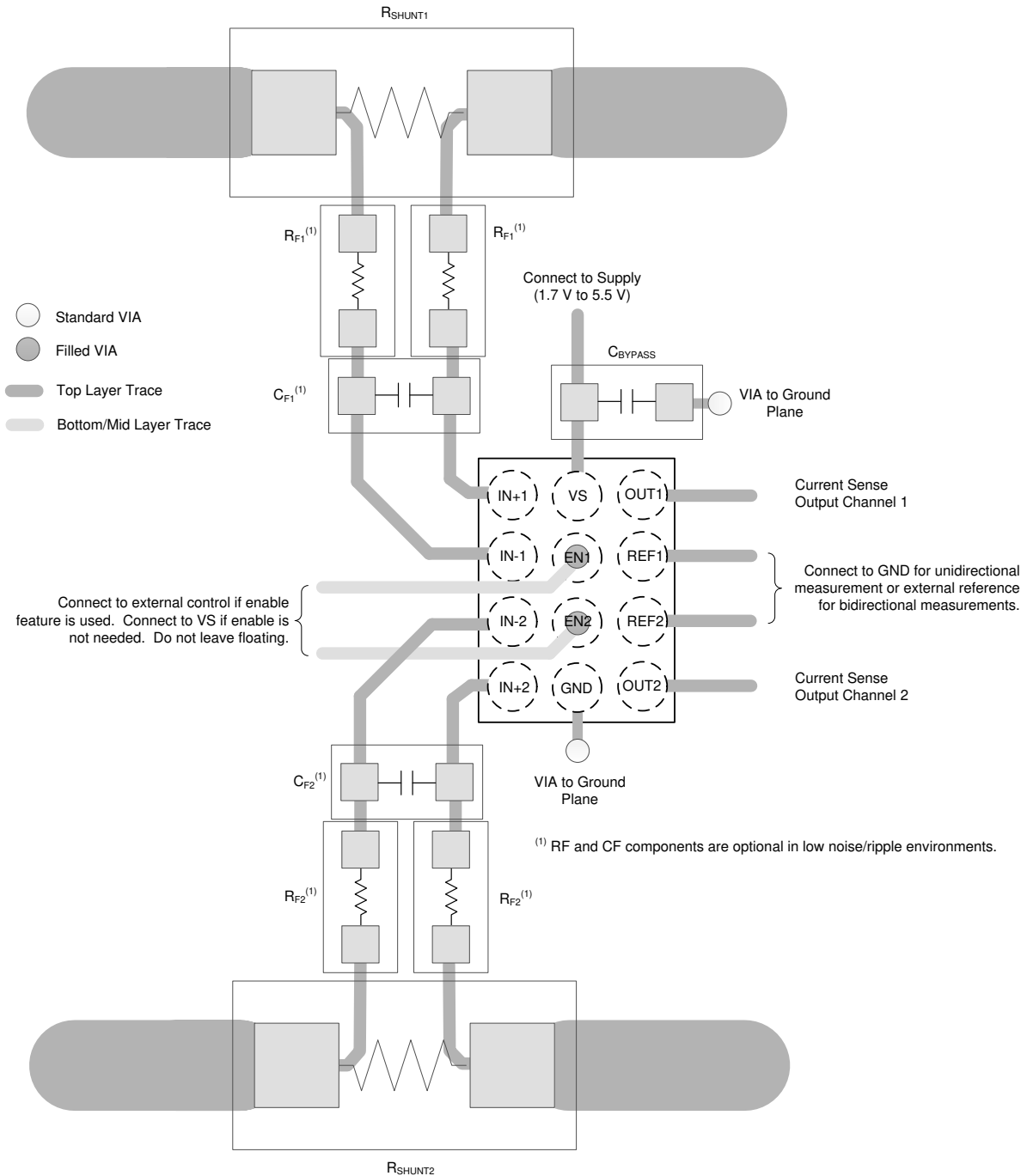

Figure 10-2. Recommended Layout Dual Channel DSBGA (YBJ) Package

11 Device and Documentation Support

11.1 Documentation Support

11.1.1 Related Documentation

For related documentation see the following:

Texas Instruments, [INA191EVM user's guide](#)

11.2 Receiving Notification of Documentation Updates

To receive notification of documentation updates, navigate to the device product folder on [ti.com](#). Click on *Subscribe to updates* to register and receive a weekly digest of any product information that has changed. For change details, review the revision history included in any revised document.

11.3 Support Resources

[TI E2E™ support forums](#) are an engineer's go-to source for fast, verified answers and design help — straight from the experts. Search existing answers or ask your own question to get the quick design help you need.

Linked content is provided "AS IS" by the respective contributors. They do not constitute TI specifications and do not necessarily reflect TI's views; see TI's [Terms of Use](#).

11.4 Trademarks

TI E2E™ is a trademark of Texas Instruments.

All trademarks are the property of their respective owners.

11.5 Electrostatic Discharge Caution



This integrated circuit can be damaged by ESD. Texas Instruments recommends that all integrated circuits be handled with appropriate precautions. Failure to observe proper handling and installation procedures can cause damage.

ESD damage can range from subtle performance degradation to complete device failure. Precision integrated circuits may be more susceptible to damage because very small parametric changes could cause the device not to meet its published specifications.

11.6 Glossary

[TI Glossary](#) This glossary lists and explains terms, acronyms, and definitions.

12 Mechanical, Packaging, and Orderable Information

The following pages include mechanical, packaging, and orderable information. This information is the most current data available for the designated devices. This data is subject to change without notice and revision of this document. For browser-based versions of this data sheet, refer to the left-hand navigation.

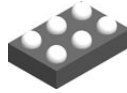

YFD0006-C02

PACKAGE OUTLINE

DSBGA - 0.4 mm max height

DIE SIZE BALL GRID ARRAY

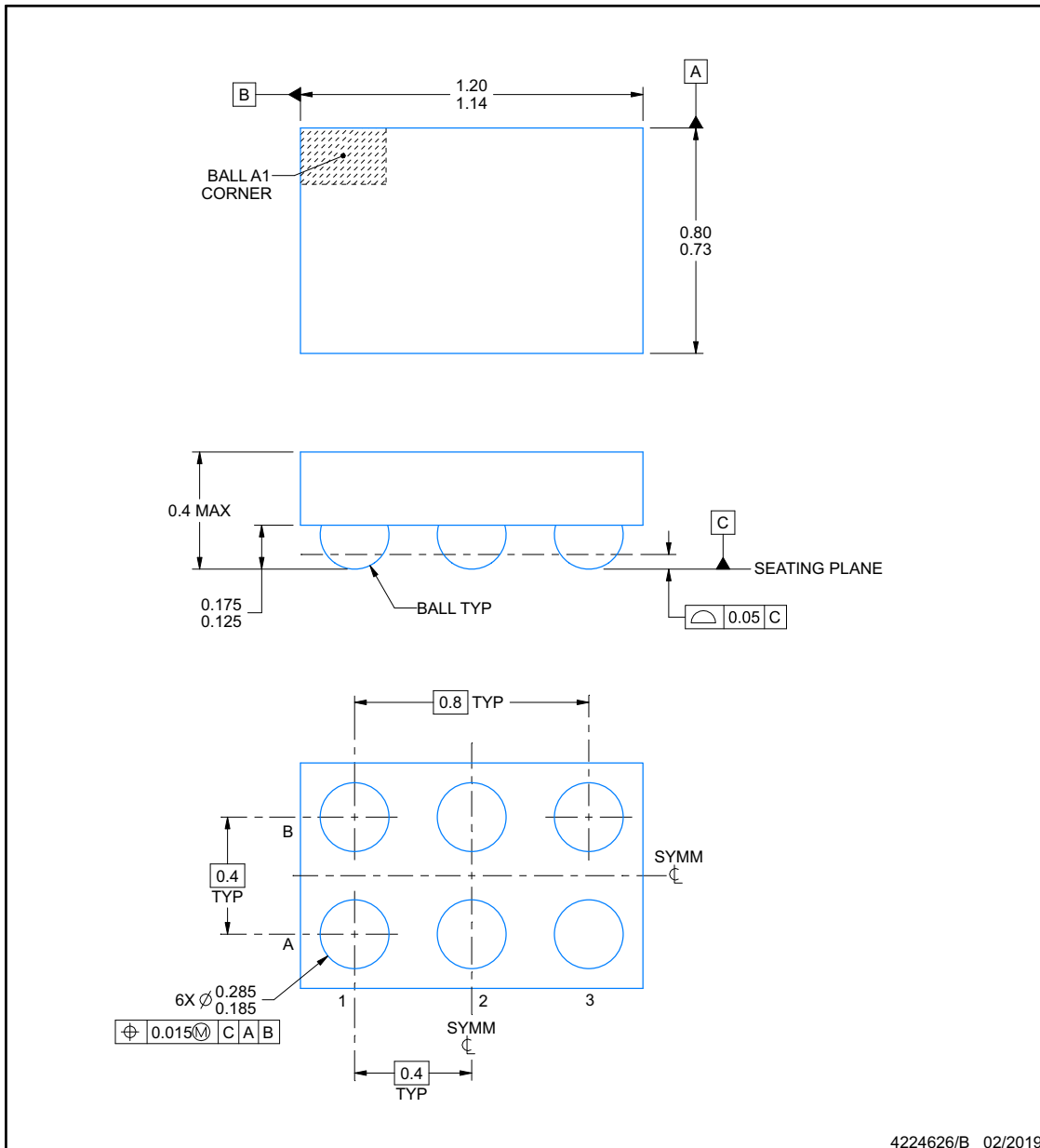

NOTES:

1. All linear dimensions are in millimeters. Any dimensions in parenthesis are for reference only. Dimensioning and tolerancing per ASME Y14.5M.
2. This drawing is subject to change without notice.

EXAMPLE BOARD LAYOUT

YFD0006-C02

DSBGA - 0.4 mm max height

DIE SIZE BALL GRID ARRAY

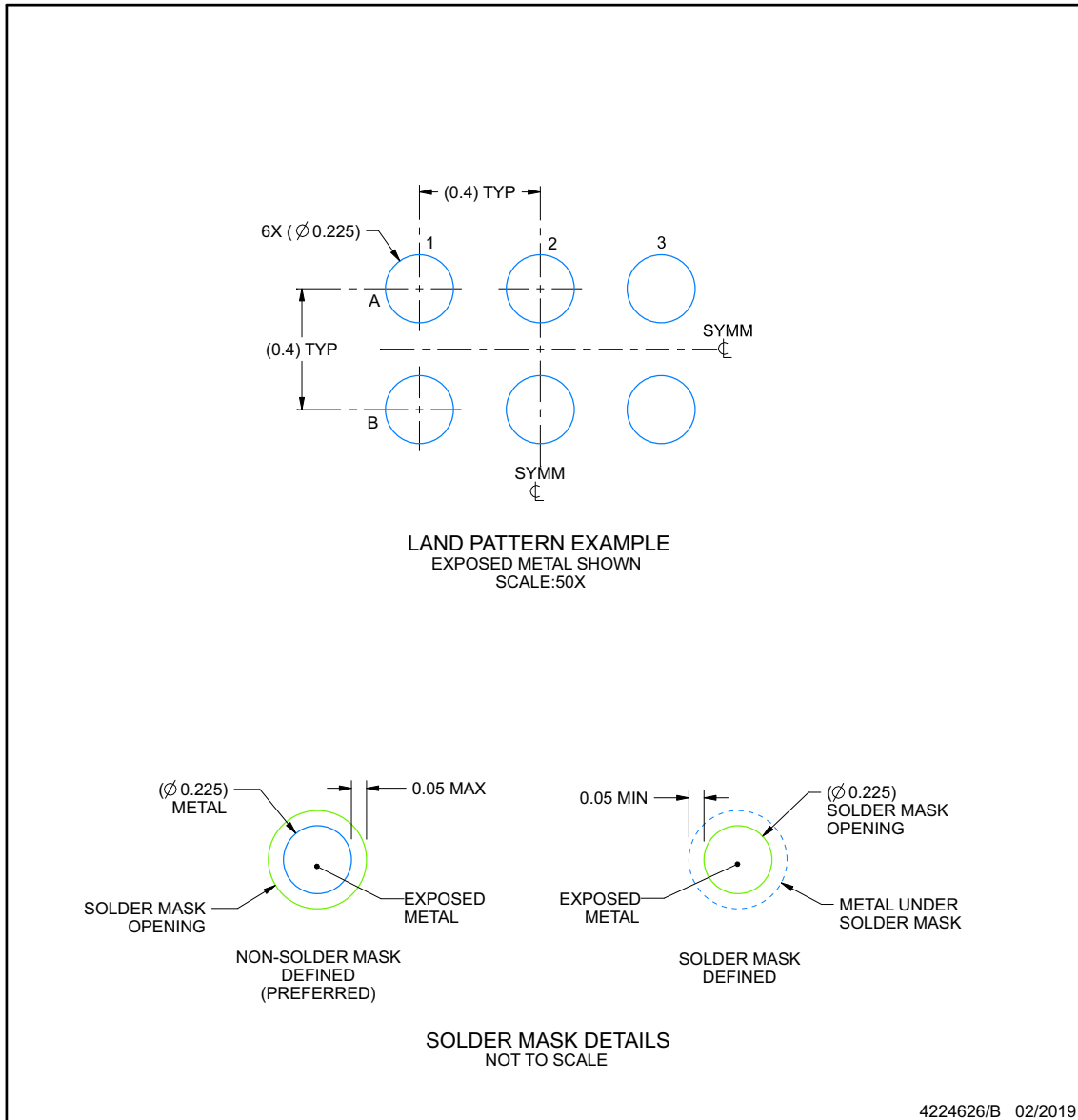

NOTES: (continued)

- Final dimensions may vary due to manufacturing tolerance considerations and also routing constraints. Refer to Texas Instruments Literature No. SNVA009 (www.ti.com/lit/snva009).

EXAMPLE STENCIL DESIGN

YFD0006-C02

DSBGA - 0.4 mm max height

DIE SIZE BALL GRID ARRAY

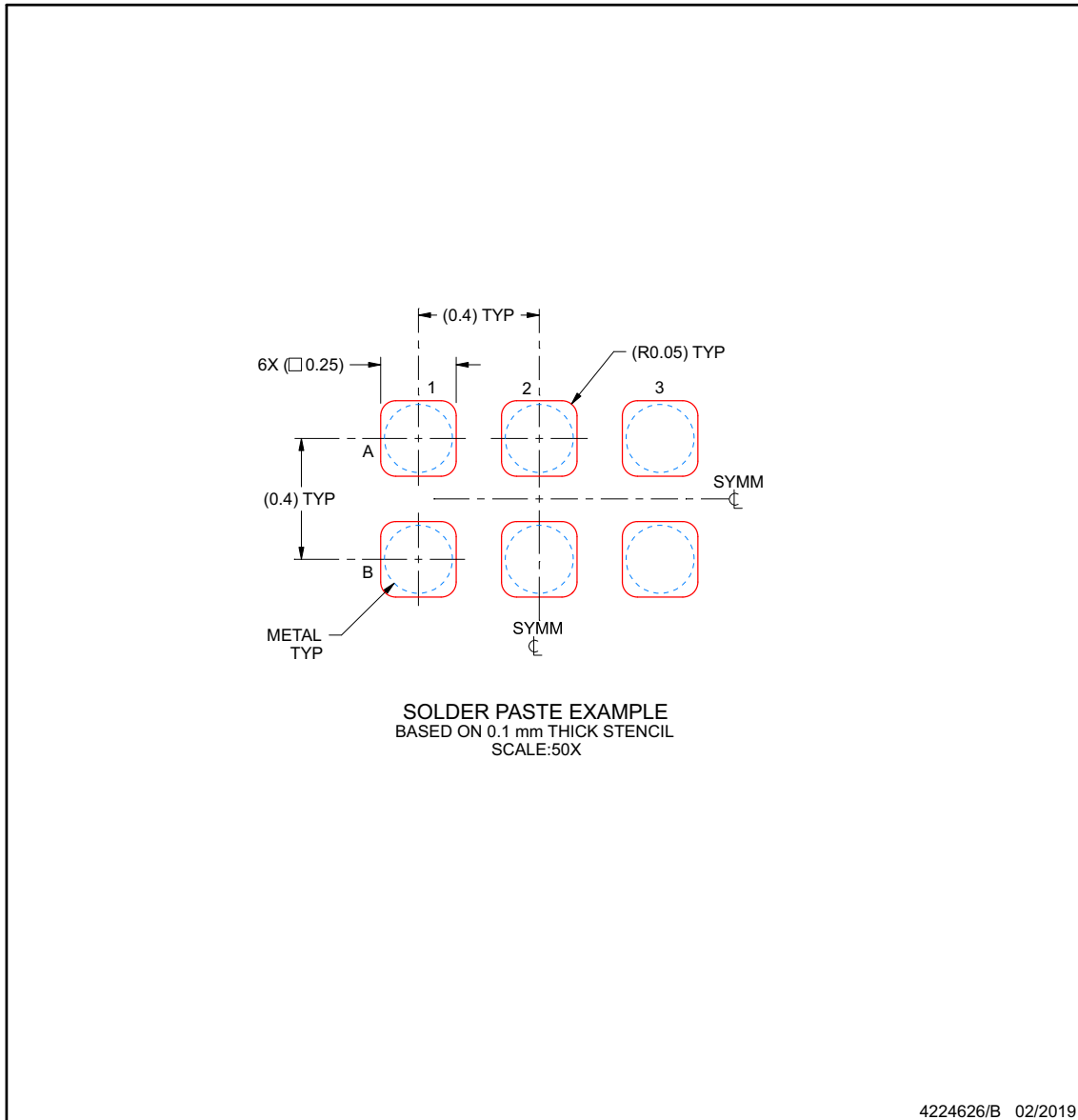

NOTES: (continued)

- 4. Laser cutting apertures with trapezoidal walls and rounded corners may offer better paste release.

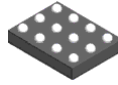

YBJ0012-C01

PACKAGE OUTLINE

DSBGA - 0.35 mm max height

DIE SIZE BALL GRID ARRAY

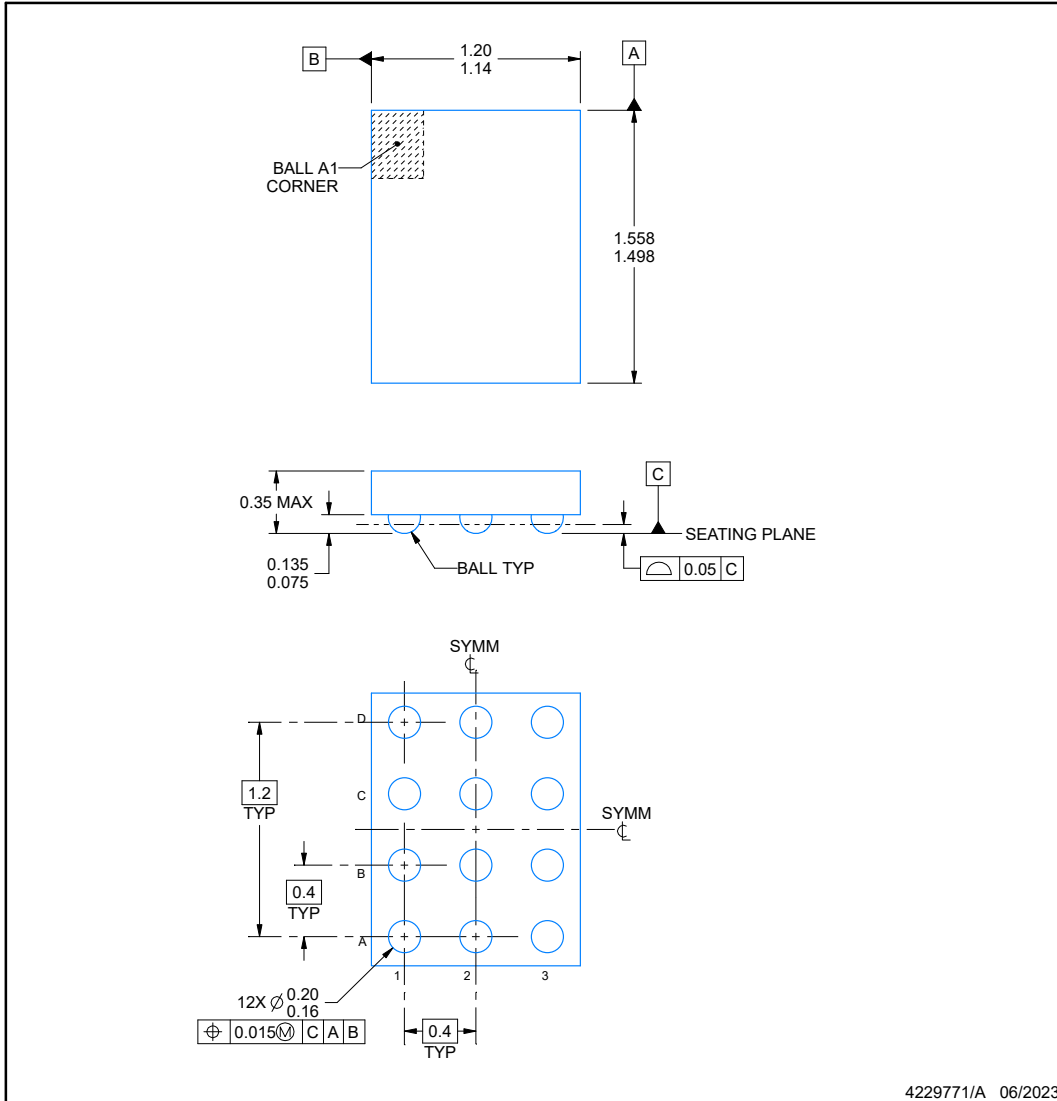

NOTES:

1. All linear dimensions are in millimeters. Any dimensions in parenthesis are for reference only. Dimensioning and tolerancing per ASME Y14.5M.
2. This drawing is subject to change without notice.

EXAMPLE BOARD LAYOUT

YBJ0012-C01

DSBGA - 0.35 mm max height

DIE SIZE BALL GRID ARRAY

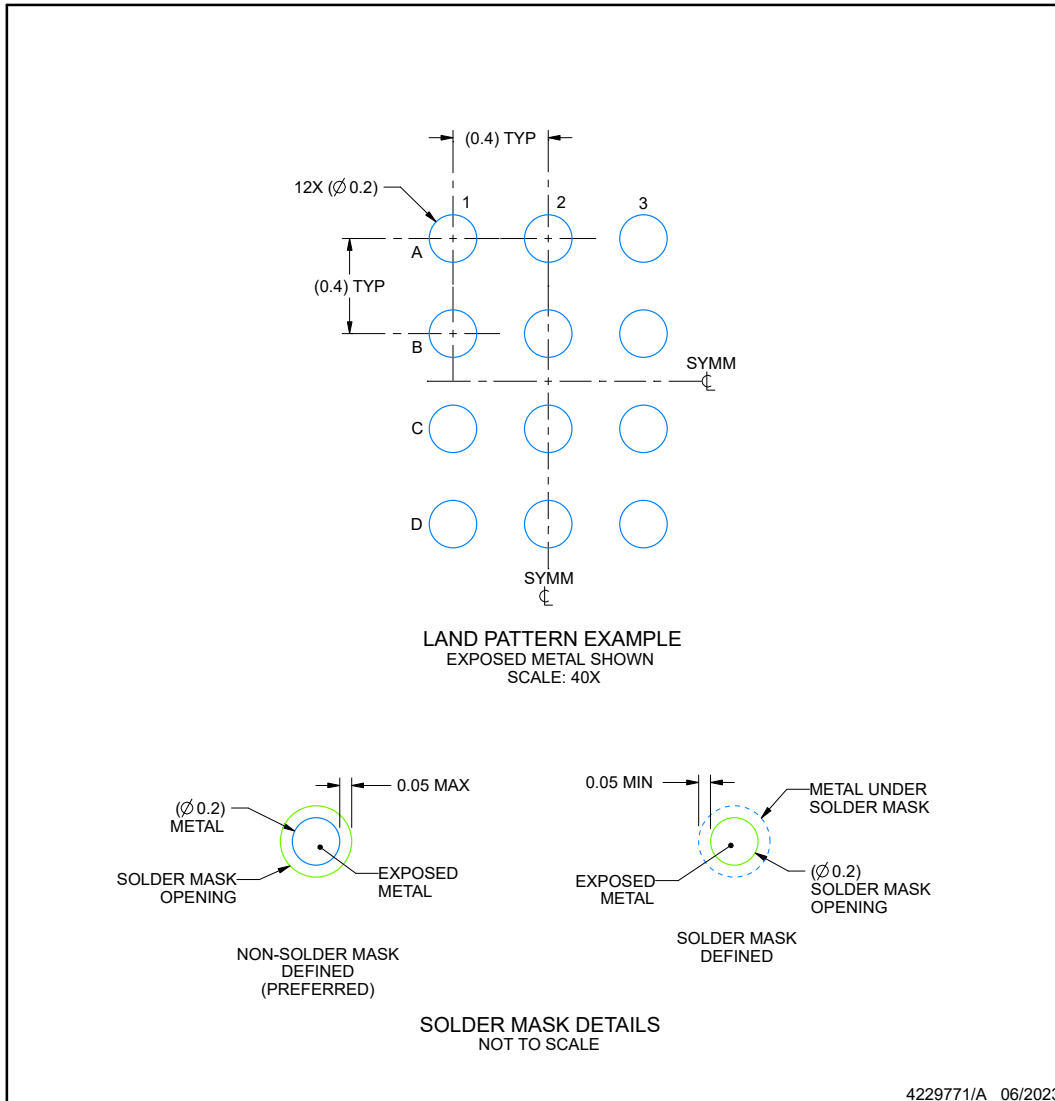

NOTES: (continued)

- Final dimensions may vary due to manufacturing tolerance considerations and also routing constraints. See Texas Instruments Literature No. SNVA009 (www.ti.com/lit/snva009).

EXAMPLE STENCIL DESIGN

YBJ0012-C01

DSBGA - 0.35 mm max height

DIE SIZE BALL GRID ARRAY

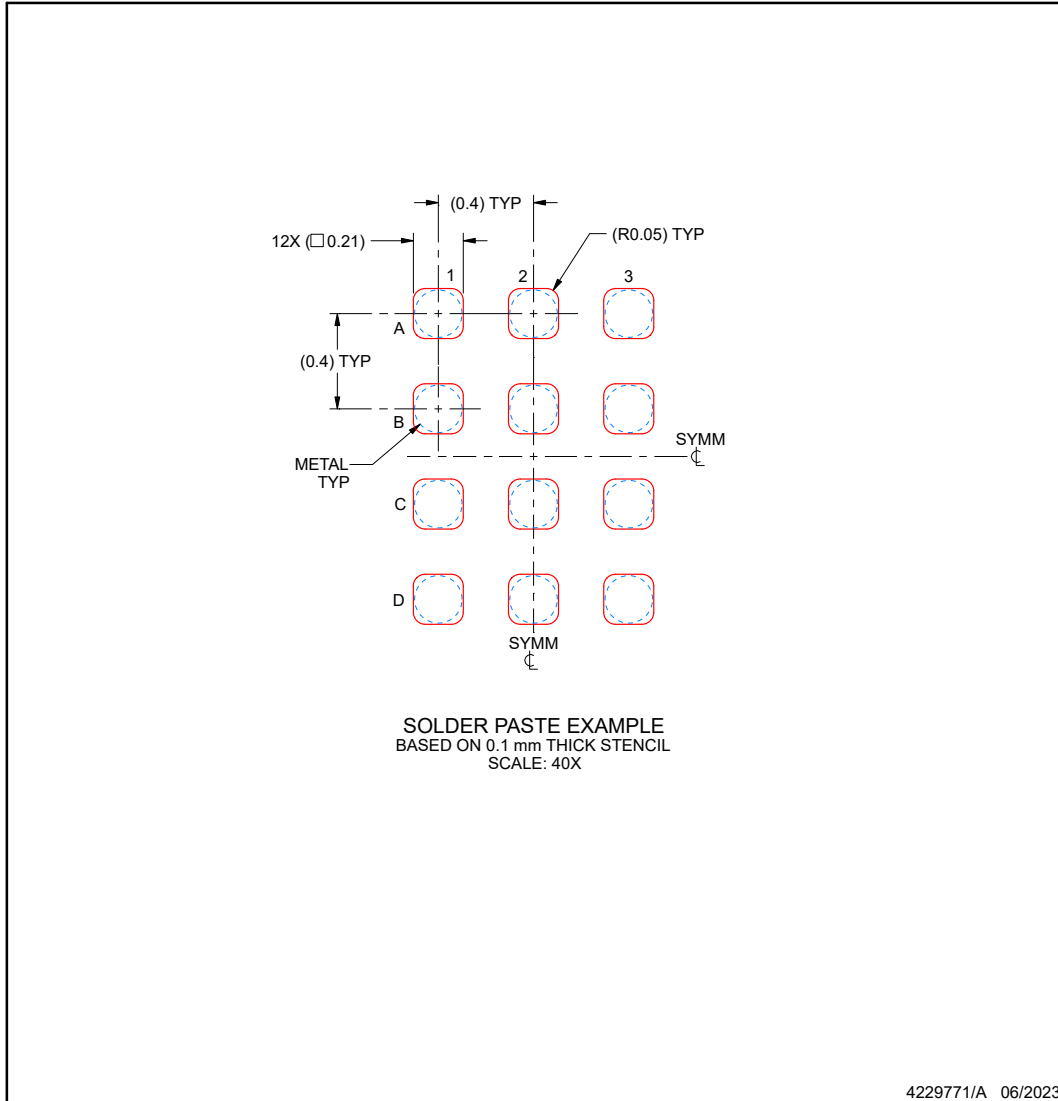

NOTES: (continued)

- 4. Laser cutting apertures with trapezoidal walls and rounded corners may offer better paste release.

PACKAGING INFORMATION

Orderable Device	Status (1)	Package Type	Package Drawing	Pins	Package Qty	Eco Plan (2)	Lead finish/ Ball material (6)	MSL Peak Temp (3)	Op Temp (°C)	Device Marking (4/5)	Samples
INA191A1IYFDR	ACTIVE	DSBGA	YFD	6	3000	RoHS & Green	SNAGCU	Level-1-260C-UNLIM	-40 to 125	1E3	Samples
INA191A2IYFDR	ACTIVE	DSBGA	YFD	6	3000	RoHS & Green	SNAGCU	Level-1-260C-UNLIM	-40 to 125	1E2	Samples
INA191A3IYFDR	ACTIVE	DSBGA	YFD	6	3000	RoHS & Green	SNAGCU	Level-1-260C-UNLIM	-40 to 125	1E4	Samples
INA191A4IYFDR	ACTIVE	DSBGA	YFD	6	3000	RoHS & Green	SNAGCU	Level-1-260C-UNLIM	-40 to 125	1E5	Samples
INA191A5IYFDR	ACTIVE	DSBGA	YFD	6	3000	RoHS & Green	SNAGCU	Level-1-260C-UNLIM	-40 to 125	1E6	Samples
INA2191A1IYBJR	ACTIVE	DSBGA	YBJ	12	3000	RoHS & Green	SAC396	Level-1-260C-UNLIM	-40 to 125	29J1	Samples
INA2191A2IYBJR	ACTIVE	DSBGA	YBJ	12	3000	RoHS & Green	SAC396	Level-1-260C-UNLIM	-40 to 125	29K1	Samples
INA2191A3IYBJR	ACTIVE	DSBGA	YBJ	12	3000	RoHS & Green	SAC396	Level-1-260C-UNLIM	-40 to 125	29L1	Samples
INA2191A4IYBJR	ACTIVE	DSBGA	YBJ	12	3000	RoHS & Green	SAC396	Level-1-260C-UNLIM	-40 to 125	29M1	Samples
INA2191A5IYBJR	ACTIVE	DSBGA	YBJ	12	3000	RoHS & Green	SAC396	Level-1-260C-UNLIM	-40 to 125	29N1	Samples

(1) The marketing status values are defined as follows:

ACTIVE: Product device recommended for new designs.

LIFEBUY: TI has announced that the device will be discontinued, and a lifetime-buy period is in effect.

NRND: Not recommended for new designs. Device is in production to support existing customers, but TI does not recommend using this part in a new design.

PREVIEW: Device has been announced but is not in production. Samples may or may not be available.

OBSOLETE: TI has discontinued the production of the device.

(2) **RoHS:** TI defines "RoHS" to mean semiconductor products that are compliant with the current EU RoHS requirements for all 10 RoHS substances, including the requirement that RoHS substance do not exceed 0.1% by weight in homogeneous materials. Where designed to be soldered at high temperatures, "RoHS" products are suitable for use in specified lead-free processes. TI may reference these types of products as "Pb-Free".

RoHS Exempt: TI defines "RoHS Exempt" to mean products that contain lead but are compliant with EU RoHS pursuant to a specific EU RoHS exemption.

Green: TI defines "Green" to mean the content of Chlorine (Cl) and Bromine (Br) based flame retardants meet JS709B low halogen requirements of <=1000ppm threshold. Antimony trioxide based flame retardants must also meet the <=1000ppm threshold requirement.

(3) MSL, Peak Temp. - The Moisture Sensitivity Level rating according to the JEDEC industry standard classifications, and peak solder temperature.

(4) There may be additional marking, which relates to the logo, the lot trace code information, or the environmental category on the device.

⁽⁵⁾ Multiple Device Markings will be inside parentheses. Only one Device Marking contained in parentheses and separated by a "~" will appear on a device. If a line is indented then it is a continuation of the previous line and the two combined represent the entire Device Marking for that device.

⁽⁶⁾ Lead finish/Ball material - Orderable Devices may have multiple material finish options. Finish options are separated by a vertical ruled line. Lead finish/Ball material values may wrap to two lines if the finish value exceeds the maximum column width.

Important Information and Disclaimer:The information provided on this page represents TI's knowledge and belief as of the date that it is provided. TI bases its knowledge and belief on information provided by third parties, and makes no representation or warranty as to the accuracy of such information. Efforts are underway to better integrate information from third parties. TI has taken and continues to take reasonable steps to provide representative and accurate information but may not have conducted destructive testing or chemical analysis on incoming materials and chemicals. TI and TI suppliers consider certain information to be proprietary, and thus CAS numbers and other limited information may not be available for release.

In no event shall TI's liability arising out of such information exceed the total purchase price of the TI part(s) at issue in this document sold by TI to Customer on an annual basis.

TAPE AND REEL INFORMATION

QUADRANT ASSIGNMENTS FOR PIN 1 ORIENTATION IN TAPE

*All dimensions are nominal

Device	Package Type	Package Drawing	Pins	SPQ	Reel Diameter (mm)	Reel Width W1 (mm)	A0 (mm)	B0 (mm)	K0 (mm)	P1 (mm)	W (mm)	Pin1 Quadrant
INA191A1IYFDR	DSBGA	YFD	6	3000	178.0	8.4	0.84	1.27	0.46	4.0	8.0	Q2
INA191A1IYFDR	DSBGA	YFD	6	3000	180.0	8.4	0.84	1.25	0.5	4.0	8.0	Q2
INA191A2IYFDR	DSBGA	YFD	6	3000	178.0	8.4	0.84	1.27	0.46	4.0	8.0	Q2
INA191A2IYFDR	DSBGA	YFD	6	3000	180.0	8.4	0.84	1.25	0.5	4.0	8.0	Q2
INA191A3IYFDR	DSBGA	YFD	6	3000	180.0	8.4	0.84	1.25	0.5	4.0	8.0	Q2
INA191A3IYFDR	DSBGA	YFD	6	3000	178.0	8.4	0.84	1.27	0.46	4.0	8.0	Q2
INA191A4IYFDR	DSBGA	YFD	6	3000	180.0	8.4	0.84	1.25	0.5	4.0	8.0	Q2
INA191A4IYFDR	DSBGA	YFD	6	3000	178.0	8.4	0.84	1.27	0.46	4.0	8.0	Q2
INA191A5IYFDR	DSBGA	YFD	6	3000	178.0	8.4	0.84	1.27	0.46	4.0	8.0	Q2
INA191A5IYFDR	DSBGA	YFD	6	3000	180.0	8.4	0.84	1.25	0.5	4.0	8.0	Q2
INA2191A1IYBJR	DSBGA	YBJ	12	3000	180.0	8.4	1.3	1.66	0.47	4.0	8.0	Q1
INA2191A2IYBJR	DSBGA	YBJ	12	3000	180.0	8.4	1.3	1.66	0.47	4.0	8.0	Q1
INA2191A3IYBJR	DSBGA	YBJ	12	3000	180.0	8.4	1.3	1.66	0.47	4.0	8.0	Q1
INA2191A4IYBJR	DSBGA	YBJ	12	3000	180.0	8.4	1.3	1.66	0.47	4.0	8.0	Q1
INA2191A5IYBJR	DSBGA	YBJ	12	3000	180.0	8.4	1.3	1.66	0.47	4.0	8.0	Q1

TAPE AND REEL BOX DIMENSIONS



*All dimensions are nominal

Device	Package Type	Package Drawing	Pins	SPQ	Length (mm)	Width (mm)	Height (mm)
INA191A11YFDR	DSBGA	YFD	6	3000	220.0	220.0	35.0
INA191A11YFDR	DSBGA	YFD	6	3000	182.0	182.0	20.0
INA191A21YFDR	DSBGA	YFD	6	3000	220.0	220.0	35.0
INA191A21YFDR	DSBGA	YFD	6	3000	182.0	182.0	20.0
INA191A31YFDR	DSBGA	YFD	6	3000	182.0	182.0	20.0
INA191A31YFDR	DSBGA	YFD	6	3000	220.0	220.0	35.0
INA191A41YFDR	DSBGA	YFD	6	3000	182.0	182.0	20.0
INA191A41YFDR	DSBGA	YFD	6	3000	220.0	220.0	35.0
INA191A51YFDR	DSBGA	YFD	6	3000	220.0	220.0	35.0
INA191A51YFDR	DSBGA	YFD	6	3000	182.0	182.0	20.0
INA2191A11YBJR	DSBGA	YBJ	12	3000	182.0	182.0	20.0
INA2191A21YBJR	DSBGA	YBJ	12	3000	182.0	182.0	20.0
INA2191A31YBJR	DSBGA	YBJ	12	3000	182.0	182.0	20.0
INA2191A41YBJR	DSBGA	YBJ	12	3000	182.0	182.0	20.0
INA2191A51YBJR	DSBGA	YBJ	12	3000	182.0	182.0	20.0

IMPORTANT NOTICE AND DISCLAIMER

TI PROVIDES TECHNICAL AND RELIABILITY DATA (INCLUDING DATA SHEETS), DESIGN RESOURCES (INCLUDING REFERENCE DESIGNS), APPLICATION OR OTHER DESIGN ADVICE, WEB TOOLS, SAFETY INFORMATION, AND OTHER RESOURCES "AS IS" AND WITH ALL FAULTS, AND DISCLAIMS ALL WARRANTIES, EXPRESS AND IMPLIED, INCLUDING WITHOUT LIMITATION ANY IMPLIED WARRANTIES OF MERCHANTABILITY, FITNESS FOR A PARTICULAR PURPOSE OR NON-INFRINGEMENT OF THIRD PARTY INTELLECTUAL PROPERTY RIGHTS.

These resources are intended for skilled developers designing with TI products. You are solely responsible for (1) selecting the appropriate TI products for your application, (2) designing, validating and testing your application, and (3) ensuring your application meets applicable standards, and any other safety, security, regulatory or other requirements.

These resources are subject to change without notice. TI grants you permission to use these resources only for development of an application that uses the TI products described in the resource. Other reproduction and display of these resources is prohibited. No license is granted to any other TI intellectual property right or to any third party intellectual property right. TI disclaims responsibility for, and you will fully indemnify TI and its representatives against, any claims, damages, costs, losses, and liabilities arising out of your use of these resources.

TI's products are provided subject to [TI's Terms of Sale](#) or other applicable terms available either on [ti.com](https://www.ti.com) or provided in conjunction with such TI products. TI's provision of these resources does not expand or otherwise alter TI's applicable warranties or warranty disclaimers for TI products.

TI objects to and rejects any additional or different terms you may have proposed.

Mailing Address: Texas Instruments, Post Office Box 655303, Dallas, Texas 75265
Copyright © 2024, Texas Instruments Incorporated