

INA253 High Voltage, Bidirectional, Zero-Drift, Current-Shunt Monitor With Integrated, 2-m Ω , Precision, Low Inductive Shunt Resistor

1 Features

- Precision Integrated Shunt Resistor
 - Shunt Resistor: 2 m Ω
 - Shunt Inductance: 3 nH
 - Shunt Resistor Tolerance: 0.1% (Max)
 - ± 15 A Continuous from -40°C to $+85^{\circ}\text{C}$
 - 0°C to 125°C Temperature Coefficient: 10 ppm/ $^{\circ}\text{C}$
- High Bandwidth: 350 kHz
- Enhanced PWM rejection
- Excellent CMRR
 - > 120-dB DC CMRR
 - 90-dB AC CMRR at 50 kHz
- Accuracy:
 - Gain:
 - Gain Error: 0.4% (Max)
 - Gain Drift: 45 ppm/ $^{\circ}\text{C}$ (Max)
 - Offset:
 - Offset Current: ± 15 mA (Max)
 - Offset Drift: 125 $\mu\text{A}/^{\circ}\text{C}$ (Max)
- Wide Common-Mode Range: -4 V to $+80$ V
- Available Gains: 100 mV/A, 200 mV/A, and 400 mV/A
- Quiescent Current: 2.4 mA (Max)

2 Applications

- Solenoid and Valve Controls
- Transmission control
- Motor Controls
- Actuator Controls
- DC/DC Converters
- Remote I/O Link Control

3 Description

The INA253 is a voltage-output, current sense amplifier with an integrated shunt resistor of 2 m Ω . The INA253 is designed to monitor bidirectional currents over a wide common-mode range from -4 V to $+80$ V, independent of the supply voltage. Three fixed gains are available: 100 mV/A, 200 mV/A, and 400 mV/A. The integration of the precision resistor with a zero-drift chopped amplifier provides calibration equivalent measurement accuracy, ultra-low temperature drift performance of 15 ppm/ $^{\circ}\text{C}$, and an optimized Kelvin layout for the sensing resistor.

The INA253 is designed with enhanced PWM rejection circuitry to suppress large (dv/dt) signals that enable real-time continuous current measurements. The measurements are critical for in-line current measurements in a motor-drive application, and for solenoid valve control applications.

This device operates from a single 2.7-V to 5.5-V power supply, drawing a maximum of 3 mA of supply current. All gain versions are specified over the extended operating temperature range (-40°C to $+125^{\circ}\text{C}$), and are available in a 20-pin TSSOP package.

Device Information⁽¹⁾

PART NUMBER	PACKAGE	BODY SIZE (NOM)
INA253	TSSOP (20)	6.50 mm x 4.40 mm

(1) For all available packages, see the package option addendum at the end of the data sheet.

Typical Application

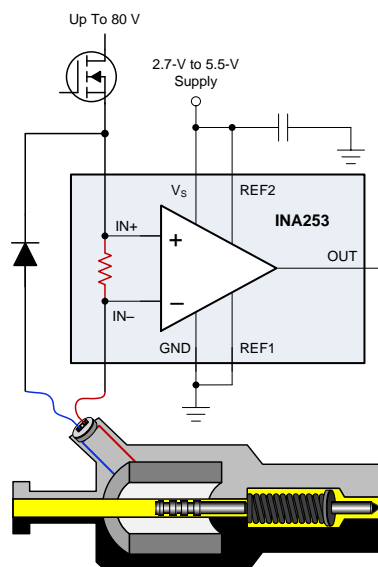

Table of Contents

1 Features	1	8.4 Device Functional Modes.....	16
2 Applications	1	9 Application and Implementation	19
3 Description	1	9.1 Application Information.....	19
4 Revision History	2	9.2 Typical Applications	21
5 Device Comparison Table	3	10 Power Supply Recommendations	27
6 Pin Configuration and Functions	3	11 Layout	27
7 Specifications	4	11.1 Layout Guidelines	27
7.1 Absolute Maximum Ratings	4	11.2 Layout Example	27
7.2 ESD Ratings.....	4	12 Device and Documentation Support	28
7.3 Recommended Operating Conditions	4	12.1 Device Support.....	28
7.4 Thermal Information	4	12.2 Related Documentation	28
7.5 Electrical Characteristics.....	5	12.3 Receiving Notification of Documentation Updates	28
7.6 Typical Characteristics.....	7	12.4 Community Resources.....	28
8 Detailed Description	12	12.5 Trademarks	28
8.1 Overview	12	12.6 Electrostatic Discharge Caution.....	28
8.2 Functional Block Diagram	12	12.7 Glossary	28
8.3 Feature Description.....	12	13 Mechanical, Packaging, and Orderable Information	28

4 Revision History

Changes from Original (July 2018) to Revision A

Page

• Changed device status from advanced information to production data (active)	1
---	----------

5 Device Comparison Table

PRODUCT	GAIN (mV/A)
INA253A1	100
INA253A2	200
INA253A3	400

6 Pin Configuration and Functions

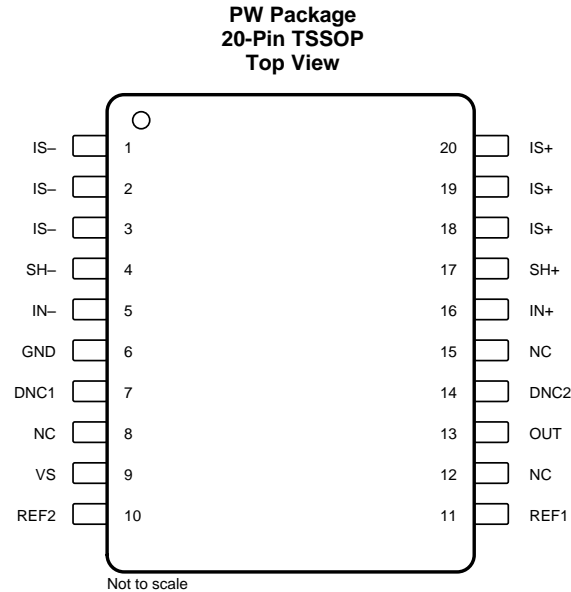

Pin Functions

PIN		I/O	DESCRIPTION
NO.	NAME		
1	IS-	Analog input	Connect to load
2	IS-	Analog input	Connect to load
3	IS-	Analog input	Connect to load
4	SH-	Analog output	Kelvin connection to internal shunt. Connect to IN- if no filtering is needed
5	IN-	Analog input	Voltage input from load side of shunt resistor
6	GND	—	Ground
7	DNC1	—	Do not connect this pin to any potential; leave this pin floating.
8	NC	—	No connect
9	VS	Analog	Power supply, 2.7 V to 5.5 V
10	REF2	Analog input	Reference voltage 2, 0 V to VS
11	REF1	Analog input	Reference voltage 1, 0 V to VS
12	NC	—	No connect
13	OUT	Analog	Output voltage
14	DNC2	—	Do not connect this pin to any potential; leave this pin floating.
15	NC	Analog	Reserved; connect this pin to ground
16	IN+	Analog input	Voltage input from supply side of shunt resistor
17	SH+	Analog output	Kelvin connection to internal shunt. Connect to IN+ if no filtering is needed
18	IS+	Analog input	Connect to supply
19	IS+	Analog input	Connect to supply
20	IS+	Analog input	Connect to supply

7 Specifications

7.1 Absolute Maximum Ratings

over operating free-air temperature range (unless otherwise noted)⁽¹⁾

		MIN	MAX	UNIT
Supply voltage			6	V
Shunt input current (I_{SENSE})	Continuous		±15	A
Analog inputs (IS+, IS–)	Common-mode	GND – 6	90	V
Analog inputs (V_{IN+}, V_{IN-})	Differential ($V_{IN+} - V_{IN-}$)	–80	80	V
	Common-mode	GND – 6	90	V
Analog inputs (REF1, REF2, NC)		GND – 0.3	$V_S + 0.3$	V
Analog outputs (SH+, SH–)	Common-mode	GND – 6	90	V
Analog output (OUT)		GND – 0.3	$V_S + 0.3$	V
Temperature	Operating, T_A	–55	150	°C
	Junction, T_J		150	
	Storage, T_{stg}	–65	150	°C

(1) Stresses beyond those listed under *Absolute Maximum Ratings* may cause permanent damage to the device. These are stress ratings only, which do not imply functional operation of the device at these or any other conditions beyond those indicated under *Recommended Operating Conditions*. Exposure to absolute-maximum-rated conditions for extended periods may affect device reliability.

7.2 ESD Ratings

			VALUE	UNIT
V_{ESD}	Electrostatic discharge	Human-body model (HBM), per ANSI/ESDA/JEDEC JS-001 ⁽¹⁾	±2000	V
		Charged-device model (CDM), per JEDEC specification JESD22-C101 ⁽²⁾	±1000	

(1) JEDEC document JEP155 states that 500-V HBM allows safe manufacturing with a standard ESD control process.

(2) JEDEC document JEP157 states that 250-V CDM allows safe manufacturing with a standard ESD control process.

7.3 Recommended Operating Conditions

over operating free-air temperature range (unless otherwise noted)

		MIN	NOM	MAX	UNIT
V_{CM}	Common-mode input voltage	–4		80	V
V_S	Operating supply voltage	2.7		5.5	V
T_A	Operating free-air temperature	–40		125	°C

7.4 Thermal Information

THERMAL METRIC ⁽¹⁾		INA253	UNIT
		PW (TSSOP)	
		20 PINS	
$R_{\theta JA}$	Junction-to-ambient thermal resistance	110.6	°C/W
$R_{\theta JC(top)}$	Junction-to-case (top) thermal resistance	54.1	°C/W
$R_{\theta JB}$	Junction-to-board thermal resistance	87.5	°C/W
Ψ_{JT}	Junction-to-top characterization parameter	114.1	°C/W
Ψ_{JB}	Junction-to-board characterization parameter	87.5	°C/W

(1) For more information about traditional and new thermal metrics, see the [Semiconductor and IC Package Thermal Metrics](#) application report.

7.5 Electrical Characteristics

at $T_A = 25^\circ\text{C}$, $V_S = 5\text{ V}$, $I_{\text{SENSE}} = I_{\text{S+}} = 0\text{ A}$, $V_{\text{CM}} = 12\text{ V}$, and $V_{\text{REF1}} = V_{\text{REF2}} = V_S / 2$ (unless otherwise noted)

PARAMETER		TEST CONDITIONS	MIN	TYP	MAX	UNIT	
INPUT							
V_{CM}	Common-mode input range	$V_{\text{IN+}} = -4\text{ V to }+80\text{ V}$, $I_{\text{SENSE}} = 0\text{ A}$, $T_A = -40^\circ\text{C to }+125^\circ\text{C}$	-4		80	V	
CMR	Common-mode rejection	$V_{\text{IN+}} = -4\text{ V to }+80\text{ V}$, $I_{\text{SENSE}} = 0\text{ A}$, $T_A = -40^\circ\text{C to }+125^\circ\text{C}$		± 125	± 500	$\mu\text{A/V}$	
		$f = 50\text{ kHz}$		± 13		mA/V	
I_{OS}	Offset current, input-referred	$I_{\text{SENSE}} = 0\text{ A}$		± 2.5	± 15	mA	
dI_{OS}/dT	Offset current drift	$I_{\text{SENSE}} = 0\text{ A}$, $T_A = -40^\circ\text{C to }+125^\circ\text{C}$		25	125	$\mu\text{A}/^\circ\text{C}$	
PSRR	Power-supply rejection ratio	$V_S = 2.7\text{ V to }5.5\text{ V}$, $I_{\text{SENSE}} = 0\text{ A}$		± 0.5	± 5	mA/V	
I_{B}	Input bias current	$I_{\text{B+}}$, $I_{\text{B-}}$, $I_{\text{SENSE}} = 0\text{ A}$		90		μA	
	Reference input range		0		V_S	V	
SHUNT RESISTOR							
R_{SHUNT}	Shunt resistance (SH+ to SH-)	Equivalent resistance when used with onboard amplifier	1.998	2	2.002	$\text{m}\Omega$	
		Used as stand-alone resistor ⁽¹⁾	1.9	2	2.1		
	Package resistance	IS+ to IS-		4.5		$\text{m}\Omega$	
	Package inductance	IS+ to IS-		3		nH	
	Resistor temperature coefficient	$T_A = -40^\circ\text{C to }+125^\circ\text{C}$		15		$\text{ppm}/^\circ\text{C}$	
		$T_A = -40^\circ\text{C to }0^\circ\text{C}$		50			
		$T_A = 0^\circ\text{C to }125^\circ\text{C}$		10		$\text{ppm}/^\circ\text{C}$	
I_{SENSE}	Maximum continuous current ⁽²⁾	$T_A = -40^\circ\text{C to }+85^\circ\text{C}$			± 15	A	
	Shunt short time overload	$I_{\text{SENSE}} = 30\text{ A}$ for 5 seconds		$\pm 0.05\%$			
	Shunt thermal shock	$-65^\circ\text{C to }+150^\circ\text{C}$, 500 cycles		$\pm 0.1\%$			
	Shunt resistance to solder heat	260°C solder, 10 seconds		$\pm 0.1\%$			
	Shunt high temperature exposure	1000 hours, $T_A = 150^\circ\text{C}$		$\pm 0.15\%$			
	Shunt cold temperature storage	24 hours, $T_A = -65^\circ\text{C}$		$\pm 0.025\%$			
	OUTPUT						
	G	Gain	INA253A1		100		mV/A
INA253A2				200			
INA253A3				400		mV/A	
	System gain error ⁽³⁾	$\text{GND} + 50\text{ mV} \leq V_{\text{OUT}} \leq V_S - 200\text{ mV}$, $T_A = 25^\circ\text{C}$		$\pm 0.05\%$	$\pm 0.4\%$		
		$T_A = -40^\circ\text{C to }+125^\circ\text{C}$			± 45	$\text{ppm}/^\circ\text{C}$	
	Nonlinearity error	$\text{GND} + 10\text{ mV} \leq V_{\text{OUT}} \leq V_S - 200\text{ mV}$		$\pm 0.01\%$			
	Reference divider accuracy	$V_{\text{OUT}} = (V_{\text{REF1}} - V_{\text{REF2}}) / 2$ at $I_{\text{SENSE}} = 0\text{ A}$, $T_A = -40^\circ\text{C to }+125^\circ\text{C}$		0.02%	0.1%		
RVRR	Reference voltage rejection ratio (input-referred)	INA253A2		2.5		mA/V	
		INA253A1, INA253A3		1			
	Maximum capacitive load	No sustained oscillation		1		nF	
VOLTAGE OUTPUT							
	Swing to V_S power-supply rail	$R_L = 10\text{ k}\Omega$ to GND, $T_A = -40^\circ\text{C to }+125^\circ\text{C}$		$V_S - 0.05$	$V_S - 0.2$	V	
	Swing to GND	$R_L = 10\text{ k}\Omega$ to GND, $I_{\text{SENSE}} = 0\text{ A}$, $V_{\text{REF1}} = V_{\text{REF2}} = 0\text{ V}$, $T_A = -40^\circ\text{C to }+125^\circ\text{C}$		$V_{\text{GND}} + 1$	$V_{\text{GND}} + 10$	mV	

- (1) The internal shunt resistor is intended to be used with the internal amplifier and is not intended to be used as a stand-alone resistor. See the [Integrated Shunt Resistor](#) section for more information.
- (2) See [Maximum Continuous Current](#) for additional information on the current derating and review [layout](#) recommendations to improve the current handling capability of the device at higher temperatures.
- (3) System gain error includes amplifier gain error and the integrated sense resistor tolerance. System gain error does not include the stress related characteristics of the integrated sense resistor. These characteristics are described in the [Shunt Resistor](#) section of the [Electrical Characteristics](#) table.

Electrical Characteristics (continued)

 at $T_A = 25\text{ }^\circ\text{C}$, $V_S = 5\text{ V}$, $I_{\text{SENSE}} = I_{\text{S}+} = 0\text{ A}$, $V_{\text{CM}} = 12\text{ V}$, and $V_{\text{REF1}} = V_{\text{REF2}} = V_S / 2$ (unless otherwise noted)

PARAMETER		TEST CONDITIONS	MIN	TYP	MAX	UNIT
FREQUENCY RESPONSE						
BW	Bandwidth ⁽⁴⁾	All gains, –3-dB bandwidth		350		kHz
		All gains, 2% THD+N ⁽⁴⁾		100		kHz
	Output settling time	Settles to 0.5% of final value		10		μs
SR	Slew rate			2.4		V/ μs
NOISE (Input Referred)						
	Voltage noise density			40		nV/ $\sqrt{\text{Hz}}$
POWER SUPPLY						
V_S	Operating voltage range	$T_A = -40\text{ }^\circ\text{C}$ to $+125\text{ }^\circ\text{C}$	2.7		5.5	V
I_Q	Quiescent current	$I_{\text{SENSE}} = 0\text{ A}$		1.8	2.4	mA
		I_Q vs temperature, $T_A = -40\text{ }^\circ\text{C}$ to $+125\text{ }^\circ\text{C}$			2.6	

 (4) See [Bandwidth](#) section for more details.

7.6 Typical Characteristics

at $T_A = 25^\circ\text{C}$, $V_S = 5\text{ V}$, $V_{IN+} = 12\text{ V}$, and $V_{REF} = V_S / 2$ (unless otherwise noted)

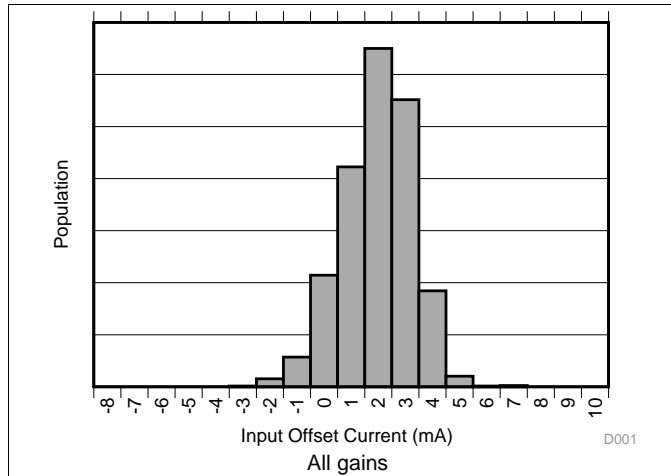

Figure 1. Input Offset Voltage Production Distribution

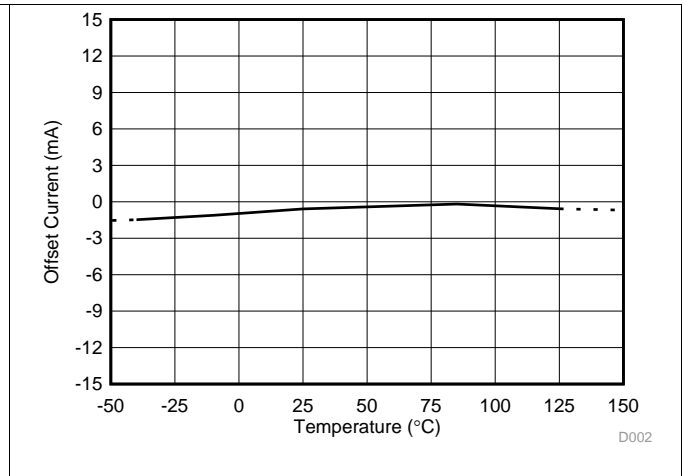

Figure 2. Input Offset Current vs Temperature

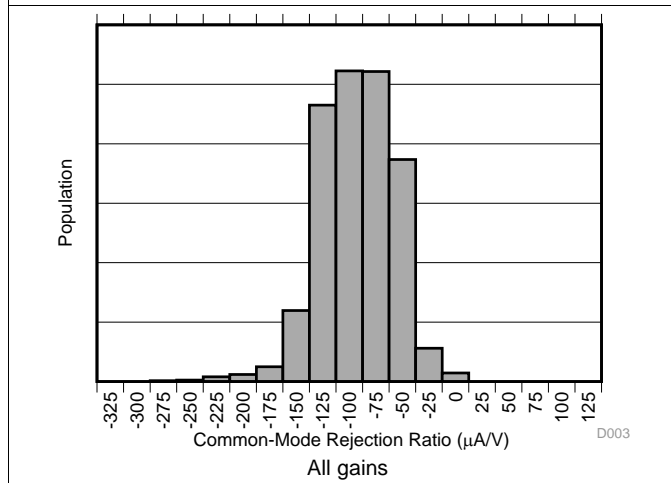

Figure 3. Common-Mode Rejection Production Distribution

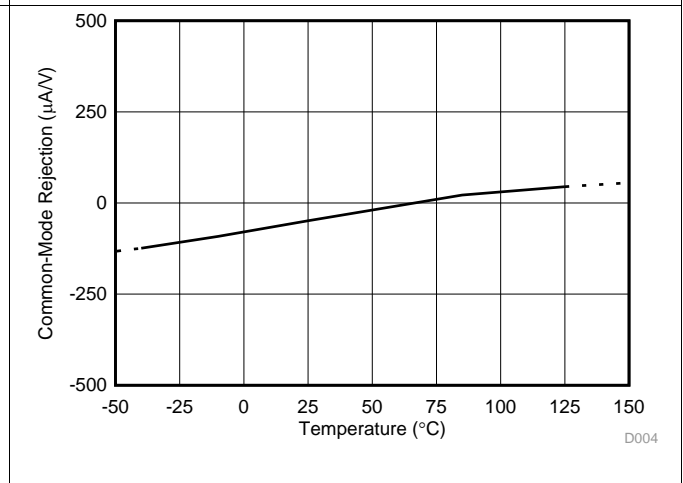

Figure 4. Common-Mode Rejection Ratio vs Temperature

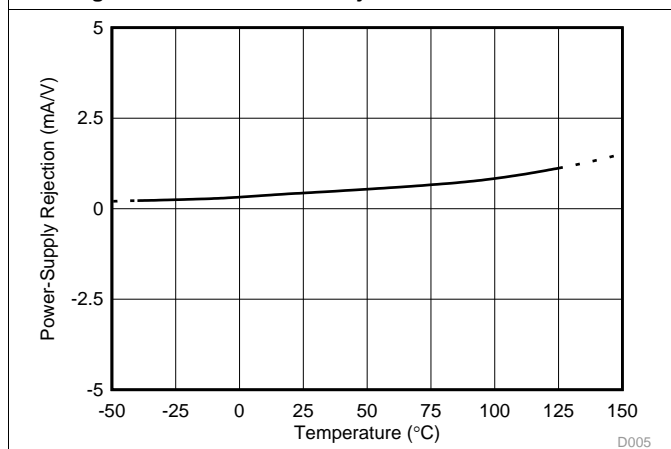

Figure 5. Power-Supply Rejection Ratio vs Temperature

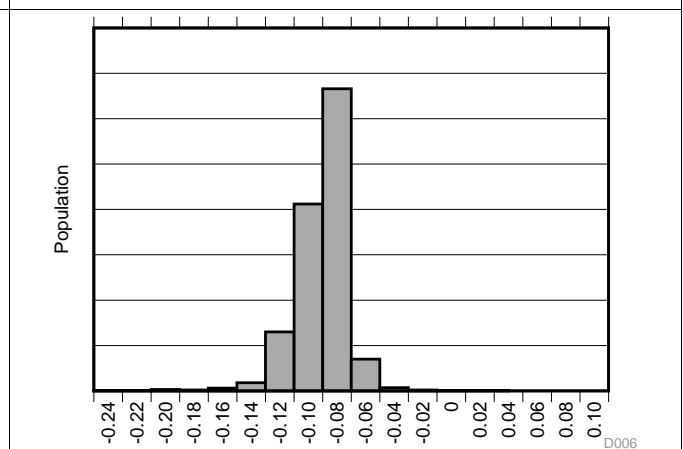
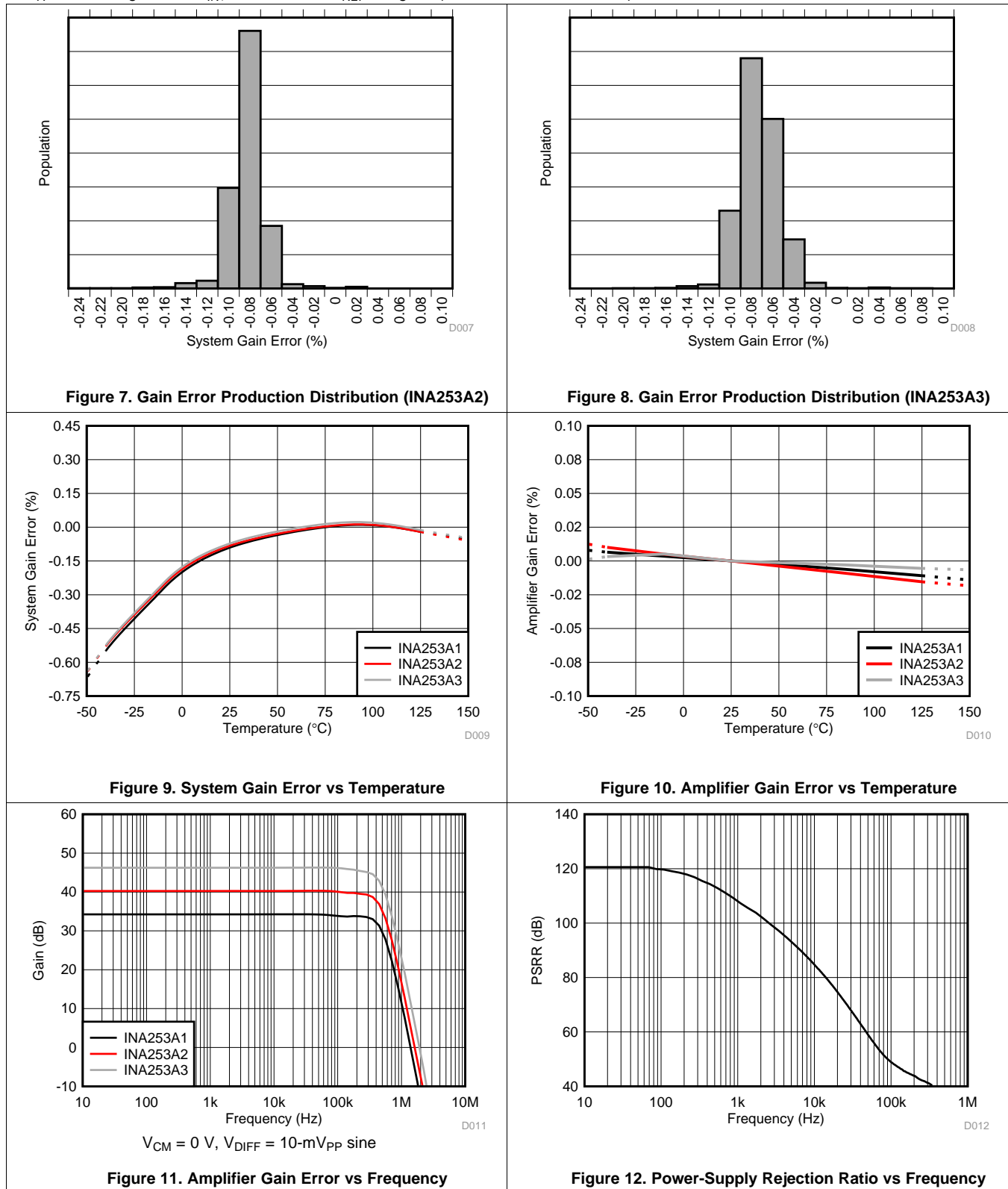

Figure 6. Gain Error Production Distribution (INA253A1)

Typical Characteristics (continued)

at $T_A = 25^\circ\text{C}$, $V_S = 5\text{ V}$, $V_{IN+} = 12\text{ V}$, and $V_{REF} = V_S / 2$ (unless otherwise noted)



Typical Characteristics (continued)

at $T_A = 25^\circ\text{C}$, $V_S = 5\text{ V}$, $V_{IN+} = 12\text{ V}$, and $V_{REF} = V_S / 2$ (unless otherwise noted)

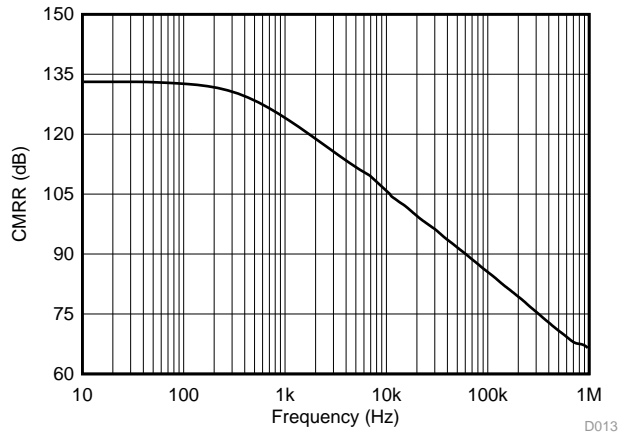

Figure 13. Common-Mode Rejection Ratio vs Frequency

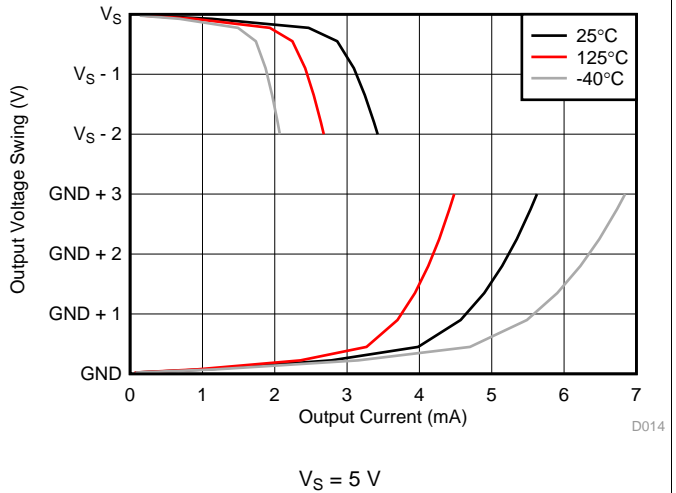

Figure 14. Output Voltage Swing vs Output Current

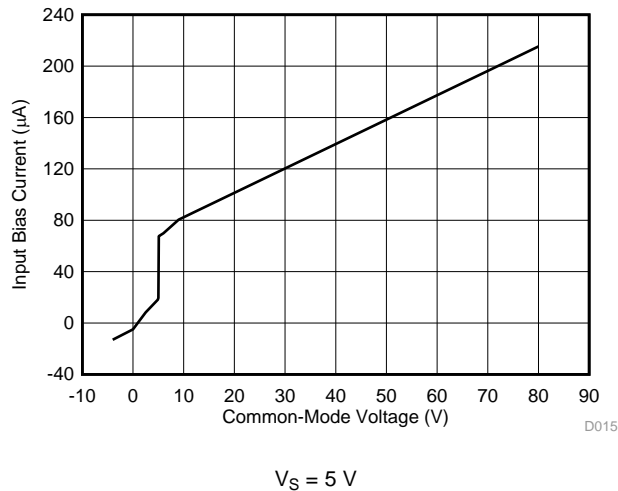

Figure 15. Input Bias Current vs Common-Mode Voltage

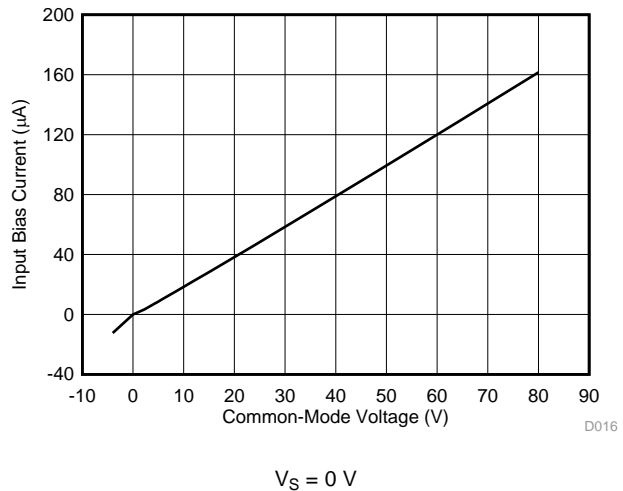

Figure 16. Input Bias Current vs Common-Mode Voltage

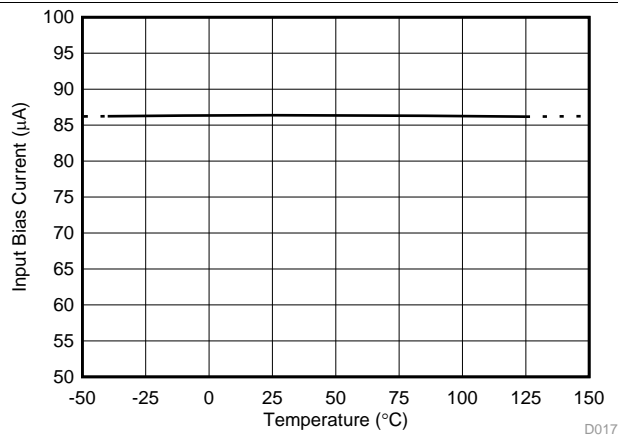

Figure 17. Input Bias Current vs Temperature

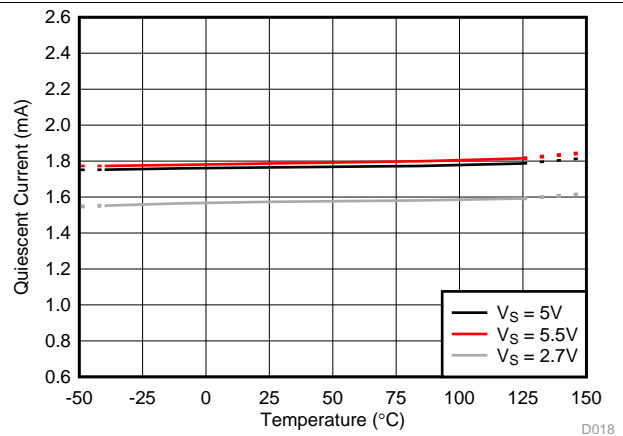

Figure 18. Quiescent Current vs Temperature

Typical Characteristics (continued)

at $T_A = 25^\circ\text{C}$, $V_S = 5\text{ V}$, $V_{IN+} = 12\text{ V}$, and $V_{REF} = V_S / 2$ (unless otherwise noted)

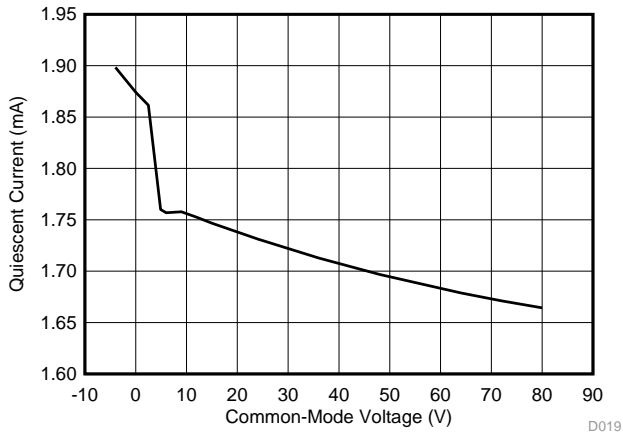

Figure 19. Quiescent Current vs Common-mode Voltage

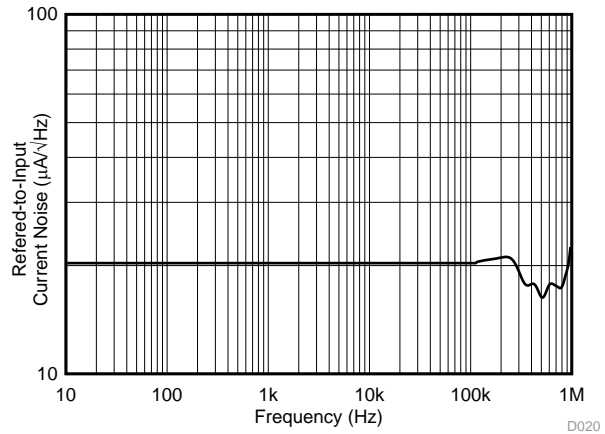

Figure 20. INA253A1 Input-Referred Voltage Noise vs Frequency

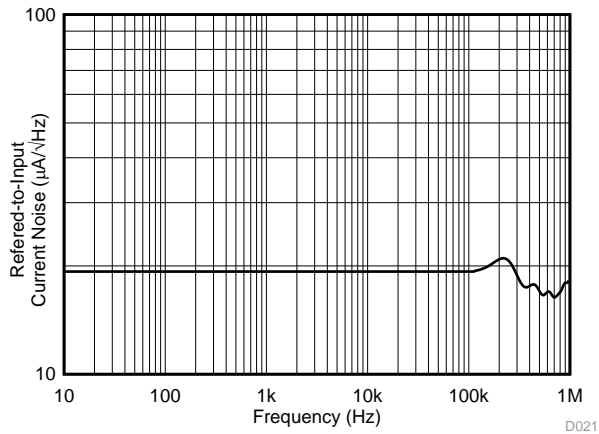

Figure 21. INA253A2 Input-Referred Voltage Noise vs Frequency

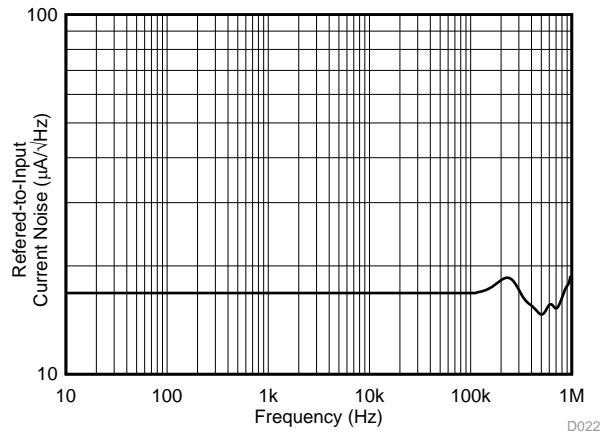

Figure 22. INA253A3 Input-Referred Voltage Noise vs Frequency

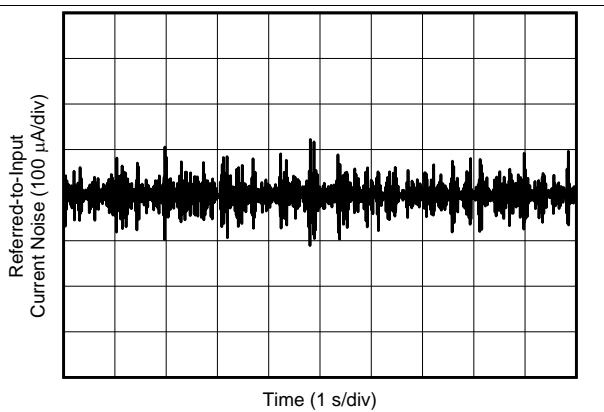
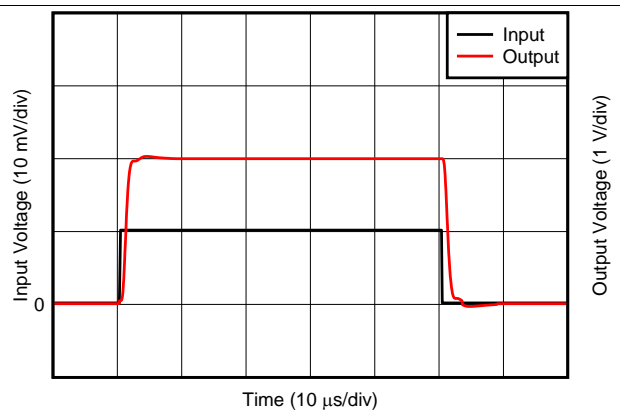

Figure 23. 0.1-Hz to 10-Hz Voltage Noise (Referred-to-Input)



$V_{REF1} = V_{REF2} = 0\text{ V}$, 10-mV_{PP} input step

Figure 24. Amplifier Step Response

Typical Characteristics (continued)

at $T_A = 25^\circ\text{C}$, $V_S = 5\text{ V}$, $V_{IN+} = 12\text{ V}$, and $V_{REF} = V_S / 2$ (unless otherwise noted)

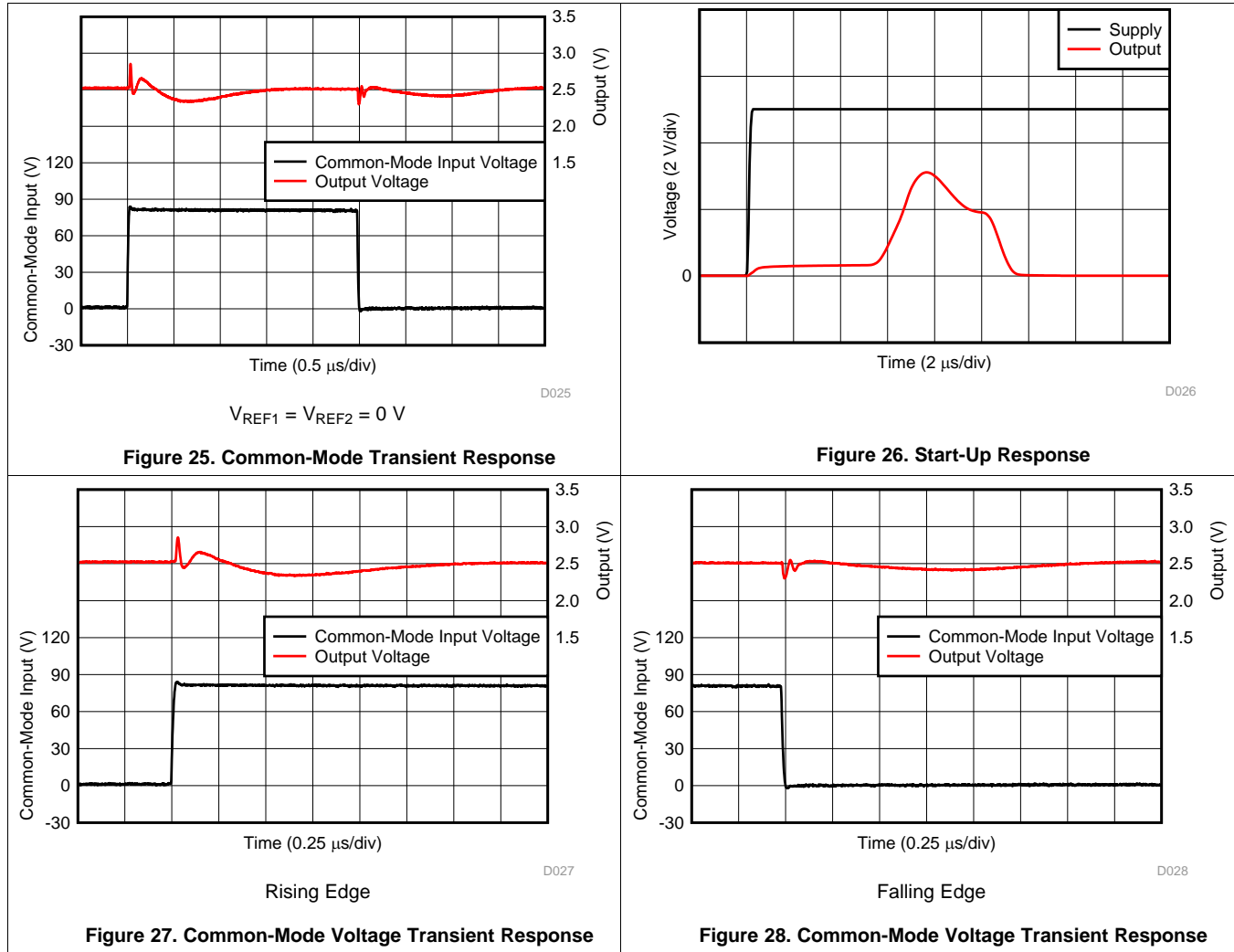

8 Detailed Description

8.1 Overview

The INA253 features a precision, 2-m Ω current-sensing resistor and supports common mode voltages up to 80 V. The internal amplifier features a precision zero-drift topology with excellent common-mode rejection ratio (CMRR). The internal amplifier also features an enhanced pulse-width modulation (PWM) rejection current-sensing amplifier integrated into a single package. High-precision measurements are enabled by matching the shunt resistor value and the current-sensing amplifier gain, thus providing a highly-accurate, system-calibrated method for measuring current. Enhanced PWM rejection reduces the effect of common-mode transients on the output signal that are associated with PWM signals. Multiple gain versions are available to allow for the optimization of the desired full-scale output voltage based on the target current range expected in the application.

8.2 Functional Block Diagram

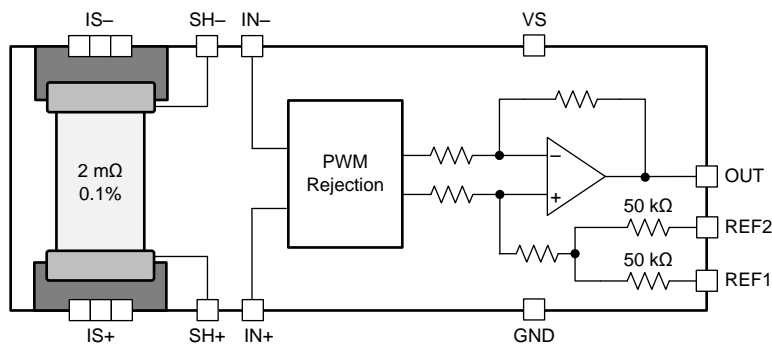

8.3 Feature Description

8.3.1 Integrated Shunt Resistor

The INA253 features a precise, low-drift, current-sensing resistor that provides accurate measurements over the entire specified temperature range of -40°C to $+125^{\circ}\text{C}$. The integrated current-sensing resistor provides measurement stability over temperature, and simplifies printed circuit board (PCB) layout and board constraint difficulties common in high-precision measurements.

The onboard current-sensing resistor is designed as a 4-wire (or Kelvin) connected resistor that enables accurate measurements through a force-sense connection. Connecting the amplifier inputs pins (VIN- and VIN+) to the sense pins of the shunt resistor (SH- and SH+) eliminates many of the parasitic impedances commonly found in typical very-low sensing-resistor level measurements. Although the sense connection of the current-sensing resistor can be accessed through the SH+ and SH- pins, this resistor is not intended to be used as a stand-alone component. The INA253 is system-calibrated to make sure that the current-sensing resistor and current-sensing amplifier are both precisely matched to one another. Use of the shunt resistor without the onboard amplifier results in a current-sensing resistor tolerance of approximately 5%. To achieve the optimized system gain specification, the onboard sensing resistor must be used with the internal current-sensing amplifier.

The INA253 has approximately 4.5 m Ω of package resistance. Of this total package resistance, 2 m Ω is a precisely-controlled resistance from the Kelvin-connected current-sensing resistor used by the amplifier. The power dissipation requirements of the system and package are based on the total 4.5-m Ω package resistance between the IS+ and IS- pins. The heat dissipated across the package when current flows through the device ultimately determines the maximum current that can be safely handled by the package. The current consumption of the silicon is relatively low, leaving the total package resistance to carry the high load current as the primary contributor to the total power dissipation of the package. The maximum safe-operating current level is set to make sure that the heat dissipated across the package is limited so that no damage occurs to the resistor or the package, or that the internal junction temperature of the silicon does not exceed a 150°C limit.

Feature Description (continued)

External factors, such as ambient temperature, external air flow, and PCB layout, contribute to how effectively the device dissipates heat. The internal heat is developed as a result of the current flowing through the total package resistance of 4.5 mΩ. Under the conditions of no air flow, a maximum ambient temperature of 85°C, and 1-oz. copper input power planes, the INA253 accommodates continuous current levels up to 15 A. Figure 29 shows that the current-handling capability is derated at temperatures greater than the 85°C level, with safe operation up to 10 A at a 125°C ambient temperature. With air flow and larger 2-oz. copper input power planes, the INA253 safely accommodates continuous current levels up to 15 A across the entire –40°C to +125°C temperature range.

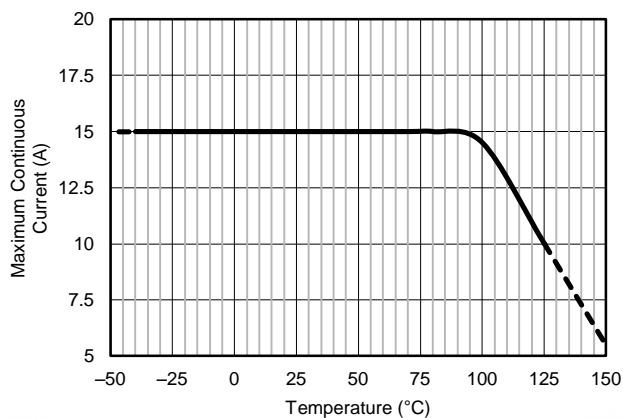

Figure 29. Maximum Continuous Current vs Temperature

8.3.2 Short-Circuit Duration

The INA253 features a physical shunt resistance that is able to withstand current levels higher than the continuous handling limit of 15 A without sustaining damage to the current-sensing resistor or the current-sensing amplifier, if the excursions are brief. Figure 30 shows the short-circuit duration curve for the INA253.

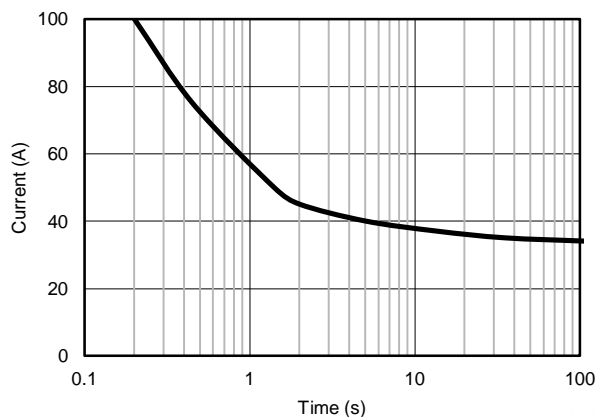

Figure 30. Short-Circuit Duration

Feature Description (continued)

8.3.3 Temperature Stability

System calibration is common for many industrial applications in order to eliminate initial component and system-level errors that can be present. A system-level calibration reduces the initial accuracy requirement for many of the individual components because the errors associated with these components are effectively eliminated through the calibration procedure. This calibration enables precise measurements at the temperature in which the system is calibrated. As the system temperature changes because of external ambient changes or self heating, measurement errors are reintroduced. Without accurate temperature compensation used in addition to the initial adjustment, the calibration procedure is not effective. The user must account for temperature-induced changes. One of the primary benefits of the low temperature coefficient of the INA253 (including both the integrated current-sensing resistor and current-sensing amplifier) is that the device measurement remains accurate, even when the temperature changes throughout the specified temperature range of the device.

Figure 31 shows the drift performance for the integrated current-sensing resistor. Use Figure 31 to determine the typical variance in the shunt resistor value at various temperatures. As with any resistive element, the tolerance of the component varies when exposed to different temperature conditions. For the current-sensing resistor integrated in the INA253, the resistor does vary slightly more when operated in temperatures ranging from -40°C to 0°C than when operated from 0°C to 125°C . Even in the -40°C to 0°C temperature range, the drift is still low at 25 ppm/ $^{\circ}\text{C}$.

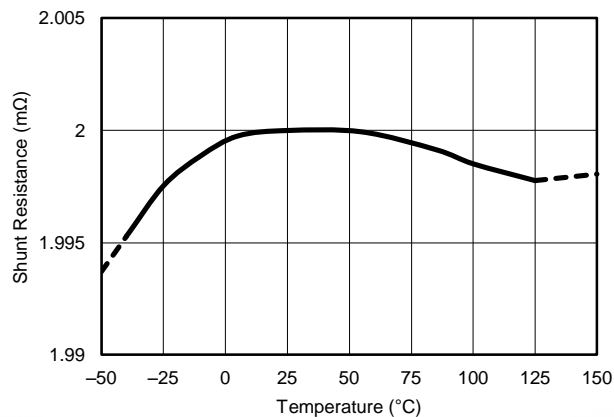

Figure 31. Sensing Resistor vs Temperature

An additional aspect to consider is that when current flows through the current-sensing resistor, power is dissipated across this component. This dissipated power results in an increase in the internal temperature of the package, including the integrated sensing resistor. This resistor self-heating effect results in an increase of the resistor temperature helping to move the component out of the colder, wider drift temperature region.

8.3.4 Enhanced PWM Rejection Operation

The enhanced PWM rejection feature of the INA253 provides increased attenuation of large common-mode $\Delta V/\Delta t$ transients. Large $\Delta V/\Delta t$ common-mode transients associated with PWM signals are employed in applications such as motor or solenoid drive and switching power supplies. Traditionally, large $\Delta V/\Delta t$ common-mode transients are handled strictly by increasing the amplifier signal bandwidth, which can increase chip size, complexity and ultimately cost. The INA253 is designed with high common-mode rejection techniques to reduce large $\Delta V/\Delta t$ transients before the system is disturbed as a result of these large signals. The high ac CMRR, in conjunction with signal bandwidth, allows the INA253 to provide minimal output transients and ringing compared with standard circuit approaches.

Feature Description (continued)

8.3.5 Input Signal Bandwidth

The INA253 input signal, which represents the current being measured, is accurately measured with minimal disturbance from large $\Delta V/\Delta t$ common-mode transients as previously described. For PWM signals typically associated with motors, solenoids, and other switching applications, the current being monitored varies at a significantly slower rate than the faster PWM frequency.

The INA253 bandwidth is defined by the -3 -dB bandwidth of the current-sense amplifier inside the device; see the [Electrical Characteristics](#) for more information. The device bandwidth provides fast throughput and fast response required for the rapid detection and processing of overcurrent events. Without the higher bandwidth, protection circuitry may not have adequate response time, and damage may occur to the monitored application or circuit.

Figure 32 shows the performance profile of the device over frequency. Harmonic distortion increases at the upper end of the amplifier bandwidth with no adverse change in detection of overcurrent events. However, increased distortion at the highest frequencies must be considered when the measured current bandwidth begins to approach the INA253 bandwidth.

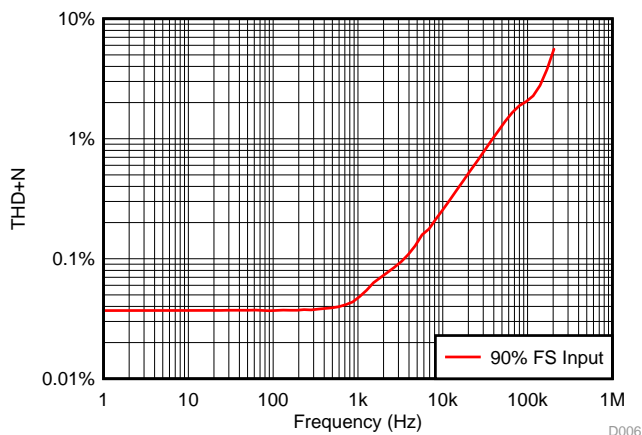

Figure 32. Amplifier Performance Over Frequency

For applications requiring distortion sensitive signals, Figure 32 provides information to show that there is an optimal frequency performance range for the amplifier. The full amplifier bandwidth is always available for fast overcurrent events at the same time that the lower-frequency signals are amplified at a low distortion level. The output signal accuracy is reduced for frequencies closer to the maximum bandwidth. Individual requirements determine the acceptable limits of distortion for high-frequency, current-sensing applications. Testing and evaluation in the end application or circuit are required to determine the acceptance criteria, and to validate the performance levels meet the system specifications.

8.4 Device Functional Modes

8.4.1 Adjusting the Output Midpoint With the Reference Pins

Figure 33 shows a test circuit for reference-divider accuracy. The INA253 output is configurable to allow for unidirectional or bidirectional operation.

CAUTION

Do not connect the REF1 pin or the REF2 pin to any voltage source lower than GND or higher than V_S .

The output voltage is set by applying a voltage or voltages to the reference voltage inputs, REF1 and REF2. The reference inputs are connected to an internal gain network. There is no operational difference between the two reference pins.

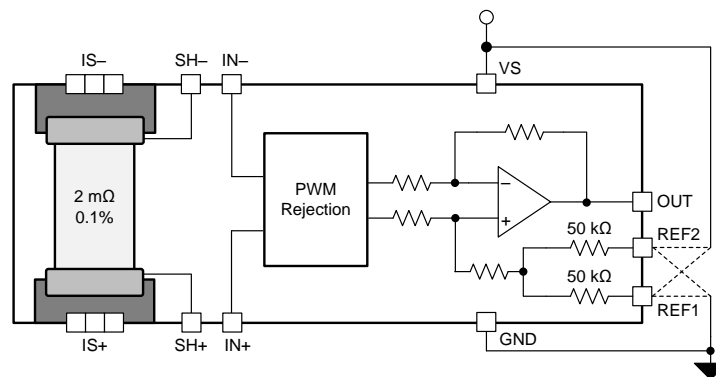

Figure 33. Adjusting the Output Midpoint

8.4.2 Reference Pin Connections for Unidirectional Current Measurements

Unidirectional operation allows current measurements through a resistive shunt in one direction. For unidirectional operation, connect the device reference pins together and then to the negative rail (see the [Ground Referenced Output](#) section). The required differential input polarity depends on the output voltage setting. The amplifier output moves away from the referenced rail proportional to the current passing through the internal shunt resistor.

8.4.3 Ground Referenced Output

When using the INA253 in unidirectional mode with a ground-referenced output, both reference inputs are connected to ground. Figure 34 shows how this configuration takes the output to ground when there is 0-A flowing across the internal shunt.

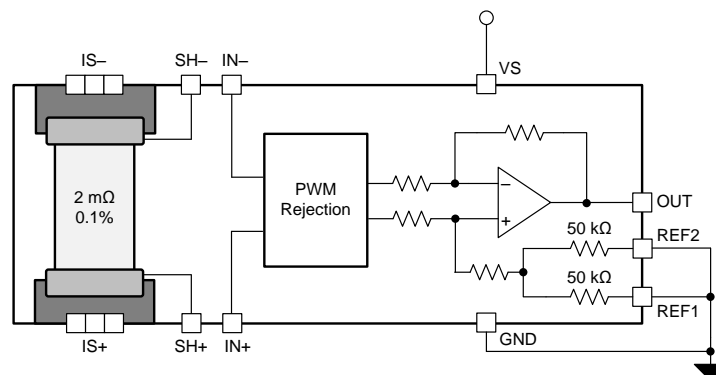

Figure 34. Ground-Referenced Output

Device Functional Modes (continued)

8.4.4 Reference Pin Connections for Bidirectional Current Measurements

Bidirectional operation allows the INA253 to measure currents through a resistive shunt in two directions. For this case, set the output voltage anywhere within the reference input limits. A common configuration is to set the reference inputs at half-scale for equal range in both directions. However, the reference inputs can be set to a voltage other than half-scale when the bidirectional current is nonsymmetrical.

8.4.4.1 Output Set to External Reference Voltage

Connecting both pins together and then to a reference voltage results in an output voltage equal to the reference voltage for the condition of shorted input pins or a 0-V differential input. Figure 35 shows this configuration. The output voltage decreases below the reference voltage when the IN+ pin is negative relative to the IN- pin, and increases when the IN+ pin is positive relative to the IN- pin. This technique is the most accurate way to bias the output to a precise voltage.

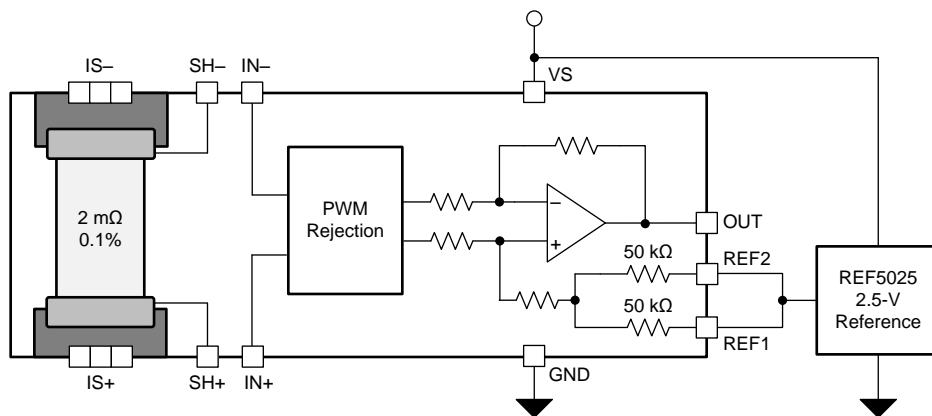

Figure 35. External Reference Output

8.4.5 Output Set to Mid-Supply Voltage

Figure 36 shows that by connecting one reference pin to VS and the other to the GND pin, the output is set at half of the supply when there is no differential input. This method creates a ratiometric offset to the supply voltage, where the output voltage remains at $V_S / 2$ when 0 V is applied between the IN+ and IN- inputs.

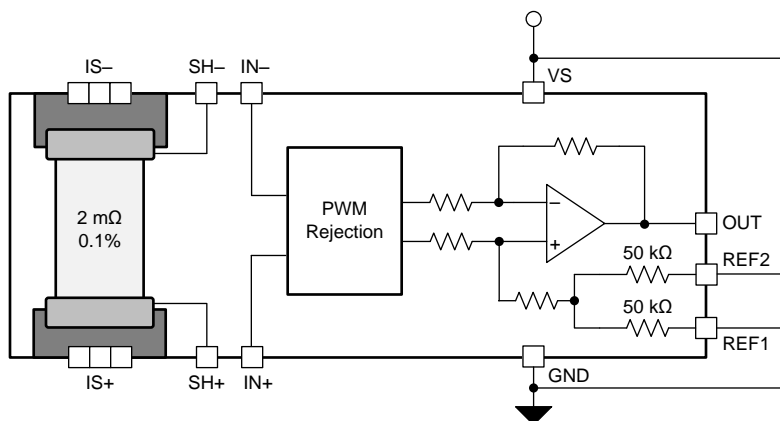

Figure 36. Mid-Supply Voltage Output

Device Functional Modes (continued)

8.4.6 Output Set to Mid-External Reference

In this example, an external reference is divided by two by connecting one REF pin to ground and the other REF pin to the reference, as shown in [Figure 37](#).

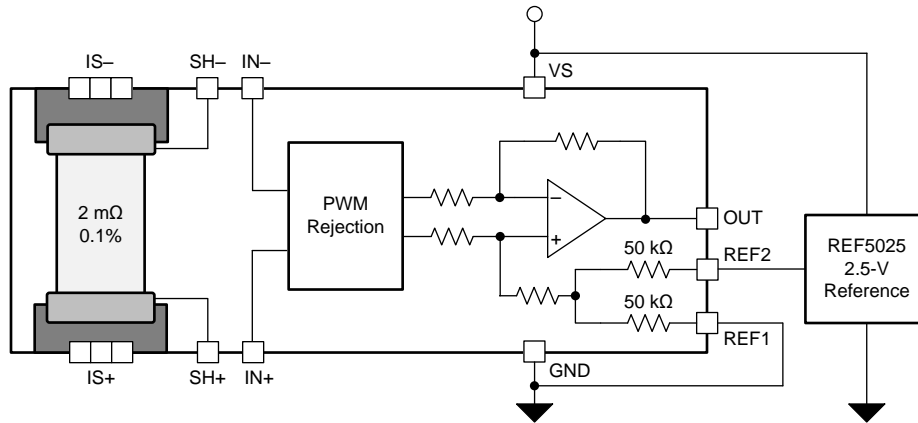

Figure 37. Mid-External Reference Output

8.4.7 Output Set Using Resistor Divide

The INA253 REF1 and REF2 pins allow for the midpoint of the output voltage to be adjusted for system circuitry connections to analog to digital converters (ADCs) or other amplifiers. The REF pins are designed to be connected directly to supply, ground, or a low-impedance reference voltage. The REF pins can be connected together and biased using a resistor divider to achieve a custom output voltage. If the amplifier is used in this configuration, as shown in [Figure 38](#), use the output as a differential signal with respect to the resistor divider voltage. For most accurate results, do not use single-ended measurements at the amplifier output because the internal impedance shifts can adversely affect device performance specifications.

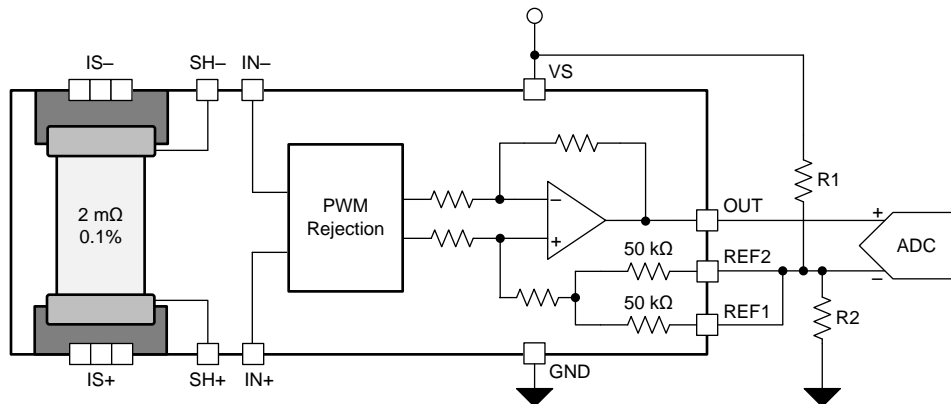

Figure 38. Setting the Reference Using a Resistor Divider

9 Application and Implementation

NOTE

Information in the following applications sections is not part of the TI component specification, and TI does not warrant its accuracy or completeness. TI's customers are responsible for determining suitability of components for their purposes. Customers should validate and test their design implementation to confirm system functionality.

9.1 Application Information

The INA253 measures the voltage developed as current flows across the integrated low inductive current-sensing resistor. The device provides reference pins to configure operation as either unidirectional or bidirectional output swing. When using the INA253 for inline motor current sense or measuring current in an h-bridge, the device is commonly configured for bidirectional operation.

9.1.1 Input Filtering

NOTE

Input filters are not required for accurate measurements using the INA253. For most accurate results, do not use filters at the IN+ and IN– inputs. However, if filter components are used on the input of the amplifier, follow the guidelines in this section to minimize effects on performance.

Based strictly on user design requirements, external filtering of the current signal may be desired. The initial location that can be considered for the filter is at the output of the current amplifier. Although placing the filter at the output satisfies the filtering requirements, this location changes the low output impedance measured by any circuitry connected to the output voltage pin. The other location for filter placement is at the current amplifier input pins. This location also satisfies the filtering requirement, but carefully select the components to minimize the impact on device performance. [Figure 39](#) shows a filter placed at the inputs pins.

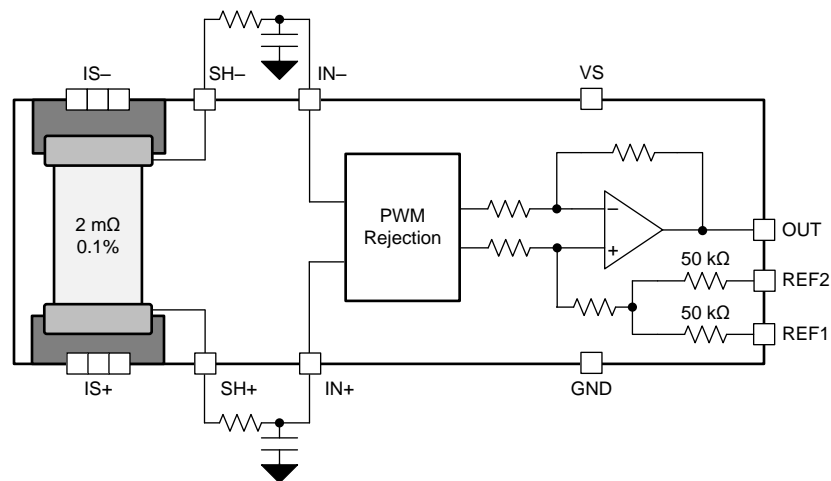
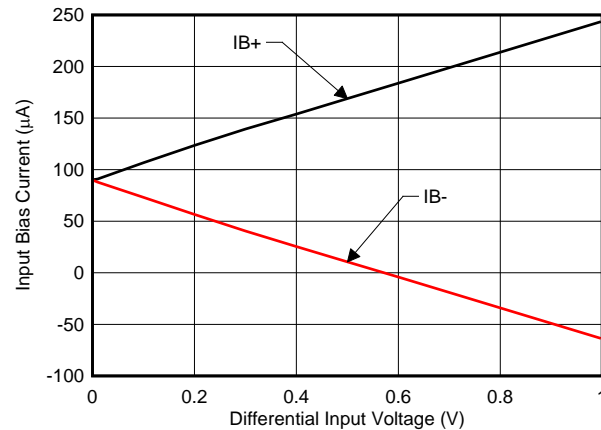

Figure 39. Filter at Input Pins

External series resistance provides a source of additional measurement error. Therefore, keep the value of these series resistors to 10-Ω or less in order to reduce loss of accuracy. The internal bias network shown in [Figure 39](#) creates a mismatch in input bias currents when a differential voltage is applied between the input pins (see [Figure 40](#)). If additional external series filter resistors are added to the circuit, a mismatch is created in the voltage drop across the filter resistors. This voltage is a differential error voltage in the shunt resistor voltage. In addition to the absolute resistor value, mismatch resulting from resistor tolerance can significantly impact the error because this value is calculated based on the actual measured resistance.

Application Information (continued)

Figure 40. Input Bias Current vs Differential Input Voltage

Calculate the measurement error expected from the additional external filter resistors using [Equation 1](#).

$$\text{Gain Error (\%)} = 100 - (100 \times \text{Gain Error Factor})$$

where

- Gain Error Factor is calculated using [Equation 2](#). (1)

$$\text{Gain Error Factor} = \frac{3000}{R_S + 3000}$$

Where:

- R_S is the external filter resistance value (2)

Calculate the gain error factor, shown in [Equation 2](#), in order to determine the gain error introduced by the additional external series resistance. [Equation 1](#) calculates the deviation of the shunt voltage resulting from the attenuation and imbalance created by the added external filter resistance. [Table 1](#) provides the gain error factor and gain error for several resistor values.

Table 1. Gain Error Factor and Gain Error for External Input Resistors

EXTERNAL RESISTANCE (Ω)	GAIN ERROR FACTOR	GAIN ERROR (%)
5	0.998	0.17
10	0.997	0.33
100	0.968	3.23

9.2 Typical Applications

The INA253 offers advantages for multiple applications including the following:

- High common-mode range and excellent CMRR enables direct inline sensing
- Precision low-inductive, low-drift shunt eliminates the need for overtemperature system calibration
- Ultra-low offset and drift eliminates the necessity of calibration
- Wide supply range enables a direct interface with most microprocessors

9.2.1 High-Side, High-Drive, Solenoid Current-Sense Application

Challenges exist in solenoid drive current sensing that are similar to those in motor inline current sensing. In certain topologies, the current-sensing amplifier is exposed to the full-scale PWM voltage between ground and supply. The INA253 is an excellent choice for this type of application. The 2-m Ω integrated shunt with a total system accuracy of 0.2% with a total system drift of 25 ppm/ $^{\circ}$ C provides system accuracy across temperature eliminating the need for tri temperature system calibration.

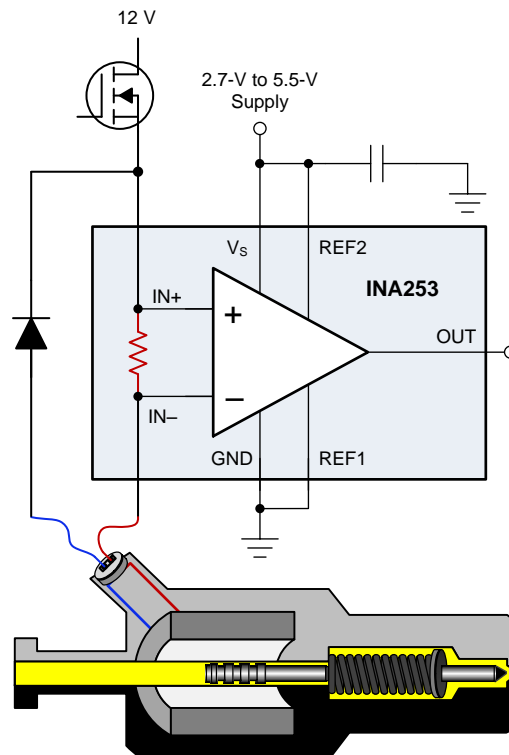

Figure 41. Solenoid Drive Application Circuit

9.2.1.1 Design Requirements

For this application, the INA253 measures current in the driver circuit of a 12-V, 500-mA hydraulic valve.

Table 2. Design Parameters

DESIGN PARAMETER	EXAMPLE VALUE
Common-mode voltage	12 V
Maximum sense current	500 mA
Power-supply voltage	3.3 V

9.2.1.2 Detailed Design Procedure

To demonstrate the performance of the device, the INA253, with a gain of 400mV/A, is selected for this design and powered from a 5-V supply.

Using the information in the [Output Set to Mid-Supply Voltage](#) section, the reference point is set to midscale by splitting the supply with REF1 connected to ground and REF2 connected to supply. Alternatively, the reference pins can be tied together and driven with an external precision reference.

9.2.1.3 Application Curve

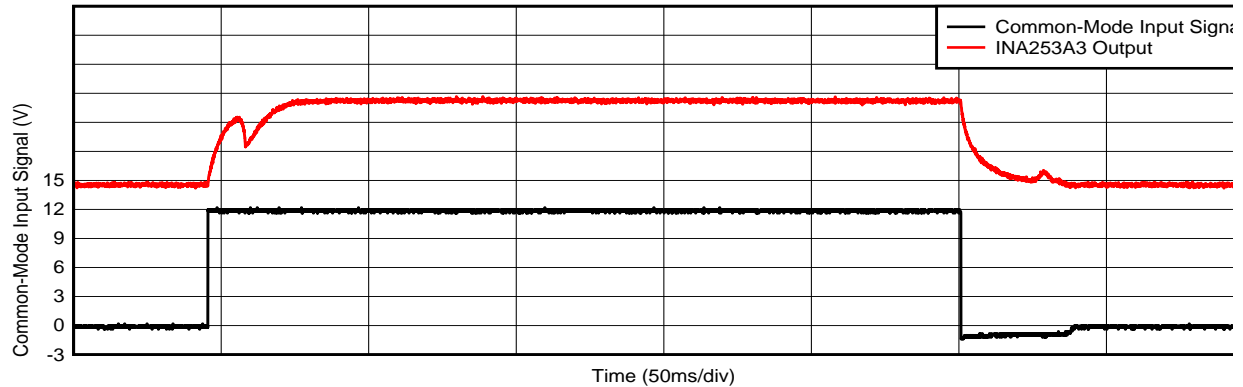

Figure 42. Solenoid Drive Current Sense Input and Output Signals

9.2.2 Speaker Enhancements and Diagnostics Using Current Sense Amplifier

CLASS-D audio amplifiers in conjunction with the INA253 provide accurate speaker load current. Speaker load current is used to determine speaker diagnostics, and can further be expanded to measure key speaker parameters, such as speaker coil resistance and speaker real-time ambient temperature.

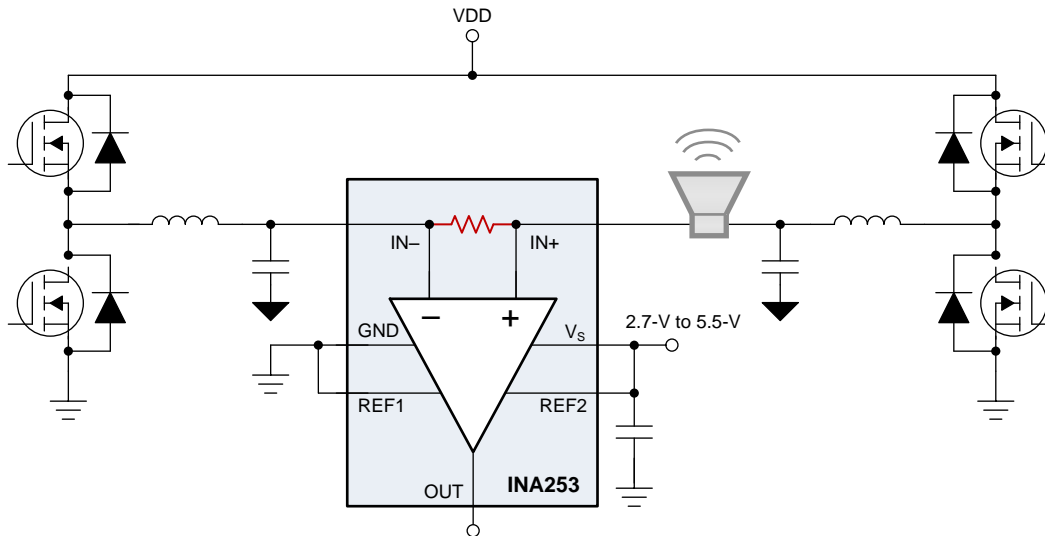

Figure 43. Current Sensing in a CLASS-D Subsystem

9.2.2.1 Design Requirements

Table 3. Design Parameters

DESIGN PARAMETER	EXAMPLE VALUE
Common-mode voltage	24 V
Power-supply voltage	5 V
Maximum rms current	5 A
Frequency sweep	20 Hz to 20 KHz

9.2.2.2 Detailed Design Procedure

For this application, the INA253 measures current flowing through the speaker from the CLASS-D amplifier. The integrated shunt of 2 mΩ with an inductance of only 3 nH is an excellent choice for current sensing in speaker applications where low inductance is required. The low-inductive shunt enables accurate current sensing across frequencies over the audio range of 20 hz to 20 kHz.

The INA253 is setup in a bidirectional with the reference set to mid-supply as shown in Figure 37. The power supply to INA253 is setup at 5 V. The output of INA253 is set at 2.5 V. The INA253 with a gain of 100 mV/A, the INA253 output for a peak to peak of 10-A current the output of the INA253 will swing from 3.5 V to 1.5 V. The output can be directly connected to ADC input that has a full scale range of 5 V. The INA253 has a low THD+N of 0.1% at 1 kHz that enables distortion measurement of speaker. The INA253 can measure the impedance of the speaker and accurately measure the resonance frequency and peak impedance at resonance frequency. The INA253 can accurately track changes in impedance real time.

9.2.2.3 Application Curve

A typical example output response of speaker of 4-Ω impedance measurement from 20 Hz to 20 kHz is as shown in [Figure 44](#).

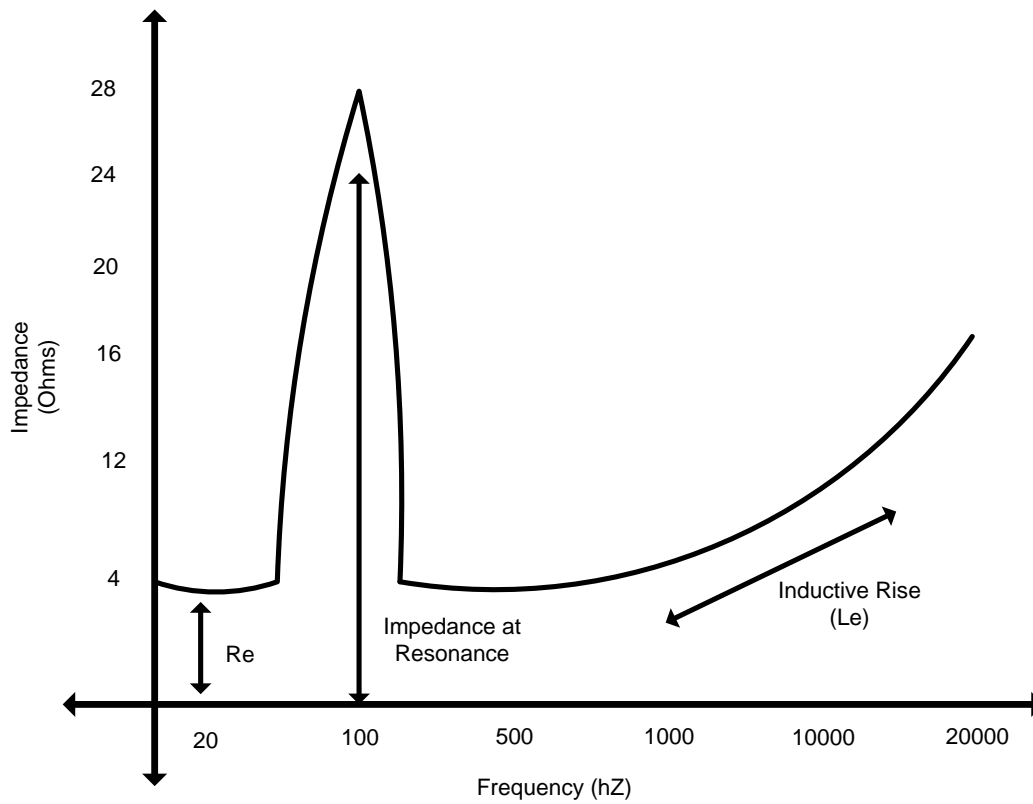

Figure 44. Speaker Impedance Measurement

9.2.3 Current Sensing for Remote I/Os in PLC

In industrial remote I/Os, there is often one power supply for several ports, as shown in Figure 45. For example, an IO-Link master has one power supply of 24 V 5 A, but eight IO-Link ports, where each port can deliver up to 1 A. The IO-Link master must measure the total current to make sure in order to not overload the power supply. To prevent from overloading the system, each port is only turned on if sufficient headroom in the total system current is available. Figure 45 shows the block diagram of such a system. This example is implemented on TI reference design TIDA-010016. The INA253 is an excellent choice for this design because this device is simple to use, and delivers high accuracy over a wide temperature range. The integrated 2-mΩ shunt has a low voltage drop and therefore low power dissipation.

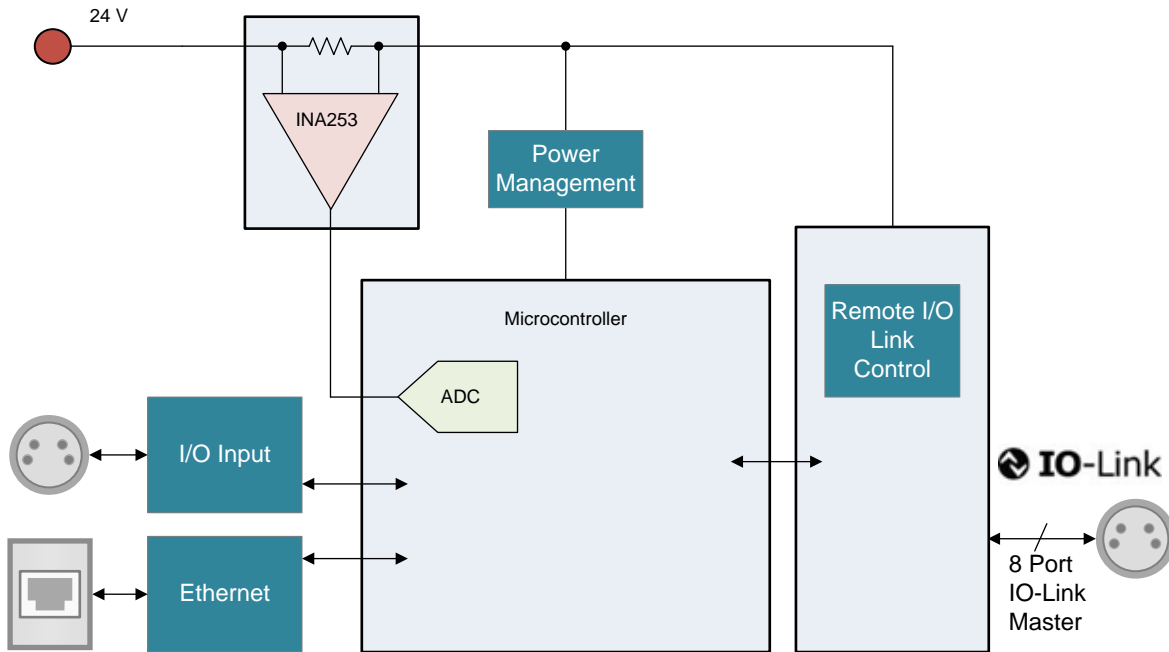

Figure 45. Current Sensing in Remote I/O

9.2.3.1 Design Requirements

Table 4. Design Parameters

DESIGN PARAMETER	EXAMPLE VALUE
Common-mode voltage	24 V
Maximum current	9 A
ADC input voltage	1.8 V
Supply voltage	3.3 V

In this design, the current flow is unidirectional; therefore, the REF inputs must be tied to GND. Because of the given ADC input range and current, the 200-mV/A version is chosen.

9.2.3.2 Application Curve

A typical response of INA253 in a remote I/O application is shown in Figure 46. The common-mode voltage steps from 0 V to 24 V, and the current output across the 24 V power supply is measured using the INA253.

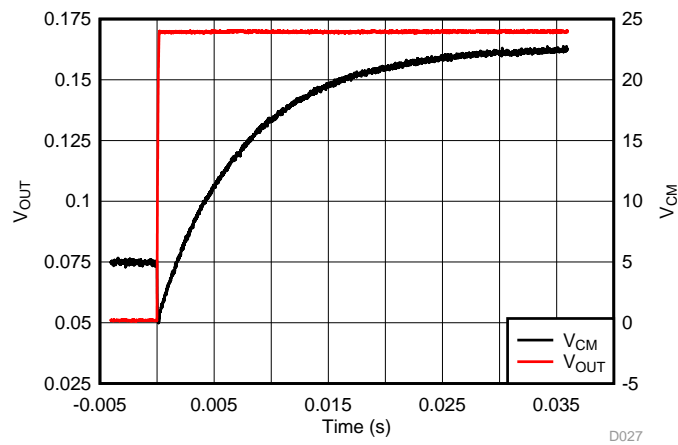

Figure 46. INA253 Current Sense Output Response in Remote I/O

10 Power Supply Recommendations

The INA253 makes accurate measurements beyond the connected power-supply voltage (V_S) because the inputs (IN+ and IN-) operate anywhere between -4 V and $+80\text{ V}$, independent of V_S . For example, the V_S power supply equals 5 V and the common-mode voltage of the measured shunt can be as high as 80 V . Although the common-mode voltage of the input can be beyond the supply voltage, the output voltage range of the INA253 is constrained to the supply voltage.

Place the power-supply bypass capacitor as close as possible to the supply and ground pins. The recommended value of this bypass capacitor is $0.1\text{ }\mu\text{F}$. Additional decoupling capacitance can be added to compensate for noisy or high-impedance power supplies. If the INA253 output is set to mid-supply, then take extreme care to minimize noise on the power supply.

11 Layout

11.1 Layout Guidelines

- This device is specified for current handling of up to 10 A over the entire -40°C to $+125^\circ\text{C}$ temperature range using a 1-oz copper pour for the input power plane, as well as no external airflow passing over the device.
- The primary current-handling limitation for this device is how much heat is dissipated inside the package. Efforts to improve heat transfer out of the package and into the surrounding environment improve the ability of the device to handle currents of up to 15 A over the entire -40°C to $+125^\circ\text{C}$ temperature range.
- Heat transfer improvements primarily involve larger copper power traces and planes with increased copper thickness (2 oz), as well as providing airflow to pass over the device. The INA253 evaluation module (EVM) features a 2-oz copper pour for the planes, and is capable of supporting 15 A at temperatures up to 125°C .
- Place the power-supply bypass capacitor as close as possible to the supply and ground pins. The recommended value of this bypass capacitor is $0.1\text{ }\mu\text{F}$. Additional decoupling capacitance can be added to compensate for noisy or high-impedance power supplies.

11.2 Layout Example

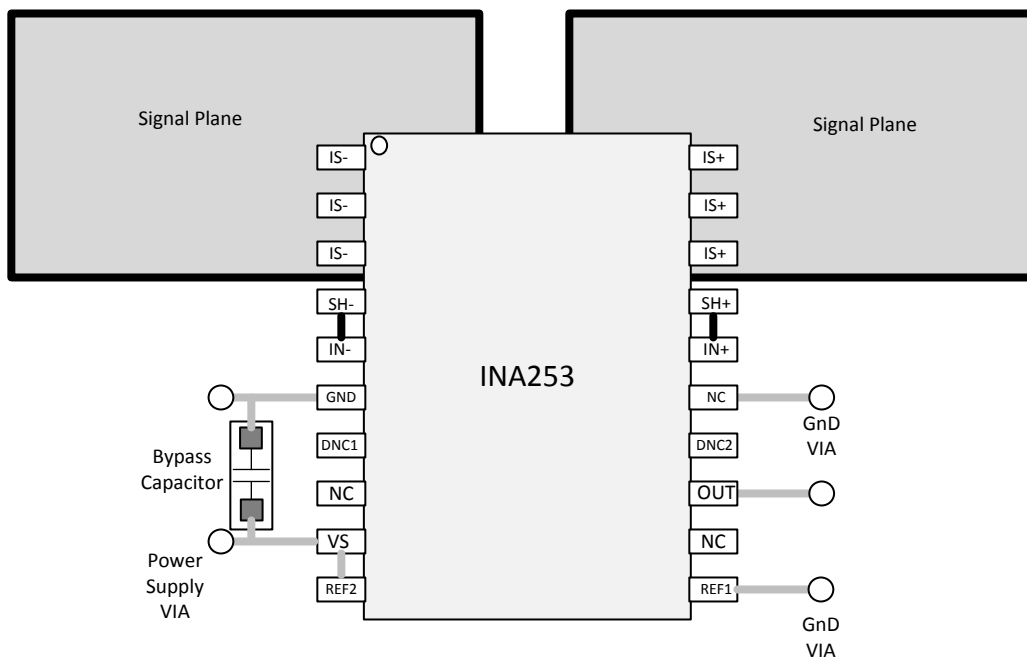

Figure 47. INA253 Layout Example

12 Device and Documentation Support

12.1 Device Support

12.1.1 Development Support

[INA253 Evaluation Module \(EVM\)](#)

12.2 Related Documentation

For related documentation see the following: [INA253EVM User's Guide](#)

12.3 Receiving Notification of Documentation Updates

To receive notification of documentation updates, navigate to the device product folder on ti.com. In the upper right corner, click on *Alert me* to register and receive a weekly digest of any product information that has changed. For change details, review the revision history included in any revised document.

12.4 Community Resources

The following links connect to TI community resources. Linked contents are provided "AS IS" by the respective contributors. They do not constitute TI specifications and do not necessarily reflect TI's views; see TI's [Terms of Use](#).

TI E2E™ Online Community *TI's Engineer-to-Engineer (E2E) Community*. Created to foster collaboration among engineers. At e2e.ti.com, you can ask questions, share knowledge, explore ideas and help solve problems with fellow engineers.

Design Support *TI's Design Support* Quickly find helpful E2E forums along with design support tools and contact information for technical support.

12.5 Trademarks

E2E is a trademark of Texas Instruments.
All other trademarks are the property of their respective owners.

12.6 Electrostatic Discharge Caution



This integrated circuit can be damaged by ESD. Texas Instruments recommends that all integrated circuits be handled with appropriate precautions. Failure to observe proper handling and installation procedures can cause damage.

ESD damage can range from subtle performance degradation to complete device failure. Precision integrated circuits may be more susceptible to damage because very small parametric changes could cause the device not to meet its published specifications.

12.7 Glossary

[SLYZ022](#) — *TI Glossary*.

This glossary lists and explains terms, acronyms, and definitions.

13 Mechanical, Packaging, and Orderable Information

The following pages include mechanical, packaging, and orderable information. This information is the most current data available for the designated devices. This data is subject to change without notice and revision of this document. For browser-based versions of this data sheet, refer to the left-hand navigation.

PACKAGING INFORMATION

Orderable Device	Status (1)	Package Type	Package Drawing	Pins	Package Qty	Eco Plan (2)	Lead finish/ Ball material (6)	MSL Peak Temp (3)	Op Temp (°C)	Device Marking (4/5)	Samples
INA253A1IPW	NRND	TSSOP	PW	20	70	RoHS & Green	NIPDAU	Level-2-260C-1 YEAR	-40 to 125	I253A1	
INA253A1IPWR	ACTIVE	TSSOP	PW	20	2000	RoHS & Green	NIPDAU	Level-2-260C-1 YEAR	-40 to 125	I253A1	Samples
INA253A2IPW	NRND	TSSOP	PW	20	70	RoHS & Green	NIPDAU	Level-2-260C-1 YEAR	-40 to 125	I253A2	
INA253A2IPWR	ACTIVE	TSSOP	PW	20	2000	RoHS & Green	NIPDAU	Level-2-260C-1 YEAR	-40 to 125	I253A2	Samples
INA253A3IPW	NRND	TSSOP	PW	20	70	RoHS & Green	NIPDAU	Level-2-260C-1 YEAR	-40 to 125	I253A3	
INA253A3IPWR	ACTIVE	TSSOP	PW	20	2000	RoHS & Green	NIPDAU	Level-2-260C-1 YEAR	-40 to 125	I253A3	Samples

(1) The marketing status values are defined as follows:

ACTIVE: Product device recommended for new designs.

LIFEBUY: TI has announced that the device will be discontinued, and a lifetime-buy period is in effect.

NRND: Not recommended for new designs. Device is in production to support existing customers, but TI does not recommend using this part in a new design.

PREVIEW: Device has been announced but is not in production. Samples may or may not be available.

OBSELETE: TI has discontinued the production of the device.

(2) **RoHS:** TI defines "RoHS" to mean semiconductor products that are compliant with the current EU RoHS requirements for all 10 RoHS substances, including the requirement that RoHS substance do not exceed 0.1% by weight in homogeneous materials. Where designed to be soldered at high temperatures, "RoHS" products are suitable for use in specified lead-free processes. TI may reference these types of products as "Pb-Free".

RoHS Exempt: TI defines "RoHS Exempt" to mean products that contain lead but are compliant with EU RoHS pursuant to a specific EU RoHS exemption.

Green: TI defines "Green" to mean the content of Chlorine (Cl) and Bromine (Br) based flame retardants meet JS709B low halogen requirements of <=1000ppm threshold. Antimony trioxide based flame retardants must also meet the <=1000ppm threshold requirement.

(3) MSL, Peak Temp. - The Moisture Sensitivity Level rating according to the JEDEC industry standard classifications, and peak solder temperature.

(4) There may be additional marking, which relates to the logo, the lot trace code information, or the environmental category on the device.

(5) Multiple Device Markings will be inside parentheses. Only one Device Marking contained in parentheses and separated by a "~" will appear on a device. If a line is indented then it is a continuation of the previous line and the two combined represent the entire Device Marking for that device.

(6) Lead finish/Ball material - Orderable Devices may have multiple material finish options. Finish options are separated by a vertical ruled line. Lead finish/Ball material values may wrap to two lines if the finish value exceeds the maximum column width.

Important Information and Disclaimer: The information provided on this page represents TI's knowledge and belief as of the date that it is provided. TI bases its knowledge and belief on information provided by third parties, and makes no representation or warranty as to the accuracy of such information. Efforts are underway to better integrate information from third parties. TI has taken and continues to take reasonable steps to provide representative and accurate information but may not have conducted destructive testing or chemical analysis on incoming materials and chemicals. TI and TI suppliers consider certain information to be proprietary, and thus CAS numbers and other limited information may not be available for release.

In no event shall TI's liability arising out of such information exceed the total purchase price of the TI part(s) at issue in this document sold by TI to Customer on an annual basis.

OTHER QUALIFIED VERSIONS OF INA253 :

- Automotive : [INA253-Q1](#)

NOTE: Qualified Version Definitions:

- Automotive - Q100 devices qualified for high-reliability automotive applications targeting zero defects

TAPE AND REEL INFORMATION

QUADRANT ASSIGNMENTS FOR PIN 1 ORIENTATION IN TAPE

*All dimensions are nominal

Device	Package Type	Package Drawing	Pins	SPQ	Reel Diameter (mm)	Reel Width W1 (mm)	A0 (mm)	B0 (mm)	K0 (mm)	P1 (mm)	W (mm)	Pin1 Quadrant
INA253A1IPWR	TSSOP	PW	20	2000	330.0	16.4	6.95	7.0	1.4	8.0	16.0	Q1
INA253A2IPWR	TSSOP	PW	20	2000	330.0	16.4	6.95	7.0	1.4	8.0	16.0	Q1
INA253A3IPWR	TSSOP	PW	20	2000	330.0	16.4	6.95	7.0	1.4	8.0	16.0	Q1

TAPE AND REEL BOX DIMENSIONS

*All dimensions are nominal

Device	Package Type	Package Drawing	Pins	SPQ	Length (mm)	Width (mm)	Height (mm)
INA253A1IPWR	TSSOP	PW	20	2000	356.0	356.0	35.0
INA253A2IPWR	TSSOP	PW	20	2000	356.0	356.0	35.0
INA253A3IPWR	TSSOP	PW	20	2000	356.0	356.0	35.0

TUBE

*All dimensions are nominal

Device	Package Name	Package Type	Pins	SPQ	L (mm)	W (mm)	T (μm)	B (mm)
INA253A1IPW	PW	TSSOP	20	70	530	10.2	3600	3.5
INA253A2IPW	PW	TSSOP	20	70	530	10.2	3600	3.5
INA253A3IPW	PW	TSSOP	20	70	530	10.2	3600	3.5

PW0020A



PACKAGE OUTLINE

TSSOP - 1.2 mm max height

SMALL OUTLINE PACKAGE



4220206/A 02/2017

NOTES:

- All linear dimensions are in millimeters. Any dimensions in parenthesis are for reference only. Dimensioning and tolerancing per ASME Y14.5M.
- This drawing is subject to change without notice.
- This dimension does not include mold flash, protrusions, or gate burrs. Mold flash, protrusions, or gate burrs shall not exceed 0.15 mm per side.
- This dimension does not include interlead flash. Interlead flash shall not exceed 0.25 mm per side.
- Reference JEDEC registration MO-153.

EXAMPLE BOARD LAYOUT

PW0020A

TSSOP - 1.2 mm max height

SMALL OUTLINE PACKAGE



LAND PATTERN EXAMPLE
EXPOSED METAL SHOWN
SCALE: 10X



SOLDER MASK DETAILS

4220206/A 02/2017

NOTES: (continued)

- 6. Publication IPC-7351 may have alternate designs.
- 7. Solder mask tolerances between and around signal pads can vary based on board fabrication site.

EXAMPLE STENCIL DESIGN

PW0020A

TSSOP - 1.2 mm max height

SMALL OUTLINE PACKAGE



SOLDER PASTE EXAMPLE
BASED ON 0.125 mm THICK STENCIL
SCALE: 10X

4220206/A 02/2017

NOTES: (continued)

8. Laser cutting apertures with trapezoidal walls and rounded corners may offer better paste release. IPC-7525 may have alternate design recommendations.
9. Board assembly site may have different recommendations for stencil design.

IMPORTANT NOTICE AND DISCLAIMER

TI PROVIDES TECHNICAL AND RELIABILITY DATA (INCLUDING DATA SHEETS), DESIGN RESOURCES (INCLUDING REFERENCE DESIGNS), APPLICATION OR OTHER DESIGN ADVICE, WEB TOOLS, SAFETY INFORMATION, AND OTHER RESOURCES "AS IS" AND WITH ALL FAULTS, AND DISCLAIMS ALL WARRANTIES, EXPRESS AND IMPLIED, INCLUDING WITHOUT LIMITATION ANY IMPLIED WARRANTIES OF MERCHANTABILITY, FITNESS FOR A PARTICULAR PURPOSE OR NON-INFRINGEMENT OF THIRD PARTY INTELLECTUAL PROPERTY RIGHTS.

These resources are intended for skilled developers designing with TI products. You are solely responsible for (1) selecting the appropriate TI products for your application, (2) designing, validating and testing your application, and (3) ensuring your application meets applicable standards, and any other safety, security, regulatory or other requirements.

These resources are subject to change without notice. TI grants you permission to use these resources only for development of an application that uses the TI products described in the resource. Other reproduction and display of these resources is prohibited. No license is granted to any other TI intellectual property right or to any third party intellectual property right. TI disclaims responsibility for, and you will fully indemnify TI and its representatives against, any claims, damages, costs, losses, and liabilities arising out of your use of these resources.

TI's products are provided subject to [TI's Terms of Sale](#) or other applicable terms available either on [ti.com](https://www.ti.com) or provided in conjunction with such TI products. TI's provision of these resources does not expand or otherwise alter TI's applicable warranties or warranty disclaimers for TI products.

TI objects to and rejects any additional or different terms you may have proposed.

Mailing Address: Texas Instruments, Post Office Box 655303, Dallas, Texas 75265
Copyright © 2024, Texas Instruments Incorporated