

INA790x –4V to 110V, Bidirectional, Ultra-Precise, Current Sense Amplifier With Enhanced PWM Rejection and 75A EZShunt™ Technology

1 Features

- Precision solution with integrated shunt resistor
 - $\pm 75\text{A}$ continuous current at 25°C
 - $\pm 50\text{A}$ continuous current at $+125^\circ\text{C}$
 - Shunt resistor: $400\mu\Omega$
 - Shunt inductance: 2nH
- Wide common-mode voltage range: -4V to $+110\text{V}$
- Enhanced PWM rejection optimized for systems subject to switching common-mode voltages
 - Supports switching frequencies up to 125kHz
- Excellent CMRR
 - 160dB DC CMRR
 - 114dB AC CMRR at 50kHz
- High measurement accuracy
 - System Gain error (maximum)
 - Version A: $\pm 0.35\%$, $\pm 35\text{ppm}/^\circ\text{C}$ drift
 - Version B: $\pm 1\%$, $\pm 100\text{ppm}/^\circ\text{C}$ drift
 - Offset current (maximum)
 - Version A: $\pm 30\text{mA}$, $\pm 625\mu\text{A}/^\circ\text{C}$ drift
 - Version B: $\pm 250\text{mA}$, $\pm 1.25\text{mA}/^\circ\text{C}$ drift
- Adjustable gain with external resistor divider network:
 - $20\text{mV}/\text{A}$ to $400\text{mV}/\text{A}$
- Open-drain temperature alert at T_J of 160°C
- Package options: VQFN-15

2 Applications

- [Motor drives](#)
- [Solenoids and actuators](#)
- [Injection molding machine](#)
- [Cordless power tools](#)
- [Medical cordless tools](#)
- [Drone propeller speed control](#)

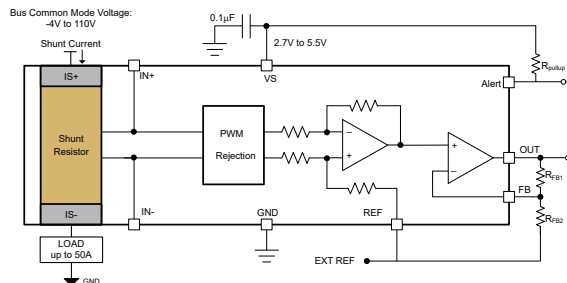

Typical Application

3 Description

The INA790x is a voltage output, current sense amplifier with an integrated shunt resistor of $400\mu\Omega$. The INA790x is designed to monitor bidirectional current over a common-mode range of -4V to 110V , independent of the supply voltage. Adjustable gain option assists in optimizing the system dynamic range. The integration of the Kelvin connected shunt resistor with a zero-drift chopped amplifier provides calibration equivalent measurement accuracy, ultra-low temperature drift performance of $\pm 35\text{ppm}/^\circ\text{C}$, and an optimized layout for the sensing resistor.

The INA790x is designed with enhanced PWM rejection circuitry to suppress disturbance from large (dv/dt) common-mode transients and enable real-time continuous current measurements in switching systems. The continuous measurements are critical for inline current measurements in a motor-drive application, and for solenoid valve control application.

This device operates from a single 2.7V to 5.5V power supply, drawing a maximum of 4.25mA of supply current. All versions are specified over the extended operating temperature range (-40°C to $+125^\circ\text{C}$), and are available in a 15-pin VQFN package.

Package Information

PART NUMBER	PACKAGE ⁽¹⁾	PACKAGE SIZE ⁽²⁾
INA790A, INA790B	DEK (VQFN, 15)	6mm × 6mm

- (1) For all available packages, see the orderable addendum at the end of the data sheet.
- (2) The package size (length × width) is a nominal value and includes pins, where applicable.

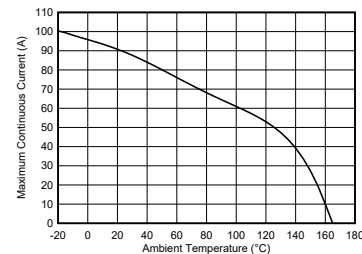

Maximum Continuous Current vs Ambient Temperature



Table of Contents

1 Features	1	6.4 Device Functional Modes.....	15
2 Applications	1	7 Application and Implementation	20
3 Description	1	7.1 Application Information.....	20
4 Pin Configuration and Functions	3	7.2 Typical Applications.....	25
5 Specifications	4	7.3 Power Supply Recommendations.....	29
5.1 Absolute Maximum Ratings.....	4	7.4 Layout.....	29
5.2 ESD Ratings.....	4	8 Device and Documentation Support	30
5.3 Recommended Operating Conditions.....	4	8.1 Documentation Support.....	30
5.4 Thermal Information.....	4	8.2 Receiving Notification of Documentation Updates....	31
5.5 Electrical Characteristics.....	5	8.3 Support Resources.....	31
5.6 Typical Characteristics.....	7	8.4 Trademarks.....	31
6 Detailed Description	12	8.5 Electrostatic Discharge Caution.....	31
6.1 Overview.....	12	8.6 Glossary.....	31
6.2 Functional Block Diagram.....	12	9 Revision History	31
6.3 Feature Description.....	12		

4 Pin Configuration and Functions

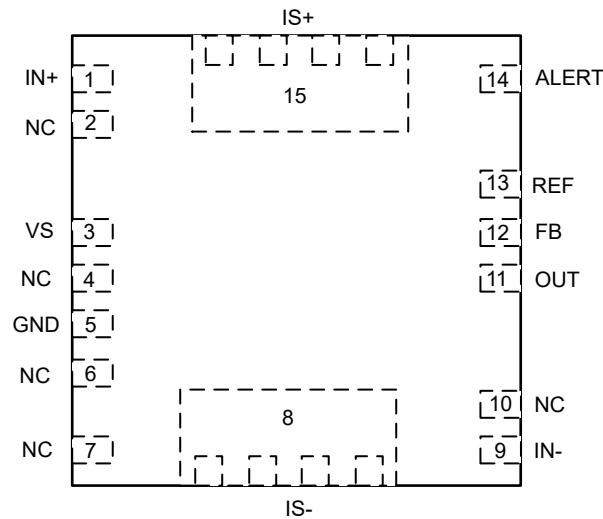

Figure 4-1. INA790x DEK Package 15-Pin VQFN Top View

Table 4-1. Pin Functions

PIN		Type	DESCRIPTION
NAME	NO.		
ALERT	14	Digital Out	Open-drain temperature alert
FB	12	Analog Input	Gain adjustment feedback; connect to resistor divider to adjust device gain
GND	5	Analog	Ground
IN-	9	Analog Input	Kelvin connection to internal shunt on load side and negative amplifier input
IN+	1	Analog Input	Kelvin connection to internal shunt on supply side and positive amplifier input
IS-	8	Analog Input	Connect to load
IS+	15	Analog Input	Connect to supply
NC	2	–	Connect to IN+ (Pin 1)
NC	4, 6, 7	–	Connect to ground or leave unconnected
NC	10	–	Connect to IN- (Pin 9)
OUT	11	Analog Output	Output voltage
REF	13	Analog Input	Reference voltage, 0V to VS
VS	3	Analog	Power supply, 2.7V to 5.5V

5 Specifications

5.1 Absolute Maximum Ratings

over operating free-air temperature range (unless otherwise noted)⁽¹⁾

		MIN	MAX	UNIT
Supply voltage (V_S)			6	V
Analog Inputs, V_{IN+} , V_{IN-} ⁽²⁾	Differential (V_{IN+}) - (V_{IN-})	-12	12	V
	Common-mode	GND – 20	120	V
Analog input (REF)	Analog input (REF)	GND – 0.3	$V_S + 0.3$	V
Analog input (FB)	Analog input (FB)	GND – 0.3	$V_S + 0.3$	V
Analog output (OUT)	Analog output (OUT)	GND – 0.3	$V_S + 0.3$	V
Digital output (ALERT)	Temperature Alert Output	GND – 0.3	$V_S + 0.3$	V
T_A	Operating Temperature	-55	150	°C
T_J	Junction temperature		165	°C
T_{stg}	Storage temperature	-65	165	°C

- (1) Operation outside the Absolute Maximum Ratings may cause permanent device damage. Absolute Maximum Ratings do not imply functional operation of the device at these or any other conditions beyond those listed under Recommended Operating Conditions. If used outside the Recommended Operating Conditions but within the Absolute Maximum Ratings, the device may not be fully functional, and this may affect device reliability, functionality, performance, and shorten the device lifetime.
- (2) V_{IN+} and V_{IN-} are the voltages at the IN+ and IN– pins, respectively.

5.2 ESD Ratings

			VALUE	UNIT
$V_{(ESD)}$	Electrostatic discharge	Human body model (HBM), per ANSI/ESDA/JEDEC JS-001, all pins ⁽¹⁾	±2000	V
		Charged device model (CDM), per ANSI/ESDA/JEDEC JS-002, all pins ⁽²⁾	±1000	

- (1) JEDEC document JEP155 states that 500V HBM allows safe manufacturing with a standard ESD control process.
- (2) JEDEC document JEP157 states that 250V CDM allows safe manufacturing with a standard ESD control process.

5.3 Recommended Operating Conditions

over operating free-air temperature range (unless otherwise noted)

		MIN	NOM	MAX	UNIT
V_{CM}	Common-mode input range	-4		110	V
V_S	Operating supply range	2.7		5.5	V
I_{SENSE}	Continuous Current	-50		50	A
V_{REF}	Reference voltage range	0		V_S	V
V_{FB}	Feed-back voltage range	0		V_S	V
T_A	Ambient temperature	-40		125	°C

5.4 Thermal Information

THERMAL METRIC ⁽¹⁾		INA790x	UNIT
		DEK (VQFN)	
		15 PINS	
$R_{\theta JA}$	Junction-to-ambient thermal resistance	28.7	°C/W
$R_{\theta JC(top)}$	Junction-to-case (top) thermal resistance	8.3	°C/W
$R_{\theta JB}$	Junction-to-board thermal resistance ⁽²⁾	30.8	°C/W
Ψ_{JT}	Junction-to-top characterization parameter ⁽²⁾	1.1	°C/W
Ψ_{JB}	Junction-to-board characterization parameter ⁽²⁾	8.4	°C/W

- (1) For more information about traditional and new thermal metrics, see the [Semiconductor and IC Package Thermal Metrics](#) application note.

(2) Thermal metrics are relative to the internal die and are conservative relative to the heating that occur from the package leadframe shunt. For more details on heating, see the Safe Operating Area section.

5.5 Electrical Characteristics

at $T_A = 25^\circ\text{C}$, $V_S = 5\text{V}$, $I_{\text{SENSE}} = I_{\text{S}+} = 0\text{A}$, $V_{\text{CM}} = V_{\text{IN}-} = 48\text{V}$, $V_{\text{FB}} = V_{\text{OUT}}$ (Adjustable Gain = 1), and $V_{\text{REF}} = V_S / 2$ (unless otherwise noted)

PARAMETER	TEST CONDITIONS	MIN	TYP	MAX	UNIT		
INPUT							
V_{CM}	Common-mode input range	$V_{\text{IN}+} = -4\text{V to } 110\text{V}$, $I_{\text{SENSE}} = 0\text{A}$, $T_A = -40^\circ\text{C to } +125^\circ\text{C}$		-4	110	V	
CMRR	Common-mode rejection ratio	$V_{\text{IN}+} = -4\text{V to } 110\text{V}$, $I_{\text{SENSE}} = 0\text{A}$, $T_A = -40^\circ\text{C to } +125^\circ\text{C}$, INA790A		± 25	± 79	$\mu\text{A/V}$	
		$V_{\text{IN}+} = -4\text{V to } 110\text{V}$, $I_{\text{SENSE}} = 0\text{A}$, $T_A = -40^\circ\text{C to } +125^\circ\text{C}$, INA790B		± 790	± 1250		
CMRR	Common-mode rejection ratio	$f = 50\text{kHz}$		± 56		mA/V	
I_{os}	Input referred offset current error	$I_{\text{SENSE}} = 0\text{A}$, INA790A		± 5	± 30	mA	
		$I_{\text{SENSE}} = 0\text{A}$, INA790B		± 62.5	± 250		
dI_{os}/dT	Input referred offset current error drift	$I_{\text{SENSE}} = 0\text{A}$, $T_A = -40^\circ\text{C to } +125^\circ\text{C}$, INA790A		± 0.125	± 0.625	$\text{mA}/^\circ\text{C}$	
		$I_{\text{SENSE}} = 0\text{A}$, $T_A = -40^\circ\text{C to } +125^\circ\text{C}$, INA790B		± 0.250	± 1.25		
PSRR	Power supply rejection ratio	$V_S = 2.7\text{V to } 5.5\text{V}$, $V_{\text{REF}} = 1\text{V}$, $I_{\text{SENSE}} = 0\text{A}$, INA790A		± 0.25	± 2.5	mA/V	
		$V_S = 2.7\text{V to } 5.5\text{V}$, $V_{\text{REF}} = 1\text{V}$, $I_{\text{SENSE}} = 0\text{A}$, INA790B		± 2.5	± 25		
I_{B}	Total input bias current	$I_{\text{B}+} + I_{\text{B}-}$, $I_{\text{SENSE}} = 0\text{A}$		45	66	90	μA
I_{FB}	Feed-back current	$I_{\text{SENSE}} = 0\text{A}$		± 2		nA	
		$I_{\text{SENSE}} = 0\text{A}$, $T_A = -40^\circ\text{C to } +125^\circ\text{C}$			± 6		
INTEGRATED SHUNT RESISTOR							
R_{SHUNT}	Internal Kelvin shunt resistance	$\text{IN}+ \text{ to } \text{IN}-$, $T_A = 25^\circ\text{C}$			400	$\mu\Omega$	
	Pin to pin package resistance	$\text{IS}+ \text{ to } \text{IS}-$, $T_A = 25^\circ\text{C}$		425	560	650	$\mu\Omega$
	Pin to pin package inductance	$\text{IS}+ \text{ to } \text{IS}-$, $T_A = 25^\circ\text{C}$			2		nH
I_{SENSE}	Maximum Continuous Current	$T_A = -40^\circ\text{C to } +125^\circ\text{C}$				± 50	A
	Short time overload change	$I_{\text{SENSE}} = 120\text{A}$ for 5 seconds			± 0.05		%
	Change due to temperature cycle	$-65^\circ\text{C to } 150^\circ\text{C}$, 500 cycles			± 0.1		%
	Shunt resistance change to solder heat	260°C solder, 10 seconds			± 0.1		%
	High temperature exposure change	1000 hours, $T_A = 150^\circ\text{C}$			± 0.015		%
OUTPUT							
G	Gain	INA790A , INA790B			20		mV/A
G	System Gain Error (shunt + amplifier)	$\text{GND} + 50\text{mV} \leq V_{\text{OUT}} \leq V_S - 200\text{mV}$, $T_A = 25^\circ\text{C}$, $I_{\text{SENSE}} = \pm 50\text{A}$, INA790A		± 0.05	± 0.35	%	
		$\text{GND} + 50\text{mV} \leq V_{\text{OUT}} \leq V_S - 200\text{mV}$, $T_A = 25^\circ\text{C}$, $I_{\text{SENSE}} = \pm 5\text{A}$, INA790A		± 0.05	± 0.35		
		⁽¹⁾ $\text{GND} + 50\text{mV} \leq V_{\text{OUT}} \leq V_S - 200\text{mV}$, $T_A = 25^\circ\text{C}$, $I_{\text{SENSE}} = \pm 50\text{A}$, INA790B		± 0.3	± 1		
		$\text{GND} + 50\text{mV} \leq V_{\text{OUT}} \leq V_S - 200\text{mV}$, $T_A = 25^\circ\text{C}$, $I_{\text{SENSE}} = \pm 5\text{A}$, INA790B		± 0.1	± 0.625		
G	System Gain Error Drift (shunt + amplifier)	$T_A = -40^\circ\text{C to } +125^\circ\text{C}$, INA790A		± 0.5	± 35	$\text{ppm}/^\circ\text{C}$	
		$T_A = -40^\circ\text{C to } +125^\circ\text{C}$, INA790B		± 10	± 100		
	Power Coefficient Gain Non-Linearity Error	⁽²⁾ $\text{GND} + 10\text{mV} \leq V_{\text{OUT}} \leq V_S - 200\text{mV}$			1.5		ppm/A^2

INA790B

SBOSAA6A – MAY 2024 – REVISED DECEMBER 2024

 at $T_A = 25^\circ\text{C}$, $V_S = 5\text{V}$, $I_{\text{SENSE}} = I_{\text{S}+} = 0\text{A}$, $V_{\text{CM}} = V_{\text{IN-}} = 48\text{V}$, $V_{\text{FB}} = V_{\text{OUT}}$ (Adjustable Gain = 1), and $V_{\text{REF}} = V_S / 2$ (unless otherwise noted)

PARAMETER		TEST CONDITIONS	MIN	TYP	MAX	UNIT
RVRR	Reference voltage rejection ratio (input - referred)	$V_{\text{REF}} = 0.5\text{V to } 4.5\text{V}$		± 2.5	± 12.5	mA/V
	Maximum Capacitive Load	No sustained oscillation		0.5		nF
VOLTAGE OUTPUT						
	Swing to V_S Power Supply Rail	$R_L = 10\text{k}\Omega$ to GND, $V_{\text{REF}} = V_S$, Adjustable Gain = 4, $T_A = -40^\circ\text{C to } +125^\circ\text{C}$		$V_S - 0.05$	$V_S - 0.1$	V
	Swing to Ground	$R_L = 10\text{k}\Omega$ to GND, $V_{\text{REF}} = \text{GND}$, Adjustable Gain = 4, $T_A = -40^\circ\text{C to } +125^\circ\text{C}$		$V_{\text{GND}} + 5$	$V_{\text{GND}} + 10$	mV
	Swing to Ground	$R_L = 10\text{k}\Omega$ to GND, $V_{\text{REF}} = \text{GND}$, $T_A = -40^\circ\text{C to } +125^\circ\text{C}$		$V_{\text{GND}} + 1$	$V_{\text{GND}} + 5$	mV
FREQUENCY RESPONSE						
BW	Bandwidth (current sense amplifier only)	-3dB Bandwidth, $V_{\text{FB}} = V_{\text{OUT}}$		1		MHz
		-3dB Bandwidth, Adjustable Gain = 4		0.5		MHz
	Propagation delay ⁽³⁾	$V_{\text{IN+}}, V_{\text{IN-}} = 48\text{V}$, Adjustable Gain = 1, $V_{\text{REF}} = 150\text{mV}$, Load Step = 0A to 20A		0.250		μs
	Total Settling time (current in to out)	$V_{\text{IN+}}, V_{\text{IN-}} = 48\text{V}$, Adjustable Gain = 1, $V_{\text{REF}} = 150\text{mV}$, Load Step = 0A to 20A, Output settles to 1%		5		μs
SR	Slew Rate	$V_{\text{FB}} = V_{\text{OUT}}$		1.8		V/ μs
		Adjustable Gain = 4		1.5		V/ μs
NOISE						
	Current Noise Density			150		$\mu\text{A}/\sqrt{\text{Hz}}$
POWER SUPPLY						
I_Q	Quiescent current			3.5	4.25	mA
		$T_A = -40^\circ\text{C to } +125^\circ\text{C}$			4.5	mA
TEMPERATURE						
T_{Alert}	Thermal Alert Threshold	$R_{\text{pullup}} = 10\text{k}\Omega$,		160		$^\circ\text{C}$
$V_{\text{OL-Alert}}$	Thermal Alert Low-level output voltage	$R_{\text{pullup}} = 10\text{k}\Omega$,			200	mV

(1) This is inclusive of Power Coefficient Gain Non-linearity Error

 (2) $I_{\text{SENSE}} = \pm 5\text{A to } \pm 50\text{A}$, $V_{\text{OUT}} = V_{\text{REF}} \pm 1\text{V}$

(3) Propagation delay is difference of time between 10% of load step to 10% of final output settling value

5.6 Typical Characteristics

at $T_A = 25^\circ\text{C}$, $V_S = 5\text{V}$, $I_{\text{SENSE}} = I_{\text{S}+} = 0\text{A}$, $V_{\text{CM}} = 48\text{V}$, $V_{\text{FB}} = V_{\text{OUT}}$, and $V_{\text{REF}} = V_S / 2$ (unless otherwise noted)

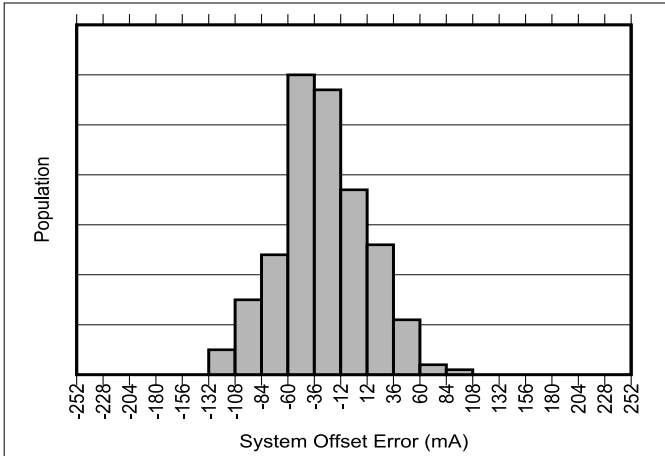

Figure 5-1. INA790B Input Offset Current Production Distribution

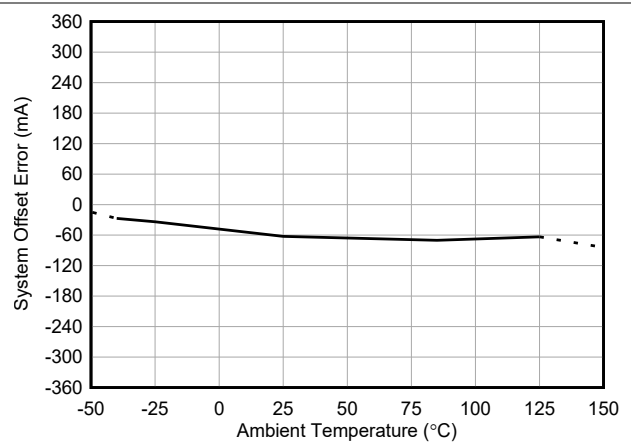

Figure 5-2. INA790B Input Offset Current vs Temperature

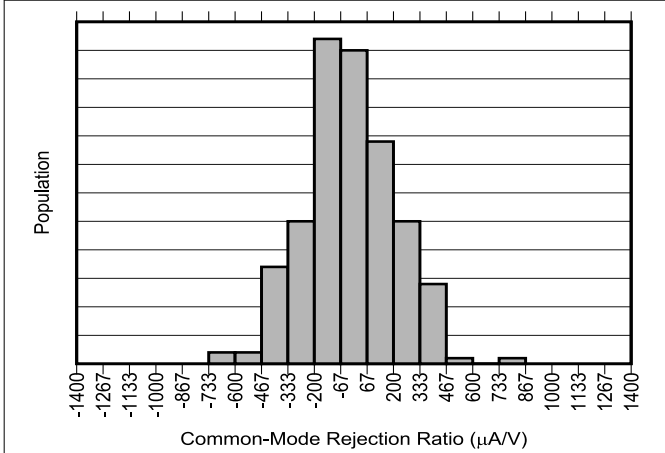

Figure 5-3. INA790B Common-Mode Rejection Production Distribution

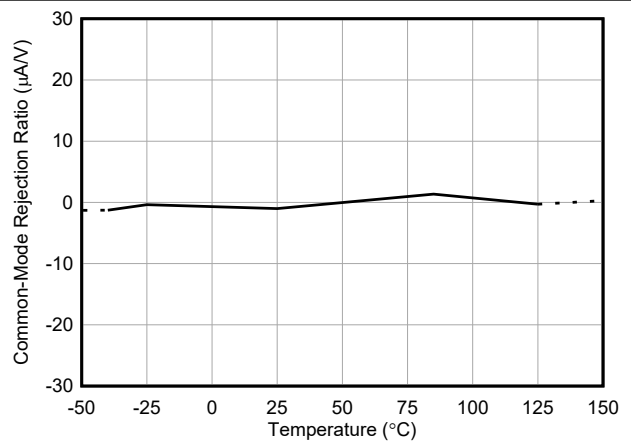

Figure 5-4. Common-Mode Rejection Ratio vs Temperature

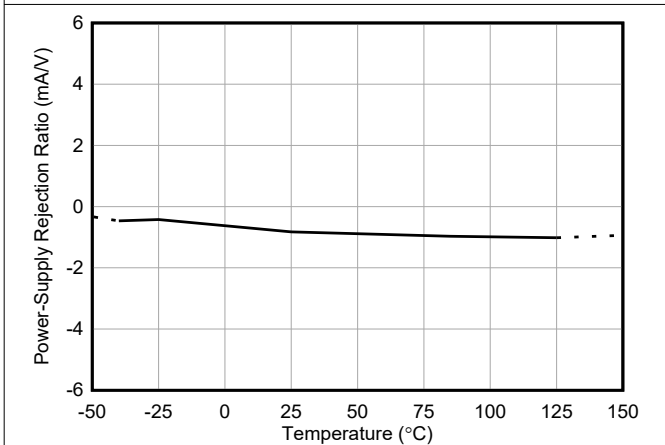

Figure 5-5. Power-Supply Rejection Ratio vs Temperature

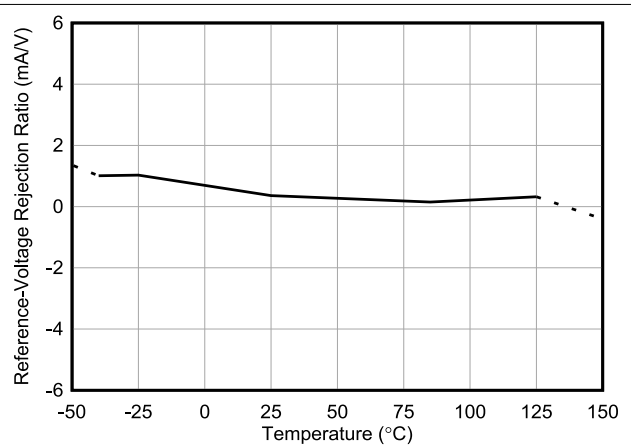

Figure 5-6. Reference Voltage Rejection Ratio vs Temperature

5.6 Typical Characteristics (continued)

at $T_A = 25^\circ\text{C}$, $V_S = 5\text{V}$, $I_{\text{SENSE}} = I_{S+} = 0\text{A}$, $V_{\text{CM}} = 48\text{V}$, $V_{\text{FB}} = V_{\text{OUT}}$, and $V_{\text{REF}} = V_S / 2$ (unless otherwise noted)

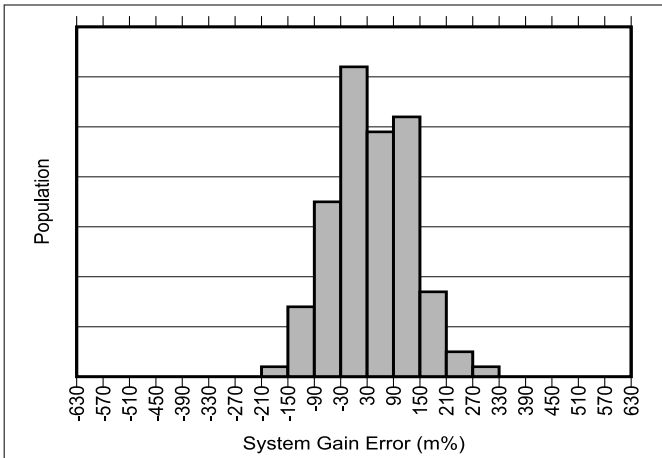

Figure 5-7. INA790B Gain Error Production Distribution

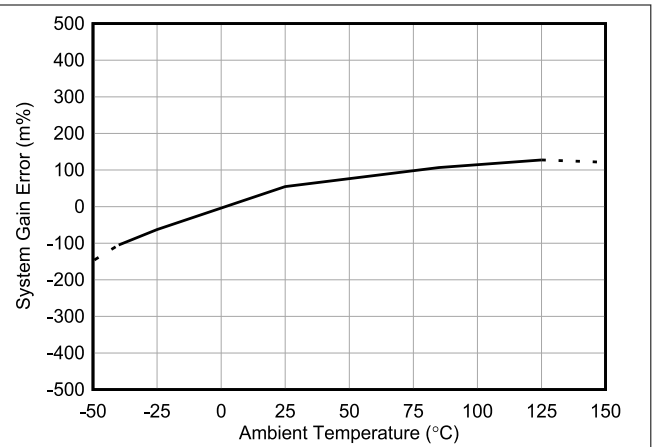

Figure 5-8. INA790B Gain Error vs Temperature

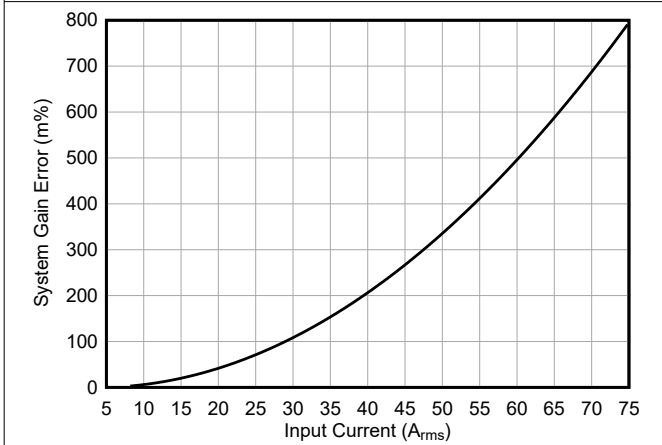

Figure 5-9. INA790B System Gain Error vs Input Current

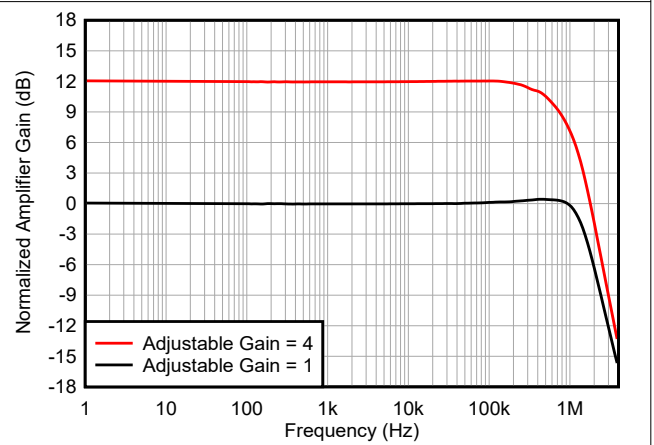

Figure 5-10. Current Sense Amplifier Gain vs Frequency

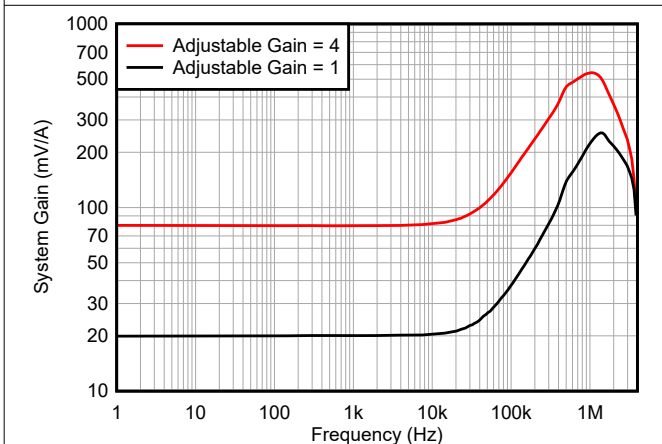

Figure 5-11. System Gain vs Frequency

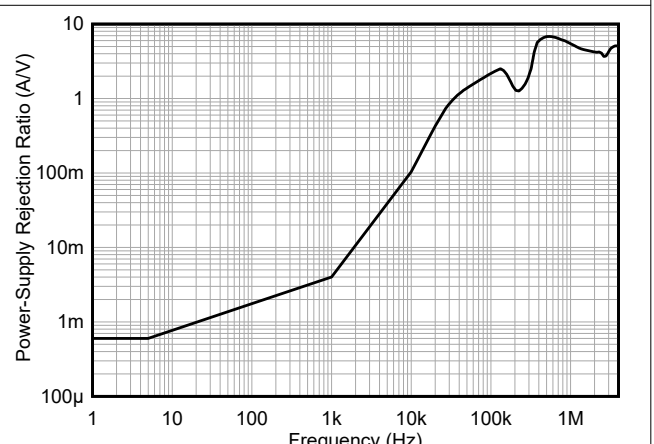

Figure 5-12. Power-Supply Rejection Ratio vs Frequency

5.6 Typical Characteristics (continued)

at $T_A = 25^\circ\text{C}$, $V_S = 5\text{V}$, $I_{\text{SENSE}} = I_{S+} = 0\text{A}$, $V_{\text{CM}} = 48\text{V}$, $V_{\text{FB}} = V_{\text{OUT}}$, and $V_{\text{REF}} = V_S / 2$ (unless otherwise noted)

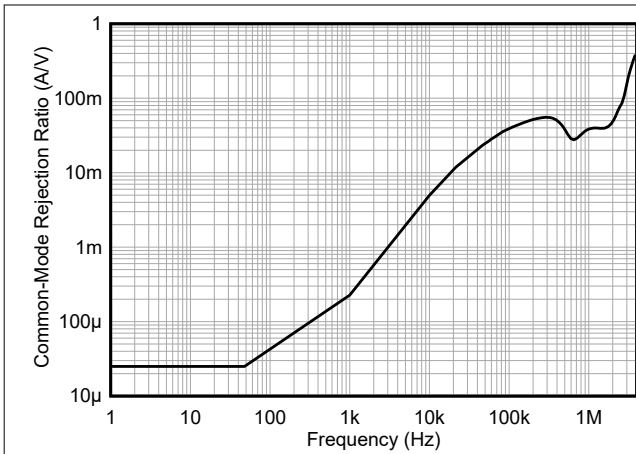

Figure 5-13. Common-Mode Rejection Ratio vs Frequency

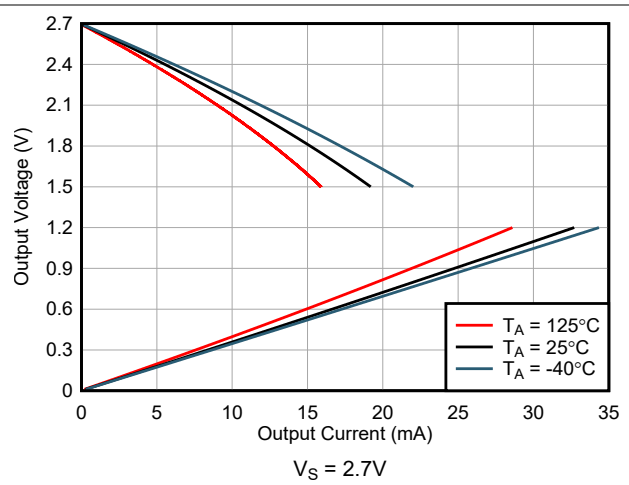

Figure 5-14. Output Voltage Swing vs Output Current

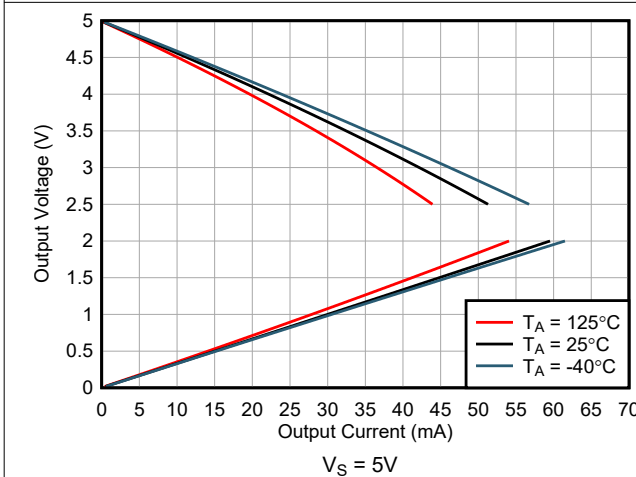

Figure 5-15. Output Voltage Swing vs Output Current

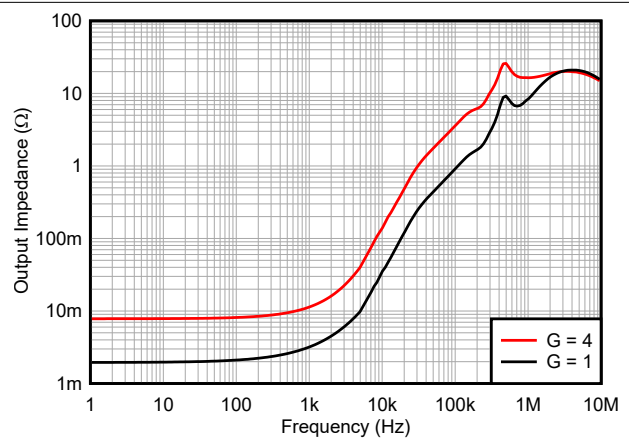

Figure 5-16. Output Impedance vs Frequency

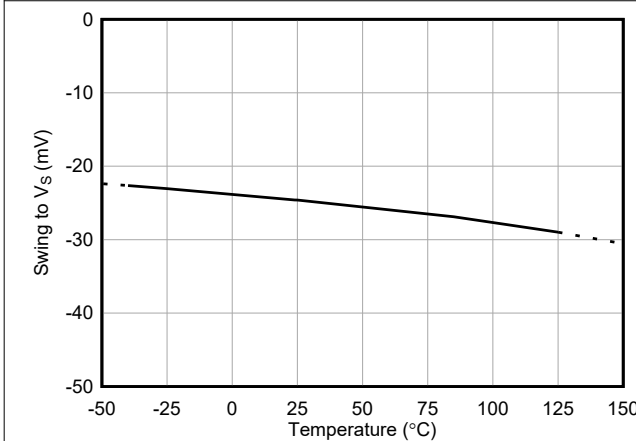

Figure 5-17. Output Voltage Swing High vs Temperature

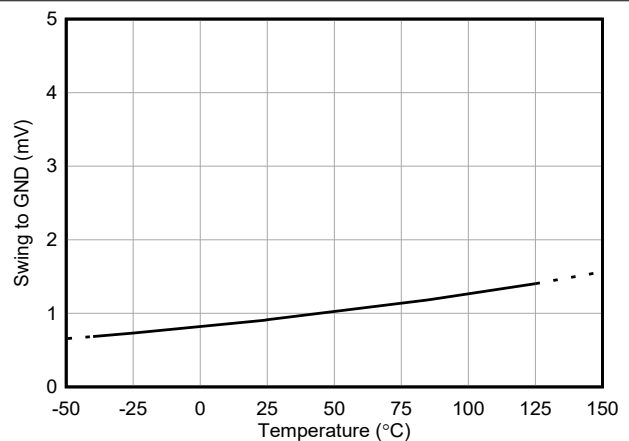

Figure 5-18. Output Voltage Swing Low vs Temperature

5.6 Typical Characteristics (continued)

at $T_A = 25^\circ\text{C}$, $V_S = 5\text{V}$, $I_{\text{SENSE}} = I_{S+} = 0\text{A}$, $V_{\text{CM}} = 48\text{V}$, $V_{\text{FB}} = V_{\text{OUT}}$, and $V_{\text{REF}} = V_S / 2$ (unless otherwise noted)

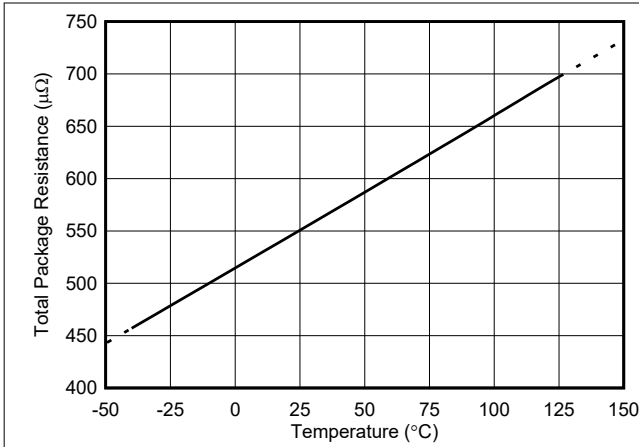

Figure 5-19. Package Resistance vs Temperature

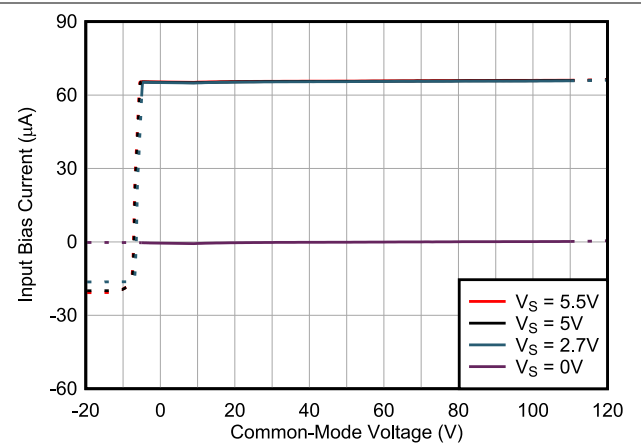

Figure 5-20. Total Input Bias Current vs Common-Mode Voltage

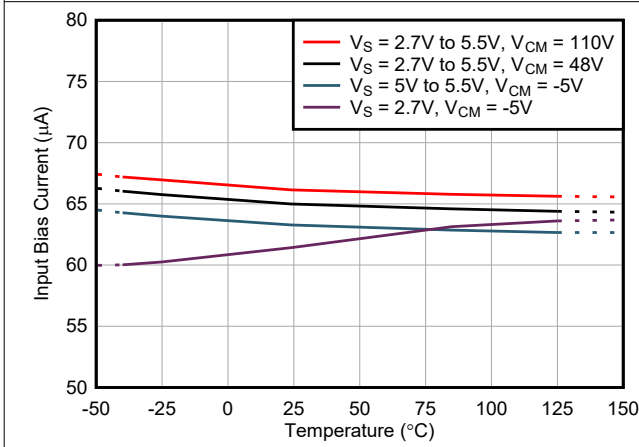

Figure 5-21. Total Input Bias Current vs Temperature

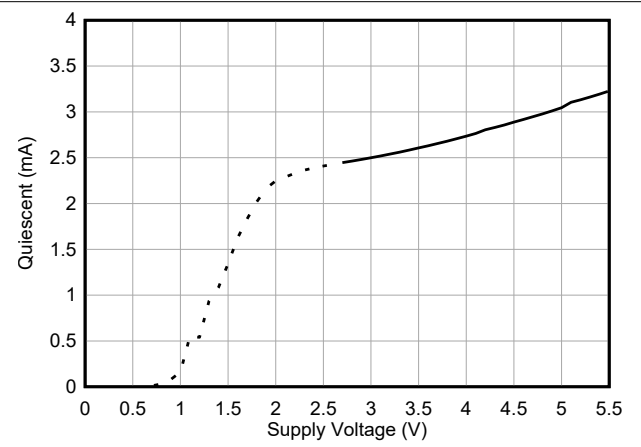

Figure 5-22. Quiescent Current vs Supply Voltage

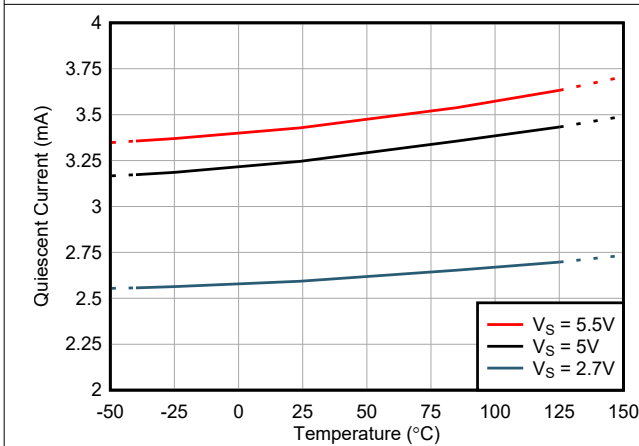

Figure 5-23. Quiescent Current vs Temperature

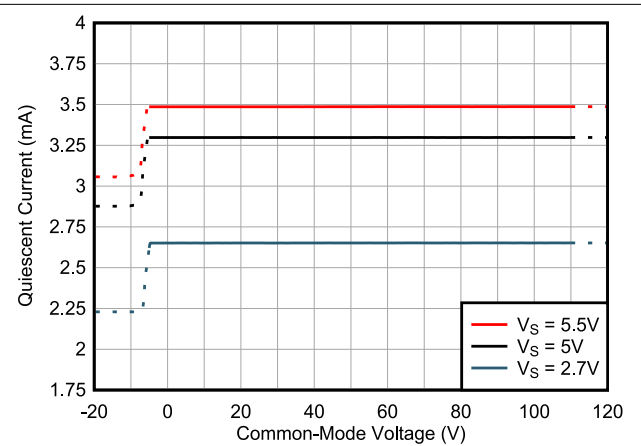
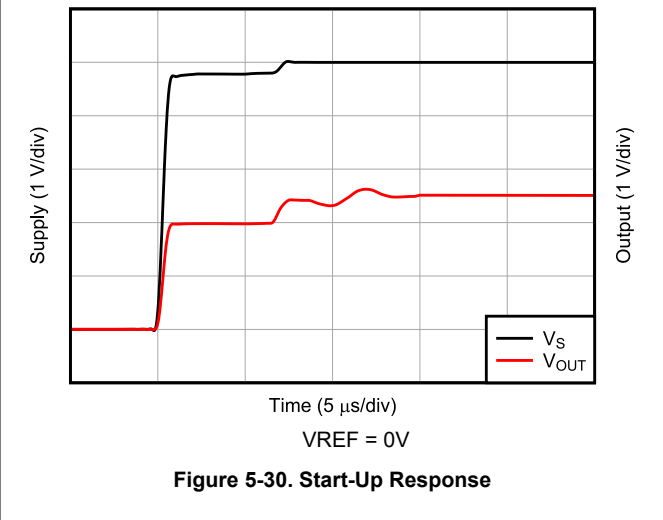
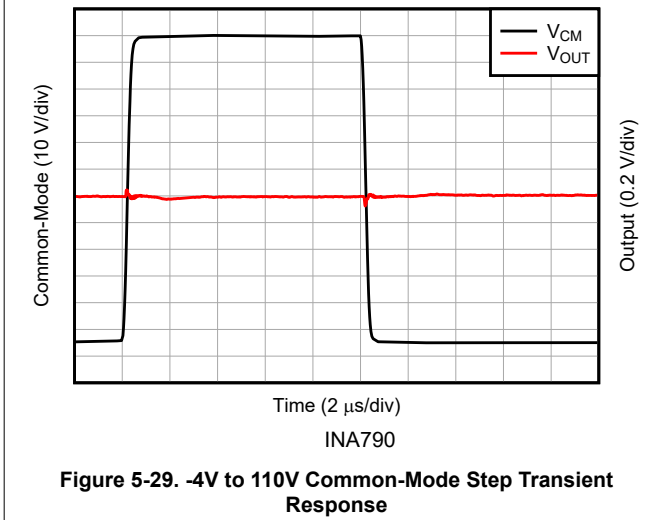
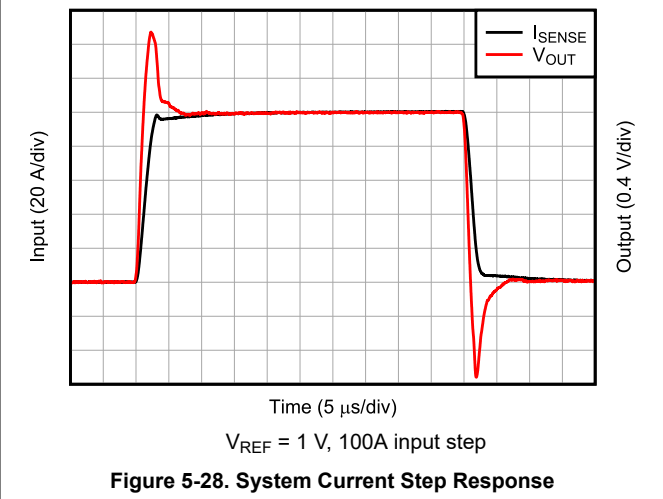
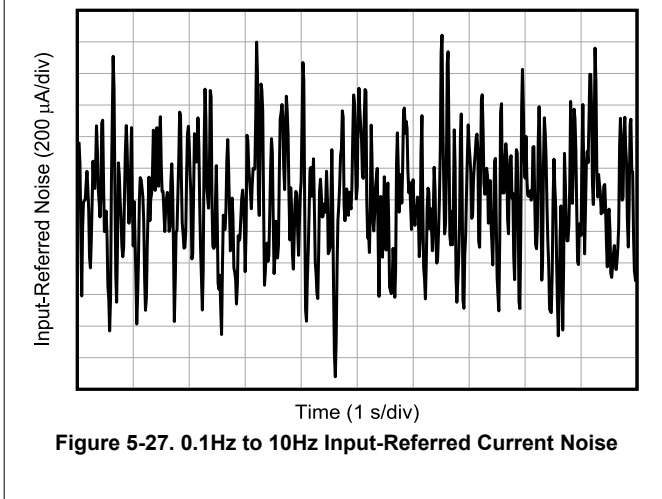
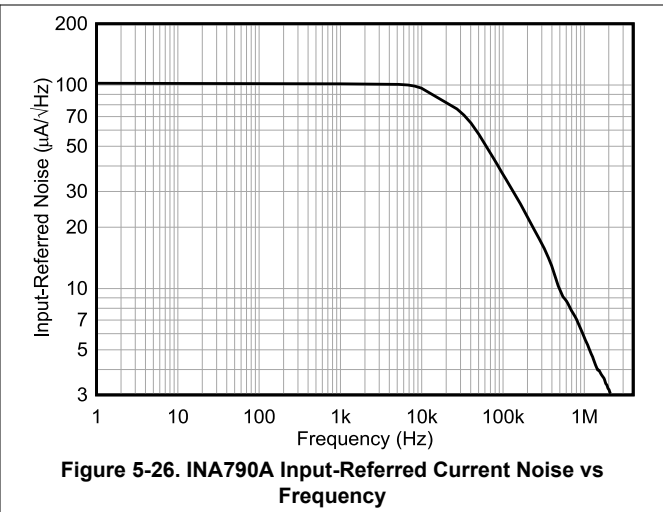
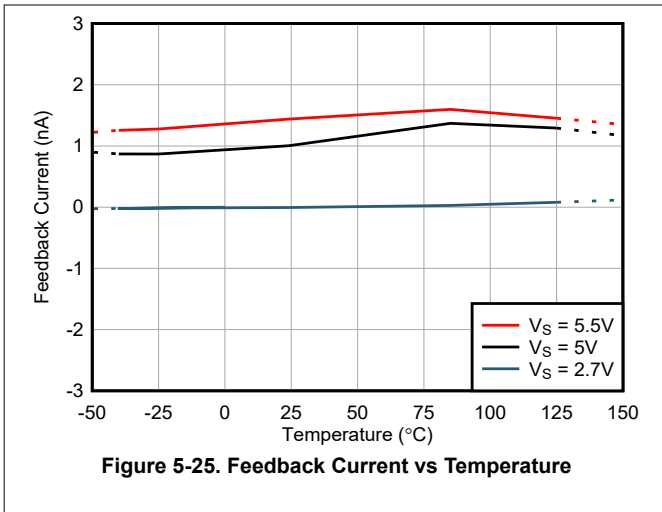

Figure 5-24. Quiescent Current vs Common-Mode Voltage

5.6 Typical Characteristics (continued)

at $T_A = 25^\circ\text{C}$, $V_S = 5\text{V}$, $I_{\text{SENSE}} = I_{S+} = 0\text{A}$, $V_{\text{CM}} = 48\text{V}$, $V_{\text{FB}} = V_{\text{OUT}}$, and $V_{\text{REF}} = V_S / 2$ (unless otherwise noted)



6 Detailed Description

6.1 Overview

The INA790x features a precision current sensing solution with $400\mu\Omega$ current-sensing EZShunt™ technology resistor and supports common-mode voltages up to 110V. The internal amplifier features a precision zero-drift topology with excellent common-mode rejection ratio (CMRR) and enhanced pulse-width modulation (PWM) rejection. Enhanced PWM rejection reduces the effect of common-mode transients on the output signal that are associated with PWM signals in switching systems. High-precision measurements are enabled by matching the shunt resistor value and the current-sensing amplifier gain across temperature, thus providing a highly-accurate, system-calibrated method for measuring current. Flexibility of adjustable gain with two external resistors allows for the optimization of the desired full-scale output voltage based on the target current range expected in the application.

6.2 Functional Block Diagram

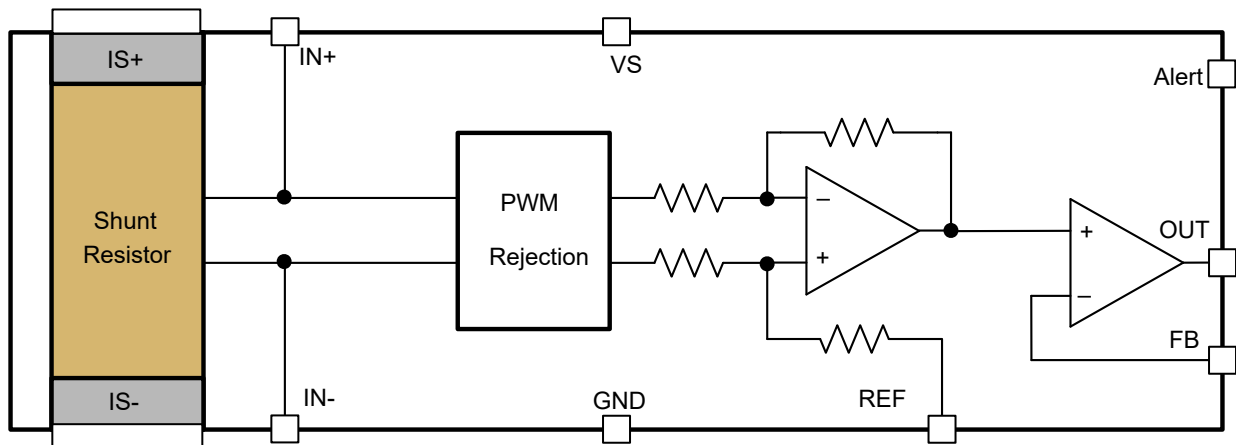

6.3 Feature Description

6.3.1 Integrated Shunt Resistor

The INA790x features an integrated EZShunt™ technology current-sensing resistor that provides accurate measurements over the entire specified temperature range of -40°C to $+125^{\circ}\text{C}$. The integrated current-sensing resistor provides measurement stability over temperature, and simplifies printed circuit board (PCB) layout and board constraint difficulties common in high-precision measurements.

The onboard current-sensing resistor is designed as a 4-wire (or Kelvin) connected resistor that enables accurate measurements through a force-sense connection. Amplifier input pins (IN– and IN+) connected internally to the sense point of the shunt resistor eliminates many instances of parasitic impedance commonly found in typical very-low sensing-resistor level measurements. The INA790x is system-calibrated to make sure that the current-sensing resistor and current-sensing amplifier are both precisely matched to one another. The in-package integrated sensing resistor must be used with the internal current-sensing amplifier to achieve the optimized system gain specification.

The INA790x has approximately $550\mu\Omega$ of package resistance. Of this total package resistance, $400\mu\Omega$ resistance from the Kelvin-connected current-sensing resistor is used by the amplifier. The power dissipation requirements of the system and package are based on the total $550\mu\Omega$ package resistance between the IS+ and IS– pins.

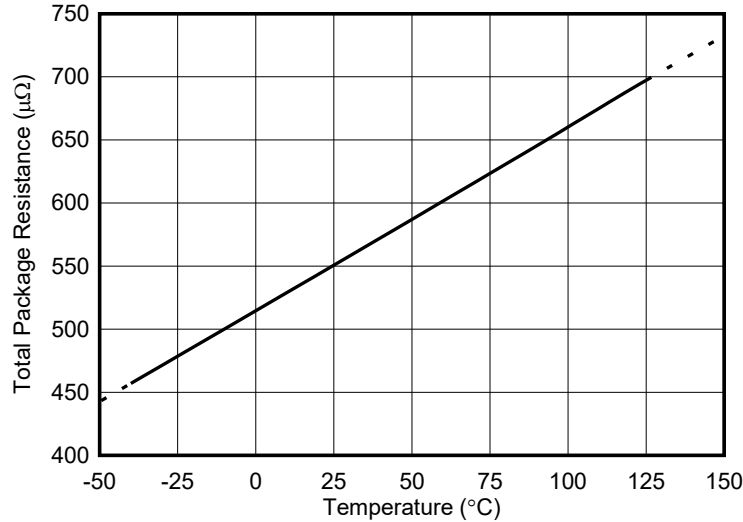

Figure 6-1. IS+ to IS- Package Resistance vs Temperature

6.3.2 Safe Operating Area

The heat dissipated across the package when current flows through the device ultimately determines the maximum current that can be safely handled by the package. The current consumption of the silicon is relatively low, leaving the total package resistance to carry the high load current as the primary contributor to the total power dissipation of the package. The maximum safe-operating current level shown in Figure 6-2 is set to make sure that the heat dissipated across the package is limited so that no damage occurs to the resistor or the package, or that the internal junction temperature of the silicon does not exceed a 165°C limit.

External factors, such as ambient temperature, external air flow, and PCB layout, contribute to how effectively the device dissipates heat. The internal heat is developed as a result of the current flowing through the total package resistance of 550μΩ.

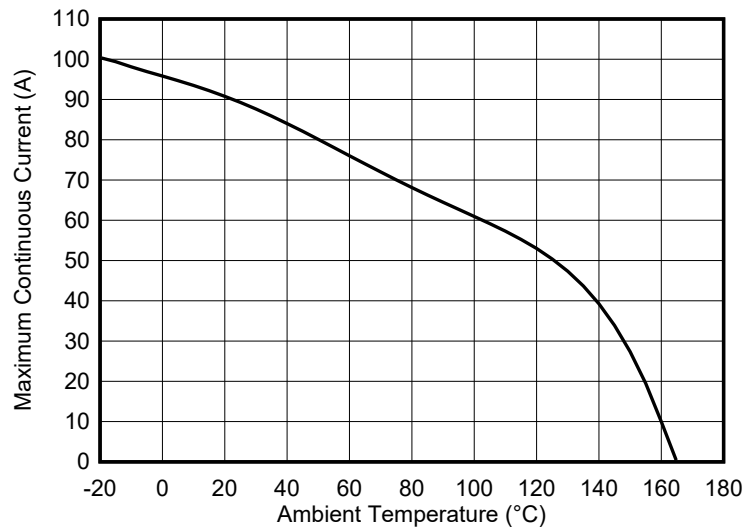

Figure 6-2. Maximum Continuous Current vs Ambient Temperature

6.3.3 Short-Circuit Duration

The INA790x features a physical shunt resistance that is able to withstand current levels higher than the continuous handling limit of 50A without sustaining damage to the current-sensing resistor or the current-sensing amplifier, if the excursions are brief. Figure 6-3 shows the short-circuit duration curve for the INA790x.

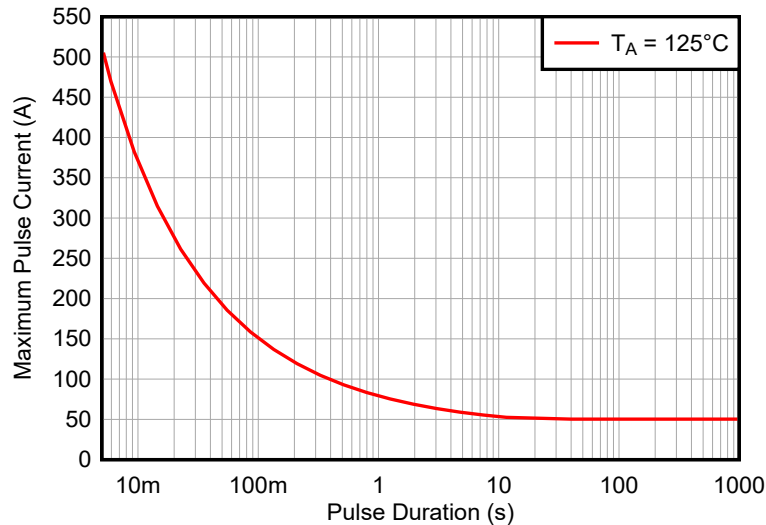

Figure 6-3. Maximum Pulse Current vs Pulse Duration (Single Event)

6.3.4 Temperature Drift Correction

System calibration is common for many industrial applications to eliminate initial component and system-level errors that can be present. A system-level calibration reduces the initial accuracy requirement for many of the individual components because the errors associated with these components are effectively eliminated through the calibration procedure. This calibration enables precise measurements at the temperature in which the system is calibrated. As the system temperature changes because of external ambient changes or self heating, measurement errors are reintroduced. Without accurate temperature compensation used in addition to the initial adjustment, the calibration procedure is not effective. The user must account for temperature-induced changes. The built-in programmed temperature compensation in the INA790x (including both the integrated current-sensing resistor and current-sensing amplifier) keep the device measurement accurate, even when the temperature changes throughout the specified temperature range of the device.

6.3.5 Enhanced PWM Rejection Operation

The enhanced PWM rejection feature of the INA790x provides increased attenuation of large common-mode $\Delta V/\Delta t$ transients. Large $\Delta V/\Delta t$ common-mode transients associated with PWM signals are employed in applications such as motor or solenoid drive and switching power supplies. The disturbances that can occur at the output of a current sense amplifier from common-mode transients causes erroneous measurements and impose limitations when the output is valid. The INA790x is designed with high common-mode rejection techniques to reduce large $\Delta V/\Delta t$ transients before the system is disturbed. As a result, this makes system design simple with INA790x. The high AC CMRR, in conjunction with signal bandwidth, allows the INA790x to minimize output disturbances and ringing during common-mode transitions when compared against traditional current-sensing amplifiers. [Figure 6-4](#) shows the INA790x PWM enhancement performance.

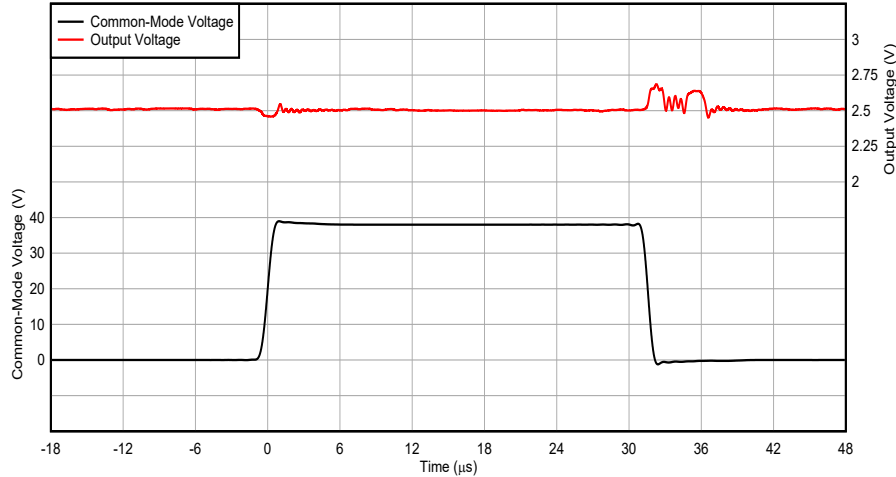

Figure 6-4. Enhanced PWM Rejection Performance

6.4 Device Functional Modes

6.4.1 Adjusting the Output With the Reference Pin

The INA790x output is configurable to allow for unidirectional or bidirectional operation. Figure 6-5 shows a circuit for setting output with an external reference.

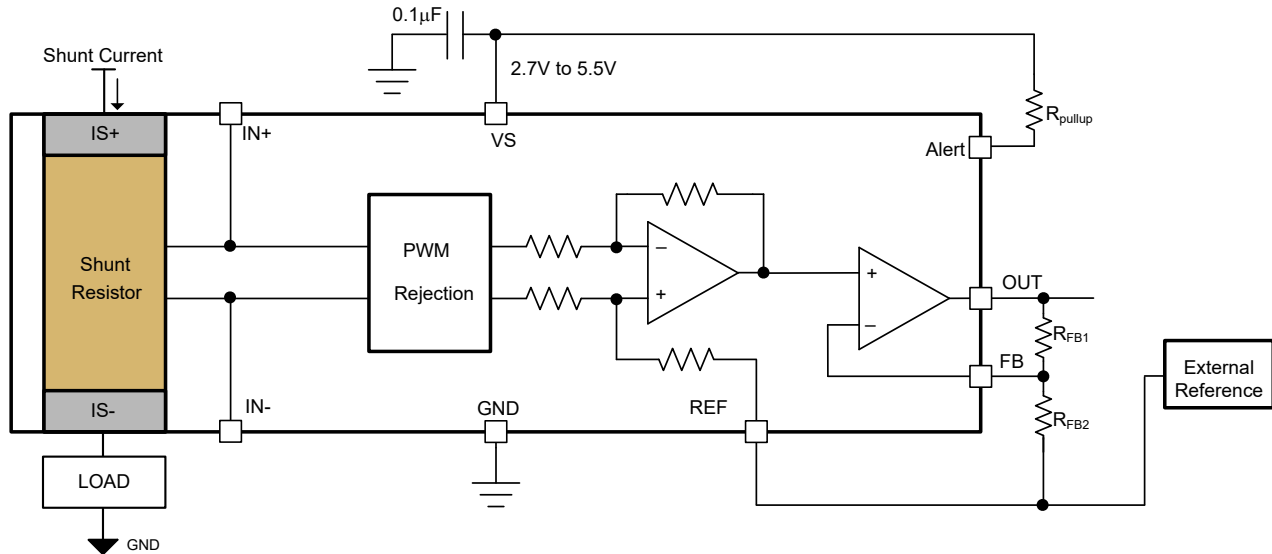

Figure 6-5. Adjusting the Output

The output voltage is set by applying a voltage from an external reference at REF. The reference input is connected to internal gain network. The external resistor network of R_{FB1} and R_{FB2} , connected to OUT, FB and REF pins, set up adjustable gain as explained in [Adjustable Gain Set Using External Resistors](#). Output is set accurately at the voltage provided by external reference as shown in [Equation 1](#) when the resistor R_{FB2} is connected to the same voltage as REF pin. The voltage at REF pin can range between supply V_S and GND. For symmetric bidirectional current sensing REF is set at mid-supply which sets out at mid-supply as well.

$$V_{OUT} = G \times (I_{SHUNT}) + V_{REF} \quad (1)$$

6.4.1.1 Reference Pin Connections for Unidirectional Current Measurements

Unidirectional operation allows current measurements through a resistive shunt in one direction. For unidirectional operation, connect the device reference pin to the negative rail (see the [Ground Referenced](#)

Output section) or positive rail, V_S . The required differential input polarity depends on the output voltage setting. The amplifier output moves away from the referenced rail proportional to the current passing through the internal shunt resistor.

6.4.1.2 Ground Referenced Output

When using the INA790x in unidirectional mode with a ground-referenced output, both REF input and resistor R_{FB2} are connected to ground. [Figure 6-6](#) shows how this configuration takes the output to ground when there is 0A flowing across the internal shunt.

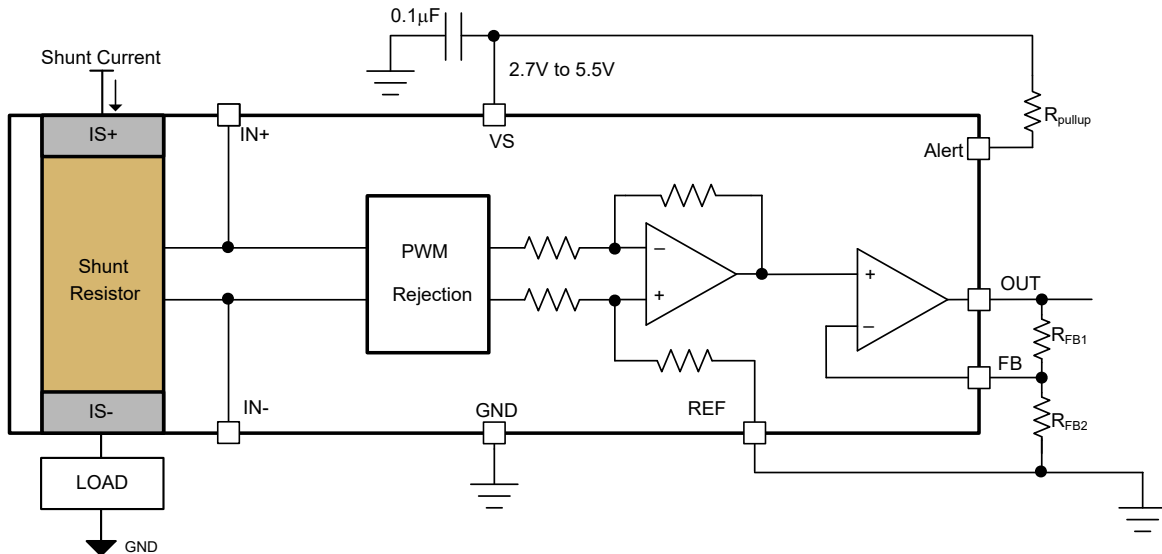

Figure 6-6. Ground-Referenced Output

6.4.1.3 Reference Pin Connections for Bidirectional Current Measurements

Bidirectional operation allows the INA790x to measure currents through a resistive shunt in two directions. For this case, set the output voltage anywhere within the reference input limits. A common configuration is to set the reference inputs at half-scale for equal range in both directions. However, the reference input can be set to a voltage other than half-scale when the bidirectional current is nonsymmetrical.

6.4.1.4 Output Set to Mid-Supply Voltage

[Figure 6-7](#) shows two equal resistors R_1 and R_2 connected between V_S and the GND pins divide the supply at half, and by connecting REF pin to the divided supply, output is set to mid-supply voltage. The mid-point of these resistors is buffered using external operational amplifier to avoid loading of resistors resulting in error. The output is set to middle of the supply when there is no differential input voltage or 0A current in shunt resistor. This method creates a ratiometric offset to the supply voltage, where the output voltage remains at $V_S / 2$ when 0A of current flows through internal shunt resistor.

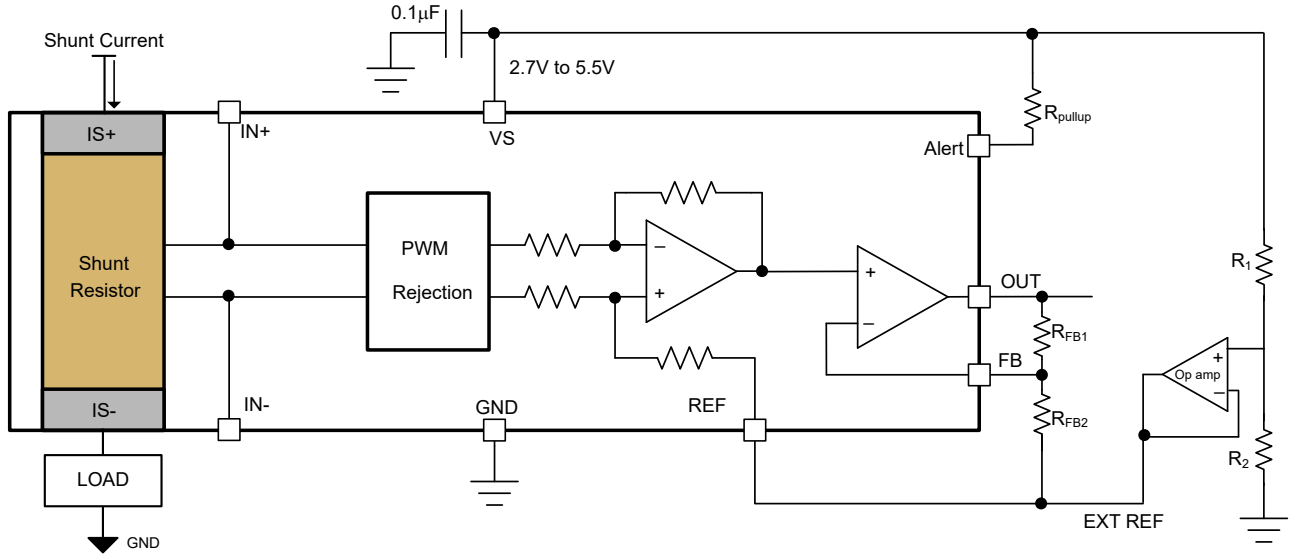

Figure 6-7. Mid-Supply Voltage Output

6.4.2 Adjustable Gain Set Using External Resistors

The INA790x features adjustable gain with two external resistor network. The default gain is 20mV/A, and with added external adjustable gain resistor network, total gain (G) can range up to 400mV/A. Figure 6-8 shows two external resistors R_{FB1} and R_{FB2} configured for added external gain. Equation 2 can be used for calculating external adjustable gain and Equation 3 shows the total gain of the system with external adjustable gain. The REF pin and one end of resistor R_{FB2} is connected to external reference based on needed voltage at OUT pin as described in [Adjusting the Output With the Reference Pin](#).

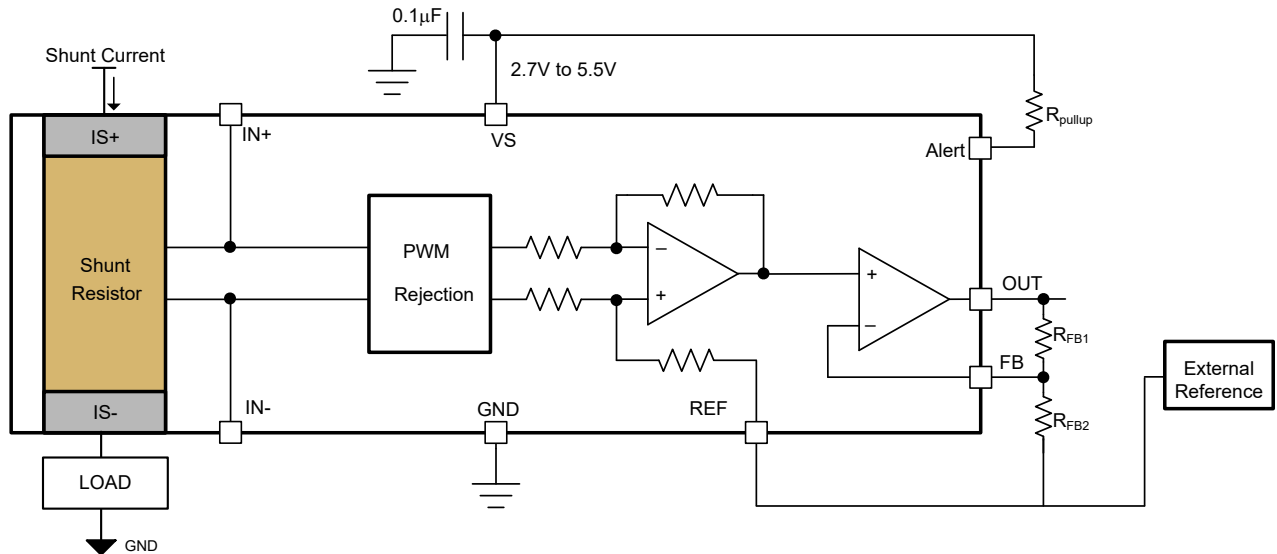

Figure 6-8. Adjustable Gain Setting With External Resistor Divider

$$\text{Adjustable Gain} = \left(1 + \frac{R_{FB1}}{R_{FB2}} \right) \quad (2)$$

$$G = 20 \frac{\text{mA}}{\text{V}} \times \left(1 + \frac{R_{FB1}}{R_{FB2}} \right) \quad (3)$$

The FB pin in INA790x has associated bias current, which can add to error when large values of adjustable gain resistor, R_{FB1} , is used. Alternatively, very low values of adjustable gain resistors load the output of the sense amplifier limiting the capability of the sense amplifier to get close to the supply rail. Keeping the sum of external resistors R_{FB1} and R_{FB2} between $10k\Omega$ and $40k\Omega$ is recommended when external adjustable gain is higher than 1. [Table 6-1](#) shows recommended values of external gain resistors for the most common gains.

Table 6-1. Recommended Values of External Resistors Setting Adjustable Gain

External Adjustable Gain	R_{FB1}	R_{FB2}	Total Gain (G)
1	0Ω (short)	Open	20mV/A
2	$20k\Omega$	$20k\Omega$	40mV/A
4	$30k\Omega$	$10k\Omega$	80mV/A
5	$20k\Omega$	$5k\Omega$	100mV/A

6.4.2.1 Adjustable Unity Gain

[Figure 6-9](#) shows adjustable gain set to unity gain or 1. In this configuration OUT is connected to FB without any external resistor. This unity gain sets INA790x to default minimum gain of 20mV/A. [Equation 3](#) can be used to calculate the total gain of the system. The REF pin is connected to external reference based on needed output voltage setting as described in [Adjusting the Output With the Reference Pin](#).

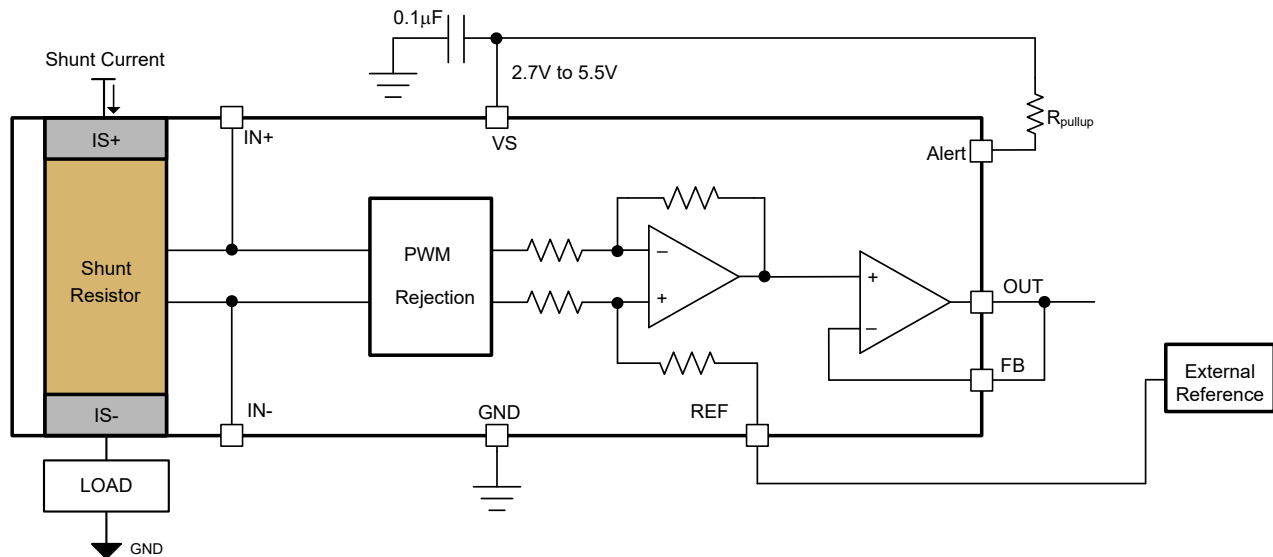

Figure 6-9. Adjustable Unity Gain Setting

6.4.3 Thermal Alert Function

The INA790x has thermal Alert function that provides an alert when internal shunt temperature reaches 160°C . The power dissipation as a result of internal shunt current causes the temperature to rise inside the package. Extended time at temperature higher than 150°C can cause permanent shift in device specification. Thermal alert function can be used to keep the temperature of INA790x below 150°C . [Figure 6-10](#) shows a circuit where R_{pullup} resistor is tied between open-drain Alert pin and the supply pin. When temperature of the INA790x reaches 160°C , the open-drain FET pulls Alert pin to the ground asserting thermal alert.

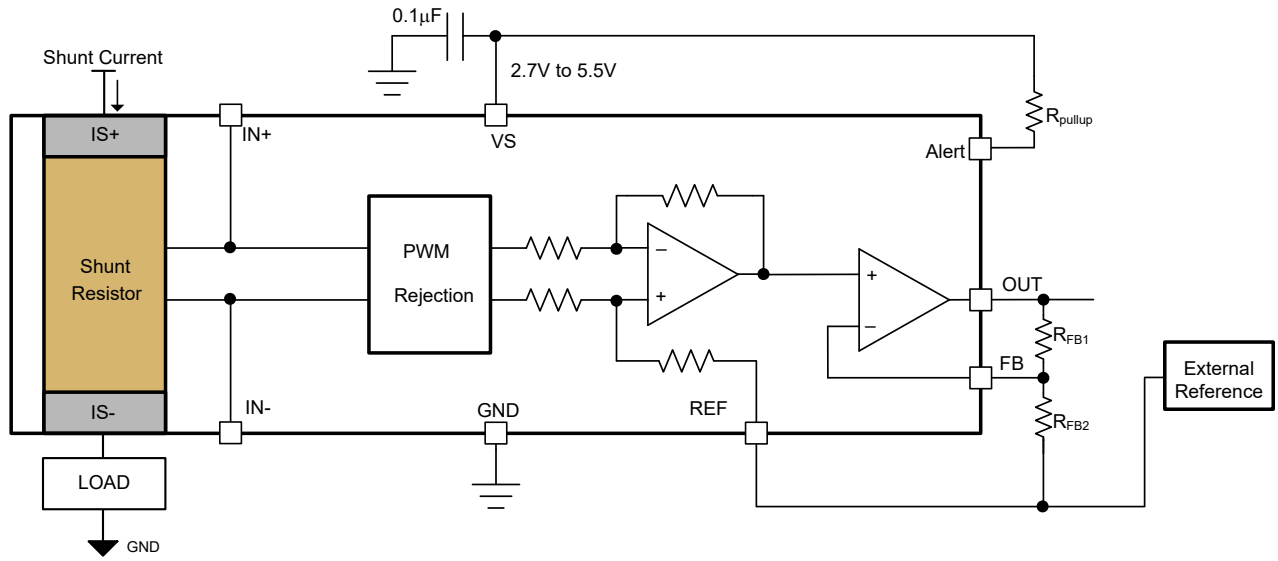

Figure 6-10. Thermal Alert Function

7 Application and Implementation

Note

Information in the following applications sections is not part of the TI component specification, and TI does not warrant its accuracy or completeness. TI's customers are responsible for determining suitability of components for their purposes, as well as validating and testing their design implementation to confirm system functionality.

7.1 Application Information

The INA790x measures the voltage developed as current flows across the integrated current shunt. The device provides a reference pin to configure operation as either unidirectional or bidirectional output swing. When using the INA790x for inline motor current sense or measuring current in an H-bridge, the device is commonly configured for bidirectional operation.

7.1.1 Calculating Total Error

The INA790x electrical specifications [Electrical Characteristics](#) include typical individual errors terms (such as gain error, offset error, and nonlinearity error). Total error, including all of these individual error components, is not specified in the table. To accurately calculate the expected error of the device, the user must first know the device operating conditions. This section discusses the individual error sources and how the device total error value can be calculated from the combination of these errors for specific conditions.

Three examples are provided in [Table 7-1](#), [Table 7-2](#), and [Table 7-3](#) that detail how different operating conditions can affect the total error calculations. Typical and maximum calculations are shown as well to provide the user more information on how much error variance is present from device to device.

7.1.1.1 Error Sources

The typical error sources that have the largest effect on the total error of the device are gain error, nonlinearity, common-mode rejection ratio, and input offset error. For the INA790x, an additional error source (referred to as the *reference voltage rejection ratio*) is also included in the total error value.

7.1.1.2 Reference Voltage Rejection Ratio Error

Reference voltage rejection ratio refers to the amount of error induced by applying a reference voltage to the INA790x that deviates from the mid-point of the device supply voltage.

7.1.1.3 External Adjustable Gain Error

The INA790x features external adjustable gain with two external resistors as described in [Adjustable Gain Set Using External Resistors](#). The tolerance of these external resistors contribute to the total gain error of the system. These resistors are recommended to be of same kind so that temperature drift of these resistor track closely. [Equation 4](#) can be used for calculating total error contributed by two external gain resistors.

$$Error_{G_R} = \sqrt{2} * (Resistor_{Tolerance} + Resistor_{drift} \times \Delta T) \quad (4)$$

7.1.1.4 Total Error Example 1

Table 7-1. Total Error Calculation: Example 1 ⁽¹⁾

TERM	SYMBOL	EQUATION	MAX VALUE
Initial input offset with Temp drift	I_{OS_T}	$I_{OS} + \frac{dI_{OS}}{dT} \times \Delta T$	30mA
Added input offset because of common-mode voltage	I_{OS_CM}	$CMRR \times (V_{CM} - 48V) $	0μA
Added input offset because of reference voltage	I_{OS_REF}	$RVRR \times \left \left(\frac{V_S}{2} - V_{REF} \right) \right $	0μA

Table 7-1. Total Error Calculation: Example 1 ⁽¹⁾ (continued)

TERM	SYMBOL	EQUATION	MAX VALUE
Total input offset Current	I_{OS_Total}	$\sqrt{(I_{OS_T})^2 + (I_{OS_CM})^2 + (I_{OS_REF})^2}$	30mA
Error from input offset	$Error_{I_{OS}}$	$\frac{I_{OS_Total}}{I_{Sense}} \times 100$	0.12%
Gain error with Gain drift	$Error_G$	$G_{Error} + G_{Error_drift} \times \Delta T$	0.35%
Error due to Gain Nonlinearity	$Error_{Lin}$	$G_{Lin_Error} \times I^2 * 100\%$	0.0937%
Total error	—	$\sqrt{(Error_{I_{OS}})^2 + (Error_G + Error_{Lin})^2}$	0.46%

(1) The data for [Total Error Example 1](#) is taken with the INA790x, $V_S = 5V$, $V_{CM} = 48V$, $V_{REF} = V_S / 2$, $T = 25^\circ C$, External Unity Gain ($G = 20mV/A$) and $I_{SENSE} = 25A$.

7.1.1.5 Total Error Example 2

Table 7-2. Total Error Calculation: Example 2 ⁽¹⁾

TERM	SYMBOL	EQUATION	MAX VALUE
Initial input offset with Temp drift	I_{OS_T}	$I_{OS} + \frac{dI_{OS}}{dT} \times \Delta T$	92.5mA
Added input offset because of common-mode voltage	I_{OS_CM}	$CMRR \times (V_{CM} - 48V) $	2.8mA
Added input offset because of reference voltage	I_{OS_REF}	$RVRR \times \left \left(\frac{V_S}{2} - V_{REF} \right) \right $	31.25mA
Total input offset Current	I_{OS_Total}	$\sqrt{(I_{OS_T})^2 + (I_{OS_CM})^2 + (I_{OS_REF})^2}$	97.7mA
Error from input offset	$Error_{I_{OS}}$	$\frac{I_{OS_Total}}{I_{Sense}} \times 100$	0.39%
Gain error with Gain drift	$Error_G$	$G_{Error} + G_{Error_drift} \times \Delta T$	0.7%
Error due to Gain Nonlinearity	$Error_{Lin}$	$G_{Lin_Error} \times I^2 * 100\%$	0.0937%
Total error	—	$\sqrt{(Error_{I_{OS}})^2 + (Error_G + Error_{Lin})^2}$	0.885%

(1) The data for [Total Error Example 2](#) is taken with the INA790x, $V_S = 5V$, $V_{CM} = 12V$, $V_{REF} = 0V$, $T = 125^\circ C$, External Unity Gain ($G = 20mV/A$) and $I_{SENSE} = 25A$.

7.1.1.6 Total Error Example 3

Table 7-3. Total Error Calculation: Example 3 ⁽¹⁾

TERM	SYMBOL	EQUATION	MAX VALUE
Initial input offset with Temp drift	I_{OS_T}	$I_{OS} + \frac{dI_{OS}}{dT} \times \Delta T$	92.5mA
Added input offset because of common-mode voltage	I_{OS_CM}	$CMRR \times (V_{CM} - 48V) $	2.8mA
Added input offset because of reference voltage	I_{OS_REF}	$RVRR \times \left \left(\frac{V_S}{2} - V_{REF} \right) \right $	31.25mA
Total input offset Current	I_{OS_Total}	$\sqrt{(I_{OS_T})^2 + (I_{OS_CM})^2 + (I_{OS_REF})^2}$	97.67mA
Error from input offset	$Error_{I_{OS}}$	$\frac{I_{OS_Total}}{I_{Sense}} \times 100$	0.39%
Gain error with Gain drift	$Error_G$	$G_{Error} + G_{Error_drift} \times \Delta T$	0.7%

Table 7-3. Total Error Calculation: Example 3 ⁽¹⁾ (continued)

TERM	SYMBOL	EQUATION	MAX VALUE
Error due to Gain Nonlinearity	Error _{Lin}	$G_{Lin_Error} \times I^2 * 100\%$	0.0937%
External Gain Resistor Error + Drift	Error _{G_R}	Equation 4	0.707%
Total error	—	$\sqrt{(Error_{I_{OS}})^2 + (Error_{G_R})^2 + (Error_G + Error_{Lin})^2}$	1.13%

(1) The data for [Total Error Example 3](#) is taken with the INA790x, V_S = 5V, V_{CM} = 12V, V_{REF} = 0V, T = 125°C, External Gain = 4 (Total Gain = 80mV/A), External Resistor Tolerance = 0.25%, External Resistor Drift = 25ppm/°C and I_{SENSE} = 25A.

7.1.1.7 Total Error Curves

INA790A and INA790B Total Error Curve plots are generated using Total Error Examples for Adjustable Gain of 1 (unity gain).

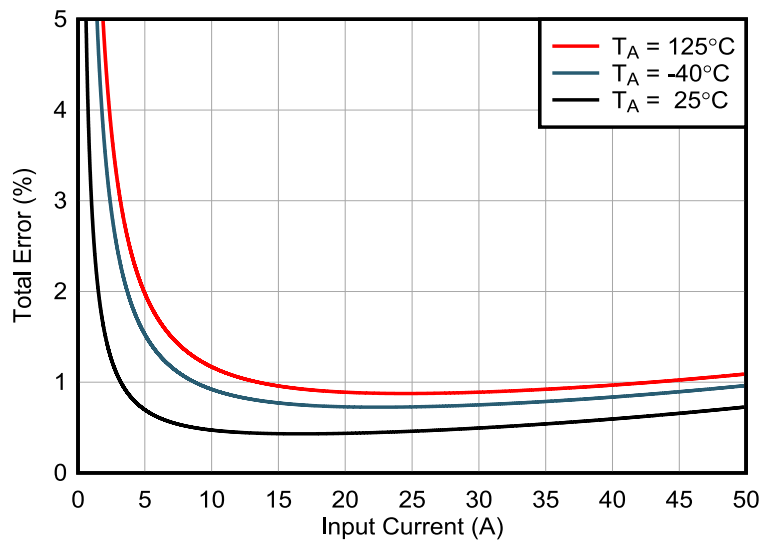

V_{CM} = 48V, V_S = 5V, V_{REF} = 2.5V, Adjustable Gain = 1

Figure 7-1. INA790A Total Error vs Input Current

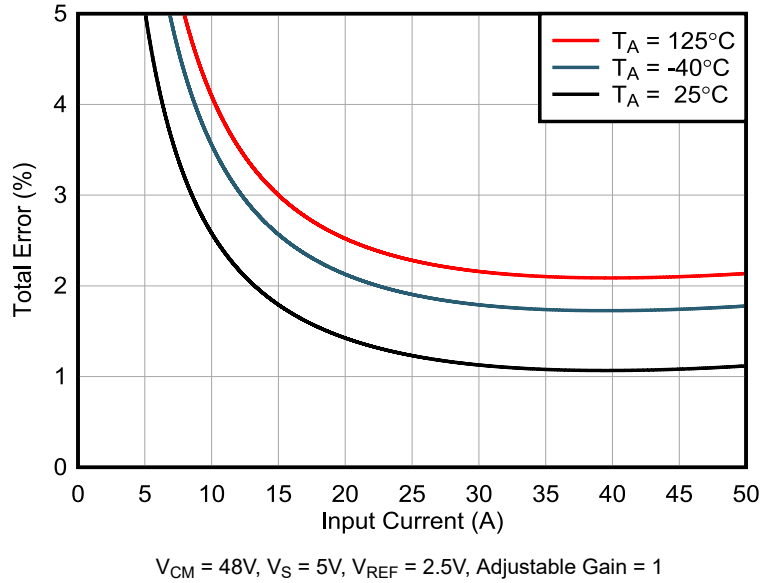

Figure 7-2. INA790B Total Error vs Input Current

7.1.2 Signal Filtering

Note that the integrated sensing element has inductance like all low-ohmic shunt resistors. Shunt inductance can lead to shunt voltage overshoots and AC gain peaking, which is undesirable if system requires linear and accurate current measurements when sensing small signal frequencies beyond 100kHz or when system can not tolerate overshoot from fast current step responses such as when comparators are tracking for fast overcurrent events. Figure 7-3 show INA790x shunt impedance vs frequency.

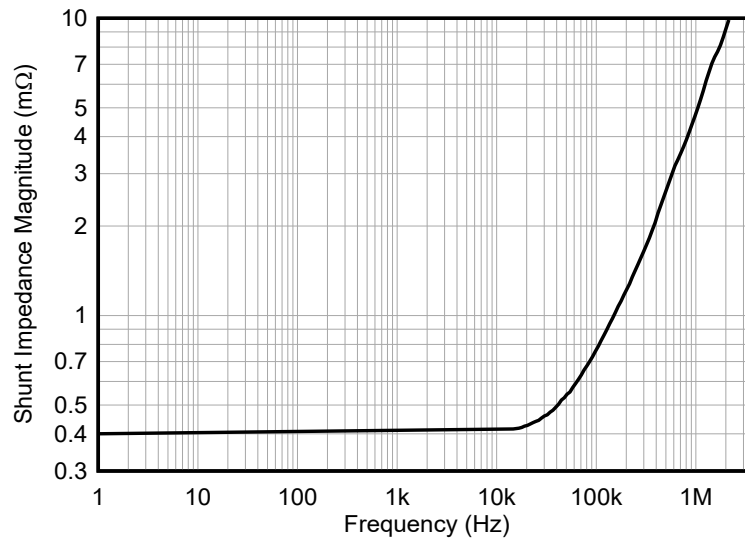

Figure 7-3. Shunt Impedance vs Frequency

Typically, inductance from low-Ohmic shunt resistors can be negated by adding a differential filter that creates a pole to flatten zero introduced from inductance. For the INA790x an internal short is provided from Kelvin sense connections to amplifier input to optimize noise, performance and quality. Thus, input resistance on these connections is very low and to apply an input filter, a capacitance between IN+ and IN- that is greater than 22μF is required. The filter capacitor must be placed as close as possible to IN+ and IN- pins. Figure 7-4 shows gain response versus frequency with and without input filter capacitor.

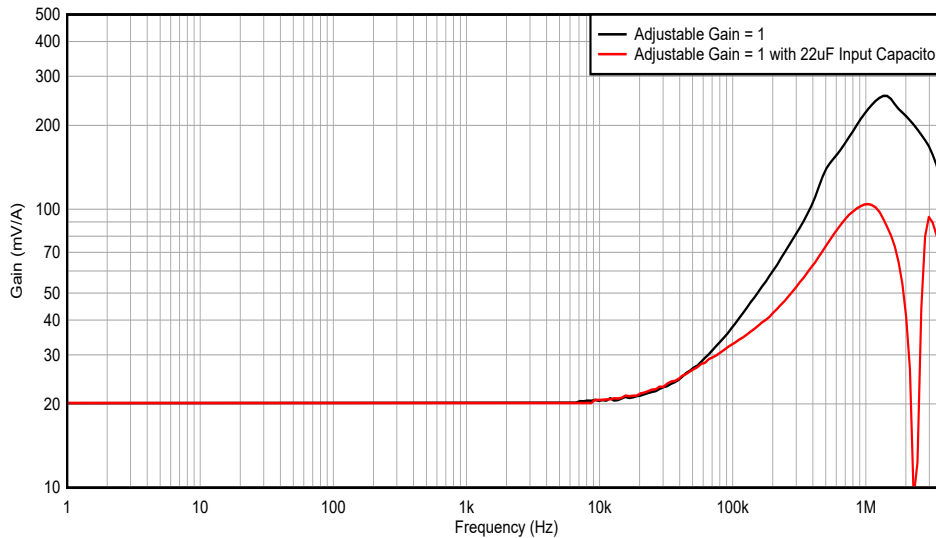

Figure 7-4. INA790x Gain vs Frequency Before and After Adding 22µF Input Capacitor

Another option to negate the shunt inductance is to introduce the zero in transfer function at the adjustable gain-setting output buffer with a circuit configuration referred to as a RISO Dual Feedback. This operational amplifier network provides a zero to cancel out shunt inductance without sacrificing overall bandwidth nor output impedance. Figure 7-5 shows RISO Dual Feedback circuit configuration

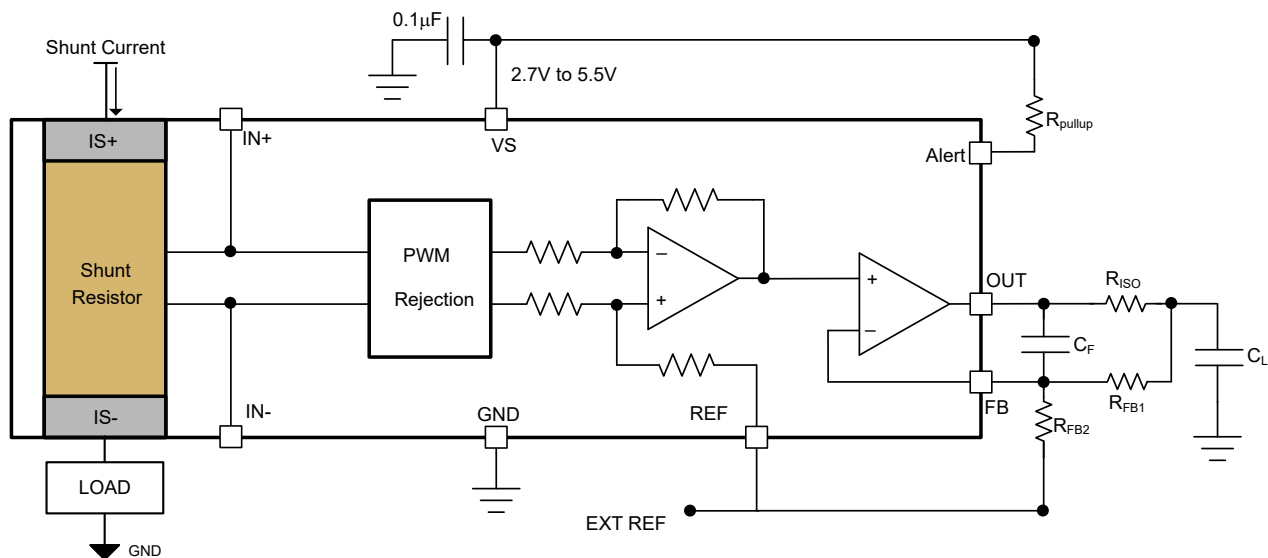

Figure 7-5. INA790x With RISO-Dual-Feedback

Based upon measured bandwidth and output impedance, Table 7-4 shows values for circuit components that can be used to achieve the circuit with the desired gain. Resistor tolerances under 2% is recommended. Figure 7-6 and Figure 7-7 show the load step responses with and without RISO Dual Feedback circuit with the component values in Table 7-4.

Table 7-4. INA790x RISO Dual Feedback Values

Adjustable Gain	Total Gain (mV/A)	R _{FB1}	R _{FB2}	R _{ISO}	C _F	Min C _L
1	20	19.1kΩ	Open	200Ω	10nF	10nF
2	40	19.1kΩ	19.1kΩ	0Ω (Short)	0.1nF	Open
3	60	19.1kΩ	9.76kΩ	0Ω (Short)	0.1nF	Open
4	80	19.1kΩ	6.26kΩ	0Ω (Short)	0.1nF	Open

Table 7-4. INA790x RISO Dual Feedback Values (continued)

Adjustable Gain	Total Gain (mV/A)	R _{FB1}	R _{FB2}	R _{ISO}	C _F	Min C _L
5	100	19.1kΩ	4.7kΩ	0Ω (Short)	0.1nF	Open

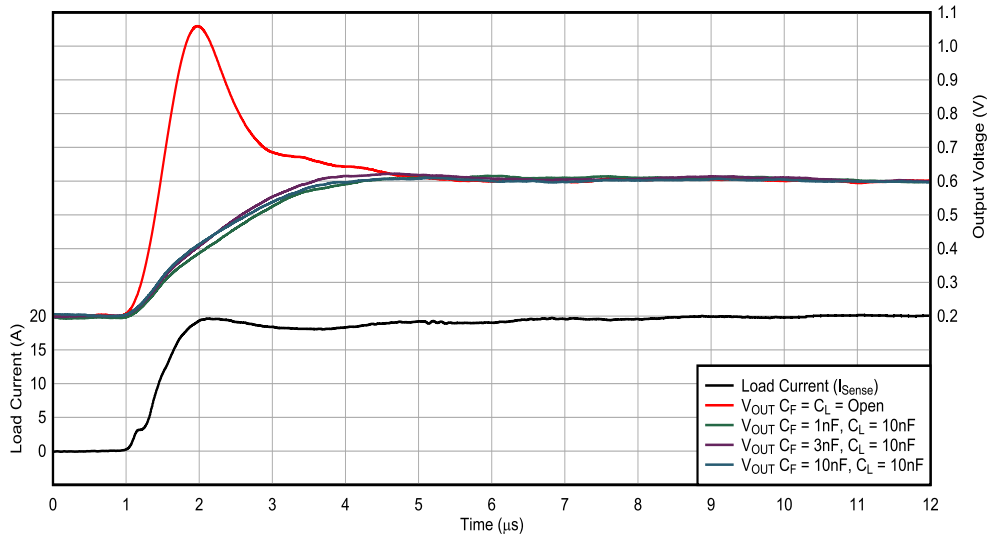

Adjustable Gain = 1, V_{CM} = 20V, V_S = 5V, V_{REF} = 0.2V

Figure 7-6. INA790x Load Step Responses Before and After RISO Dual Feedback for Adjustable Gain of 1

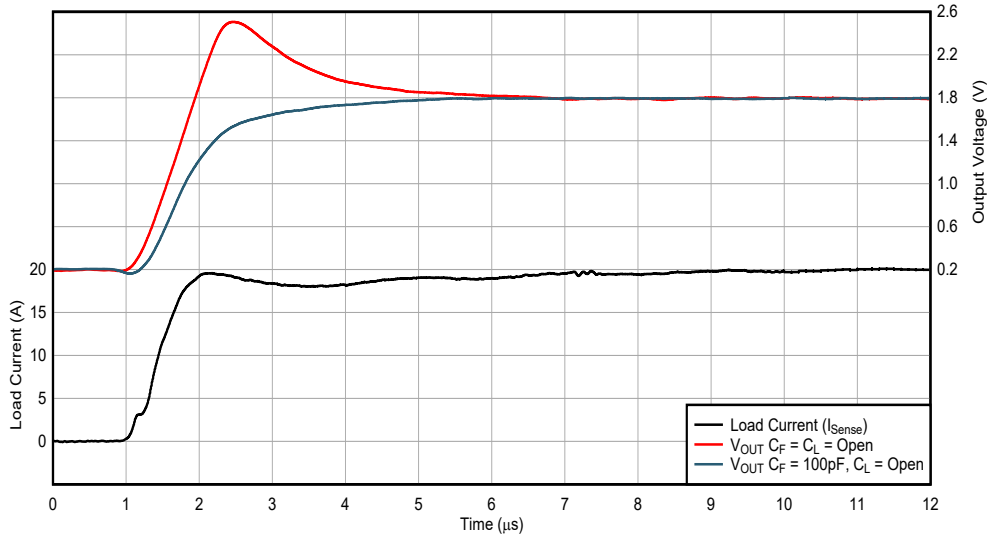

Adjustable Gain = 4, V_{CM} = 20V, V_S = 5V, V_{REF} = 0.2V

Figure 7-7. INA790x Load Step Responses Before and After Feedback Capacitor For Adjustable Gain of 4

7.2 Typical Applications

The INA790x offers advantages for multiple applications including the following:

- High common-mode range and excellent CMRR enables direct inline sensing
- Precision low-inductive, low-drift shunt eliminates the need for overtemperature system calibration
- Ultra-low offset and drift eliminates the necessity of calibration
- Wide supply range enables a direct interface with most microprocessors

7.2.1 High-Side, High-Drive, Solenoid Current-Sense Application

Challenges exist in solenoid drive current sensing that are similar to those in motor inline current sensing. In certain topologies, the current-sensing amplifier is exposed to the full-scale PWM voltage between ground and supply. The INA790x is an excellent choice for this type of application. The 400μΩ integrated shunt with a total system accuracy of 0.35% with a total system drift of 35ppm/°C provides system accuracy across temperature eliminating the need for system calibration at multiple temperatures.

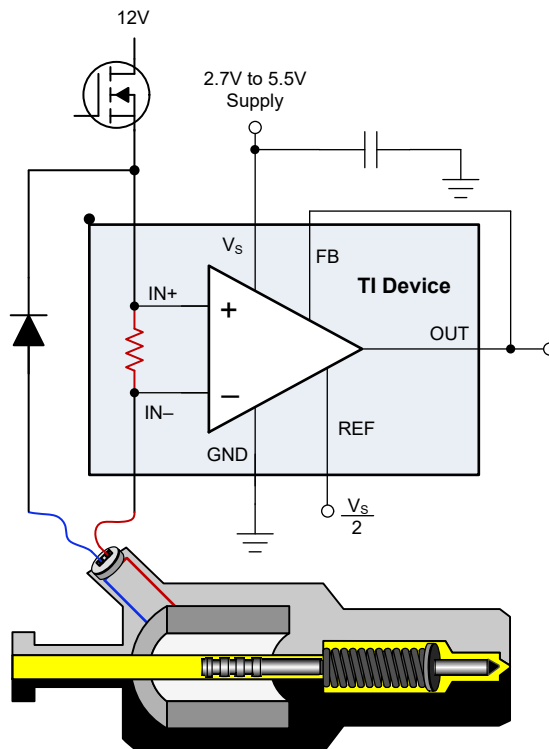

Figure 7-8. Solenoid Drive Application Circuit

7.2.1.1 Design Requirements

For this application, the INA790x measures current in the driver circuit of a 12V, 1A hydraulic valve.

Table 7-5. Design Parameters

DESIGN PARAMETER	EXAMPLE VALUE
Common-mode voltage	12V
Maximum sense current	1A
Power-supply voltage	5V

7.2.1.2 Detailed Design Procedure

To demonstrate the performance of the device, the INA790x, with total gain of 100mV/A (Adjustable Gain =5), is selected for this design and powered from a 5V supply.

Using the information in the [Reference Pin Connections for Bidirectional Current Measurements](#) section, the reference point is set to midscale by splitting the supply at mid point and connecting the REF.

7.2.1.3 Application Curve

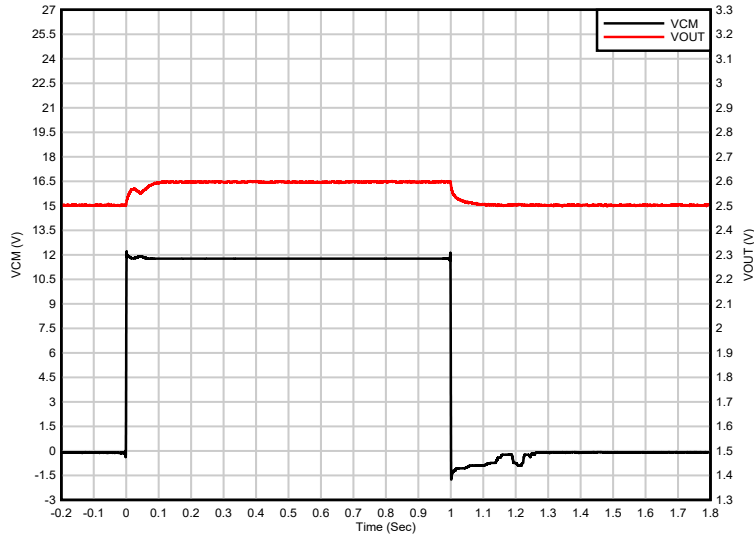

Figure 7-9. Solenoid Drive Current Sense Input and Output Signals

7.2.2 Speaker Enhancements and Diagnostics Using Current Sense Amplifier

CLASS-D audio amplifiers in conjunction with the INA790x provide accurate speaker load current. Speaker load current is used to determine speaker diagnostics, and can further be expanded to measure key speaker parameters, such as speaker coil resistance and speaker real-time ambient temperature.

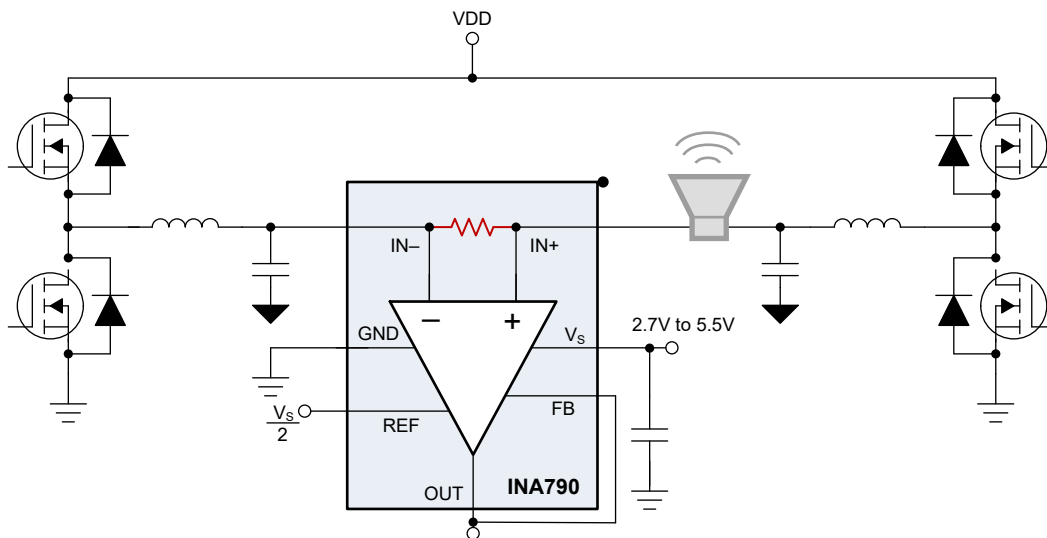

Figure 7-10. Current Sensing in a CLASS-D Subsystem

7.2.2.1 Design Requirements

Table 7-6. Design Parameters

DESIGN PARAMETER	EXAMPLE VALUE
Common-mode voltage	60V
Power-supply voltage	3.3V
Peak current	±15A
Frequency sweep	20Hz to 20kHz

7.2.2.2 Detailed Design Procedure

For this application, the INA790x measures current flowing through the speaker from the CLASS-D amplifier. The integrated shunt of $400\mu\Omega$ with an inductance of only 2nH is an excellent choice for current sensing in speaker applications where low inductance is required. The low-inductive shunt enables accurate current sensing across frequencies over the audio range of 20Hz to 20kHz.

The INA790x is setup to support bidirectional currents with the reference set to mid-supply as shown in [Output Set to Mid-Supply Voltage](#). When the power supply to the INA790x is set at 3.3V and there is no current flowing in the speaker, the output of INA790x is at 1.65V. When operating with a gain of 80mV/A with peak-to-peak current of $\pm 15\text{A}$, the output of the INA790x swings from 0.45V to 2.85V. In this application the output can be directly connected to an ADC input that has a full scale range of 3.3V. The INA790x can measure the impedance of the speaker and accurately measure the resonance frequency and peak impedance at resonance frequency. The INA790x can accurately track changes in the impedance in real-time.

7.2.2.3 Application Curve

Figure 7-11 shows the typical example output response of a speaker with 4Ω impedance measurement from 20Hz to 20kHz.

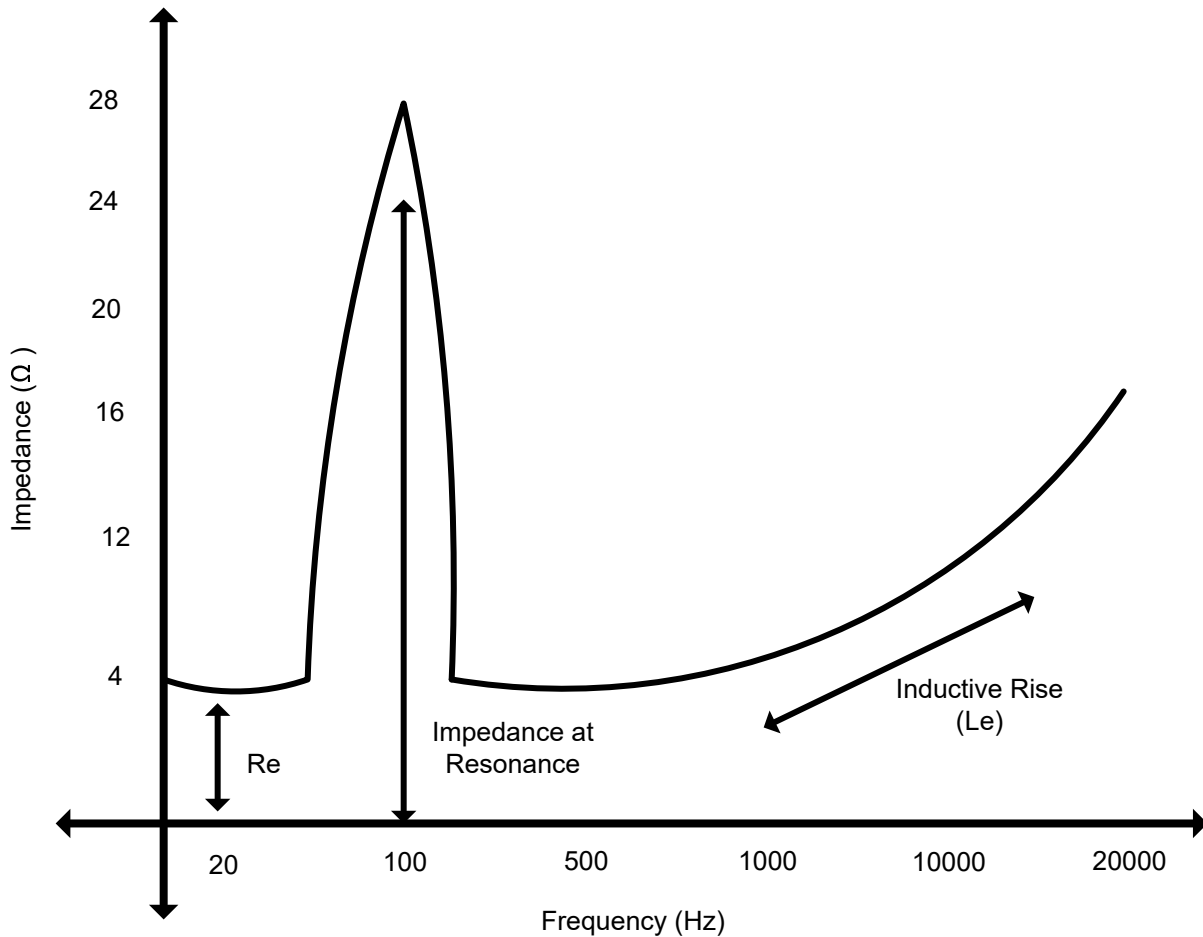

Figure 7-11. Speaker Impedance Measurement

7.3 Power Supply Recommendations

The INA790x makes accurate measurements beyond the connected power-supply voltage (VS) because the inputs (IN+ and IN-) operate anywhere between -4V and +110V, independent of VS. For example, the VS power supply equals 5V and the common-mode voltage of the measured shunt can be as high as 110V. Although the common-mode voltage of the input can be beyond the supply voltage, the output voltage range of the INA790x is constrained to the supply voltage.

Place the power-supply bypass capacitor as close as possible to the supply and ground pins. The recommended value of this bypass capacitor is 0.1μF. Additional decoupling capacitance can be added to compensate for noisy or high-impedance power supplies. If the INA790x output is set to mid-supply, then take extreme care to minimize noise on the power supply.

7.4 Layout

7.4.1 Layout Guidelines

- This device is specified for current handling of up to 50A over the entire -40°C to +125°C temperature range using a 2oz copper pour for the input power plane, as well as no external airflow passing over the device.

- The primary current-handling limitation for this device is how much heat is dissipated inside the package. Efforts to improve heat transfer out of the package and into the surrounding environment improve the ability of the device to handle currents of up to 50A over a wider temperature range.
- Heat transfer improvements primarily involve larger copper power traces and planes with increased copper thickness (2oz.), as well as providing airflow to pass over the device. Thermal vias help spread the current and power dissipated over multiple board layers. The INA790x evaluation module (EVM) features a 2oz copper pour for the planes, and is capable of supporting 50A at temperatures up to 125°C.
- The bypass capacitor must be placed close to device ground and supply pins, but can be moved farther out if needed to avoid cutting thermal planes. The recommended value of this bypass capacitor is 0.1μF. Additional decoupling capacitance can be added to compensate for noisy or high-impedance power supplies.

7.4.2 Layout Example

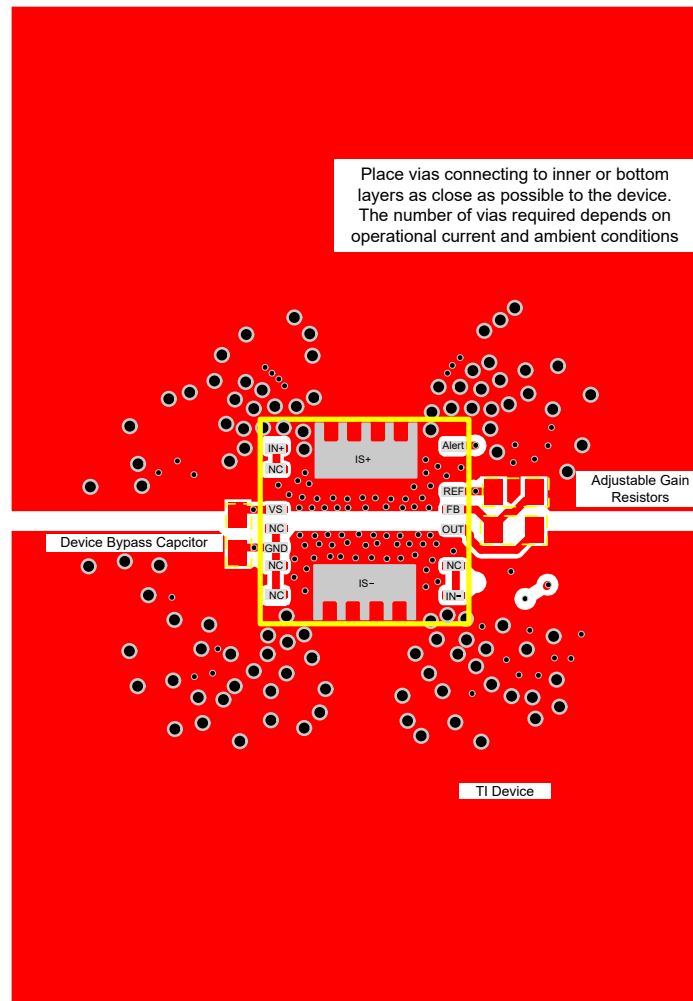

Figure 7-12. INA790x Layout Example

8 Device and Documentation Support

8.1 Documentation Support

8.1.1 Related Documentation

For related documentation, see the following:

- Texas Instruments, [INA79x/EVM](#), EVM User's Guide

8.2 Receiving Notification of Documentation Updates

To receive notification of documentation updates, navigate to the device product folder on [ti.com](https://www.ti.com). Click on *Notifications* to register and receive a weekly digest of any product information that has changed. For change details, review the revision history included in any revised document.

8.3 Support Resources

[TI E2E™ support forums](#) are an engineer's go-to source for fast, verified answers and design help — straight from the experts. Search existing answers or ask your own question to get the quick design help you need.

Linked content is provided "AS IS" by the respective contributors. They do not constitute TI specifications and do not necessarily reflect TI's views; see TI's [Terms of Use](#).

8.4 Trademarks

EZShunt™ and TI E2E™ are trademarks of Texas Instruments.
All trademarks are the property of their respective owners.

8.5 Electrostatic Discharge Caution



This integrated circuit can be damaged by ESD. Texas Instruments recommends that all integrated circuits be handled with appropriate precautions. Failure to observe proper handling and installation procedures can cause damage.

ESD damage can range from subtle performance degradation to complete device failure. Precision integrated circuits may be more susceptible to damage because very small parametric changes could cause the device not to meet its published specifications.

8.6 Glossary

[TI Glossary](#) This glossary lists and explains terms, acronyms, and definitions.

9 Revision History

Changes from Revision * (May 2024) to Revision A (December 2024)	Page
• Updated the number formatting for tables, figures, and cross-references throughout the document.....	1

PACKAGING INFORMATION

Orderable Device	Status (1)	Package Type	Package Drawing	Pins	Package Qty	Eco Plan (2)	Lead finish/ Ball material (6)	MSL Peak Temp (3)	Op Temp (°C)	Device Marking (4/5)	Samples
INA790BIDEKR	ACTIVE	VQFN	DEK	15	4000	RoHS & Green	NIPDAU	Level-1-260C-UNLIM	-40 to 125	INA 790B	Samples
PINA790BIDEKR	ACTIVE	VQFN	DEK	15	4000	TBD	Call TI	Call TI	-40 to 125		Samples

(1) The marketing status values are defined as follows:

ACTIVE: Product device recommended for new designs.

LIFEBUY: TI has announced that the device will be discontinued, and a lifetime-buy period is in effect.

NRND: Not recommended for new designs. Device is in production to support existing customers, but TI does not recommend using this part in a new design.

PREVIEW: Device has been announced but is not in production. Samples may or may not be available.

OBSELETE: TI has discontinued the production of the device.

(2) **RoHS:** TI defines "RoHS" to mean semiconductor products that are compliant with the current EU RoHS requirements for all 10 RoHS substances, including the requirement that RoHS substance do not exceed 0.1% by weight in homogeneous materials. Where designed to be soldered at high temperatures, "RoHS" products are suitable for use in specified lead-free processes. TI may reference these types of products as "Pb-Free".

RoHS Exempt: TI defines "RoHS Exempt" to mean products that contain lead but are compliant with EU RoHS pursuant to a specific EU RoHS exemption.

Green: TI defines "Green" to mean the content of Chlorine (Cl) and Bromine (Br) based flame retardants meet JS709B low halogen requirements of <=1000ppm threshold. Antimony trioxide based flame retardants must also meet the <=1000ppm threshold requirement.

(3) MSL, Peak Temp. - The Moisture Sensitivity Level rating according to the JEDEC industry standard classifications, and peak solder temperature.

(4) There may be additional marking, which relates to the logo, the lot trace code information, or the environmental category on the device.

(5) Multiple Device Markings will be inside parentheses. Only one Device Marking contained in parentheses and separated by a "-" will appear on a device. If a line is indented then it is a continuation of the previous line and the two combined represent the entire Device Marking for that device.

(6) Lead finish/Ball material - Orderable Devices may have multiple material finish options. Finish options are separated by a vertical ruled line. Lead finish/Ball material values may wrap to two lines if the finish value exceeds the maximum column width.

Important Information and Disclaimer:The information provided on this page represents TI's knowledge and belief as of the date that it is provided. TI bases its knowledge and belief on information provided by third parties, and makes no representation or warranty as to the accuracy of such information. Efforts are underway to better integrate information from third parties. TI has taken and continues to take reasonable steps to provide representative and accurate information but may not have conducted destructive testing or chemical analysis on incoming materials and chemicals. TI and TI suppliers consider certain information to be proprietary, and thus CAS numbers and other limited information may not be available for release.

In no event shall TI's liability arising out of such information exceed the total purchase price of the TI part(s) at issue in this document sold by TI to Customer on an annual basis.

TAPE AND REEL INFORMATION

QUADRANT ASSIGNMENTS FOR PIN 1 ORIENTATION IN TAPE

*All dimensions are nominal

Device	Package Type	Package Drawing	Pins	SPQ	Reel Diameter (mm)	Reel Width W1 (mm)	A0 (mm)	B0 (mm)	K0 (mm)	P1 (mm)	W (mm)	Pin1 Quadrant
INA790BIDEKR	VQFN	DEK	15	4000	330.0	16.4	6.3	6.3	1.1	12.0	16.0	Q2

TAPE AND REEL BOX DIMENSIONS

*All dimensions are nominal

Device	Package Type	Package Drawing	Pins	SPQ	Length (mm)	Width (mm)	Height (mm)
INA790BIDEKR	VQFN	DEK	15	4000	360.0	360.0	36.0

IMPORTANT NOTICE AND DISCLAIMER

TI PROVIDES TECHNICAL AND RELIABILITY DATA (INCLUDING DATA SHEETS), DESIGN RESOURCES (INCLUDING REFERENCE DESIGNS), APPLICATION OR OTHER DESIGN ADVICE, WEB TOOLS, SAFETY INFORMATION, AND OTHER RESOURCES "AS IS" AND WITH ALL FAULTS, AND DISCLAIMS ALL WARRANTIES, EXPRESS AND IMPLIED, INCLUDING WITHOUT LIMITATION ANY IMPLIED WARRANTIES OF MERCHANTABILITY, FITNESS FOR A PARTICULAR PURPOSE OR NON-INFRINGEMENT OF THIRD PARTY INTELLECTUAL PROPERTY RIGHTS.

These resources are intended for skilled developers designing with TI products. You are solely responsible for (1) selecting the appropriate TI products for your application, (2) designing, validating and testing your application, and (3) ensuring your application meets applicable standards, and any other safety, security, regulatory or other requirements.

These resources are subject to change without notice. TI grants you permission to use these resources only for development of an application that uses the TI products described in the resource. Other reproduction and display of these resources is prohibited. No license is granted to any other TI intellectual property right or to any third party intellectual property right. TI disclaims responsibility for, and you will fully indemnify TI and its representatives against, any claims, damages, costs, losses, and liabilities arising out of your use of these resources.

TI's products are provided subject to [TI's Terms of Sale](#) or other applicable terms available either on [ti.com](https://www.ti.com) or provided in conjunction with such TI products. TI's provision of these resources does not expand or otherwise alter TI's applicable warranties or warranty disclaimers for TI products.

TI objects to and rejects any additional or different terms you may have proposed.

Mailing Address: Texas Instruments, Post Office Box 655303, Dallas, Texas 75265

Copyright © 2025, Texas Instruments Incorporated