

LM5008A 95-V, 350-mA, Constant On-Time DC/DC Buck Switching Regulator

1 Features

- Operating Input Voltage Range: 6 V to 95 V
- Integrated 100-V N-Channel Buck Switch
- Internal Start-Up Regulator
- No Loop Compensation Required
- Ultra-Fast Transient Response
- On-Time Varies Inversely With Input Voltage
- Operating Frequency Remains Constant With Varying Line Voltage and Load Current
- Adjustable Output Voltage From 2.5 V
- Highly Efficient Operation
- Precision Internal Reference
- Low Bias Current
- Intelligent Current Limit
- Thermal Shutdown
- 8-Pin VSSOP and 8-Pin WSON Packages
- Create a Custom Design Using the LM5008A With the [WEBENCH® Power Designer](#)

2 Applications

- Non-Isolated Telecommunication Buck Regulators
- Secondary High-Voltage Post Regulators
- 48-V Automotive Systems

3 Description

The LM5008A DC/DC converter is a functional variant of the LM5008 COT Buck Switching Regulator. The functional differences of the LM5008A are: the minimum input operating voltage is 6 V, the on-time equation is slightly different, and the requirement for a minimum load current is removed.

The LM5008A 350-mA step-down switching regulator features all of the functions required to implement a low-cost and efficient buck regulator. This high-voltage converter has an integrated 100-V N-channel buck switch and operates over an input voltage range of 6 V to 95 V. The device is easy to implement and is provided in 8-pin VSSOP and the thermally enhanced 8-pin WSON packages. The converter uses PWM control scheme with an on-time inversely proportional to V_{IN} . This feature allows the operating frequency to remain relatively constant. The control scheme requires no loop compensation. An intelligent current limit is implemented with forced off-time, which is inversely proportional to V_{OUT} . This scheme ensures short-circuit control while providing minimum foldback. Other features include: thermal shutdown, V_{CC} undervoltage lockout, gate drive undervoltage lockout, maximum duty cycle limiter, and a pre-charge switch.

Device Information⁽¹⁾

PART NUMBER	PACKAGE	BODY SIZE (NOM)
LM5008A	VSSOP (8)	3.00 mm × 3.00 mm
	WSON (8)	4.00 mm × 4.00 mm

(1) For all available packages, see the orderable addendum at the end of the data sheet.

Typical Application, Basic Step-Down Regulator

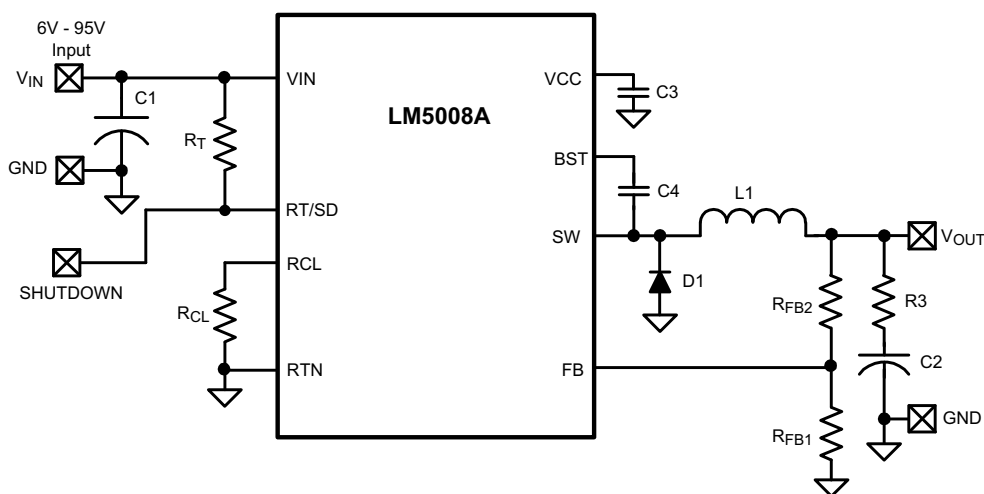

Copyright © 2016, Texas Instruments Incorporated



Table of Contents

1 Features	1	7.4 Device Functional Modes.....	12
2 Applications	1	8 Application and Implementation	13
3 Description	1	8.1 Application Information.....	13
4 Revision History	2	8.2 Typical Application	13
5 Pin Configuration and Functions	3	9 Power Supply Recommendations	18
6 Specifications	4	10 Layout	19
6.1 Absolute Maximum Ratings	4	10.1 Layout Guidelines	19
6.2 ESD Ratings	4	10.2 Layout Example	19
6.3 Recommended Operating Conditions.....	4	11 Device and Documentation Support	20
6.4 Thermal Information	4	11.1 Device Support	20
6.5 Electrical Characteristics.....	5	11.2 Documentation Support	20
6.6 Switching Characteristics	6	11.3 Receiving Notification of Documentation Updates	21
6.7 Typical Characteristics	7	11.4 Community Resources.....	21
7 Detailed Description	8	11.5 Trademarks	21
7.1 Overview	8	11.6 Electrostatic Discharge Caution.....	21
7.2 Functional Block Diagram	8	11.7 Glossary	21
7.3 Feature Description.....	8	12 Mechanical, Packaging, and Orderable Information	21

4 Revision History

NOTE: Page numbers for previous revisions may differ from page numbers in the current version.

Changes from Revision G (December 2016) to Revision H	Page
• Added links for WEBENCH	1
• Changed VSSOP-8 body size to 3 mm x 3 mm in <i>Device Information</i>	1

Changes from Revision F (March 2013) to Revision G	Page
• Added <i>ESD Ratings</i> table, <i>Feature Description</i> section, <i>Device Functional Modes</i> , <i>Application and Implementation</i> section, <i>Power Supply Recommendations</i> section, <i>Layout</i> section, <i>Device and Documentation Support</i> section, and <i>Mechanical, Packaging, and Orderable Information</i> section	1
• Deleted Lead temperature (260°C maximum).....	4
• Changed R _{θJA} value From: 200°C/W To: 139.7°C/W (VSSOP) and From: 40°C/W To: 42°C/W (WSON).....	4

Changes from Revision E (March 2013) to Revision F	Page
• Changed layout of National Data Sheet to TI format	17

5 Pin Configuration and Functions

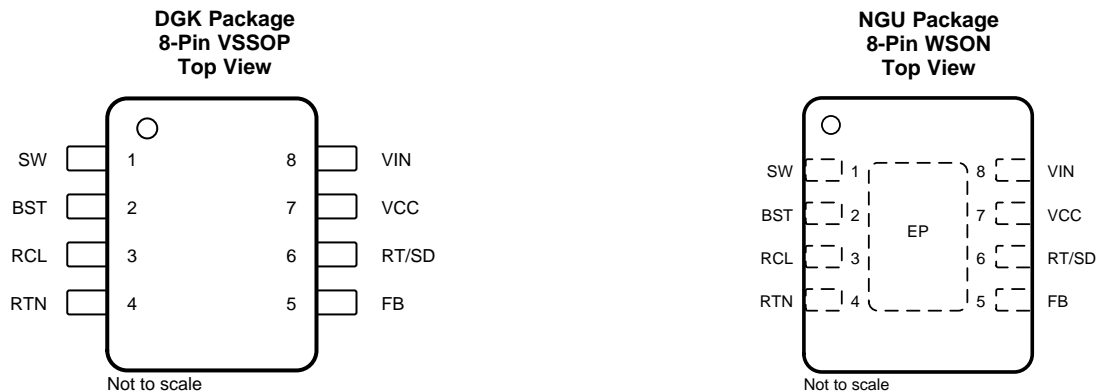

Pin Functions

PIN		TYPE	DESCRIPTION
NO.	NAME		
1	SW	P	Switching node: power switching node. Connect to the output inductor, re-circulating diode, and bootstrap capacitor.
2	BST	I	Boost pin (bootstrap capacitor input): an external capacitor is required between the BST and the SW pins. A 0.01- μ F ceramic capacitor is recommended. An internal diode charges the capacitor from V_{CC} during each off-time.
3	RCL	I	Current limit off-time set pin: a resistor between this pin and RTN sets the off-time when current limit is detected. The off-time is preset to 35 μ s if $FB = 0$ V.
4	RTN	G	Ground pin: ground for the entire circuit.
5	FB	I	Feedback input from regulated output: this pin is connected to the inverting input of the internal regulation comparator. The regulation threshold is 2.5 V.
6	RT/SD	I	On-time set pin: a resistor between this pin and V_{IN} sets the switch on time as a function of V_{IN} . The minimum recommended on time is 400 ns at the maximum input voltage. This pin can be used for remote shutdown.
7	VCC	P	Output from the internal high voltage series pass regulator: this regulated voltage provides gate drive power for the internal buck switch. An internal diode is provided between this pin and the BST pin. A local 0.47- μ F decoupling capacitor is required. The series pass regulator is current limited to 9 mA.
8	VIN	P	Input voltage: input operating range from 6 V to 95 V.
—	EP	G	Exposed pad: the exposed pad has no electrical contact. Connect to system ground plane for reduced thermal resistance. (WSON package only)

6 Specifications

6.1 Absolute Maximum Ratings

over operating free-air temperature range (unless otherwise noted)⁽¹⁾

	MIN	MAX	UNIT
V _{IN} to GND	−0.3	100	V
BST to GND	−0.3	114	V
SW to GND (steady-state)		−1	V
BST to V _{CC}		100	V
BST to SW		14	V
V _{CC} to GND		14	V
All other inputs to GND	−0.3	7	V
Storage temperature, T _{stg}	−55	150	°C

- (1) Stresses beyond those listed under *Absolute Maximum Ratings* may cause permanent damage to the device. These are stress ratings only, which do not imply functional operation of the device at these or any other conditions beyond those indicated under *Recommended Operating Conditions*. Exposure to absolute-maximum-rated conditions for extended periods may affect device reliability.

6.2 ESD Ratings

		VALUE	UNIT
V _(ESD) Electrostatic discharge	Human-body model (HBM), per ANSI/ESDA/JEDEC JS-001 ⁽¹⁾	±2000	V
	Charged-device model (CDM), per JEDEC specification JESD22-C101 ⁽²⁾	±750	

- (1) JEDEC document JEP155 states that 500-V HBM allows safe manufacturing with a standard ESD control process.
 (2) JEDEC document JEP157 states that 250-V CDM allows safe manufacturing with a standard ESD control process.

6.3 Recommended Operating Conditions

over operating free-air temperature range (unless otherwise noted)

	MIN	MAX	UNIT
V _{IN}	6	95	V
Operating junction temperature	−40	125	°C

6.4 Thermal Information

THERMAL METRIC ⁽¹⁾	LM5008A		UNIT
	DGK (VSSOP)	NGU (WSON)	
	8 PINS	8 PINS	
R _{θJA} Junction-to-ambient thermal resistance	139.7	42	°C/W
R _{θJC(top)} Junction-to-case (top) thermal resistance	51.2	27.6	°C/W
R _{θJB} Junction-to-board thermal resistance	70.5	18.5	°C/W
ψ _{JT} Junction-to-top characterization parameter	3.4	0.3	°C/W
ψ _{JB} Junction-to-board characterization parameter	69.5	18.5	°C/W
R _{θJC(bot)} Junction-to-case (bottom) thermal resistance	—	4.3	°C/W

- (1) For more information about traditional and new thermal metrics, see the [Semiconductor and IC Package Thermal Metrics](#) application report.

6.5 Electrical Characteristics

 $T_J = 25^\circ\text{C}$ and $V_{IN} = 48\text{ V}$ (unless otherwise noted)⁽¹⁾

PARAMETER		TEST CONDITIONS	MIN	TYP	MAX	UNIT
VCC SUPPLY						
V_{CC} Reg	V_{CC} regulator output	$V_{IN} = 48\text{ V}$	$T_J = 25^\circ\text{C}$	7		V
			$T_J = -40^\circ\text{C}$ to 125°C	6.6	7.4	
	$V_{IN} - V_{CC}$	$6\text{ V} < V_{IN} < 8.5\text{ V}$		100		mV
	V_{CC} bypass threshold	V_{IN} increasing		8.5		V
	V_{CC} bypass hysteresis			300		mV
V_{CC} output impedance		$V_{IN} = 6\text{ V}$		100		Ω
		$V_{IN} = 10\text{ V}$		8.8		Ω
		$V_{IN} = 48\text{ V}$		0.8		Ω
	V_{CC} current limit	$V_{IN} = 48\text{ V}$		9.2		mA
	V_{CC} UVLO	V_{CC} increasing		5.3		V
	V_{CC} UVLO hysteresis			190		mV
	V_{CC} UVLO filter delay			3		μs
I_{IN} operating current	FB = 3 V, $V_{IN} = 48\text{ V}$		$T_J = 25^\circ\text{C}$	550		μA
			$T_J = -40^\circ\text{C}$ to 125°C		750	
I_{IN} shutdown current	RT/SD = 0 V		$T_J = 25^\circ\text{C}$	110		μA
			$T_J = -40^\circ\text{C}$ to 125°C		176	
CURRENT LIMIT						
Current limit threshold			$T_J = 25^\circ\text{C}$	0.51		A
			$T_J = -40^\circ\text{C}$ to 125°C	0.41	0.61	
Current limit response time		I_{switch} overdrive = 0.1 A, time to switch off		350		ns
$T_{\text{OFF-1}}$	Off-time generator	FB = 0 V, $R_{CL} = 100\text{ k}\Omega$		35		μs
$T_{\text{OFF-2}}$	Off-time generator	FB = 2.3 V, $R_{CL} = 100\text{ k}\Omega$		2.56		μs
ON-TIME GENERATOR						
$T_{\text{ON-1}}$		$V_{IN} = 10\text{ V}$, $R_{\text{ON}} = 200\text{ k}\Omega$	$T_J = 25^\circ\text{C}$	2.77		μs
			$T_J = -40^\circ\text{C}$ to 125°C	2.15	3.5	
$T_{\text{ON-2}}$		$V_{IN} = 95\text{ V}$, $R_{\text{ON}} = 200\text{ k}\Omega$	$T_J = 25^\circ\text{C}$	300		ns
			$T_J = -40^\circ\text{C}$ to 125°C	200	420	
Remote shutdown threshold	Rising		$T_J = 25^\circ\text{C}$	0.7		V
			$T_J = -40^\circ\text{C}$ to 125°C	0.4	1.05	
Remote shutdown hysteresis				35		mV
MINIMUM OFF-TIME						
Minimum off-timer		$V_{FB} = 0\text{ V}$		300		ns
REGULATION AND OV COMPARATORS						
FB reference threshold	Internal reference, trip point for switch ON		$T_J = 25^\circ\text{C}$	2.5		V
			$T_J = -40^\circ\text{C}$ to 125°C	2.445	2.55	
FB overvoltage threshold	Trip point for switch OFF			2.875		V
FB bias current				100		nA
THERMAL SHUTDOWN						
T_{sd}	Thermal shutdown temperature			165		$^\circ\text{C}$
	Thermal shutdown hysteresis			25		$^\circ\text{C}$

(1) All electrical characteristics having room temperature limits are tested during production with $T_A = T_J = 25^\circ\text{C}$. All hot and cold limits are specified by correlating the electrical characteristics to process and temperature variations and applying statistical process control.

6.6 Switching Characteristics

over operating free-air temperature range (unless otherwise noted)

PARAMETER	TEST CONDITIONS	MIN	TYP	MAX	UNIT
Buck switch $R_{DS(on)}$	$I_{TEST} = 200 \text{ mA}$	$T_J = 25^\circ\text{C}$	1.25		Ω
		$T_J = -40^\circ\text{C to } 125^\circ\text{C}$		2.57	
Gate drive UVLO	$V_{BST} - V_{SW}$ rising	$T_J = 25^\circ\text{C}$	3.8		V
		$T_J = -40^\circ\text{C to } 125^\circ\text{C}$	2.8	4.8	
Gate drive UVLO hysteresis			490		mV
Pre-charge switch voltage	At 1 mA		0.8		V
Pre-charge switch on-time			150		ns

6.7 Typical Characteristics

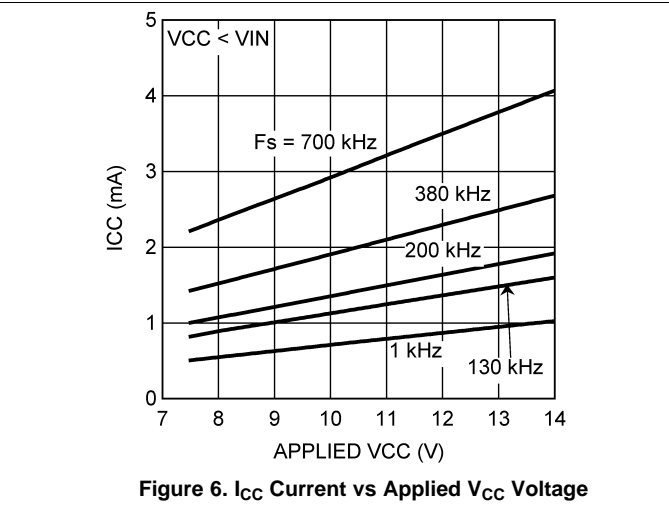
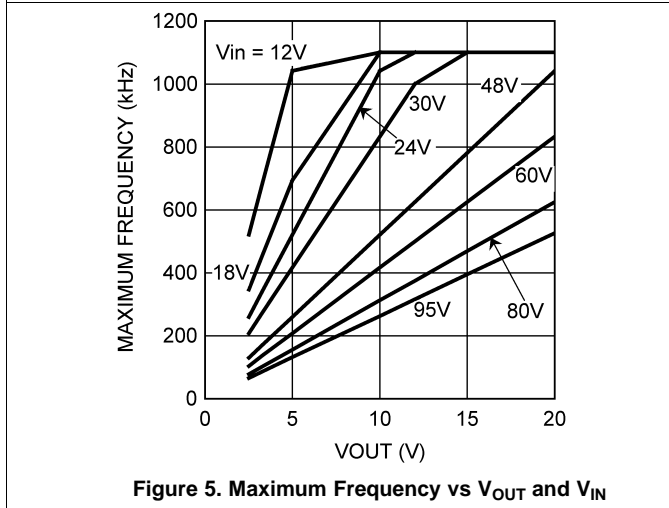
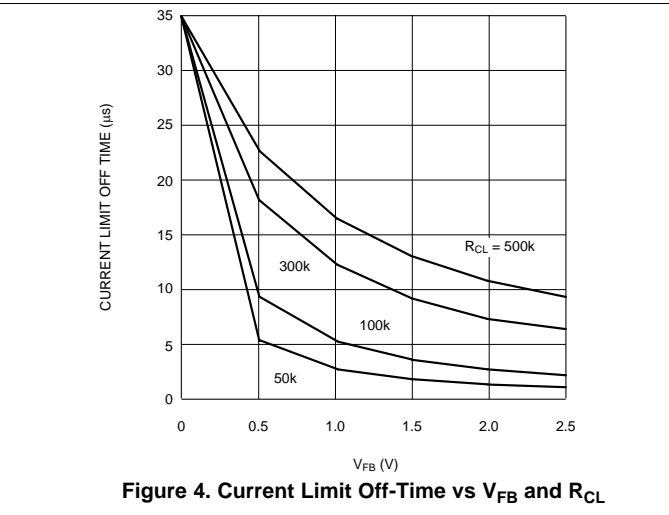
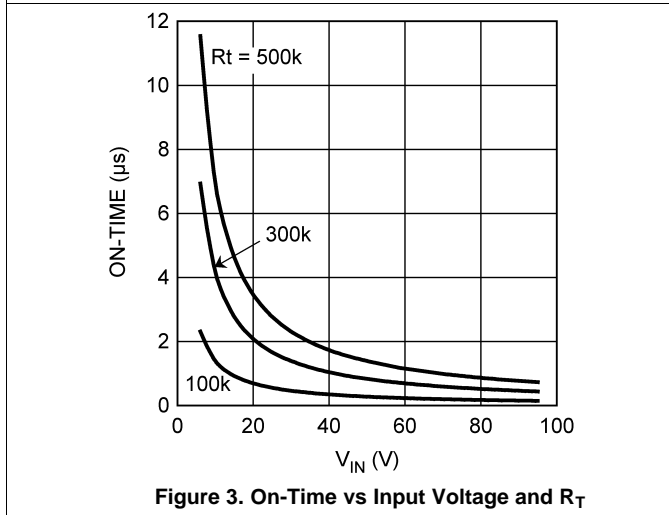
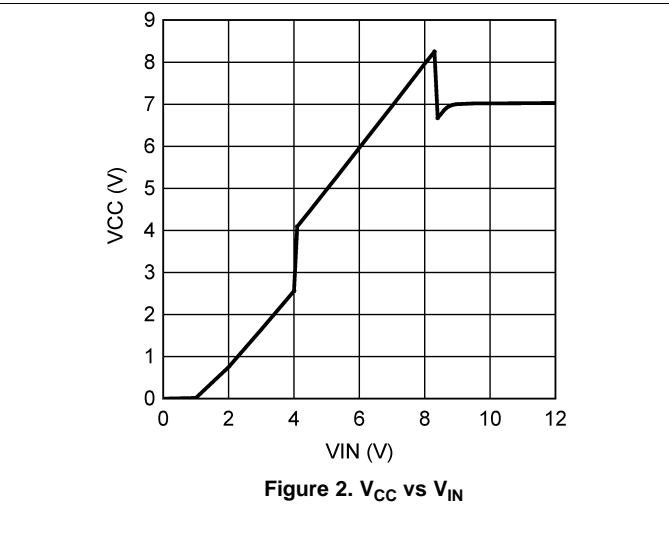
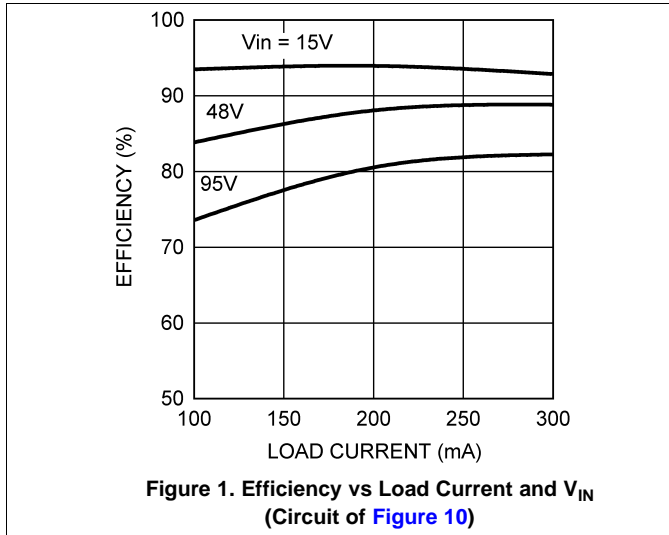

7 Detailed Description

7.1 Overview

The LM5008A regulator is an easy-to-use buck DC-DC converter that operates from 6-V to 95-V supply voltage. The device is intended for step-down conversions from 12-V, 24-V, and 48-V unregulated, semi-regulated and fully-regulated supply rails. With integrated buck power MOSFET, the LM5008A delivers up to 350-mA DC load current with exceptional efficiency and low input quiescent current in a very small solution size.

Designed for simple implementation, a nearly fixed-frequency, constant on-time (COT) operation with discontinuous conduction mode (DCM) at light loads is ideal for low-noise, high current, fast transient load requirements. Control loop compensation is not required reducing design time and external component count.

The LM5008A incorporates other features for comprehensive system requirements, including VCC undervoltage lockout (UVLO), gate drive undervoltage lockout, maximum duty cycle limiter, intelligent current limit off-timer, a pre-charge switch, and thermal shutdown with automatic recovery. These features enable a flexible and easy-to-use platform for a wide range of applications. The pin arrangement is designed for simple and optimized PCB layout, requiring only a few external components.

7.2 Functional Block Diagram

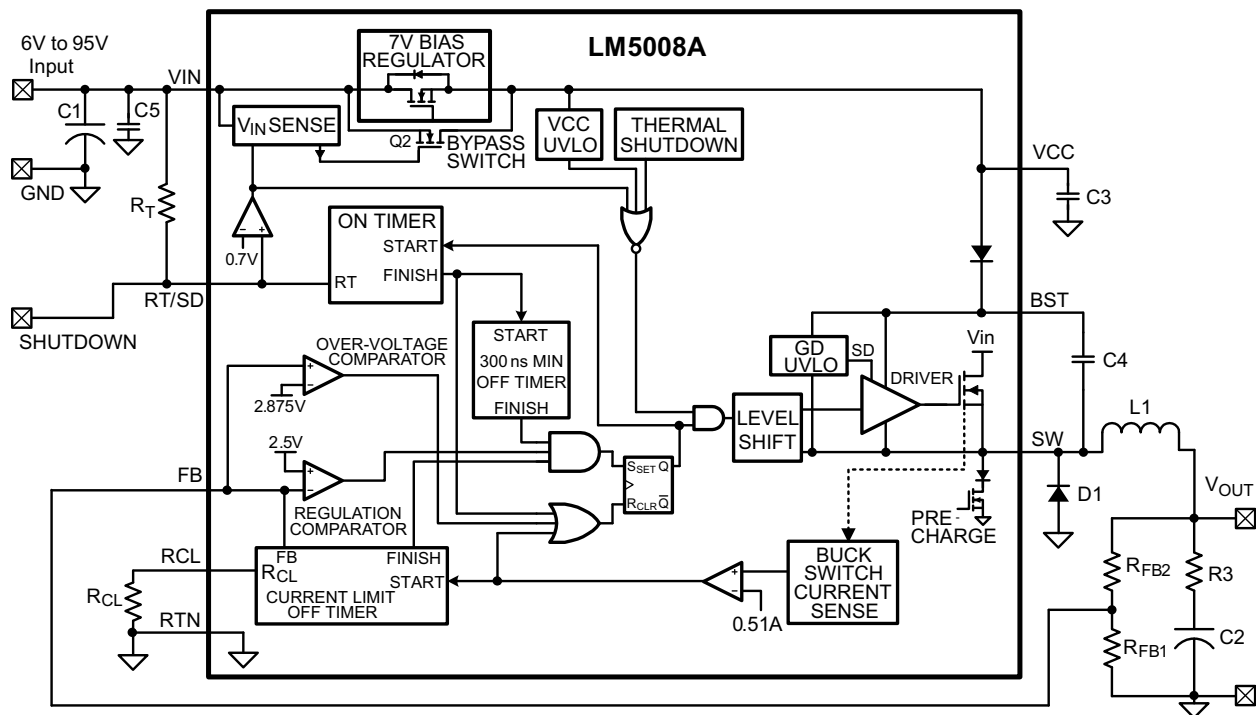

Copyright © 2016, Texas Instruments Incorporated

7.3 Feature Description

7.3.1 Control Circuit Overview

The LM5008A is a buck DC-DC regulator that uses a control scheme in which the on-time varies inversely with line voltage (V_{IN}). Control is based on a comparator and the on-time one-shot, with the output voltage feedback (FB) compared to an internal reference (2.5 V). If the FB level is below the reference the buck switch is turned on for a fixed time determined by the line voltage and a programming resistor (R_T). Following the ON period, the switch remains off for at least the minimum off-timer period of 300 ns. If FB is still below the reference at that time, the switch turns on again for another on-time period. This continues until regulation is achieved.

Feature Description (continued)

The LM5008A operates in discontinuous conduction mode at light load currents, and continuous conduction mode at heavy load current. In discontinuous conduction mode, current through the output inductor starts at zero and ramps up to a peak during the on-time, then ramps back to zero before the end of the off-time. The next on-time period starts when the voltage at FB falls below the internal reference; until then, the inductor current remains zero. In this mode, the operating frequency is lower than in continuous conduction mode and varies with load current. Therefore, at light loads, the conversion efficiency is maintained because the switching losses reduce with the reduction in load and frequency. The discontinuous operating frequency can be calculated with [Equation 1](#).

$$F = \frac{V_{OUT}^2 \times L \times 1.04 \times 10^{20}}{R_L \times (R_T)^2}$$

where

- R_L = the load resistance (1)

In continuous conduction mode, current flows continuously through the inductor and never ramps down to zero. In this mode the operating frequency is greater than the discontinuous mode frequency and remains relatively constant with load and line variations. The approximate continuous mode operating frequency can be calculated with [Equation 2](#).

$$F = \frac{V_{OUT}}{1.385 \times 10^{-10} \times R_T}$$
(2)

The output voltage (V_{OUT}) is programmed by two external resistors as shown in the [Functional Block Diagram](#). The regulation point can be calculated with [Equation 3](#).

$$V_{OUT} = 2.5 \times (R_{FB1} + R_{FB2}) / R_{FB1}$$
(3)

The LM5008A regulates the output voltage based on ripple voltage at the feedback input, requiring a minimum amount of ESR for the output capacitor C2. A minimum of 25 mV to 50 mV of ripple voltage at the feedback pin (FB) is required for the LM5008A. In cases where the capacitor ESR is too small, additional series resistance may be required (R3 in the [Functional Block Diagram](#)).

For applications where lower output voltage ripple is required, the output can be taken directly from a low-ESR output capacitor as shown in [Figure 7](#). However, R3 slightly degrades the load regulation.

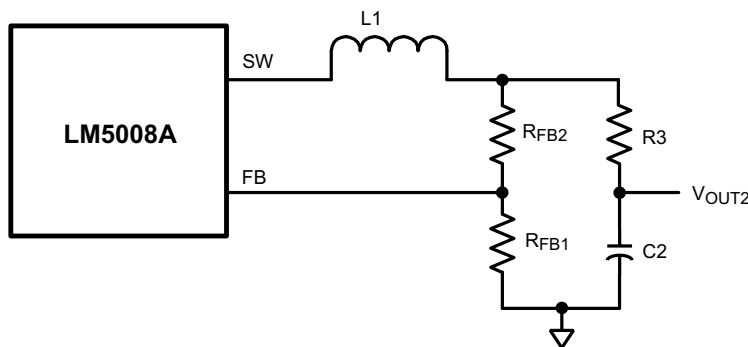

Copyright © 2016, Texas Instruments Incorporated

Figure 7. Low-Ripple Output Configuration

7.3.2 Start-Up Regulator (V_{CC})

The high voltage bias regulator is integrated within the LM5008A. The input pin (V_{IN}) can be connected directly to line voltages between 6 V and 95 V, with transient capability to 100 V. Referring to the [Functional Block Diagram](#) and [Figure 2](#), when V_{IN} is between 6 V and the bypass threshold (nominally 8.5 V), the bypass switch (Q2) is on, and V_{CC} tracks V_{IN} within 100 mV to 150 mV. The bypass switch on-resistance is approximately 100 Ω , with inherent current limiting at approximately 100 mA. When V_{IN} is above the bypass threshold Q2 is turned off, and V_{CC} is regulated at 7 V. The V_{CC} regulator output current is limited at approximately 9.2 mA. When the LM5008A is shut down using the RT/SD pin, the V_{CC} bypass switch is shut off regardless of the voltage at V_{IN} .

Feature Description (continued)

When V_{IN} exceeds the bypass threshold, the time required for Q2 to shut off is approximately 2 μ s to 3 μ s. The capacitor at VCC (C3) must be a minimum of 0.47 μ F to prevent the voltage at V_{CC} from rising above its absolute maximum rating in response to a step input applied at V_{IN} . C3 must be placed as close as possible to the VCC and RTN pins. In applications with a relatively high input voltage, power dissipation in the bias regulator is a concern. An auxiliary voltage of between 7.5 V and 14 V can be diode connected to the VCC pin to shut off the V_{CC} regulator, thereby reducing internal power dissipation. The current required into the VCC pin is shown in Figure 6. Internally a diode connects VCC to V_{IN} requiring that the auxiliary voltage be less than V_{IN} .

The turnon sequence is shown in Figure 8. During the initial delay (t_1), VCC ramps up at a rate determined by its current limit and C3 while internal circuitry stabilizes. When V_{CC} reaches the upper threshold of its undervoltage lockout (UVLO, typically 5.3 V), the buck switch is enabled. The inductor current increases to the current limit threshold (I_{LIM}), and during t_2 the V_{OUT} increases as the output capacitor charges up. When V_{OUT} reaches the intended voltage the average inductor current decreases (t_3) to the nominal load current (I_O).

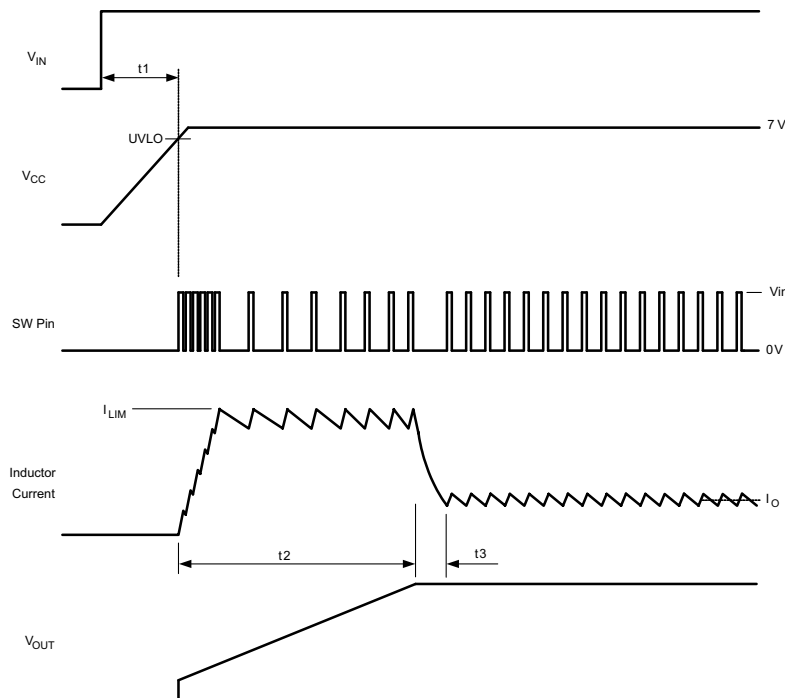

Figure 8. Start-Up Sequence

7.3.3 Regulation Comparator

The feedback voltage at FB is compared to an internal 2.5-V reference. In normal operation (the output voltage is regulated), an on-time period is initiated when the voltage at FB falls below 2.5 V. The buck switch stays on for the on-time, causing the FB voltage to rise above 2.5 V. After the on-time period, the buck switch stays off until the FB voltage again falls below 2.5 V. During start-up, the FB voltage is below 2.5 V at the end of each on-time, resulting in the minimum off-time of 300 ns. Bias current at the FB pin is nominally 100 nA.

7.3.4 Overvoltage Comparator

The feedback voltage at FB is compared to an internal 2.875-V reference. If the voltage at FB rises above 2.875 V, the on-time pulse is immediately terminated. This condition can occur if the input voltage or the output load change suddenly. The buck switch does not turn on again until the voltage at FB falls below 2.5 V.

7.3.5 On-Time Generator and Shutdown

The on-time for the LM5008A is determined by the R_T resistor and is inversely proportional to the input voltage (V_{IN}), resulting in a nearly constant frequency as V_{IN} is varied over its range. The on-time equation for the LM5008A is Equation 4.

Feature Description (continued)

$$T_{ON} = 1.385 \times 10^{-10} \times R_T / V_{IN} \quad (4)$$

R_T must be selected for a minimum on-time (at maximum V_{IN}) greater than 400 ns, for proper current limit operation. This requirement limits the maximum frequency for each application, depending on V_{IN} and V_{OUT} .

The LM5008A can be remotely disabled by taking the R_T/SD pin to ground. See Figure 9. The voltage at the R_T/SD pin is between 1.5 V and 3 V, depending on V_{IN} and the value of the R_T resistor.

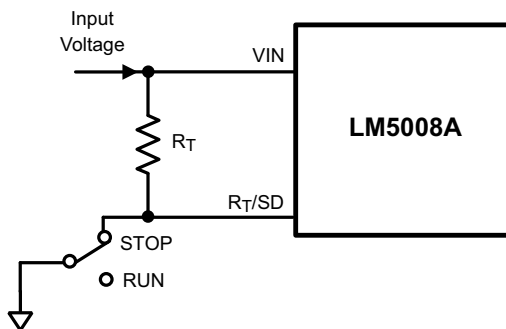

Copyright © 2016, Texas Instruments Incorporated

Figure 9. Shutdown Implementation

7.3.6 Current Limit

The LM5008A contains an intelligent current limit OFF timer. If the current in the Buck switch exceeds 0.51 A the present cycle is immediately terminated and a non-resettable OFF timer is initiated. The length of off-time is controlled by an external resistor (R_{CL}) and the FB voltage (see Figure 4). When $FB = 0$ V, a maximum off-time is required, and the time is preset to 35 μ s. This condition occurs when the output is shorted and during the initial part of start-up. This amount of time ensures safe short-circuit operation up to the maximum input voltage of 95 V. In cases of overload where the FB voltage is above zero volts (not a short circuit), the current limit off-time is less than 35 μ s. Reducing the off-time during less severe overloads reduces the amount of foldback, recovery time, and the start-up time. The off-time is calculated from Equation 5.

$$T_{OFF} = \frac{10^{-5}}{0.285 + \left(\frac{V_{FB}}{6.35 \times 10^{-6} \times R_{CL}} \right)} \quad (5)$$

The current limit-sensing circuit is blanked for the first 50 ns to 70 ns of each on-time, so it is not falsely tripped by the current surge which occurs at turnon. The current surge is required by the re-circulating diode (D1) for its turnoff recovery.

7.3.7 N-Channel Buck Switch and Driver

The LM5008A integrates an N-Channel Buck switch and associated floating high voltage gate driver. The gate driver circuit works in conjunction with an external bootstrap capacitor and an internal high voltage diode. A 0.01- μ F ceramic capacitor (C4) connected between the BST pin and SW pin provides the voltage to the driver during the on-time.

During each off-time, the SW pin is at approximately 0 V and the bootstrap capacitor charges from V_{CC} through the internal diode. The minimum off-timer, set to 300 ns, ensures a minimum time each cycle to recharge the bootstrap capacitor.

The internal pre-charge switch at the SW pin is turned on for ≈ 150 ns during the minimum off-time period, ensuring sufficient voltage exists across the bootstrap capacitor for the on-time. This feature helps prevent operating problems which can occur during very light-load conditions, involving a long off-time, during which the voltage across the bootstrap capacitor could otherwise reduce below the Gate Drive UVLO threshold. The pre-charge switch also helps prevent start-up problems which can occur if the output voltage is pre-charged prior to turnon. After current limit detection, the pre-charge switch is turned on for the entire duration of the forced off-time.

Feature Description (continued)

7.3.8 Thermal Protection

The LM5008A must be operated so the junction temperature does not exceed 125°C during normal operation. An internal Thermal Shutdown circuit is provided to shutdown the LM5008A in the event of a higher than normal junction temperature. When activated, typically at 165°C, the controller is forced into a low-power reset state by disabling the buck switch. This feature prevents catastrophic failures from accidental device overheating. When the junction temperature reduces below 140°C (typical hysteresis = 25°C), normal operation is resumed.

7.4 Device Functional Modes

7.4.1 Shutdown Mode

The RT/SD pin provides ON and OFF control for the LM5008A. When V_{SD} is below approximately 0.7 V, the device is in shutdown mode. Both the internal LDO and the switching regulator are off. The quiescent current in shutdown mode drops to 110 μ A (typical) at $V_{IN} = 48$ V. The LM5008A also employs V_{CC} bias rail undervoltage protection. If the V_{CC} bias supply voltage is below its UV threshold, the regulator remains off.

7.4.2 Active Mode

LM5008A is in active mode when the internal bias rail, V_{CC} , is above its UV threshold. Depending on the load current, the device operates in either DCM or CCM mode.

Whenever the load current is reduced to a level less than half the peak-to-peak inductor ripple current, the device enters discontinuous conduction mode (DCM). Calculate the critical conduction boundary using [Equation 6](#).

$$I_{\text{BOUNDARY}} = \frac{\Delta I_L}{2} = \frac{V_{\text{OUT}} \cdot (1-D)}{2 \cdot L_F \cdot F_{\text{SW}}} \quad (6)$$

When the inductor current reaches zero, the SW node becomes high impedance. Resonant ringing occurs at SW as a result of the LC tank circuit formed by the buck inductor and the parasitic capacitance at the SW node. At light loads, several pulses may be skipped in between switching cycles, effectively reducing the switching frequency and further improving light-load efficiency.

8 Application and Implementation

NOTE

Information in the following applications sections is not part of the TI component specification, and TI does not warrant its accuracy or completeness. TI's customers are responsible for determining suitability of components for their purposes. Customers should validate and test their design implementation to confirm system functionality.

8.1 Application Information

LM5008A requires only a few external components to convert from a wide range of supply voltages to a fixed output voltage. To expedite and streamline the process of designing a LM5008A-based converter, a comprehensive [LM5008A Quick-Start](#) tool is available for download to assist the designer with component selection for a given application. [WEBENCH®](#) online software is also available to generate complete designs, leveraging iterative design procedures and access to comprehensive component databases. The following sections discuss a design procedure using a typical application example. [Figure 10](#) shows the LM5008A in a configuration suitable for several application use cases. See the [LM5008A EVM](#) for more details.

8.2 Typical Application

The final circuit is shown in [Figure 10](#). The circuit was tested, and the resulting performance is shown in [Figure 14](#) and [Figure 15](#).

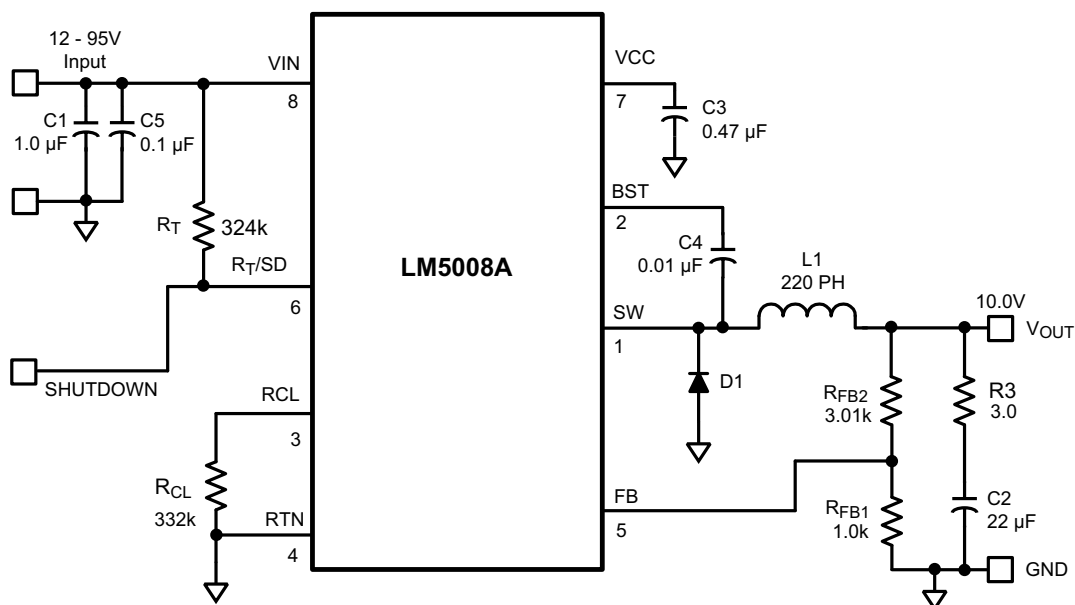

Copyright © 2016, Texas Instruments Incorporated

Figure 10. LM5008A Example Circuit

8.2.1 Design Requirements

A guide for determining the component values is shown in [Figure 10](#). [Table 1](#) lists the bill of materials for this application example. The following steps configure the LM5008A:

- Input voltage range (V_{IN}): 12 V to 95 V
- Output voltage (V_{OUT1}): 10 V
- Load current (for continuous conduction mode): 100 mA to 300 mA

Typical Application (continued)

Table 1. Bill of Materials

ITEM	DESCRIPTION	PART NUMBER	VALUE
C1	Ceramic Capacitor	TDK C4532X7R2A105M	1 μ F, 100 V
C2	Ceramic Capacitor	TDK C4532X7R1E226M	22 μ F, 25 V
C3	Ceramic Capacitor	Kemet C1206C474K5RAC	0.47 μ F, 50 V
C4	Ceramic Capacitor	Kemet C1206C103K5RAC	0.01 μ F, 50 V
C5	Ceramic Capacitor	TDK C3216X7R2A104M	0.1 μ F, 100 V
D1	Schottky Power Diode	Diodes Inc. DFLS1100	100 V, 1 A
L1	Power Inductor	COILTRONICS DR125-221-R or TDK SLF10145T-221MR65	220 μ H
R _{FB2}	Resistor	Vishay CRCW12063011F	3.01 k Ω
R _{FB1}	Resistor	Vishay CRCW12061001F	1.0 k Ω
R3	Resistor	Vishay CRCW12063R00F	3.0 Ω
R _T	Resistor	Vishay CRCW12063243F	324 k Ω
R _{CL}	Resistor	Vishay CRCW12063323F	332 k Ω
U1	Switching Regulator	LM5008A	

8.2.2 Detailed Design Procedure

8.2.2.1 Custom Design With WEBENCH® Tools

[Click here](#) to create a custom design using the LM5008A device with the WEBENCH® Power Designer.

1. Start by entering the input voltage (V_{IN}), output voltage (V_{OUT}), and output current (I_{OUT}) requirements.
2. Optimize the design for key parameters such as efficiency, footprint, and cost using the optimizer dial.
3. Compare the generated design with other possible solutions from Texas Instruments.

The WEBENCH Power Designer provides a customized schematic along with a list of materials with real-time pricing and component availability.

In most cases, these actions are available:

- Run electrical simulations to see important waveforms and circuit performance
- Run thermal simulations to understand board thermal performance
- Export customized schematic and layout into popular CAD formats
- Print PDF reports for the design, and share the design with colleagues

Get more information about WEBENCH tools at www.ti.com/WEBENCH.

8.2.2.2 Selection Of External Components

R_{FB1}, R_{FB2}: $V_{OUT} = V_{FB} \times (R_{FB1} + R_{FB2}) / R_{FB1}$, and because $V_{FB} = 2.5$ V, the ratio of R_{FB2} to R_{FB1} calculates as 3:1. Standard values of 3.01 k Ω and 1 k Ω are chosen. Other values could be used as long as the 3:1 ratio is maintained.

F_s and R_T: The recommended operating frequency range for the LM5008A is 50 kHz to 1.1 MHz. Unless the application requires a specific frequency, the choice of frequency is generally a compromise because it affects the size of L1 and C2 and the switching losses. The maximum allowed frequency, based on a minimum on-time of 400 ns, is calculated with [Equation 7](#).

$$F_{MAX} = V_{OUT} / (V_{INMAX} \times 400 \text{ ns}) \quad (7)$$

For this exercise, $F_{MAX} = 263$ kHz. From [Equation 2](#), R_T calculates to 274 k Ω . A standard value 324-k Ω resistor is used to allow for tolerances in [Equation 2](#), resulting in a frequency of 223 kHz.

L1: The main parameter affected by the inductor is the output current ripple amplitude. The choice of inductor value therefore depends on both the minimum and maximum load currents, keeping in mind that the maximum ripple current occurs at maximum V_{IN} .

- a. **Minimum load current:** To maintain continuous conduction at minimum I_o (100 mA), the ripple amplitude

(I_{OR}) must be less than 200 mA p-p so the lower peak of the waveform does not reach zero. L1 is calculated using Equation 8.

$$L1 = \frac{V_{OUT} \times (V_{IN} - V_{OUT})}{I_{OR} \times F_s \times V_{IN}} \quad (8)$$

At $V_{IN} = 95$ V, L1 (minimum) calculates to 200 μ H. The next larger standard value (220 μ H) is chosen and with this value I_{OR} calculates to 182 mA p-p at $V_{IN} = 95$ V, and 34 mA p-p at $V_{IN} = 12$ V.

- b. **Maximum load current:** At a load current of 300 mA, the peak of the ripple waveform must not reach the minimum value of the LM5008A's current limit threshold (410 mA). Therefore the ripple amplitude must be less than 220 mA p-p, which is already satisfied in Equation 8. With L1 = 220 μ H, at maximum V_{IN} and I_O , the peak of the ripple is 391 mA. While L1 must carry this peak current without saturating or exceeding its temperature rating, it also must be capable of carrying the maximum value of the LM5008A's current limit threshold (610 mA) without saturating because the current limit is reached during start-up.

The DC resistance of the inductor must be as low as possible. For example, if the inductor's DCR is 1 Ω , the power dissipated at maximum load current is 0.09 W. While small, it is not insignificant compared to the load power of 3 W.

C3: The capacitor on the V_{CC} output provides not only noise filtering and stability, but its primary purpose is to prevent false triggering of the V_{CC} UVLO at the buck switch on and off transitions. C3 must be no smaller than 0.47 μ F.

C2, and R3: When selecting the output filter capacitor C2, the items to consider are ripple voltage due to its ESR, ripple voltage due to its capacitance, and the nature of the load.

ESR and R3: A low ESR for C2 is generally desirable to minimize power losses and heating within the capacitor. However, the regulator requires a minimum amount of ripple voltage at the feedback input for proper loop operation. For the LM5008A the minimum ripple required at pin 5 is 25 mV p-p, requiring a minimum ripple at V_{OUT} of 100 mV. Because the minimum ripple current (at minimum V_{IN}) is 34 mA p-p, the minimum ESR required at V_{OUT} is 100 mV / 34 mA = 2.94 Ω . Because quality capacitors for SMPS applications have an ESR considerably less than this, R3 is inserted as shown in the *Functional Block Diagram*. R3's value, along with C2's ESR, must result in at least 25 mV p-p ripple at pin 5. Generally, R3 is 0.5 to 3 Ω .

R_{CL}: When current limit is detected, the minimum off-time set by this resistor must be greater than the maximum normal off-time, which occurs at maximum input voltage. Using Equation 4, the minimum on-time is 472 ns, yielding an off-time of 4 μ s (at 223 kHz). Due to the 25% tolerance on the on-time, the off-time tolerance is also 25%, yielding a maximum off-time of 5 μ s. Allowing for the response time of the current limit detection circuit (350 ns) increases the maximum off-time to 5.35 μ s. This is increased an additional 25% to 6.7 μ s to allow for the tolerances of Equation 5. Using Equation 5, R_{CL} calculates to 325 k Ω at $V_{FB} = 2.5$ V. A standard value 332-k Ω resistor is used.

D1: The important parameters are reverse recovery time and forward voltage. The reverse recovery time determines how long the reverse current surge lasts each time the buck switch is turned on. The forward voltage drop is significant in the event the output is short-circuited as it is only this diode's voltage which forces the inductor current to reduce during the forced off-time. For this reason, a higher voltage is better, although that affects efficiency. A good choice is a Schottky power diode, such as the DFSL1100. D1's reverse voltage rating must be at least as great as the maximum V_{IN} , and its current rating be greater than the maximum current limit threshold (610 mA).

C1: This capacitor's purpose is to supply most of the switch current during the on-time, and limit the voltage ripple at V_{IN} , on the assumption that the voltage source feeding V_{IN} has an output impedance greater than zero. At maximum load current, when the buck switch turns on, the current into pin 8 suddenly increases to the lower peak of the output current waveform, ramp up to the peak value, then drop to zero at turnoff. The average input current during this on-time is the load current (300 mA). For a worst-case calculation, C1 must supply this average load current during the maximum on-time. To keep the input voltage ripple to less than 2 V (for this exercise), C1 is calculated with Equation 9.

$$C1 = \frac{I \times t_{ON}}{\Delta V} = \frac{0.3A \times 3.74 \mu S}{2.0V} = 0.56 \mu F \quad (9)$$

Quality ceramic capacitors in this value have a low ESR which adds only a few millivolts to the ripple. It is the capacitance which is dominant in this case. To allow for the capacitor's tolerance, temperature effects, and voltage effects, a 1- μ F, 100-V, X7R capacitor is used.

C4: The recommended value is 0.01 μF for C4, as this is appropriate in the majority of applications. A high-quality ceramic capacitor with low ESR is recommended as C4 supplies the surge current to charge the buck switch gate at turnon. A low ESR also ensures a quick recharge during each off-time. At minimum V_{IN} , when the on-time is at maximum, it is possible during start-up that C4 does not fully recharge during each 300-ns off-time. The circuit is not able to complete the start-up, and achieve output regulation. This can occur when the frequency is intended to be low (for example, $R_{\text{T}} = 500 \text{ K}$). In this case C4 must be increased so it can maintain sufficient voltage across the buck switch driver during each on-time.

C5: This capacitor helps avoid supply voltage transients and ringing due to long lead inductance at V_{IN} . A low-ESR, 0.1- μF ceramic chip capacitor is recommended placed close to the LM5008A.

8.2.2.3 Low-Output Ripple Configurations

For applications where low-output ripple is required, the following options can be used to reduce or nearly eliminate the ripple:

- a. **Reduced ripple configuration:** In [Figure 11](#), Cff is added across R_{FB2} to AC-couple the ripple at V_{OUT} directly to the FB pin. This allows the ripple at V_{OUT} to be reduced to a minimum of 25 mVp-p by reducing R3, because the ripple at V_{OUT} is not attenuated by the feedback resistors. The minimum value for Cff is determined by [Equation 10](#):

$$C_{\text{ff}} = \frac{3 \times t_{\text{ON}(\text{max})}}{(R_{\text{FB1}} // R_{\text{FB2}})}$$

where

- $t_{\text{ON}(\text{max})}$ is the maximum on-time, which occurs at $V_{\text{IN}(\text{min})}$. The next larger standard value capacitor must be used for Cff. (10)

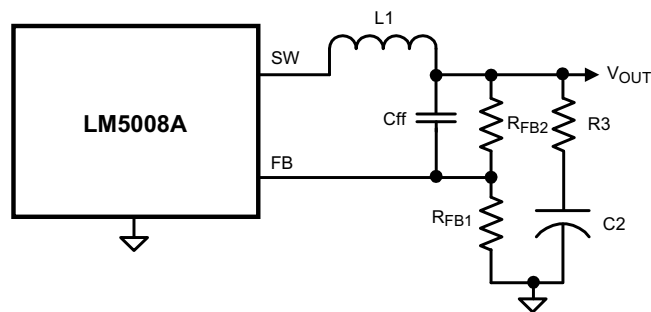

Copyright © 2016, Texas Instruments Incorporated

Figure 11. Reduced Ripple Configuration

- b. **Minimum ripple configuration:** If the application requires a lower value of ripple ($<10 \text{ mVp-p}$), the circuit of [Figure 12](#) can be used. R3 is removed, and the resulting output ripple voltage is determined by the inductor's ripple current and C2's characteristics. RA and CA are chosen to generate a sawtooth waveform at their junction, and that voltage is AC-coupled to the FB pin through CB. To determine the values for RA, CA, and CB, use the following procedure in [Equation 11](#):

$$\text{Calculate } V_{\text{A}} = V_{\text{OUT}} - (V_{\text{SW}} \times (1 - (V_{\text{OUT}}/V_{\text{IN}(\text{min})}))$$

where

- V_{SW} is the absolute value of the voltage at the SW pin during the off-time (typically 1 V). V_{A} is the DC voltage at the RA/CA junction, and is used in [Equation 12](#). (11)

$$\text{Calculate } RA \times CA = (V_{\text{IN}(\text{min})} - V_{\text{A}}) \times t_{\text{ON}}/\Delta V$$

where

- t_{ON} is the maximum on-time (at minimum input voltage), and ΔV is the desired ripple amplitude at the RA/CA junction (typically 40-50 mV). RA and CA are then chosen from standard value components to satisfy the above product. Typically CA is 1000 pF to 5000 pF, and RA is 10 k Ω to 300 k Ω . CB is then chosen large compared to CA, typically 0.1 μF . (12)

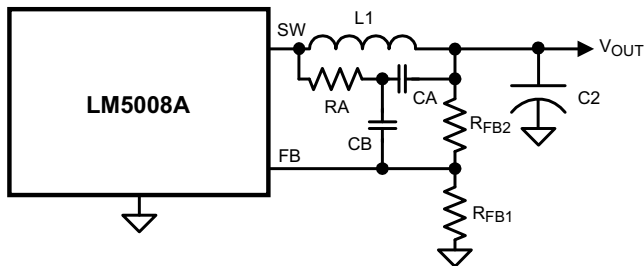

Copyright © 2016, Texas Instruments Incorporated

Figure 12. Minimum Output Ripple Using Ripple Injection

- c. **Alternate minimum ripple configuration:** The circuit in Figure 13 is the same as that in the *Functional Block Diagram*, except the output voltage is taken from the junction of R3 and C2. The ripple at V_{OUT} is determined by the inductor's ripple current and C2's characteristics. However, R3 slightly degrades the load regulation. This circuit may be suitable if the load current is fairly constant.

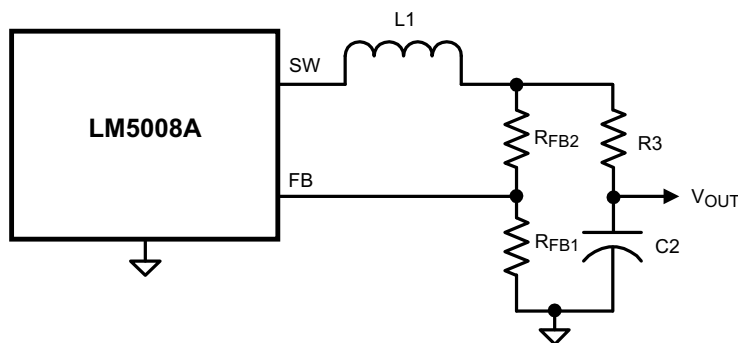

Copyright © 2016, Texas Instruments Incorporated

Figure 13. Alternate Minimum Output Ripple Configuration

8.2.3 Application Curves

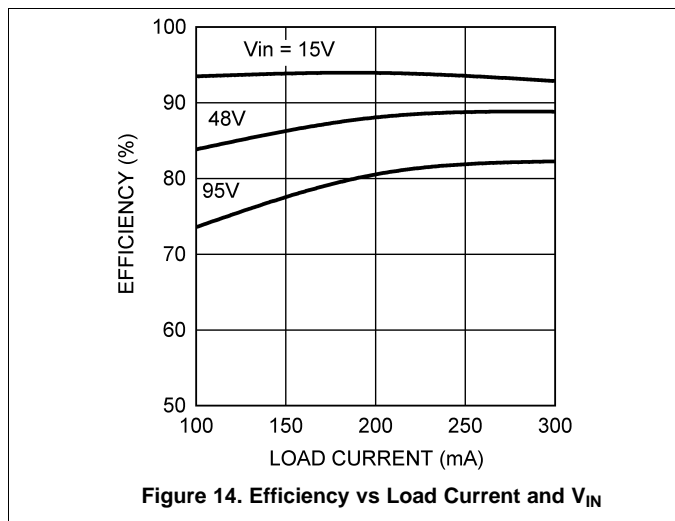

Figure 14. Efficiency vs Load Current and V_{IN}

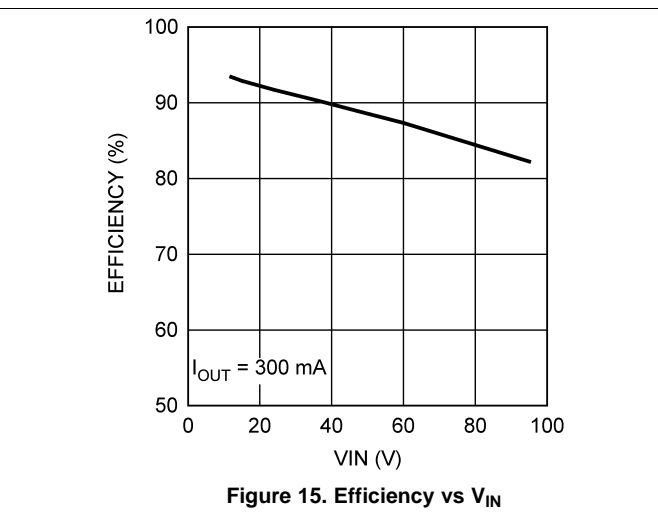

Figure 15. Efficiency vs V_{IN}

9 Power Supply Recommendations

The LM5008A converter is designed to operate from a wide input voltage range from 6 V to 95 V. The characteristics of the input supply must be compatible with the [Absolute Maximum Ratings](#) and [Recommended Operating Conditions](#). In addition, the input supply must be capable of delivering the required input current to the fully-loaded regulator. Estimate the average input current with [Equation 13](#).

$$I_{IN} = \frac{V_{OUT} \cdot I_{OUT}}{V_{IN} \cdot \eta}$$

where

- η is the efficiency (13)

If the converter is connected to an input supply through long wires or PCB traces with large impedance, special care is required to achieve stable performance. The parasitic inductance and resistance of the input cables may have an adverse affect on converter operation. The parasitic inductance in combination with the low-ESR ceramic input capacitors form an underdamped resonant circuit. This circuit can cause overvoltage transients at VIN each time the input supply is cycled ON and OFF. The parasitic resistance causes the input voltage to dip during a load transient. If the regulator is operating close to the minimum input voltage, this dip can cause false UVLO fault triggering and a system reset. The best way to solve such issues is to reduce the distance from the input supply to the regulator and use an aluminum or tantalum input capacitor in parallel with the ceramics. The moderate ESR of the electrolytic capacitors helps to damp the input resonant circuit and reduce any voltage overshoots. A capacitance in the range of 10 μ F to 47 μ F is usually sufficient to provide input damping and helps to hold the input voltage steady during large load transients.

An EMI input filter is often used in front of the regulator that, unless carefully designed, can lead to instability as well as some of the effects mentioned above. The user's guide [Simple Success With Conducted EMI for DC-DC Converters](#) (SNVA489) provides helpful suggestions when designing an input filter for any switching regulator.

10 Layout

10.1 Layout Guidelines

The LM5008A regulation and overvoltage comparators are very fast, and as such responds to short-duration noise pulses. Layout considerations are therefore critical for optimum performance:

1. Minimize the area of the high di/dt switching current loop consisting of the VIN pin, input ceramic capacitor, SW node and freewheeling power diode. Keep the input capacitor as close as possible to the VIN pin and route a short, direct connection to the RTN pin using polygon copper pours.
2. Minimize SW copper area to reduce radiated noise related to high dv/dt.
3. Locate all components as physically close as possible to their respective pins, thereby minimizing noise pickup in the printed-circuit tracks.
4. The FB trace should be away from noise sources and inductors. The lower feedback resistor should connect to ground close to the IC RTN.

If the internal dissipation of the LM5008A converter produces excessive junction temperatures during normal operation, optimal use of the PCB ground plane can help considerably to dissipate heat. The exposed pad on the bottom of the WSON-8 package can be soldered to a ground plane on the PCB, and that plane should extend out from beneath the IC to help dissipate the heat. Additionally, the use of wide PCB traces for power connection can also help conduct heat away from the IC. Judicious positioning of the LM5008A converter within the end product, along with use of any available air flow (forced or natural convection), can help reduce the operating junction temperature.

10.2 Layout Example

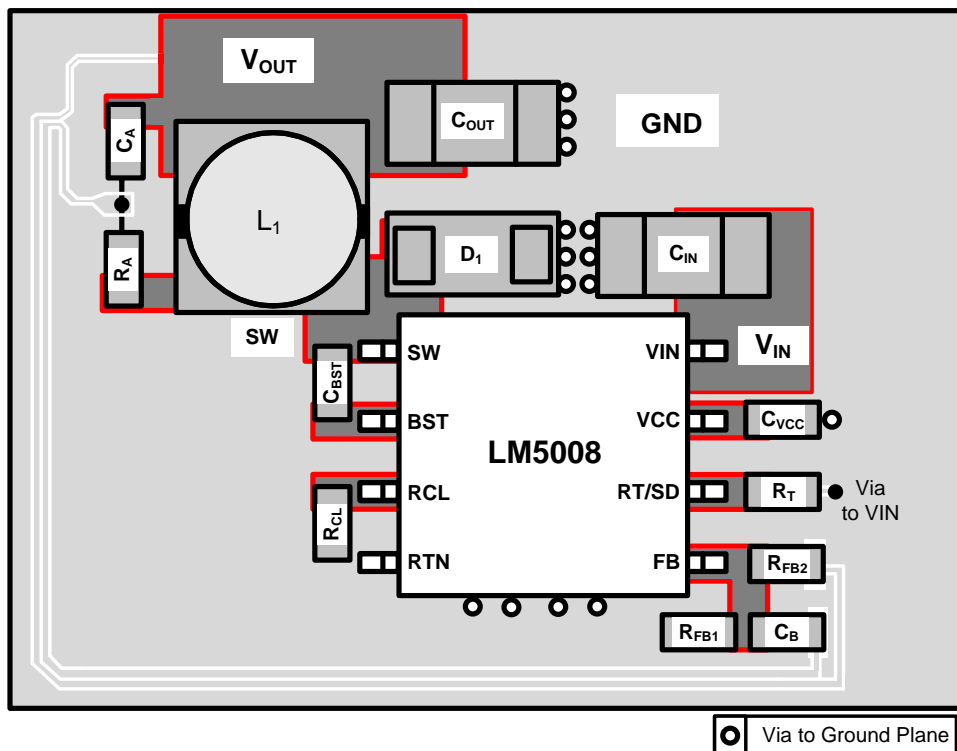

Figure 16. LM5008A PCB Layout Example

11 Device and Documentation Support

11.1 Device Support

11.1.1 Third-Party Products Disclaimer

TI'S PUBLICATION OF INFORMATION REGARDING THIRD-PARTY PRODUCTS OR SERVICES DOES NOT CONSTITUTE AN ENDORSEMENT REGARDING THE SUITABILITY OF SUCH PRODUCTS OR SERVICES OR A WARRANTY, REPRESENTATION OR ENDORSEMENT OF SUCH PRODUCTS OR SERVICES, EITHER ALONE OR IN COMBINATION WITH ANY TI PRODUCT OR SERVICE.

11.1.2 Custom Design With WEBENCH® Tools

[Click here](#) to create a custom design using the LM5008A device with the WEBENCH® Power Designer.

1. Start by entering the input voltage (V_{IN}), output voltage (V_{OUT}), and output current (I_{OUT}) requirements.
2. Optimize the design for key parameters such as efficiency, footprint, and cost using the optimizer dial.
3. Compare the generated design with other possible solutions from Texas Instruments.

The WEBENCH Power Designer provides a customized schematic along with a list of materials with real-time pricing and component availability.

In most cases, these actions are available:

- Run electrical simulations to see important waveforms and circuit performance
- Run thermal simulations to understand board thermal performance
- Export customized schematic and layout into popular CAD formats
- Print PDF reports for the design, and share the design with colleagues

Get more information about WEBENCH tools at www.ti.com/WEBENCH.

11.1.3 Development Support

For development support see the following:

- For TI's reference design library, visit [TI Designs](#)
- For TI's WEBENCH Design Environments, visit [WEBENCH® Design Center](#)
- For selecting components in LM5008A applications, see the [LM5008A Quick-Start Calculator](#)

11.2 Documentation Support

11.2.1 Related Documentation

For related documentation see the following:

- [LM5008 Quick-start Calculator](#)
- [AN-1925 LM5008A Evaluation Board](#) (SNVA380)
- [AN-1330 LM5008 Evaluation Board](#) (SNVA090)
- [Buck Regulator Topologies for Wide Input/Output Voltage Differentials](#) (SNVA594)
- White Papers:
 - [Valuing Wide \$V_{IN}\$, Low EMI Synchronous Buck Circuits for Cost-driven, Demanding Applications](#)
 - [An Overview of Conducted EMI Specifications for Power Supplies](#)
 - [An Overview of Radiated EMI Specifications for Power Supplies](#)

11.2.1.1 PCB Layout Resources

- [AN-1149 Layout Guidelines for Switching Power Supplies](#) (SNVA021)
- [AN-1229 Simple Switcher PCB Layout Guidelines](#) (SNVA054)
- [Constructing Your Power Supply – Layout Considerations](#) (SLUP230)
- [Low Radiated EMI Layout Made SIMPLE with LM4360x and LM4600x](#) (SNVA721)
- [AN-2162 Simple Success With Conducted EMI From DC-DC Converters](#) (SNVA489)
- [Reduce Buck-Converter EMI and Voltage Stress by Minimizing Inductive Parasitics](#) (SLYT682)

Documentation Support (continued)

- Power House Blogs:
 - [High-Density PCB Layout of DC/DC Converters](#)

11.2.1.2 Thermal Design Resources

- [AN-2020 Thermal Design By Insight, Not Hindsight](#) (SNVA419)
- [AN-1520 A Guide to Board Layout for Best Thermal Resistance for Exposed Pad Packages](#) (SNVA183)
- [Semiconductor and IC Package Thermal Metrics](#) (SPRA953)
- [Thermal Design Made Simple with LM43603 and LM43602](#) (SNVA719)
- [PowerPAD™ Thermally Enhanced Package](#) (SLMA002)
- [PowerPAD Made Easy](#) (SLMA004)
- [Using New Thermal Metrics](#) (SBVA025)

11.3 Receiving Notification of Documentation Updates

To receive notification of documentation updates, navigate to the device product folder on ti.com. In the upper right corner, click on *Alert me* to register and receive a weekly digest of any product information that has changed. For change details, review the revision history included in any revised document.

11.4 Community Resources

The following links connect to TI community resources. Linked contents are provided "AS IS" by the respective contributors. They do not constitute TI specifications and do not necessarily reflect TI's views; see TI's [Terms of Use](#).

TI E2E™ Online Community *TI's Engineer-to-Engineer (E2E) Community*. Created to foster collaboration among engineers. At e2e.ti.com, you can ask questions, share knowledge, explore ideas and help solve problems with fellow engineers.

Design Support *TI's Design Support* Quickly find helpful E2E forums along with design support tools and contact information for technical support.

11.5 Trademarks

PowerPAD, E2E are trademarks of Texas Instruments.
WEBENCH is a registered trademark of Texas Instruments.
All other trademarks are the property of their respective owners.

11.6 Electrostatic Discharge Caution



These devices have limited built-in ESD protection. The leads should be shorted together or the device placed in conductive foam during storage or handling to prevent electrostatic damage to the MOS gates.

11.7 Glossary

[SLYZ022](#) — *TI Glossary*.

This glossary lists and explains terms, acronyms, and definitions.

12 Mechanical, Packaging, and Orderable Information

The following pages include mechanical, packaging, and orderable information. This information is the most current data available for the designated devices. This data is subject to change without notice and revision of this document. For browser-based versions of this data sheet, refer to the left-hand navigation.

PACKAGING INFORMATION

Orderable Device	Status (1)	Package Type	Package Drawing	Pins	Package Qty	Eco Plan (2)	Lead finish/ Ball material (6)	MSL Peak Temp (3)	Op Temp (°C)	Device Marking (4/5)	Samples
LM5008AMM/NOPB	ACTIVE	VSSOP	DGK	8	1000	RoHS & Green	SN	Level-1-260C-UNLIM	-40 to 125	SAYA	Samples
LM5008AMMX/NOPB	ACTIVE	VSSOP	DGK	8	3500	RoHS & Green	SN	Level-1-260C-UNLIM	-40 to 125	SAYA	Samples
LM5008ASD/NOPB	ACTIVE	WSO	NGU	8	1000	RoHS & Green	NIPDAU SN	Level-1-260C-UNLIM	-40 to 125	L00070A	Samples
LM5008ASDX/NOPB	ACTIVE	WSO	NGU	8	4500	RoHS & Green	SN	Level-1-260C-UNLIM	-40 to 125	L00070A	Samples

(1) The marketing status values are defined as follows:

ACTIVE: Product device recommended for new designs.

LIFEBUY: TI has announced that the device will be discontinued, and a lifetime-buy period is in effect.

NRND: Not recommended for new designs. Device is in production to support existing customers, but TI does not recommend using this part in a new design.

PREVIEW: Device has been announced but is not in production. Samples may or may not be available.

OBSOLETE: TI has discontinued the production of the device.

(2) **RoHS:** TI defines "RoHS" to mean semiconductor products that are compliant with the current EU RoHS requirements for all 10 RoHS substances, including the requirement that RoHS substance do not exceed 0.1% by weight in homogeneous materials. Where designed to be soldered at high temperatures, "RoHS" products are suitable for use in specified lead-free processes. TI may reference these types of products as "Pb-Free".

RoHS Exempt: TI defines "RoHS Exempt" to mean products that contain lead but are compliant with EU RoHS pursuant to a specific EU RoHS exemption.

Green: TI defines "Green" to mean the content of Chlorine (Cl) and Bromine (Br) based flame retardants meet JS709B low halogen requirements of <=1000ppm threshold. Antimony trioxide based flame retardants must also meet the <=1000ppm threshold requirement.

(3) **MSL, Peak Temp.** - The Moisture Sensitivity Level rating according to the JEDEC industry standard classifications, and peak solder temperature.

(4) There may be additional marking, which relates to the logo, the lot trace code information, or the environmental category on the device.

(5) Multiple Device Markings will be inside parentheses. Only one Device Marking contained in parentheses and separated by a "-" will appear on a device. If a line is indented then it is a continuation of the previous line and the two combined represent the entire Device Marking for that device.

(6) **Lead finish/Ball material** - Orderable Devices may have multiple material finish options. Finish options are separated by a vertical ruled line. Lead finish/Ball material values may wrap to two lines if the finish value exceeds the maximum column width.

Important Information and Disclaimer: The information provided on this page represents TI's knowledge and belief as of the date that it is provided. TI bases its knowledge and belief on information provided by third parties, and makes no representation or warranty as to the accuracy of such information. Efforts are underway to better integrate information from third parties. TI has taken and

continues to take reasonable steps to provide representative and accurate information but may not have conducted destructive testing or chemical analysis on incoming materials and chemicals. TI and TI suppliers consider certain information to be proprietary, and thus CAS numbers and other limited information may not be available for release.

In no event shall TI's liability arising out of such information exceed the total purchase price of the TI part(s) at issue in this document sold by TI to Customer on an annual basis.

TAPE AND REEL INFORMATION

QUADRANT ASSIGNMENTS FOR PIN 1 ORIENTATION IN TAPE

*All dimensions are nominal

Device	Package Type	Package Drawing	Pins	SPQ	Reel Diameter (mm)	Reel Width W1 (mm)	A0 (mm)	B0 (mm)	K0 (mm)	P1 (mm)	W (mm)	Pin1 Quadrant
LM5008AMM/NOPB	VSSOP	DGK	8	1000	178.0	12.4	5.3	3.4	1.4	8.0	12.0	Q1
LM5008AMMX/NOPB	VSSOP	DGK	8	3500	330.0	12.4	5.3	3.4	1.4	8.0	12.0	Q1
LM5008ASD/NOPB	WSO8	NGU	8	1000	178.0	12.4	4.3	4.3	1.3	8.0	12.0	Q1
LM5008ASDX/NOPB	WSO8	NGU	8	4500	330.0	12.4	4.3	4.3	1.3	8.0	12.0	Q1

TAPE AND REEL BOX DIMENSIONS



*All dimensions are nominal

Device	Package Type	Package Drawing	Pins	SPQ	Length (mm)	Width (mm)	Height (mm)
LM5008AMM/NOPB	VSSOP	DGK	8	1000	208.0	191.0	35.0
LM5008AMMX/NOPB	VSSOP	DGK	8	3500	367.0	367.0	35.0
LM5008ASD/NOPB	WSON	NGU	8	1000	208.0	191.0	35.0
LM5008ASDX/NOPB	WSON	NGU	8	4500	367.0	367.0	35.0

DGK0008A



PACKAGE OUTLINE

VSSOP - 1.1 mm max height

SMALL OUTLINE PACKAGE



NOTES:

PowerPAD is a trademark of Texas Instruments.

1. All linear dimensions are in millimeters. Any dimensions in parenthesis are for reference only. Dimensioning and tolerancing per ASME Y14.5M.
2. This drawing is subject to change without notice.
3. This dimension does not include mold flash, protrusions, or gate burrs. Mold flash, protrusions, or gate burrs shall not exceed 0.15 mm per side.
4. This dimension does not include interlead flash. Interlead flash shall not exceed 0.25 mm per side.
5. Reference JEDEC registration MO-187.

EXAMPLE BOARD LAYOUT

DGK0008A

™ VSSOP - 1.1 mm max height

SMALL OUTLINE PACKAGE

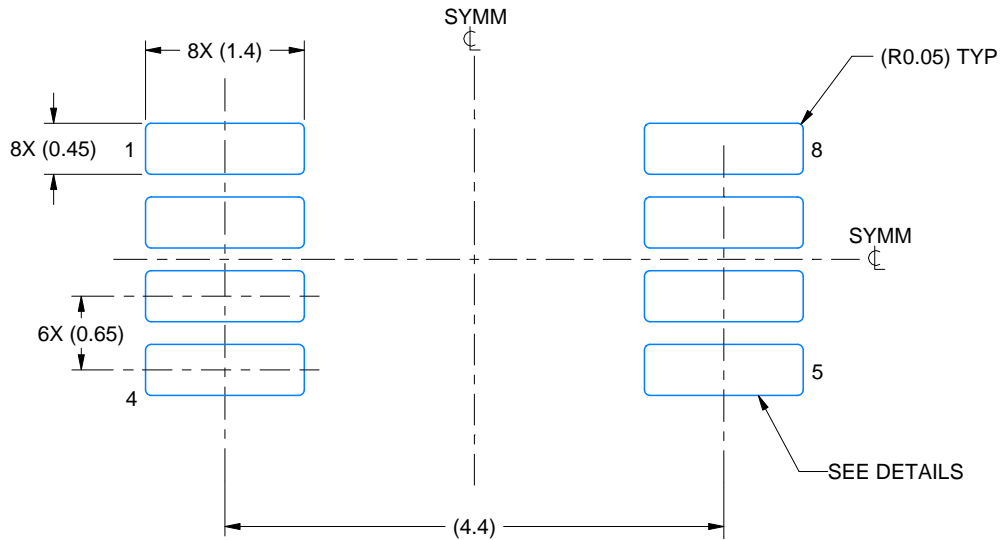

LAND PATTERN EXAMPLE
EXPOSED METAL SHOWN
SCALE: 15X

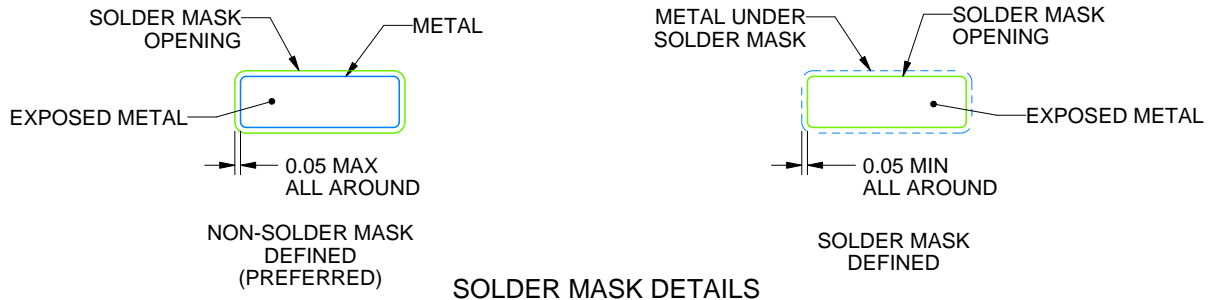

SOLDER MASK DETAILS

4214862/A 04/2023

NOTES: (continued)

6. Publication IPC-7351 may have alternate designs.
7. Solder mask tolerances between and around signal pads can vary based on board fabrication site.
8. Vias are optional depending on application, refer to device data sheet. If any vias are implemented, refer to their locations shown on this view. It is recommended that vias under paste be filled, plugged or tented.
9. Size of metal pad may vary due to creepage requirement.

EXAMPLE STENCIL DESIGN

DGK0008A

™ VSSOP - 1.1 mm max height

SMALL OUTLINE PACKAGE



SOLDER PASTE EXAMPLE
SCALE: 15X

4214862/A 04/2023

NOTES: (continued)

11. Laser cutting apertures with trapezoidal walls and rounded corners may offer better paste release. IPC-7525 may have alternate design recommendations.
12. Board assembly site may have different recommendations for stencil design.

NGU0008B

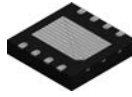

PACKAGE OUTLINE

WSON - 0.8 mm max height

PLASTIC SMALL OUTLINE - NO LEAD

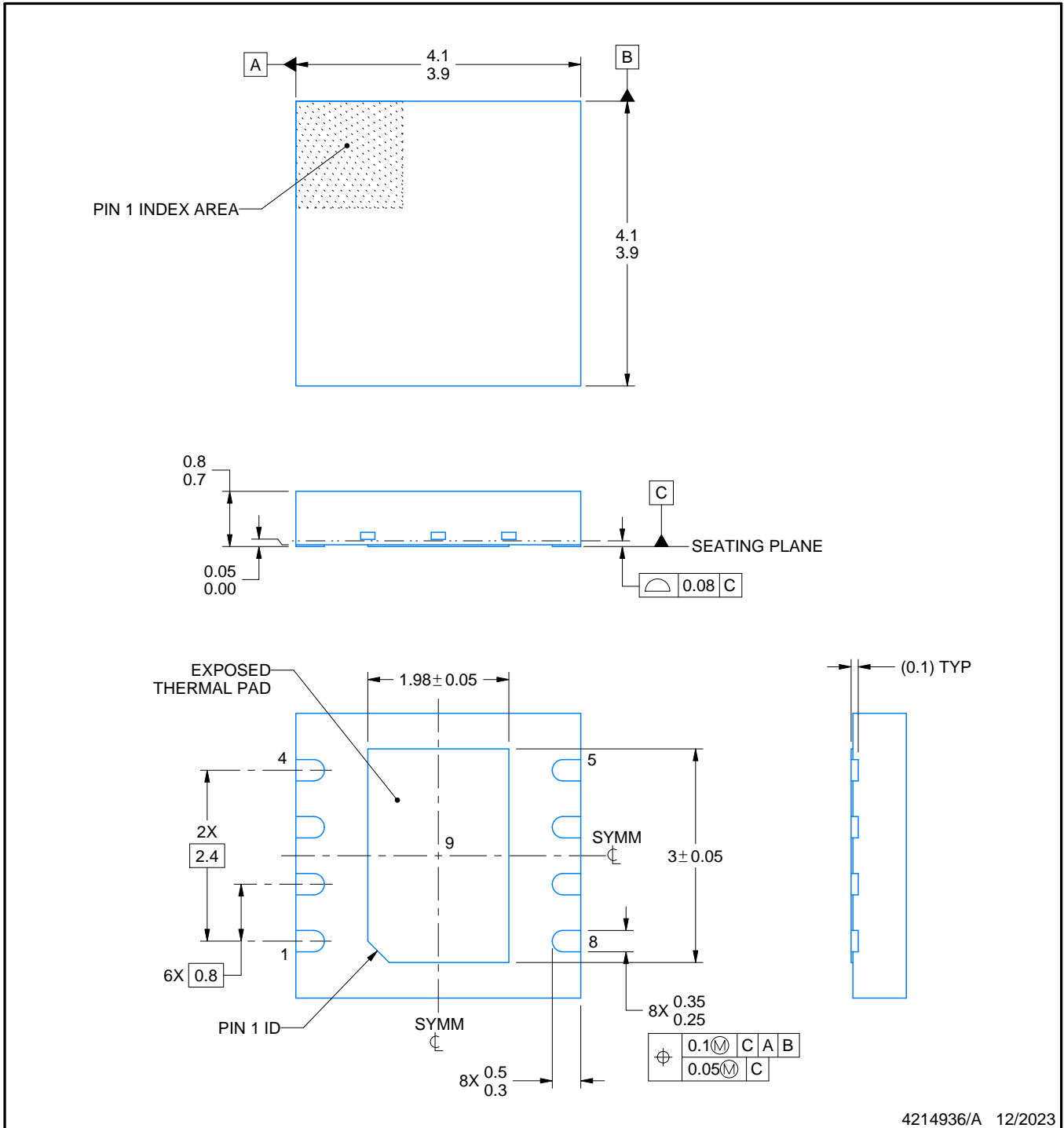

4214936/A 12/2023

NOTES:

1. All linear dimensions are in millimeters. Any dimensions in parenthesis are for reference only. Dimensioning and tolerancing per ASME Y14.5M.
2. This drawing is subject to change without notice.
3. The package thermal pad must be soldered to the printed circuit board for thermal and mechanical performance.

EXAMPLE BOARD LAYOUT

NGU0008B

WSON - 0.8 mm max height

PLASTIC SMALL OUTLINE - NO LEAD

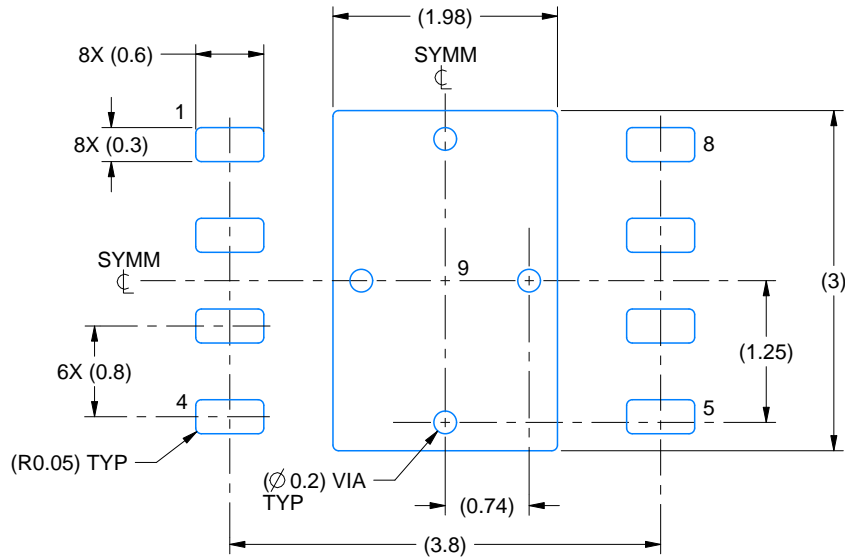

LAND PATTERN EXAMPLE
EXPOSED METAL SHOWN
SCALE:15X

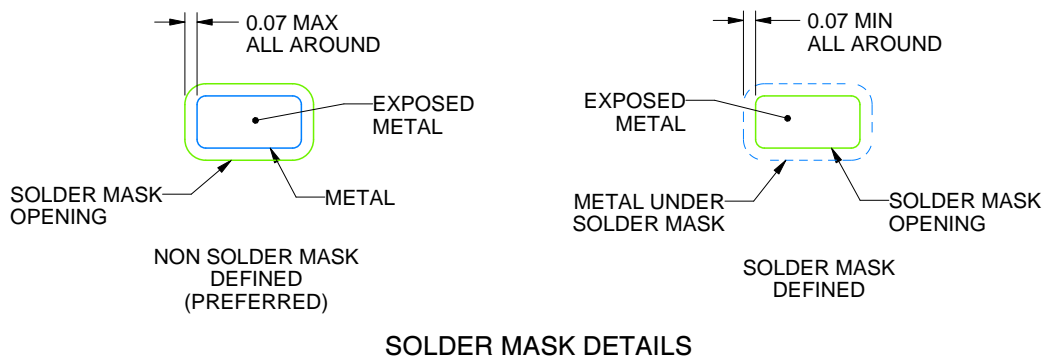

SOLDER MASK DETAILS

4214936/A 12/2023

NOTES: (continued)

4. This package is designed to be soldered to a thermal pad on the board. For more information, see Texas Instruments literature number SLUA271 (www.ti.com/lit/sluea271).
5. Vias are optional depending on application, refer to device data sheet. If any vias are implemented, refer to their locations shown on this view. It is recommended that vias under paste be filled, plugged or tented.

EXAMPLE STENCIL DESIGN

NGU0008B

WSON - 0.8 mm max height

PLASTIC SMALL OUTLINE - NO LEAD

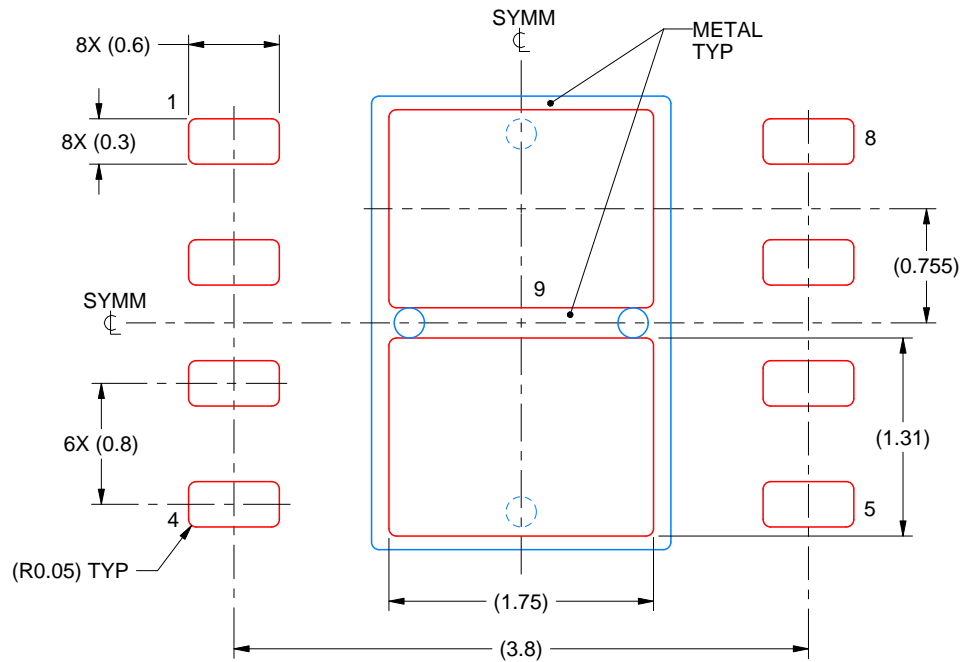

SOLDER PASTE EXAMPLE
BASED ON 0.125 mm THICK STENCIL

EXPOSED PAD 9:
77% PRINTED SOLDER COVERAGE BY AREA UNDER PACKAGE
SCALE:20X

4214936/A 12/2023

NOTES: (continued)

6. Laser cutting apertures with trapezoidal walls and rounded corners may offer better paste release. IPC-7525 may have alternate design recommendations.

IMPORTANT NOTICE AND DISCLAIMER

TI PROVIDES TECHNICAL AND RELIABILITY DATA (INCLUDING DATA SHEETS), DESIGN RESOURCES (INCLUDING REFERENCE DESIGNS), APPLICATION OR OTHER DESIGN ADVICE, WEB TOOLS, SAFETY INFORMATION, AND OTHER RESOURCES "AS IS" AND WITH ALL FAULTS, AND DISCLAIMS ALL WARRANTIES, EXPRESS AND IMPLIED, INCLUDING WITHOUT LIMITATION ANY IMPLIED WARRANTIES OF MERCHANTABILITY, FITNESS FOR A PARTICULAR PURPOSE OR NON-INFRINGEMENT OF THIRD PARTY INTELLECTUAL PROPERTY RIGHTS.

These resources are intended for skilled developers designing with TI products. You are solely responsible for (1) selecting the appropriate TI products for your application, (2) designing, validating and testing your application, and (3) ensuring your application meets applicable standards, and any other safety, security, regulatory or other requirements.

These resources are subject to change without notice. TI grants you permission to use these resources only for development of an application that uses the TI products described in the resource. Other reproduction and display of these resources is prohibited. No license is granted to any other TI intellectual property right or to any third party intellectual property right. TI disclaims responsibility for, and you will fully indemnify TI and its representatives against, any claims, damages, costs, losses, and liabilities arising out of your use of these resources.

TI's products are provided subject to [TI's Terms of Sale](#) or other applicable terms available either on [ti.com](https://www.ti.com) or provided in conjunction with such TI products. TI's provision of these resources does not expand or otherwise alter TI's applicable warranties or warranty disclaimers for TI products.

TI objects to and rejects any additional or different terms you may have proposed.

Mailing Address: Texas Instruments, Post Office Box 655303, Dallas, Texas 75265
Copyright © 2024, Texas Instruments Incorporated