

2.5-V 460-kbps RS-232 TRANSCEIVER WITH ± 15 -kV ESD PROTECTION

Check for Samples: [MAX3318](#)

FEATURES

- **ESD Protection for RS-232 I/O Pins**
 - ± 15 kV (Human-Body Model)
 - ± 8 kV (IEC 61000-4-2, Contact Discharge)
 - ± 8 kV (IEC 61000-4-2, Air-Gap Discharge)
- **300- μ A Operating Supply Current**
- **1- μ A Low-Power Standby (With Receivers Active) Mode**
- **Designed to Transmit at a Data Rate of 460 kbps**
- **Auto-Power-Down Plus Option Features Flexible Power-Saving Mode**
- **Operates From a Single 2.25-V to 3-V V_{CC} Supply**

APPLICATIONS

- **Battery-Powered Systems**
- **PDA's**
- **Cellular Phones**
- **Notebooks**
- **Hand-Held Equipment**
- **Pagers**

DESCRIPTION

The MAX3318 is a dual-driver, dual-receiver, RS-232 compatible transceiver. The device features auto-power-down plus and enhanced electrostatic discharge (ESD) protection integrated into the chip. Driver output and receiver input are protected to ± 8 kV using the IEC 61000-4-2 Air-Gap Discharge method, ± 8 kV using the IEC 61000-4-2 Contact Discharge method, and ± 15 kV using the Human-Body Model (HBM).

The device operates at a data rate of 460 kbps. The transceiver has a proprietary low-dropout driver output stage enabling RS-232-compatible operation from a 2.25-V to 3-V supply with a dual charge pump. The charge pump requires only four 0.1- μ F capacitors and features a logic-level output (READY) that asserts when the charge pump is regulating and the device is ready to begin transmitting.

The MAX3318 achieves a 1- μ A supply current using the auto-power-down feature. This device automatically enters a low-power power-down mode when the RS-232 cable is disconnected or the drivers of the connected peripherals are inactive for more than 30 s. The device turns on again when it senses a valid transition at any driver or receiver input. Auto power down saves power without changes to the existing BIOS or operating system.

This device is available in two space-saving packages: 20-pin SSOP and 20-pin TSSOP.

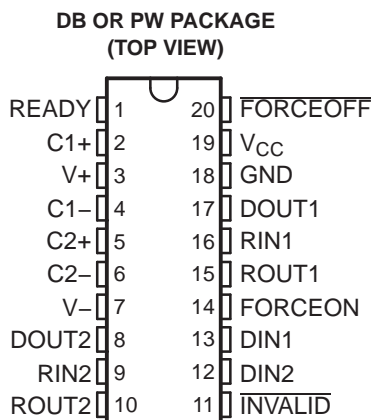

Please be aware that an important notice concerning availability, standard warranty, and use in critical applications of Texas Instruments semiconductor products and disclaimers thereto appears at the end of this data sheet.



This integrated circuit can be damaged by ESD. Texas Instruments recommends that all integrated circuits be handled with appropriate precautions. Failure to observe proper handling and installation procedures can cause damage.

ESD damage can range from subtle performance degradation to complete device failure. Precision integrated circuits may be more susceptible to damage because very small parametric changes could cause the device not to meet its published specifications.

DETAILED DESCRIPTION

Flexible control options for power management are featured when the serial port and driver inputs are inactive. The auto-power-down plus feature functions when FORCEON is low and FORCEOFF is high. During this mode of operation, if the device does not sense valid signal transitions on all receiver and driver inputs for approximately 30 s, the built-in charge pump and drivers are powered down, reducing the supply current to 1 μ A. By disconnecting the serial port or placing the peripheral drivers off, auto-power-down plus can be disabled when FORCEON and FORCEOFF are high. With auto-power-down plus enabled, the device activates automatically when a valid signal is applied to any receiver or driver input. INVALID is high (valid data) if any receiver input voltage is greater than 2.7 V or less than -2.7 V, or has been between -0.3 V and 0.3 V for less than 30 μ s (typical number). INVALID is low (invalid data) if all receiver input voltage are between -0.3 V and 0.3 V for more than 30 μ s (typical number).

FUNCTION TABLE⁽¹⁾

INPUT CONDITIONS				OUTPUT STATES				OPERATING MODE
FORCEON	FORCEOFF	RECEIVER OR DRIVER EDGE WITHIN 30 s	VALID RS-232 LEVEL PRESENT AT RECEIVER	DRIVER	RECEIVER	INVALID	READY	
Auto-Power-Down Plus Conditions								
H	H	No	No	Active	Active	L	H	Normal operation, auto-power-down plus disabled
H	H	No	Yes	Active	Active	H	H	Normal operation, auto-power-down plus disabled
L	H	Yes	No	Active	Active	L	H	Normal operation, auto-power-down plus enabled
L	H	Yes	Yes	Active	Active	H	H	Normal operation, auto-power-down plus enabled
L	H	No	No	Z	Active	L	L	Power down, auto-power-down plus enabled
L	H	No	Yes	Z	Active	H	L	Power down, auto-power-down plus enabled
X	L	X	No	Z	Active	L	L	Manual power down
X	L	X	Yes	Z	Active	H	L	Manual power down
Auto-Power-Down Conditions								
INVALID	INVALID	X	No	Z	Active	L	L	Power down, auto power down enabled
INVALID	INVALID	X	Yes	Active	Active	H	H	Normal operation, auto power down enabled

(1) H = high level, L = low level, X = irrelevant, Z = high impedance

LOGIC DIAGRAM (POSITIVE LOGIC)

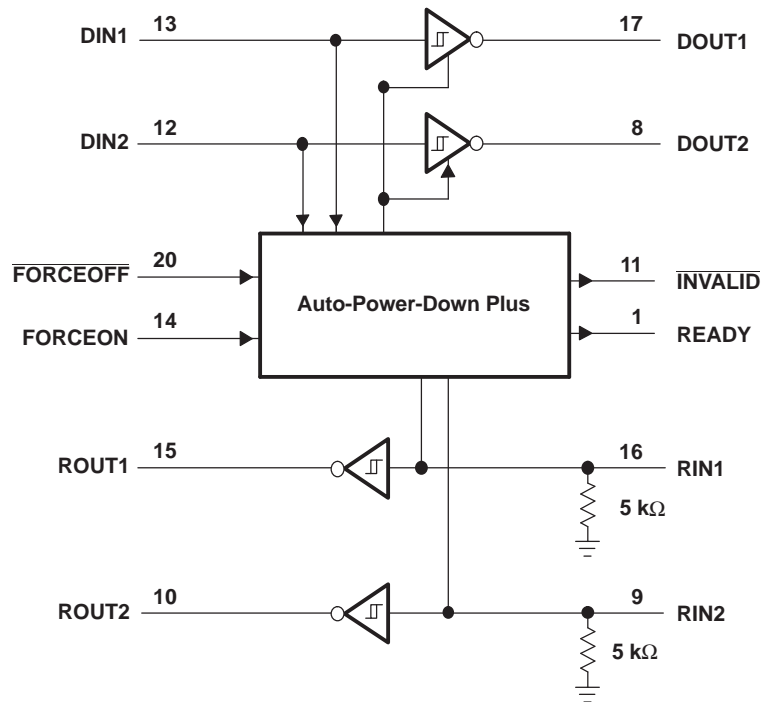

TERMINAL FUNCTIONS

TERMINAL		DESCRIPTION
NAME	NO.	
C1+	2	Positive voltage-doubler charge-pump capacitor
C1–	4	Negative voltage-doubler charge-pump capacitor
C2+	5	Positive inverting charge-pump capacitor
C2–	6	Negative inverting charge-pump capacitor
DIN	12, 13	CMOS driver inputs
DOUT	8, 17	RS-232 driver outputs
$\overline{\text{FORCEOFF}}$	20	Force-off input, active low. Drive low to power down transmitters and charge pump. This overrides auto power down and FORCEON (see Function Table).
FORCEON	14	Force-on input, active high. Drive high to override auto power down, keeping transmitters on ($\overline{\text{FORCEOFF}}$ must be high) (see Function Table).
GND	18	Ground
$\overline{\text{INVALID}}$	11	Valid signal detector output, active low. A logic high indicates that a valid RS-232 level is present on a receiver input.
READY	1	Ready to transmit output, active high. READY is enabled high when V– goes below –3.5 V and the device is ready to transmit.
RIN	9, 16	RS-232 receiver inputs
ROUT	10, 15	CMOS receiver outputs
V+	3	$2 \times V_{CC}$ generated by the charge pump
V–	7	$-2 \times V_{CC}$ generated by the charge pump
V _{CC}	19	2.25-V to 3-V single-supply voltage

Absolute Maximum Ratings⁽¹⁾

over operating free-air temperature range (unless otherwise noted)

		MIN	MAX	UNIT
V _{CC} to GND		-0.3	6	V
V ₊ to GND ⁽²⁾		-0.3	7	V
V ₋ to GND ⁽²⁾		-7	0.3	V
V ₊ + V ₋ ⁽²⁾			13	V
Input voltage	DIN, FORCEON, FORCEOFF to GND	-0.3	6	V
	RIN to GND		±25	
Output voltage	DOUT to GND		±13.2	V
	ROUT, INVALID, READY to GND	-0.3	V _{CC} + 0.3	
Short-circuit duration	DOUT to GND		Continuous	
Continuous power dissipation (T _A = 70°C)	16-pin SSOP (derate 7.14 mW/°C above 70°C)		571	mW
	20-pin SSOP (derate 8 mW/°C above 70°C)		640	
	20-pin TSSOP (derate 7 mW/°C above 70°C)		559	
Storage temperature range		-65	150	°C
Lead temperature (soldering, 10 s)			300	°C

- (1) Stresses beyond those listed under "absolute maximum ratings" may cause permanent damage to the device. These are stress ratings only, and functional operation of the device at these or any other conditions beyond those indicated under "recommended operating conditions" is not implied. Exposure to absolute-maximum-rated conditions for extended periods may affect device reliability.
- (2) V₊ and V₋ can have maximum magnitudes of 7 V, but their absolute difference cannot exceed 13 V.

Recommended Operating Conditions

See Figure 4

		MIN	NOM	MAX	UNIT	
Supply voltage		2.25	2.5	3	V	
V _{IH}	Driver and control high-level input voltage	DIN, FORCEOFF, FORCEON V _{CC} = 2.5 V to 3 V		0.7 × V _{CC}	5.5	V
V _{IL}	Driver and control low-level input voltage	DIN, FORCEOFF, FORCEON V _{CC} = 2.5 V to 3 V		0	0.3 × V _{CC}	V
V _I	Receiver input voltage	-25		25	V	
T _A	Operating free-air temperature	MAX3318C		0	70	°C
		MAX3318I		-40	85	

Supply Current Section Electrical Characteristics

$V_{CC} = 2.25\text{ V to }3\text{ V}$, $C1-C4 = 0.1\ \mu\text{F}$, $T_A = T_{MIN}$ to T_{MAX} (unless otherwise noted)

PARAMETER	TEST CONDITIONS	MIN	TYP ⁽¹⁾	MAX	UNIT
DC Characteristics ($V_{CC} = 2.5\text{ V}$, $T_A = 25^\circ\text{C}$)					
Auto-power-down plus supply current	FORCEON = GND, $\overline{\text{FORCEOFF}} = V_{CC}$, All RIN and DIN idle		1	10	μA
Auto-power-down supply current	$\overline{\text{FORCEOFF}} = \text{GND}$		1	10	μA
Supply current	FORCEON = $\overline{\text{FORCEOFF}} = V_{CC}$, No load		0.3	2	mA

(1) Typical values are at $V_{CC} = 2.5\text{ V}$, $T_A = 25^\circ\text{C}$.

ESD Protection

PARAMETER	TEST CONDITIONS	TYP	UNIT
RIN, DOUT	Human-Body Model (HBM)	± 15	kV
	IEC 61000-4-2 Air-Gap Discharge method	± 8	
	IEC 61000-4-2 Contact Discharge method	± 8	

Driver Section Electrical Characteristics

over recommended ranges of supply voltage and operating free-air temperature,

$V_{CC} = 2.25\text{ V to }3\text{ V}$, $C1-C4 = 0.1\ \mu\text{F}$, $T_A = T_{MIN}$ to T_{MAX} (unless otherwise noted) (see [Figure 4](#))

PARAMETER	TEST CONDITIONS	MIN	TYP ⁽¹⁾	MAX	UNIT
Driver input hysteresis			0.3		V
Input leakage current	FORCEON, DIN, $\overline{\text{FORCEOFF}}$		± 0.01	± 1	μA
Output voltage swing	All driver outputs loaded with $3\text{ k}\Omega$ to ground	± 3.7	± 4		V
Output resistance	$V_{CC} = 0$, Driver output = $\pm 2\text{ V}$	300	10M		Ω
Output short-circuit current ⁽²⁾			± 25	± 60	mA
Output leakage current	$V_{CC} = 0$ or $2.25\text{ V to }3\text{ V}$, $V_{OUT} = \pm 12\text{ V}$, Drivers disabled			± 25	μA

(1) Typical values are at $V_{CC} = 2.5\text{ V}$, $T_A = 25^\circ\text{C}$.

(2) Short-circuit durations should be controlled to prevent exceeding the device absolute power dissipation ratings, and not more than one output should be shorted at a time.

Driver Section Switching Characteristics

over recommended ranges of supply voltage and operating free-air temperature,

$V_{CC} = 2.25\text{ V to }3\text{ V}$, $C1-C4 = 0.1\ \mu\text{F}$, $T_A = T_{MIN}$ to T_{MAX} (unless otherwise noted) (see [Figure 1](#))

PARAMETER	TEST CONDITIONS	MIN	TYP ⁽¹⁾	MAX	UNIT
Maximum data rate	$R_L = 3\text{ k}\Omega$, $C_L = 1000\text{ pF}$, One transmitter switching	460			kbps
$ t_{PHL} - t_{PLH} $ Driver skew ⁽²⁾			100		ns
Transition-region slew rate	$V_{CC} = 2.5\text{ V}$, $T_A = 25^\circ\text{C}$, $R_L = 3\text{ k}\Omega$ to $7\text{ k}\Omega$, Measured from $3\text{ V to }-3\text{ V}$ or $-3\text{ V to }3\text{ V}$, $C_L = 150\text{ pF to }2500\text{ pF}$	4		30	V/ μs

(1) Typical values are at $V_{CC} = 2.5\text{ V}$, $T_A = 25^\circ\text{C}$.

(2) Pulse skew is defined as $|t_{PLH} - t_{PHL}|$ of each channel of the same device.

Receiver Section Electrical Characteristics

over recommended ranges of supply voltage and operating free-air temperature,
 $V_{CC} = 2.25\text{ V to }3\text{ V}$, $C1-C4 = 0.1\ \mu\text{F}$, $T_A = T_{MIN}$ to T_{MAX} (unless otherwise noted) (see Figure 4)

PARAMETER	TEST CONDITIONS	MIN	TYP ⁽¹⁾	MAX	UNIT
Input voltage range		-25		25	V
Input threshold low	$T_A = 25^\circ\text{C}$			$0.3 \times V_{CC}$	V
Input threshold high	$T_A = 25^\circ\text{C}$	$0.7 \times V_{CC}$			V
Input hysteresis			0.3		V
Input resistance	$T_A = 25^\circ\text{C}$	3	5	7	k Ω
Output leakage current			± 0.05	± 10	μA
Output voltage low	$I_{OUT} = 0.5\text{ mA}$			$0.1 \times V_{CC}$	V
Output voltage high	$I_{OUT} = -0.5\text{ mA}$	$0.9 \times V_{CC}$			V

(1) Typical values are at $V_{CC} = 2.5\text{ V}$, $T_A = 25^\circ\text{C}$.

Receiver Section Switching Characteristics

over recommended ranges of supply voltage and operating free-air temperature,
 $V_{CC} = 2.25\text{ V to }3\text{ V}$, $C1-C4 = 0.1\ \mu\text{F}$, $T_A = T_{MIN}$ to T_{MAX} (unless otherwise noted) (see Figure 4)

PARAMETER	TEST CONDITIONS	TYP ⁽¹⁾	UNIT
t_{PHL}	Receiver propagation delay RIN to ROUT, $C_L = 150\text{ pF}$	0.175	μs
t_{PLH}		0.175	
$ t_{PHL} - t_{PLH} $	Receiver skew ⁽²⁾	50	ns

(1) Typical values are at $V_{CC} = 2.5\text{ V}$, $T_A = 25^\circ\text{C}$.

(2) Pulse skew is defined as $|t_{PLH} - t_{PHL}|$ of each channel of the same device.

Auto-Power-Down Plus Section Electrical Characteristics

over recommended ranges of supply voltage and operating free-air temperature,
 $V_{CC} = 2.25\text{ V to }3\text{ V}$, $C1-C4 = 0.1\ \mu\text{F}$, $T_A = T_{MIN}$ to T_{MAX} (unless otherwise noted) (see Figure 4)

PARAMETER	TEST CONDITIONS	MIN	MAX	UNIT
Receiver input threshold to $\overline{\text{INVALID}}$ high	Positive threshold		2.7	V
	Negative threshold	-2.7		
Receiver input threshold $\overline{\text{INVALID}}$ low		-0.3	0.3	V
$\overline{\text{INVALID}}$, READY voltage low	$I_{OUT} = 0.5\text{ mA}$		$0.1 \times V_{CC}$	V
$\overline{\text{INVALID}}$, READY voltage high	$I_{OUT} = -0.5\text{ mA}$	$0.8 \times V_{CC}$		V

Auto-Power-Down Plus Section Switching Characteristics

over recommended ranges of supply voltage and operating free-air temperature,
 $V_{CC} = 2.25\text{ V to }3\text{ V}$, $C1-C4 = 0.1\ \mu\text{F}$, $T_A = T_{MIN}$ to T_{MAX} (unless otherwise noted) (see Figure 4)

PARAMETER	TEST CONDITIONS	MIN	TYP ⁽¹⁾	MAX	UNIT
t_{INVH}	Receiver positive or negative threshold to $\overline{\text{INVALID}}$ high $V_{CC} = 2.5\text{ V}$		1		μs
t_{INVL}	Receiver positive or negative threshold to $\overline{\text{INVALID}}$ low $V_{CC} = 2.5\text{ V}$		30		μs
t_{WU}	Receiver or driver edge to driver enabled $V_{CC} = 2.5\text{ V}$		100		μs
$t_{AUTOPRDN}$	Receiver or driver edge to driver shutdown $V_{CC} = 2.5\text{ V}$	15	30	60	s

(1) Typical values are at $V_{CC} = 2.5\text{ V}$, $T_A = 25^\circ\text{C}$.

PARAMETER MEASUREMENT INFORMATION

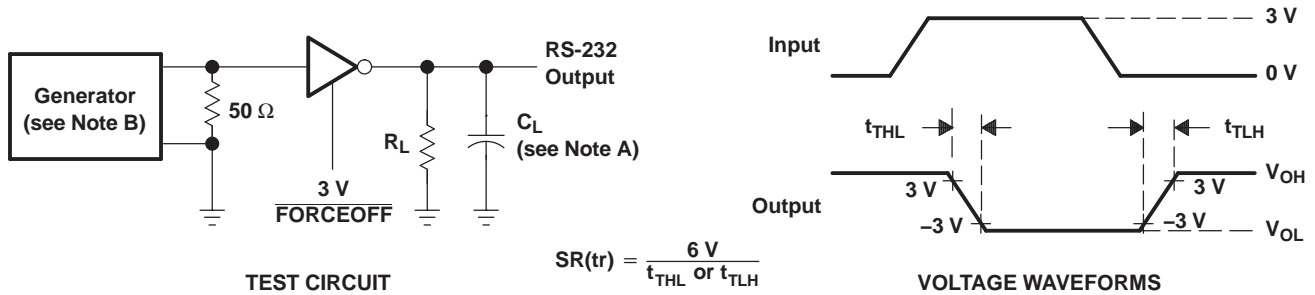

NOTES: A. C_L includes probe and jig capacitance.
 B. The pulse generator has the following characteristics: PRR = 250 kbit/s, $Z_O = 50\ \Omega$, 50% duty cycle, $t_r \leq 10\text{ ns}$, $t_f \leq 10\text{ ns}$.

Figure 1. Driver Slew Rate

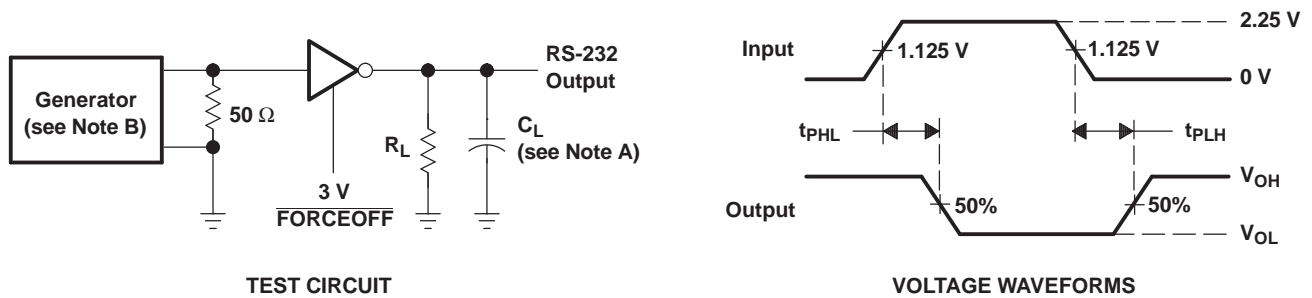

NOTES: A. C_L includes probe and jig capacitance.
 B. The pulse generator has the following characteristics: PRR = 250 kbit/s, $Z_O = 50\ \Omega$, 50% duty cycle, $t_r \leq 10\text{ ns}$, $t_f \leq 10\text{ ns}$.

Figure 2. Driver Pulse Skew

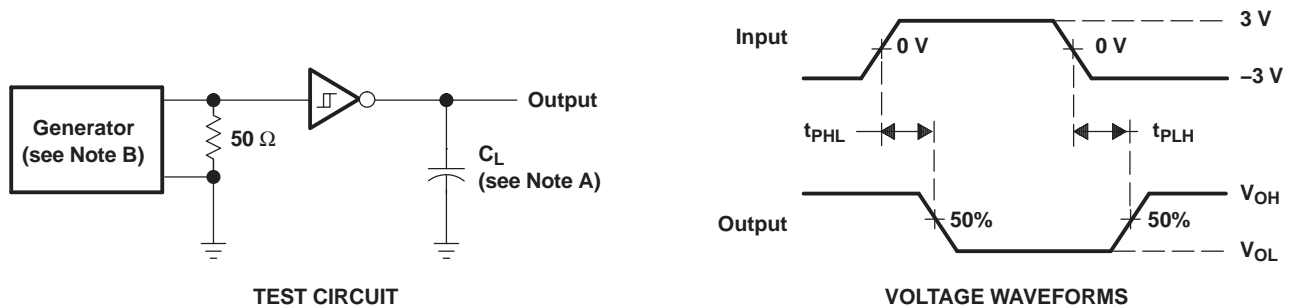

NOTES: A. C_L includes probe and jig capacitance.
 B. The pulse generator has the following characteristics: $Z_O = 50\ \Omega$, 50% duty cycle, $t_r \leq 10\text{ ns}$, $t_f \leq 10\text{ ns}$.

Figure 3. Receiver Propagation Delay Times

PARAMETER MEASUREMENT INFORMATION

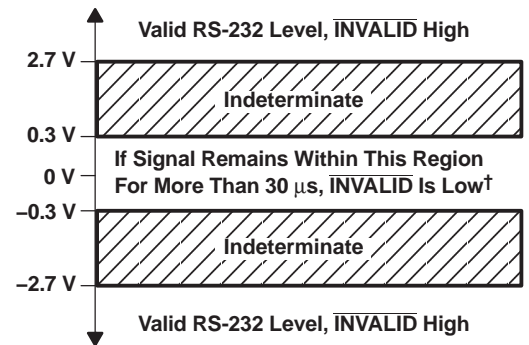
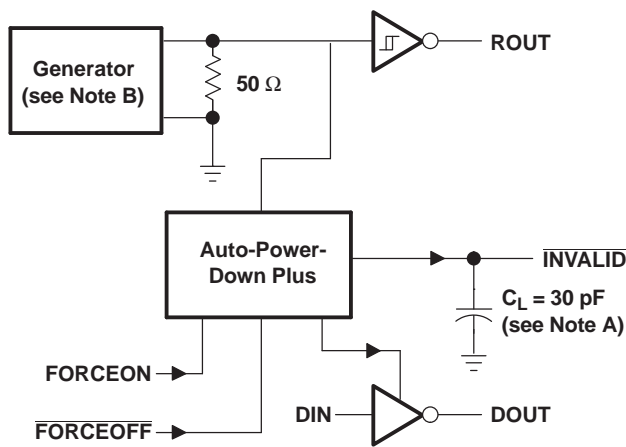
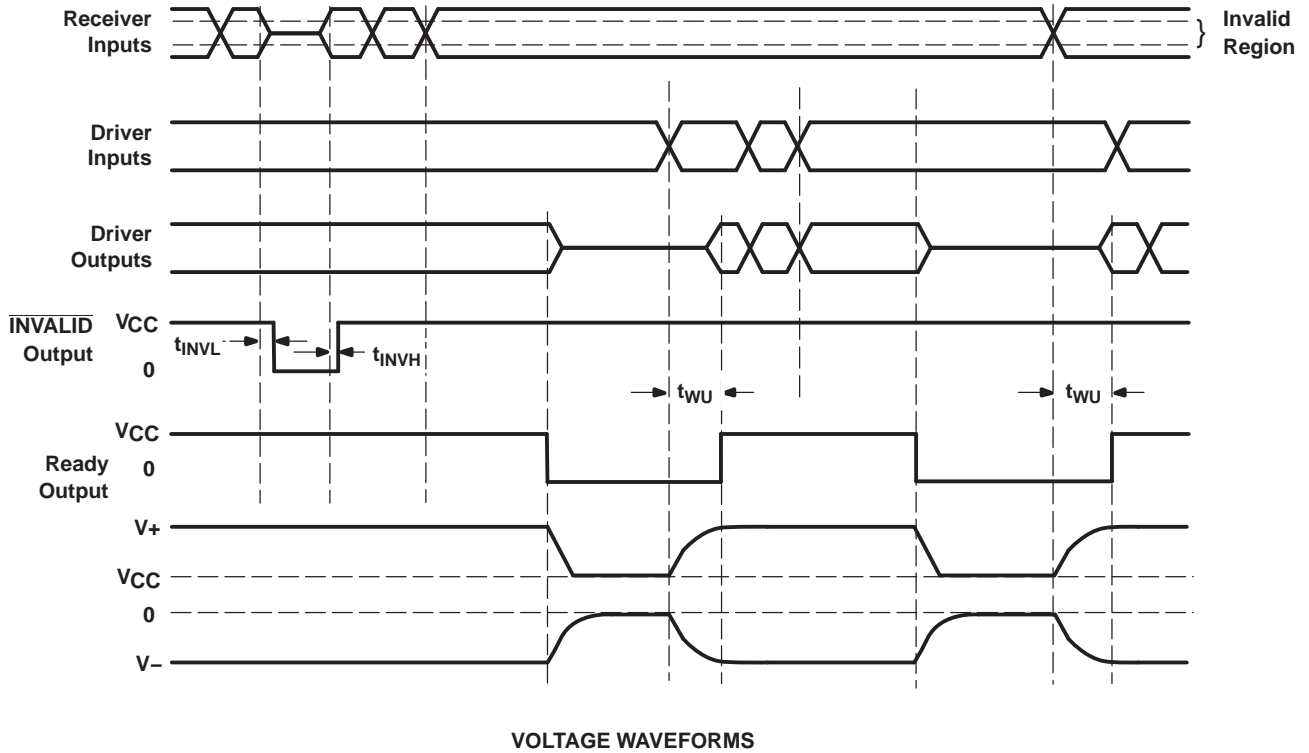

† Auto power down disables drivers and reduces supply current to 1 μA.

TEST CIRCUIT

Figure 4. INVALID Propagation Delay Times and Supply Enabling Time

PARAMETER MEASUREMENT INFORMATION

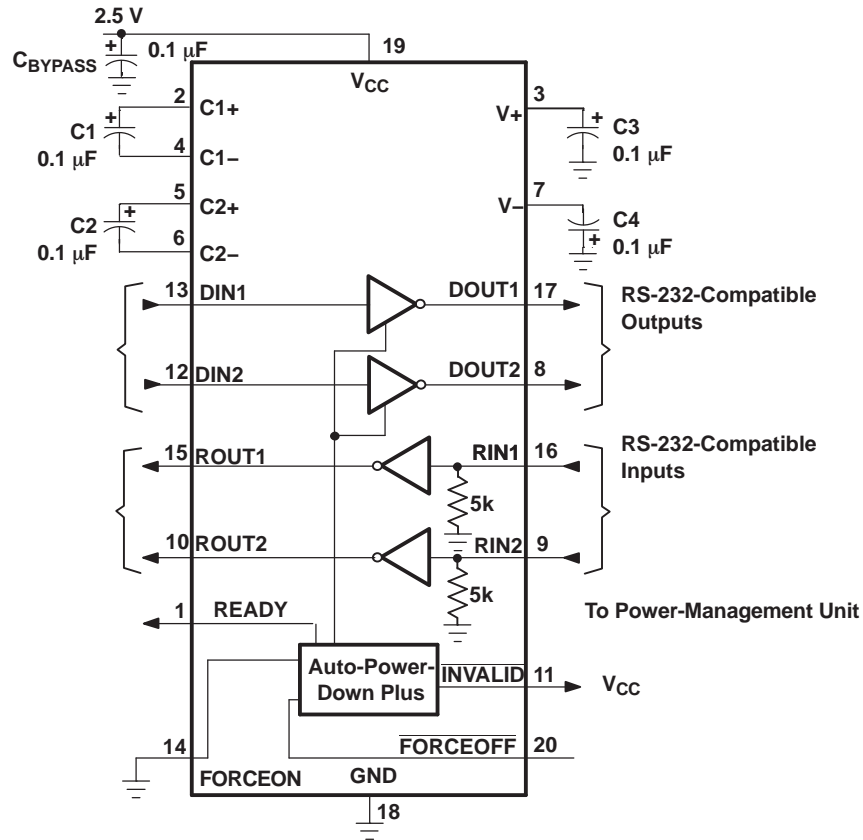

Figure 5. Typical Application Circuit

REVISION HISTORY

Changes from Original (June 2006) to Revision A	Page
• Updated document to new TI datasheet format - no specification changes.	1
• Removed Ordering Information Table.	2
• Updated TERMINAL FUNCTIONS table to fix inconsistency.	3

PACKAGING INFORMATION

Orderable Device	Status (1)	Package Type	Package Drawing	Pins	Package Qty	Eco Plan (2)	Lead finish/ Ball material (6)	MSL Peak Temp (3)	Op Temp (°C)	Device Marking (4/5)	Samples
MAX3318CDBR	ACTIVE	SSOP	DB	20	2000	RoHS & Green	NIPDAU	Level-1-260C-UNLIM	0 to 70	MP318C	Samples
MAX3318CPW	ACTIVE	TSSOP	PW	20	70	RoHS & Green	NIPDAU	Level-1-260C-UNLIM	0 to 70	MP318C	Samples
MAX3318CPWR	ACTIVE	TSSOP	PW	20	2000	RoHS & Green	NIPDAU	Level-1-260C-UNLIM	0 to 70	MP318C	Samples
MAX3318IDBR	ACTIVE	SSOP	DB	20	2000	RoHS & Green	NIPDAU	Level-1-260C-UNLIM	-40 to 85	MP318I	Samples
MAX3318IPWR	ACTIVE	TSSOP	PW	20	2000	RoHS & Green	NIPDAU	Level-1-260C-UNLIM	-40 to 85	MP318I	Samples

(1) The marketing status values are defined as follows:

ACTIVE: Product device recommended for new designs.

LIFEBUY: TI has announced that the device will be discontinued, and a lifetime-buy period is in effect.

NRND: Not recommended for new designs. Device is in production to support existing customers, but TI does not recommend using this part in a new design.

PREVIEW: Device has been announced but is not in production. Samples may or may not be available.

OBSELETE: TI has discontinued the production of the device.

(2) **RoHS:** TI defines "RoHS" to mean semiconductor products that are compliant with the current EU RoHS requirements for all 10 RoHS substances, including the requirement that RoHS substance do not exceed 0.1% by weight in homogeneous materials. Where designed to be soldered at high temperatures, "RoHS" products are suitable for use in specified lead-free processes. TI may reference these types of products as "Pb-Free".

RoHS Exempt: TI defines "RoHS Exempt" to mean products that contain lead but are compliant with EU RoHS pursuant to a specific EU RoHS exemption.

Green: TI defines "Green" to mean the content of Chlorine (Cl) and Bromine (Br) based flame retardants meet JS709B low halogen requirements of <=1000ppm threshold. Antimony trioxide based flame retardants must also meet the <=1000ppm threshold requirement.

(3) MSL, Peak Temp. - The Moisture Sensitivity Level rating according to the JEDEC industry standard classifications, and peak solder temperature.

(4) There may be additional marking, which relates to the logo, the lot trace code information, or the environmental category on the device.

(5) Multiple Device Markings will be inside parentheses. Only one Device Marking contained in parentheses and separated by a "~" will appear on a device. If a line is indented then it is a continuation of the previous line and the two combined represent the entire Device Marking for that device.

(6) Lead finish/Ball material - Orderable Devices may have multiple material finish options. Finish options are separated by a vertical ruled line. Lead finish/Ball material values may wrap to two lines if the finish value exceeds the maximum column width.

Important Information and Disclaimer: The information provided on this page represents TI's knowledge and belief as of the date that it is provided. TI bases its knowledge and belief on information provided by third parties, and makes no representation or warranty as to the accuracy of such information. Efforts are underway to better integrate information from third parties. TI has taken and continues to take reasonable steps to provide representative and accurate information but may not have conducted destructive testing or chemical analysis on incoming materials and chemicals. TI and TI suppliers consider certain information to be proprietary, and thus CAS numbers and other limited information may not be available for release.

In no event shall TI's liability arising out of such information exceed the total purchase price of the TI part(s) at issue in this document sold by TI to Customer on an annual basis.

TAPE AND REEL INFORMATION

QUADRANT ASSIGNMENTS FOR PIN 1 ORIENTATION IN TAPE

*All dimensions are nominal

Device	Package Type	Package Drawing	Pins	SPQ	Reel Diameter (mm)	Reel Width W1 (mm)	A0 (mm)	B0 (mm)	K0 (mm)	P1 (mm)	W (mm)	Pin1 Quadrant
MAX3318CDBR	SSOP	DB	20	2000	330.0	16.4	8.2	7.5	2.5	12.0	16.0	Q1
MAX3318CPWR	TSSOP	PW	20	2000	330.0	16.4	6.95	7.0	1.4	8.0	16.0	Q1
MAX3318IDBR	SSOP	DB	20	2000	330.0	16.4	8.2	7.5	2.5	12.0	16.0	Q1
MAX3318IPWR	TSSOP	PW	20	2000	330.0	16.4	6.95	7.0	1.4	8.0	16.0	Q1

TAPE AND REEL BOX DIMENSIONS

*All dimensions are nominal

Device	Package Type	Package Drawing	Pins	SPQ	Length (mm)	Width (mm)	Height (mm)
MAX3318CDBR	SSOP	DB	20	2000	356.0	356.0	35.0
MAX3318CPWR	TSSOP	PW	20	2000	356.0	356.0	35.0
MAX3318IDBR	SSOP	DB	20	2000	356.0	356.0	35.0
MAX3318IPWR	TSSOP	PW	20	2000	356.0	356.0	35.0

TUBE

*All dimensions are nominal

Device	Package Name	Package Type	Pins	SPQ	L (mm)	W (mm)	T (μm)	B (mm)
MAX3318CPW	PW	TSSOP	20	70	530	10.2	3600	3.5



4220206/A 02/2017

NOTES:

1. All linear dimensions are in millimeters. Any dimensions in parenthesis are for reference only. Dimensioning and tolerancing per ASME Y14.5M.
2. This drawing is subject to change without notice.
3. This dimension does not include mold flash, protrusions, or gate burrs. Mold flash, protrusions, or gate burrs shall not exceed 0.15 mm per side.
4. This dimension does not include interlead flash. Interlead flash shall not exceed 0.25 mm per side.
5. Reference JEDEC registration MO-153.

EXAMPLE BOARD LAYOUT

PW0020A

TSSOP - 1.2 mm max height

SMALL OUTLINE PACKAGE



LAND PATTERN EXAMPLE
EXPOSED METAL SHOWN
SCALE: 10X



SOLDER MASK DETAILS

4220206/A 02/2017

NOTES: (continued)

- 6. Publication IPC-7351 may have alternate designs.
- 7. Solder mask tolerances between and around signal pads can vary based on board fabrication site.

EXAMPLE STENCIL DESIGN

PW0020A

TSSOP - 1.2 mm max height

SMALL OUTLINE PACKAGE



SOLDER PASTE EXAMPLE
BASED ON 0.125 mm THICK STENCIL
SCALE: 10X

4220206/A 02/2017

NOTES: (continued)

8. Laser cutting apertures with trapezoidal walls and rounded corners may offer better paste release. IPC-7525 may have alternate design recommendations.
9. Board assembly site may have different recommendations for stencil design.

DB0020A



PACKAGE OUTLINE

SSOP - 2 mm max height

SMALL OUTLINE PACKAGE



4214851/B 08/2019

NOTES:

1. All linear dimensions are in millimeters. Any dimensions in parenthesis are for reference only. Dimensioning and tolerancing per ASME Y14.5M.
2. This drawing is subject to change without notice.
3. This dimension does not include mold flash, protrusions, or gate burrs. Mold flash, protrusions, or gate burrs shall not exceed 0.15 mm per side.
4. This dimension does not include interlead flash. Interlead flash shall not exceed 0.25 mm per side.
5. Reference JEDEC registration MO-150.

EXAMPLE BOARD LAYOUT

DB0020A

SSOP - 2 mm max height

SMALL OUTLINE PACKAGE



LAND PATTERN EXAMPLE
EXPOSED METAL SHOWN
SCALE: 10X



4214851/B 08/2019

NOTES: (continued)

- 6. Publication IPC-7351 may have alternate designs.
- 7. Solder mask tolerances between and around signal pads can vary based on board fabrication site.

EXAMPLE STENCIL DESIGN

DB0020A

SSOP - 2 mm max height

SMALL OUTLINE PACKAGE



SOLDER PASTE EXAMPLE
BASED ON 0.125 mm THICK STENCIL
SCALE: 10X

4214851/B 08/2019

NOTES: (continued)

8. Laser cutting apertures with trapezoidal walls and rounded corners may offer better paste release. IPC-7525 may have alternate design recommendations.
9. Board assembly site may have different recommendations for stencil design.

IMPORTANT NOTICE AND DISCLAIMER

TI PROVIDES TECHNICAL AND RELIABILITY DATA (INCLUDING DATA SHEETS), DESIGN RESOURCES (INCLUDING REFERENCE DESIGNS), APPLICATION OR OTHER DESIGN ADVICE, WEB TOOLS, SAFETY INFORMATION, AND OTHER RESOURCES "AS IS" AND WITH ALL FAULTS, AND DISCLAIMS ALL WARRANTIES, EXPRESS AND IMPLIED, INCLUDING WITHOUT LIMITATION ANY IMPLIED WARRANTIES OF MERCHANTABILITY, FITNESS FOR A PARTICULAR PURPOSE OR NON-INFRINGEMENT OF THIRD PARTY INTELLECTUAL PROPERTY RIGHTS.

These resources are intended for skilled developers designing with TI products. You are solely responsible for (1) selecting the appropriate TI products for your application, (2) designing, validating and testing your application, and (3) ensuring your application meets applicable standards, and any other safety, security, regulatory or other requirements.

These resources are subject to change without notice. TI grants you permission to use these resources only for development of an application that uses the TI products described in the resource. Other reproduction and display of these resources is prohibited. No license is granted to any other TI intellectual property right or to any third party intellectual property right. TI disclaims responsibility for, and you will fully indemnify TI and its representatives against, any claims, damages, costs, losses, and liabilities arising out of your use of these resources.

TI's products are provided subject to [TI's Terms of Sale](#) or other applicable terms available either on [ti.com](https://www.ti.com) or provided in conjunction with such TI products. TI's provision of these resources does not expand or otherwise alter TI's applicable warranties or warranty disclaimers for TI products.

TI objects to and rejects any additional or different terms you may have proposed.

Mailing Address: Texas Instruments, Post Office Box 655303, Dallas, Texas 75265
Copyright © 2024, Texas Instruments Incorporated