

Table of Contents

1 Features	1	7.1 Load Circuit and Voltage Waveforms.....	16
2 Applications	1	8 Detailed Description	18
3 Description	1	8.1 Overview.....	18
4 Revision History	2	8.2 Functional Block Diagram.....	18
5 Pin Configuration and Functions	3	8.3 Feature Description.....	18
6 Specifications	4	8.4 Device Functional Modes.....	20
6.1 Absolute Maximum Ratings.....	4	9 Application and Implementation	21
6.2 ESD Ratings.....	4	9.1 Application Information.....	21
6.3 Recommended Operating Conditions.....	5	9.2 Typical Applications.....	21
6.4 Thermal Information.....	5	10 Power Supply Recommendations	24
6.5 Electrical Characteristics.....	6	11 Layout	24
6.6 Switching Characteristics, $V_{CCA} = 0.7\text{ V}$	8	11.1 Layout Guidelines.....	24
6.7 Switching Characteristics, $V_{CCA} = 0.8\text{ V}$	8	11.2 Layout Example.....	24
6.8 Switching Characteristics, $V_{CCA} = 0.9\text{ V}$	9	12 Device and Documentation Support	25
6.9 Switching Characteristics, $V_{CCA} = 1.2\text{ V}$	9	12.1 Documentation Support.....	25
6.10 Switching Characteristics, $V_{CCA} = 1.5\text{ V}$	10	12.2 Receiving Notification of Documentation Updates.....	25
6.11 Switching Characteristics, $V_{CCA} = 1.8\text{ V}$	10	12.3 Support Resources.....	25
6.12 Switching Characteristics, $V_{CCA} = 2.5\text{ V}$	11	12.4 Trademarks.....	25
6.13 Switching Characteristics, $V_{CCA} = 3.3\text{ V}$	11	12.5 Electrostatic Discharge Caution.....	25
6.14 Operating Characteristics: $T_A = 25^\circ\text{C}$	12	12.6 Glossary.....	25
6.15 Typical Characteristics.....	13	13 Mechanical, Packaging, and Orderable Information	25
7 Parameter Measurement Information	16		

4 Revision History

NOTE: Page numbers for previous revisions may differ from page numbers in the current version.

Changes from Revision B (June 2020) to Revision C (September 2020)	Page
• Updated I_{CCA} , I_{CCB} , and $I_{CCA} + I_{CCB}$ to reflect updated performance of device.....	6
Changes from Revision A (January 2019) to Revision B (June 2020)	Page
• Added DRY package option to <i>Device Information</i> table.....	1
• Added pinout drawing for DRY package.....	3
Changes from Revision * (December 2018) to Revision A (January 2019)	Page
• Added DBV and DTQ package options to <i>Device Information</i> table.....	1
• Updated <i>Revision History</i> section.....	1
• Added pinout drawings for DBV and DTQ packages.....	3
• Added DRY package to Pin Configurations.....	3

5 Pin Configuration and Functions

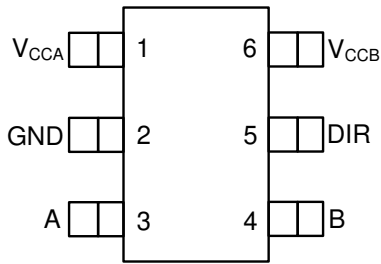

Figure 5-1. DBV Package 6-Pin SOT-23 Top View

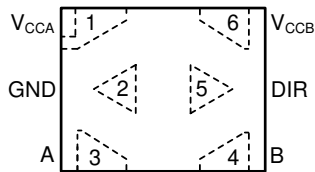

Figure 5-3. DTQ Package 6-Pin X2SON Transparent Top View

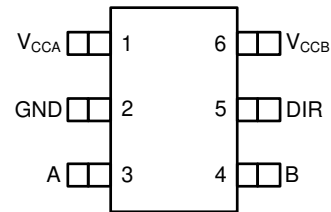

Figure 5-2. DCK Package 6-Pin SC70 Top View

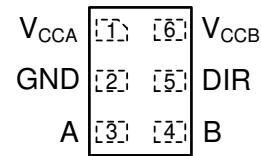

Figure 5-4. DRY Package 6-Pin SON Transparent Top View

Pin Functions

PIN		TYPE	DESCRIPTION
NO.	NAME		
1	V _{CCA}	—	A-port supply voltage. $0.65\text{ V} \leq V_{CCA} \leq 3.6\text{ V}$.
2	GND	—	Ground
3	A	I/O	Input/output A. This pin is referenced to V _{CCA} .
4	B	I/O	Input/output B. This pin is referenced to V _{CCB} .
5	DIR	I	Direction control signal. See for functionality.
6	V _{CCB}	—	B-port supply voltage. $0.65\text{ V} \leq V_{CCB} \leq 3.6\text{ V}$.

6 Specifications

6.1 Absolute Maximum Ratings

over operating free-air temperature range (unless otherwise noted)⁽¹⁾

			MIN	MAX	UNIT
V _{CCA}	Supply voltage A		-0.5	4.2	V
V _{CCB}	Supply voltage B		-0.5	4.2	V
V _I	Input Voltage ⁽²⁾	I/O Ports (A Port)	-0.5	4.2	V
		I/O Ports (B Port)	-0.5	4.2	
		Control Inputs	-0.5	4.2	
V _O	Voltage applied to any output in the high-impedance or power-off state ⁽²⁾	A Port	-0.5	4.2	V
		B Port	-0.5	4.2	
V _O	Voltage applied to any output in the high or low state ^{(2) (3)}	A Port	-0.5 V _{CCA} + 0.2		V
		B Port	-0.5 V _{CCB} + 0.2		
I _{IK}	Input clamp current	V _I < 0	-50		mA
I _{OK}	Output clamp current	V _O < 0	-50		mA
I _O	Continuous output current		-50	50	mA
	Continuous current through V _{CC} or GND		-100	100	mA
T _J	Junction Temperature			150	°C
T _{stg}	Storage temperature		-65	150	°C

- (1) Stresses beyond those listed under *Absolute Maximum Ratings* may cause permanent damage to the device. These are stress ratings only, which do not imply functional operation of the device at these or any other conditions beyond those indicated under *Recommended Operating Conditions*. Exposure to absolute-maximum-rated conditions for extended periods may affect device reliability.
- (2) The input voltage and output negative-voltage ratings may be exceeded if the input and output current ratings are observed.
- (3) The output positive-voltage rating may be exceeded up to 4.2 V maximum if the output current rating is observed.

6.2 ESD Ratings

			VALUE	UNIT
V _(ESD)	Electrostatic discharge	Human body model (HBM), per ANSI/ESDA/JEDEC JS-001 ⁽¹⁾	±8000	V
		Charged device model (CDM), per JEDEC specification JESD22-C101 ⁽²⁾	±1000	

- (1) JEDEC document JEP155 states that 500-V HBM allows safe manufacturing with a standard ESD control process.
- (2) JEDEC document JEP157 states that 250-V CDM allows safe manufacturing with a standard ESD control process.

6.3 Recommended Operating Conditions

over operating free-air temperature range (unless otherwise noted)⁽¹⁾ ⁽²⁾ ⁽³⁾

			MIN	MAX	UNIT
V _{CCA}	Supply voltage A		0.65	3.6	V
V _{CCB}	Supply voltage B		0.65	3.6	V
V _{IH}	High-level input voltage	Data Inputs	V _{CCI} = 0.65 V - 0.75 V	V _{CCI} × 0.70	V
			V _{CCI} = 0.76 V - 1 V	V _{CCI} × 0.70	
			V _{CCI} = 1.1 V - 1.95 V	V _{CCI} × 0.65	
			V _{CCI} = 2.3 V - 2.7 V	1.6	
			V _{CCI} = 3 V - 3.6 V	2	
		Control Input (DIR) Referenced to V _{CCA}	V _{CCA} = 0.65 V - 0.75 V	V _{CCA} × 0.70	
			V _{CCA} = 0.76 V - 1 V	V _{CCA} × 0.70	
			V _{CCA} = 1.1 V - 1.95 V	V _{CCA} × 0.65	
			V _{CCA} = 2.3 V - 2.7 V	1.6	
			V _{CCA} = 3 V - 3.6 V	2	
V _{IL}	Low-level input voltage	Data Inputs	V _{CCI} = 0.65 V - 0.75 V	V _{CCI} × 0.30	V
			V _{CCI} = 0.76 V - 1 V	V _{CCI} × 0.30	
			V _{CCI} = 1.1 V - 1.95 V	V _{CCI} × 0.35	
			V _{CCI} = 2.3 V - 2.7 V	0.7	
			V _{CCI} = 3 V - 3.6 V	0.8	
		Control Input (DIR) Referenced to V _{CCA}	V _{CCA} = 0.65 V - 0.75 V	V _{CCA} × 0.30	
			V _{CCA} = 0.76 V - 1 V	V _{CCA} × 0.30	
			V _{CCA} = 1.1 V - 1.95 V	V _{CCA} × 0.35	
			V _{CCA} = 2.3 V - 2.7 V	0.7	
			V _{CCA} = 3 V - 3.6 V	0.8	
V _I	Input voltage ⁽³⁾		0	3.6	V
V _O	Output voltage	Active State	0	V _{CCO}	V
		Tri-State	0	3.6	
Δt/Δv	Input transition rate			100	ns/V
T _A	Operating free-air temperature		-40	125	°C

(1) V_{CCI} is the VCC associated with the input port.

(2) V_{CCO} is the VCC associated with the output port.

(3) All unused inputs of the device must be held at VCC or GND to ensure proper device operation. Refer to the TI application report, [Implications of Slow or Floating CMOS Inputs](#).

6.4 Thermal Information

THERMAL METRIC ⁽¹⁾	SN74AXCH1T45				UNIT	
	DBV (SOT-23)	DCK (SC70)	DTQ (X2SON)	DRY (SON)		
	6 PINS	6 PINS	6 PINS	6 PINS		
R _{θJA}	Junction-to-ambient thermal resistance	214.0	223.9	327.8	308.3	°C/W
R _{θJC(top)}	Junction-to-case (top) thermal resistance	151.8	150.9	194.9	206.4	°C/W
R _{θJB}	Junction-to-board thermal resistance	93.6	75.3	248.4	181.7	°C/W
ψ _{JT}	Junction-to-top characterization parameter	78.1	58.2	24.1	42.6	°C/W
ψ _{JB}	Junction-to-board characterization parameter	93.4	75.0	247.6	180.8	°C/W

(1) For more information about traditional and new thermal metrics, see the *Semiconductor and IC Package Thermal Metrics* application report, [SPRA953](#).

6.5 Electrical Characteristics

over operating free-air temperature range (unless otherwise noted) ⁽¹⁾ ⁽²⁾

PARAMETER	TEST CONDITIONS	V _{CCA}	V _{CCB}	Operating free-air temperature (T _A)						UNIT	
				–40°C to 85°C			–40°C to 125°C				
				MIN	TYP ⁽³⁾	MAX	MIN	TYP	MAX		
V _{OH}	High-level output voltage V _I = V _{IH}	0.7 V - 3.6 V	0.7 V - 3.6 V	V _{CCO} – 0.1			V _{CCO} – 0.1			V	
				I _{OH} = –100 μA	0.65 V	0.65 V	0.55	0.55			
				I _{OH} = –200 μA	0.76 V	0.76 V	0.58	0.58			
				I _{OH} = –500 μA	0.85 V	0.85 V	0.65	0.65			
				I _{OH} = –3 mA	1.1 V	1.1 V	0.85	0.85			
				I _{OH} = –6 mA	1.4 V	1.4 V	1.05	1.05			
				I _{OH} = –8 mA	1.65 V	1.65 V	1.2	1.2			
				I _{OH} = –9 mA	2.3 V	2.3 V	1.75	1.75			
				I _{OH} = –12 mA	3 V	3 V	2.3	2.3			
V _{OL}	Low-level output voltage V _I = V _{IL}	0.7 V - 3.6 V	0.7 V - 3.6 V				0.1			V	
				I _{OL} = 100 μA	0.65 V	0.65 V	0.1	0.1			
				I _{OL} = 200 μA	0.76 V	0.76 V	0.18	0.18			
				I _{OL} = 500 μA	0.85 V	0.85 V	0.2	0.2			
				I _{OL} = 3 mA	1.1 V	1.1 V	0.25	0.25			
				I _{OL} = 6 mA	1.4 V	1.4 V	0.35	0.35			
				I _{OL} = 8 mA	1.65 V	1.65 V	0.45	0.45			
				I _{OL} = 9 mA	2.3 V	2.3 V	0.55	0.55			
				I _{OL} = 12 mA	3 V	3 V	0.7	0.7			
I _{BHL}	Bus-hold low sustaining current ⁽⁴⁾	V _I = 0.20 V	0.65 V	0.65 V	4			4			μA
					V _I = 0.23 V	0.76 V	0.76 V	8	7		
					V _I = 0.26 V	0.85 V	0.85 V	10	10		
					V _I = 0.39 V	1.1 V	1.1 V	20	20		
					V _I = 0.49 V	1.4 V	1.4 V	40	30		
					V _I = 0.58 V	1.65 V	1.65 V	55	45		
					V _I = 0.7 V	2.3 V	2.3 V	90	80		
					V _I = 0.8 V	3 V	3 V	145	135		
I _{BHH}	Bus-hold high sustaining current ⁽⁵⁾	V _I = 0.45 V	0.65 V	0.65 V	–4			–4			μA
					V _I = 0.53 V	0.76 V	0.76 V	–8	–7		
					V _I = 0.59 V	0.85 V	0.85 V	–10	–10		
					V _I = 0.71 V	1.1 V	1.1 V	–20	–20		
					V _I = 0.91 V	1.4 V	1.4 V	–40	–30		
					V _I = 1.07 V	1.65 V	1.65 V	–55	–45		
					V _I = 1.6 V	2.3 V	2.3 V	–90	–80		
					V _I = 2.0 V	3 V	3 V	–145	–135		

6.5 Electrical Characteristics (continued)

over operating free-air temperature range (unless otherwise noted) ⁽¹⁾ ⁽²⁾

PARAMETER	TEST CONDITIONS	V _{CCA}	V _{CCB}	Operating free-air temperature (T _A)						UNIT	
				–40°C to 85°C			–40°C to 125°C				
				MIN	TYP ⁽³⁾	MAX	MIN	TYP	MAX		
I _{BHLO}	Bus-hold low overdrive current ⁽⁶⁾	V _I = 0 to V _{CC}	0.75 V	0.75 V	40			40			μA
			0.84 V	0.84 V	50			50			
			0.95 V	0.95 V	65			65			
			1.3 V	1.3 V	105			105			
			1.6 V	1.6 V	150			150			
			1.95 V	1.95 V	205			205			
			2.7 V	2.7 V	335			335			
3.6 V	3.6 V	480			480						
I _{BHHO}	Bus-hold high overdrive current ⁽⁷⁾	V _I = 0 to V _{CC}	0.75 V	0.75 V	–40			–40			μA
			0.84 V	0.84 V	–50			–50			
			0.95 V	0.95 V	–65			–65			
			1.3 V	1.3 V	–105			–105			
			1.6 V	1.6 V	–150			–150			
			1.95 V	1.95 V	–205			–205			
			2.7 V	2.7 V	–335			–335			
3.6 V	3.6 V	–480			–480						
I _I	Input leakage current	Control input (DIR): V _I = V _{CCA} or GND	0.65 V - 3.6 V	0.65 V - 3.6 V	–0.5	0.5	–1	1	μA		
		A or B Port: V _i = V _{CCI} or GND	0.65 V - 3.6 V	0.65 V - 3.6 V	–4	4	–8	8			
I _{off}	Partial power down current	A or B Port: V _i or V _o = 0 V - 3.6 V	0 V	0 V - 3.6 V	–8	8	–12	12	μA		
			0 V - 3.6 V	0 V	–8	8	–12	12			
I _{CCA}	V _{CCA} supply current	V _I = V _{CCI} or GND	I _o = 0	0.65 V - 3.6 V	0.65 V - 3.6 V	8			12	μA	
				0 V	3.6 V	–2			–8		
				3.6 V	0 V	2			8		
I _{CCB}	V _{CCB} supply current	V _I = V _{CCI} or GND	I _o = 0	0.65 V - 3.6 V	0.65 V - 3.6 V	8			12	μA	
				0 V	3.6 V	2			8		
				3.6 V	0 V	–2			–8		
I _{CCA} + I _{CCB}	Combined supply current	V _I = V _{CCI} or GND	I _o = 0	0.65 V - 3.6 V	0.65 V - 3.6 V	10			16	μA	
C _i	Control input capacitance	V _I = 3.3 V or GND		3.3 V	3.3 V	4.3			4.3	pF	
C _{io}	Data I/O capacitance, A Port	V _O = 1.65 V DC +1 MHz -16 dBm sine wave		3.3 V	0 V	7.4			7.4	pF	
C _{io}	Data I/O capacitance, B Port	V _O = 1.65 V DC +1 MHz -16 dBm sine wave		0 V	3.3 V	7.4			7.4	pF	

(1) V_{CCI} is the VCC associated with the input port.

(2) V_{CCO} is the VCC associated with the output port.

(3) All typical data is taken at 25°C.

(4) The bus-hold circuit can sink at least the minimum low sustaining current at V_{IL}(MAX). I_{BHL} should be measured after lowering V_I to GND and then raising it to V_{IL}(MAX).

(5) The bus-hold circuit can source at least the minimum high sustaining current at V_{IH}(MIN). I_{BHH} should be measured after raising V_I to V_{CC} and then lowering it to V_{IH}(MIN).

(6) An external driver must source at least I_{BHLO} to switch this node from low to high.

(7) An external driver must sink at least I_{BHHO} to switch this node from high to low.

6.6 Switching Characteristics, $V_{CCA} = 0.7\text{ V}$

PARAMETER	FROM	TO	Test Conditions	B-Port Supply Voltage (V_{CCB})																UNIT
				0.7 ± 0.05 V		0.8 ± 0.04 V		0.9 ± 0.045 V		1.2 ± 0.1 V		1.5 ± 0.1 V		1.8 ± 0.15 V		2.5 ± 0.2 V		3.3 ± 0.3 V		
				MIN	MAX	MIN	MAX	MIN	MAX	MIN	MAX	MIN	MAX	MIN	MAX	MIN	MAX	MIN	MAX	
t_{pd} Propagation delay	A	B	-40°C to 85°C	0.5	181	0.5	119	0.5	85	0.5	51	0.5	49	0.5	52	0.5	65	0.5	152	ns
			-40°C to 125°C	0.5	181	0.5	119	0.5	85	0.5	51	0.5	49	0.5	52	0.5	65	0.5	152	
	B	A	-40°C to 85°C	0.5	181	0.5	162	0.5	136	0.5	96	0.5	91	0.5	89	0.5	88	0.5	88	
			-40°C to 125°C	0.5	181	0.5	162	0.5	136	0.5	96	0.5	91	0.5	89	0.5	88	0.5	88	
t_{dis} Disable time	DIR	A	-40°C to 85°C	0.5	152	0.5	152	0.5	152	0.5	152	0.5	152	0.5	152	0.5	152	0.5	152	ns
			-40°C to 125°C	0.5	152	0.5	152	0.5	152	0.5	152	0.5	152	0.5	152	0.5	152	0.5	152	
	DIR	B	-40°C to 85°C	0.5	170	0.5	127	0.5	102	0.5	48	0.5	42	0.5	46	0.5	58	0.5	108	
			-40°C to 125°C	0.5	170	0.5	127	0.5	102	0.5	48	0.5	42	0.5	46	0.5	58	0.5	108	
t_{en} Enable time	DIR	A	-40°C to 85°C	0.5	343	0.5	278	0.5	231	0.5	141	0.5	132	0.5	134	0.5	144	0.5	193	ns
			-40°C to 125°C	0.5	343	0.5	278	0.5	231	0.5	141	0.5	132	0.5	134	0.5	144	0.5	193	
	DIR	B	-40°C to 85°C	0.5	326	0.5	257	0.5	222	0.5	194	0.5	191	0.5	191	0.5	197	0.5	277	
			-40°C to 125°C	0.5	326	0.5	257	0.5	222	0.5	194	0.5	191	0.5	191	0.5	197	0.5	277	

6.7 Switching Characteristics, $V_{CCA} = 0.8\text{ V}$

PARAMETER	FROM	TO	Test Conditions	B-Port Supply Voltage (V_{CCB})																UNIT
				0.7 ± 0.05 V		0.8 ± 0.04 V		0.9 ± 0.045 V		1.2 ± 0.1 V		1.5 ± 0.1 V		1.8 ± 0.15 V		2.5 ± 0.2 V		3.3 ± 0.3 V		
				MIN	MAX	MIN	MAX	MIN	MAX	MIN	MAX	MIN	MAX	MIN	MAX	MIN	MAX	MIN	MAX	
t_{pd} Propagation delay	A	B	-40°C to 85°C	0.5	162	0.5	98	0.5	65	0.5	33	0.5	28	0.5	26	0.5	27	0.5	37	ns
			-40°C to 125°C	0.5	162	0.5	98	0.5	65	0.5	33	0.5	28	0.5	26	0.5	27	0.5	37	
	B	A	-40°C to 85°C	0.5	119	0.5	98	0.5	81	0.5	54	0.5	45	0.5	44	0.5	43	0.5	42	
			-40°C to 125°C	0.5	119	0.5	98	0.5	81	0.5	54	0.5	45	0.5	44	0.5	43	0.5	42	
t_{dis} Disable time	DIR	A	-40°C to 85°C	0.5	107	0.5	107	0.5	107	0.5	107	0.5	107	0.5	107	0.5	107	0.5	107	ns
			-40°C to 125°C	0.5	107	0.5	107	0.5	107	0.5	107	0.5	107	0.5	107	0.5	107	0.5	107	
	DIR	B	-40°C to 85°C	0.5	160	0.5	117	0.5	90	0.5	39	0.5	31	0.5	29	0.5	29	0.5	37	
			-40°C to 125°C	0.5	160	0.5	117	0.5	90	0.5	39	0.5	31	0.5	29	0.5	29	0.5	37	
t_{en} Enable time	DIR	A	-40°C to 85°C	0.5	268	0.5	205	0.5	165	0.5	90	0.5	74	0.5	71	0.5	70	0.5	77	ns
			-40°C to 125°C	0.5	268	0.5	205	0.5	165	0.5	90	0.5	74	0.5	71	0.5	70	0.5	77	
	DIR	B	-40°C to 85°C	0.5	257	0.5	194	0.5	161	0.5	130	0.5	125	0.5	126	0.5	125	0.5	132	
			-40°C to 125°C	0.5	257	0.5	194	0.5	161	0.5	130	0.5	125	0.5	126	0.5	125	0.5	132	

6.8 Switching Characteristics, $V_{CCA} = 0.9\text{ V}$

PARAMETER	FROM	TO	Test Conditions	B-Port Supply Voltage (V_{CCB})																UNIT
				0.7 ± 0.05 V		0.8 ± 0.04 V		0.9 ± 0.045 V		1.2 ± 0.1 V		1.5 ± 0.1 V		1.8 ± 0.15 V		2.5 ± 0.2 V		3.3 ± 0.3 V		
				MIN	MAX	MIN	MAX	MIN	MAX	MIN	MAX	MIN	MAX	MIN	MAX	MIN	MAX	MIN	MAX	
t_{pd} Propagation delay	A	B	-40°C to 85°C	0.5	135	0.5	81	0.5	54	0.5	24	0.5	18	0.5	17	0.5	15	0.5	18	ns
			-40°C to 125°C	0.5	135	0.5	81	0.5	54	0.5	24	0.5	18	0.5	17	0.5	15	0.5	18	
	B	A	-40°C to 85°C	0.5	86	0.5	65	0.5	54	0.5	41	0.5	30	0.5	26	0.5	23	0.5	23	
			-40°C to 125°C	0.5	86	0.5	65	0.5	54	0.5	41	0.5	30	0.5	26	0.5	23	0.5	23	
t_{dis} Disable time	DIR	A	-40°C to 85°C	0.5	79	0.5	79	0.5	79	0.5	79	0.5	79	0.5	79	0.5	79	0.5	79	ns
			-40°C to 125°C	0.5	79	0.5	79	0.5	79	0.5	79	0.5	79	0.5	79	0.5	79	0.5	79	
	DIR	B	-40°C to 85°C	0.5	154	0.5	111	0.5	85	0.5	34	0.5	27	0.5	25	0.5	21	0.5	23	
			-40°C to 125°C	0.5	154	0.5	111	0.5	85	0.5	34	0.5	27	0.5	25	0.5	21	0.5	23	
t_{en} Enable time	DIR	A	-40°C to 85°C	0.5	227	0.5	166	0.5	131	0.5	71	0.5	53	0.5	48	0.5	42	0.5	44	ns
			-40°C to 125°C	0.5	227	0.5	166	0.5	131	0.5	71	0.5	53	0.5	48	0.5	42	0.5	44	
	DIR	B	-40°C to 85°C	0.5	206	0.5	152	0.5	125	0.5	96	0.5	91	0.5	89	0.5	89	0.5	92	
			-40°C to 125°C	0.5	206	0.5	152	0.5	125	0.5	96	0.5	91	0.5	89	0.5	89	0.5	92	

6.9 Switching Characteristics, $V_{CCA} = 1.2\text{ V}$

PARAMETER	FROM	TO	Test Conditions	B-Port Supply Voltage (V_{CCB})																UNIT
				0.7 ± 0.05 V		0.8 ± 0.04 V		0.9 ± 0.045 V		1.2 ± 0.1 V		1.5 ± 0.1 V		1.8 ± 0.15 V		2.5 ± 0.2 V		3.3 ± 0.3 V		
				MIN	MAX	MIN	MAX	MIN	MAX	MIN	MAX	MIN	MAX	MIN	MAX	MIN	MAX	MIN	MAX	
t_{pd} Propagation delay	A	B	-40°C to 85°C	0.5	95	0.5	54	0.5	41	0.5	16	0.5	11	0.5	9	0.5	8	0.5	8	ns
			-40°C to 125°C	0.5	95	0.5	54	0.5	41	0.5	16	0.5	11	0.5	9	0.5	8	0.5	8	
	B	A	-40°C to 85°C	0.5	51	0.5	33	0.5	24	0.5	16	0.5	13	0.5	11	0.5	8	0.5	8	
			-40°C to 125°C	0.5	51	0.5	33	0.5	24	0.5	16	0.5	13	0.5	11	0.5	8	0.5	8	
t_{dis} Disable time	DIR	A	-40°C to 85°C	0.5	28	0.5	28	0.5	28	0.5	28	0.5	28	0.5	28	0.5	28	0.5	28	ns
			-40°C to 125°C	0.5	28	0.5	28	0.5	28	0.5	28	0.5	28	0.5	28	0.5	28	0.5	28	
	DIR	B	-40°C to 85°C	0.5	148	0.5	105	0.5	78	0.5	30	0.5	23	0.5	20	0.5	16	0.5	16	
			-40°C to 125°C	0.5	148	0.5	105	0.5	78	0.5	30	0.5	23	0.5	20	0.5	16	0.5	16	
t_{en} Enable time	DIR	A	-40°C to 85°C	0.5	191	0.5	129	0.5	96	0.5	43	0.5	34	0.5	30	0.5	23	0.5	22	ns
			-40°C to 125°C	0.5	191	0.5	129	0.5	96	0.5	43	0.5	34	0.5	30	0.5	23	0.5	22	
	DIR	B	-40°C to 85°C	0.5	116	0.5	75	0.5	61	0.5	41	0.5	37	0.5	36	0.5	35	0.5	35	
			-40°C to 125°C	0.5	116	0.5	75	0.5	61	0.5	41	0.5	37	0.5	36	0.5	35	0.5	35	

6.10 Switching Characteristics, $V_{CCA} = 1.5\text{ V}$

PARAMETER	FROM	TO	Test Conditions	B-Port Supply Voltage (V_{CCB})														UNIT			
				0.7 ± 0.05 V		0.8 ± 0.04 V		0.9 ± 0.045 V		1.2 ± 0.1 V		1.5 ± 0.1 V		1.8 ± 0.15 V		2.5 ± 0.2 V			3.3 ± 0.3 V		
				MIN	MAX	MIN	MAX	MIN	MAX	MIN	MAX	MIN	MAX	MIN	MAX	MIN	MAX		MIN	MAX	
t_{pd} Propagation delay	A	B	-40°C to 85°C	0.5	91	0.5	45	0.5	30	0.5	13	0.5	9	0.5	8	0.5	6	0.5	6	ns	
			-40°C to 125°C	0.5	91	0.5	45	0.5	30	0.5	13	0.5	9	0.5	8	0.5	6	0.5	6		
	B	A	-40°C to 85°C	0.5	49	0.5	28	0.5	18	0.5	11	0.5	9	0.5	8	0.5	6	0.5	5		ns
			-40°C to 125°C	0.5	49	0.5	28	0.5	18	0.5	11	0.5	9	0.5	8	0.5	6	0.5	5		
t_{dis} Disable time	DIR	A	-40°C to 85°C	0.5	20	0.5	20	0.5	20	0.5	20	0.5	20	0.5	20	0.5	20	0.5	20	ns	
			-40°C to 125°C	0.5	20	0.5	20	0.5	20	0.5	20	0.5	20	0.5	20	0.5	20	0.5	20		
	DIR	B	-40°C to 85°C	0.5	146	0.5	103	0.5	76	0.5	28	0.5	21	0.5	19	0.5	15	0.5	14	ns	
			-40°C to 125°C	0.5	146	0.5	103	0.5	76	0.5	28	0.5	21	0.5	19	0.5	15	0.5	14		
t_{en} Enable time	DIR	A	-40°C to 85°C	0.5	186	0.5	124	0.5	89	0.5	38	0.5	29	0.5	26	0.5	20	0.5	18	ns	
			-40°C to 125°C	0.5	186	0.5	124	0.5	89	0.5	38	0.5	29	0.5	26	0.5	20	0.5	18		
	DIR	B	-40°C to 85°C	0.5	104	0.5	58	0.5	43	0.5	31	0.5	28	0.5	27	0.5	25	0.5	25	ns	
			-40°C to 125°C	0.5	104	0.5	58	0.5	43	0.5	31	0.5	28	0.5	27	0.5	25	0.5	25		

6.11 Switching Characteristics, $V_{CCA} = 1.8\text{ V}$

PARAMETER	FROM	TO	Test Conditions	B-Port Supply Voltage (V_{CCB})														UNIT			
				0.7 ± 0.05 V		0.8 ± 0.04 V		0.9 ± 0.045 V		1.2 ± 0.1 V		1.5 ± 0.1 V		1.8 ± 0.15 V		2.5 ± 0.2 V			3.3 ± 0.3 V		
				MIN	MAX	MIN	MAX	MIN	MAX	MIN	MAX	MIN	MAX	MIN	MAX	MIN	MAX		MIN	MAX	
t_{pd} Propagation delay	A	B	-40°C to 85°C	0.5	89	0.5	44	0.5	26	0.5	11	0.5	8	0.5	7	0.5	6	0.5	5	ns	
			-40°C to 125°C	0.5	89	0.5	44	0.5	26	0.5	11	0.5	8	0.5	7	0.5	6	0.5	5		
	B	A	-40°C to 85°C	0.5	52	0.5	26	0.5	17	0.5	9	0.5	8	0.5	7	0.5	6	0.5	5		ns
			-40°C to 125°C	0.5	52	0.5	26	0.5	17	0.5	9	0.5	8	0.5	7	0.5	6	0.5	5		
t_{dis} Disable time	DIR	A	-40°C to 85°C	0.5	17	0.5	17	0.5	17	0.5	17	0.5	17	0.5	17	0.5	17	0.5	17	ns	
			-40°C to 125°C	0.5	17	0.5	17	0.5	17	0.5	17	0.5	17	0.5	17	0.5	17	0.5	17		
	DIR	B	-40°C to 85°C	0.5	147	0.5	103	0.5	76	0.5	27	0.5	20	0.5	18	0.5	14	0.5	13	ns	
			-40°C to 125°C	0.5	147	0.5	103	0.5	76	0.5	27	0.5	20	0.5	18	0.5	14	0.5	13		
t_{en} Enable time	DIR	A	-40°C to 85°C	0.5	185	0.5	122	0.5	86	0.5	35	0.5	27	0.5	24	0.5	19	0.5	17	ns	
			-40°C to 125°C	0.5	185	0.5	122	0.5	86	0.5	35	0.5	27	0.5	24	0.5	19	0.5	17		
	DIR	B	-40°C to 85°C	0.5	100	0.5	54	0.5	37	0.5	27	0.5	25	0.5	24	0.5	22	0.5	22	ns	
			-40°C to 125°C	0.5	100	0.5	54	0.5	37	0.5	27	0.5	25	0.5	24	0.5	22	0.5	22		

6.12 Switching Characteristics, $V_{CCA} = 2.5\text{ V}$

PARAMETER	FROM	TO	Test Conditions	B-Port Supply Voltage (V_{CCB})																UNIT	
				0.7 ± 0.05 V		0.8 ± 0.04 V		0.9 ± 0.045 V		1.2 ± 0.1 V		1.5 ± 0.1 V		1.8 ± 0.15 V		2.5 ± 0.2 V		3.3 ± 0.3 V			
				MIN	MAX	MIN	MAX	MIN	MAX	MIN	MAX	MIN	MAX	MIN	MAX	MIN	MAX	MIN	MAX		
t_{pd} Propagation delay	A	B	-40°C to 85°C	0.5	88	0.5	42	0.5	23	0.5	8	0.5	6	0.5	6	0.5	5	0.5	5	ns	
			-40°C to 125°C	0.5	88	0.5	42	0.5	23	0.5	8	0.5	6	0.5	6	0.5	5	0.5	5		
	B	A	-40°C to 85°C	0.5	65	0.5	27	0.5	15	0.5	8	0.5	6	0.5	6	0.5	5	0.5	4		ns
			-40°C to 125°C	0.5	65	0.5	27	0.5	15	0.5	8	0.5	6	0.5	6	0.5	5	0.5	4		
t_{dis} Disable time	DIR	A	-40°C to 85°C	0.5	13	0.5	13	0.5	13	0.5	13	0.5	13	0.5	13	0.5	13	0.5	13	ns	
			-40°C to 125°C	0.5	13	0.5	13	0.5	13	0.5	13	0.5	13	0.5	13	0.5	13	0.5	13		
	DIR	B	-40°C to 85°C	0.5	146	0.5	102	0.5	75	0.5	27	0.5	19	0.5	17	0.5	13	0.5	12	ns	
			-40°C to 125°C	0.5	146	0.5	102	0.5	75	0.5	27	0.5	19	0.5	17	0.5	13	0.5	12		
t_{en} Enable time	DIR	A	-40°C to 85°C	0.5	191	0.5	122	0.5	85	0.5	33	0.5	25	0.5	22	0.5	17	0.5	16	ns	
			-40°C to 125°C	0.5	191	0.5	122	0.5	85	0.5	33	0.5	25	0.5	22	0.5	17	0.5	16		
	DIR	B	-40°C to 85°C	0.5	95	0.5	50	0.5	31	0.5	20	0.5	18	0.5	17	0.5	17	0.5	17	ns	
			-40°C to 125°C	0.5	95	0.5	50	0.5	31	0.5	20	0.5	18	0.5	17	0.5	17	0.5	17		

6.13 Switching Characteristics, $V_{CCA} = 3.3\text{ V}$

PARAMETER	FROM	TO	Test Conditions	B-Port Supply Voltage (V_{CCB})																UNIT	
				0.7 ± 0.05 V		0.8 ± 0.04 V		0.9 ± 0.045 V		1.2 ± 0.1 V		1.5 ± 0.1 V		1.8 ± 0.15 V		2.5 ± 0.2 V		3.3 ± 0.3 V			
				MIN	MAX	MIN	MAX	MIN	MAX	MIN	MAX	MIN	MAX	MIN	MAX	MIN	MAX	MIN	MAX		
t_{pd} Propagation delay	A	B	-40°C to 85°C	0.5	87	0.5	42	0.5	23	0.5	8	0.5	5	0.5	5	0.5	4	0.5	4	ns	
			-40°C to 125°C	0.5	87	0.5	42	0.5	23	0.5	8	0.5	5	0.5	5	0.5	4	0.5	4		
	B	A	-40°C to 85°C	0.5	154	0.5	37	0.5	18	0.5	8	0.5	6	0.5	5	0.5	5	0.5	4		ns
			-40°C to 125°C	0.5	154	0.5	37	0.5	18	0.5	8	0.5	6	0.5	5	0.5	5	0.5	4		
t_{dis} Disable time	DIR	A	-40°C to 85°C	0.5	12	0.5	12	0.5	12	0.5	12	0.5	12	0.5	12	0.5	12	0.5	12	ns	
			-40°C to 125°C	0.5	12	0.5	12	0.5	12	0.5	12	0.5	12	0.5	12	0.5	12	0.5	12		
	DIR	B	-40°C to 85°C	0.5	147	0.5	102	0.5	75	0.5	26	0.5	19	0.5	17	0.5	13	0.5	12	ns	
			-40°C to 125°C	0.5	147	0.5	102	0.5	75	0.5	26	0.5	19	0.5	17	0.5	13	0.5	12		
t_{en} Enable time	DIR	A	-40°C to 85°C	0.5	275	0.5	129	0.5	88	0.5	34	0.5	24	0.5	21	0.5	17	0.5	16	ns	
			-40°C to 125°C	0.5	275	0.5	129	0.5	88	0.5	34	0.5	24	0.5	21	0.5	17	0.5	16		
	DIR	B	-40°C to 85°C	0.5	94	0.5	49	0.5	30	0.5	18	0.5	16	0.5	16	0.5	15	0.5	15	ns	
			-40°C to 125°C	0.5	94	0.5	49	0.5	30	0.5	18	0.5	16	0.5	16	0.5	15	0.5	15		

6.14 Operating Characteristics: $T_A = 25^\circ\text{C}$

PARAMETER		TEST CONDITIONS	V_{CCA}	V_{CCB}	MIN	TYP	MAX	UNIT
C_{pdA}	Power Dissipation Capacitance per transceiver (A to B: outputs enabled)	CL = 0, RL = Open f = 1 MHz, tr = tf = 1 ns	0.7 V	0.7 V		2.0		pF
			0.8 V	0.8 V		2.0		
			0.9 V	0.9 V		2.0		
			1.2 V	1.2 V		2.0		
			1.5 V	1.5 V		1.9		
			1.8 V	1.8 V		2.0		
			2.5 V	2.5 V		2.4		
			3.3 V	3.3 V		3.0		
	Power Dissipation Capacitance per transceiver (B to A: outputs enabled)	CL = 0, RL = Open f = 1 MHz, tr = tf = 1 ns	0.7 V	0.7 V		12		pF
			0.8 V	0.8 V		12		
			0.9 V	0.9 V		12		
			1.2 V	1.2 V		12		
			1.5 V	1.5 V		13		
			1.8 V	1.8 V		13		
2.5 V			2.5 V		17			
3.3 V			3.3 V		21			
C_{pdB}	Power Dissipation Capacitance per transceiver (A to B: outputs enabled)	CL = 0, RL = Open f = 1 MHz, tr = tf = 1 ns	0.7 V	0.7 V		12		pF
			0.8 V	0.8 V		12		
			0.9 V	0.9 V		12		
			1.2 V	1.2 V		12		
			1.5 V	1.5 V		13		
			1.8 V	1.8 V		13		
			2.5 V	2.5 V		17		
			3.3 V	3.3 V		21		
	Power Dissipation Capacitance per transceiver (B to A: outputs enabled)	CL = 0, RL = Open f = 1 MHz, tr = tf = 1 ns	0.7 V	0.7 V		2.1		pF
			0.8 V	0.8 V		2.2		
			0.9 V	0.9 V		2.2		
			1.2 V	1.2 V		2.2		
			1.5 V	1.5 V		2.3		
			1.8 V	1.8 V		2.3		
2.5 V			2.5 V		2.6			
3.3 V			3.3 V		3.3			

6.15 Typical Characteristics

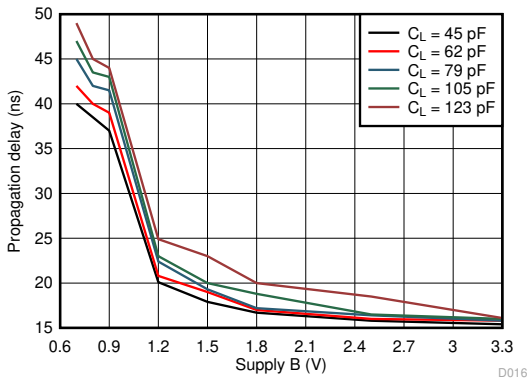

$T_A = 25^\circ\text{C}$ $V_{CCA} = 0.7\text{ V}$

Figure 6-1. Typical Propagation Delay of Low-to-High (A to B) vs Load Capacitance

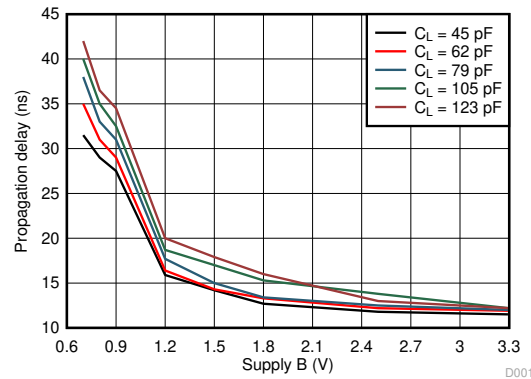

$T_A = 25^\circ\text{C}$ $V_{CCA} = 0.8\text{ V}$

Figure 6-2. Typical Propagation Delay of Low-to-High (A to B) vs Load Capacitance

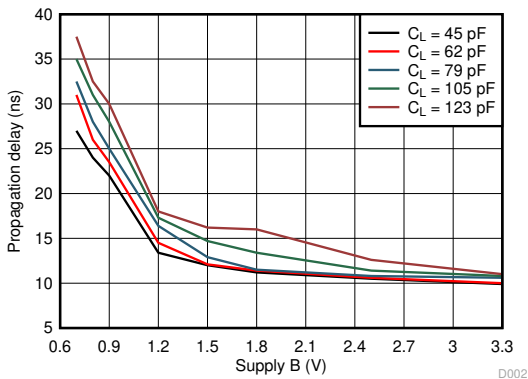

$T_A = 25^\circ\text{C}$ $V_{CCA} = 0.9\text{ V}$

Figure 6-3. Typical Propagation Delay of Low-to-High (A to B) vs Load Capacitance

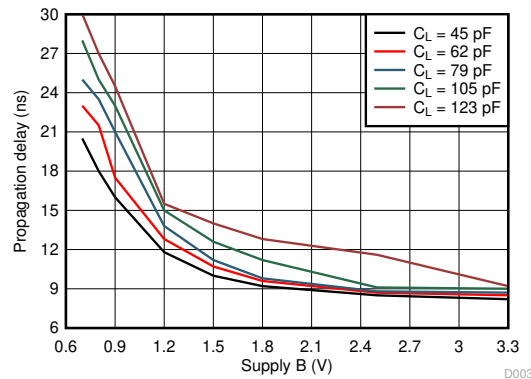

$T_A = 25^\circ\text{C}$ $V_{CCA} = 1.2\text{ V}$

Figure 6-4. Typical Propagation Delay of Low-to-High (A to B) vs Load Capacitance

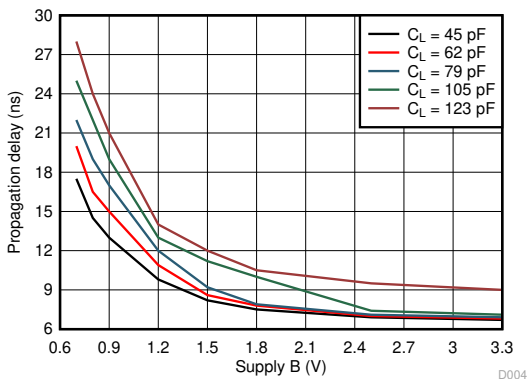

$T_A = 25^\circ\text{C}$ $V_{CCA} = 1.5\text{ V}$

Figure 6-5. Typical Propagation Delay of Low-to-High (A to B) vs Load Capacitance

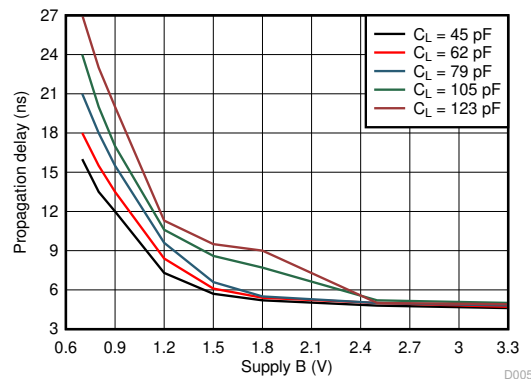

$T_A = 25^\circ\text{C}$ $V_{CCA} = 1.8\text{ V}$

Figure 6-6. Typical Propagation Delay of Low-to-High (A to B) vs Load Capacitance

6.15 Typical Characteristics (continued)

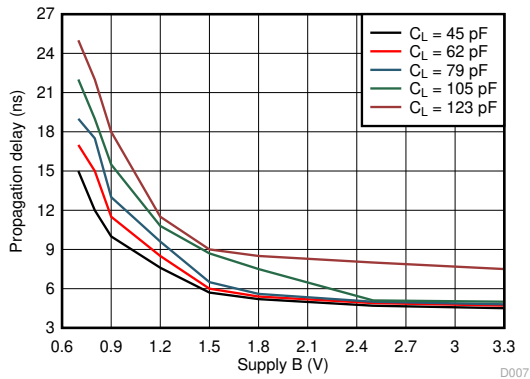

$T_A = 25^\circ\text{C}$ $V_{CCA} = 3.3\text{ V}$

Figure 6-7. Typical Propagation Delay of Low-to-High (A to B) vs Load Capacitance

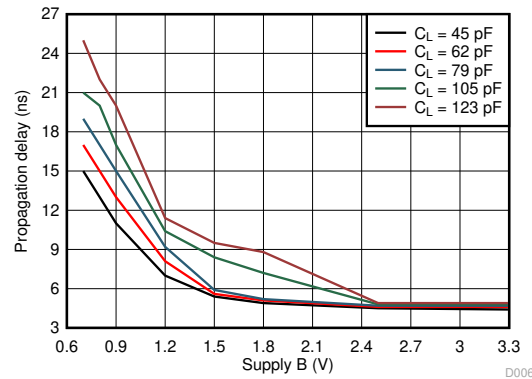

$T_A = 25^\circ\text{C}$ $V_{CCA} = 2.5\text{ V}$

Figure 6-8. Typical Propagation Delay of Low-to-High (A to B) vs Load Capacitance

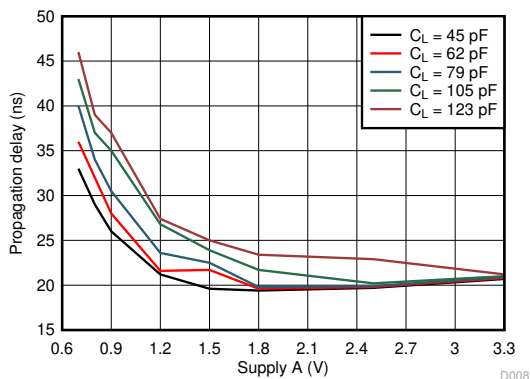

$T_A = 25^\circ\text{C}$ $V_{CCA} = 0.7\text{ V}$

Figure 6-9. Typical Propagation Delay of Low-to-High (B to A) vs Load Capacitance

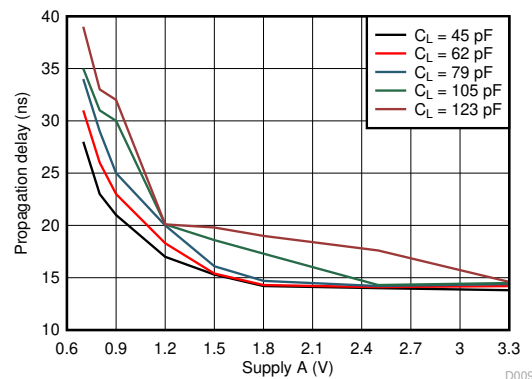

$T_A = 25^\circ\text{C}$ $V_{CCA} = 0.8\text{ V}$

Figure 6-10. Typical Propagation Delay of Low-to-High (B to A) vs Load Capacitance

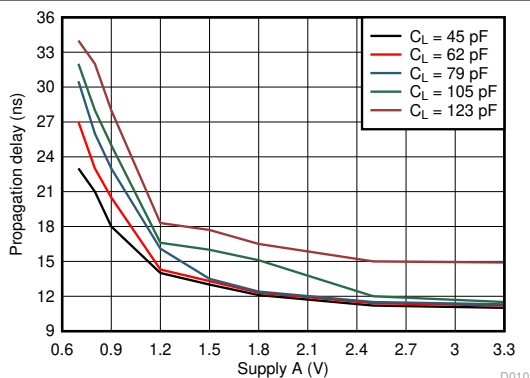

$T_A = 25^\circ\text{C}$ $V_{CCA} = 0.9\text{ V}$

Figure 6-11. Typical Propagation Delay of Low-to-High (B to A) vs Load Capacitance

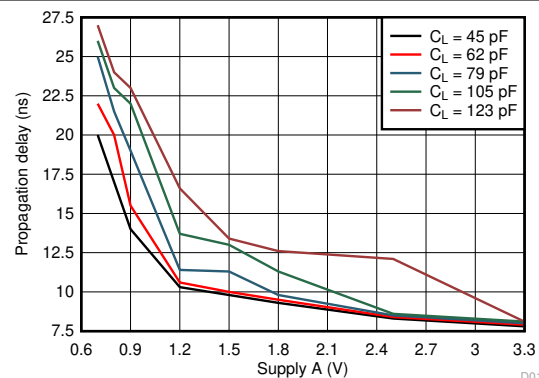

$T_A = 25^\circ\text{C}$ $V_{CCA} = 1.2\text{ V}$

Figure 6-12. Typical Propagation Delay of Low-to-High (B to A) vs Load Capacitance

6.15 Typical Characteristics (continued)

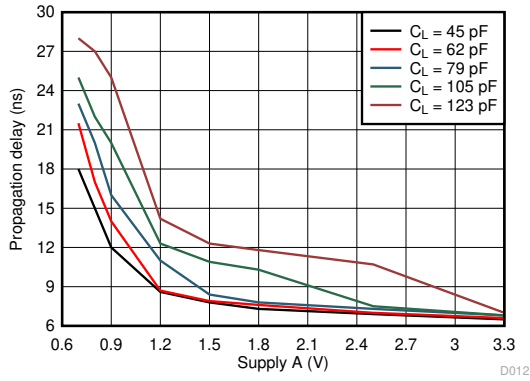

$T_A = 25^\circ\text{C}$ $V_{CCA} = 1.5\text{ V}$

Figure 6-13. Typical Propagation Delay of Low-to-High (B to A) vs Load Capacitance

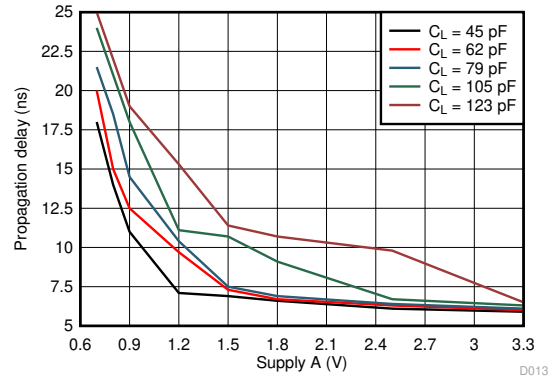

$T_A = 25^\circ\text{C}$ $V_{CCA} = 1.8\text{ V}$

Figure 6-14. Typical Propagation Delay of Low-to-High (B to A) vs Load Capacitance

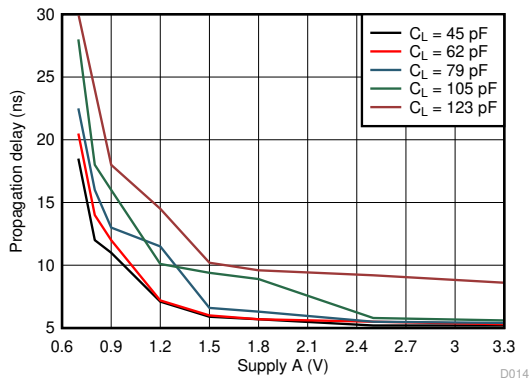

$T_A = 25^\circ\text{C}$ $V_{CCA} = 2.5\text{ V}$

Figure 6-15. Typical Propagation Delay of Low-to-High (B to A) vs Load Capacitance

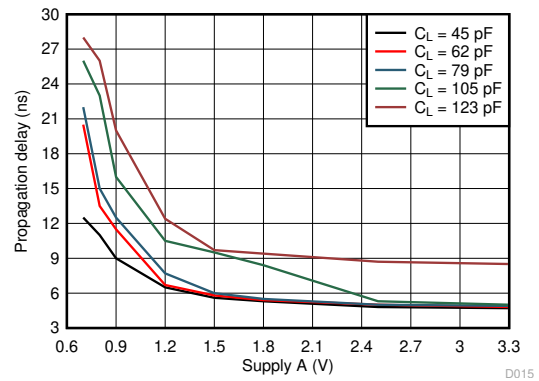

$T_A = 25^\circ\text{C}$ $V_{CCA} = 3.3\text{ V}$

Figure 6-16. Typical Propagation Delay of Low-to-High (B to A) vs Load Capacitance

7 Parameter Measurement Information

7.1 Load Circuit and Voltage Waveforms

Unless otherwise noted, all input pulses are supplied by generators having the following characteristics:

- $f = 1 \text{ MHz}$
- $Z_O = 50 \Omega$
- $dv/dt \leq 1 \text{ ns/V}$

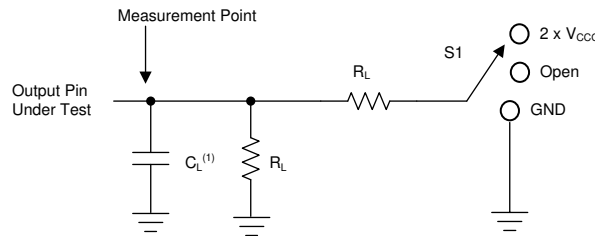

A. C_L includes probe and jig capacitance.

Figure 7-1. Load Circuit

Table 7-1. Load Circuit Conditions

Parameter	V_{CCO}	R_L	C_L	S_1	V_{TP}
$\Delta t/\Delta v$ Input transition rise or fall rate	0.65 V – 3.6 V	1 M Ω	15 pF	Open	N/A
t_{pd} Propagation (delay) time	1.1 V – 3.6 V	2 k Ω	15 pF	Open	N/A
	0.65 V – 0.95 V	20 k Ω	15 pF	Open	N/A
t_{en}, t_{dis} Enable time, disable time	3 V – 3.6 V	2 k Ω	15 pF	$2 \times V_{CCO}$	0.3 V
	1.65 V – 2.7 V	2 k Ω	15 pF	$2 \times V_{CCO}$	0.15 V
	1.1 V – 1.6 V	2 k Ω	15 pF	$2 \times V_{CCO}$	0.1 V
	0.65 V – 0.95 V	20 k Ω	15 pF	$2 \times V_{CCO}$	0.1 V
t_{en}, t_{dis} Enable time, disable time	3 V – 3.6 V	2 k Ω	15 pF	GND	0.3 V
	1.65 V – 2.7 V	2 k Ω	15 pF	GND	0.15 V
	1.1 V – 1.6 V	2 k Ω	15 pF	GND	0.1 V
	0.65 V – 0.95 V	20 k Ω	15 pF	GND	0.1 V

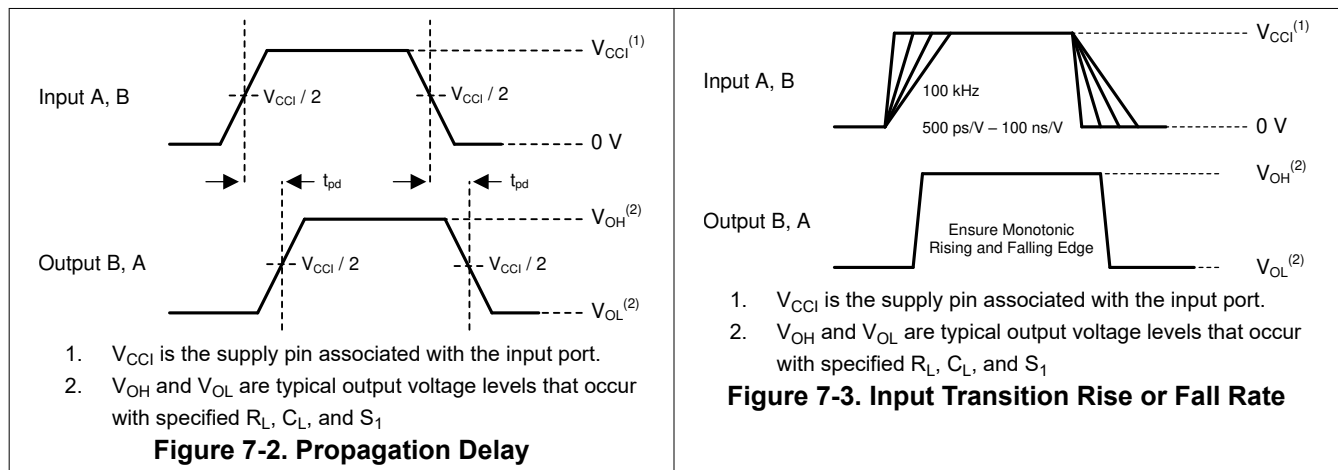

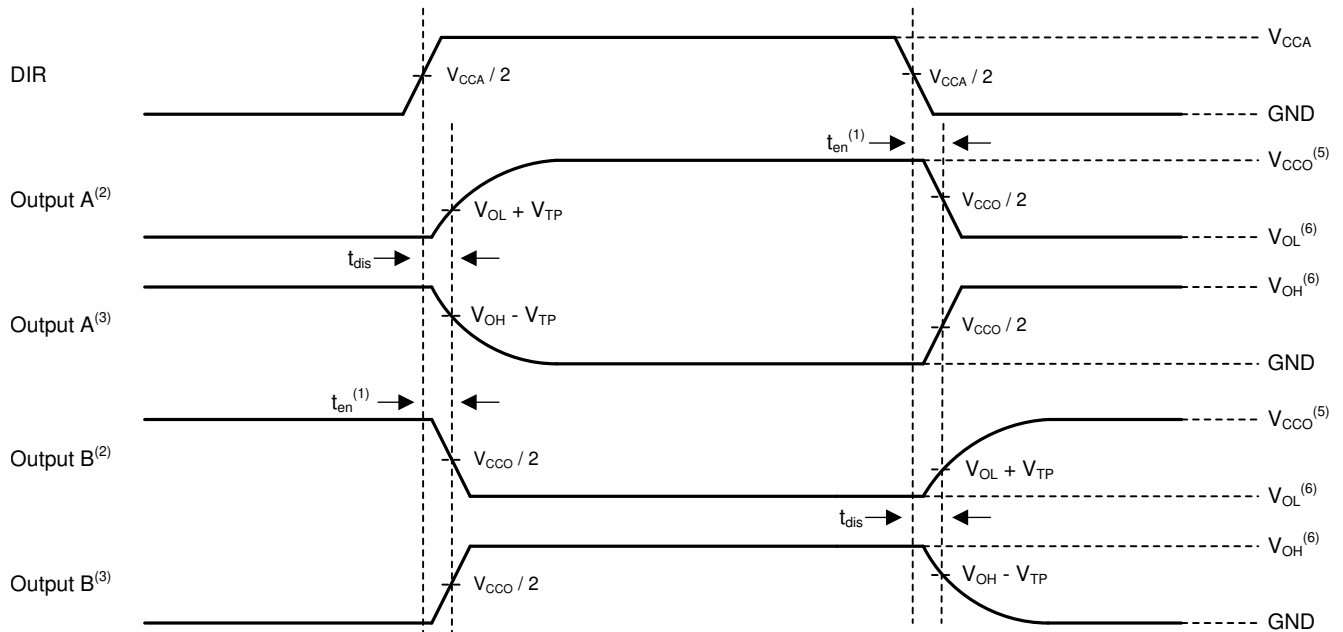

1. Illustrative purposes only. Enable Time is a calculation as described in the data sheet.
2. Output waveform on the condition that input is driven to a valid Logic Low.
3. Output waveform on the condition that input is driven to a valid Logic High.
4. V_{CCI} is the supply pin associated with the input port
5. V_{CCO} is the supply pin associated with the output port.
6. V_{OH} and V_{OL} are typical output voltage levels that occur with specified R_L , C_L , and S_1

Figure 7-4. Disable and Enable Time

8 Detailed Description

8.1 Overview

The SN74AXCH1T45 is single-bit, dual-supply, noninverting voltage level translator. Pin A and the direction control pin are referenced to V_{CCA} logic levels and pin B is referenced to V_{CCB} logic levels, as depicted in . The A port can accept I/O voltages ranging from 0.65 V to 3.6 V, and the B port can accept I/O voltages from 0.65 V to 3.6 V. A logic high on the DIR pin enables data transmission from A to B and a logic low on the DIR pin enables data transmission from B to A.

8.2 Functional Block Diagram

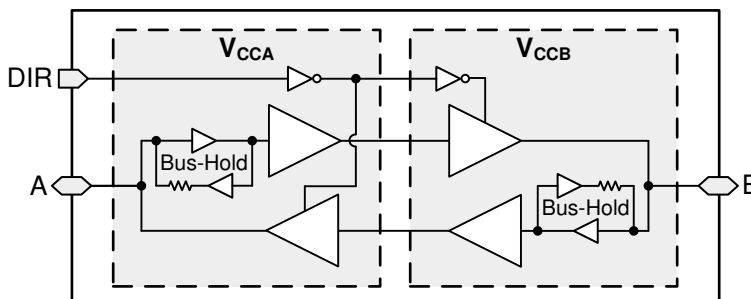

8.3 Feature Description

8.3.1 Standard CMOS Inputs

Standard CMOS inputs are high impedance and are typically modeled as a resistor in parallel with the input capacitance given in the [Electrical Characteristics](#). The worst case resistance is calculated with the maximum input voltage, given in the [Absolute Maximum Ratings](#), and the maximum input leakage current, given in the [Electrical Characteristics](#), using ohm's law ($R = V \div I$).

Signals applied to the inputs need to have fast edge rates, as defined by $\Delta t/\Delta v$ in [Recommended Operating Conditions](#) to avoid excessive current consumption and oscillations. If a slow or noisy input signal is required, a device with a Schmitt-trigger input should be used to condition the input signal prior to the standard CMOS input.

8.3.2 Balanced High-Drive CMOS Push-Pull Outputs

A balanced output allows the device to sink and source similar currents. The high drive capability of this device creates fast edges into light loads so routing and load conditions should be considered to prevent ringing. Additionally, the outputs of this device are capable of driving larger currents than the device can sustain without being damaged. The electrical and thermal limits defined in the [Absolute Maximum Ratings](#) must be followed at all times.

8.3.3 Partial Power Down (I_{off})

The inputs and outputs for this device enter a high-impedance state when the device is powered down, inhibiting current backflow into the device. The maximum leakage into or out of any input or output pin on the device is specified by I_{off} in the [Electrical Characteristics](#).

8.3.4 V_{CC} Isolation

The inputs and outputs for this device enter a high-impedance state when either supply is $<100\text{mV}$.

8.3.5 Over-Voltage Tolerant Inputs

Input signals to this device can be driven above the supply voltage so long as they remain below the maximum input voltage value specified in the [Recommended Operating Conditions](#).

8.3.6 Negative Clamping Diodes

The inputs and outputs to this device have negative clamping diodes as depicted in [Figure 8-1](#).

CAUTION

Voltages beyond the values specified in the [Absolute Maximum Ratings](#) table can cause damage to the device. The input negative-voltage and output voltage ratings may be exceeded if the input and output clamp-current ratings are observed.

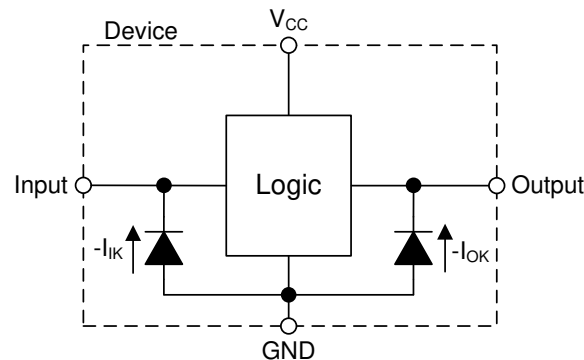

Figure 8-1. Electrical Placement of Clamping Diodes for Each Input and Output

8.3.7 Fully Configurable Dual-Rail Design

Both the V_{CCA} and V_{CCB} pins can be supplied at any voltage from 0.65 V to 3.6 V, making the device suitable for translating between any of the voltage nodes (0.7 V, 0.8 V, 0.9 V, 1.2 V, 1.8 V, 2.5 V and 3.3 V).

8.3.8 Supports High-Speed Translation

The SN74AXCH1T45 device can support high data-rate applications. The translated signal data rate can be up to 500 Mbps when the signal is translated from 1.8 V to 3.3 V.

8.3.9 Bus-Hold Data Inputs

Each data input on this device includes a weak latch that maintains a valid logic level on the input. The state of these latches is unknown at startup and remains unknown until the input has been forced to a valid high or low state. After data has been sent through a channel, the latch then maintains the previous state on the input if the line is left floating. It is not recommended to use pull-up or pull-down resistors together with a bus-hold input, as it may cause undefined inputs to occur which leads to excessive current consumption.

Bus-hold data inputs prevent floating inputs on this device. The [Implications of Slow or Floating CMOS Inputs](#) application report explains the problems associated with leaving CMOS inputs floating.

These latches remain active at all times, independent of all control signals such as direction control or output enable.

The [Bus-Hold Circuit](#) application report has additional details regarding bus-hold inputs.

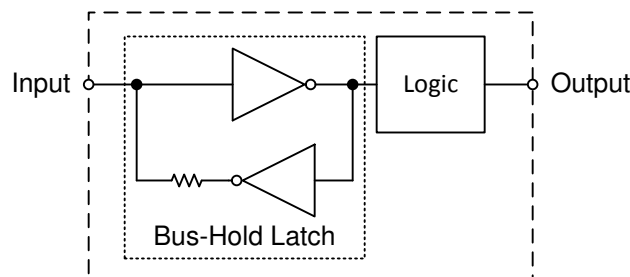

Figure 8-2. Simplified Schematic for Device With Bus-Hold Data Inputs

8.4 Device Functional Modes

Table 8-1 lists the device functions for the DIR input.

Table 8-1. Function Table

INPUT ⁽¹⁾ DIR	OPERATION
L	B data to A bus
H	A data to B bus

(1) Input circuits of the data I/Os always are active.

9 Application and Implementation

Note

Information in the following applications sections is not part of the TI component specification, and TI does not warrant its accuracy or completeness. TI's customers are responsible for determining suitability of components for their purposes, as well as validating and testing their design implementation to confirm system functionality.

9.1 Application Information

The SN74AXCH1T45 device can be used in level-translation applications for interfacing devices or systems with one another when they are operating at different interface voltages. The maximum data rate can be up to 500 Mbps when the device translate signals from 1.8 V to 3.3 V.

9.1.1 Enable Times

Calculate the enable times for the SN74AXC1T45 using the following formulas:

$$t_{A_en} (\text{DIR to A}) = t_{dis} (\text{DIR to B}) + t_{pd} (\text{B to A}) \quad (1)$$

$$t_{B_en} (\text{DIR to B}) = t_{dis} (\text{DIR to A}) + t_{pd} (\text{A to B}) \quad (2)$$

In a bidirectional application, these enable times provide the maximum delay time from the time the DIR bit is switched until an output is expected. For example, if the SN74AXCH1T45 initially is transmitting from A to B, then the DIR bit is switched; the B port of the device must be disabled (t_{dis}) before presenting it with an input. After the B port has been disabled, an input signal applied to it appears on the corresponding A port after the specified propagation delay (t_{pd}). To avoid bus contention care should be taken to not apply an input signal prior to the output port being disabled ($t_{dis\ max}$).

9.2 Typical Applications

9.2.1 Interrupt Request Application

Figure 9-1 shows an example of the SN74AXCH1T45 being used in an application where a system controller flags an interrupt request (IRQ) to the CPU. The system controller determines the direction of the IRQ line to either flag an interrupt to the CPU or allow the CPU to drive data on the line. In this application the controller is operating at 3.3 V while the CPU can be operating as low as 0.65 V.

The SN74AXCH1T45 device is used to ensure that these devices can communicate at the appropriate voltage levels. Because the SN74AXCH1T45 does not have an output-enable (\overline{OE}) pin, the system designer should take precautions to avoid bus contention between the CPU and controller when changing directions.

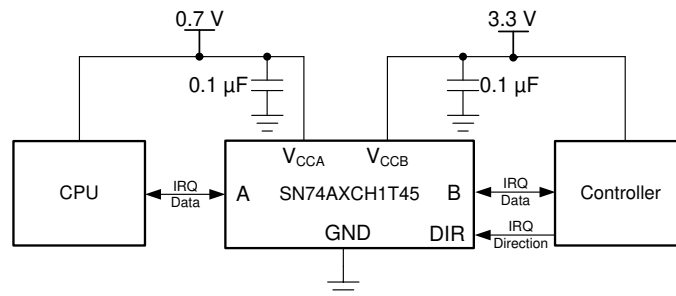

Figure 9-1. Interrupt Request Application

9.2.1.1 Design Requirements

For this design example, use the parameters listed in [Table 9-1](#).

Table 9-1. Design Parameters

DESIGN PARAMETERS	EXAMPLE VALUES
Input voltage range	0.65 V to 3.6 V
Output voltage range	0.65 V to 3.6 V

9.2.1.2 Detailed Design Procedure

To begin the design process, determine the following:

- Input voltage range
 - Use the supply voltage of the device that is driving the SN74AXCH1T45 device to determine the input voltage range. For a valid logic-high, the value must exceed the high-level input voltage (V_{IH}) of the input port. For a valid logic low the value must be less than the low-level input voltage (V_{IL}) of the input port.
- Output voltage range
 - Use the supply voltage of the device that the SN74AXCH1T45 device is driving to determine the output voltage range.

9.2.1.3 Application Curve

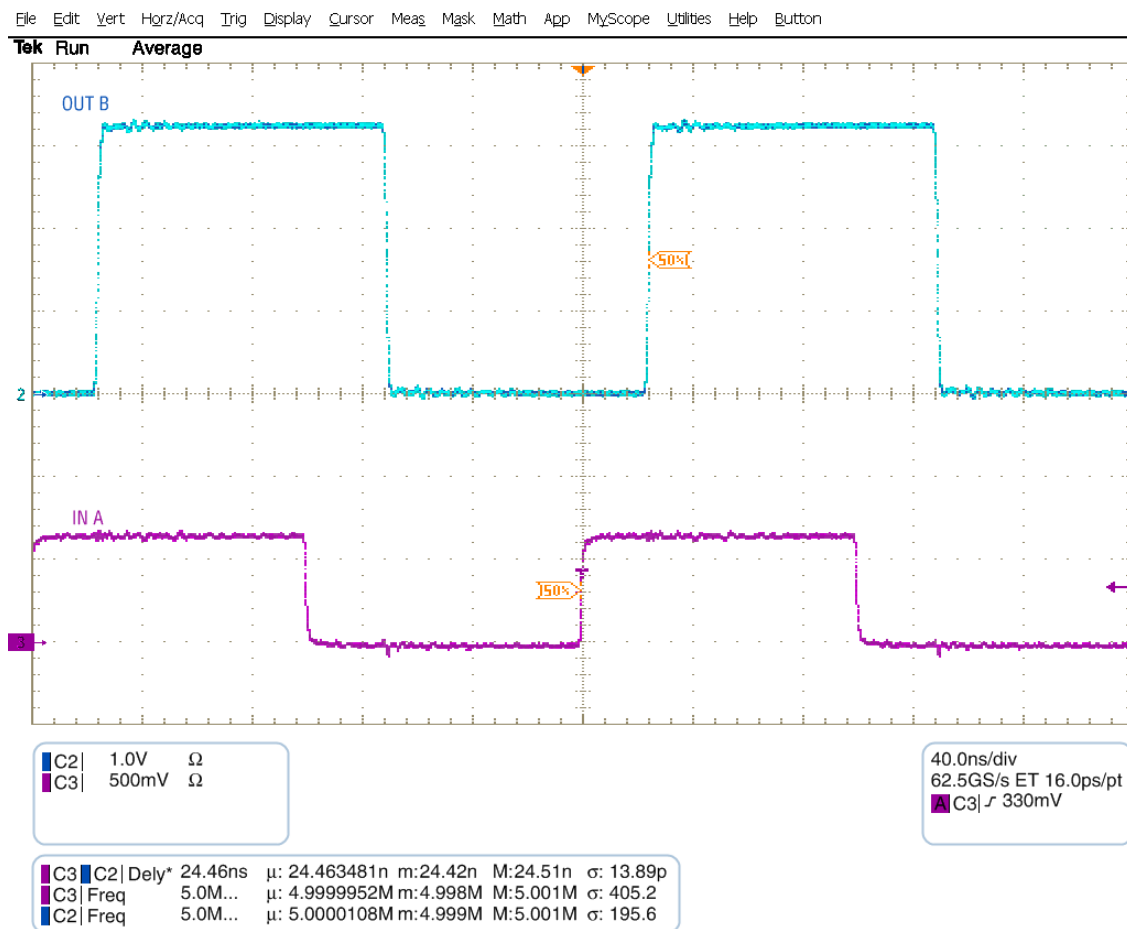

Figure 9-2. Up Translation at 2.5 MHz (0.7 V to 3.3 V)

9.2.2 Universal Asynchronous Receiver-Transmitter (UART) Interface Application

Figure 9-3 shows the SN74AXCH1T45 being used for the two-bit UART interface application. One SN74AXCH1T45 device is used to level shift the voltage and drive the TX from the processor to the GPS Module while a second SN74AXCH1T45 device is used to drive the TX Data line from the GPS Module to the Processor. Devices with bus-hold inputs remove the requirement for external pullup resistors to maintain a valid logic level at the input.

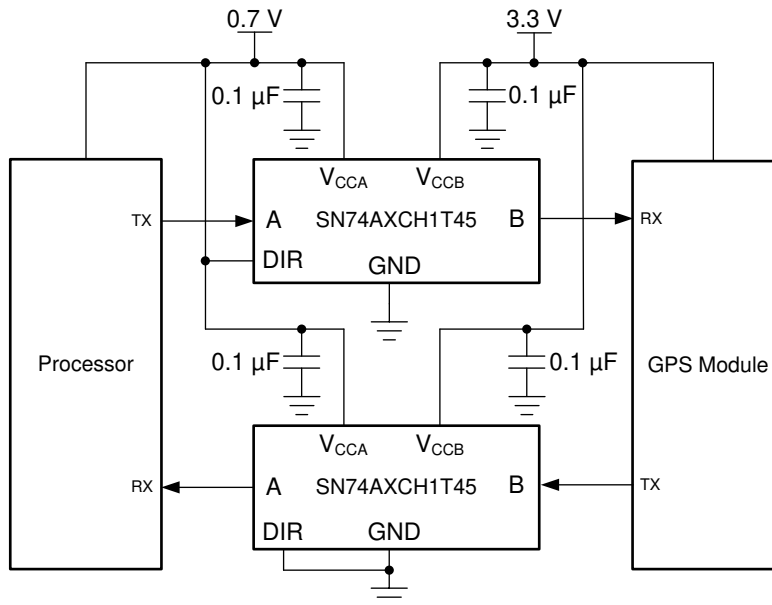

Figure 9-3. UART Interface Application

9.2.2.1 Design Requirements

Refer to [Design Requirements](#).

9.2.2.2 Detailed Design Procedure

Refer to [Detailed Design Procedure](#).

10 Power Supply Recommendations

Always apply a ground reference to the GND pins first. This device is designed for glitch free power sequencing without any supply sequencing requirements such as ramp order or ramp rate.

This device was designed with various power supply sequencing methods in mind to help prevent unintended triggering of downstream devices. For more information regarding the power up glitch performance of the AXC family of level translators, see the [Power Sequencing for AXC Family of Devices](#) application report.

11 Layout

11.1 Layout Guidelines

To ensure reliability of the device, following common printed-circuit board layout guidelines are recommended:

- Use bypass capacitors on the power supply pins and place them as close to the device as possible.
- Use short trace lengths to avoid excessive loading.

11.2 Layout Example

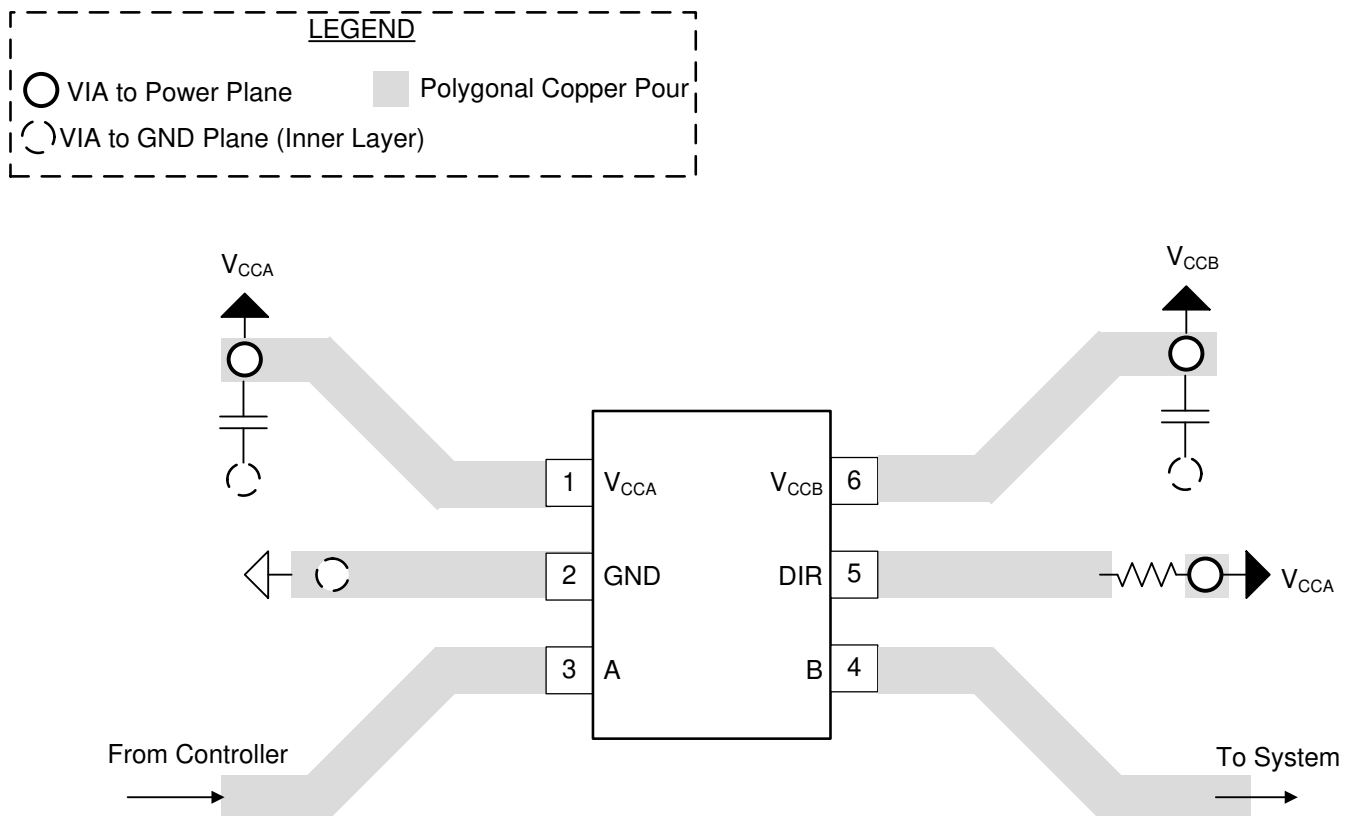

Figure 11-1. PCB Layout Example

12 Device and Documentation Support

12.1 Documentation Support

12.1.1 Related Documentation

For related documentation see the following:

- Texas Instruments, [Evaluate SN74AXC1T45DRL Using a Generic EVM](#) application report
- Texas Instruments, [System Considerations For Using Bus-hold Circuits To Avoid Floating Inputs](#) application report
- Texas Instruments, [Power Sequencing for the AXC Family of Devices](#) application report
- Texas Instruments, [Implications of Slow or Floating CMOS Inputs](#) application report

12.2 Receiving Notification of Documentation Updates

To receive notification of documentation updates, navigate to the device product folder on [ti.com](#). Click on [Subscribe to updates](#) to register and receive a weekly digest of any product information that has changed. For change details, review the revision history included in any revised document.

12.3 Support Resources

[TI E2E™ support forums](#) are an engineer's go-to source for fast, verified answers and design help — straight from the experts. Search existing answers or ask your own question to get the quick design help you need.

Linked content is provided "AS IS" by the respective contributors. They do not constitute TI specifications and do not necessarily reflect TI's views; see TI's [Terms of Use](#).

12.4 Trademarks

TI E2E™ is a trademark of Texas Instruments.

All trademarks are the property of their respective owners.

12.5 Electrostatic Discharge Caution



This integrated circuit can be damaged by ESD. Texas Instruments recommends that all integrated circuits be handled with appropriate precautions. Failure to observe proper handling and installation procedures can cause damage.

ESD damage can range from subtle performance degradation to complete device failure. Precision integrated circuits may be more susceptible to damage because very small parametric changes could cause the device not to meet its published specifications.

12.6 Glossary

[TI Glossary](#) This glossary lists and explains terms, acronyms, and definitions.

13 Mechanical, Packaging, and Orderable Information

The following pages include mechanical, packaging, and orderable information. This information is the most current data available for the designated devices. This data is subject to change without notice and revision of this document. For browser-based versions of this data sheet, refer to the left-hand navigation.

PACKAGING INFORMATION

Orderable Device	Status (1)	Package Type	Package Drawing	Pins	Package Qty	Eco Plan (2)	Lead finish/ Ball material (6)	MSL Peak Temp (3)	Op Temp (°C)	Device Marking (4/5)	Samples
SN74AXCH1T45DBVR	ACTIVE	SOT-23	DBV	6	3000	RoHS & Green	NIPDAU SN	Level-1-260C-UNLIM	-40 to 125	1PNL	Samples
SN74AXCH1T45DCKR	ACTIVE	SC70	DCK	6	3000	RoHS & Green	SN	Level-1-260C-UNLIM	-40 to 125	1CC	Samples
SN74AXCH1T45DRY2	ACTIVE	SON	DRY	6	5000	RoHS & Green	NIPDAU	Level-1-260C-UNLIM	-40 to 125	IR	Samples
SN74AXCH1T45DRYR	ACTIVE	SON	DRY	6	5000	RoHS & Green	NIPDAU	Level-1-260C-UNLIM	-40 to 125	II	Samples
SN74AXCH1T45DTQR	ACTIVE	X2SON	DTQ	6	3000	RoHS & Green	NIPDAU	Level-1-260C-UNLIM	-40 to 125	DM	Samples

(1) The marketing status values are defined as follows:

ACTIVE: Product device recommended for new designs.

LIFEBUY: TI has announced that the device will be discontinued, and a lifetime-buy period is in effect.

NRND: Not recommended for new designs. Device is in production to support existing customers, but TI does not recommend using this part in a new design.

PREVIEW: Device has been announced but is not in production. Samples may or may not be available.

OBSELETE: TI has discontinued the production of the device.

(2) **RoHS:** TI defines "RoHS" to mean semiconductor products that are compliant with the current EU RoHS requirements for all 10 RoHS substances, including the requirement that RoHS substance do not exceed 0.1% by weight in homogeneous materials. Where designed to be soldered at high temperatures, "RoHS" products are suitable for use in specified lead-free processes. TI may reference these types of products as "Pb-Free".

RoHS Exempt: TI defines "RoHS Exempt" to mean products that contain lead but are compliant with EU RoHS pursuant to a specific EU RoHS exemption.

Green: TI defines "Green" to mean the content of Chlorine (Cl) and Bromine (Br) based flame retardants meet JS709B low halogen requirements of <=1000ppm threshold. Antimony trioxide based flame retardants must also meet the <=1000ppm threshold requirement.

(3) MSL, Peak Temp. - The Moisture Sensitivity Level rating according to the JEDEC industry standard classifications, and peak solder temperature.

(4) There may be additional marking, which relates to the logo, the lot trace code information, or the environmental category on the device.

(5) Multiple Device Markings will be inside parentheses. Only one Device Marking contained in parentheses and separated by a "~" will appear on a device. If a line is indented then it is a continuation of the previous line and the two combined represent the entire Device Marking for that device.

(6) Lead finish/Ball material - Orderable Devices may have multiple material finish options. Finish options are separated by a vertical ruled line. Lead finish/Ball material values may wrap to two lines if the finish value exceeds the maximum column width.

Important Information and Disclaimer: The information provided on this page represents TI's knowledge and belief as of the date that it is provided. TI bases its knowledge and belief on information provided by third parties, and makes no representation or warranty as to the accuracy of such information. Efforts are underway to better integrate information from third parties. TI has taken and continues to take reasonable steps to provide representative and accurate information but may not have conducted destructive testing or chemical analysis on incoming materials and chemicals. TI and TI suppliers consider certain information to be proprietary, and thus CAS numbers and other limited information may not be available for release.

In no event shall TI's liability arising out of such information exceed the total purchase price of the TI part(s) at issue in this document sold by TI to Customer on an annual basis.

TAPE AND REEL INFORMATION

QUADRANT ASSIGNMENTS FOR PIN 1 ORIENTATION IN TAPE

*All dimensions are nominal

Device	Package Type	Package Drawing	Pins	SPQ	Reel Diameter (mm)	Reel Width W1 (mm)	A0 (mm)	B0 (mm)	K0 (mm)	P1 (mm)	W (mm)	Pin1 Quadrant
SN74AXCH1T45DBVR	SOT-23	DBV	6	3000	180.0	8.4	3.2	3.2	1.4	4.0	8.0	Q3
SN74AXCH1T45DCKR	SC70	DCK	6	3000	178.0	9.0	2.4	2.5	1.2	4.0	8.0	Q3
SN74AXCH1T45DRY2	SON	DRY	6	5000	180.0	9.5	1.6	1.15	0.68	4.0	8.0	Q3
SN74AXCH1T45DRYR	SON	DRY	6	5000	180.0	9.5	1.2	1.65	0.7	4.0	8.0	Q1
SN74AXCH1T45DTQR	X2SON	DTQ	6	3000	180.0	9.5	0.94	1.13	0.5	2.0	8.0	Q2

TAPE AND REEL BOX DIMENSIONS

*All dimensions are nominal

Device	Package Type	Package Drawing	Pins	SPQ	Length (mm)	Width (mm)	Height (mm)
SN74AXCH1T45DBVR	SOT-23	DBV	6	3000	210.0	185.0	35.0
SN74AXCH1T45DCKR	SC70	DCK	6	3000	180.0	180.0	18.0
SN74AXCH1T45DRY2	SON	DRY	6	5000	189.0	185.0	36.0
SN74AXCH1T45DRYR	SON	DRY	6	5000	189.0	185.0	36.0
SN74AXCH1T45DTQR	X2SON	DTQ	6	3000	189.0	185.0	36.0

EXAMPLE BOARD LAYOUT

DBV0006A

SOT-23 - 1.45 mm max height

SMALL OUTLINE TRANSISTOR

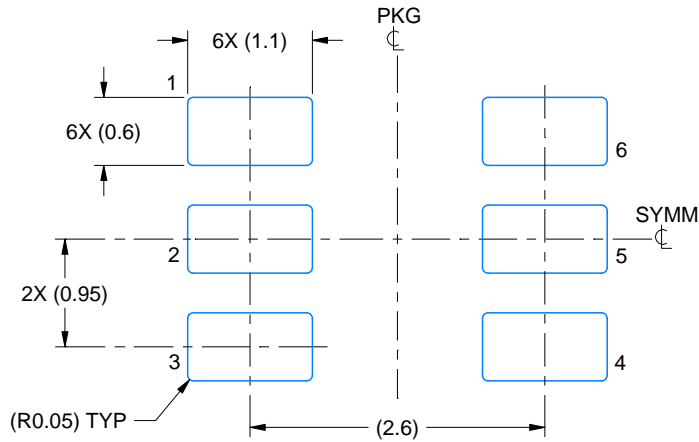

LAND PATTERN EXAMPLE
EXPOSED METAL SHOWN
SCALE:15X

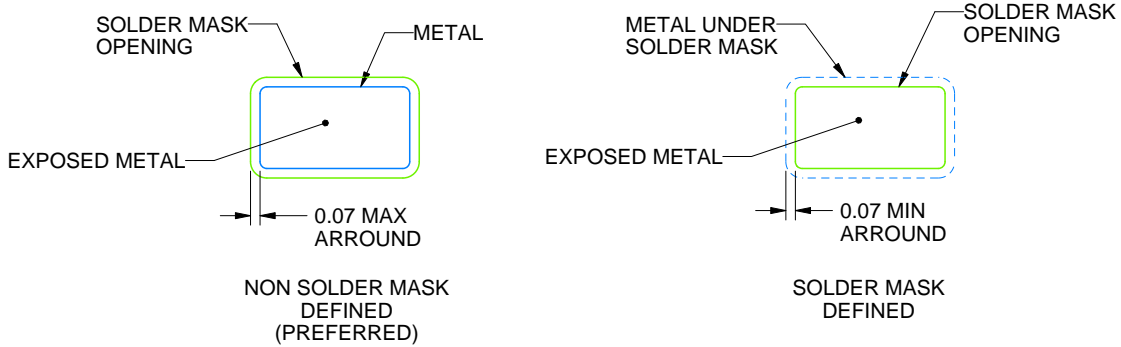

SOLDER MASK DETAILS

4214840/F 05/2024

NOTES: (continued)

6. Publication IPC-7351 may have alternate designs.

7. Solder mask tolerances between and around signal pads can vary based on board fabrication site.

EXAMPLE STENCIL DESIGN

DBV0006A

SOT-23 - 1.45 mm max height

SMALL OUTLINE TRANSISTOR

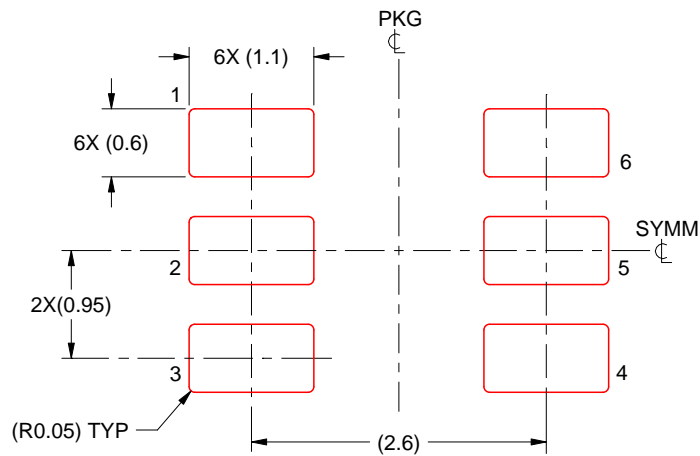

SOLDER PASTE EXAMPLE
BASED ON 0.125 mm THICK STENCIL
SCALE:15X

4214840/F 05/2024

NOTES: (continued)

8. Laser cutting apertures with trapezoidal walls and rounded corners may offer better paste release. IPC-7525 may have alternate design recommendations.
9. Board assembly site may have different recommendations for stencil design.

DCK0006A



PACKAGE OUTLINE

SOT - 1.1 max height

SMALL OUTLINE TRANSISTOR

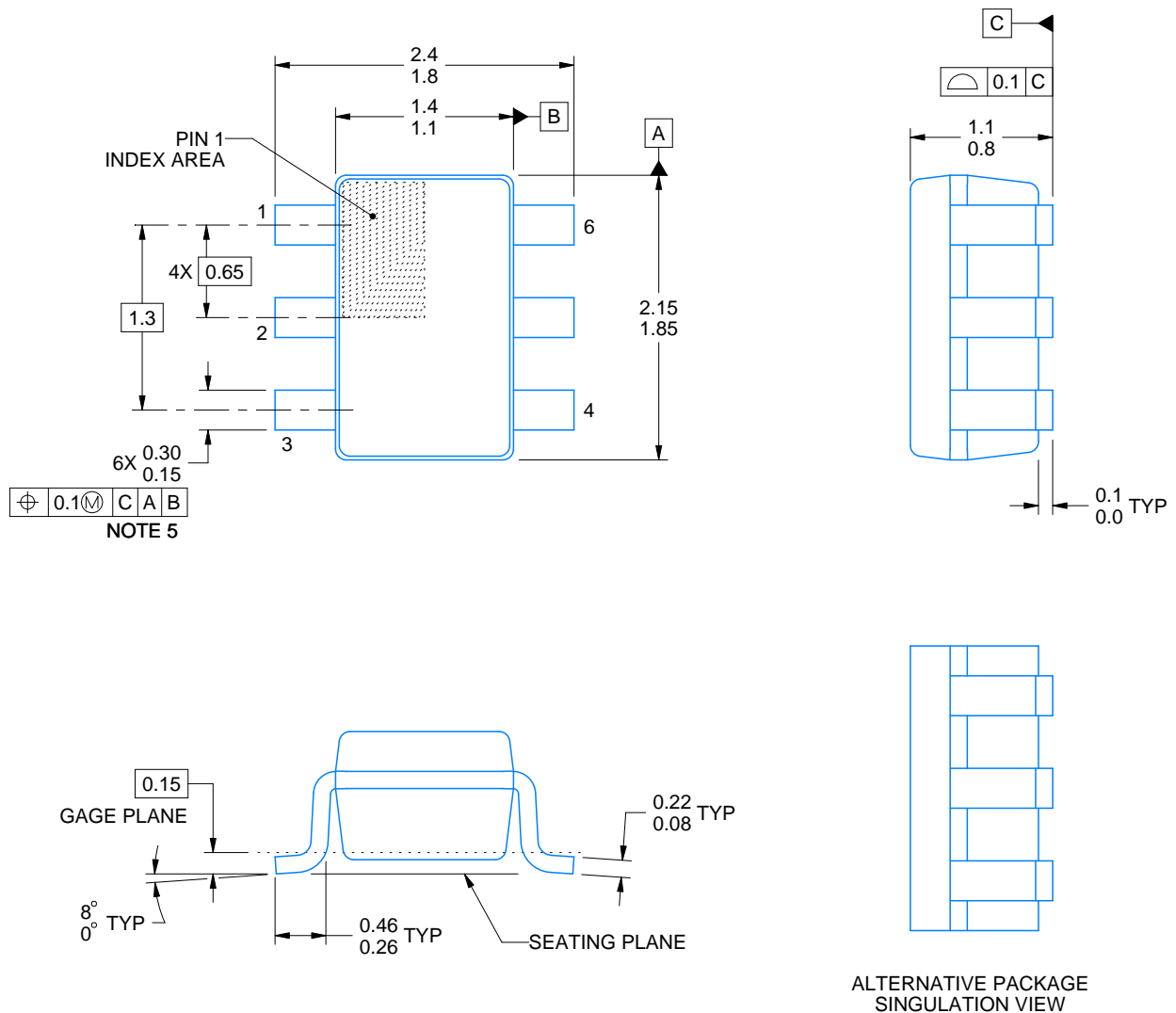

4214835/B 04/2024

NOTES:

1. All linear dimensions are in millimeters. Any dimensions in parenthesis are for reference only. Dimensioning and tolerancing per ASME Y14.5M.
2. This drawing is subject to change without notice.
3. Body dimensions do not include mold flash or protrusion. Mold flash and protrusion shall not exceed 0.15 per side.
4. Falls within JEDEC MO-203 variation AB.

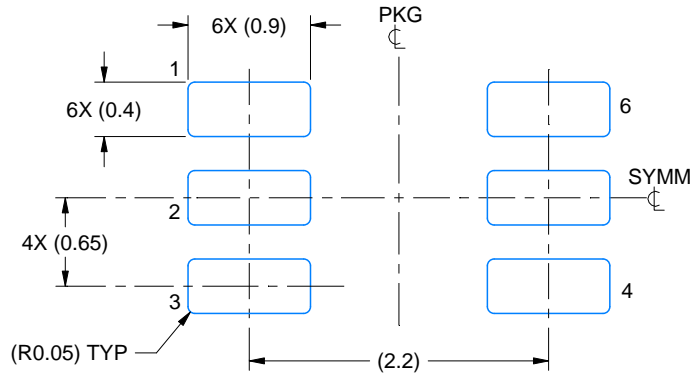

LAND PATTERN EXAMPLE
EXPOSED METAL SHOWN
SCALE:18X

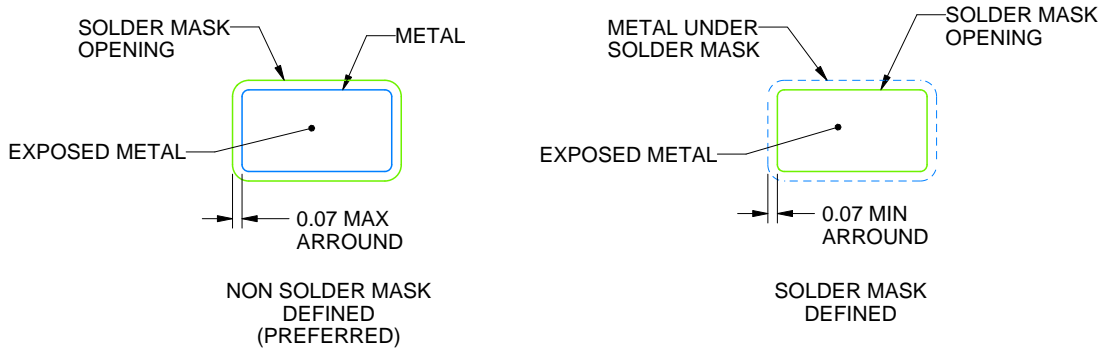

SOLDER MASK DETAILS

4214835/B 04/2024

NOTES: (continued)

5. Publication IPC-7351 may have alternate designs.
6. Solder mask tolerances between and around signal pads can vary based on board fabrication site.



SOLDER PASTE EXAMPLE
BASED ON 0.125 THICK STENCIL
SCALE:18X

4214835/B 04/2024

NOTES: (continued)

7. Laser cutting apertures with trapezoidal walls and rounded corners may offer better paste release. IPC-7525 may have alternate design recommendations.
8. Board assembly site may have different recommendations for stencil design.

GENERIC PACKAGE VIEW

DRY 6

USON - 0.6 mm max height

PLASTIC SMALL OUTLINE - NO LEAD



Images above are just a representation of the package family, actual package may vary.
Refer to the product data sheet for package details.

4207181/G

DRY0006A

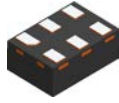

PACKAGE OUTLINE

USON - 0.6 mm max height

PLASTIC SMALL OUTLINE - NO LEAD



4222894/A 01/2018

NOTES:

1. All linear dimensions are in millimeters. Any dimensions in parenthesis are for reference only. Dimensioning and tolerancing per ASME Y14.5M.
2. This drawing is subject to change without notice.

EXAMPLE BOARD LAYOUT

DRY0006A

USON - 0.6 mm max height

PLASTIC SMALL OUTLINE - NO LEAD



LAND PATTERN EXAMPLE
1:1 RATIO WITH PKG SOLDER PADS
EXPOSED METAL SHOWN
SCALE:40X



SOLDER MASK DETAILS

4222894/A 01/2018

NOTES: (continued)

3. For more information, see QFN/SON PCB application report in literature No. SLUA271 (www.ti.com/lit/sluea271).

EXAMPLE STENCIL DESIGN

DRY0006A

USON - 0.6 mm max height

PLASTIC SMALL OUTLINE - NO LEAD



SOLDER PASTE EXAMPLE
BASED ON 0.075 - 0.1 mm THICK STENCIL
SCALE:40X

4222894/A 01/2018

NOTES: (continued)

4. Laser cutting apertures with trapezoidal walls and rounded corners may offer better paste release. IPC-7525 may have alternate design recommendations.

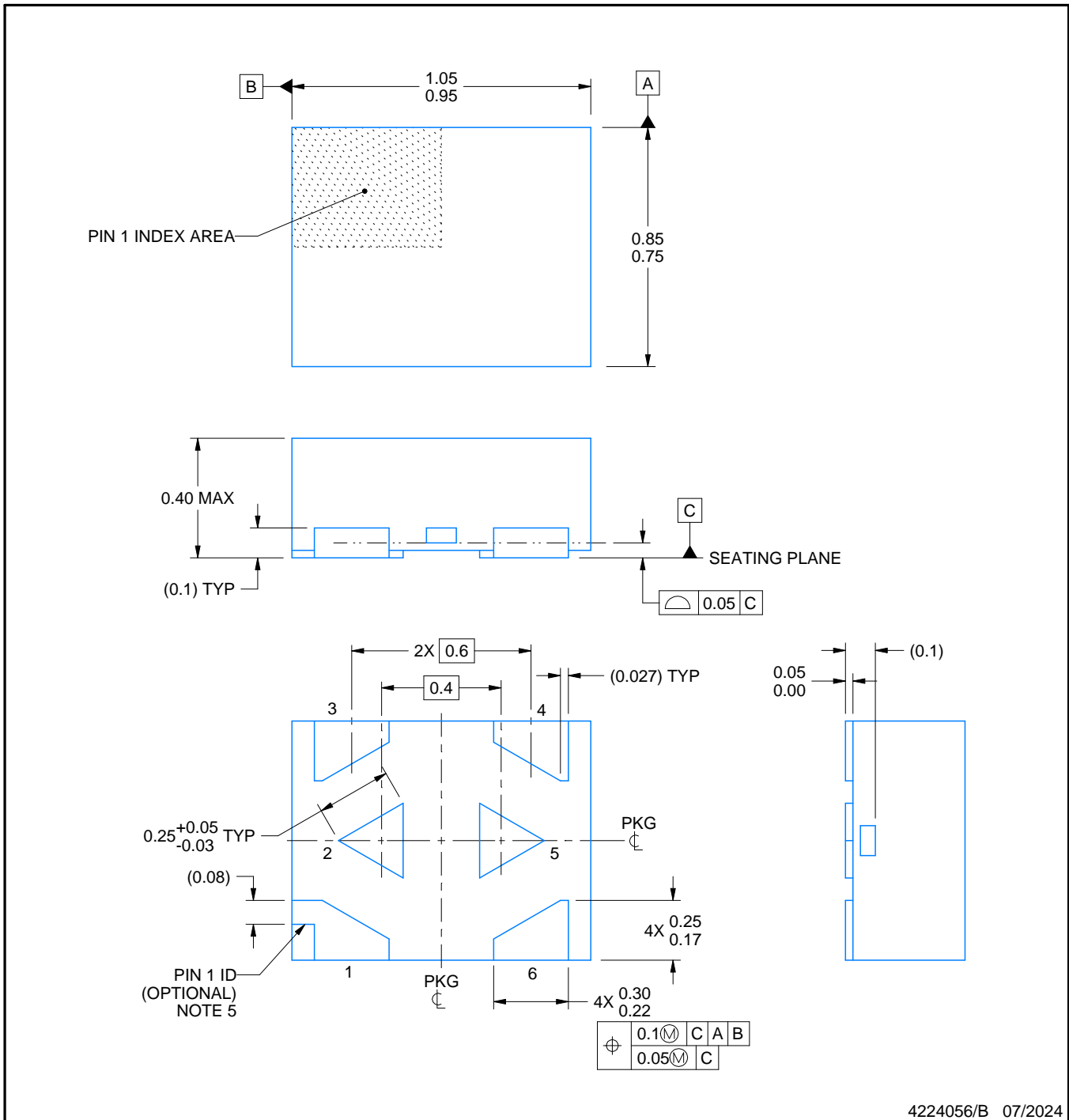

NOTES:

1. All linear dimensions are in millimeters. Any dimensions in parenthesis are for reference only. Dimensioning and tolerancing per ASME Y14.5M.
2. This drawing is subject to change without notice.
3. The package thermal pads must be soldered to the printed circuit board for optimal thermal and mechanical performance.
4. The size and shape of this feature may vary.
5. Features may not exist. Recommend use of pin 1 marking on top of package for orientation purposes.

EXAMPLE BOARD LAYOUT

DTQ0006A

X2SON - 0.4 mm max height

PLASTIC SMALL OUTLINE - NO LEAD

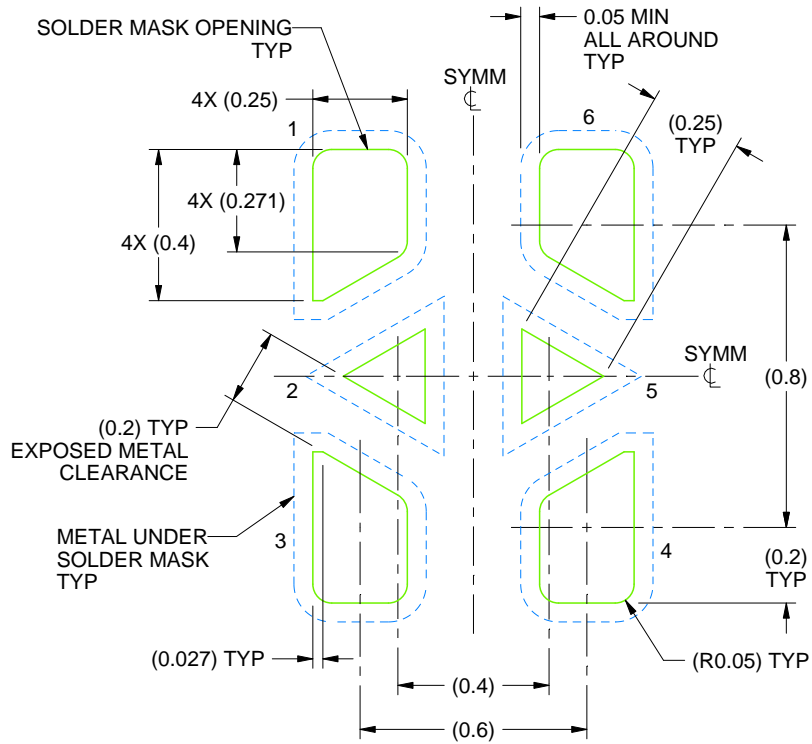

LAND PATTERN EXAMPLE
SOLDER MASK DEFINED
SCALE:50X

4224056/B 07/2024

NOTES: (continued)

6. This package is designed to be soldered to a thermal pads on the board. For more information, see Texas Instruments literature number SLUA271 (www.ti.com/lit/slua271).
7. Vias are optional depending on application, refer to device data sheet. If some or all are implemented, recommended via locations are shown.

EXAMPLE STENCIL DESIGN

DTQ0006A

X2SON - 0.4 mm max height

PLASTIC SMALL OUTLINE - NO LEAD

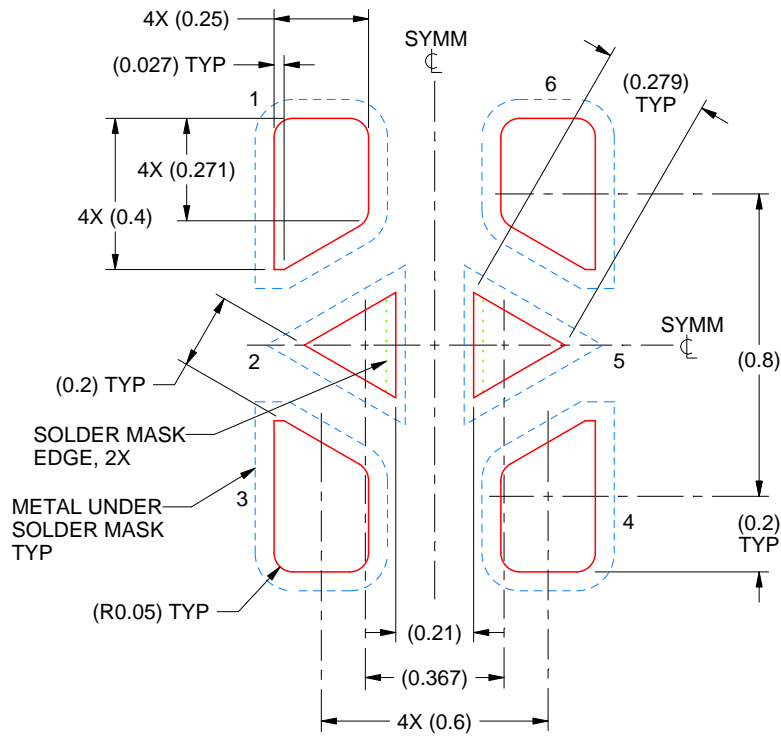

SOLDER PASTE EXAMPLE
BASED ON 0.07 mm THICK STENCIL

PRINTED SOLDER COVERAGE BY AREA UNDER PACKAGE
SCALE:50X

4224056/B 07/2024

NOTES: (continued)

8. Laser cutting apertures with trapezoidal walls and rounded corners may offer better paste release. IPC-7525 may have alternate design recommendations.

IMPORTANT NOTICE AND DISCLAIMER

TI PROVIDES TECHNICAL AND RELIABILITY DATA (INCLUDING DATA SHEETS), DESIGN RESOURCES (INCLUDING REFERENCE DESIGNS), APPLICATION OR OTHER DESIGN ADVICE, WEB TOOLS, SAFETY INFORMATION, AND OTHER RESOURCES "AS IS" AND WITH ALL FAULTS, AND DISCLAIMS ALL WARRANTIES, EXPRESS AND IMPLIED, INCLUDING WITHOUT LIMITATION ANY IMPLIED WARRANTIES OF MERCHANTABILITY, FITNESS FOR A PARTICULAR PURPOSE OR NON-INFRINGEMENT OF THIRD PARTY INTELLECTUAL PROPERTY RIGHTS.

These resources are intended for skilled developers designing with TI products. You are solely responsible for (1) selecting the appropriate TI products for your application, (2) designing, validating and testing your application, and (3) ensuring your application meets applicable standards, and any other safety, security, regulatory or other requirements.

These resources are subject to change without notice. TI grants you permission to use these resources only for development of an application that uses the TI products described in the resource. Other reproduction and display of these resources is prohibited. No license is granted to any other TI intellectual property right or to any third party intellectual property right. TI disclaims responsibility for, and you will fully indemnify TI and its representatives against, any claims, damages, costs, losses, and liabilities arising out of your use of these resources.

TI's products are provided subject to [TI's Terms of Sale](#) or other applicable terms available either on [ti.com](https://www.ti.com) or provided in conjunction with such TI products. TI's provision of these resources does not expand or otherwise alter TI's applicable warranties or warranty disclaimers for TI products.

TI objects to and rejects any additional or different terms you may have proposed.

Mailing Address: Texas Instruments, Post Office Box 655303, Dallas, Texas 75265
Copyright © 2024, Texas Instruments Incorporated