

TLV431x-Q1 Low-Voltage Adjustable Precision Shunt Regulator

1 Features

- Qualified for automotive applications
- AEC-Q100 qualified with the following results:
 - Device temperature grade 1: -40°C to 125°C ambient operating temperature range
- Low-voltage operation, $V_{\text{REF}} = 1.24\text{V}$
- Adjustable output voltage, $V_{\text{O}} = V_{\text{REF}}$ to 6V
- Reference voltage tolerances at 25°C
 - 0.5% for TLV431B
 - 1% for TLV431A
- Typical temperature drift
 - 11mV (-40°C to 125°C)
- Low operational cathode current, $80\mu\text{A}$ typical
- 0.25Ω Typical output impedance
- See [TLVH431](#) and [TLVH432](#) for:
 - Wider V_{KA} (1.24V to 18V) and I_{K} (80mA)
 - Multiple pinouts for SOT-23-3 and SOT-89 packages

2 Applications

- [Adjustable voltage and current referencing](#)
- [Secondary side regulation in flyback SMPSs](#)
- [Zener replacement](#)
- [Voltage monitoring](#)
- [Comparator with integrated reference](#)

3 Description

The TLV431 device is a low-voltage 3-terminal adjustable voltage reference with specified thermal stability over applicable industrial and commercial temperature ranges. Output voltage can be set to 1.24V on stand alone mode or any value between V_{REF} (1.24V) and 6V with two external resistors (see [Figure 6-2](#)). These devices operate from a lower voltage (1.24V) than the widely used TL431 and TL1431 shunt-regulator references.

When used with an optocoupler, the TLV431 device is a voltage reference in isolated feedback circuits designed for 3V to 3.3V switching-mode power supplies. These devices have a typical output impedance of 0.25Ω . Active output circuitry provides a very sharp turn-on characteristic, making them excellent replacements for low-voltage Zener diodes in many applications, including on-board regulation and adjustable power supplies.

Device Information

PART NUMBER	PACKAGE (PIN) ⁽¹⁾	BODY SIZE (NOM) ⁽²⁾
TLV431x-Q1	SOT-23 (3)	2.90mm x 1.30mm
	SOT-23 (5)	2.90mm x 1.60mm

- (1) For all available packages, see the orderable addendum at the end of the data sheet.
- (2) The package size (length × width) is a nominal value and includes pins, where applicable.

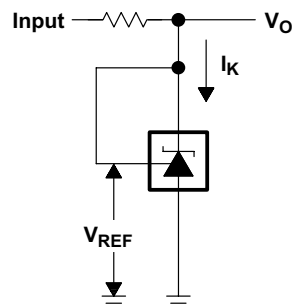

Simplified Schematic



Table of Contents

1 Features	1	7.3 Feature Description.....	16
2 Applications	1	7.4 Device Functional Modes.....	17
3 Description	1	8 Applications and Implementation	18
4 Pin Configuration and Functions	3	8.1 Application Information.....	18
Pin Functions.....	3	8.2 Typical Applications.....	19
5 Specifications	4	8.3 Power Supply Recommendations.....	22
5.1 Absolute Maximum Ratings.....	4	8.4 Layout.....	22
5.2 ESD Ratings.....	4	9 Device and Documentation Support	24
5.3 Thermal Information.....	4	9.1 Receiving Notification of Documentation Updates....	24
5.4 Recommended Operating Conditions.....	4	9.2 Support Resources.....	24
5.5 Electrical Characteristics for TLV431A-Q1.....	5	9.3 Trademarks.....	24
5.6 Electrical Characteristics for TLV431B-Q1.....	6	9.4 Electrostatic Discharge Caution.....	24
5.7 Typical Characteristics.....	7	9.5 Glossary.....	24
6 Parameter Measurement Information	15	10 Revision History	24
7 Detailed Description	16	11 Mechanical, Packaging, and Orderable Information	24
7.1 Overview.....	16		
7.2 Functional Block Diagram.....	16		

4 Pin Configuration and Functions

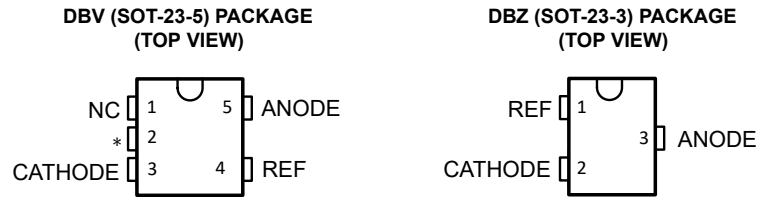

NC—No internal connection

* Pin 2 is attached to Substrate and must be connected to ANODE or left open.

Pin Functions

NAME	PIN		TYPE	DESCRIPTION
	DBZ	DBV		
CATHODE	2	3	I/O	Shunt Current/Voltage input
REF	1	4	I	Threshold relative to common anode
ANODE	3	5	O	Common pin, normally connected to ground
NC	—	1	I	No Internal Connection
*	—	2	I	Substrate Connection

5 Specifications

5.1 Absolute Maximum Ratings

over operating free-air temperature range (unless otherwise noted)⁽¹⁾

		MIN	MAX	UNIT
V_{KA}	Cathode voltage ⁽²⁾		7	V
I_K	Continuous cathode current range	-20	20	mA
I_{ref}	Reference current range	-0.05	3	mA
	Operating virtual junction temperature		150	°C
T_{stg}	Storage temperature range	-65	150	°C

- (1) Stresses beyond those listed under *Absolute Maximum Ratings* may cause permanent damage to the device. These are stress ratings only, and functional operation of the device at these or any other conditions beyond those indicated under [Section 5.4](#) is not implied. Exposure to absolute-maximum-rated conditions for extended periods may affect device reliability.
- (2) Voltage values are with respect to the anode terminal, unless otherwise noted.

5.2 ESD Ratings

		VALUE	UNIT
$V_{(ESD)}$	Electrostatic discharge	Human-body model (HBM), per AEC Q100-002 ⁽¹⁾	±2000
		Charged-device model (CDM), per AEC Q100-011	±1000

- (1) AEC Q100-002 indicates that HBM stressing shall be in accordance with the ANSI/ESDA/JEDEC JS-001 specification.

5.3 Thermal Information

THERMAL METRIC ⁽¹⁾	TLV431x		UNIT	
	DBV	DBZ		
	5 PINS	3 PINS		
$R_{\theta JA}$	Junction-to-ambient thermal resistance	206	206	°C/W
$R_{\theta JC(top)}$	Junction-to-case (top) thermal resistance	131	76	

- (1) For more information about traditional and new thermal metrics, see the [Semiconductor and IC Package Thermal Metrics](#) application report.

5.4 Recommended Operating Conditions

over operating free-air temperature range (unless otherwise noted)

		MIN	MAX	UNIT
V_{KA}	Cathode voltage	V_{REF}	6	V
I_K	Cathode current	0.1	15	mA
T_A	Operating free-air temperature range	-40	125	°C

5.5 Electrical Characteristics for TLV431A-Q1

at 25°C free-air temperature (unless otherwise noted)

PARAMETER	TEST CONDITIONS	TLV431AQ			UNIT
		MIN	TYP	MAX	
V _{REF} Reference voltage	V _{KA} = V _{REF} , I _K = 10mA	T _A = 25°C			V
		T _A = full range ⁽¹⁾ (see Figure 6-1)			
V _{REF(dev)}	V _{KA} = V _{REF} , I _K = 10mA ⁽¹⁾ (see Figure 6-1)		11	31	mV
$\frac{\Delta V_{REF}}{\Delta V_{KA}}$	V _{KA} = V _{REF} to 6V, I _K = 10mA (see Figure 6-2)		-1.5	-2.7	mV/V
I _{ref}	I _K = 10mA, R1 = 10kΩ, R2 = open (see Figure 6-2)		0.15	0.5	μA
I _{ref(dev)}	I _K = 10mA, R1 = 10kΩ, R2 = open ⁽¹⁾ (see Figure 6-2)		0.15	0.5	μA
I _{K(min)}	V _{KA} = V _{REF} (see Figure 6-1)		55	100	μA
I _{K(off)}	V _{REF} = 0, V _{KA} = 6V (see Figure 6-3)		0.001	0.1	μA
z _{KA}	V _{KA} = V _{REF} , f ≤ 1kHz, I _K = 0.1mA to 15mA (see Figure 6-1)		0.25	0.4	Ω

- (1) Full temperature range is -40°C to 125°C for TLV431X-Q1.
(2) The deviation parameters V_{REF(dev)} and I_{ref(dev)} are defined as the differences between the maximum and minimum values obtained over the rated temperature range. The average full-range temperature coefficient of the reference input voltage, αV_{REF}, is defined as:

$$|\alpha V_{REF}| \left(\frac{\text{ppm}}{^{\circ}\text{C}} \right) = \frac{\left(\frac{V_{REF(dev)}}{V_{REF}(T_A = 25^{\circ}\text{C})} \right) \times 10^6}{\Delta T_A}$$

where ΔT_A is the rated operating free-air temperature range of the device.

αV_{REF} can be positive or negative, depending on whether minimum V_{REF} or maximum V_{REF}, respectively, occurs at the lower temperature.

- (3) The dynamic impedance is defined as $|z_{ka}| = \frac{\Delta V_{KA}}{\Delta I_K}$

When the device is operating with two external resistors (see Figure 6-2), the total dynamic impedance of the circuit is defined as:

$$|z_{ka}|' = \frac{\Delta V}{\Delta I} \approx |z_{ka}| \times \left(1 + \frac{R1}{R2} \right)$$

5.6 Electrical Characteristics for TLV431B-Q1

at 25°C free-air temperature (unless otherwise noted)

PARAMETER	TEST CONDITIONS	TLV431BQ			UNIT
		MIN	TYP	MAX	
V _{REF}	Reference voltage V _{KA} = V _{REF} , I _K = 10mA	T _A = 25°C			V
		T _A = full range ⁽¹⁾ (see Figure 6-1)			
V _{REF(dev)}	V _{REF} deviation over full temperature range ⁽²⁾ V _{KA} = V _{REF} , I _K = 10mA ⁽¹⁾ (see Figure 6-1)		11	31	mV
$\frac{\Delta V_{REF}}{\Delta V_{KA}}$	Ratio of V _{REF} change in cathode voltage change V _{KA} = V _{REF} to 6V, I _K = 10mA (see Figure 6-2)		-1.5	-2.7	mV/V
I _{ref}	Reference terminal current I _K = 10mA, R1 = 10kΩ, R2 = open (see Figure 6-2)		0.1	0.5	μA
I _{ref(dev)}	I _{ref} deviation over full temperature range ⁽²⁾ I _K = 10mA, R1 = 10kΩ, R2 = open (see Figure 6-2)		0.15	0.5	μA
I _{K(min)}	Minimum cathode current for regulation V _{KA} = V _{REF} (see Figure 6-1)		55	100	μA
I _{K(off)}	Off-state cathode current V _{REF} = 0, V _{KA} = 6V (see Figure 6-3)		0.001	0.1	μA
z _{KA}	Dynamic impedance ⁽³⁾ V _{KA} = V _{REF} , f ≤ 1kHz, I _K = 0.1mA to 15mA (see Figure 6-1)		0.25	0.4	Ω

(1) Full temperature range is -40°C to 125°C for TLV431x-Q1.

(2) The deviation parameters V_{REF(dev)} and I_{ref(dev)} are defined as the differences between the maximum and minimum values obtained over the rated temperature range. The average full-range temperature coefficient of the reference input voltage, αV_{REF}, is defined as:

$$|\alpha V_{REF}| \left(\frac{\text{ppm}}{^{\circ}\text{C}} \right) = \frac{\left(\frac{V_{REF(dev)}}{V_{REF}(T_A = 25^{\circ}\text{C})} \right) \times 10^6}{\Delta T_A}$$

where ΔT_A is the rated operating free-air temperature range of the device.

αV_{REF} can be positive or negative, depending on whether minimum V_{REF} or maximum V_{REF}, respectively, occurs at the lower temperature.

(3) The dynamic impedance is defined as $|z_{ka}| = \frac{\Delta V_{KA}}{\Delta I_K}$

When the device is operating with two external resistors (see Figure 6-2), the total dynamic impedance of the circuit is defined as:

$$|z_{ka}|' = \frac{\Delta V}{\Delta I} \approx |z_{ka}| \times \left(1 + \frac{R1}{R2} \right)$$

5.7 Typical Characteristics

Operation of the device at these or any other conditions beyond those indicated in the [Section 5.4](#) table are not implied.

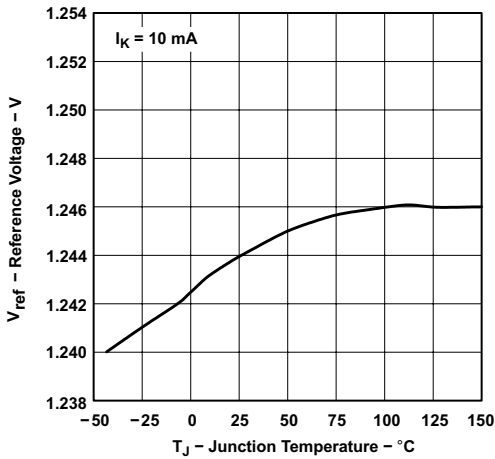

Figure 5-1. Reference Voltage vs Junction Temperature

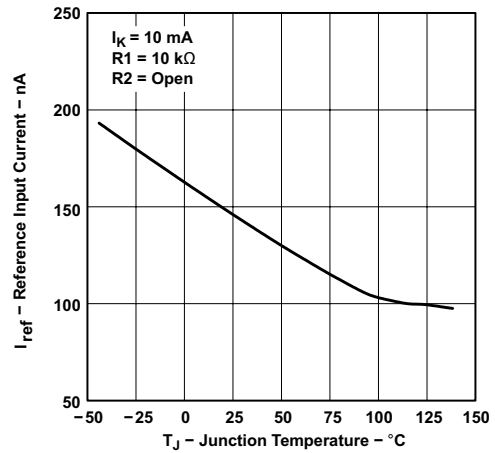

Figure 5-2. Reference Current vs Free-air Temperature (TLV431A)

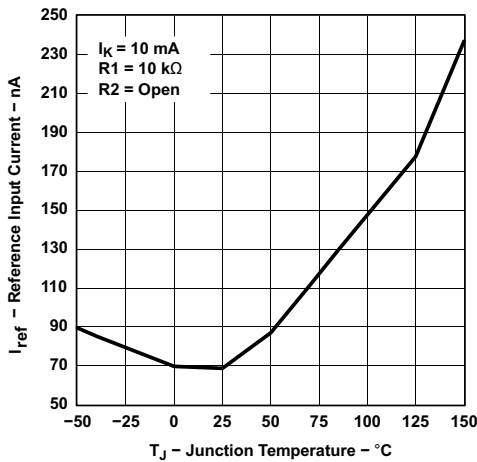

Figure 5-3. Reference Input Current vs Junction Temperature (for TLV431B)

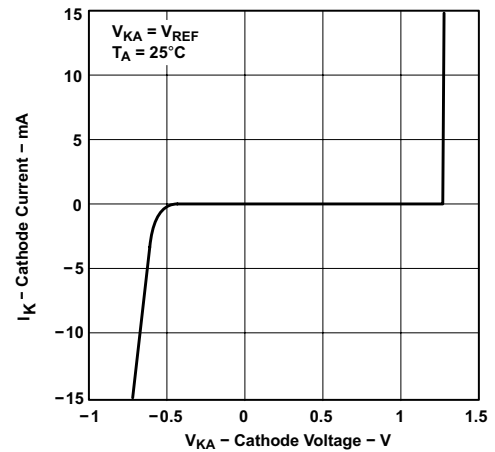

Figure 5-4. Cathode Current vs Cathode Voltage

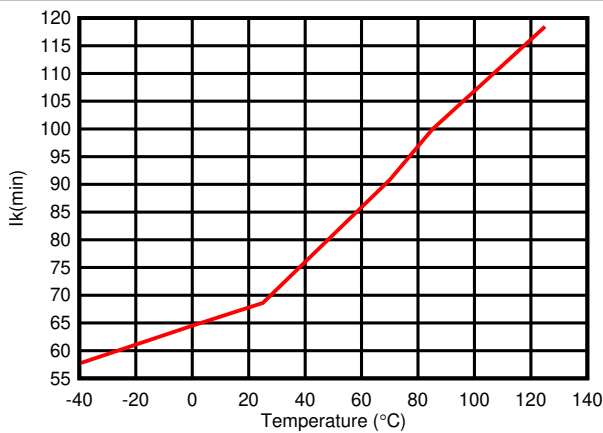

Figure 5-5. Minimum Cathode Current (µA) vs Temperature

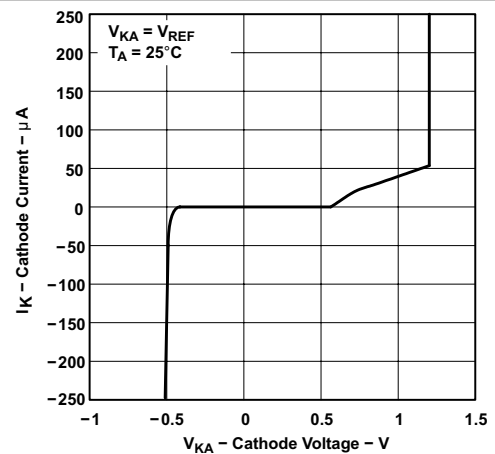

Figure 5-6. Cathode Current vs Cathode Voltage

5.7 Typical Characteristics (continued)

Operation of the device at these or any other conditions beyond those indicated in the [Section 5.4](#) table are not implied.

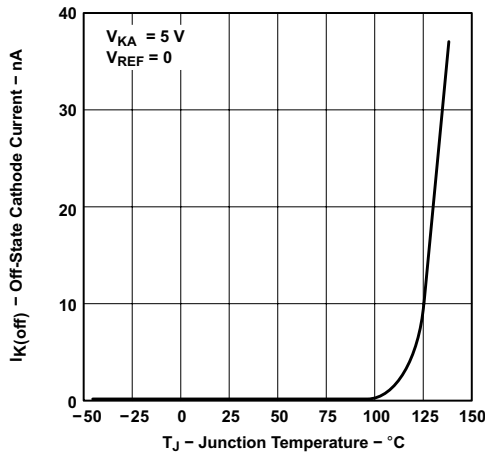

Figure 5-7. Off-State Cathode Current vs Junction Temperature for TLV431A

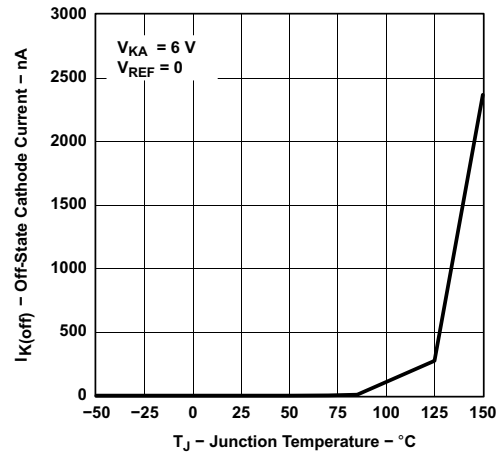

Figure 5-8. Off-State Cathode Current vs Junction Temperature for TLV431B

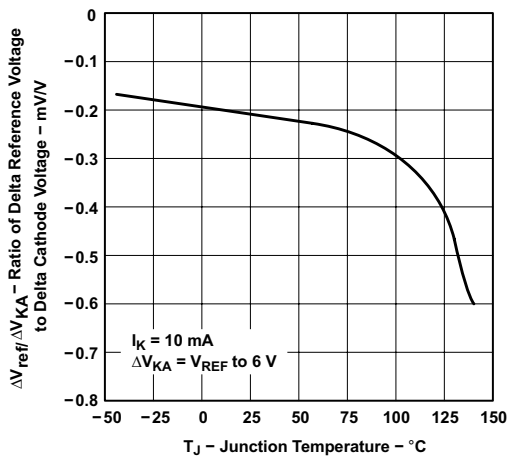

Figure 5-9. Ratio of Delta Reference Voltage to Delta Cathode Voltage vs Junction Temperature for TLV431A

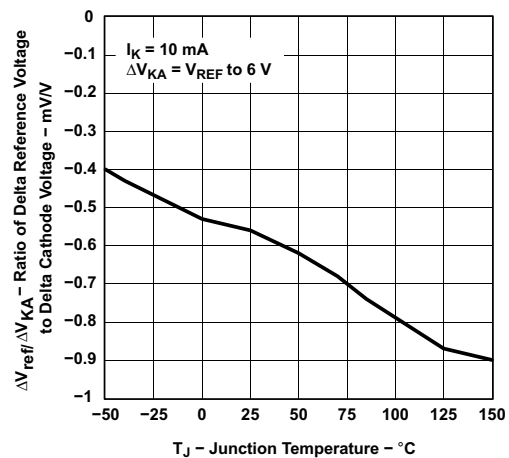
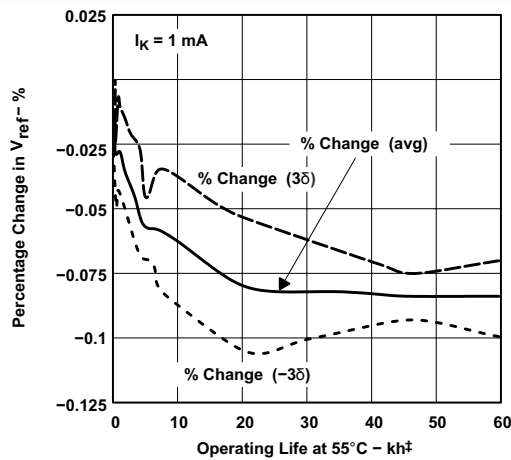

Figure 5-10. Ratio of Delta Reference Voltage to Delta Cathode Voltage vs Junction Temperature (for TLV431B)



† Extrapolated from life-test data taken at 125°C; the activation energy assumed is 0.7 eV.

Figure 5-11. Percentage Change in V_{REF} vs Operating Life at 55°C

5.7 Typical Characteristics (continued)

Operation of the device at these or any other conditions beyond those indicated in the [Section 5.4](#) table are not implied.

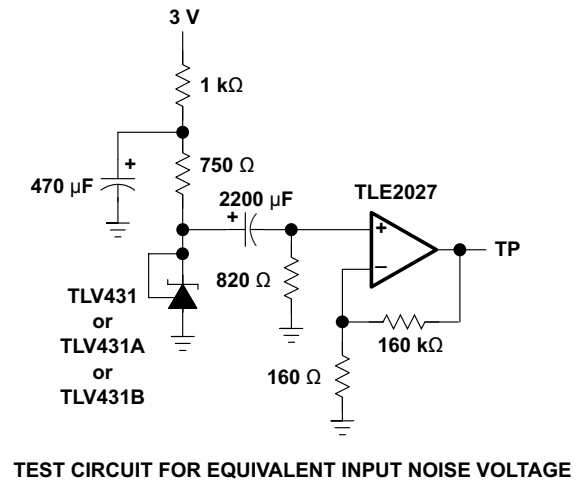
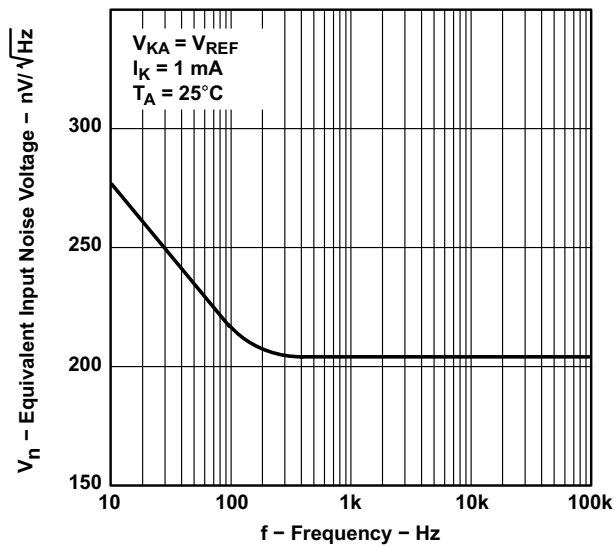

Figure 5-12. Equivalent Input Noise Voltage

5.7 Typical Characteristics (continued)

Operation of the device at these or any other conditions beyond those indicated in the [Section 5.4](#) table are not implied.

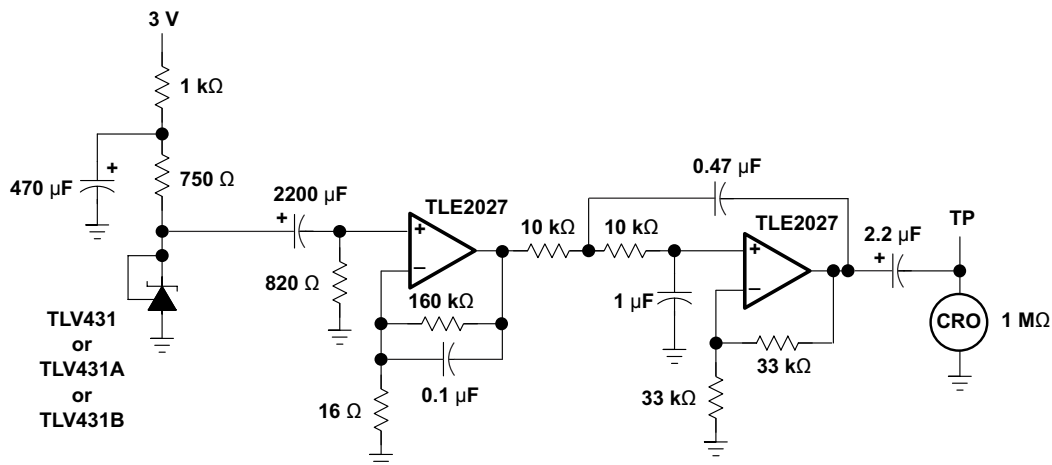
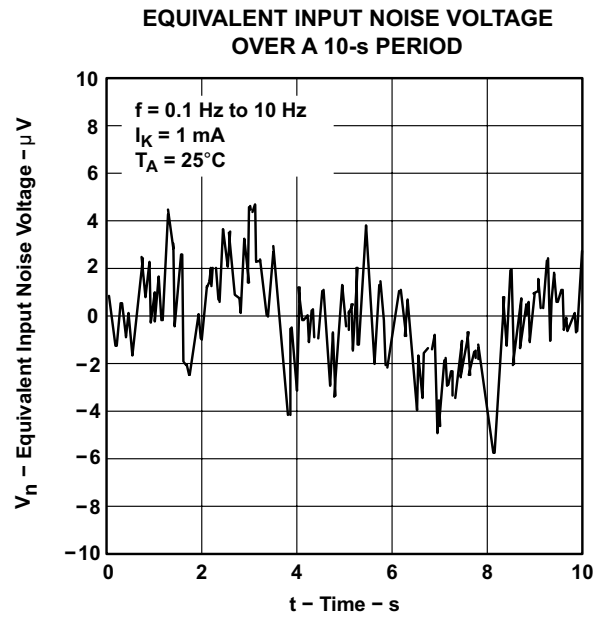

Figure 5-13. Equivalent Noise Voltage over a 10s Period

5.7 Typical Characteristics (continued)

Operation of the device at these or any other conditions beyond those indicated in the [Section 5.4](#) table are not implied.

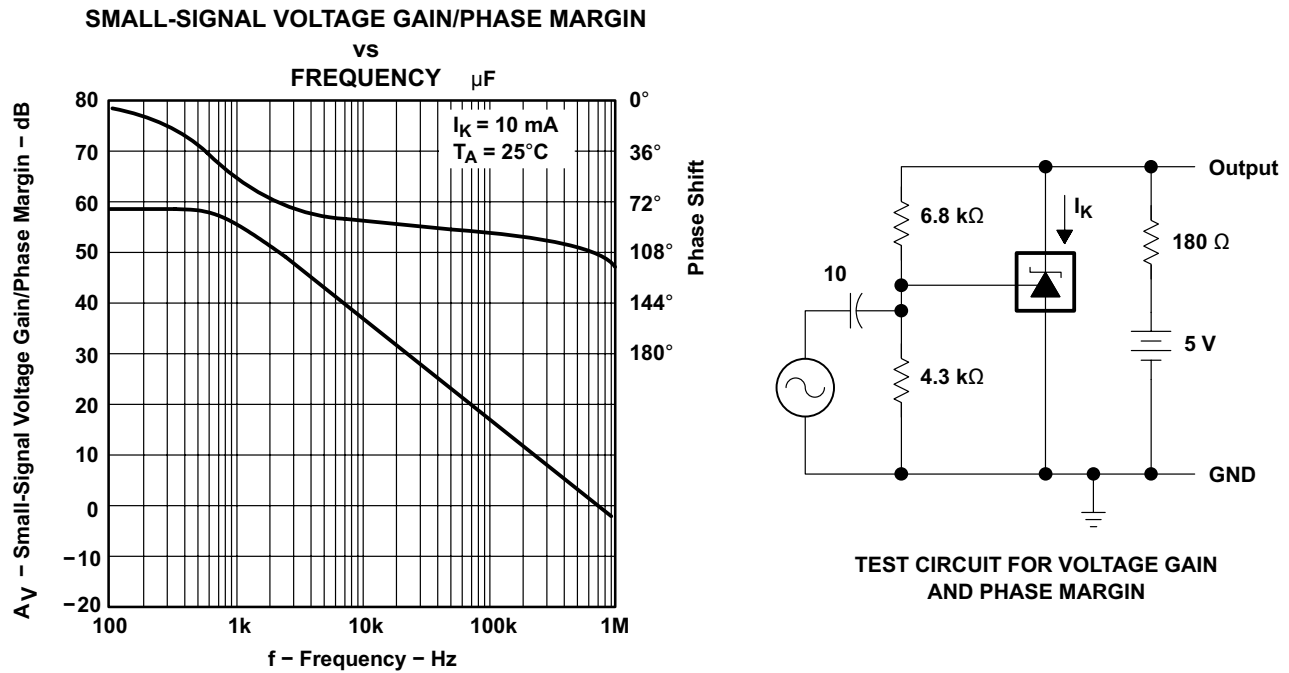

Figure 5-14. Voltage Gain and Phase Margin

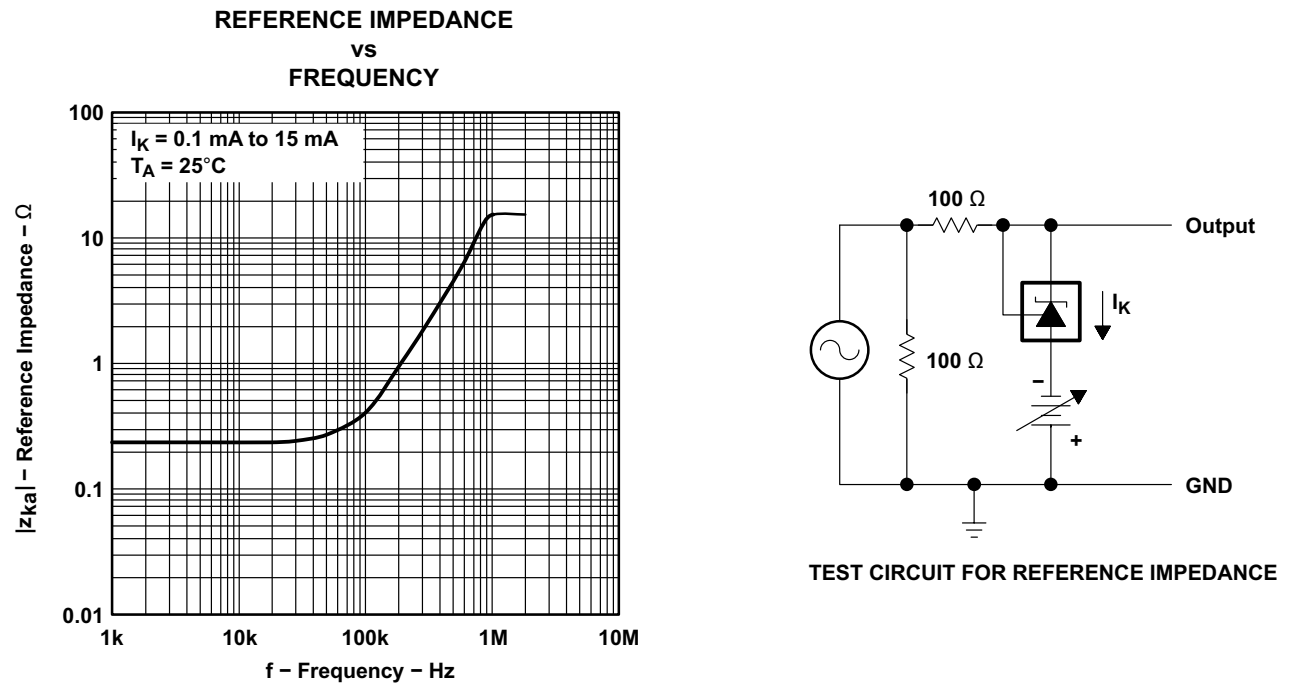

Figure 5-15. Reference Impedance vs Frequency

5.7 Typical Characteristics (continued)

Operation of the device at these or any other conditions beyond those indicated in the [Section 5.4](#) table are not implied.

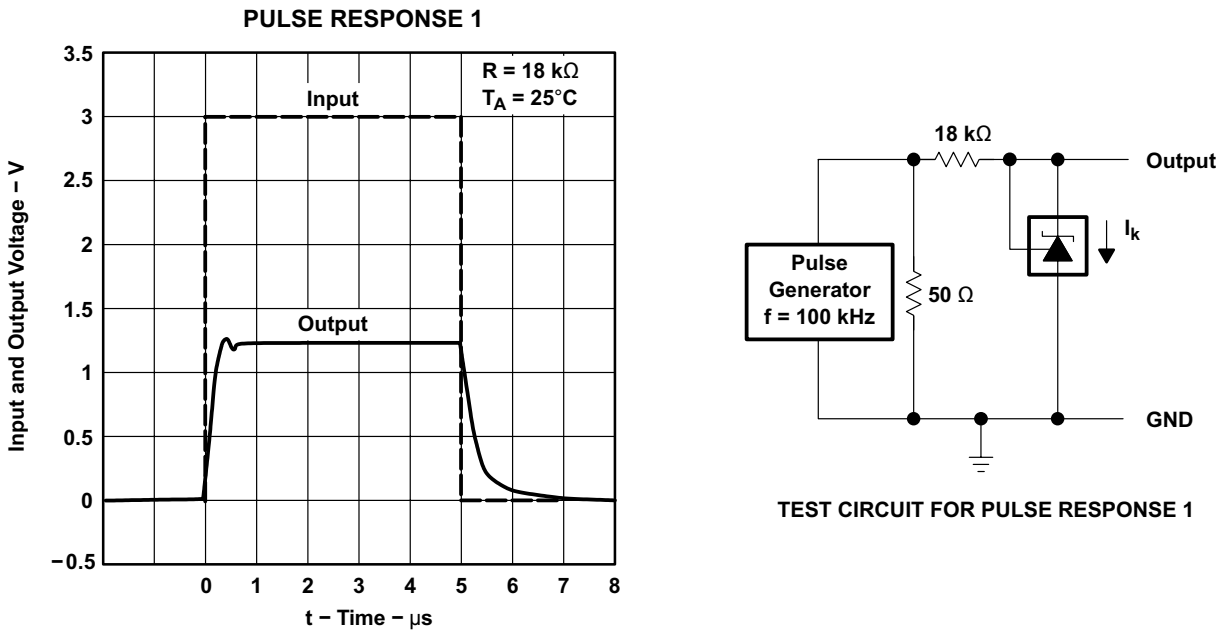

Figure 5-16. Pulse Response 1

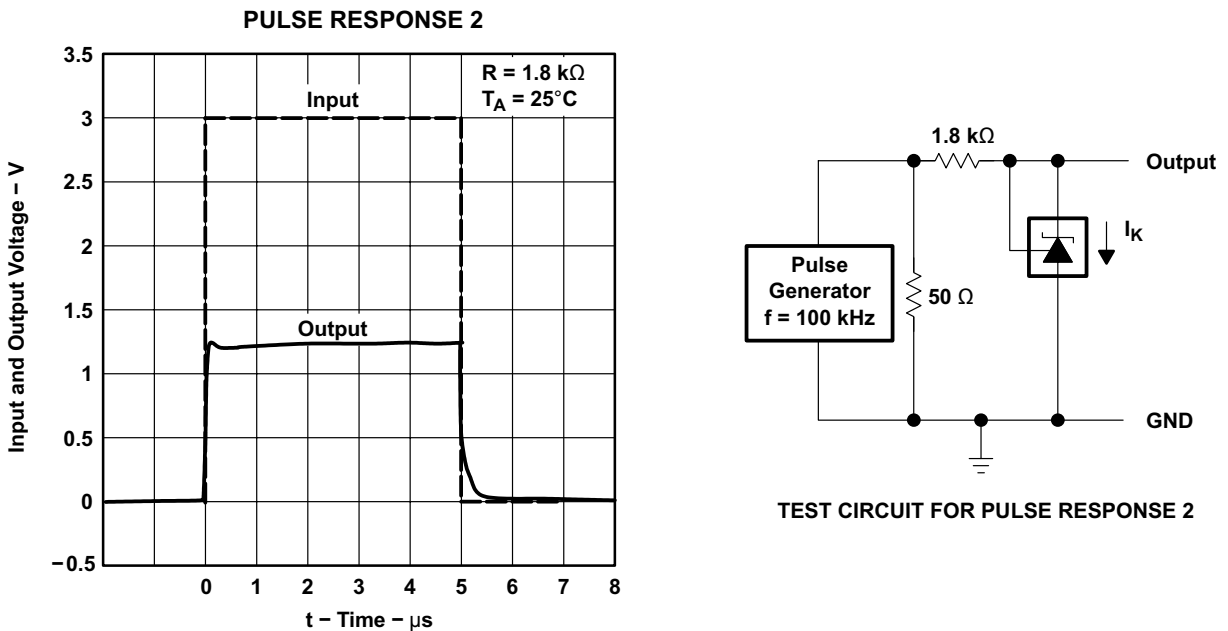
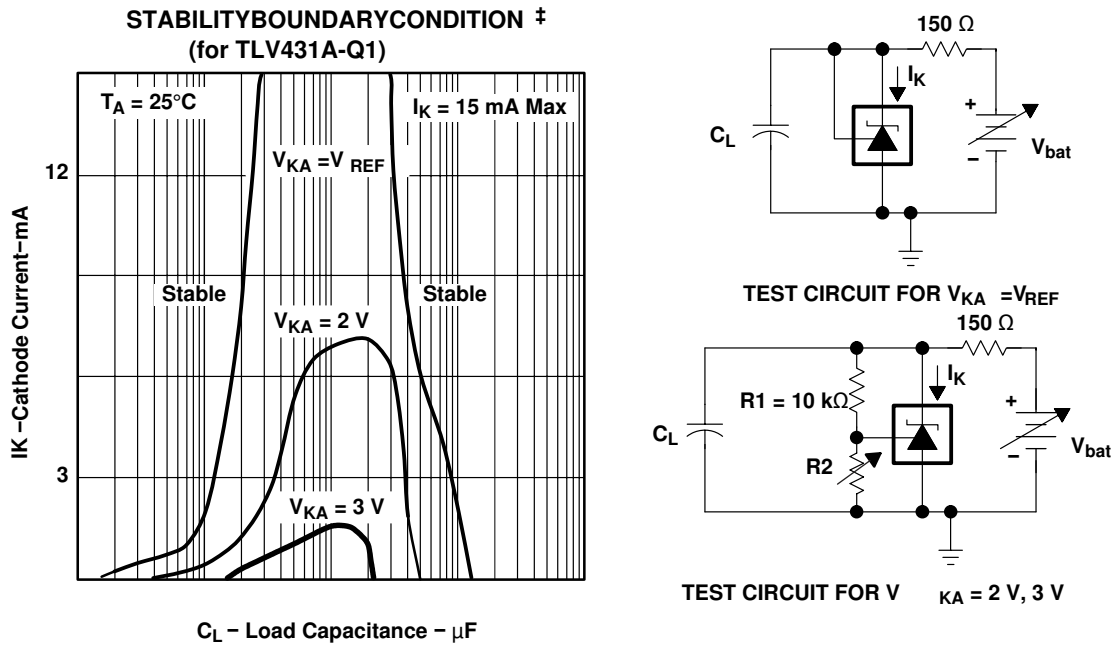

Figure 5-17. Pulse Response 2

5.7 Typical Characteristics (continued)

Operation of the device at these or any other conditions beyond those indicated in the [Section 5.4](#) table are not implied.



‡ The areas under the curves represent conditions that can cause the device to oscillate. For $V_{KA} = 2V$ and $3V$ curves, R_2 and V_{bat} were adjusted to establish the initial V_{KA} and I_K conditions with $C_L = 0$. V_{bat} and C_L then were adjusted to determine the ranges of stability.

Figure 5-18. Stability Boundary Conditions

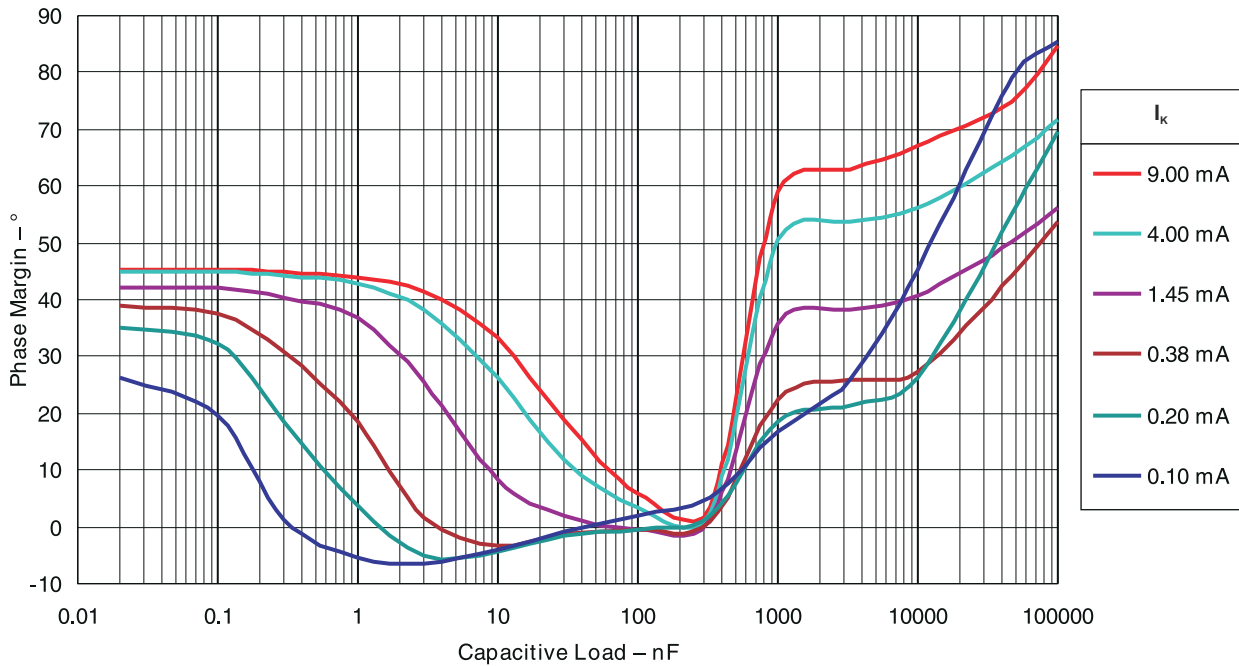

Figure 5-19. Phase Margin vs Capacitive Load $V_{KA} = V_{REF}$ (1.25 V), $T_A = 25^\circ\text{C}$ (For TLV431B-Q1)

5.7 Typical Characteristics (continued)

Operation of the device at these or any other conditions beyond those indicated in the [Section 5.4](#) table are not implied.

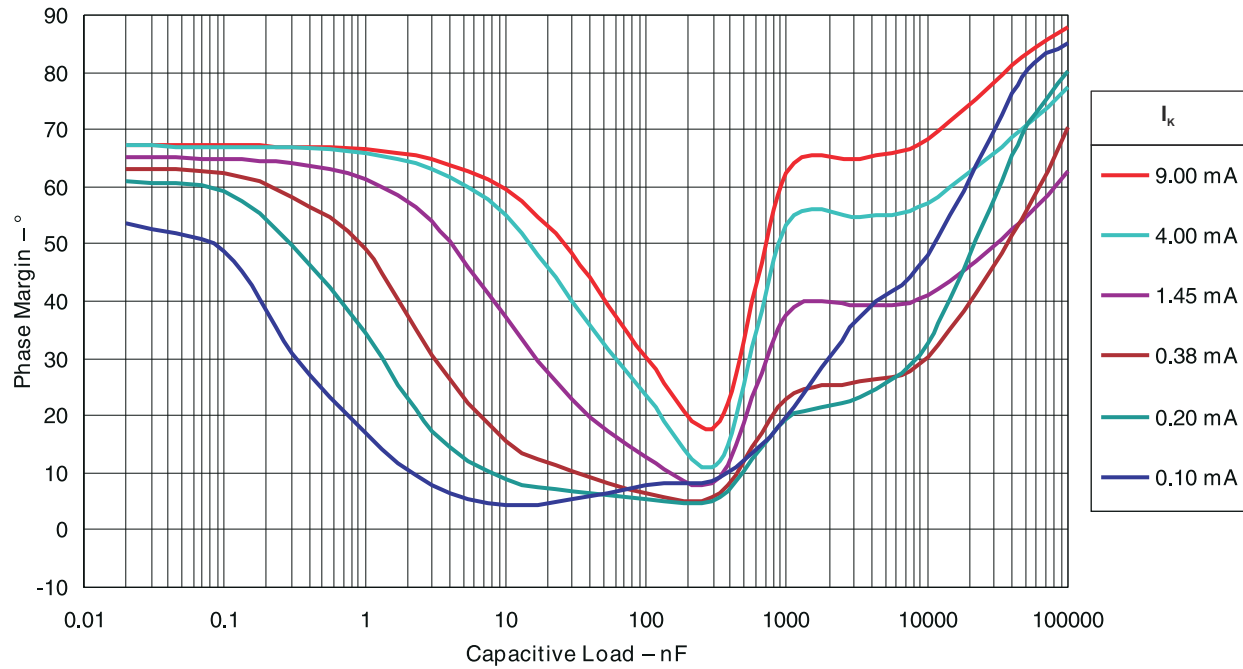

Figure 5-20. Phase Margin vs Capacitive Load $V_{KA} = 2.50V$, $T_A = 25^\circ C$ (For TLV431B-Q1)

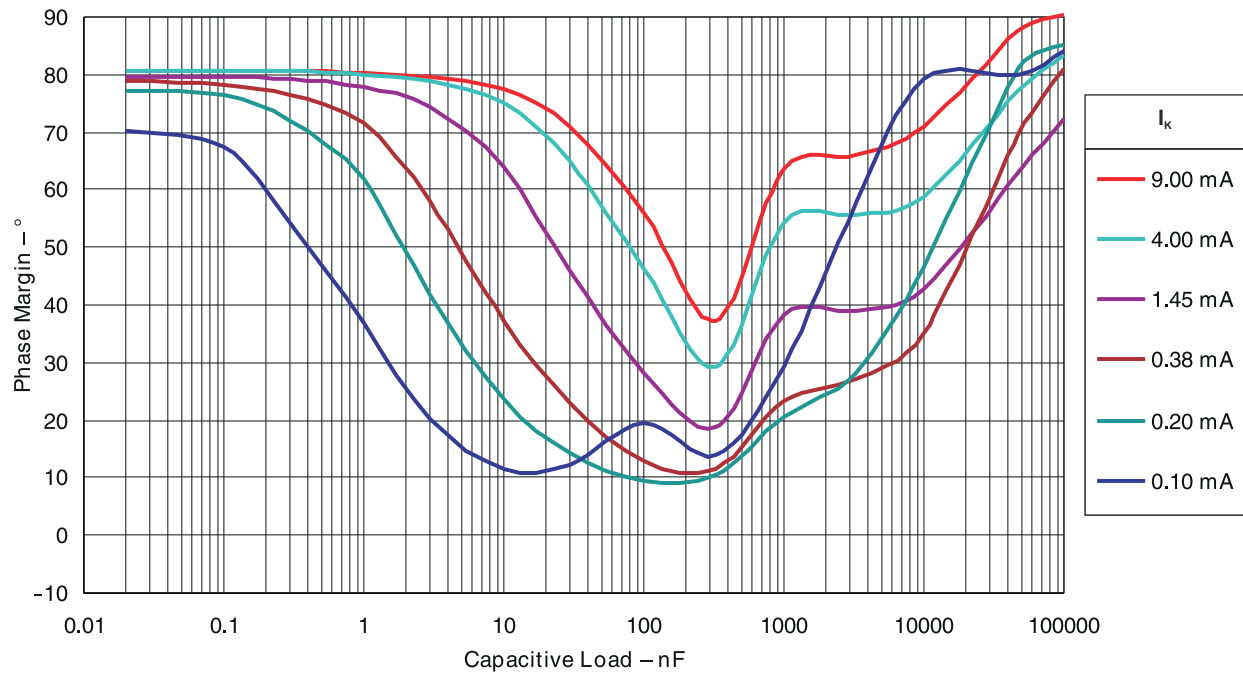

Figure 5-21. Phase Margin vs Capacitive Load $V_{KA} = 5.00V$, $T_A = 25^\circ C$ (For TLV431B-Q1)

6 Parameter Measurement Information

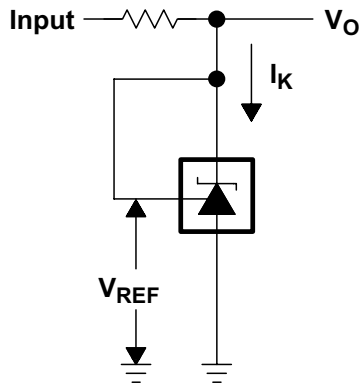

Figure 6-1. Test Circuit for $V_{KA} = V_{REF}$, $V_O = V_{KA} = V_{REF}$

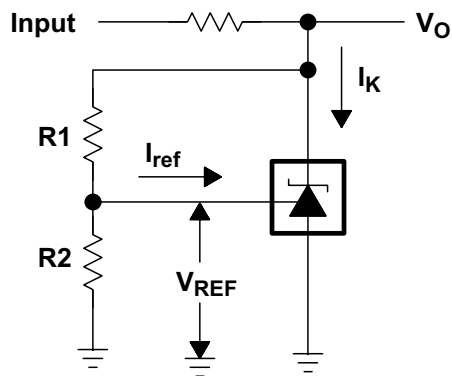

Figure 6-2. Test Circuit for $V_{KA} > V_{REF}$, $V_O = V_{KA} = V_{REF} \times (1 + R1/R2) + I_{ref} \times R1$

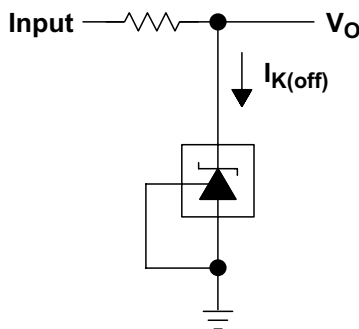

Figure 6-3. Test Circuit for $I_{K(off)}$

7 Detailed Description

7.1 Overview

TLV431 is a low power counterpart to TL431, having lower reference voltage (1.24V vs 2.5V) for lower voltage adjustability and lower minimum cathode current ($I_{k(\min)}=100\mu\text{A}$ vs 1mA). Like TL431, the TLV431 is used in conjunction with its key components to behave as a single voltage reference, error amplifier, voltage clamp or comparator with integrated reference.

TLV431 can be operated and adjusted to cathode voltages from 1.24V to 6V, making this part optimum for a wide range of end equipments in industrial, auto, telecom & computing. For this device to behave as a shunt regulator or error amplifier, $> 100\mu\text{A}$ ($I_{\min(\max)}$) must be supplied in to the cathode pin. Under this condition, feedback can be applied from the Cathode and Ref pins to create a replica of the internal reference voltage.

Various reference voltage options can be purchased with initial tolerances (at 25°C) of 0.5%, and 1%. These reference options are denoted by B (0.5%) and A (1.0%) after the TLV431x-Q1.

The TLV431x-Q1 devices are characterized for operation from -40°C to 125°C .

7.2 Functional Block Diagram

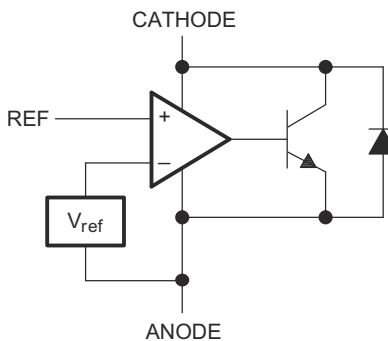

7.3 Feature Description

TLV431 consists of an internal reference and amplifier that outputs a sink current based on the difference between the reference pin and the virtual internal pin. The sink current is produced by an internal Darlington pair.

When operated with enough voltage headroom ($\geq 1.24\text{V}$) and cathode current (I_{ka}), TLV431 forces the reference pin to 1.24V. However, the reference pin can not be left floating, as it needs $I_{ref} \geq 0.5\mu\text{A}$ (please see the [Section 7.2](#)). This is because the reference pin is driven into an npn, which needs base current in order to operate properly.

When feedback is applied from the Cathode and Reference pins, TLV431 behaves as a Zener diode, regulating to a constant voltage dependent on current being supplied into the cathode. This is due to the internal amplifier and reference entering the proper operating regions. The same amount of current needed in the above feedback situation must be applied to this device in open loop, servo or error amplifying implementations for it to be in the proper linear region giving TLV431 enough gain.

Unlike many linear regulators, TLV431 is internally compensated to be stable without an output capacitor between the cathode and anode. However, if it is desired to use an output capacitor [Figure 5-18](#) can be used as a guide to assist in choosing the correct capacitor to maintain stability.

7.4 Device Functional Modes

7.4.1 Open Loop (Comparator)

When the cathode/output voltage or current of TLV431 is not being fed back to the reference/input pin in any form, this device is operating in open loop. With proper cathode current (I_{ka}) applied to this device, TLV431 will have the characteristics shown in [Figure 5-6](#). With such high gain in this configuration, TLV431 is typically used as a comparator. With the reference integrated makes TLV431 the preferred choice when users are trying to monitor a certain level of a single signal.

7.4.2 Closed Loop

When the cathode/output voltage or current of TLV431 is being fed back to the reference/input pin in any form, this device is operating in closed loop. The majority of applications involving TLV431 use it in this manner to regulate a fixed voltage or current. The feedback enables this device to behave as an error amplifier, computing a portion of the output voltage and adjusting it to maintain the desired regulation. This is done by relating the output voltage back to the reference pin in a manner to make it equal to the internal reference voltage, which can be accomplished via resistive or direct feedback.

8 Applications and Implementation

Note

Information in the following applications sections is not part of the TI component specification, and TI does not warrant its accuracy or completeness. TI's customers are responsible for determining suitability of components for their purposes, as well as validating and testing their design implementation to confirm system functionality.

8.1 Application Information

Figure 8-1 shows the TLV431A, or TLV431B used in a 3.3V isolated flyback supply. Output voltage V_O can be as low as reference voltage V_{REF} ($1.24V \pm 1\%$). The output of the regulator, plus the forward voltage drop of the optocoupler LED ($1.24 + 1.4 = 2.64V$), determine the minimum voltage that can be regulated in an isolated supply configuration. Regulated voltage as low as 2.7Vdc is possible in the topology shown in Figure 8-1.

The 431 family of devices are prevalent in these applications, being designers go to choice for secondary side regulation. Due to this prevalence, this section explains the operation and design in both states of TLV431 that this application sees, open loop (Comparator + Vref) & closed loop (Shunt Regulator).

Further information about system stability and using a TLV431 device for compensation can be found in the application note *Compensation Design With TL431 for UCC28600*, [SLUA671](#).

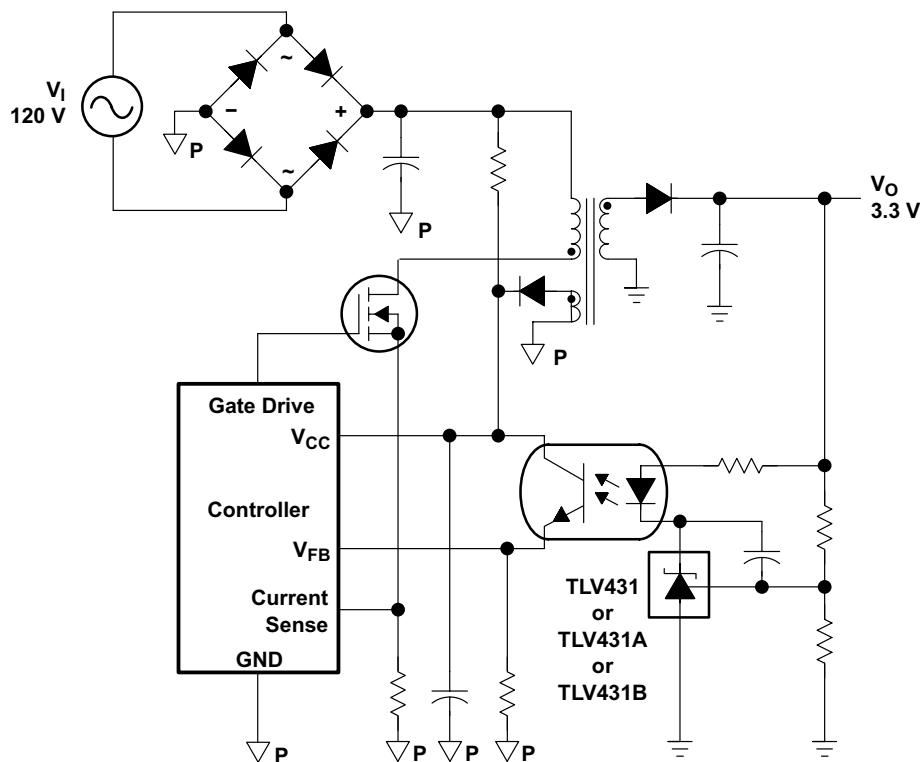

Figure 8-1. Flyback With Isolation Using TLV431, TLV431A, or TLV431B as Voltage Reference and Error Amplifier

8.2 Typical Applications

8.2.1 Comparator with Integrated Reference (Open Loop)

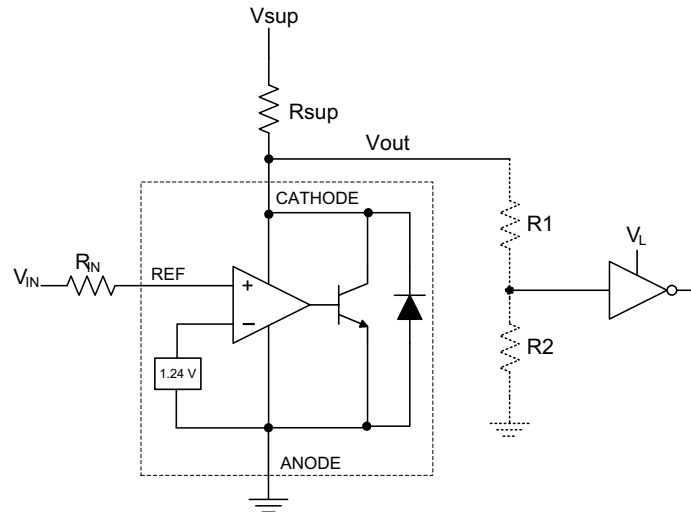

Figure 8-2. Comparator Application Schematic

8.2.1.1 Design Requirements

For this design example, use the parameters listed in [Table 8-1](#) as the input parameters.

Table 8-1. Design Parameters

DESIGN PARAMETER	EXAMPLE VALUE
Input Voltage Range	0V to 5V
Input Resistance	10k Ω
Supply Voltage	5V
Cathode Current (I_k)	500 μ A
Output Voltage Level	$\sim 1V - V_{sup}$
Logic Input Thresholds V_{IH}/V_{IL}	V_L

8.2.1.2 Detailed Design Procedure

When using TLV431 as a comparator with reference, determine the following:

- Input voltage range
- Reference voltage accuracy
- Output logic input high and low level thresholds
- Current source resistance

8.2.1.2.1 Basic Operation

In the configuration shown in [Figure 8-2](#) TLV431 behaves as a comparator, comparing the V_{ref} pin voltage to the internal virtual reference voltage. When provided a proper cathode current (I_k), TLV431 has enough open loop gain to provide a quick response. With the TLV431's min Operating Current maximum (I_{min}) being 55 μ A to 100 μ A over temperature, operation below that can result in low gain, leading to a slow response.

8.2.1.2.2 Overdrive

Slow or inaccurate responses can also occur when the reference pin is not provided enough overdrive voltage. This is the amount of voltage that is higher than the internal virtual reference. The internal virtual reference voltage is within the range of $1.24V \pm(0.5\% \text{ or } 1.0\%)$ depending on which version is being used.

The more overdrive voltage provided, the faster the TLV431 responds. This can be seen in figures [Figure 8-3](#) and [Figure 8-4](#), where the images display the output responses to various input voltages.

For applications where TLV431 is being used as a comparator, set the trip point to greater than the positive expected error (i.e. +1.0% for the A version). For fast response, set the trip point to > 10% of the internal V_{ref} .

For minimal voltage drop or difference from V_{in} to the ref pin, TI recommends using an input resistor < 10k Ω to provide I_{ref} .

8.2.1.2.3 Output Voltage and Logic Input Level

For the TLV431 to properly be used as a comparator, the logic output must be readable by the receiving logic device. This is accomplished by knowing the input high and low level threshold voltage levels, typically denoted by V_{IH} & V_{IL} .

As seen in [Figure 8-3](#), TLV431's output low level voltage in open-loop/comparator mode is ~1 V, which is sufficient for some 3.3V supplied logic. However, would not work for 2.5V and 1.8V supplied logic. In order to accommodate this a resistive divider can be tied to the output to attenuate the output voltage to a voltage legible to the receiving low voltage logic device.

TLV431's output high voltage is approximately V_{sup} due to TLV431 being open-collector. If V_{sup} is much higher than the receiving logic's maximum input voltage tolerance, the output must be attenuated to accommodate the outgoing logic's reliability.

When using a resistive divider on the output, be sure to make the sum of the resistive divider ($R1$ & $R2$ in [Figure 8-2](#)) is much greater than R_{sup} to not interfere with TLV431's ability to pull close to V_{sup} when turning off.

8.2.1.2.3.1 Input Resistance

TLV431 requires an input resistance in this application to source the reference current (I_{ref}) needed from this device to be in the proper operating regions while turning on. The actual voltage seen at the ref pin will be $V_{ref}=V_{in}-I_{ref}*R_{in}$. Since I_{ref} can be as high as 0.5 μA TI recommends using a resistance small enough that will mitigate the error that I_{ref} creates from V_{in} .

8.2.1.3 Application Curves

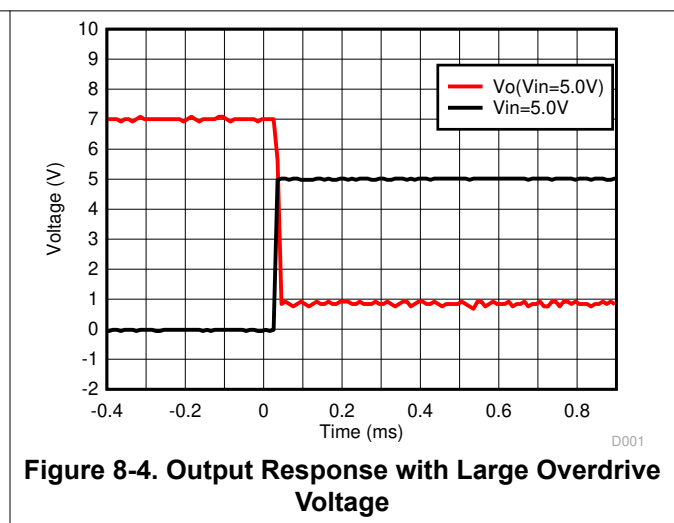
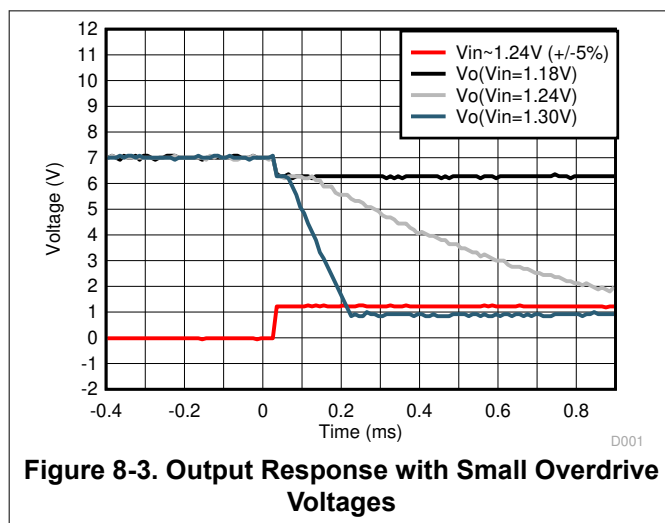

8.2.2 Shunt Regulator/Reference

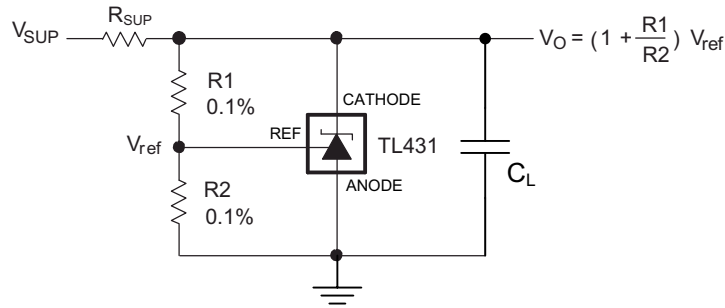

Figure 8-5. Shunt Regulator Schematic

8.2.2.1 Design Requirements

For this design example, use the parameters listed in Table 8-2 as the input parameters.

Table 8-2. Design Parameters

DESIGN PARAMETER	EXAMPLE VALUE
Reference Initial Accuracy	1.0%
Supply Voltage	6V
Cathode Current (I _k)	1mA
Output Voltage Level	1.24V - 6V
Load Capacitance	100pF
Feedback Resistor Values and Accuracy (R1 & R2)	10kΩ

8.2.2.2 Detailed Design Procedure

When using TLV431 as a Shunt Regulator, determine the following:

- Input voltage range
- Temperature range
- Total accuracy
- Cathode current
- Reference initial accuracy
- Output capacitance

8.2.2.2.1 Programming Output/Cathode Voltage

To program the cathode voltage to a regulated voltage a resistive bridge must be shunted between the cathode and anode pins with the mid point tied to the reference pin. This can be seen in Figure 8-5, with R1 & R2 being the resistive bridge. The cathode/output voltage in the shunt regulator configuration can be approximated by the equation shown in Figure 8-5. The cathode voltage can be more accurately determined by taking in to account the cathode current:

$$V_O = (1 + R1/R2) * V_{ref} - I_{ref} * R1$$

For this equation to be valid, TLV431 must be fully biased so that there is enough open loop gain to mitigate any gain error. This can be done by meeting the I_{min} spec denoted in Section 5.4 table.

8.2.2.2.2 Total Accuracy

When programming the output above unity gain ($V_{ka}=V_{ref}$), TLV431 is susceptible to other errors that can effect the overall accuracy beyond V_{ref} . These errors include:

- R1 and R2 accuracies
- $V_{I(dev)}$ - Change in reference voltage over temperature
- $\Delta V_{ref} / \Delta V_{KA}$ - Change in reference voltage to the change in cathode voltage
- $|z_{KA}|$ - Dynamic impedance, causing a change in cathode voltage with cathode current

Worst case cathode voltage can be determined taking all of the variables in to account. Application note [SLVA445](#) assists designers in setting the shunt voltage to achieve optimum accuracy for this device.

8.2.2.2.3 Stability

Though TLV431 is stable with no capacitive load, the device that receives the shunt regulator's output voltage can present a capacitive load that is within the TLV431 region of stability, shown in [Figure 5-18](#). Also, designers can use capacitive loads to improve the transient response or for power supply decoupling.

8.2.2.3 Application Curve

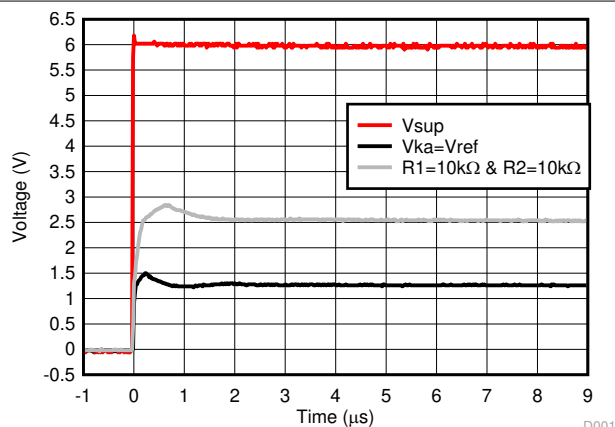

Figure 8-6. TLV431 Start-Up Response

8.3 Power Supply Recommendations

When using TLV431 as a Linear Regulator to supply a load, designers typically use a bypass capacitor on the output/cathode pin. When doing this, be sure that the capacitance is within the stability criteria shown in [Figure 5-18](#).

To not exceed the maximum cathode current, be sure that the supply voltage is current limited. Also, be sure to limit the current being driven into the Ref pin, as not to exceed it's absolute maximum rating.

For applications shunting high currents, pay attention to the cathode and anode trace lengths, adjusting the width of the traces to have the proper current density.

8.4 Layout

8.4.1 Layout Guidelines

Place decoupling capacitors as close to the device as possible. Use appropriate widths for traces when shunting high currents to avoid excessive voltage drops.

8.4.2 Layout Example

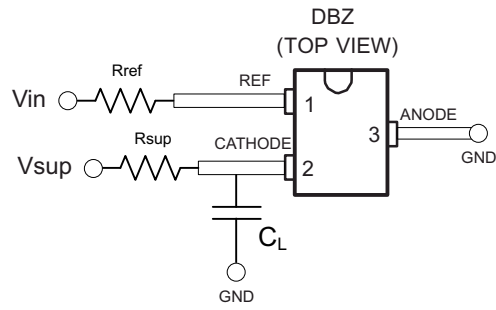

Figure 8-7. DBZ Layout Example

9 Device and Documentation Support

9.1 Receiving Notification of Documentation Updates

To receive notification of documentation updates, navigate to the device product folder on ti.com. Click on *Notifications* to register and receive a weekly digest of any product information that has changed. For change details, review the revision history included in any revised document.

9.2 Support Resources

[TI E2E™ support forums](#) are an engineer's go-to source for fast, verified answers and design help — straight from the experts. Search existing answers or ask your own question to get the quick design help you need.

Linked content is provided "AS IS" by the respective contributors. They do not constitute TI specifications and do not necessarily reflect TI's views; see TI's [Terms of Use](#).

9.3 Trademarks

TI E2E™ is a trademark of Texas Instruments.

All trademarks are the property of their respective owners.

9.4 Electrostatic Discharge Caution



This integrated circuit can be damaged by ESD. Texas Instruments recommends that all integrated circuits be handled with appropriate precautions. Failure to observe proper handling and installation procedures can cause damage.

ESD damage can range from subtle performance degradation to complete device failure. Precision integrated circuits may be more susceptible to damage because very small parametric changes could cause the device not to meet its published specifications.

9.5 Glossary

[TI Glossary](#) This glossary lists and explains terms, acronyms, and definitions.

10 Revision History

NOTE: Page numbers for previous revisions may differ from page numbers in the current version.



Changes from Revision A (October 2017) to Revision B (March 2024)	Page
• Updated the numbering format for tables, figures, and cross-references throughout the document.....	1
• Updated pinout diagrams.....	3
• Updated <i>Typical Applications Design Requirements</i>	21

Changes from Revision * (December 2008) to Revision A (October 2017)	Page
• Added Automotive AEC-Q100 feature	1
• Added New typical curves	15

11 Mechanical, Packaging, and Orderable Information

The following pages include mechanical packaging and orderable information. This information is the most current data available for the designated devices. This data is subject to change without notice and revision of this document. For browser based versions of this data sheet, refer to the left hand navigation.

PACKAGING INFORMATION

Orderable Device	Status (1)	Package Type	Package Drawing	Pins	Package Qty	Eco Plan (2)	Lead finish/ Ball material (6)	MSL Peak Temp (3)	Op Temp (°C)	Device Marking (4/5)	Samples
TLV431AQDBVRQ1	ACTIVE	SOT-23	DBV	5	3000	RoHS & Green	NIPDAU	Level-1-260C-UNLIM	-40 to 125	VONQ	
TLV431BQDBVRQ1	ACTIVE	SOT-23	DBV	5	3000	RoHS & Green	NIPDAU	Level-1-260C-UNLIM	-40 to 125	VOMQ	
TLV431BQDBZRQ1	ACTIVE	SOT-23	DBZ	3	3000	RoHS & Green	NIPDAU	Level-1-260C-UNLIM	-40 to 125	VOQQ	

(1) The marketing status values are defined as follows:

ACTIVE: Product device recommended for new designs.

LIFEBUY: TI has announced that the device will be discontinued, and a lifetime-buy period is in effect.

NRND: Not recommended for new designs. Device is in production to support existing customers, but TI does not recommend using this part in a new design.

PREVIEW: Device has been announced but is not in production. Samples may or may not be available.

OBSELETE: TI has discontinued the production of the device.

(2) **RoHS:** TI defines "RoHS" to mean semiconductor products that are compliant with the current EU RoHS requirements for all 10 RoHS substances, including the requirement that RoHS substance do not exceed 0.1% by weight in homogeneous materials. Where designed to be soldered at high temperatures, "RoHS" products are suitable for use in specified lead-free processes. TI may reference these types of products as "Pb-Free".

RoHS Exempt: TI defines "RoHS Exempt" to mean products that contain lead but are compliant with EU RoHS pursuant to a specific EU RoHS exemption.

Green: TI defines "Green" to mean the content of Chlorine (Cl) and Bromine (Br) based flame retardants meet JS709B low halogen requirements of <=1000ppm threshold. Antimony trioxide based flame retardants must also meet the <=1000ppm threshold requirement.

(3) MSL, Peak Temp. - The Moisture Sensitivity Level rating according to the JEDEC industry standard classifications, and peak solder temperature.

(4) There may be additional marking, which relates to the logo, the lot trace code information, or the environmental category on the device.

(5) Multiple Device Markings will be inside parentheses. Only one Device Marking contained in parentheses and separated by a "~" will appear on a device. If a line is indented then it is a continuation of the previous line and the two combined represent the entire Device Marking for that device.

(6) Lead finish/Ball material - Orderable Devices may have multiple material finish options. Finish options are separated by a vertical ruled line. Lead finish/Ball material values may wrap to two lines if the finish value exceeds the maximum column width.

Important Information and Disclaimer:The information provided on this page represents TI's knowledge and belief as of the date that it is provided. TI bases its knowledge and belief on information provided by third parties, and makes no representation or warranty as to the accuracy of such information. Efforts are underway to better integrate information from third parties. TI has taken and continues to take reasonable steps to provide representative and accurate information but may not have conducted destructive testing or chemical analysis on incoming materials and chemicals. TI and TI suppliers consider certain information to be proprietary, and thus CAS numbers and other limited information may not be available for release.

In no event shall TI's liability arising out of such information exceed the total purchase price of the TI part(s) at issue in this document sold by TI to Customer on an annual basis.

OTHER QUALIFIED VERSIONS OF TLV431A-Q1, TLV431B-Q1 :

- Catalog : [TLV431A](#), [TLV431B](#)

NOTE: Qualified Version Definitions:

- Catalog - TI's standard catalog product

TAPE AND REEL INFORMATION

QUADRANT ASSIGNMENTS FOR PIN 1 ORIENTATION IN TAPE

*All dimensions are nominal

Device	Package Type	Package Drawing	Pins	SPQ	Reel Diameter (mm)	Reel Width W1 (mm)	A0 (mm)	B0 (mm)	K0 (mm)	P1 (mm)	W (mm)	Pin1 Quadrant
TLV431AQDBVRQ1	SOT-23	DBV	5	3000	179.0	8.4	3.2	3.2	1.4	4.0	8.0	Q3
TLV431BQDBVRQ1	SOT-23	DBV	5	3000	180.0	8.4	3.2	3.2	1.4	4.0	8.0	Q3
TLV431BQDBZRQ1	SOT-23	DBZ	3	3000	180.0	8.4	3.15	2.95	1.22	4.0	8.0	Q3

TAPE AND REEL BOX DIMENSIONS

*All dimensions are nominal

Device	Package Type	Package Drawing	Pins	SPQ	Length (mm)	Width (mm)	Height (mm)
TLV431AQDBVRQ1	SOT-23	DBV	5	3000	200.0	183.0	25.0
TLV431BQDBVRQ1	SOT-23	DBV	5	3000	200.0	183.0	25.0
TLV431BQDBZRQ1	SOT-23	DBZ	3	3000	200.0	183.0	25.0

EXAMPLE BOARD LAYOUT

DBV0005A

SOT-23 - 1.45 mm max height

SMALL OUTLINE TRANSISTOR



LAND PATTERN EXAMPLE
EXPOSED METAL SHOWN
SCALE:15X



SOLDER MASK DETAILS

4214839/J 02/2024

NOTES: (continued)

- 6. Publication IPC-7351 may have alternate designs.
- 7. Solder mask tolerances between and around signal pads can vary based on board fabrication site.

EXAMPLE STENCIL DESIGN

DBV0005A

SOT-23 - 1.45 mm max height

SMALL OUTLINE TRANSISTOR



SOLDER PASTE EXAMPLE
BASED ON 0.125 mm THICK STENCIL
SCALE:15X

4214839/J 02/2024

NOTES: (continued)

8. Laser cutting apertures with trapezoidal walls and rounded corners may offer better paste release. IPC-7525 may have alternate design recommendations.
9. Board assembly site may have different recommendations for stencil design.

DBZ0003A



PACKAGE OUTLINE

SOT-23 - 1.12 mm max height

SMALL OUTLINE TRANSISTOR

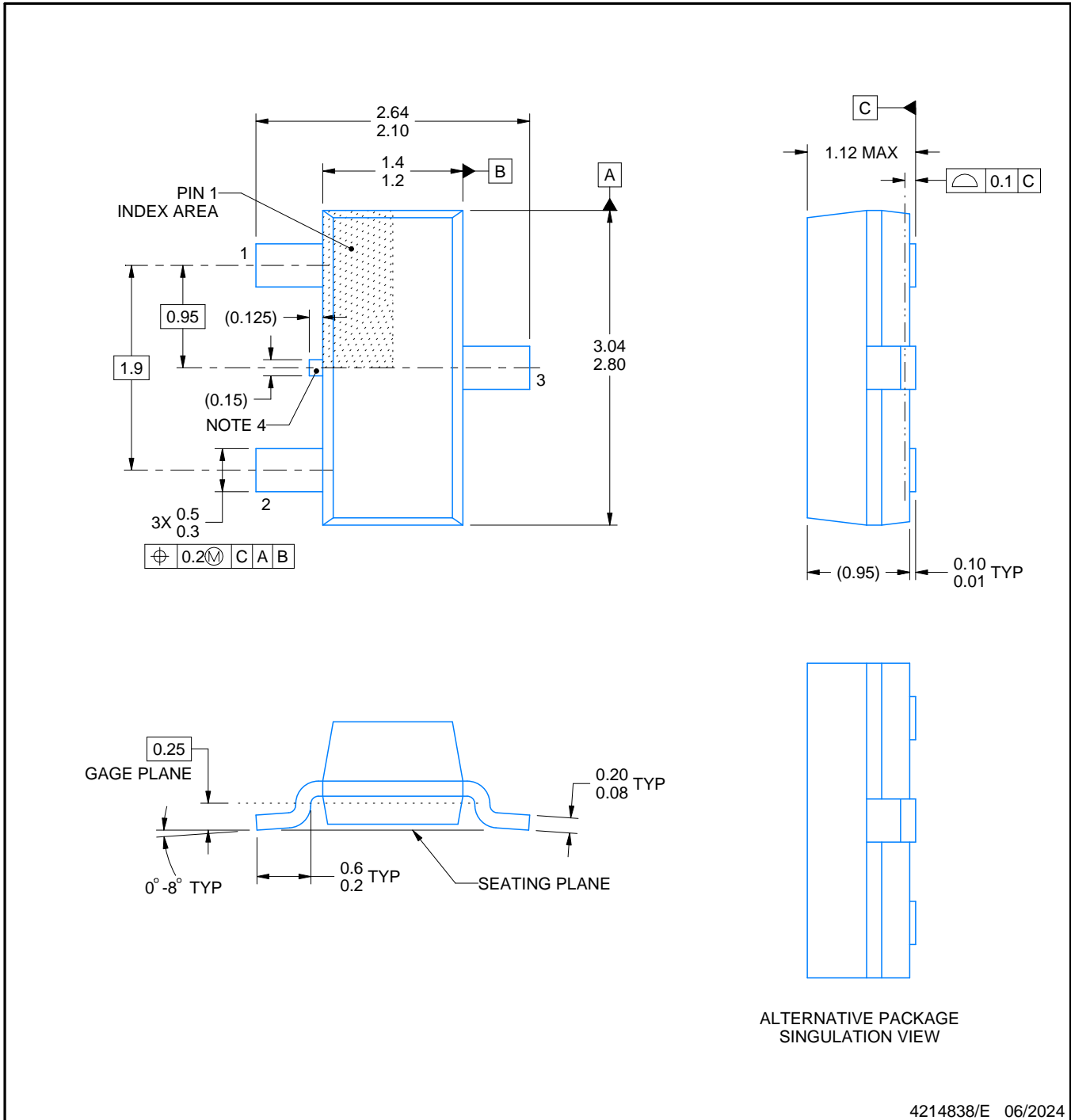

4214838/E 06/2024

NOTES:

1. All linear dimensions are in millimeters. Any dimensions in parenthesis are for reference only. Dimensioning and tolerancing per ASME Y14.5M.
2. This drawing is subject to change without notice.
3. Reference JEDEC registration TO-236, except minimum foot length.
4. Support pin may differ or may not be present.
5. Body dimensions do not include mold flash, protrusions, or gate burrs. Mold flash, protrusions, or gate burrs shall not exceed 0.25mm per side

EXAMPLE BOARD LAYOUT

DBZ0003A

SOT-23 - 1.12 mm max height

SMALL OUTLINE TRANSISTOR

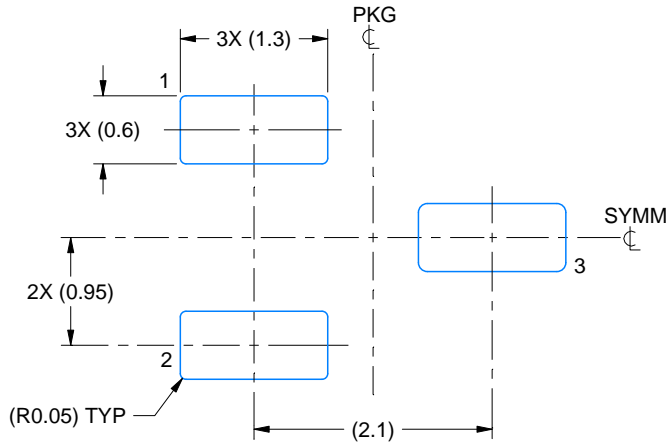

LAND PATTERN EXAMPLE
SCALE:15X

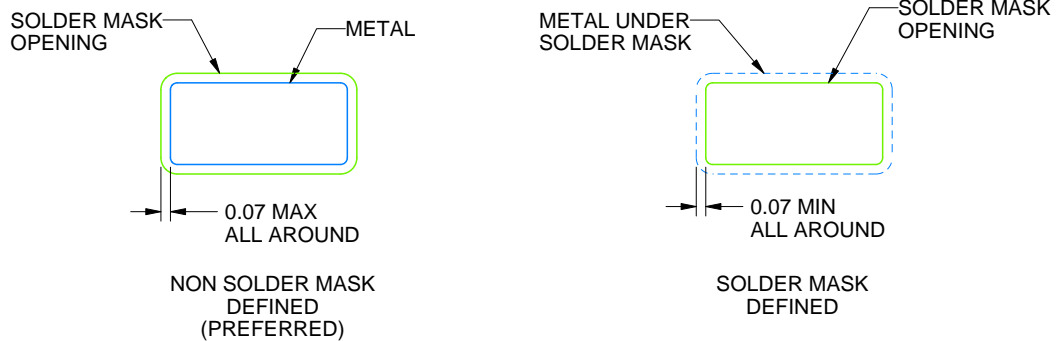

SOLDER MASK DETAILS

4214838/E 06/2024

NOTES: (continued)

5. Publication IPC-7351 may have alternate designs.
6. Solder mask tolerances between and around signal pads can vary based on board fabrication site.

EXAMPLE STENCIL DESIGN

DBZ0003A

SOT-23 - 1.12 mm max height

SMALL OUTLINE TRANSISTOR

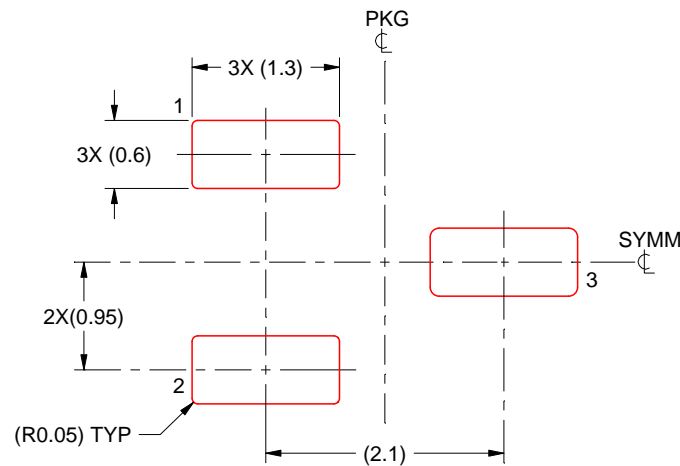

SOLDER PASTE EXAMPLE
BASED ON 0.125 THICK STENCIL
SCALE:15X

4214838/E 06/2024

NOTES: (continued)

7. Laser cutting apertures with trapezoidal walls and rounded corners may offer better paste release. IPC-7525 may have alternate design recommendations.
8. Board assembly site may have different recommendations for stencil design.

IMPORTANT NOTICE AND DISCLAIMER

TI PROVIDES TECHNICAL AND RELIABILITY DATA (INCLUDING DATA SHEETS), DESIGN RESOURCES (INCLUDING REFERENCE DESIGNS), APPLICATION OR OTHER DESIGN ADVICE, WEB TOOLS, SAFETY INFORMATION, AND OTHER RESOURCES "AS IS" AND WITH ALL FAULTS, AND DISCLAIMS ALL WARRANTIES, EXPRESS AND IMPLIED, INCLUDING WITHOUT LIMITATION ANY IMPLIED WARRANTIES OF MERCHANTABILITY, FITNESS FOR A PARTICULAR PURPOSE OR NON-INFRINGEMENT OF THIRD PARTY INTELLECTUAL PROPERTY RIGHTS.

These resources are intended for skilled developers designing with TI products. You are solely responsible for (1) selecting the appropriate TI products for your application, (2) designing, validating and testing your application, and (3) ensuring your application meets applicable standards, and any other safety, security, regulatory or other requirements.

These resources are subject to change without notice. TI grants you permission to use these resources only for development of an application that uses the TI products described in the resource. Other reproduction and display of these resources is prohibited. No license is granted to any other TI intellectual property right or to any third party intellectual property right. TI disclaims responsibility for, and you will fully indemnify TI and its representatives against, any claims, damages, costs, losses, and liabilities arising out of your use of these resources.

TI's products are provided subject to [TI's Terms of Sale](#) or other applicable terms available either on [ti.com](https://www.ti.com) or provided in conjunction with such TI products. TI's provision of these resources does not expand or otherwise alter TI's applicable warranties or warranty disclaimers for TI products.

TI objects to and rejects any additional or different terms you may have proposed.

Mailing Address: Texas Instruments, Post Office Box 655303, Dallas, Texas 75265
Copyright © 2024, Texas Instruments Incorporated