

# TPS23730 IEEE 802.3bt Type 3 PoE PD with High Efficiency DC-DC Controller

## 1 Features

- Complete IEEE 802.3bt Type 3 (Class 1-6) PoE PD Solution
  - EA Gen 2 logo-ready (PoE 2 PD Controller)
  - Robust 100-V, 0.3-Ω (typ) Hotswap MOSFET
  - Supports power levels for up to 60-W operation
  - Allocated power indicator outputs - parallel or serial encoding selectable
- Integrated PWM controller for flyback or Active Clamp Forward configuration
  - Flyback control with primary-side regulation
    - Supports CCM operation
    - ±1.5% (typ, 5-V output) load regulation (0-100% load range) — with Sync FET
  - Also supports secondary-side regulation
  - Soft-start control with advanced startup and hiccup mode overload protection
  - Soft-stop shutdown
  - Adjustable frequency with synchronization
  - Programmable frequency dithering for EMI
- Automatic Maintain Power Signature (MPS)
  - Auto-adjust to PSE type and load current with auto-stretch
- Primary adapter priority input
- –40°C to 125°C junction temperature range

## 2 Applications

- Video and VoIP Telephones
- Access Points
- Pass-through System
- Security Cameras
- Redundant Power Feeds or Power Sharing

## 3 Description

The TPS23730 device combines a Power over Ethernet (PoE) powered device (PD) interface, and a current-mode DC-DC controller optimized for flyback and active clamp forward (ACF) switching regulator designs. In the case of flyback configuration, the use of primary-side regulation (PSR) is supported. The PoE interface supports the IEEE 802.3bt standard for applications needing up to 51 W or less at PD input.

Programmable spread spectrum frequency dithering (SSFD) is provided to minimize the size and cost of EMI filter. Advanced Startup with adjustable soft-start helps to use minimal bias capacitor while simplifying converter startup and hiccup design, also ensuring that IEEE 802.3bt startup requirements are met.

The soft-stop feature minimizes stress on switching power FETs, allowing FET BOM cost reduction.

The PSR feature of the DC-DC controller uses feedback from an auxiliary winding for control of the output voltage, eliminating the need for external shunt regulator and optocoupler. It is optimized for continuous conduction mode (CCM), and can work with secondary side synchronous rectification, resulting in optimum efficiency, regulation accuracy and step load response over multiple outputs.

The DC-DC controller features slope compensation and blanking. Typical switching frequency is 250 kHz.

The automatic MPS enables applications with low power modes or multiple power feeds. It automatically adjusts its pulsed current amplitude and duration according to PSE Type and system conditions, to maintain power while minimizing consumption.

### Device Information<sup>(1)</sup>

PART NUMBER	PACKAGE	BODY SIZE (NOM)
TPS23730	VQFN (45)	7.00 mm × 5.00 mm

(1) For all available packages, see the orderable addendum at the end of the data sheet.

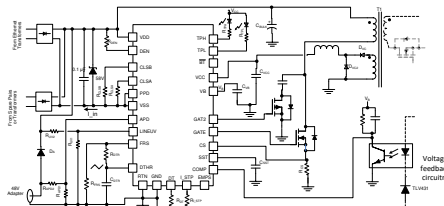

**Simplified Application**



## Table of Contents

<b>1 Features</b> .....	1	8.4 Device Functional Modes.....	29
<b>2 Applications</b> .....	1	<b>9 Application and Implementation</b> .....	44
<b>3 Description</b> .....	1	9.1 Application Information.....	44
<b>4 Revision History</b> .....	2	9.2 Typical Application.....	44
<b>5 Device Comparison Table</b> .....	3	<b>10 Power Supply Recommendations</b> .....	49
<b>6 Pin Configuration and Functions</b> .....	3	<b>11 Layout</b> .....	50
<b>7 Specifications</b> .....	6	11.1 Layout Guidelines.....	50
7.1 Absolute Maximum Ratings .....	6	11.2 Layout Example.....	50
7.2 ESD Ratings .....	6	11.3 EMI Containment.....	50
7.3 Recommended Operating Conditions .....	7	11.4 Thermal Considerations and OTSD.....	50
7.4 Thermal Information .....	7	11.5 ESD.....	50
7.5 Electrical Characteristics: DC-DC Controller Section .....	8	<b>12 Device and Documentation Support</b> .....	51
7.6 Electrical Characteristics PoE .....	11	12.1 Documentation Support.....	51
7.7 Typical Characteristics.....	14	12.2 Support Resources.....	51
<b>8 Detailed Description</b> .....	18	12.3 Trademarks.....	51
8.1 Overview.....	18	12.4 Electrostatic Discharge Caution.....	51
8.2 Functional Block Diagram.....	19	12.5 Glossary.....	51
8.3 Feature Description.....	20	<b>13 Mechanical, Packaging, and Orderable Information</b> .....	51

## 4 Revision History

NOTE: Page numbers for previous revisions may differ from page numbers in the current version.

<b>Changes from Revision A (September 2020) to Revision B (November 2020)</b>	<b>Page</b>
• Updated package type in <i>Device Information</i> table.....	1
• Updated package type in pinout drawing caption.....	3
• Updated package type in <i>Thermal Information</i> table.....	6

<b>Changes from Revision * (May 2020) to Revision A (September 2020)</b>	<b>Page</b>
• Updated the numbering format for tables, figures and cross-references throughout the document.....	1
• Changed status from "Advance Information" to "Production Data".....	1

### 5 Device Comparison Table

KEY FEATURES	TPS23730	TPS23731	TPS23734
Class Range	1-6	1-4	1-4
ACF Support	Yes	No	Yes
SSFD	Yes	Yes	Yes
Soft-stop	Yes	Yes	Yes
Advanced Startup	Yes	Yes	Yes
PSR (Flyback)	Yes	Yes	Yes
Auto MPS	Yes	Yes	Yes
PPD	Yes	No	No
APD	Yes	Yes	Yes
PoE allocated power and AUX power indicator(s)	TPH/TPL (parallel) or TPL (serial)	T2P, APDO	T2P, APDO

### 6 Pin Configuration and Functions

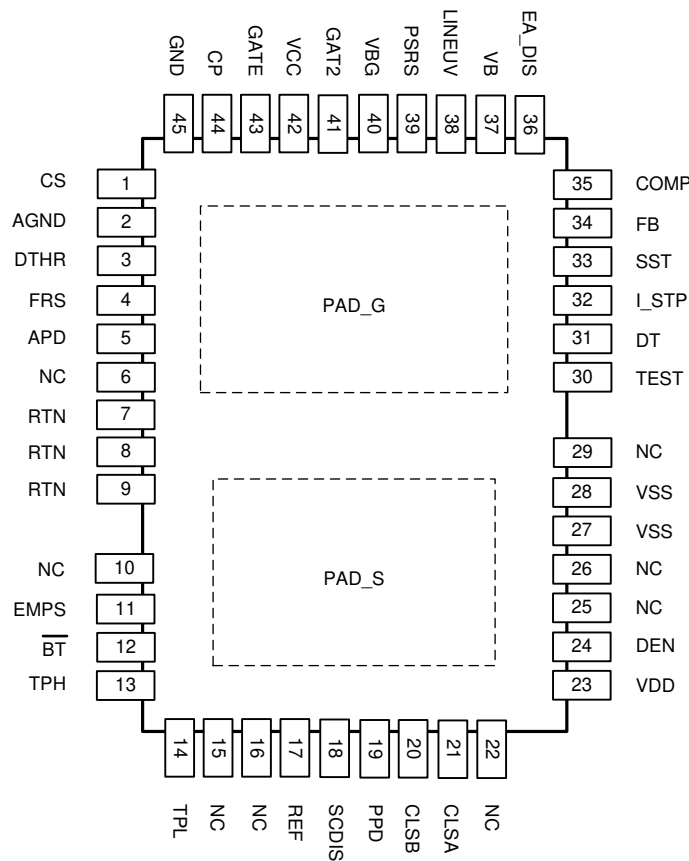

Figure 6-1. RMT Package 45-Pin VQFN Top View

**Table 6-1. Pin Functions**

PIN		I/O	DESCRIPTION
NO.	NAME		
1	CS	I/O	DC-DC controller current sense input. Connect directly to the external power current sense resistor.
2	AGND	-	AGND is the DC-DC converter analog return. Tie to RTN and GND on the circuit board.
3	DTHR	O	Used for spread spectrum frequency dithering. Connect a capacitor (determines the modulating frequency) from DTHR to RTN and a resistor (determines the amount of dithering) from DTHR to FRS. If dithering is not used, short DTHR to VB pin.
4	FRS	I	This pin controls the switching frequency of the DC-DC converter. Tie a resistor from this pin to RTN to set the frequency.
5	APD	I	Primary auxiliary power detect input. Raise 1.5 V above RTN to disable pass MOSFET, also turning class off. If not used, connect APD to RTN.
7, 8, 9	RTN	-	RTN is the output of the PoE hotswap and the reference ground for the DC-DC controller.
11	EMPS	I	Automatic MPS enable input, referenced to RTN, internally pulled-up to 5-V internal rail. Tie to RTN to disable automatic MPS.
12	BT	O	Indicates that a PSE applying an IEEE802.3bt (Type 3 or 4) mutual identification scheme has been identified. Open-drain, active-low output referenced to RTN. $\overline{BT}$ state remains unchanged if an auxiliary power adapter is detected via APD or PPD input. $\overline{BT}$ is also disabled if SCDIS is low.
13	TPH	O	TPH/TPL binary code indicates the PSE allocated power output. Open-drain, active-low outputs referenced to RTN. The default operation is with parallel binary code. Also, whenever an auxiliary power adapter is detected via the APD input or PPD input, both TPH and TPL pull low. Serial code over TPL can also be enabled by tying SCDIS pin to VSS. In this case, TPH becomes high impedance.
14	TPL	O	
17	REF	O	Internal 1.25-V voltage reference. Connect a 49.9-k $\Omega$ _1% resistor from REF to VSS.
18	SCDIS	I	TPL serial code disable, referenced to VSS. Leave open to select parallel TPH/TPL configuration. Tie to VSS to select serial code.
19	PPD	I	Raising $V_{PPD-VSS}$ above 2.5 V enables the hotswap MOSFET, activates TPH and TPL and turn class off. Tie PPD to VSS or float when not used.
20	CLSB	O	Connect a resistor from CLSB to VSS to program the second classification current.
21	CLSA	O	Connect a resistor from CLSA to VSS to program the first classification current.
23	VDD	—	Positive input power rail for PoE interface circuit and source of DC-DC converter start-up current. Bypass with a 0.1 $\mu$ F to VSS and protect with a TVS.
24	DEN	I/O	Connect a 25.5-k $\Omega$ resistor from DEN to VDD to provide the PoE detection signature. Pulling this pin to VSS during powered operation causes the internal hotswap MOSFET to turn off.
27, 28	VSS	-	Negative power rail derived from the PoE source.
30	TEST	O	Used internally for test purposes only. Leave open.
31	DT	I	Connect a resistor from DT to AGND to set the GATE to GAT2 dead time. Tie DT to VB to disable GAT2 operation.
32	I_STP	I	This pin sets the SST discharge current during a soft-stop event independently from the setting used during a regular soft-start event. Connect a resistor from this pin to AGND to set the DC/DC soft-stop rate.
33	SST	I/O	A capacitor from SST to RTN pin sets the soft-start ( $I_{SSC}$ charge current) and the hiccup timer ( $I_{SSD}$ discharge current) for the DC-DC converter. Connect a capacitor from this pin to RTN to set the DC/DC startup rate.
34	FB	I	Converter error amplifier inverting (feedback) input. If flyback configuration with primary-side regulation, it is typically driven by a voltage divider and capacitor from the auxiliary winding, working with CP pin, FB also being connected to the COMP compensation network. If optocoupler feedback is enabled, tie FB to VB.
35	COMP	I/O	Compensation output of the DC-DC convertor error amplifier or control loop input to the PWM. If the internal error amplifier is used, connect the compensation networks from this pin to the FB pin to compensate the converter. If optocoupler feedback is enabled, the optocoupler and its network pulled up to VB directly drives the COMP pin.
36	EA_DIS	I	Error Amplifier disable input, referenced to AGND, internally pulled-up to 5V internal rail. Leave EA_DIS open to disable the Error amplifier, to enable optocoupler feedback for example. Connect to AGND otherwise.

**Table 6-1. Pin Functions (continued)**

PIN		I/O	DESCRIPTION
NO.	NAME		
37	VB	O	5-V bias rail for DC/DC control circuits and the feedback optocoupler (when in use). Connect a 0.1- $\mu$ F capacitor from this pin to AGND to provide bypassing.
38	LINEUV	I	LINEUV is used to monitor the bulk capacitor voltage to trigger a soft-stop event when an undervoltage condition is detected if APD is low. If not used, connect LINEUV to VB pin.
39	PSRS	I	PSR Sync enable input, referenced to AGND, internally pulled-up to 5V internal rail. PSRS works with CP pin to support flyback architecture using primary-side regulation. Leave PSRS open if the flyback output stage is configured with synchronous rectification and uses PSR. If diode rectification is used, or for applications not using PSR, connect PSRS to AGND.
40	VBG	O	5-V bias rail for the switching FET gate driver circuit. For internal use only. Bypass with a 0.1- $\mu$ F ceramic capacitor to GND pin.
41	GAT2	O	Gate drive output for a second DC-DC converter switching MOSFET.
42	VCC	I/O	DC/DC converter bias voltage. The internal startup current source and converter bias winding output power this pin. Connect a 1 $\mu$ F minimum ceramic capacitor to RTN.
43	GATE	O	Gate drive output for the main DC-DC converter switching MOSFET
44	CP	O	CP provides the clamp for the primary-side regulation loop. Connect this pin to the lower end of the bias winding of the flyback transformer.
45	GND	-	.Power ground used by the flyback power FET gate driver and CP. Connect to RTN.
6, 10, 15, 16, 22, 25, 26, 29	NC	-	No connect pin. Leave open.
47	PAD_S	-	The exposed thermal pad must be connected to VSS. A large fill area is required to assist in heat dissipation.
46	PAD_G	-	The exposed thermal pad must be connected to RTN. A large fill area is required to assist in heat dissipation.

## 7 Specifications

### 7.1 Absolute Maximum Ratings

Voltage are with respect to  $V_{SS}$  (unless otherwise noted)<sup>(1)</sup>

		MIN	MAX	UNIT
Input voltage	VDD, DEN, GND, AGND, RTN <sup>(2)</sup>	-0.3	100	V
	VDD to RTN	-0.3	100	
	APD, FB, CS, EA_DIS, LINEUV, PSRS, EMPS, all to RTN	-0.3	6.5	
Input voltage	PPD, SCDIS <sup>(3)</sup>	-0.3	6.5	V
Voltage	FRS <sup>(3)</sup> , COMP, VB <sup>(3)</sup> , VBG <sup>(3)</sup> , I_STP <sup>(3)</sup> , DTHR <sup>(3)</sup> , SST <sup>(3)</sup> , DT <sup>(3)</sup> , $\overline{BT}$ , all to RTN	-0.3	6.5	V
	VCC to RTN	-0.3	19	
	GATE <sup>(3)</sup> , GAT2 <sup>(3)</sup> , all to RTN	-0.3	VCC+0.3	
	CP to GND	-0.3	60	
	GND, AGND, all to RTN	-0.3	0.3	
	REF <sup>(3)</sup> , CLSA <sup>(3)</sup> , CLSB <sup>(3)</sup>	-0.3	6.5	
	TPH, TPL, all to RTN	-0.3	19	
Sourcing current	VB, VBG, VCC	Internally limited		mA
	COMP	Internally limited		
	REF	Internally limited		
Sourcing current	CLSA, CLSB		65	mA
Sinking current	RTN	Internally limited		mA
	DEN		1	
	COMP	Internally limited		
Sinking current	TPH, TPL, $\overline{BT}$		10	mA
Peak sourcing current	CP		2	A
Peak sinking current	CP		0.7	A
$T_{J(max)}$	Maximum junction temperature	Internally Limited		°C
$T_{stg}$	Storage temperature	-65	150	°C

- (1) Stresses beyond those listed under *Absolute Maximum Ratings* may cause permanent damage to the device. These are stress ratings only, which do not imply functional operation of the device at these or any other conditions beyond those indicated under *Recommended Operating Conditions*. Exposure to absolute-maximum-rated conditions for extended periods may affect device reliability.
- (2)  $I_{RTN} = 0$  for  $V_{RTN} > 80$  V.
- (3) Do not apply voltage to these pins.

### 7.2 ESD Ratings

		VALUE	UNIT
$V_{(ESD)}$	Electrostatic discharge	Human-body model (HBM), per ANSI/ESDA/JEDEC JS-001 <sup>(1)</sup>	±2000
		Charged-device model (CDM), per JEDEC specification JESD22-C101 <sup>(2)</sup>	±500
		IEC 61000-4-2 contact discharge <sup>(3)</sup>	±8000
		IEC 61000-4-2 air-gap discharge <sup>(3)</sup>	±15000

- (1) JEDEC document JEP155 states that 500-V HBM allows safe manufacturing with a standard ESD control process.
- (2) JEDEC document JEP157 states that 250-V CDM allows safe manufacturing with a standard ESD control process.
- (3) Surges per EN61000-4-2, 1999 applied between RJ-45 and output ground and between adapter input and output ground of the TPS23730, TPS23730EVM-093 evaluation module (documentation available on the web). These were the test levels, not the failure threshold.

### 7.3 Recommended Operating Conditions

Voltage with respect to  $V_{SS}$  (unless otherwise noted)

		MIN	NOM	MAX	UNIT
Input voltage range	VDD, RTN, GND, AGND	0		60	V
	VCC to RTN	0		16	
	APD, EA_DIS, LINEUV, PSRS, FB, all to RTN	0		VB	
	CS to RTN	0		2	
	CP to GND	0		45	
Input voltage range	PPD	0		5	V
Voltage range	COMP, $\overline{BT}$ , all to RTN			VB	V
Voltage range	TPH, TPL, all to RTN	0		VCC	V
Sinking current	RTN			1.2	A
Sinking current	TPH, TPL, $\overline{BT}$			3	mA
Sourcing current	VCC			20	mA
	VB			5	
Capacitance	VB, VBG <sup>(1)</sup>	0.08	0.1	1	$\mu$ F
	VCC	0.7	1	100	
Resistance	I_STOP	16.5		499	K $\Omega$
Resistance	CLSA, CLSB <sup>(1)</sup>	30			$\Omega$
	REF <sup>(1)</sup>	48.9	49.9	50.9	k $\Omega$
	Synchronization pulse width input (when used)	35			ns
$T_J$	Operating junction temperature	-40		125	$^{\circ}$ C

(1) Voltage should not be externally applied to this pin.

### 7.4 Thermal Information

THERMAL METRIC		TPS23730	UNIT
		RMT (VQFN)	
		45 PINS	
$R_{\theta JA}$ <sup>(1)</sup>	Junction-to-ambient thermal resistance	38.5	$^{\circ}$ C/W
$R_{\theta JC(top)}$	Junction-to-case (top) thermal resistance	23.6	
$R_{\theta JB}$ <sup>(1)</sup>	Junction-to-board thermal resistance	19.3	
$\psi_{JT}$ <sup>(1)</sup>	Junction-to-top characterization parameter	6.8	
$\psi_{JB}$ <sup>(1)</sup>	Junction-to-board characterization parameter	19.3	
$R_{\theta JC(bot\_POE)}$	Junction-to-case (bottom PAD_S pad) thermal resistance	3.9	
$R_{\theta JC(bot\_DCDC)}$	Junction-to-case (bottom PAD_G pad) thermal resistance	9.1	

(1) Thermal metrics are not JEDEC standard values and are based on the TPS23731EVM-095 evaluation board.

## 7.5 Electrical Characteristics: DC-DC Controller Section

Unless otherwise noted,  $V_{DD} = 48\text{ V}$ ;  $R_{DEN} = 25.5\text{ k}\Omega$ ;  $R_{FRS} = 60.4\text{ k}\Omega$ ;  $R_{I\_STP} = 499\text{ k}\Omega$ ; CLSA, CLSB, TPH, TPL,  $\overline{BT}$ , SCDIS and PSRS open; CS, EA\_DIS, APD, EMPS, AGND and GND connected to RTN; FB, LINEUV, DT and DTHR connected to VB; PPD connected to VSS;  $C_{VB} = C_{VBG} = 0.1\text{ }\mu\text{F}$ ;  $C_{VCC} = 1\text{ }\mu\text{F}$ ;  $C_{SST} = 0.047\text{ }\mu\text{F}$ ;  $R_{REF} = 49.9\text{ k}\Omega$ ;  $8.5\text{ V} \leq V_{VCC} \leq 16\text{ V}$ ;  $-40^\circ\text{C} \leq T_J \leq 125^\circ\text{C}$ . Positive currents are into pins unless otherwise noted. Typical values are at  $25^\circ\text{C}$ . [ $V_{VSS} = V_{RTN}$ ], all voltages referred to  $V_{RTN}$ ,  $V_{AGND}$  and  $V_{GND}$  unless otherwise noted.

PARAMETER	TEST CONDITIONS	MIN	TYP	MAX	UNIT		
<b>DC-DC SUPPLY (VCC)</b>							
$V_{CUVLO\_R}$	Undervoltage lockout	$V_{VCC}$ rising	8	8.25	8.5	V	
$V_{CUVLO\_F}$		$V_{VCC}$ falling, $V_{FB} = V_{RTN}$	5.85	6.1	6.35	V	
$V_{CUVLO\_H}$		Hysteresis <sup>(1)</sup>	2	2.15	2.3	V	
$I_{RUN}$	Operating current	$V_{VCC} = 10\text{ V}$ , $V_{FB} = V_{RTN}$ , $R_{DT} = 24.9\text{ k}\Omega$ , CP with 2-k $\Omega$ pull up to 30 V		1.2	2	2.4	mA
$I_{VC\_ST}$	Startup source current	$V_{APD} = 2.5\text{ V}$					
		$V_{DD} \geq 28\text{ V}$ , $V_{VCC} = 11.7\text{ V}$	21.5	30	34	mA	
		$V_{DD} = 10.2\text{ V}$ , $V_{VCC} = 8.6\text{ V}$	1	6	17.5		
		$V_{DD} = 10.2\text{ V}$ , $V_{VCC} = 6.8\text{ V}$	8	16	32		
$t_{ST}$	Startup time, $C_{VCC} = 1\text{ }\mu\text{F}$	$V_{DD} = 10.2\text{ V}$ , $V_{VCC}(0) = 0\text{ V}$ , measure time until $V_{CUVLO\_R}$	0.25	0.7	1.15		ms
		$V_{DD} = 35\text{ V}$ , $V_{VCC}(0) = 0\text{ V}$ , measure time until $V_{CUVLO\_R}$	0.24	0.35	0.48	ms	
$V_{VC\_ST}$	VCC startup voltage	Measure $V_{VCC}$ during startup, $I_{VCC} = 0\text{ mA}$	11	12.5	14	V	
		Measure $V_{VCC}$ during startup, $I_{VCC} = 21.5\text{ mA}$	11	12.5	14		
$V_{VC\_SSTP}$	VCC soft-stop voltage	$V_{LINEUV} < V_{LIUVF}$ , Measure $V_{VCC}$ during soft-stop, $I_{VCC} = 0\text{ mA}$	11	12.5	14	V	
		$V_{LINEUV} < V_{LIUVF}$ , Measure $V_{VCC}$ during soft-stop, $I_{VCC} = 21.5\text{ mA}$	11	12.5	14		
<b><math>V_B</math></b>							
	Voltage	$V_{FB} = V_{RTN}$ , $8.5\text{ V} \leq V_{VCC} \leq 16\text{ V}$ , $0 \leq I_{VB} \leq 5\text{ mA}$		4.75	5.0	5.25	V
<b>DC-DC TIMING (FRS)</b>							
$f_{SW}$	Switching frequency	$V_{FB} = V_{RTN}$ , Measure at GATE		223	248	273	kHz
$D_{MAX}$	Duty cycle	$V_{FB} = V_{RTN}$ , $R_{DT} = 24.9\text{ k}\Omega$ , Measure at GATE		74.5%	78.5%	82.5%	
$V_{SYNC}$	Synchronization	Input threshold		2	2.2	2.4	V
<b>FREQUENCY DITHERING RAMP GENERATOR (DTHR)</b>							
$I_{DTRCH}$	Charging (sourcing) current	$0.5\text{ V} < V_{DTHR} < 1.5\text{ V}$	$3 \times I_{FRS}$			$\mu\text{A}$	
			47.2	49.6	52.1	$\mu\text{A}$	
$I_{DTRDC}$	Discharging (sinking) current	$0.5\text{ V} < V_{DTHR} < 1.5\text{ V}$	$3 \times I_{FRS}$			$\mu\text{A}$	
			47.2	49.6	52.1	$\mu\text{A}$	
$V_{DTUT}$	Dithering upper threshold	$V_{DTHR}$ rising until $I_{DTHR} > 0$		1.41	1.513	1.60	V
$V_{DTLT}$	Dithering lower threshold	$V_{DTHR}$ falling until $I_{DTHR} < 0$		0.43	0.487	0.54	V
$V_{DTPP}$	Dithering pk-pk amplitude			1.005	1.026	1.046	V
<b>ERROR AMPLIFIER (FB, COMP)</b>							
$V_{REFC}$	Feedback regulation voltage			1.723	1.75	1.777	V
$I_{FB\_LK}$	FB leakage current (source or sink)	$V_{FB} = 1.75\text{ V}$				0.5	$\mu\text{A}$
$G_{BW}$	Small signal unity gain bandwidth			0.9	1.2		MHz
$A_{OL}$	Open loop voltage gain			70	80		db
$V_{ZDC}$	0% duty-cycle threshold	$V_{COMP}$ falling until GATE switching stops		1.35	1.5	1.65	V



## 7.5 Electrical Characteristics: DC-DC Controller Section (continued)

Unless otherwise noted,  $V_{DD} = 48\text{ V}$ ;  $R_{DEN} = 25.5\text{ k}\Omega$ ;  $R_{FRS} = 60.4\text{ k}\Omega$ ;  $R_{I\_STP} = 499\text{ k}\Omega$ ; CLSA, CLSB, TPH, TPL,  $\overline{BT}$ , SCDIS and PSRS open; CS, EA\_DIS, APD, EMPS, AGND and GND connected to RTN; FB, LINEUV, DT and DTHR connected to VB; PPD connected to VSS;  $C_{VB} = C_{VBG} = 0.1\text{ }\mu\text{F}$ ;  $C_{VCC} = 1\text{ }\mu\text{F}$ ;  $C_{SST} = 0.047\text{ }\mu\text{F}$ ;  $R_{REF} = 49.9\text{ k}\Omega$ ;  $8.5\text{ V} \leq V_{VCC} \leq 16\text{ V}$ ;  $-40^\circ\text{C} \leq T_J \leq 125^\circ\text{C}$ . Positive currents are into pins unless otherwise noted. Typical values are at  $25^\circ\text{C}$ . [ $V_{VSS} = V_{RTN}$ ], all voltages referred to  $V_{RTN}$ ,  $V_{AGND}$  and  $V_{GND}$  unless otherwise noted.

PARAMETER		TEST CONDITIONS	MIN	TYP	MAX	UNIT	
$I_{COMP}$	COMP source current	$V_{FB} = V_{RTN}$ , $V_{COMP} = 3\text{ V}$	1			mA	
$I_{COMPL}$	COMP sink current	$V_{FB} = V_{VB}$ , $V_{COMP} = 1.25\text{ V}$	2.1	6		mA	
$V_{COMPH}$	COMP high voltage	$V_{FB} = V_{RTN}$ , 15 k $\Omega$ from COMP to RTN	4		VB	V	
$V_{COMPL}$	COMP low voltage	$V_{FB} = V_{VB}$ , 15 k $\Omega$ from COMP to VB			1.1	V	
	COMP input resistance, error amplifier disabled	EA_DIS open	70	100	130	k $\Omega$	
	COMP to CS gain	$\Delta V_{CS} / \Delta V_{COMP}$ , $0\text{ V} < V_{CS} < 0.22\text{ V}$	0.19	0.2	0.21	V/V	
<b>SOFT-START, SOFT-STOP (SST, I_STP)</b>							
$I_{SSC}$	Charge current	SST charging, $6.35\text{ V} \leq V_{VCC} \leq 16\text{ V}$	7.5	10	12.5	$\mu\text{A}$	
$I_{SSD}$	Discharge current	SST discharging, $6.35\text{ V} \leq V_{VCC} \leq 16\text{ V}$	3	4	5	$\mu\text{A}$	
$V_{SFST}$	Soft-start lower threshold		0.15	0.2	0.25	V	
$V_{STUOF}$	Startup turn off threshold	$V_{SST}$ rising until VCC startup turns off	1.99	2.1	2.21	V	
$V_{SSOFS}$	Soft-start offset voltage, closed-loop mode	$V_{FB} = V_{RTN}$ , $V_{SST}$ rising until start of switching	0.2	0.25	0.3	V	
	Soft-start offset voltage, peak current mode	$V_{COMP} = V_{VB}$ , $V_{SST}$ rising until start of switching, EA_DIS open	0.55	0.6	0.65	V	
$V_{SSCL}$	Soft-start clamp		2.3		2.6	V	
$I_{SSD\_SP}$	SST discharge current in soft-stop mode	$R_{I\_STP} = 499\text{ k}\Omega$ , $V_{LINEUV} < V_{LIUVF}$	1.5	2	2.5	$\mu\text{A}$	
		$R_{I\_STP} = 16.5\text{ k}\Omega$ , $V_{LINEUV} < V_{LIUVF}$	52.5	60.6	67.5		
$V_{SSTPEN\_D}$	End of soft-stop threshold	$V_{FB} = V_{RTN}$ , $V_{LINEUV} < V_{LIUVF}$	0.15	0.2	0.25	V	
<b>CURRENT SENSE (CS)</b>							
$V_{CSMAX}$	Maximum threshold voltage	$V_{FB} = V_{RTN}$ , $V_{CS}$ rising	0.227	0.25	0.273	V	
$t_{OFFD\_IL}$	Current limit turn off delay	$V_{CS} = 0.3\text{ V}$	25	41	60	ns	
$t_{OFFD\_PW}$	PWM comparator turn off delay	$V_{CS} = 0.15\text{ V}$ , EA_DIS open, $V_{COMP} = 2\text{ V}$	25	41	60	ns	
	Blanking delay	In addition to $t_{OFFD\_IL}$ and $t_{OFFD\_PW}$	75	95	115	ns	
$V_{SLOPE}$	Internal slope compensation voltage	$V_{FB} = V_{RTN}$ , Peak voltage at maximum duty cycle, referred to CS	51	66	79	mV	
$I_{SL\_EX}$	Peak slope compensation current	$V_{FB} = V_{RTN}$ , $I_{CS}$ at maximum duty cycle (ac component)	14	20	26	$\mu\text{A}$	
	Bias current	DC component of CS current	-3	-2	-1	$\mu\text{A}$	
<b>LINE UNDERVOLTAGE, SOFT-STOP (LINEUV)</b>							
$V_{LIUVF}$	LINEUV falling threshold voltage	$V_{LINEUV}$ falling	2.86	2.918	2.976	V	
$V_{LIUVH}$		Hysteresis <sup>(1)</sup>	57	82	107	mV	
	Leakage current	$V_{LINEUV} = 3\text{ V}$			1	$\mu\text{A}$	
<b>DEAD TIME (DT)</b>							
$t_{DT1}$	Dead time	$R_{DT} = 24.9\text{ k}\Omega$ , GAT2 $\uparrow$ to GATE $\uparrow$	$V_{FB} = V_{RTN}$ , $V_{PSRS} = 0\text{ V}$ , EA_DIS open, $V_{COMP} = V_{VB}$ , $C_{GATE} = 1\text{ nF}$ , $C_{GAT2} = 0.5\text{ nF}$ , $V_{VCC} = 10\text{ V}$	40	50	62.5	ns
$t_{DT2}$		$R_{DT} = 24.9\text{ k}\Omega$ , GATE $\downarrow$ to GAT2 $\downarrow$		40	50	62.5	
$t_{DT1}$		$R_{DT} = 75\text{ k}\Omega$ , GAT2 $\uparrow$ to GATE $\uparrow$		120	150	188	
$t_{DT2}$		$R_{DT} = 75\text{ k}\Omega$ , GATE $\downarrow$ to GAT2 $\downarrow$		120	150	188	

## 7.5 Electrical Characteristics: DC-DC Controller Section (continued)

Unless otherwise noted,  $V_{DD} = 48\text{ V}$ ;  $R_{DEN} = 25.5\text{ k}\Omega$ ;  $R_{FRS} = 60.4\text{ k}\Omega$ ;  $R_{L\_STP} = 499\text{ k}\Omega$ ; CLSA, CLSB, TPH, TPL,  $\overline{BT}$ , SCDIS and PSRS open; CS, EA\_DIS, APD, EMPS, AGND and GND connected to RTN; FB, LINEUV, DT and DTHR connected to VB; PPD connected to VSS;  $C_{VB} = C_{VBG} = 0.1\text{ }\mu\text{F}$ ;  $C_{VCC} = 1\text{ }\mu\text{F}$ ;  $C_{SST} = 0.047\text{ }\mu\text{F}$ ;  $R_{REF} = 49.9\text{ k}\Omega$ ;  $8.5\text{ V} \leq V_{VCC} \leq 16\text{ V}$ ;  $-40^\circ\text{C} \leq T_J \leq 125^\circ\text{C}$ . Positive currents are into pins unless otherwise noted. Typical values are at  $25^\circ\text{C}$ . [ $V_{VSS} = V_{RTN}$ ], all voltages referred to  $V_{RTN}$ ,  $V_{AGND}$  and  $V_{GND}$  unless otherwise noted.

PARAMETER		TEST CONDITIONS	MIN	TYP	MAX	UNIT
<b>GATE</b>						
	Peak source current	$V_{FB} = V_{RTN}$ , $V_{VCC} = 10\text{ V}$ , $V_{GATE} = 0\text{ V}$ , pulsed measurement	0.3	0.5	0.8	A
	Peak sink current	$V_{FB} = V_{RTN}$ , $V_{VCC} = 10\text{ V}$ , $V_{GATE} = 10\text{ V}$ , pulsed measurement	0.6	0.9	1.45	A
	Rise time <sup>(2)</sup>	$t_{pr10-90}$ , $C_{GATE} = 1\text{ nF}$ , $V_{VCC} = 10\text{ V}$		30		ns
	Fall time <sup>(2)</sup>	$t_{pff90-10}$ , $C_{GATE} = 1\text{ nF}$ , $V_{VCC} = 10\text{ V}$		15		ns
<b>GAT2</b>						
	Peak source current	$V_{FB} = V_{RTN}$ , $V_{VCC} = 10\text{ V}$ , $R_{DT} = 24.9\text{ k}\Omega$ , $V_{GAT2} = 0\text{ V}$ , pulsed measurement	0.3	0.5	0.8	A
	Peak sink current	$V_{FB} = V_{RTN}$ , $V_{VCC} = 10\text{ V}$ , $R_{DT} = 24.9\text{ k}\Omega$ , $V_{GAT2} = 10\text{ V}$ , pulsed measurement	0.3	0.45	0.72	A
	Rise time <sup>(2)</sup>	$t_{pr10-90}$ , $C_{GAT2} = 0.5\text{ nF}$ , $V_{VCC} = 10\text{ V}$		15		ns
	Fall time <sup>(2)</sup>	$t_{pff90-10}$ , $C_{GAT2} = 0.5\text{ nF}$ , $V_{VCC} = 10\text{ V}$		15		ns
<b>CLAMPING FET (CP)</b>						
$R_{DS(ON)CL}$	CP FET on resistance	$I_{CP} = 100\text{ mA}$		1.5	3.3	$\Omega$
<b>CLAMPING DIODE (CP)</b>						
$V_{FCP}$	CP Diode forward voltage	$V_{PSRS} = 0\text{ V}$ , $I_{CP} = 15\text{ mA}$	0.45	0.6	0.85	V
	CP Leakage current	$V_{PSRS} = 0\text{ V}$ , $V_{CP} = 45\text{ V}$			20	$\mu\text{A}$
<b>AUXILIARY POWER DETECTION (APD)</b>						
$V_{APDEN}$	APD threshold voltage	$V_{APD}$ rising	1.42	1.5	1.58	V
$V_{APDH}$		Hysteresis <sup>(1)</sup>	0.075	0.095	0.115	V
	Leakage current	$V_{APD} = 5\text{ V}$			1	$\mu\text{A}$
<b>PPD</b>						
$V_{PPDEN}$	PPD threshold voltage	$V_{VDD} > 16\text{ V}$ , $V_{PPD} - V_{VSS}$ rising, PD input UVLO disable	2.34	2.5	2.66	V
$V_{PPDH}$		Hysteresis <sup>(1)</sup>	0.47	0.5	0.53	
$I_{PPD}$	PPD sink current	$V_{PPD} - V_{VSS} = 3\text{ V}$	2.5	5	7.5	$\mu\text{A}$
<b>THERMAL SHUTDOWN</b>						
	Turnoff temperature		145	155	165	$^\circ\text{C}$
	Hysteresis <sup>(2)</sup>			15		$^\circ\text{C}$

(1) The hysteresis tolerance tracks the rising threshold for a given device.

(2) These parameters are provided for reference only, and do not constitute part of TI's published device specifications for purposes of TI's product warranty.

## 7.6 Electrical Characteristics PoE

Unless otherwise noted,  $V_{DD} = 48\text{ V}$ ;  $R_{DEN} = 25.5\text{ k}\Omega$ ;  $R_{FRS} = 60.4\text{ k}\Omega$ ;  $R_{I\_STP} = 499\text{ k}\Omega$ ; CLSA, CLSB, TPH, TPL, BT, SCDIS and PSRS open; CS, EA\_DIS, APD, EMPS, AGND and GND connected to RTN; FB, LINEUV, DT and DTHR connected to VB; PPD connected to VSS;  $C_{VB} = C_{VBG} = 0.1\text{ }\mu\text{F}$ ;  $C_{VCC} = 1\text{ }\mu\text{F}$ ;  $C_{SST} = 0.047\text{ }\mu\text{F}$ ;  $R_{REF} = 49.9\text{ k}\Omega$ ;  $-40^\circ\text{C} \leq T_J \leq 125^\circ\text{C}$ . Positive currents are into pins unless otherwise noted. Typical values are at  $25^\circ\text{C}$ .  $V_{VCC-RTN} = 0\text{ V}$ , all voltages referred to  $V_{VSS}$  unless otherwise noted.

PARAMETER	TEST CONDITIONS	MIN	TYP	MAX	UNIT		
<b>PD DETECTION (DEN)</b>							
	Detection bias current	DEN open, $V_{DD} = 10\text{ V}$ , Not in mark, Measure $I_{VDD} + I_{RTN}$		3.5	6.9	13.9	$\mu\text{A}$
$I_{IKG}$	DEN leakage current	$V_{DEN} = V_{DD} = 60\text{ V}$ , Float RTN, Measure $I_{DEN}$			0.1	5	$\mu\text{A}$
	Detection current	Measure $I_{VDD} + I_{DEN} + I_{RTN}$ , $V_{DD} = 1.4\text{ V}$		53.5	56.5	58.6	$\mu\text{A}$
		Measure $I_{VDD} + I_{DEN} + I_{RTN}$ , $V_{DD} = 10\text{ V}$ , Not in mark		391	398	406.2	$\mu\text{A}$
$V_{PD\_DIS}$	Hotswap disable threshold	DEN falling		3	4	5	V
<b>PD CLASSIFICATION (CLSA, CLSB)</b>							
$I_{CLS}$	Classification A, B signature current	$R_{CLSA}$ or $R_{CLSB} = 806\text{ }\Omega$	$13\text{ V} \leq V_{DD} \leq 21\text{ V}$ , Measure $I_{VDD} + I_{DEN} + I_{RTN}$	1.9	2.5	2.9	mA
		$R_{CLSA}$ or $R_{CLSB} = 130\text{ }\Omega$	$13\text{ V} \leq V_{DD} \leq 21\text{ V}$ , Measure $I_{VDD} + I_{DEN} + I_{RTN}$	9.9	10.6	11.3	mA
		$R_{CLSA}$ or $R_{CLSB} = 69.8\text{ }\Omega$	$13\text{ V} \leq V_{DD} \leq 21\text{ V}$ , Measure $I_{VDD} + I_{DEN} + I_{RTN}$	17.6	18.6	19.4	mA
		$R_{CLSA}$ or $R_{CLSB} = 46.4\text{ }\Omega$	$13\text{ V} \leq V_{DD} \leq 21\text{ V}$ , Measure $I_{VDD} + I_{DEN} + I_{RTN}$	26.5	27.9	29.3	mA
		$R_{CLSA}$ or $R_{CLSB} = 32\text{ }\Omega$	$13\text{ V} \leq V_{DD} \leq 21\text{ V}$ , Measure $I_{VDD} + I_{DEN} + I_{RTN}$	37.8	39.9	42	mA
$V_{CL\_ON}$	Classification regulator lower threshold rising	$V_{DD}$ rising, $I_{CLS} \uparrow$		11.4	12.2	13	V
$V_{CL\_H}$	Classification regulator lower threshold	Hysteresis <sup>(1)</sup>		0.8	1.2	1.6	V
$V_{CU\_OFF}$	Classification regulator upper threshold	$V_{DD}$ rising, $I_{CLS} \downarrow$		21	22	23	V
$V_{CU\_H}$		Hysteresis <sup>(1)</sup>		0.5	0.77	1	V
$V_{MSR}$	Mark state reset threshold	$V_{DD}$ falling		3	3.9	5	V
	Mark state resistance	2-point measurement at 5 V and 10.1 V		6	10	12	k $\Omega$
$I_{IKG}$	Leakage current	$V_{DD} = 60\text{ V}$ , $V_{CLS} = 0\text{ V}$ , $V_{DEN} = V_{VSS}$ , Measure $I_{CLS}$				1	$\mu\text{A}$
$t_{LCF\_PD}$	Long first class event timing	Class 1st event time duration for short MPS		76	81.5	87	ms
<b>RTN (PASS DEVICE)</b>							
	ON-resistance			0.3	0.55		$\Omega$
$I_{LIM}$	Current limit	$V_{RTN} = 1.5\text{ V}$ , pulsed measurement		1.5	1.85	2.2	A
$I_{IRSH}$	inrush current limit	$V_{RTN} = 2\text{ V}$ , $V_{DD}$ : $20\text{ V} \rightarrow 48\text{ V}$ , measure $I_{RTN}$ , pulsed measurement		100	140	180	mA
	Inrush current limit with nonstandard UVLO	$V_{PPD} - V_{VSS} > V_{PPDEN}$ , $V_{RTN} = 2\text{ V}$ , $V_{DD}$ : $0\text{ V} \rightarrow 20\text{ V}$ , measure $I_{RTN}$ , pulsed measurement		100	140	180	mA
	Inrush termination	Percentage of inrush current.		80%	90%	99%	
$t_{INR\_DEL}$		Inrush delay		80	84	88	ms

## 7.6 Electrical Characteristics PoE (continued)

Unless otherwise noted,  $V_{DD} = 48\text{ V}$ ;  $R_{DEN} = 25.5\text{ k}\Omega$ ;  $R_{FRS} = 60.4\text{ k}\Omega$ ;  $R_{L\_STP} = 499\text{ k}\Omega$ ; CLSA, CLSB, TPH, TPL,  $\overline{\text{BT}}$ , SCDIS and PSRS open; CS, EA\_DIS, APD, EMPS, AGND and GND connected to RTN; FB, LINEUV, DT and DTHR connected to VB; PPD connected to VSS;  $C_{VB} = C_{VBG} = 0.1\text{ }\mu\text{F}$ ;  $C_{VCC} = 1\text{ }\mu\text{F}$ ;  $C_{SST} = 0.047\text{ }\mu\text{F}$ ;  $R_{REF} = 49.9\text{ k}\Omega$ ;  $-40^\circ\text{C} \leq T_J \leq 125^\circ\text{C}$ . Positive currents are into pins unless otherwise noted. Typical values are at  $25^\circ\text{C}$ .

$V_{VCC-RTN} = 0\text{ V}$ , all voltages referred to  $V_{VSS}$  unless otherwise noted.

PARAMETER		TEST CONDITIONS		MIN	TYP	MAX	UNIT
	Foldback voltage threshold	$V_{RTN}$ rising		13.5	14.8	16.1	V
	Foldback deglitch time	$V_{RTN}$ rising to when current limit changes to inrush current limit. This applies in normal operating condition or during auto MPS mode.		1.5	1.8	2.1	ms
	Leakage current	$V_{DD} = V_{RTN} = 100\text{ V}$ , $V_{DEN} = V_{VSS}$				70	$\mu\text{A}$
<b>PSE TYPE INDICATION (TPL, TPH, BT)</b>							
$V_{TPL}$	Output low voltage	$I_{TPL} = 1\text{ mA}$ , after 2- or 3-event classification, startup has completed, $V_{RTN} = 0\text{ V}$			0.27	0.5	V
$V_{TPH}$	Output low voltage	$I_{TPH} = 1\text{ mA}$ , after 4-event classification, startup has completed, $V_{RTN} = 0\text{ V}$			0.27	0.5	V
$V_{BT}$	Output low voltage	$I_{BT} = 2\text{ mA}$ , after IEEE802.3bt classification, startup has completed, $V_{RTN} = 0\text{ V}$			0.27	0.5	V
$f_{TPL}$	TPL frequency	$V_{SCDIS} = 0\text{ V}$ , $V_{APD-RTN} = 5\text{ V}$ , after startup has completed.		550	625	700	Hz
	TPL duty cycle in PoE operation	$V_{SCDIS} = 0\text{ V}$ , after 4-event classification, after startup has completed		24%	25%	26%	
	TPL duty cycle in nonstandard PoE operation	$V_{SCDIS} = 0\text{ V}$ , after startup has completed		49%	50%	51%	
	TPL duty cycle in auxiliary supply operation	$V_{SCDIS} = 0\text{ V}$ , $V_{APD-RTN} = 5\text{ V}$ , after startup has completed.		74%	75%	76%	
	Leakage current	$V_{TPL-RTN}$ or $V_{TPH-RTN} = 10\text{ V}$ or $V_{BT-RTN} = 5\text{ V}$ , $V_{RTN} = 0\text{ V}$				1	$\mu\text{A}$
	SCDIS pullup current	$V_{DD} \geq V_{UVLO\_R}$ or $V_{APD-RTN} = 5\text{ V}$		14	20	25	$\mu\text{A}$
<b>PD INPUT SUPPLY (VDD)</b>							
$V_{UVLO\_R}$	Undervoltage lockout threshold	$V_{DD}$ rising		35.8	37.6	39.5	V
$V_{UVLO\_F}$	Undervoltage lockout threshold	$V_{DD}$ falling		30.5	32	33.6	V
$V_{UVLO\_H}$	Undervoltage lockout threshold	Hysteresis <sup>(1)</sup>		5.7	6.0	6.3	V
$I_{VDD\_ON}$	Operating current	40 V $\leq V_{DD} \leq$ 60 V, Startup completed, $V_{VCC} = 10\text{ V}$ , Measure $I_{VDD}$			650	1040	$\mu\text{A}$
$I_{VDD\_OFF}$	Off-state current	RTN, GND and VCC open, $V_{DD} = 30\text{ V}$ , Measure $I_{VDD}$				730	$\mu\text{A}$
<b>MPS</b>							
$I_{MPSL}$	MPS total VSS current for Type 1-2 PSE	EMPS open, inrush delay has completed, 0 mA $\leq I_{RTN} \leq$ 10 mA, measure $I_{VSS}$		10	12.5	15.5	mA
$I_{MPSH}$	MPS total VSS current for Type 3-4 PSE	EMPS open, inrush delay has completed, 0 mA $\leq I_{RTN} \leq$ 16 mA, measure $I_{VSS}$		16.25	19	21.5	mA
		MPS pulsed current duty-cycle	EMPS open	26.2%	26.6%	26.9%	
$t_{MPSL}$	MPS pulsed mode duty cycle for Type 1-2 PSE	MPS pulsed current ON time	EMPS open	76	81.5	87	ms
		MPS pulsed current OFF time	EMPS open		225	245	ms

## 7.6 Electrical Characteristics PoE (continued)

Unless otherwise noted,  $V_{DD} = 48\text{ V}$ ;  $R_{DEN} = 25.5\text{ k}\Omega$ ;  $R_{FRS} = 60.4\text{ k}\Omega$ ;  $R_{I\_STP} = 499\text{ k}\Omega$ ; CLSA, CLSB, TPH, TPL,  $\overline{\text{BT}}$ , SCDIS and PSRS open; CS, EA\_DIS, APD, EMPS, AGND and GND connected to RTN; FB, LINEUV, DT and DTHR connected to VB; PPD connected to VSS;  $C_{VB} = C_{VBG} = 0.1\text{ }\mu\text{F}$ ;  $C_{VCC} = 1\text{ }\mu\text{F}$ ;  $C_{SST} = 0.047\text{ }\mu\text{F}$ ;  $R_{REF} = 49.9\text{ k}\Omega$ ;  $-40^\circ\text{C} \leq T_J \leq 125^\circ\text{C}$ . Positive currents are into pins unless otherwise noted. Typical values are at  $25^\circ\text{C}$ .  $V_{VCC-RTN} = 0\text{ V}$ , all voltages referred to  $V_{VSS}$  unless otherwise noted.

PARAMETER		TEST CONDITIONS		MIN	TYP	MAX	UNIT
$t_{\text{MPSH}}$	MPS pulsed mode duty-cycle for Type 3-4 PSE	MPS pulsed current duty-cycle, no pulse stretching	EMPS open	2.9%	3.0%	3.1%	
		MPS pulsed current ON time, no pulse stretching	EMPS open	7.2	7.7	8.1	ms
		MPS pulsed current OFF time	EMPS open	238	250	265	ms
		MPS pulsed current ON time stretching limit	EMPS open	54	57	62	ms
<b>THERMAL SHUTDOWN</b>							
	Turnoff temperature			148	158	168	$^\circ\text{C}$
	Hysteresis <sup>(2)</sup>				15		$^\circ\text{C}$

- (1) The hysteresis tolerance tracks the rising threshold for a given device.  
 (2) These parameters are provided for reference only.

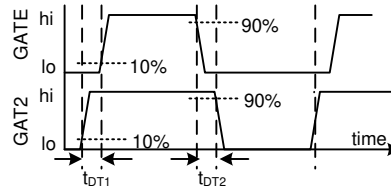

**Figure 7-1. GATE and GAT2 Timing and Phasing**

## 7.7 Typical Characteristics

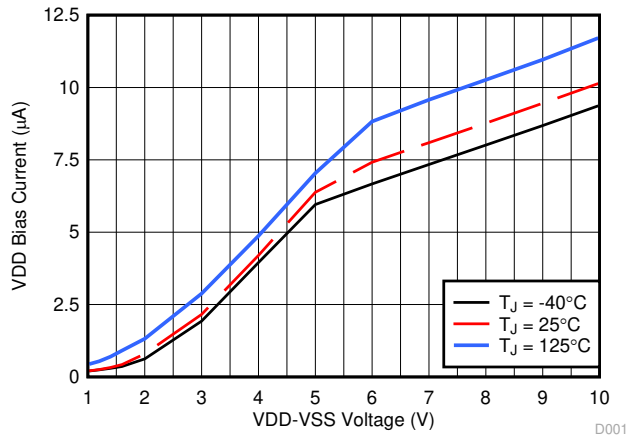

Figure 7-2. Detection Bias Current vs Voltage

D001

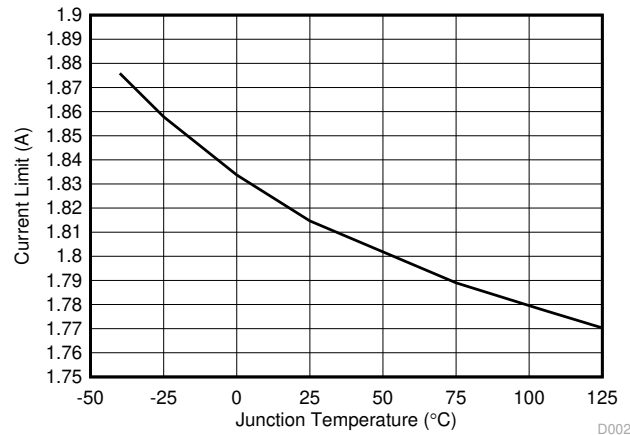

Figure 7-3. PoE Current Limit vs Temperature

D002

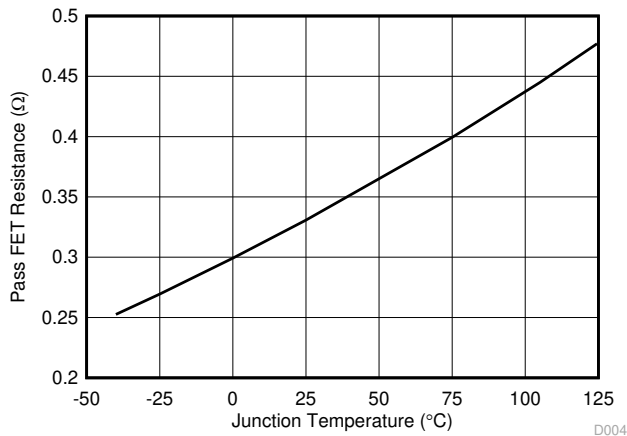

Figure 7-4. Pass FET Resistance vs Temperature

D004

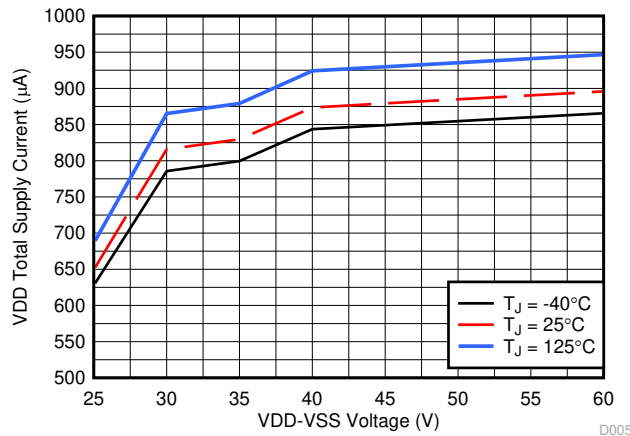

Figure 7-5. VDD Supply Current vs Voltage

D005

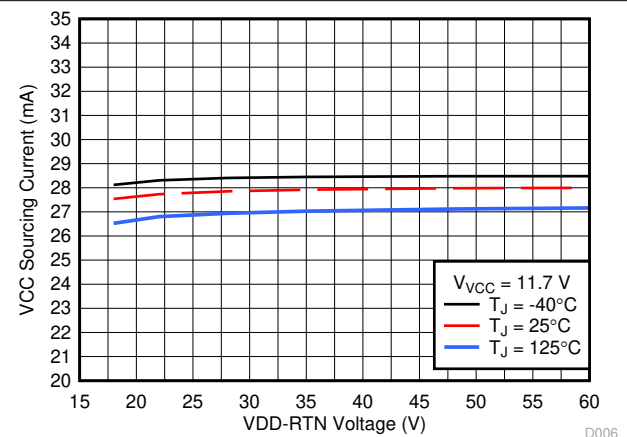

Figure 7-6. Converter Startup Current vs VDD Input Voltage

D006

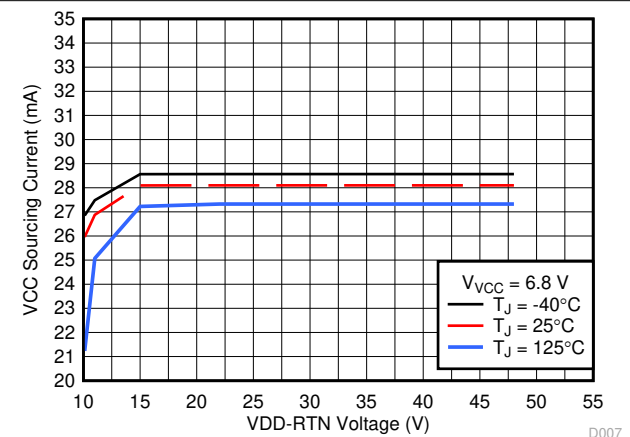
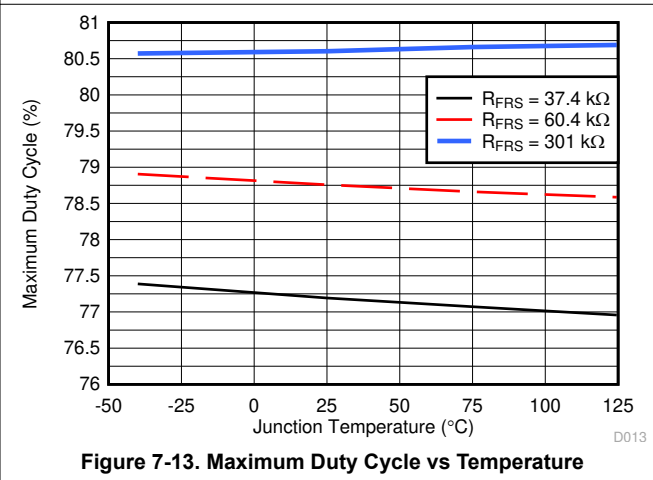
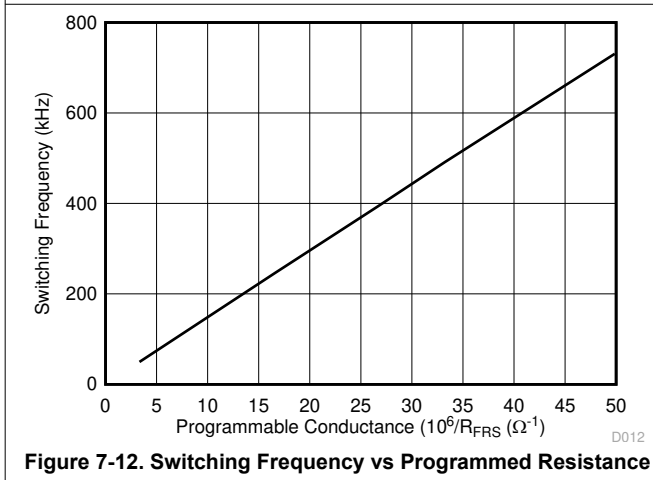
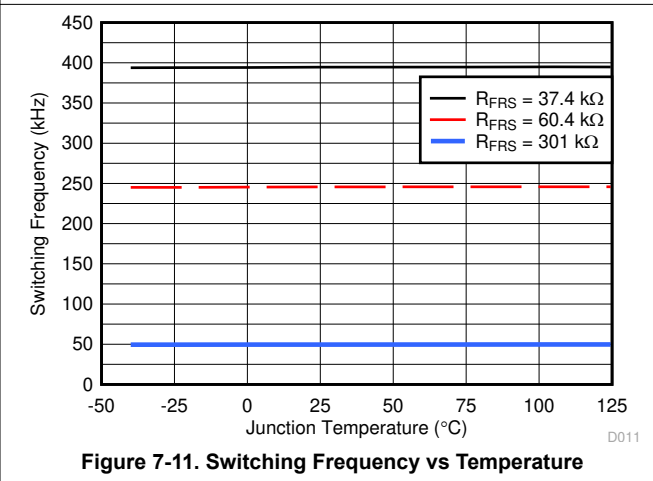
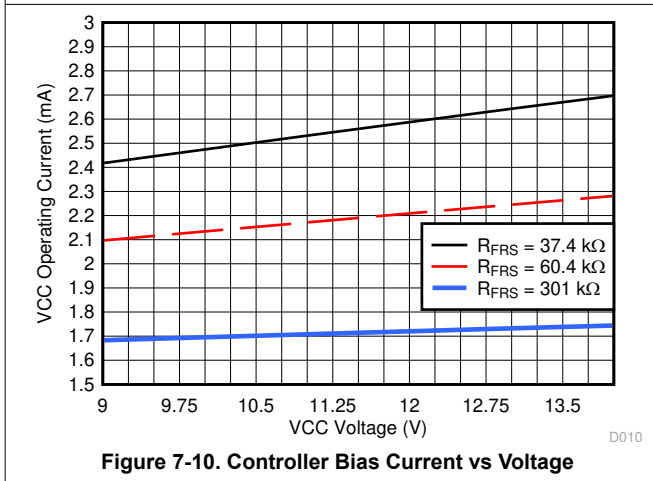
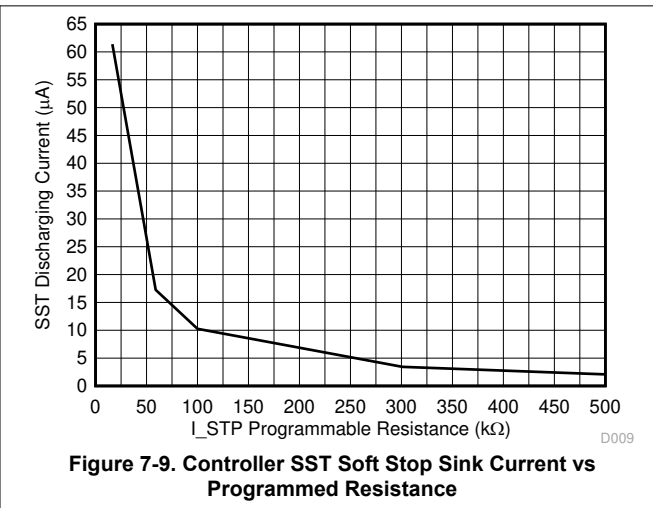
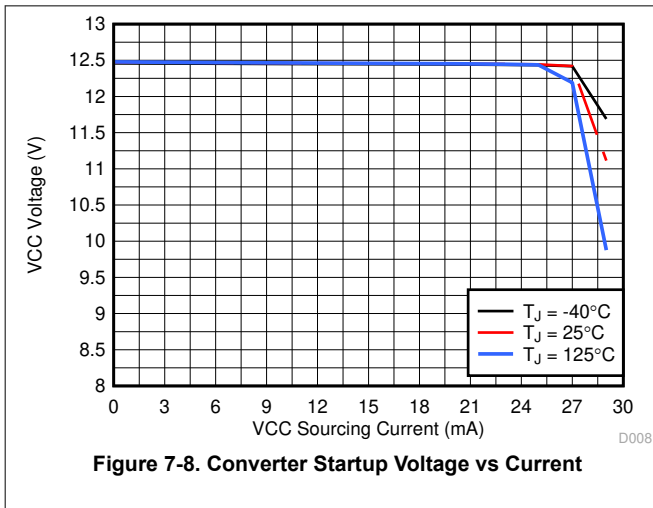

Figure 7-7. Converter Startup Current vs VDD Input Voltage

D007

### 7.7 Typical Characteristics (continued)



### 7.7 Typical Characteristics (continued)

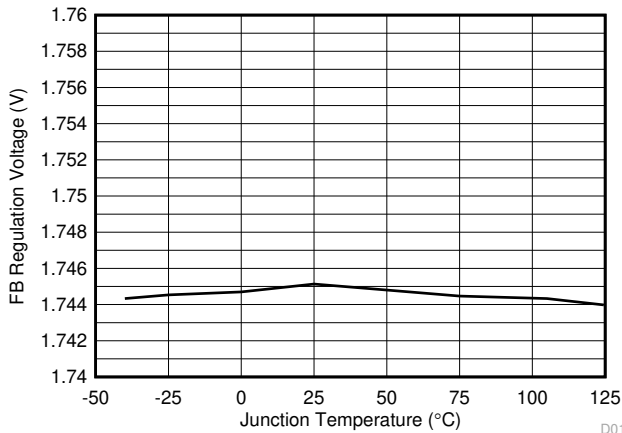

Figure 7-14. Feedback Regulation Voltage vs Temperature

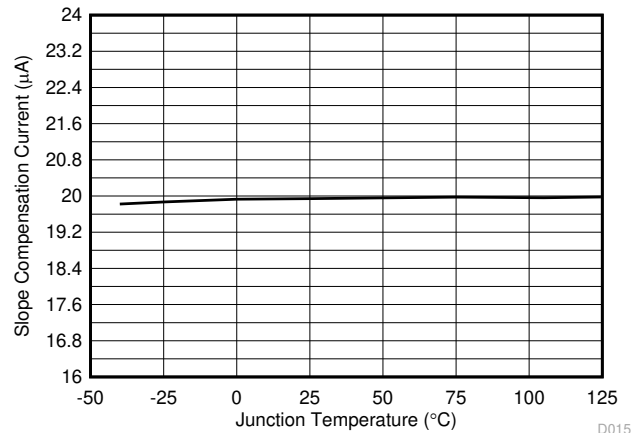

Figure 7-15. Current Slope Compensation Current vs Temperature

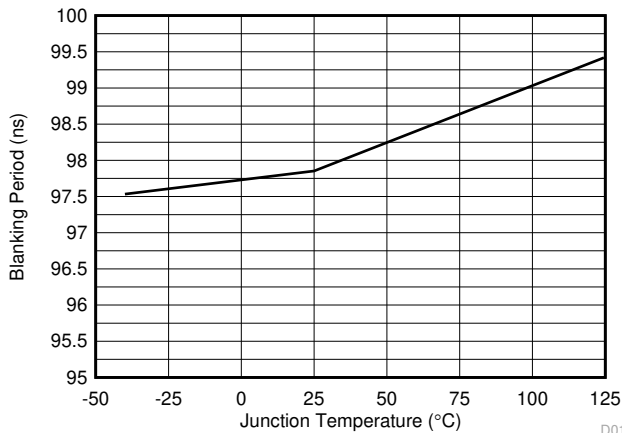

Figure 7-16. Blanking Period vs Temperature

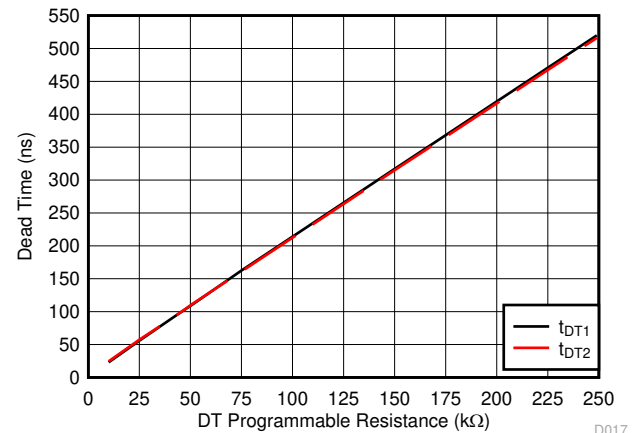

Figure 7-17. Dead Time vs Dead Time Resistance ( $R_{DT}$ )

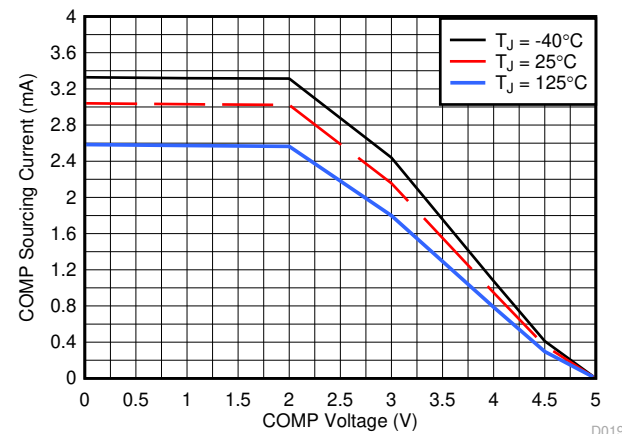

Figure 7-18. Error Amplifier Source Current

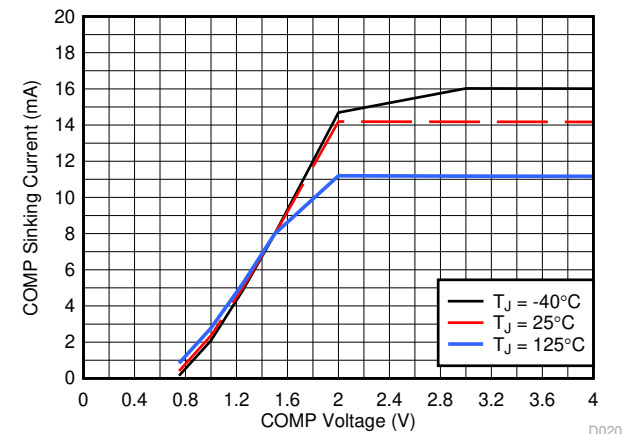
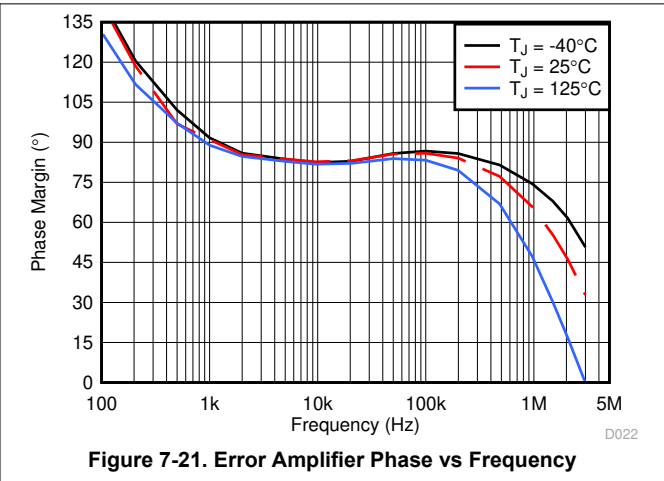
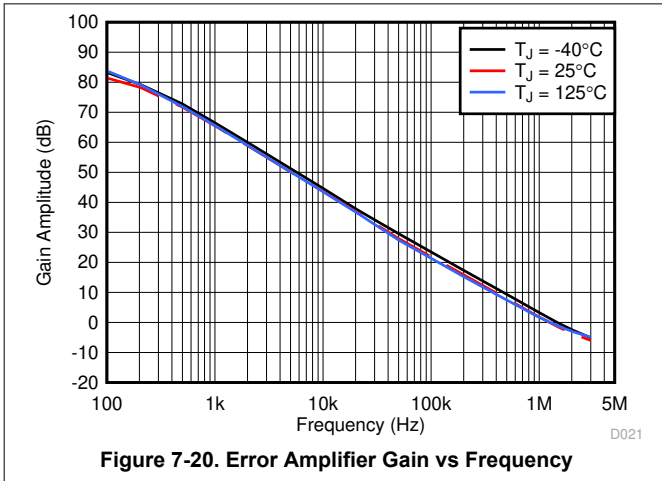

Figure 7-19. Error Amplifier Sink Current



### 7.7 Typical Characteristics (continued)



## 8 Detailed Description

### 8.1 Overview

The TPS23730 device is a 45-pin integrated circuit that contains all of the features needed to implement a single interface IEEE 802.3bt Type 3 Class 1-6 and IEEE802.3at powered device (PD), combined with a current-mode DC-DC controller optimized for flyback and active clamp forward switching regulator design.

The DC-DC controller of the TPS23730 features two complementary gate drivers with programmable dead time. This simplifies the design of active-clamp forward converters or optimized gate drive for highly-efficient flyback topologies. The second gate driver may be disabled if desired for self-driven synchronous flyback or for single MOSFET topologies.

Basic PoE PD functionality supported includes detection, hardware classification, and inrush current limit during startup. DC-DC converter features include startup function and current mode control operation. The TPS23730 device integrates a low 0.3- $\Omega$  internal switch to minimize heat dissipation and maximize power utilization.

A number of input voltage Oring options or input voltage ranges are also supported by use of APD and PPD inputs.

The TPS23730 device contains several protection features such as thermal shutdown, current limit foldback, and a robust 100-V internal return switch.

## 8.2 Functional Block Diagram

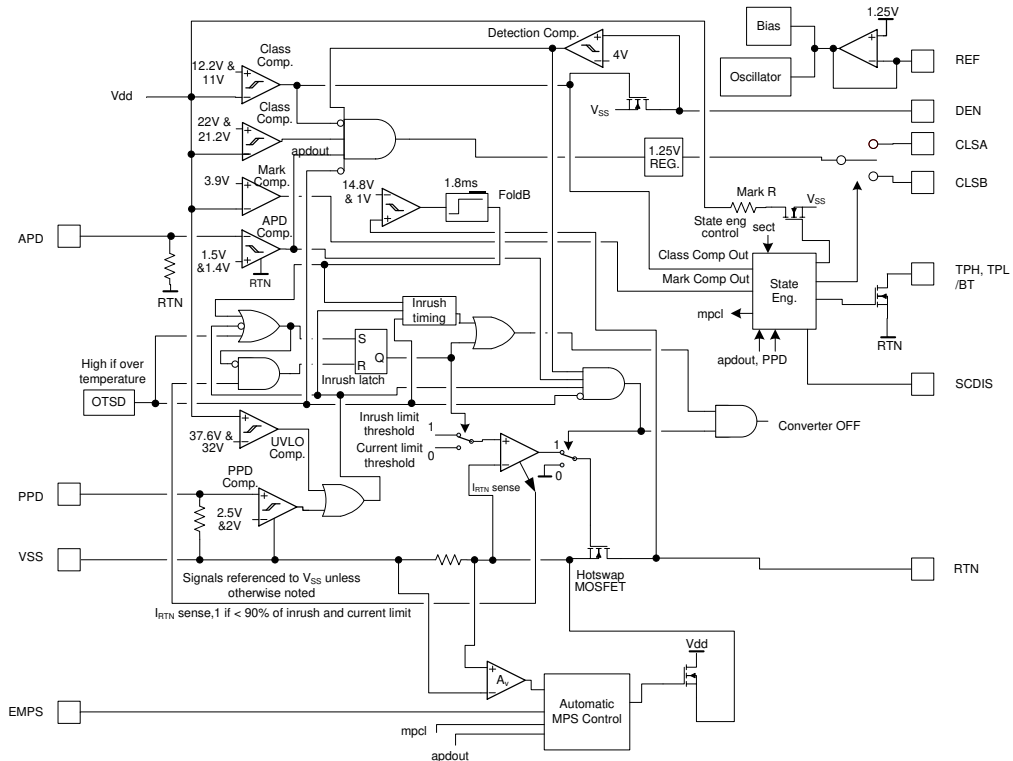
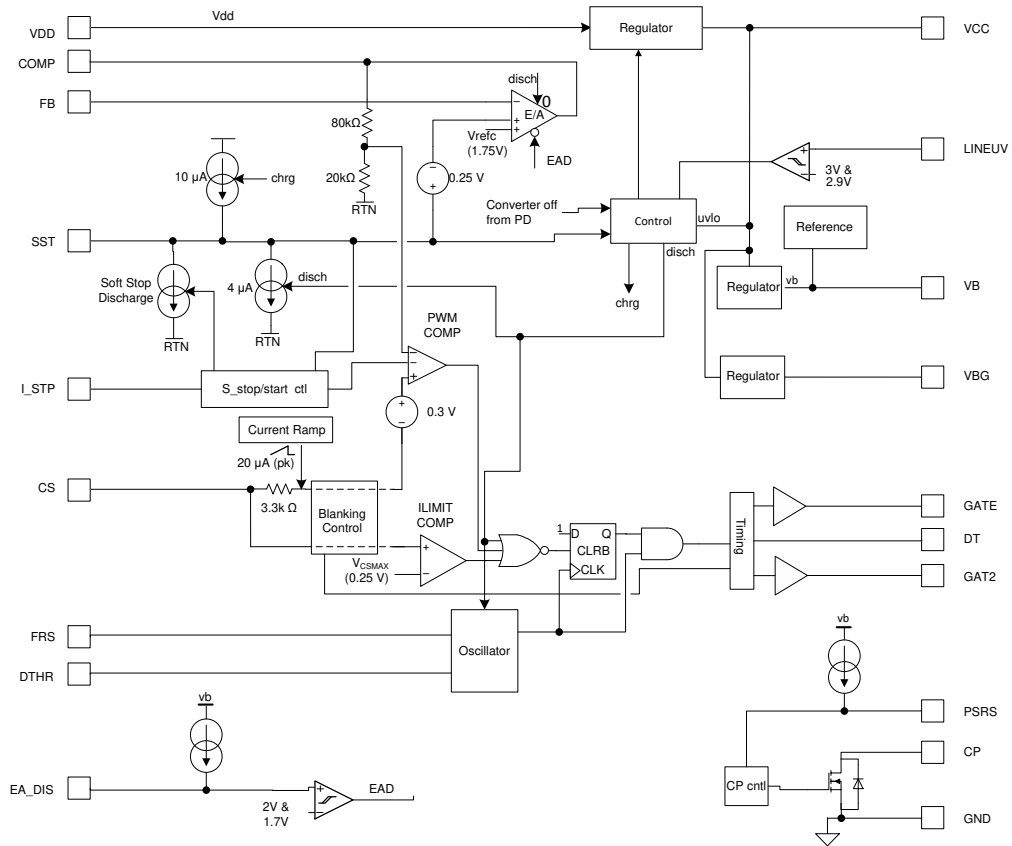

## 8.3 Feature Description

See [Figure 9-1](#) for component reference designators ( $R_{CS}$  for example), and [Electrical Characteristics: DC-DC Controller Section](#) for values denoted by reference ( $V_{CSMAX}$  for example). Electrical Characteristic values take precedence over any numerical values used in the following sections.

### 8.3.1 CLSA, CLSB Classification

Each of the two external resistors ( $R_{CLSA}$  and  $R_{CLSB}$  in [Figure 9-1](#)) connected between the CLSA (first and second class event) and CLSB (third and any subsequent class event) pins and VSS provide a distinct classification signature to the PSE, and are used to define the power class requested by the PD. The controller places a voltage of approximately 1.25 V across CLSA (first or second class event) or CLSB (all additional class events) external resistor whenever the voltage differential between VDD and VSS lies from about 11 V to 22 V. The current drawn by each resistor, combined with the internal current drain of the controller and any leakage through the internal pass MOSFET, creates the classification signature current. [Table 8-1](#) lists the external resistor values required for each of the PD power ranges defined by IEEE802.3bt. The number of classification cycles then determines how much power is allocated by the PSE. The maximum average power drawn by the PD, plus the power supplied to the downstream load, should not exceed the maximum power indicated in [Table 8-1](#), as well as the maximum power allocated by the PSE based on the number of classification cycles. Holding APD high disables the classification signatures.

Type 2 and Type 3 PSEs may perform two classification cycles if Class 4 signature is presented on the first cycle. Likewise, Type 3 and Type 4 PSEs may perform four classification cycles if Class 4 signature is presented on the first two cycles and Class 0 or 1 signature is presented on the third cycle.

**Table 8-1. Class Resistor Selection**

PD CLASS	CLASS SIGNATURE A	CLASS SIGNATURE B	MINIMUM POWER AT PD (W)	MAXIMUM POWER AT PD (W)	NUMBER OF CLASS CYCLES @ MAX POWER	RESISTOR CLSA ( $\Omega$ )	RESISTOR CLSB ( $\Omega$ )
0	0	0	0.44	12.95	1	806	806
1	1	1	0.44	3.84	1	130	130
2	2	2	3.84	6.49	1	69.8	69.8
3	3	3	6.49	12.95	1	46.4	46.4
4	4	4	12.95	25.5	2,3	32	32
5	4	0	25.5	40	4	32	806
6	4	1	40	51	4	32	130

### 8.3.2 DEN Detection and Enable

DEN pin implements two separate functions. A resistor ( $R_{DEN}$  in [Figure 9-1](#)) connected between VDD and DEN generates a detection signature whenever the voltage differential between VDD and VSS lies from approximately 1.4 to 10.9 V. Beyond this range, the controller disconnects this resistor to save power. The IEEE 802.3bt and IEEE 802.3at standards specify a detection signature resistance,  $R_{detect}$  from 23.75 k $\Omega$  to 26.25 k $\Omega$ , or 25 k $\Omega \pm 5\%$ . TI recommends a resistor of 25.5 k $\Omega \pm 1\%$  for  $R_{DEN}$ .

Pulling DEN to VSS during powered operation causes the internal hotswap MOSFET and class regulator to turn off. If the resistance connected between VDD and DEN is divided into two roughly equal portions, then the application circuit can disable the PD by grounding the tap point between the two resistances, while simultaneously spoiling the detection signature which prevents the PD from properly re-detecting.

### 8.3.3 APD Auxiliary Power Detect

The APD pin is used in applications that may draw power either from the Ethernet cable or from an auxiliary power source. When a voltage of more than about 1.5 V is applied on the APD pin relative to RTN, the TPS23730 does the following:

- Internal pass MOSFET is turned off
- Classification current is disabled

- The LINEUV input is disabled
- Maintain Power Signature (MPS) pulsed mode is disabled
- TPH and TPL outputs are turned on (low state) if SCDIS is open
- TPL duty-cycle becomes 75% if SCDIS level is low

This also gives adapter source priority over the PoE. A resistor divider ( $R_{APD1}$ – $R_{APD2}$  in [Figure 9-1](#)) provides system-level ESD protection for the APD pin, discharges leakage from the blocking diode ( $D_A$  in [Figure 9-1](#)) and provides input voltage supervision to ensure that switch-over to the auxiliary voltage source does not occur at excessively low voltages. If not used, connect APD to RTN.

### 8.3.4 PPD Power Detect

PPD permits power to come from an external low voltage adapter, for example 24 V, connected from VDD to VSS by overriding the normal hotswap UVLO. Voltage on PPD more than 2.5 V ( $V_{PPDEN}$ ) enables the hotswap MOSFET, inhibits class current, and turns on TPH and TPL. A resistor divider per [Figure 8-16](#) provides ESD protection, leakage discharge for the adapter ORing diode, reverse adapter protection, and input voltage qualification. Voltage qualification assures the adapter output voltage is high enough that it can support the PD before it begins to draw current

The PPD pin has a 5- $\mu$ A internal pulldown current.

Locate the PPD pulldown resistor adjacent to the pin when used. PPD may be tied to VSS pin or left open when not used.

### 8.3.5 Internal Pass MOSFET

RTN pin provides the negative power return path for the load. It is internally connected to the drain of the PoE hotswap MOSFET, and the DC-DC controller return. RTN must be treated as a local reference plane (ground plane) for the DC-DC controller and converter primary to maintain signal integrity.

Once  $V_{VDD}$  exceeds the UVLO threshold, the internal pass MOSFET pulls RTN to VSS. Inrush limiting prevents the RTN current from exceeding a nominal value of about 140 mA until the bulk capacitance ( $C_{BULK}$  in [Figure 9-1](#)) is fully charged. Two conditions must be met to reach the end of inrush phase. The first one is when the RTN current drops below about 90% of nominal inrush current at which point the current limit is changed to 1.85 A, while the second one is to ensure a minimum inrush delay period of 80 ms ( $t_{INR\_DEL}$ ) from beginning of the inrush phase. DC-DC converter switching is permitted once both inrush conditions are met, meaning that the bulk capacitance is fully charged and the inrush period has been completed.

If  $V_{RTN} - V_{VSS}$  ever exceeds about 14.8 V for longer than 1.8 ms, then the PD returns to inrush limiting; note that in this particular case, the second condition described above about inrush phase duration (80 ms) is not applicable

### 8.3.6 TPH, TPL and $\overline{BT}$ PSE Type Indicators

The state of TPH and TPL is used to provide information relative to the allocated power. The encoding can be either parallel or serial (TPL only), selectable with SCDIS input. [Table 8-2](#) lists the parallel encoding corresponding to various combinations of PSE Type, PD Class and allocated power. The allocated power is determined by the number of classification cycles having been received. The PSE may also allocate a lower power than what the PD is requesting, in which case there is power demotion. The  $\overline{BT}$  output also indicates if a PSE applying an IEEE802.3bt (Type 3 or 4) mutual identification scheme has been identified.

Serial encoding can be selected by tying SCDIS to VSS. See [Table 8-3](#) which lists the TPL serial encoding versus allocated power. In this case, TPH becomes high impedance.

**Table 8-2. TPH, TPL and Allocated Power Truth Table, with APD and PPD Low, SCDIS Open**

PSE TYPE	PD CLASS	NUMBER OF CLASS CYCLES	PSE ALLOCATED POWER AT PD (W)	TPH <sup>(2)</sup>	TPL
1-4	0	1	12.95	HIGH	HIGH
1-4	1	1	3.84	HIGH	HIGH
1-4	2	1	6.49	HIGH	HIGH
1-4	3	1	12.95	HIGH	HIGH

**Table 8-2. TPH, TPL and Allocated Power Truth Table, with APD and PPD Low, SCDIS Open (continued)**

PSE TYPE	PD CLASS	NUMBER OF CLASS CYCLES	PSE ALLOCATED POWER AT PD (W)	TPH <sup>(2)</sup>	TPL
2	4	2	25.5	HIGH	LOW
3-4	4	2-3	25.5	HIGH	LOW
3-4	5	4	40	LOW	HIGH
3-4	6	4	51	LOW	HIGH
PoE++	5,6	-	-	LOW <sup>(1)</sup>	HIGH

- (1) If PoE++ PSE, the  $\overline{BT}$  output is also high.  
(2) If APD or PPD is high, both TPH and TPL outputs become low.

**Table 8-3. TPL Duty-Cycle and Allocated Power Truth Table, with APD and PPD Low, SCDIS Low**

PSE TYPE	PD CLASS	NUMBER OF CLASS CYCLES	PSE ALLOCATED POWER AT PD (W)	TPL <sup>(1)</sup>
1-4	0	1	12.95	HIGH
1-4	1	1	3.84	HIGH
1-4	2	1	6.49	HIGH
1-4	3	1	12.95	HIGH
2	4	2	25.5	LOW
3-4	4	2-3	25.5	LOW
3-4	5	4	40	LOW_25%
3-4	6	4	51	LOW_25%
PoE++	5,6	-	-	LOW_50%

- (1) If APD or PPD is high, TPL output becomes low with 75% duty-cycle.

During startup, the TPH, TPL and  $\overline{BT}$  outputs are enabled only once the DC-DC controller has reached steady-state, the soft-start having been completed. These 3 outputs will return to a high-impedance state in any of the following cases:

- DC-DC controller is back to soft-start mode
- DC-DC controller transitions to soft-stop mode
- DC-DC controller shuts off due to reasons including  $V_{VCC}$  falling below  $V_{CUVLO\_F}$ , or the PoE hotswap is in inrush limit while APD is low
- The device enters thermal shutdown

Note that in all these cases, as long as VDD-to-VSS voltage remains above the mark reset threshold, the internal logic state of these signals is remembered such that these outputs will be activated accordingly after the soft-start has completed. This circuit resets when the VDD-to-VSS voltage drops below the mark reset threshold. The TPH, TPL and  $\overline{BT}$  pins can be left unconnected if not used.

### 8.3.7 DC-DC Controller Features

The TPS23730 device DC-DC controller implements a typical current-mode control as shown in [Functional Block Diagram](#). Features include oscillator, overcurrent and PWM comparators, current-sense blanker, dead time control, soft-start, soft-stop and gate driver. In addition, an internal current-compensation ramp generator, frequency synchronization logic, built-in frequency dithering functionality, thermal shutdown, and start-up current source with control are provided.

The TPS23730 is optimized for isolated converters, supporting the use of PSR (flyback configuration) and optocoupler feedback (ACF and flyback).

To support PSR, the TPS23730 includes an internal error amplifier, and the voltage feedback is from the bias winding.

If optocoupler feedback is used, the error amplifier is disabled (by use of EA\_DIS input). In this case, the optocoupler output directly drives the COMP pin which serves as a current-demand control to the PWM.

In both cases, the COMP signal is directly fed to a 5:1 internal resistor divider and an offset of  $V_{ZDC}/5$  (~0.3 V) which defines a current-demand control for the pulse width modulator (PWM). A  $V_{COMP}$  below  $V_{ZDC}$  stops converter switching, while voltages above  $(V_{ZDC} + 5 \times (V_{CSMAX} + V_{SLOPE}))$  does not increase the requested peak current in the switching MOSFET.

The internal start-up current source and control logic implement a bootstrap-type startup. The startup current source charges  $C_{VCC}$  from VDD and maintain its voltage when the converter is disabled or during the soft-start period, while operational power must come from a converter (bias winding) output.

The bootstrap source provides reliable start-up from widely varying input voltages, and eliminates the continual power loss of external resistors.

The peak current limit does not have duty cycle dependency unless  $R_S$  is used as shown in Figure 8-2 to increase slope compensation. This makes it easier to design the current limit to a fixed value.

The DC-DC controller has an OTSD that can be triggered by heat sources including the VB regulator, GATE driver, bootstrap current source, and bias currents. The controller OTSD turns off VB, the switching FET, resets the soft-start generator, and forces the VCC control into an undervoltage state.

### 8.3.7.1 VCC, VB, VBG and Advanced PWM Startup

The VCC pin connects to the auxiliary bias supply for the DC-DC controller. The switching MOSFET gate driver draws current directly from the VCC pin. VB and VBG outputs are regulated down from VCC voltage, the former providing power to the internal control circuitry and external feedback optocoupler (when in use), and the latter providing power to the switching FET gate predriver circuit. A startup current source from VDD to VCC implements the converter bootstrap startup. VCC must receive power from an auxiliary source, such as an auxiliary winding on the flyback transformer, to sustain normal operation after startup.

The startup current source is turned on during the inrush phase, charging  $C_{VCC}$  and maintaining its voltage, and it is turned off only after the DC-DC soft-start cycle has been completed, which occurs when the DC-DC converter has ramped up its output voltage and  $V_{SST}$  has exceed approximately 2.1 V ( $V_{STUOF}$ ), as shown in Figure 8-1. Internal loading on VCC, VB and VBG is initially minimal while  $C_{VCC}$  charges, to allow the converter to start. Due to the high current capability of the startup source, the recommended capacitance at VCC is relatively small, typically 1  $\mu$ F in most applications.

Once  $V_{VCC}$  falls below its UVLO threshold ( $V_{CUVLO\_F}$ , approximately 6.1 V), the converter shuts off and the startup current source is turned back on, initiating a new PWM startup cycle.

If however a  $V_{VCC}$  fall (below approximately 7.1 V) is due to a light load condition causing temporary switching stop, the startup is immediately and for a short period turned back on to bring VCC voltage back up, with no converter interruption.

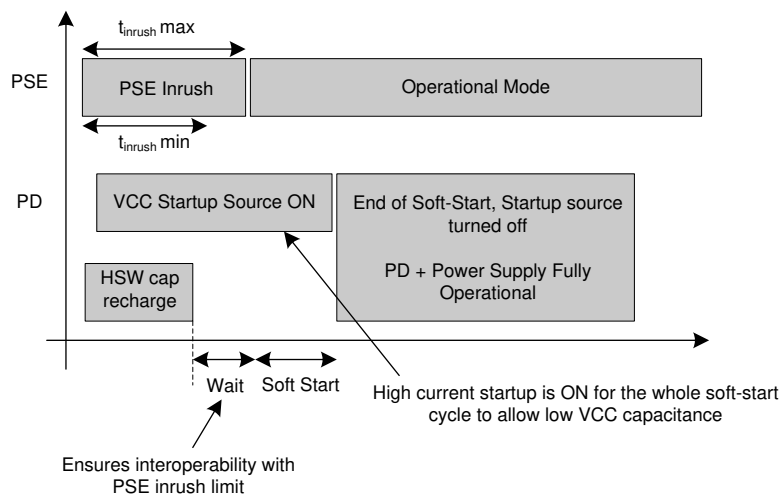

Figure 8-1. Advanced Startup

Note that the startup current source is also turned on while in soft-stop mode.

### 8.3.7.2 CS, Current Slope Compensation and Blanking

The current-sense input for the DC-DC converter should be connected to the high side of the current-sense resistor of the switching MOSFET. This voltage drives the current limit comparator and the PWM comparator (see Block Diagram of DC-DC controller). A leading-edge blanking circuit prevents MOSFET turn-on transients from falsely triggering either of these comparators. During the off time, and also during the blanking time that immediately follows, the CS pin is pulled to AGND through an internal pulldown resistor.

The current limit comparator terminates the on-time portion of the switching cycle as soon as  $V_{CS}$  exceeds approximately 250 mV ( $V_{CSMAX}$ ) and the leading edge blanking interval has expired. If the converter is not in current limit, then either the PWM comparator or the maximum duty cycle limiting ( $D_{MAX}$ ) circuit terminates the on time.

Current-mode control requires addition of a compensation ramp to the sensed inductive (transformer or inductor) current for stability at duty cycles near and over 50%. The TPS23730 provides an internal slope compensation circuit which generates a current that imposes a voltage ramp at the positive input of the PWM comparator to suppress sub-harmonic oscillations. This current flows out of the CS pin. If desired, the magnitude of the slope compensation can be increased by the addition of an external resistor  $R_S$  (see Figure 8-2) in series with the CS pin. It works with ramp current ( $I_{PK} = I_{SL-EX}$ , approximately 20  $\mu A$ ) that flows out of the CS pin when the MOSFET is on. The  $I_{PK}$  specification does not include the approximately 2- $\mu A$  fixed current that flows out of the CS pin.

The TPS23730 has a maximum duty cycle limit of 78%, permitting the design of wide input-range converters with a lower voltage stress on the output rectifiers. While the maximum duty cycle is 78%, converters may be designed that run at duty cycles well below this for a narrower, 36-V to 57-V range.

Most current-mode control papers and application notes define the slope compensation values in terms of  $V_{PP}/T_S$  (peak ramp voltage / switching period); however, [Electrical Characteristics: DC-DC Controller Section](#) specifies the slope peak ( $V_{SLOPE}$ ) based on the maximum duty cycle. Assuming that the desired slope,  $V_{SLOPE-D}$  (in mV/period), is based on the full period, compute  $R_S$  per Equation 1 where  $V_{SLOPE}$ ,  $D_{MAX}$ , and  $I_{SL-EX}$  are from [Electrical Characteristics: DC-DC Controller Section](#) with voltages in mV, current in  $\mu A$ , and the duty cycle is unitless (for example,  $D_{MAX} = 0.78$ ).

$$R_S(\Omega) = \frac{\left[ V_{SLOPE-D}(\text{mV}) - \left( V_{SLOPE}(\text{mV}) / D_{MAX} \right) \right]}{I_{SL-EX}(\mu A)} \times 1000 \quad (1)$$

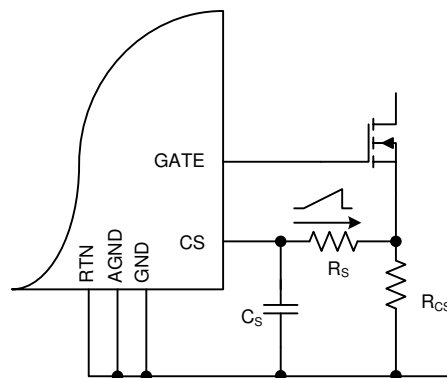

**Figure 8-2. Additional Slope Compensation**

The TPS23730 blanker timing is precise enough that the traditional R-C filters on CS can be eliminated. This avoids current-sense waveform distortion, which tends to get worse at light output loads. There may be some situations or designers that prefer an R-C approach, for example if the presence of  $R_S$  causes increased noise, due to adjacent noisy signals, to appear at CS pin. The TPS23730 provides a pulldown on CS (~400  $\Omega$ ) during



the GATE OFF-time to improve sensing when an R-C filter must be used, by reducing cycle-to-cycle carry-over voltage on  $C_S$ .

Routing between the current-sense resistor and the CS pin should be short to minimize cross-talk from noisy traces such as the gate drive signal and the CP signal.

### 8.3.7.3 COMP, FB, EA\_DIS, CP, PSRS and Opto-less Feedback

The TPS23730 DC-DC controller implements current-mode control as shown in [Functional Block Diagram](#), using internal (via pins FB input and COMP output, with EA\_DIS pulled low) or external (via COMP input, with EA\_DIS open) voltage control loop error amplifier to define the input reference voltage of the current mode control comparator which determines the switching MOSFET peak current.

$V_{COMP}$  below  $V_{ZDC}$  causes the converter to stop switching. The maximum (peak) current is requested at approximately  $(V_{ZDC} + 5 \times (V_{CSMAX} + V_{SLOPE}))$ . The AC gain from COMP to the PWM comparator is typically 0.2.

In flyback applications and with the internal error amplifier enabled, the TPS23730 DC-DC controller can operate with feedback from an auxiliary winding of the flyback power transformer to achieve primary side regulation (PSR), eliminating the need for external shunt regulator and optocoupler. One noteworthy characteristic of this PSR is that it operates with continuous (DC) feedback, enabling better optimization of the power supply, and resulting in significantly lower noise sensitivity.

When combined with secondary-side synchronous rectification (with PSRS open), the opto-less operation of the TPS23730 is achieved with a unique approach which basically consists in actively cancelling (through the use of CP output) the leading-edge voltage overshoot (causing the feedback capacitor to peak-charge) generated by the transformer winding. When combined with a correctly designed power transformer, less than  $\pm 1.5\%$  load regulation (typical) over the full output current range becomes achievable in applications making use of secondary-side synchronous rectifiers. Operation is in continuous conduction mode (CCM), also enabling multi-output architectures.

Opto-less operation of the TPS23730 also applies (with PSRS pulled low) to single-output flyback converter applications where a secondary-side diode rectifier is used. In typical 12-V output application and when combined with a correctly designed power transformer,  $\sim \pm 3\%$  load regulation over a wide (< 5% to 100%) output current range can be achieved.

In applications where the internal error amplifier is disabled, the COMP pin receives the control voltage typically from a TL431 or TLV431 shunt regulator driving an optocoupler, using VB pin as a pull up source, although other configurations are possible.

### 8.3.7.4 FRS Frequency Setting and Synchronization

The FRS pin programs the (free-running) oscillator frequency, and may also be used to synchronize the TPS23730 converter to a higher frequency. The internal oscillator sets the maximum duty cycle and controls the current-compensation ramp circuit, making the ramp height independent of frequency.  $R_{FRS}$  must be selected per [Equation 2](#).

$$R_{FRS} \text{ (k}\Omega\text{)} = \frac{15000}{f_{SW} \text{ (kHz)}} \quad (2)$$

The TPS23730 may be synchronized to an external clock to eliminate beat frequencies from a sampled system, or to place emission spectrum away from an RF input frequency. Synchronization may be accomplished by applying a short pulse ( $> 25$  ns) of magnitude  $V_{SYNC}$  to FRS as shown in [Figure 8-3](#).  $R_{FRS}$  must be chosen so that the maximum free-running frequency is just below the desired synchronization frequency. The synchronization pulse terminates the potential ON-time period, and the OFF-time period does not begin until the pulse terminates. A short pulse is preferred to avoid reducing the potential ON-time.

Figure 8-3 shows examples of nonisolated and transformer-coupled synchronization circuits. RT reduces noise susceptibility for the isolation transformer implementation. The FRS node must be protected from noise because it is high impedance.

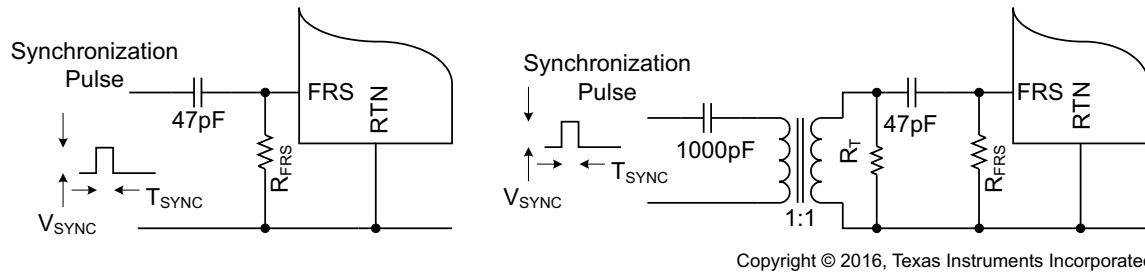

Copyright © 2016, Texas Instruments Incorporated

**Figure 8-3. Synchronization****8.3.7.5 DTHR and Frequency Dithering for Spread Spectrum Applications**

The international standard CISPR 22 (and adopted versions) is often used as a requirement for conducted emissions. Ethernet cables are covered as a telecommunication port under section 5.2 for conducted emissions. Meeting EMI requirements is often a challenge, with the lower limits of Class B being especially hard. Circuit board layout, filtering, and snubbing various nodes in the power circuit are the first layer of control techniques. A more detailed discussion of EMI control is presented in *Practical Guidelines to Designing an EMI Compliant PoE Powered Device With Isolated Flyback*, [SLUA469](#). Additionally, IEEE 802.3at sections 33.3 and 33.4 and IEEE 802.3bt sections 145.3 and 145.4 have requirements for noise injected onto the Ethernet cable based on compatibility with data transmission.

A technique referred to as frequency dithering can also be used to provide additional EMI measurement reduction. The switching frequency is modulated to spread the narrowband individual harmonics across a wider bandwidth, thus lowering peak measurements.

Fully programmable frequency dithering is a built-in feature of the TPS23730. The oscillator frequency can be dithered by connecting a capacitor from DTHR to RTN and a resistor from DTHR to FRS. An external capacitor,  $C_{DTR}$  (Figure 9-1), is selected to define the modulation frequency  $f_m$ . This capacitor is being continuously charged and discharged between slightly less than 0.5 V and slightly above 1.5 V by a current source/sink equivalent to  $\sim 3x$  the current through FRS pin.  $C_{DTR}$  value is defined according to:

$$C_{DTR} = \frac{3/R_{FRS} (\Omega)}{2.052 \times f_m (\text{Hz})} \quad (3)$$

$f_m$  should always be higher than 9 kHz, which is the resolution bandwidth applied during conducted emission measurement. Typically,  $f_m$  should be set to around 11 kHz to account for component variations.

The resistor  $R_{DTR}$  is used to determine  $\Delta f$ , which is the amount of dithering, and its value is determined according to:

$$R_{DTR} (\Omega) = \frac{0.513 \times R_{FRS} (\Omega)}{\%DTHR} \quad (4)$$

For example, a 13.2% dithering with a nominal switching frequency of 250 kHz results in frequency variation of  $\pm 33$  kHz.

**8.3.7.6 SST and Soft-Start of the Switcher**

Converters require a soft-start to prevent output overshoot on startup. In PoE applications, the PD also needs soft-start to limit its input current at turn on below the limit allocated by the power source equipment (PSE).

For flyback applications using primary-side control, the TPS23730 provides closed loop controlled soft-start, which applies a slowly rising ramp voltage to a second control input of the error amplifier. The lower of the reference input and soft-start ramp controls the error amplifier, allowing the output voltage to rise in a smooth monotonic fashion.

In all other applications where secondary-side regulation is used, the TPS23730 provides a current-loop soft-start, which controls the switching MOSFET peak current by applying a slowly rising ramp voltage to a

second PWM control input. The lower of COMP-derived current demand and soft-start ramp controls the PWM comparator. Note that in this case there is usually a (slower) secondary-side soft-start implemented with the typical TL431 or TLV431 error amplifier to complement the action of the primary-side soft-start.

The soft-start period of the TPS23730 is adjustable with a capacitor between SST and RTN. During soft-start,  $C_{SST}$  (Figure 9-1) is being charged from less than 0.2 V to 2.45 V by a  $\sim 10\text{-}\mu\text{A}$  current source. Once  $V_{SST}$  has exceeded approximately 2.1 V ( $V_{STUOF}$ ), the VCC startup is also turned off.

The actual control range of the primary-side closed-loop soft-start capacitor voltage is between 0.25 V and 2 V nominally. Therefore, the soft-start capacitor value must be based on this control range and the required soft-start period ( $t_{SS}$ ) according to:

$$C_{SS}(\text{nF}) = \frac{I_{SSC}(\mu\text{A}) \times t_{SS}(\text{ms})}{(2 - 0.25)} \quad (5)$$

The actual control range of the current-loop soft-start capacitor voltage is between 0.6 V and 1.2 V nominally. Therefore, the soft-start capacitor value must be based on this control range and the required soft-start period ( $t_{SS}$ ) according to:

$$C_{SS}(\text{nF}) = \frac{I_{SSC}(\mu\text{A}) \times t_{SS}(\text{ms})}{(1.2 - 0.6)} \quad (6)$$

Note that the VCC startup turns off only when 2.1 V is reached, allowing additional time for the secondary-side soft-start to complete. For more details regarding the secondary-side soft start, refer to [Application Information](#).

### 8.3.7.7 SST, I\_STP, LINEUV and Soft-Stop of the Switcher

The soft-stop feature is provided by the TPS23730 to minimize stress on switching power components caused by power shutdown, allowing FET BOM cost reduction, in particular for ACF applications. Soft-stop action consists in discharging in a controlled way the output capacitor of the converter, sending back the energy to the input bulk capacitor.

Once the LINEUV input detects that the input power source has been removed (while APD is also low), the SST capacitor is discharged with a constant current, ramping down the switching MOSFET peak current. The SST discharge current ( $I_{SSD\_SP}$ ) is defined with  $R_{I\_STP}$  according to:

$$I_{SSD\_SP}(\mu\text{A}) = \frac{1000}{R_{I\_STP}(\text{k}\Omega)} \quad (7)$$

To accelerate the impact of the soft-stop, the internal peak current limit threshold is also immediately stepped down to approximately 50 mV at beginning of soft-stop.

### 8.3.8 Switching FET Driver - GATE, GTA2, DT

GATE is the gate drive outputs for the DC-DC converter's main switching MOSFET, while GAT2 is its second gate drive.

GATE's phase turns the main switch on when it transitions high, and off when it transitions low. It is also held low when the converter is disabled.

GAT2's phase turns the second switch off when it transitions high, and on when it transitions low. GAT2 is also held low when the converter is disabled. This output can drive active-clamp PMOS devices, and driven flyback synchronous rectifiers. Connecting DT to VB also disables GAT2 in a high-impedance condition.

DT input is used to set the delay between GATE and GAT2 to prevent overlap of MOSFET on times as shown in Figure 7-1. Both MOSFETs should be off between GAT2 going high to GATE going high, and GATE going low to GAT2 going low. The maximum GATE ON time is reduced by the programmed dead-time period. The dead time

period is specified with 1 nF of capacitance on GATE and with 0.5-nF capacitance on GAT2. Different loading on these pins changes the effective dead time. A resistor connected from DT to AGND sets the delay between GATE and GAT2 following TBD figure. Note that even in situations like VCC UVLO or return to inrush phase, the programmed dead time is maintained until the switching stops completely.

### 8.3.9 EMPS and Automatic MPS

To maintain PSE power in situation of very low  $I_{RTN}$  condition, the TPS23730 generates a pulsed current through VSS pin with an amplitude adjusted such that its net current reaches a level high enough to maintain power.

The pulsed current amplitude ( $I_{MPSL}$ ,  $I_{MPSH}$ ) and duration ( $t_{MPSL}$ ,  $t_{MPSH}$ ) are automatically selected according to PSE Type (1-2, 3-4), to maintain PSE power while minimizing power consumption. Auto-stretch feature is also used to cancel the impact of system conditions (bulk capacitance and PoE cable impedance) on the effective pulsed current duration. See Figure 8-4, where the illustrated pulsed current is coming out of the VSS pin, while  $I_{LOAD}$  is the DC current going into the RTN pin.

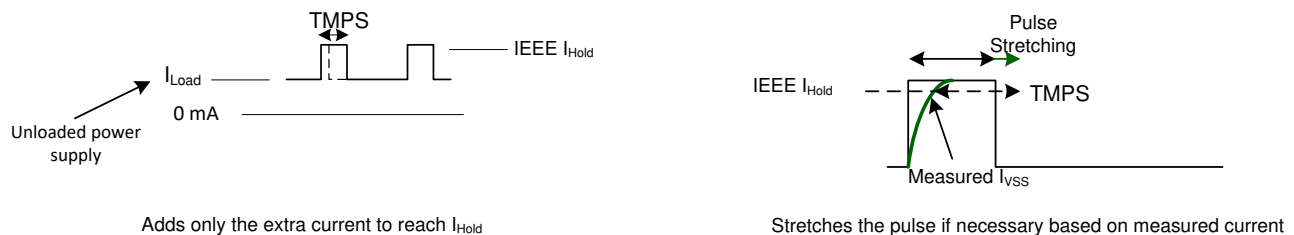

Figure 8-4. Auto MPS

Note that prior to entering the MPS mode, a light load condition is detected on RTN pin with a deglitch time period of approximately 5 ms.

### 8.3.10 VDD Supply Voltage

VDD connects to the positive side of the input supply. It provides operating power to the PD controller, allows monitoring of the input line voltage and serves as the source of DC-DC converter startup current. If  $V_{VDD}$  falls below its UVLO threshold and goes back above it, or if a thermal shutdown resumes even if  $V_{VDD}$  remains above its UVLO threshold, the TPS23730 returns to inrush phase.

### 8.3.11 RTN, AGND, GND

RTN is internally connected to the drain of the PoE hotswap MOSFET, while AGND is the quiet analog reference for the DC-DC controller return. GND is the power ground used by the flyback power FET gate driver and CP output, and should be tied to AGND and RTN plane. The AGND / GND / RTN net should be treated as a local reference plane (ground plane) for the DC-DC control and converter primary. The PAD\_G exposed thermal pad is internally connected to RTN pin.

### 8.3.12 VSS

VSS is the PoE input-power return side. It is the reference for the PoE interface circuits, and has a current-limited hotswap switch that connects it to RTN. VSS is clamped to a diode drop above RTN by the hotswap switch. The PAD\_S exposed thermal pad is internally connected to VSS pin. This pad must be connected to VSS pin to ensure proper operation.

### 8.3.13 Exposed Thermal pads - PAD\_G and PAD\_S

PAD\_G should be tied to a large RTN copper area on the PCB to provide a low resistance thermal path to the circuit board.

PAD\_S should be tied to a large VSS copper area on the PCB to provide a low resistance thermal path to the circuit board. TI recommends maintaining a clearance of 0.025" between VSS and high-voltage signals such as VDD.

## 8.4 Device Functional Modes

### 8.4.1 PoE Overview

The following text is intended as an aid in understanding the operation of the TPS23730, but it is not a substitute for the actual IEEE 802.3bt or 802.3at standards. The IEEE 802.3bt standard is an update to IEEE 802.3-2018, adding Clause 145 (PoE), including power delivery using all four pairs, high-power options, additional features to reduce standby power consumption and enhanced classification.

Generally speaking, a device compliant to IEEE 802.3-2012 is referred to as a Type 1 (Class 0-3) or 2 (Class 4) device, and devices with higher power and enhanced classification is referred to as Type 3 (Class 5, 6) or 4 (Class 7, 8) devices. Type 3 devices will also include Class 0-4 devices that are 4-pair capable. Standards change and must always be referenced when making design decisions.

The IEEE 802.3at and 802.3bt standards define a method of safely powering a PD (powered device) over a cable by power sourcing equipment (PSE), and then removing power if a PD is disconnected. The process proceeds through an idle state and three operational states of detection, classification, and operation. There is also a fourth operational state used by Type 3 and 4 PSEs, called "connection check", to determine if the PD has same (single interface) or independent (dual interface or commonly referred to "dual-signature" in the IEEE802.3bt standard) classification signature on each pairset. The PSE leaves the cable unpowered (idle state) while it periodically looks to see if something has been plugged in; this is referred to as detection. The low power levels used during detection and connection check are unlikely to damage devices not designed for PoE. If a valid PD signature is present, the PSE may inquire how much power the PD requires; this is referred to as classification. The PSE may then power the PD if it has adequate capacity.

Type 3 or Type 4 PSEs are required to do an enhanced hardware classification of Type 3 or 4 respectively. Type 2 PSEs are required to do Type 1 hardware classification plus a data-layer classification, or an enhanced Type 2 hardware classification. Type 1 PSEs are not required to do hardware or data link layer (DLL) classification. A Type 3 or Type 4 PD must do respectively Type 3 or Type 4 hardware classification as well as DLL classification. A Type 2 PD must do Type 2 hardware classification as well as DLL classification. The PD may return the default, 13-W current-encoded class, or one of four other choices if Type 2, one of six other choices if Type 3, and one of eight other choices if Type 4. DLL classification occurs after power-on and the Ethernet data link has been established

Once started, the PD must present the maintain power signature (MPS) to assure the PSE that it is still present. The PSE monitors its output for a valid MPS, and turns the port off if it loses the MPS. Loss of the MPS returns the PSE to the idle state. Figure 8-5 shows the operational states as a function of PD input voltage.

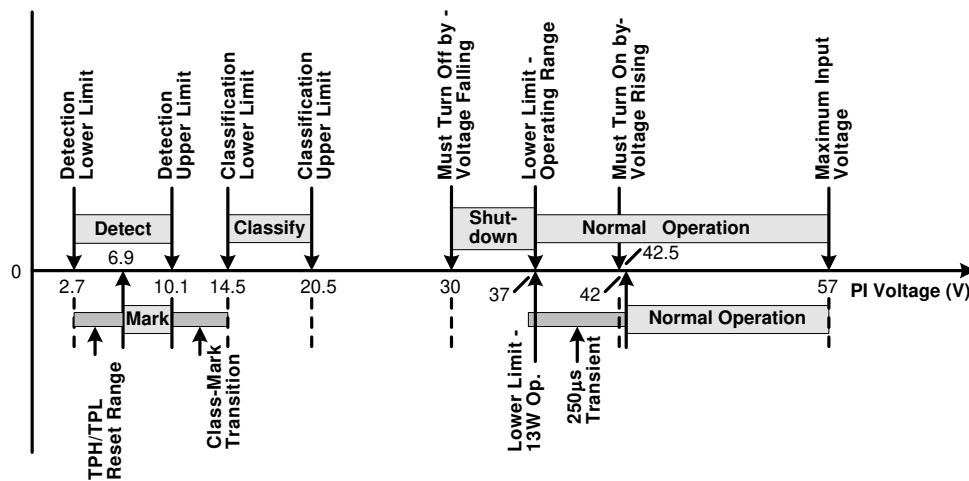

Figure 8-5. Operational States

The PD input, typically an RJ-45 eight-lead connector, is referred to as the power interface (PI). PD input requirements differ from PSE output requirements to account for voltage drops and operating margin. The

standard allots the maximum loss to the cable regardless of the actual installation to simplify implementation. IEEE 802.3-2008 was designed to run over infrastructure including ISO/IEC 11801 class C (CAT3 per TIA/EIA-568) that may have had AWG 26 conductors. IEEE 802.3at Type 2 and IEEE 802.3bt Type 3 cabling power loss allotments and voltage drops have been adjusted for 12.5-Ω power loops per ISO/IEC11801 class D (CAT5 or higher per TIA/EIA-568, typically AWG 24 conductors). [Table 8-4](#) shows key operational limits broken out for the two revisions of the standard.

**Table 8-4. Comparison of Operational Limits**

STANDARD	POWER LOOP RESISTANCE (MAX)	PSE OUTPUT POWER (MIN)	PSE STATIC OUTPUT VOLTAGE (MIN)	PD INPUT POWER (MAX)	STATIC PD INPUT VOLTAGE	
					POWER ≤ 13 W	POWER > 13 W
IEEE802.3-2012 802.3at (Type 1)	20 Ω	15.4 W	44 V	13 W	37 V – 57 V	N/A
802.3bt (Type 3)	12.5 Ω		50 V			
802.3at (Type 2) 802.3bt (Type 3)	12.5 Ω	30 W	50 V	25.5 W	37 V – 57 V	42.5 V – 57 V
802.3bt (Type 3)	6.25 Ω (4-pair)	60 W	50 V	51 W	N/A	42.5 V - 57 V
802.3bt (Type 4)	6.25 Ω (4-pair)	90 W	52 V	71.3 W	N/A	41.2 V - 57 V

The PSE can apply voltage either between the RX and TX pairs (pins 1–2 and 3–6 for 10baseT or 100baseT), or between the two spare pairs (4–5 and 7–8). Power application to the same pin combinations in 1000/2.5G/5G/10GbaseT systems is recognized in IEEE 802.3bt. 1000/2.5G/5G/10GbaseT systems can handle data on all pairs, eliminating the spare pair terminology. Type 1 and 2 PSEs are allowed to apply voltage to only one set of pairs at a time, while Type 3 and 4 PSEs may apply power to one or both sets of pairs at a time. The PD uses input diode or active bridges to accept power from any of the possible PSE configurations. The voltage drops associated with the input bridges create a difference between the standard limits at the PI and the TPS23730 specifications.

A compliant Type 2, 3 or 4 PD has power management requirements not present with a Type 1 PD. These requirements include the following:

1. Must interpret respectively Type 2, 3 or 4 hardware classification.
2. Must present hardware Class 4 during the first two classification events, applicable to Type 2 and 4 PDs, as well as to Type 3 PD with Class level 4 or higher.
3. If Type 3 Class 5-6 or Type 4 single interface PD, it must present hardware Class in the range of 0 to 3 during the third and any subsequent classification events.
4. Must implement DLL negotiation.
5. Must draw less than 400 mA from 50 ms until 80 ms after the PSE applies operation voltage (power up), if Type 2 or 3, single interface PD. This covers the PSE inrush period, which is 75 ms maximum.
6. Must draw less than 800 mA total and 600 mA per pairset from 50 ms until 80 ms after the PSE applies operation voltage (power up), if Type 4 (Class 7-8) single interface PD.
7. Must not draw more than 60 mA and 5 mA any time the input voltage falls below respectively 30 V and 10 V.
8. Must not draw more than 13 W if it has not received at least a Type 2 hardware classification or received permission through DLL.
9. Must not draw more than 25.5 W if it has not received at least 4 classification events or received permission through DLL.
10. Must not draw more than 51 W if it has not received at least 5 classification events or received permission through DLL.
11. Must meet various operating and transient templates.
12. Optionally monitor for the presence or absence of an adapter.

As a result of these requirements, the PD must be able to dynamically control its loading, and monitor TPL and TPH for changes. TPH and TPL can also be used in cases where the design needs to know specifically if an adapter is plugged in and operational.

#### 8.4.2 Threshold Voltages

The TPS23730 has a number of internal comparators with hysteresis for stable switching between the various states as shown in [Figure 8-5](#). [Figure 8-6](#) relates the parameters in [Electrical Characteristics PoE](#) to the PoE

states. The mode labeled idle between classification and operation implies that the DEN, CLSA, CLSB, and RTN pins are all high impedance. The state labeled Mark, which is drawn in dashed lines, is part of the Type 2-3-4 hardware class state machine.

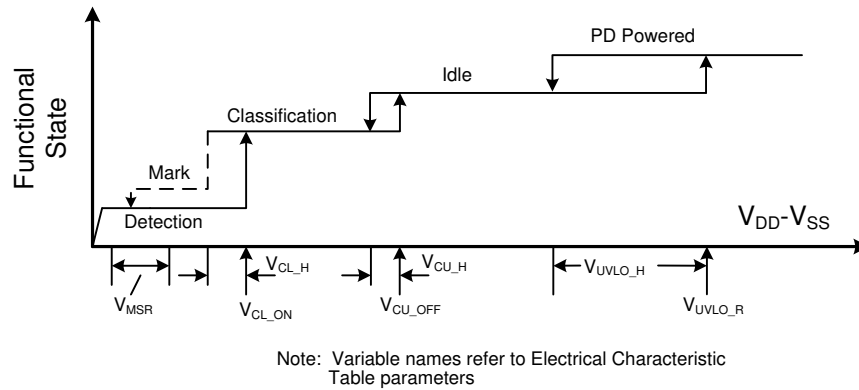
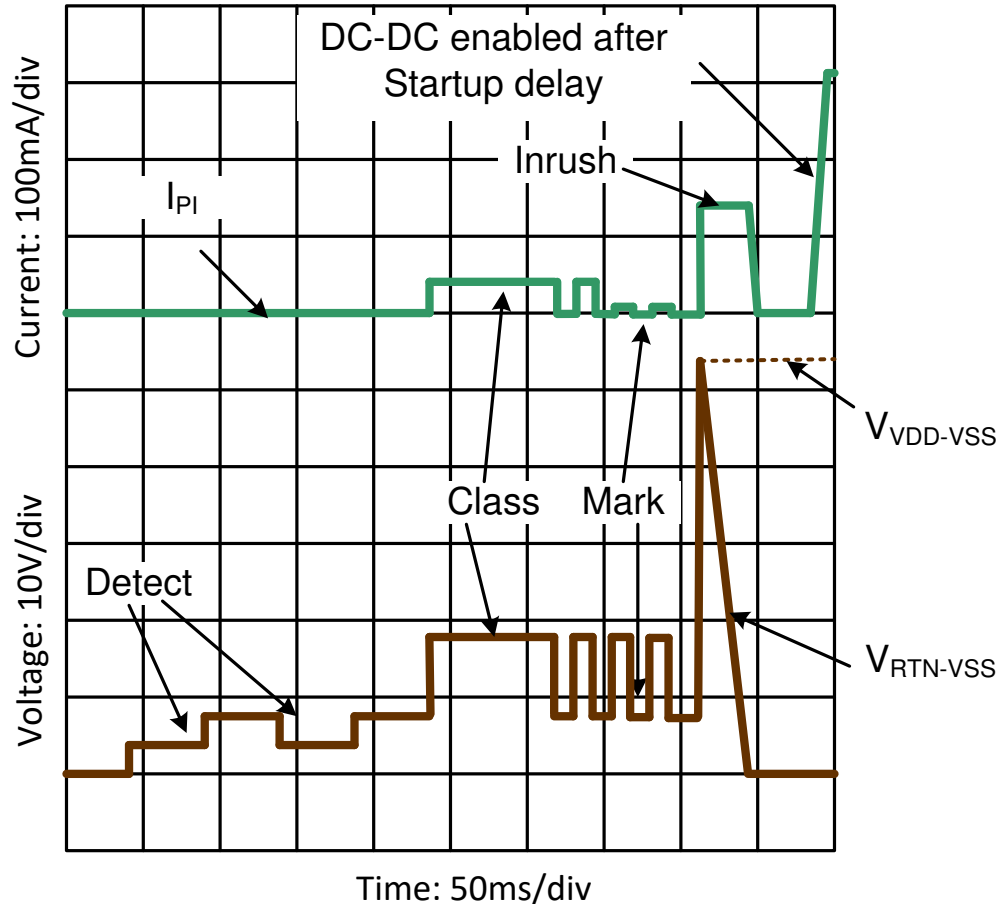

**Figure 8-6. Threshold Voltages**

### 8.4.3 PoE Start-Up Sequence

The waveforms of Figure 8-7 demonstrate detection, classification, and start-up from a Type 3 or 4 PSE with Class 6 hardware classification. The key waveforms shown are  $V_{VDD-VSS}$ ,  $V_{RTN-VSS}$ , and  $I_{PI}$ . IEEE802.3bt and IEEE 802.3at require a minimum of two detection levels; however, four levels are shown in this example. Four levels guard against misdetection of a device when plugged in during the detection sequence.

IEEE 802.3bt also requires a PSE allocating Class 6 level of power to generate four class and mark cycles, and startup from the fourth mark event. As shown below, the required minimum duration of the first class event has been extended for Type 3 and 4 PSEs.  $V_{RTN}$  to  $V_{SS}$  falls as the TPS23730 charges  $C_{BULK}$  following application of full voltage. In Figure 8-9, the converter soft-start is also delayed until the end of inrush period.



**Figure 8-7. PoE Start-Up Sequence**

#### 8.4.4 Detection

The TPS23730 is in detection mode whenever  $V_{VDD-V_{SS}}$  is below the lower classification threshold. When the input voltage rises above  $V_{CL\_ON}$ , the DEN pin goes to an open-drain condition to conserve power. While in detection, RTN is high impedance, almost all the internal circuits are disabled, and the DEN pin is pulled to  $V_{SS}$ . An  $R_{DEN}$  of 25.5 k $\Omega$  (1%), presents the correct signature. It may be a small, low-power resistor because it only sees a stress of about 5 mW. A valid PD detection signature is an incremental resistance between 23.75 k $\Omega$  and 26.25 k $\Omega$  at the PI.

The detection resistance seen by the PSE at the PI is the result of the input bridge resistance in series with the parallel combination of  $R_{DEN}$  and the TPS23730 bias loading. The incremental resistance of the input diode bridge may be hundreds of ohms at the very low currents drawn when 2.7 V is applied to the PI. The input bridge resistance is partially cancelled by the effective resistance of the TPS23730 during detection.

#### 8.4.5 Hardware Classification

Hardware classification allows a PSE to determine a PD's power requirements before powering, and helps with power management once power is applied. Type 2, 3, and 4 hardware classification permits high power PDs to determine whether the PSE can support its high-power operation. The number of class cycles generated by the PSE prior to turn on indicates to the PD if it allots the power requested or if the allocated power is less than requested, in which case there is power demotion.

A Type 2 PD always presents Class 4 in hardware to indicate that it is a 25.5W device. A Class 5 or 6 Type 3 PD presents Class 4 in hardware during the first two class events and it presents Class 0 or 1, respectively, for all subsequent class events. A Class 7 or 8 Type 4 PD presents Class 4 in hardware during the first two class events and it presents Class 2 or 3, respectively, for all subsequent class events. A Type 1 PSE will treat



a Class 4 to 8 device like a Class 0 device, allotting 13 W if it chooses to power the PD. A Type 2 PSE will treat a Class 5 to 8 device like a Class 4 device, allotting 25.5W if it chooses to power the PD. A Class 4 PD that receives a 2-event class, a Class 5 or 6 PD that receives a 4-event class, or a Class 7 or 8 PD that receives a 5-event class, understands that the PSE has agreed to allocate the PD requested power. In the case where there is power demotion, the PD may choose to not start, or to start while not drawing more power than initially allocated, and request more power through the DLL after startup. The standard requires a Type 2, 3 or 4 PD to indicate that it is underpowered if this occurs. Startup of a high-power PD at lower power than requested implicitly requires some form of powering down sections of the application circuits.

The maximum power entries in [Table 8-1](#) determine the class the PD must advertise. The PSE may disconnect a PD if it draws more than its stated class power, which may be the hardware class or a DLL-derived power level. The standard permits the PD to draw limited current peaks that increase the instantaneous power above the [Table 8-1](#) limit; however, the average power requirement always applies.

The TPS23730 implements one- to four-event classification.  $R_{CLSA}$  and  $R_{CLSB}$  resistor values define the class of the PD. DLL communication is implemented by the Ethernet communication system in the PD and is not implemented by the TPS23730.

The TPS23730 disables classification above  $V_{CU\_OFF}$  to avoid excessive power dissipation. CLSA/B voltage is turned off during PD thermal limiting or when APD or DEN is active. The CLSA and CLSB outputs are inherently current-limited, but should not be shorted to  $V_{SS}$  for long periods of time.

[Figure 8-8](#) shows how classification works for the TPS23730. Transition from state-to-state occurs when comparator thresholds are crossed (see [Figure 8-5](#) and [Figure 8-6](#)). These comparators have hysteresis, which adds inherent memory to the machine. Operation begins at idle (unpowered by PSE) and proceeds with increasing voltage from left to right. A 2- to 4-event classification follows the (heavy lined) path towards the bottom, ending up with a latched TPL/TPH decode along the lower branch that is highlighted. Once the valid path to the PSE detection is broken, the input voltage must transition below the mark reset threshold to start anew.

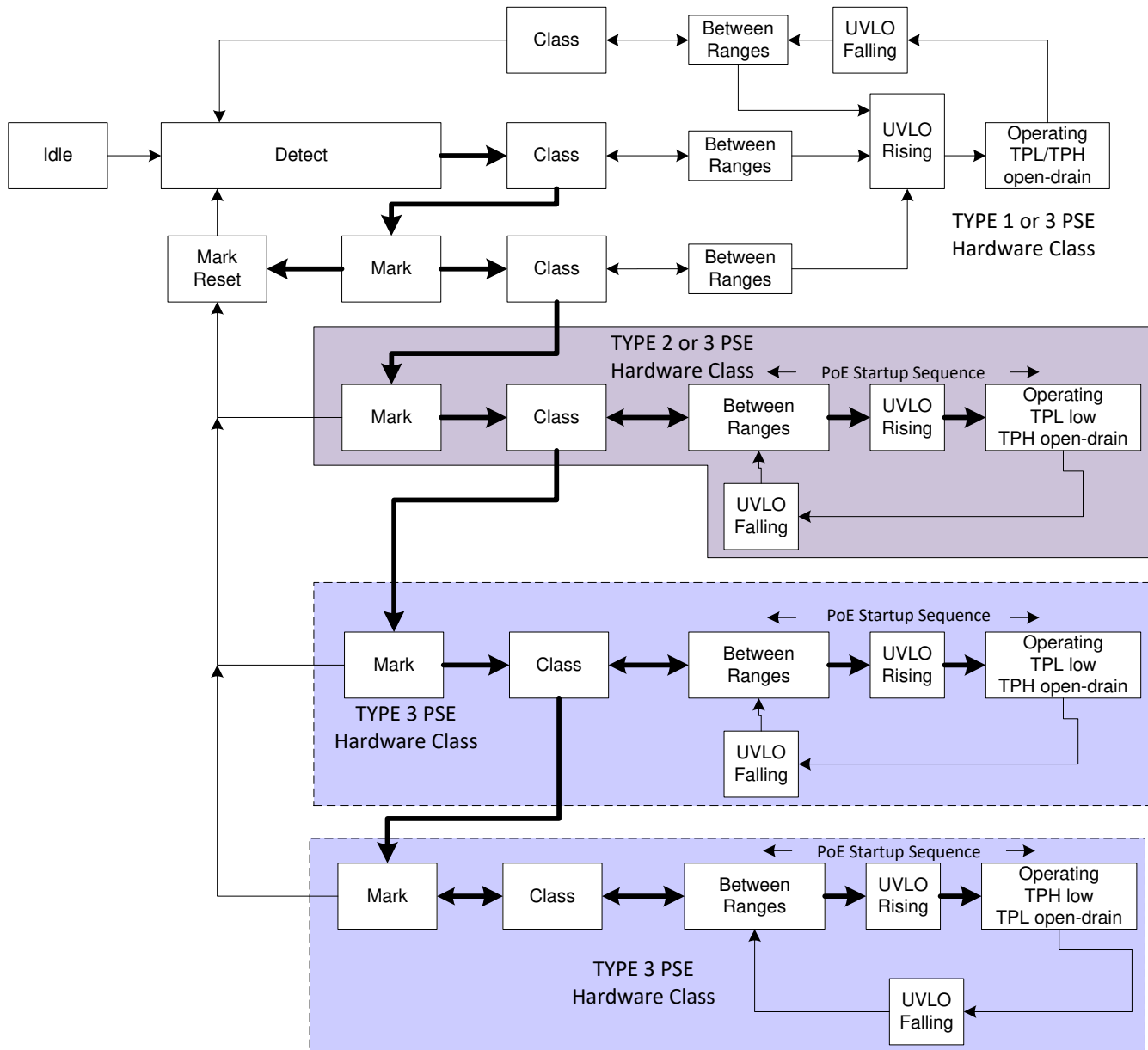

**Figure 8-8. Up to Four-Event Class Internal States**

### 8.4.6 Maintain Power Signature (MPS)

The MPS is an electrical signature presented by the PD to assure the PSE that it is still present after operating voltage is applied. For a Type 1 or Type 2 PD, a valid MPS consists of a minimum dc current of 10 mA, or a 10-mA pulsed current for at least 75 ms every 325 ms, and an AC impedance lower than 26.3 kΩ in parallel with 0.05 μF. Only Type 1 and Type 2 PSEs monitor the AC MPS. A Type 1 or Type 2 PSE that monitors only the AC MPS may remove power from the PD.

To enable applications with stringent standby requirements, IEEE802.3bt introduced a significant change regarding the minimum pulsed current duration to assure the PSE will maintain power. This applies to all Type 3 and Type 4 PSEs, and the pulse duration is ~10% of what is required for Type 1 and 2 PSEs. The MPS current amplitude requirement for Class 5-8 PDs have also increased to 16 mA at the PSE end of the ethernet cable.

If the current through the RTN-to-VSS path is very low, the TPS23730 automatically generates the MPS pulsed current through the VSS pin, with an amplitude adjusted such that its net current reaches a level high enough to maintain PSE power. The TPS23730 is also able to determine if the PSE is of Type 1-2 or

Type 3-4, automatically adjusting the pulsed current amplitude, duration and duty-cycle, while minimizing power consumption. Note that the IEEE802.3bt requirement for the PD is applicable at the PSE end of the cable. That means that depending the cable length and other parameters including the bulk capacitance, a longer pulse duration may be required to ensure a valid MPS. For that purpose, the TPS23730 provides auto-stretch capability which is used to cancel the impact of such system conditions on the effective pulsed current duration. See [Figure 8-4](#).

When APD is pulled high or when DEN is pulled to VSS (forcing the hotswap switch off), the DC MPS will not be met. A PSE that monitors the DC MPS will remove power from the PD when this occurs.

#### 8.4.7 Advanced Start-Up and Converter Operation

The internal PoE undervoltage lockout (UVLO) circuit holds the hotswap switch off before the PSE provides full voltage to the PD. This prevents the converter circuits from loading the PoE input during detection and classification. The converter circuits discharges  $C_{BULK}$ ,  $C_{VCC}$ ,  $C_{VB}$  and  $C_{VBG}$  while the PD is unpowered. Thus  $V_{VDD-RTN}$  will be a small voltage until just after full voltage is applied to the PD, as seen in [Figure 8-7](#).

The PSE drives the PI voltage to the operating range once it has decided to power up the PD. When  $V_{VDD}$  rises above the UVLO turnon threshold ( $V_{UVLO-R}$ , approximately 37.6 V) with RTN high, the TPS23730 enables the hotswap MOSFET with an approximately 140-mA (inrush) current limit. See the waveforms of [Figure 8-9](#) for an example. Converter switching is disabled while  $C_{BULK}$  charges and  $V_{RTN}$  falls from  $V_{VDD}$  to nearly  $V_{VSS}$ ; however, the converter start-up circuit is allowed to charge  $C_{VCC}$  (the VB regulator also powers the internal converter circuits as  $V_{VCC}$  rises). Once the inrush current falls about 10% below the inrush current limit, the PD current limit switches to the operational level (approximately 1.85 A). Additionally, once the inrush period duration has also exceeded approximately 84 ms (end of inrush phase), the converter switching is allowed to start, once  $V_{VCC}$  also goes above its UVLO (approximately 8.25 V).

Continuing the start-up sequence shown in [Figure 8-9](#), once  $V_{VCC}$  goes above its UVLO, the soft-start (SST) capacitor is first discharged with controlled current ( $I_{SSD}$ ) below nominally 0.2 V ( $V_{SFST}$ ) if the discharge was not already completed, then it is gradually recharged until it reaches  $\sim 0.25$  V ( $V_{SSOFS}$  in closed-loop mode) at which point the converter switching is enabled, following the closed loop controlled soft-start sequence. Note that the startup current source capability is such that it can fully maintain  $V_{VCC}$  during the converter soft-start without requiring any significant  $C_{VCC}$  capacitance, in 48 V input applications. At the end of the soft-start period, more specifically when SST voltage has exceeded  $\sim 2$  V ( $V_{STUOF}$ ), the startup current source is turned off.  $V_{VCC}$  falls as it powers the internal circuits including the switching MOSFET gate. If the converter control-bias output rises to support  $V_{VCC}$  before it falls to  $V_{CUVLO\_F}$  ( $\sim 6.1$  V), a successful start-up occurs. [Figure 8-9](#) shows a small droop in  $V_{VCC}$  while the output voltage rises smoothly and a successful start-up occurs.

[Figure 8-10](#) also illustrates similar scenario if optocoupler feedback is used instead of PSR. In this case, the converter switching is enabled when  $V_{SST}$  exceeds approximately 0.6 V ( $V_{SSOFS}$  in peak current mode).

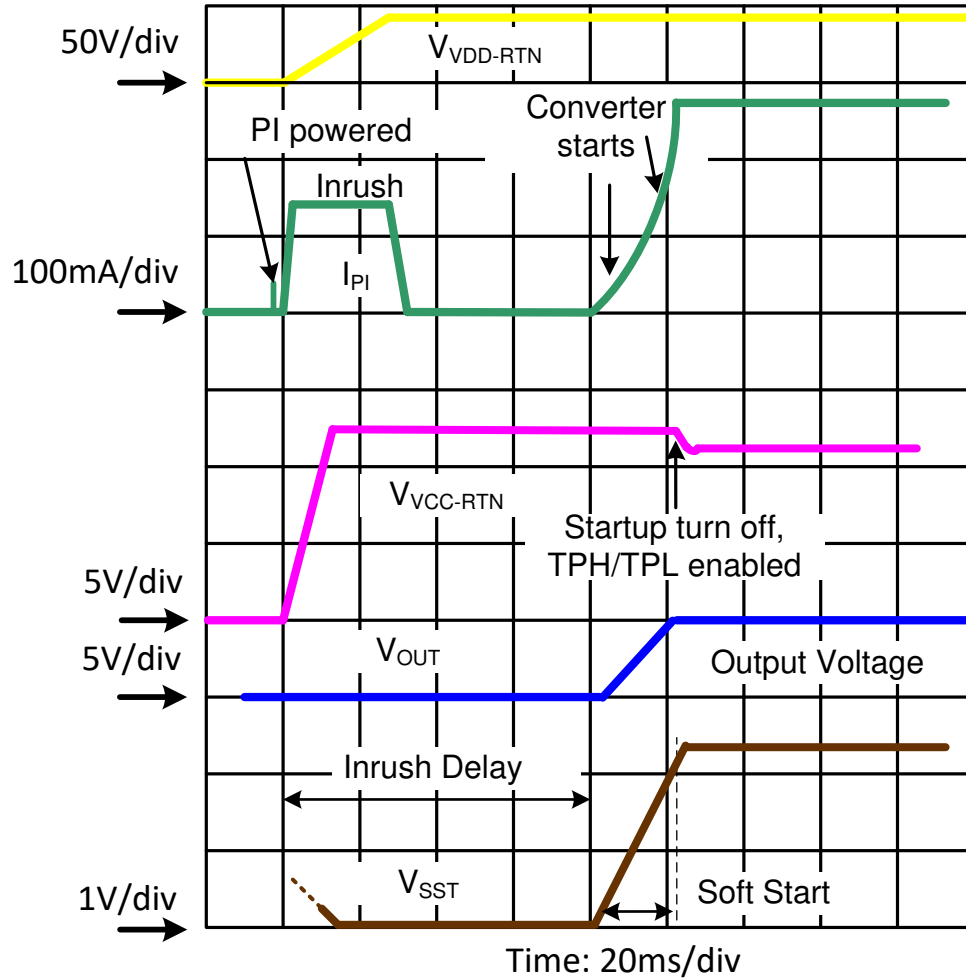
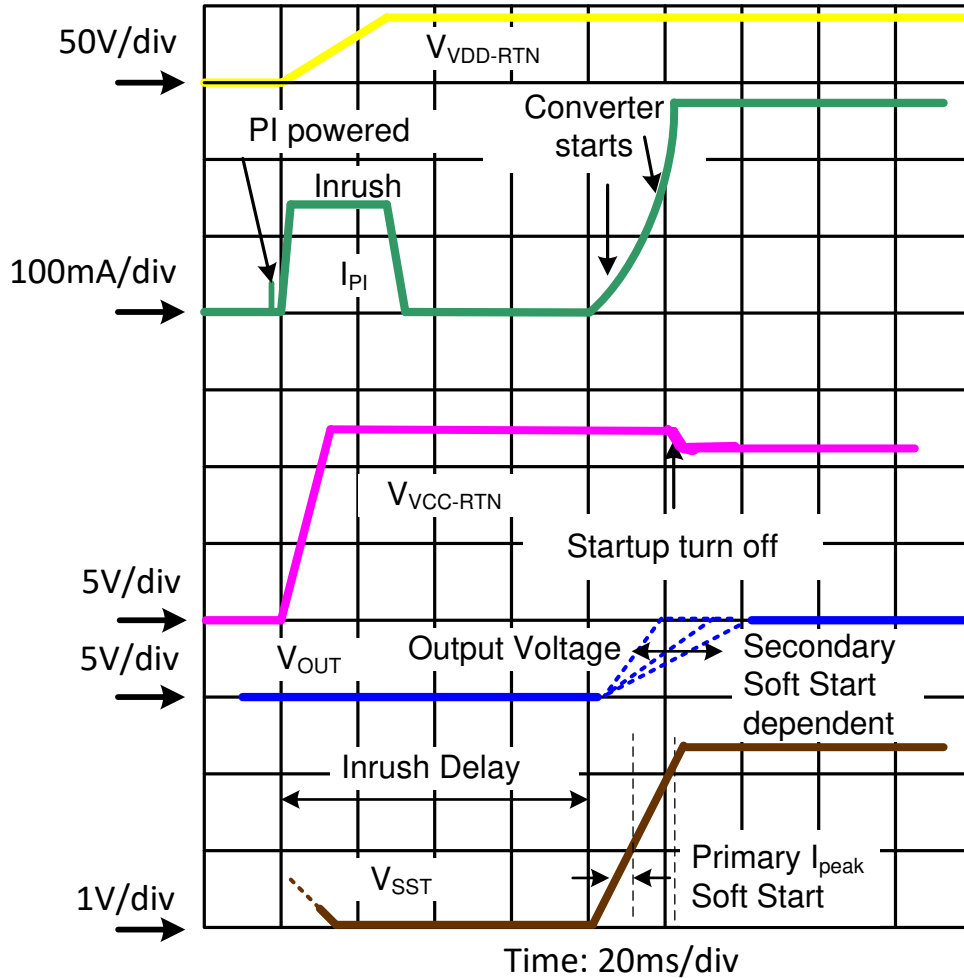

Figure 8-9. Power Up and Start - Flyback with PSR



**Figure 8-10. Power Up and Start - with Opto Feedback**

The converter shuts off when  $V_{VCC}$  falls below its lower UVLO. This can happen when power is removed from the PD, or during a fault on a converter output rail. When one output is shorted, all the output voltages fall including the one that powers VCC. The control circuit discharges VCC until it hits the lower UVLO and turns off. A restart initiates if the converter turns off and there is sufficient VDD voltage. This type of operation is sometimes referred to as *hiccup mode*, which when combined with the soft-start provides robust output short protection by providing time-average heating reduction of the output rectifier.

Figure 8-11 illustrates the situation when there is severe overload at the main output which causes VCC hiccup. After VCC went below its UVLO due to the overload, the startup source is turned back on. Then, a new soft-start cycle is reinitiated, the soft-start capacitor being first discharged with controlled current, introducing a short pause before the output voltage is ramped up.

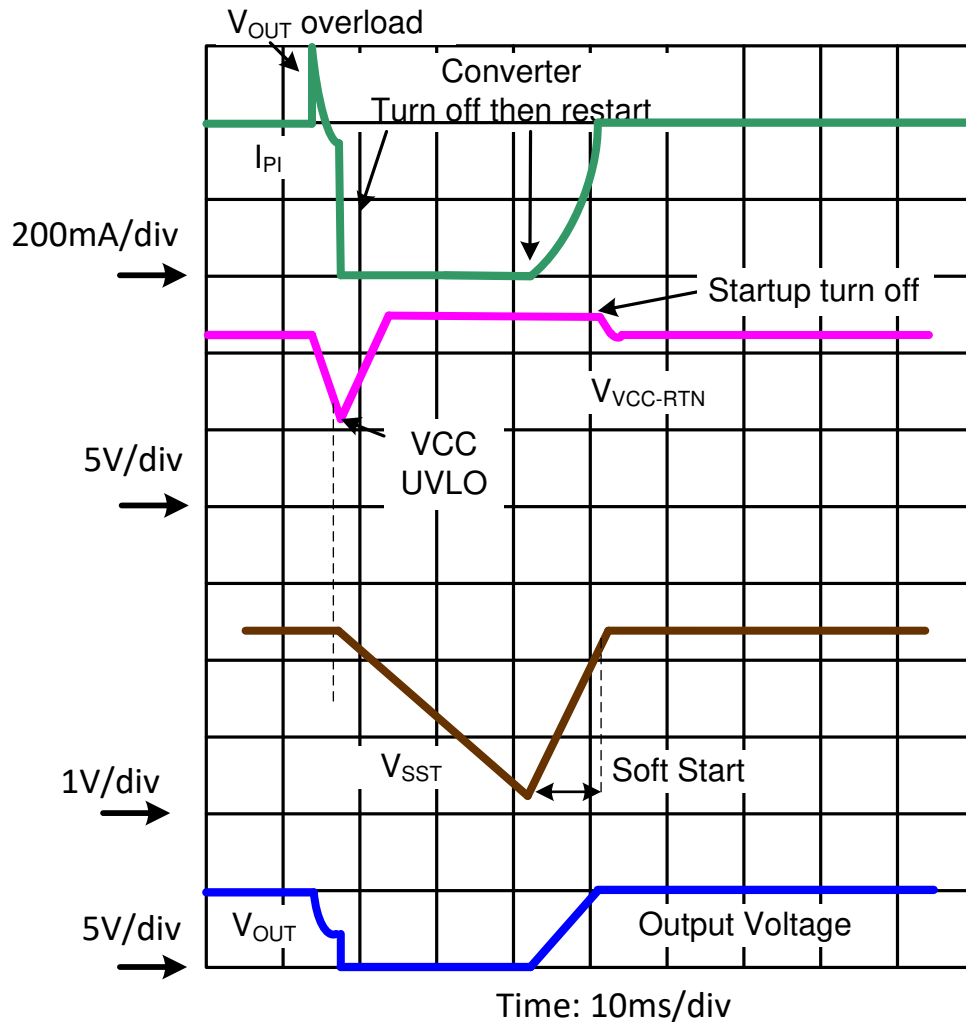

**Figure 8-11. Restart Following Severe Overload at Main Output of PSR Flyback DC-DC Converter**

Also, when a VCC fall occurs, the TPS23730 can differentiate between an overload and a light load condition. For example a diode-rectified flyback with optocoupled feedback may have its VCC rail to fall in situation of light load due to temporary switching stop. In this case, the output voltage has to be maintained and a soft-start would not be acceptable. To address this case, if  $V_{VCC}$  falls below approximately 7.1 V due to light load, the TPS23730 turns back on the startup immediately and for a short period of time to bring VCC voltage back up, and there is no soft-start recycling.

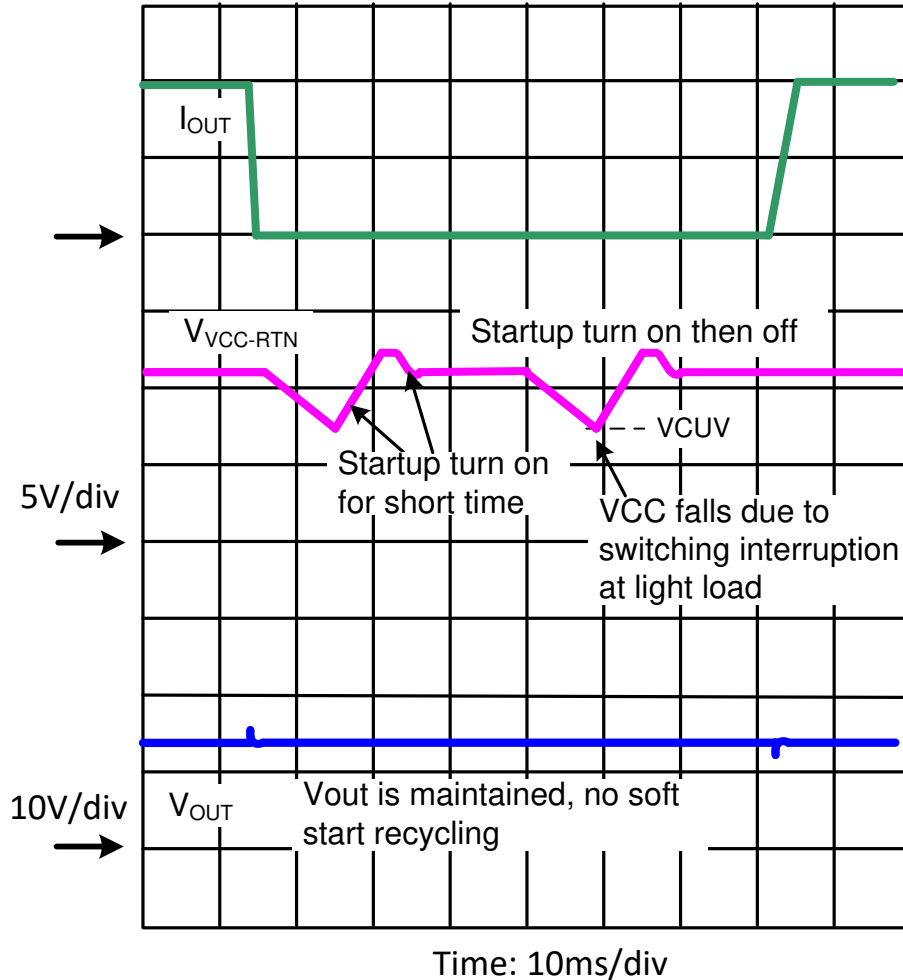

**Figure 8-12. Startup Operation if VCC Undervoltage is caused by Light Load Condition of Diode-rectified Flyback DC-DC Converter**

If  $V_{VDD-VSS}$  drops below the lower PoE UVLO ( $V_{UVLO\_F}$ , approximately 32 V), the hotswap MOSFET is turned off, but the converter still runs (unless LINEUV input is pulled low). The converter stops if  $V_{VCC}$  falls below the  $V_{CUVLO\_F}$  (~6.1 V), the hotswap is in inrush current limit, the SST pin is pulled to ground, or the converter is in thermal shutdown.

#### 8.4.8 Line Undervoltage Protection and Converter Operation

When the input power source is removed, there are circumstances where stress may occur on the power components. For example with ACF topology, as  $V_{VDD-RTN}$  gradually decreases the converter's operating duty cycle must compensate for the lower input voltage. At minimum input voltage the duty cycle nears its maximum value ( $D_{MAX}$ ), and the voltage across the clamp capacitor approaches its highest value since the transformer must be reset in a relatively short time. This results in potentially damaging overvoltage and oscillations. Also during next power up, due to precharged clamp capacitor, the soft-start could cause transformer saturation.

There are also situations where the output voltage capacitor may be able to back drive its secondary-side sync MOSFET(s) after the converter switching has stopped completely, either temporarily or not. Such situation could apply to both ACF and flyback (at power down or next soft-start) configurations.

To address this case, once the LINEUV voltage falls below  $V_{LIUVF}$ , the TPS23730 transitions to soft-stop mode. It turns on temporarily the startup to maintain  $V_{VCC}$ , then uses the SST control to ramp down the switching MOSFET peak current. As a result, the converter output is discharged in a controlled way, the energy of the output capacitor being sent back to the input bulk capacitor. Also note that at beginning of soft-stop, the

TPS23730 temporarily forces the peak current to a low value ( $V_{CS}$  maximum at approximately 50 mV), until SST voltage becomes low enough to decrease it further. This advanced feature allows the soft-stop to immediately start discharging the output capacitor, regardless of the output load level, minimizing any system tradeoffs for optimum switching MOSFETs protection. See [Figure 8-13](#).

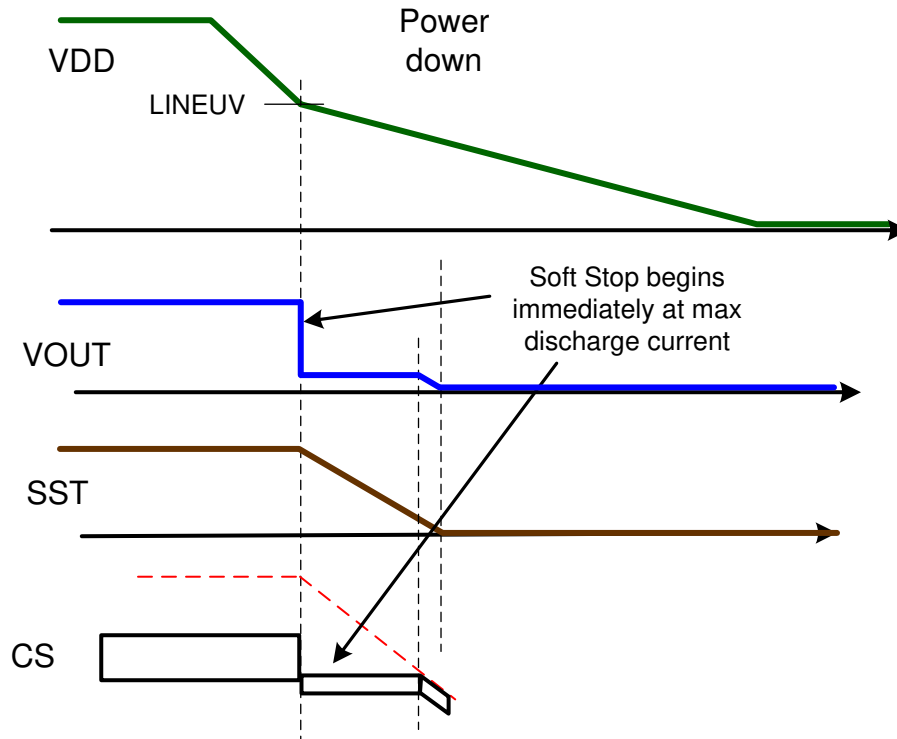

**Figure 8-13. Soft-Stop Operation**

Once the soft-stop operation has been completed and to avoid subsequent oscillations caused by the impact of the energy transfer on the LINEUV voltage, an internal load ( $\sim 7$  mA) is applied on VDD for approximately 160 ms, before the converter is allowed to restart.

#### 8.4.9 PD Self-Protection

IEEE802.3bt includes new PSE output limiting requirements for Type 3 and 4 operation to cover higher power and 4-pair applications. Type 2, 3 and 4 PSEs must meet an output current vs time template with specified minimum and maximum sourcing boundaries. The peak output current per each 2-pair may be as high as 50 A for 10  $\mu$ s or 1.75 A for 75 ms, and the total peak current becomes twice these values when power is delivered over 4 pairs. This makes robust protection of the PD device even more important than it was in IEEE 802.3-2012.

The PD section has the following self-protection functions.

- Hotswap switch current limit
- Hotswap switch foldback
- Hotswap thermal protection

The internal hotswap MOSFET of the TPS23730 is protected against output faults and input voltage steps with a current limit and deglitched foldback. High stress conditions include converter output shorts, shorts from VDD to RTN, or transients on the input line. An overload on the pass MOSFET engages the current limit, with  $V_{RTN-VSS}$  rising as a result. If  $V_{RTN}$  rises above approximately 14.8 V for longer than approximately 1.8 ms, the current limit reverts to the inrush limit, and turns the converter off, although there is no minimum inrush delay period (84 ms) applicable in this case. The 1.8-ms deglitch feature prevents momentary transients from causing a PD reset, provided that recovery lies within the bounds of the hotswap and PSE protection. [Figure 8-14](#) shows an example of recovery from a 15-V PSE rising voltage step. The hotswap MOSFET goes into current limit, overshooting to



a relatively low current, recovers to 1.85-A full current limit, and charges the input capacitor while the converter continues to run. The MOSFET did not go into foldback because  $V_{RTN-VSS}$  was below 14.8 V after the 1.8-ms deglitch.

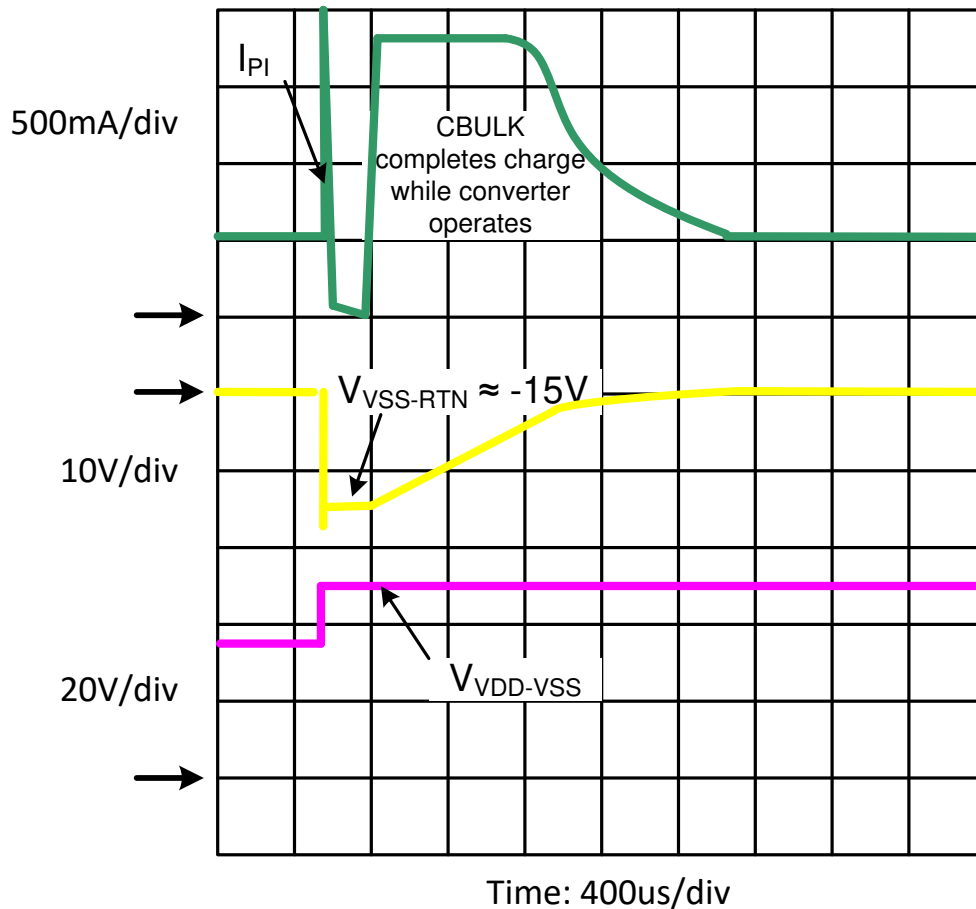

**Figure 8-14. Response to PSE Step Voltage**

The PD control has a thermal sensor that protects the internal hotswap MOSFET. Conditions like start-up or operation into a VDD to RTN short cause high power dissipation in the MOSFET. An overtemperature shutdown (OTSD) turns off the hotswap MOSFET and class regulator, which are restarted after the device cools. The PD restarts in inrush phase when exiting from a PD overtemperature event.

Pulling DEN to VSS during powered operation causes the internal hotswap MOSFET to turn off. This feature allows a PD with secondary-side adapter ORing to achieve adapter priority. Take care with synchronous converter topologies that can deliver power in both directions.

The hotswap switch is forced off under the following conditions:

- $V_{APD}$  above  $V_{APDEN}$  (approximately 1.5 V)
- $V_{DEN} \leq V_{PD\_DIS}$  when  $V_{VDD-VSS}$  is in the operational range
- PD over temperature
- $V_{VDD-VSS} < \text{PoE UVLO}$  (approximately 32 V)

#### 8.4.10 Thermal Shutdown - DC-DC Controller

The DC-DC controller has an OTSD that can be triggered by heat sources including the VB and VBG regulators, GATE/GAT2 drivers, startup current source, and bias currents. The controller OTSD turns off VB, VBG, the GATE/GAT2 drivers, and forces the VCC control into an under-voltage state.

### 8.4.11 Adapter ORing

Many PoE-capable devices are designed to operate from either a wall adapter or PoE power. A local power solution adds cost and complexity, but allows a product to be used if PoE is not available in a particular installation. While most applications only require that the PD operate when both sources are present, the TPS23730 device supports forced operation from either of the power sources. Figure 8-15 illustrates three options for diode ORing external power into a PD. Only one option would be used in any particular design. Option 1 applies power to the device input, option 2 applies power between the device PoE section and the power circuit, and option 3 applies power to the output side of the converter. Each of these options has advantages and disadvantages. A detailed discussion of the device and ORing solutions is covered in application note *Advanced Adapter ORing Solutions using the TPS23753*, (SLVA306).

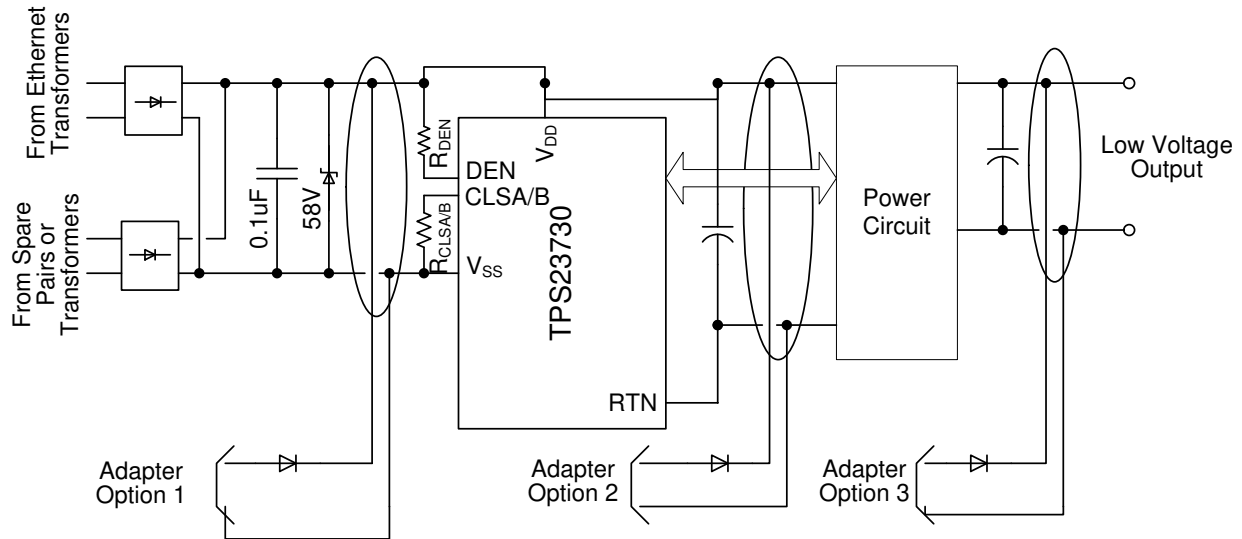

Figure 8-15. ORing Configurations

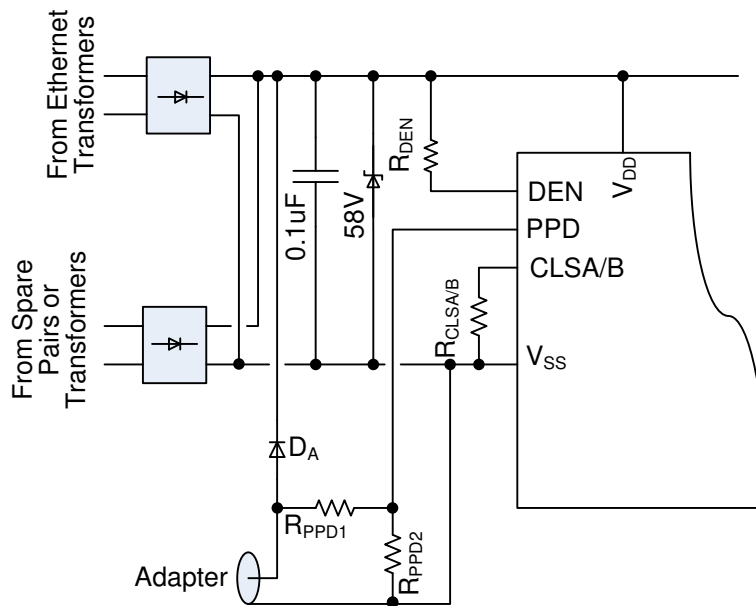

Figure 8-16. Low-Voltage Option 1 ORing

Preference of one power source presents a number of challenges. Combinations of adapter output voltage (nominal and tolerance), power insertion point, and which source is preferred determine solution complexity. Several factors contributing to the complexity are the natural high-voltage selection of diode ORing (the simplest

method of combining sources), the current limit implicit in the PSE, PD inrush, and protection circuits (necessary for operation and reliability). Creating simple and seamless solutions is difficult if not impossible for many of the combinations. However, the TPS23730 device offers several built-in features that simplify some combinations.

Several examples demonstrate the limitations inherent in ORing solutions. Diode ORing a 48-V adapter with PoE (option 1) presents the problem that either source may have the higher voltage. A blocking switch would be required to assure that one source dominates. A second example is combining a 12-V adapter with PoE using option 2. The converter draws approximately four times the current at 12 V from the adapter than it does from PoE at 48 V. Transition from adapter power to PoE may demand more current than can be supplied by the PSE. The converter must be turned off while  $C_{IN}$  capacitance charges, with a subsequent converter restart at the higher voltage and lower input current. A third example is use of a 24-V adapter with ORing option 1. The PD hotswap would have to handle two times the current, and have 1/4 the resistance (be 4 times larger) to dissipate equal power.

The most popular preferential ORing scheme is option 2 with adapter priority. The hotswap MOSFET is disabled when the adapter is used to pull APD high, blocking the PoE source from powering the output. This solution works well with a wide range of adapter voltages, is simple, and requires few external parts. When the AC power fails, or the adapter is removed, the hotswap switch is enabled. In the simplest implementation, the PD momentarily loses power until the PSE completes its start-up cycle.

The DEN pin can be used to disable the PoE input when ORing with option 3. This is an adapter priority implementation. Pulling DEN low, while creating an invalid detection signature, disables the hotswap MOSFET, and prevents the PD from redetecting. This would typically be accomplished with an optocoupler that is driven from the secondary side of the converter. Another option 3 alternative which does not require DEN optocoupler is achievable by ensuring that the auxiliary voltage is always higher than the converter output; in this case, the PSE power can then be maintained by use of the auto MPS function of the TPS23730.

The TPS23730 also supports the use of an option 1 adapter, for example 24-V, by use of the PPD input. See [Figure 8-16](#).

The IEEE standards require that the PI conductors be electrically isolated from ground and all other system potentials not part of the PI interface. The adapter must meet a minimum 1500-Vac dielectric withstand test between the output and all other connections for options 1 and 2. The adapter only needs this isolation for option 3 if it is not provided by the converter.

Adapter ORing diodes are shown for all the options to protect against a reverse-voltage adapter, a short on the adapter input pins, and damage to a low-voltage adapter. ORing is sometimes accomplished with a MOSFET in option 3.

## 9 Application and Implementation

### Note

Information in the following applications sections is not part of the TI component specification, and TI does not warrant its accuracy or completeness. TI's customers are responsible for determining suitability of components for their purposes, as well as validating and testing their design implementation to confirm system functionality.

### 9.1 Application Information

The TPS23730 has the flexibility to support many power supply topologies that require a single PWM gate drive or two complementary gate drives and will operate with current-mode control. Figure 9-1 provides an example of an active clamp forward converter.

### 9.2 Typical Application

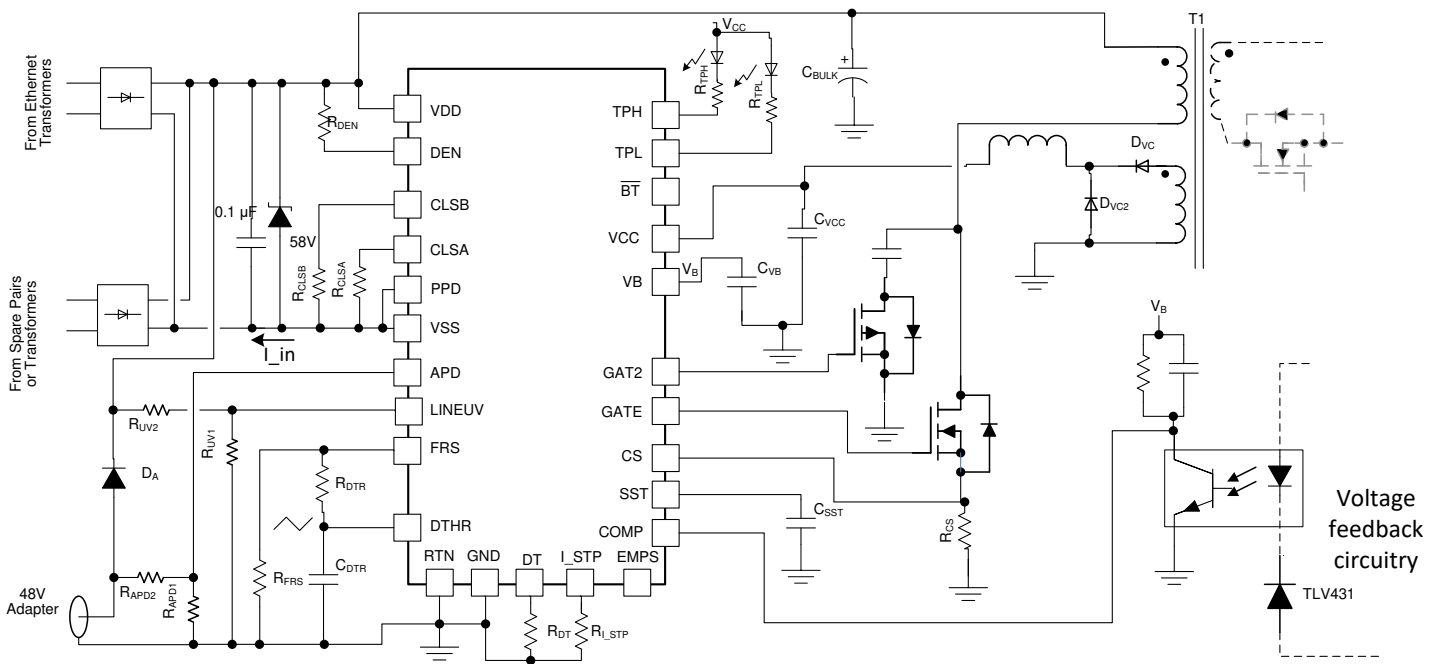

Figure 9-1. Basic TPS23730 Implementation

## 9.2.1 Design Requirements

Selecting a converter topology along with a converter design procedure is beyond the scope of this application section.

The TPS23730 has the flexibility to be used in high power density flyback topologies such as primary side regulation synchronous or non-synchronous flyback.

Examples to help in programming the TPS23730 and additional design consideration are shown in [Detailed Design Procedure](#). For a more specific converter design example, refer to the TPS23730EVM-093 EVM that is designed for the design parameters in [Table 9-1](#).

**Table 9-1. Design Parameters**

PARAMETER	TEST CONDITIONS	MIN	TYPICAL	MAX	UNIT
Input voltage	Power applied through PoE or adapter	0		57	V
Operating voltage	After startup	30		57	V
Adapter voltage		40		57	V
Input UVLO	Rising input voltage at device terminals	—		40	V
	Falling input voltage	30.5		—	
Detection voltage	At device terminals	1.4		10.1	V
Classification voltage	At device terminals	11.9		23	V
Class 4	Class signature A	38		42	mA
DCDC Topology	Active Clamp Forward				
Output Voltage			12		V
Output Current			3.9		A
End-to-End Efficiency	At full load		91		%
Switching Frequency			250		kHz

### 9.2.1.1 Detailed Design Procedure

#### 9.2.1.1.1 Input Bridges and Schottky Diodes

Using Schottky diodes instead of PN junction diodes for the PoE input bridges will reduce the power loss by about 30%. These are often used to maximize the efficiency when FET bridge architectures are not used.

Schottky diode leakage current and different input bridge architectures can impact the detection signature. Setting reasonable expectations for the temperature range over which the detection signature is accurate is the simplest solution. Adjusting  $R_{DEN}$  slightly may also help meet the requirement.

A general recommendation for the input rectifiers are 2 A, 100-V rated discrete or bridge schottky diodes.

The TPS23730EVM-093 allows the option of either a discrete schottky bridge or a FET-Diode bridge for 1-2% higher overall system efficiency.

#### 9.2.1.1.2 Input TVS Protection

A TVS, across the rectified PoE voltage must be used. TI recommends a SMAJ58A, or a part with equal to or better performance, for general indoor applications. If an adapter is connected from  $V_{DD}$  to RTN, as in ORing option 2 above, voltage transients caused by the input cable inductance ringing with the internal PD capacitance can occur. Adequate capacitive filtering or a TVS must limit this voltage to be within the absolute maximum ratings. Outdoor transient levels or special applications require additional protection.

ESD events between the PD power inputs and converter output, cause large stresses in the hotswap MOSFET if the input TVS becomes reverse biased and transient current around the TPS23730 is blocked. A SMAJ58A is a good initial selection between RTN (cathode) and VSS (anode).

#### 9.2.1.1.3 Input Bypass Capacitor

The IEEE 802.3bt standard specifies an input bypass capacitor (from  $V_{DD}$  to  $V_{SS}$ ) of 0.05  $\mu$ F to 0.12  $\mu$ F. Typically a 0.1- $\mu$ F, 100-V, 10% ceramic capacitor is used.

#### 9.2.1.1.4 Detection Resistor, $R_{DEN}$

The IEEE 802.3bt standard specifies a detection signature resistance,  $R_{DEN}$  from 23.7 k $\Omega$  to 26.3 k $\Omega$ , or 25 k $\Omega$   $\pm$  5%. Choose an  $R_{DEN}$  of 25.5 k $\Omega$ .

#### 9.2.1.1.5 Classification Resistor, $R_{CLSA}$ and $R_{CLSB}$

Connect a resistor from CLSA and CLSB to  $V_{SS}$  to program the classification current according to the IEEE 802.3bt standard. The class power assigned should correspond to the maximum average power drawn by the PD during operation. Select  $R_{CLSx}$  according to [Table 8-1](#).

For a high-power design, choose Class 6 where  $R_{CLSA} = 32 \Omega$  and  $R_{CLSB} = 130 \Omega$ .

#### 9.2.1.1.6 Dead Time Resistor, $R_{DT}$

Program the dead time with a resistor connected from DT to RTN. The required dead-time period depends on the specific topology and parasitics. The easiest technique to obtain the optimum timing resistor is to build the supply. A good initial value is 100 ns. Then the dead time can be tuned to achieve the best efficiency after considering all corners of operation (load, input voltage, and temperature).

1. Choose  $R_{DT}$  as follows assuming a  $t_{DT}$  of 100 ns:

$$a. \quad R_{DT}(k\Omega) = \frac{t_{DT}(ns)}{2} = \frac{100}{2} = 50$$

- b. Choose  $R_{DT} = 49.9 \text{ k}\Omega$

#### 9.2.1.1.7 APD Pin Divider Network, $R_{APD1}$ , $R_{APD2}$

The APD pin can be used to disable the TPS23730 device internal hotswap MOSFET giving the adapter source priority over the PoE source. An example calculation is provided, see [SLVA306](#).

#### 9.2.1.1.8 PPD Pin Divider Network, $R_{PPD1}$ , $R_{PPD2}$

For this design example, passive PoE is not required so PPD is pulled down to  $V_{SS}$ . However, the PPD pin can be used to override the internal hotswap MOSFET UVLO ( $V_{UVLO\_R}$  and  $V_{UVLO\_H}$ ) when using low voltage adapters connected between  $V_{DD}$  and  $V_{SS}$ . The PPD pin has an internal 5- $\mu$ A pulldown current source. As an example, consider the choice of  $R_{PPD1}$  and  $R_{PPD2}$ , for a 24-V adapter.

1. Select the start-up voltage,  $V_{ADPTR-ON}$  approximately 75% of nominal for a 24-V adapter. Assuming that the adapter output is 24 V  $\pm$  10%, this provides 15% margin below the minimum adapter operating voltage.
2. Choose  $V_{ADPTR-ON} = 24 \text{ V} \times 0.75 = 18 \text{ V}$ .
3. Choose  $R_{PPD2} = 3.01 \text{ k}\Omega$ .
4.  $I_{RPPD1} = I_{RPPD2} + 5 \mu\text{A}$  so  $R_{PPD1}$  can be calculated using KCL. Choose 18.7 k $\Omega$ .

#### 9.2.1.1.9 Setting Frequency ( $R_{FRS}$ ) and Synchronization

The converter switching frequency is set by connecting  $R_{FRS}$  from the FRS pin to AGND.

As an example:

1. Optimal switching frequency ( $f_{SW}$ ) for isolated PoE applications is 250 kHz.
2. Compute  $R_{FRS}$  per [Equation 2](#).
3. Select 60.4 k $\Omega$ .

The TPS23730 device may be synchronized to an external clock to eliminate beat frequencies from a sampled system, or to place emission spectrum away from an RF input frequency. Synchronization may be accomplished by applying a short pulse ( $T_{SYNC}$ ) of magnitude  $V_{SYNC}$  to FRS as shown in [Figure 8-3](#).  $R_{FRS}$  should be chosen so that the maximum free-running frequency is just below the desired synchronization frequency. The synchronization pulse terminates the potential on-time period, and the off-time period does not begin until the pulse terminates. The pulse at the FRS pin should reach between 2.5 V and  $V_B$ , with a minimum width of 25 ns (above 2.5 V) and rise and fall times less than 10 ns. The FRS node should be protected from noise because it is high-impedance. An  $R_T$  on the order of 100  $\Omega$  in the isolated example reduces noise sensitivity and jitter.

### 9.2.1.1.10 Bias Supply Requirements and $C_{VCC}$

Advanced startup in the TPS23730 allows for relatively low capacitance on the bias circuit. It is recommended to use a 1- $\mu$ F 10% 25-V ceramic capacitor on  $C_{VCC}$ .

### 9.2.1.1.11 TPH, TPL, and BT Interface

The TPH, TPL and  $\overline{BT}$  pins are active low, open-drain outputs which give an indication about the PSE allocated power. Optocouplers can interface these pins to circuitry on the secondary side of the converter. A high-gain optocoupler and a high-impedance (for example, CMOS) receiver are recommended. Please see the TPS23730EVM-093 as an example circuit. Below is an example design calculation.

- Let  $V_{CC} = 12\text{-V}$ ,  $V_{OUT} = 5\text{-V}$ ,  $R_{TPX-OUT} = 10\text{-k}\Omega$ ,  $V_{TPX-OUT}(\text{low}) = 400\text{-mV}$  maximum.
  - $I_{TPX-OUT} = 0.46\text{ mA}$ .
- The optocoupler CTR will be needed to determine  $R_{TPX}$ . A device with a minimum CTR of 300% at 5-mA LED bias current is selected. CTR will also vary with temperature and LED bias current. The strong variation of CTR with diode current makes this a problem that requires some iteration using the CTR versus  $I_{DIODE}$  curve on the optocoupler data sheet.
  - The approximate forward voltage of the optocoupler diode is 1.1 V from the data sheet.
  - $I_{TPX-MIN} = 1\text{ mA}$  and  $R_{TPX} = 10.6\text{ k}\Omega$ .
- Select 10.7-k $\Omega$  resistor.

### 9.2.1.1.12 Secondary Soft Start

Converters require a soft start on the voltage error amplifier to prevent output overshoot on start-up. [Figure 9-2](#) shows a common implementation of a secondary-side soft start that works with the typical TLV431 error amplifier. The soft-start components consist of  $D_{SS}$ ,  $R_{SS}$ , and  $C_{SS}$ . They serve to control the output rate-of-rise by pulling  $V_{COMP}$  down as  $C_{SS}$  charges through  $R_{OB}$ , the optocoupler, and  $D_{SS}$ . This has the added advantage that the TLV431 output and  $C_{IZ}$  are preset to the proper value as the output voltage reaches the regulated value, preventing voltage overshoot due to the error amplifier recovery. The secondary-side error amplifier will not become active until there is sufficient voltage on the secondary. The TPS23730 provides an adjustable primary-side soft start, which persists long enough for secondary side voltage-loop soft start to take over. The primary-side current-loop soft start controls the switching MOSFET peak current by applying a slowly rising ramp voltage to a second PWM control input. The PWM is controlled by the lower of the soft-start ramp or the COMP-derived current demand. The actual output voltage rise time is usually much shorter than the internal soft-start period. Initially the primary soft-start ramp limits the maximum current demand as a function of time. Either the current limit, secondary-side soft start, or output regulation assume control of the PWM before the primary soft-start period is over. Since the VCC startup source stays on longer after converter's output voltage is ramped up (VCC startup turns off only when 2.1 V is reached on the SS pin), a large bias winding hold up capacitor is not necessary like in some traditional PWM controllers. Instead, this allows for a small 1- $\mu$ F ceramic capacitor to be used on VCC.

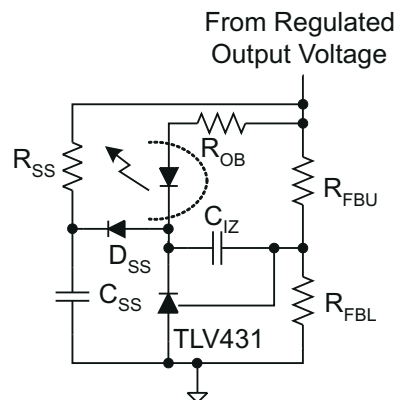

Figure 9-2. Error Amplifier Soft Start

#### 9.2.1.1.13 Frequency Dithering for Conducted Emissions Control

For optimum EMI performance,  $C_{DTR}$  and  $R_{DTR}$  should be calculated as described in [DTHR and Frequency Dithering for Spread Spectrum Applications](#).

These equations yield  $C_{DTR} = 2.2 \text{ nF}$  and  $R_{DTR} = 235 \text{ k}\Omega$  where a 237-k $\Omega$  standard resistor can be used.



## 10 Power Supply Recommendations

The TPS23730 converter must be designed such that the input voltage of the converter is capable of operating within the IEEE 802.3 protocol at the recommended input voltage as shown in [Table 8-4](#) and the minimum operating voltage of the adapter if applicable.

## 11 Layout

### 11.1 Layout Guidelines

The layout of the PoE front end should follow power and EMI/ESD best practice guidelines. A basic set of recommendations include:

- Parts placement must be driven by power flow in a point-to-point manner; RJ-45, Ethernet transformer, diode bridges, TVS and 0.1- $\mu$ F capacitor, and TPS23730.
- All leads should be as short as possible with wide power traces and paired signal and return.
- There should not be any crossovers of signals from one part of the flow to another.
- Spacing consistent with safety standards like IEC60950 must be observed between the 48-V input voltage rails and between the input and an isolated converter output.
- The TPS23730 should be located over split, local ground planes referenced to VSS for the PoE input and to RTN for the switched output.
- Large copper fills and traces should be used on SMT power-dissipating devices, and wide traces or overlay copper fills should be used in the power path.
- It is recommended having at least 8 vias (PAD\_G) and 5 vias on (PAD\_S) connecting the exposed thermal pad through a top layer plane (2-oz. copper recommended) to a bottom VSS plane (2-oz. copper recommended) to help with thermal dissipation.

### 11.2 Layout Example

A detailed PCB layout can be found in the user's guide of the TPS23730EVM-093 that show the top and bottom layer and assemblies as a reference for optimum parts placement.

### 11.3 EMI Containment

- Use compact loops for dv/dt and di/dt circuit paths (power loops and gate drives).
- Use minimal, yet thermally adequate, copper areas for heat sinking of components tied to switching nodes (minimize exposed radiating surface).
- Use copper ground planes (possible stitching) and top layer copper floods (surround circuitry with ground floods).
- Use 4 layer PCB if economically feasible (for better grounding).
- Minimize the amount of copper area associated with input traces (to minimize radiated pickup).
- Use Bob Smith terminations, Bob Smith EFT capacitor, and Bob Smith plane.
- Use Bob Smith plane as ground shield on input side of PCB (creating a phantom or literal earth ground).
- Use of ferrite beads on input (allow for possible use of beads or 0- $\Omega$  resistors).
- Maintain physical separation between input-related circuitry and power circuitry (use ferrite beads as boundary line).
- Possible use of common-mode inductors.
- Possible use of integrated RJ-45 jacks (shielded with internal transformer and Bob Smith terminations).
- End-product enclosure considerations (shielding).

### 11.4 Thermal Considerations and OTSD

Sources of nearby local PCB heating should be considered during the thermal design. Typical calculations assume that the TPS23730 is the only heat source contributing to the PCB temperature rise. It is possible for a normally operating TPS23730 device to experience an OTSD event if it is excessively heated by a nearby device.

### 11.5 ESD

ESD requirements for a unit that incorporates the TPS23730 have a much broader scope and operational implications than are used in TI's testing. Unit-level requirements should not be confused with reference design testing that only validates the ruggedness of the TPS23730.

## 12 Device and Documentation Support

### 12.1 Documentation Support

#### 12.1.1 Related Documentation

For related documentation, see the following:

- *IEEE Standard for Information Technology ... Part 3: Carrier sense multiple access with collision detection (CSMA/CD) access method and physical layer specifications*, IEEE Computer Society, IEEE 802.3™ at (Clause 33)
- *Information technology equipment – Radio disturbance characteristics – Limits and methods of measurement*, International Electrotechnical Commission, CISPR 22 Edition 5.2, 2006-03
- *Advanced Adapter ORing Solutions using the TPS23753*, Eric Wright, TI, [SLVA306](#)
- *Practical Guidelines to Designing an EMI-Compliant PoE Powered Device With Isolated Flyback*, Donald V. Comiskey, TI, [SLUA469](#)
- *TPS23730EVM-093: Evaluation Module for TPS23730*

#### 12.2 Support Resources

[TI E2E™ support forums](#) are an engineer's go-to source for fast, verified answers and design help — straight from the experts. Search existing answers or ask your own question to get the quick design help you need.

Linked content is provided "AS IS" by the respective contributors. They do not constitute TI specifications and do not necessarily reflect TI's views; see TI's [Terms of Use](#).

#### 12.3 Trademarks

TI E2E™ is a trademark of Texas Instruments.

All trademarks are the property of their respective owners.

#### 12.4 Electrostatic Discharge Caution



This integrated circuit can be damaged by ESD. Texas Instruments recommends that all integrated circuits be handled with appropriate precautions. Failure to observe proper handling and installation procedures can cause damage.

ESD damage can range from subtle performance degradation to complete device failure. Precision integrated circuits may be more susceptible to damage because very small parametric changes could cause the device not to meet its published specifications.

#### 12.5 Glossary

[TI Glossary](#) This glossary lists and explains terms, acronyms, and definitions.

## 13 Mechanical, Packaging, and Orderable Information

The following pages include mechanical, packaging, and orderable information. This information is the most current data available for the designated devices. This data is subject to change without notice and revision of this document. For browser-based versions of this data sheet, refer to the left-hand navigation.

**PACKAGING INFORMATION**

Orderable Device	Status (1)	Package Type	Package Drawing	Pins	Package Qty	Eco Plan (2)	Lead finish/ Ball material (6)	MSL Peak Temp (3)	Op Temp (°C)	Device Marking (4/5)	Samples
TPS23730RMTR	ACTIVE	VQFN	RMT	45	3000	RoHS & Green	NIPDAU	Level-3-260C-168 HR	-40 to 125	TPS23730 DB0 WA1	

(1) The marketing status values are defined as follows:

**ACTIVE:** Product device recommended for new designs.

**LIFEBUY:** TI has announced that the device will be discontinued, and a lifetime-buy period is in effect.

**NRND:** Not recommended for new designs. Device is in production to support existing customers, but TI does not recommend using this part in a new design.

**PREVIEW:** Device has been announced but is not in production. Samples may or may not be available.

**OBsolete:** TI has discontinued the production of the device.

(2) **RoHS:** TI defines "RoHS" to mean semiconductor products that are compliant with the current EU RoHS requirements for all 10 RoHS substances, including the requirement that RoHS substance do not exceed 0.1% by weight in homogeneous materials. Where designed to be soldered at high temperatures, "RoHS" products are suitable for use in specified lead-free processes. TI may reference these types of products as "Pb-Free".

**RoHS Exempt:** TI defines "RoHS Exempt" to mean products that contain lead but are compliant with EU RoHS pursuant to a specific EU RoHS exemption.

**Green:** TI defines "Green" to mean the content of Chlorine (Cl) and Bromine (Br) based flame retardants meet JS709B low halogen requirements of <=1000ppm threshold. Antimony trioxide based flame retardants must also meet the <=1000ppm threshold requirement.

(3) MSL, Peak Temp. - The Moisture Sensitivity Level rating according to the JEDEC industry standard classifications, and peak solder temperature.

(4) There may be additional marking, which relates to the logo, the lot trace code information, or the environmental category on the device.

(5) Multiple Device Markings will be inside parentheses. Only one Device Marking contained in parentheses and separated by a "~" will appear on a device. If a line is indented then it is a continuation of the previous line and the two combined represent the entire Device Marking for that device.

(6) Lead finish/Ball material - Orderable Devices may have multiple material finish options. Finish options are separated by a vertical ruled line. Lead finish/Ball material values may wrap to two lines if the finish value exceeds the maximum column width.

**Important Information and Disclaimer:**The information provided on this page represents TI's knowledge and belief as of the date that it is provided. TI bases its knowledge and belief on information provided by third parties, and makes no representation or warranty as to the accuracy of such information. Efforts are underway to better integrate information from third parties. TI has taken and continues to take reasonable steps to provide representative and accurate information but may not have conducted destructive testing or chemical analysis on incoming materials and chemicals. TI and TI suppliers consider certain information to be proprietary, and thus CAS numbers and other limited information may not be available for release.

In no event shall TI's liability arising out of such information exceed the total purchase price of the TI part(s) at issue in this document sold by TI to Customer on an annual basis.

## TAPE AND REEL INFORMATION



### QUADRANT ASSIGNMENTS FOR PIN 1 ORIENTATION IN TAPE



\*All dimensions are nominal

Device	Package Type	Package Drawing	Pins	SPQ	Reel Diameter (mm)	Reel Width W1 (mm)	A0 (mm)	B0 (mm)	K0 (mm)	P1 (mm)	W (mm)	Pin1 Quadrant
TPS23730RMTR	VQFN	RMT	45	3000	330.0	16.4	5.25	7.25	1.45	8.0	16.0	Q1

**TAPE AND REEL BOX DIMENSIONS**

\*All dimensions are nominal

Device	Package Type	Package Drawing	Pins	SPQ	Length (mm)	Width (mm)	Height (mm)
TPS23730RMTR	VQFN	RMT	45	3000	367.0	367.0	35.0

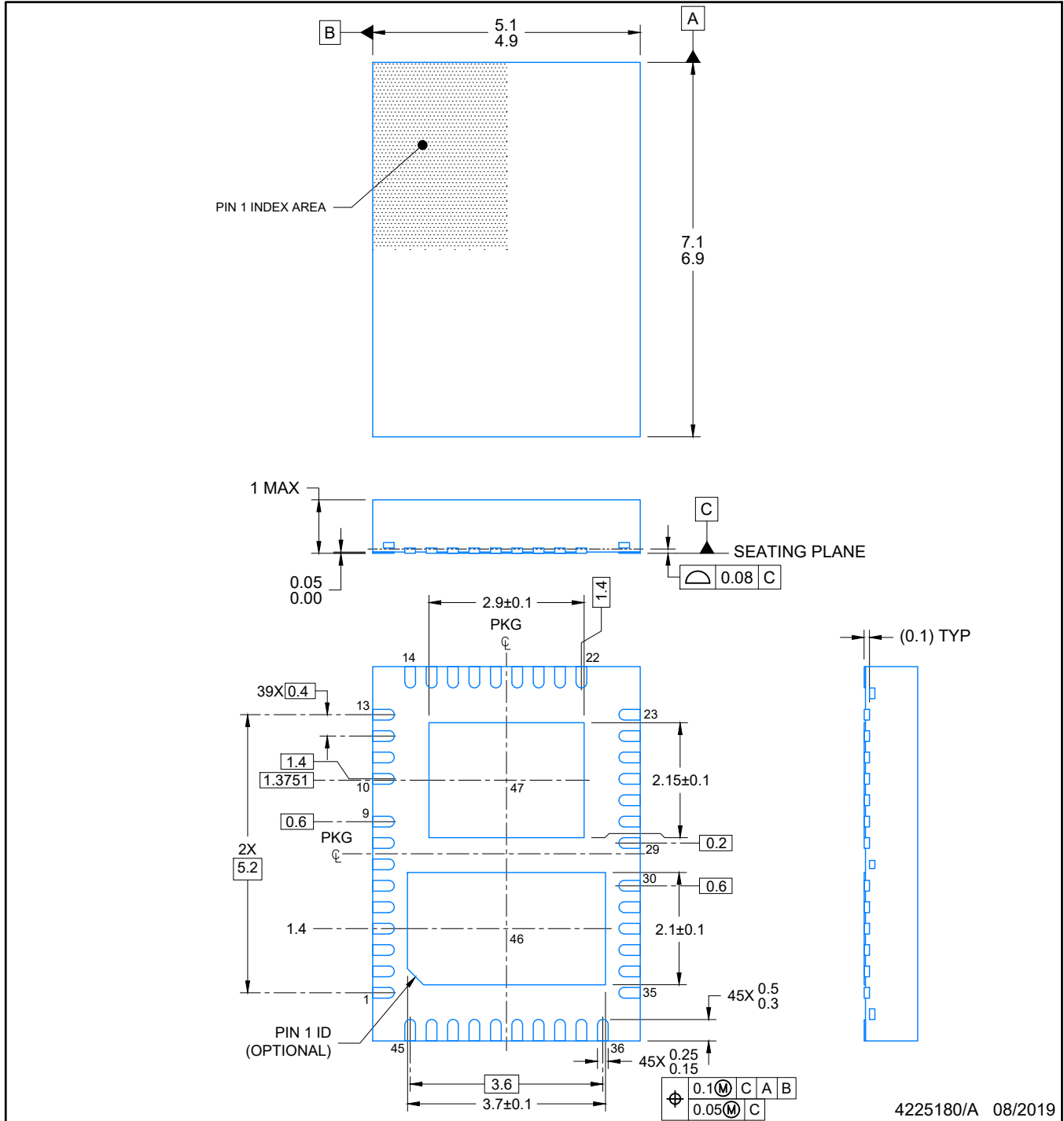

NOTES:

1. All linear dimensions are in millimeters. Any dimensions in parenthesis are for reference only. Dimensioning and tolerancing per ASME Y14.5M.
2. This drawing is subject to change without notice.
3. The package thermal pad must be soldered to the printed circuit board for optimal thermal and mechanical performance.

# EXAMPLE BOARD LAYOUT

RMT0045A

VQFN - 1 mm max height

PLASTIC QUAD FLATPACK-NO LEAD

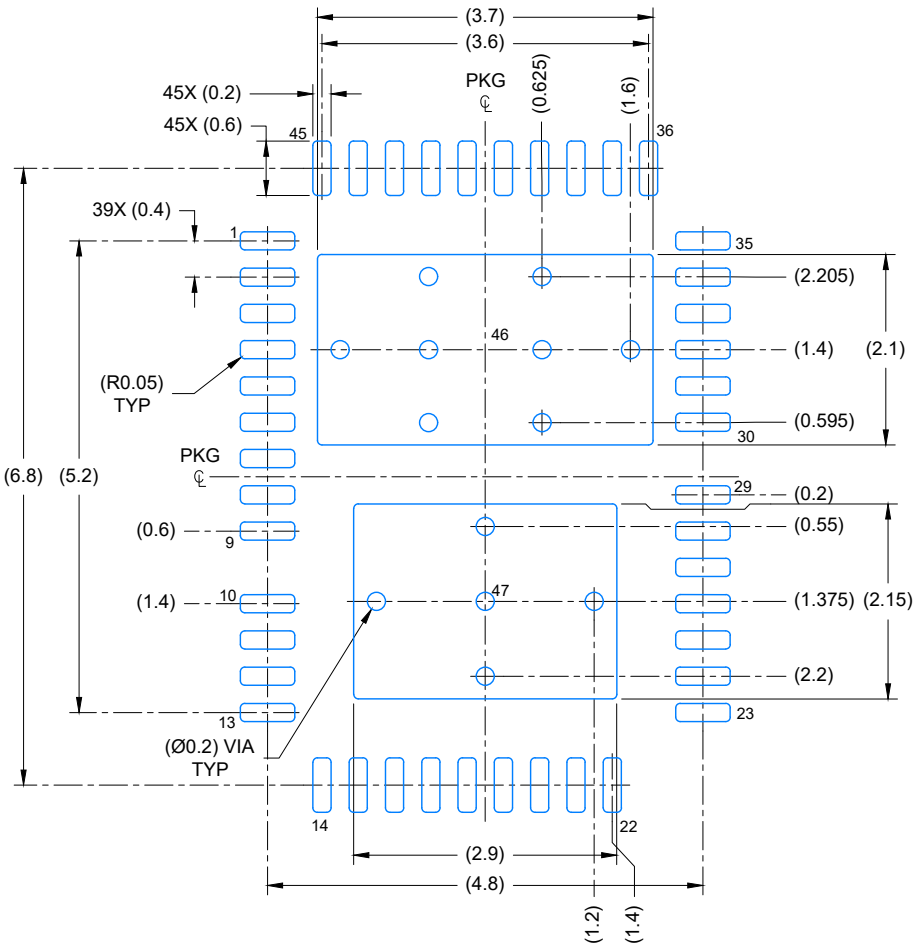

LAND PATTERN EXAMPLE  
EXPOSED METAL SHOWN  
SCALE: 12X

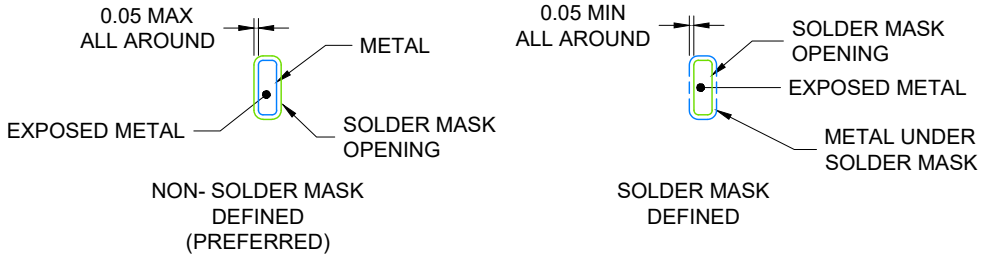

SOLDER MASK DETAILS

4225180/A 08/2019

NOTES: (continued)

4. This package is designed to be soldered to a thermal pad on the board. For more information, see Texas Instruments literature number SLUA271 ([www.ti.com/lit/slua271](http://www.ti.com/lit/slua271)).
5. Vias are optional depending on application, refer to device data sheet. If any vias are implemented, refer to their locations shown on this view. It is recommended that vias under paste be filled, plugged or tented.



# EXAMPLE STENCIL DESIGN

RMT0045A

VQFN - 1 mm max height

PLASTIC QUAD FLATPACK-NO LEAD

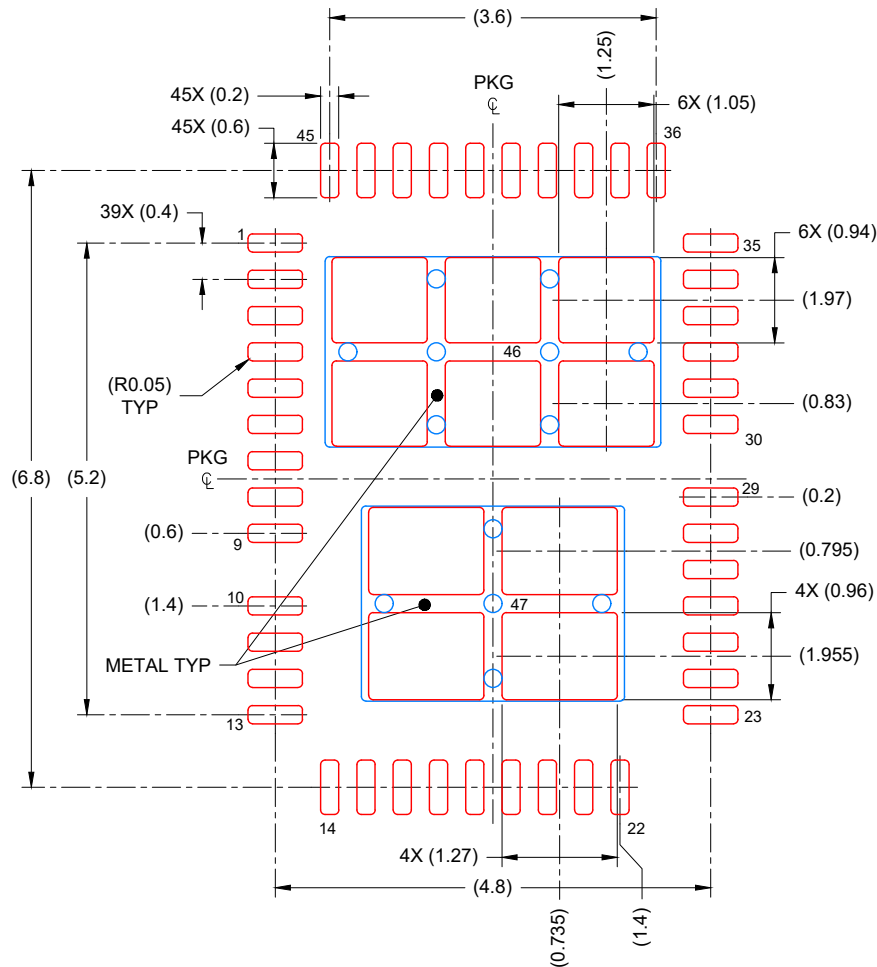

SOLDER PASTE EXAMPLE  
BASED ON 0.125 mm THICK STENCIL

PAD 46: 76%; PAD 47: 78%  
SCALE: 12X

4225180/A 08/2019

NOTES: (continued)

6. Laser cutting apertures with trapezoidal walls and rounded corners may offer better paste release. IPC-7525 may have alternate design recommendations.

## IMPORTANT NOTICE AND DISCLAIMER

TI PROVIDES TECHNICAL AND RELIABILITY DATA (INCLUDING DATA SHEETS), DESIGN RESOURCES (INCLUDING REFERENCE DESIGNS), APPLICATION OR OTHER DESIGN ADVICE, WEB TOOLS, SAFETY INFORMATION, AND OTHER RESOURCES "AS IS" AND WITH ALL FAULTS, AND DISCLAIMS ALL WARRANTIES, EXPRESS AND IMPLIED, INCLUDING WITHOUT LIMITATION ANY IMPLIED WARRANTIES OF MERCHANTABILITY, FITNESS FOR A PARTICULAR PURPOSE OR NON-INFRINGEMENT OF THIRD PARTY INTELLECTUAL PROPERTY RIGHTS.

These resources are intended for skilled developers designing with TI products. You are solely responsible for (1) selecting the appropriate TI products for your application, (2) designing, validating and testing your application, and (3) ensuring your application meets applicable standards, and any other safety, security, regulatory or other requirements.

These resources are subject to change without notice. TI grants you permission to use these resources only for development of an application that uses the TI products described in the resource. Other reproduction and display of these resources is prohibited. No license is granted to any other TI intellectual property right or to any third party intellectual property right. TI disclaims responsibility for, and you will fully indemnify TI and its representatives against, any claims, damages, costs, losses, and liabilities arising out of your use of these resources.

TI's products are provided subject to [TI's Terms of Sale](#) or other applicable terms available either on [ti.com](http://ti.com) or provided in conjunction with such TI products. TI's provision of these resources does not expand or otherwise alter TI's applicable warranties or warranty disclaimers for TI products.

TI objects to and rejects any additional or different terms you may have proposed.

Mailing Address: Texas Instruments, Post Office Box 655303, Dallas, Texas 75265  
Copyright © 2022, Texas Instruments Incorporated