

## High-Performance, Single Synchronous Step-Down Controller For Notebook Power Supply

### FEATURES

- **Wide Input Voltage Range: 3 V to 28 V**
- **Output Voltage Range: 0.7 V to 2.6 V**
- **Wide Output Load Range: 0 to 20A+**
- **Built-in 0.5% 0.7 V Reference**
- **290-kHz, Adaptive On-Time D-CAP™ MODE Control**
- **4700 ppm/°C  $R_{DS(on)}$  Current Sensing**
- **Internal 1-ms Voltage Servo Soft-start**
- **Pre-Charged Start-up Capability**
- **Built in Output Discharge**
- **Power Good Output**
- **Integrated Boost Switch**
- **Built-in OVP/UVP/OCV**
- **Thermal Shutdown (Non-latch)**
- **SON-10 (DSC) Package**

### APPLICATIONS

- **Notebook Computers**
- **I/O Supplies**
- **System Power Supplies**

### DESCRIPTION

The TPS51211 is a small-sized single buck controller with adaptive on-time D-CAP™ mode. The device is suitable for low output voltage, high current, PC system power rail and similar point-of-load (POL) power supply in digital consumer products. A small package with minimal pin-count saves space on the PCB, while a dedicated EN pin and pre-set frequency minimize design effort required for new designs. The skip-mode at light load condition, strong gate drivers and low-side FET  $R_{DS(on)}$  current sensing supports low-loss and high efficiency, over a broad load range. The conversion input voltage which is the high-side FET drain voltage ranges from 3 V to 28 V and the output voltage ranges from 0.7 V to 2.6 V. The device requires an external 5-V supply. The TPS51211 is available in a 10-pin SON package specified from –40°C to 85°C.

### TYPICAL APPLICATION CIRCUIT

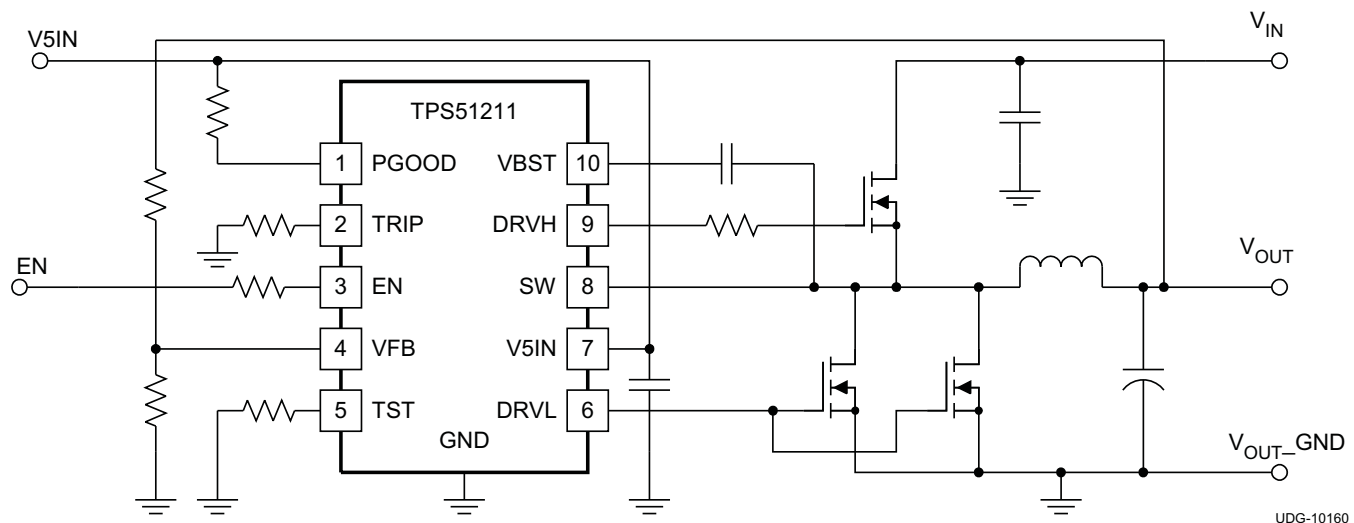

UDG-10160



Please be aware that an important notice concerning availability, standard warranty, and use in critical applications of Texas Instruments semiconductor products and disclaimers thereto appears at the end of this data sheet.

D-CAP is a trademark of Texas Instruments.

PRODUCTION DATA information is current as of publication date. Products conform to specifications per the terms of the Texas Instruments standard warranty. Production processing does not necessarily include testing of all parameters.

Copyright © 2010–2013, Texas Instruments Incorporated



This integrated circuit can be damaged by ESD. Texas Instruments recommends that all integrated circuits be handled with appropriate precautions. Failure to observe proper handling and installation procedures can cause damage.

ESD damage can range from subtle performance degradation to complete device failure. Precision integrated circuits may be more susceptible to damage because very small parametric changes could cause the device not to meet its published specifications.

### ORDERING INFORMATION

T <sub>A</sub>	PACKAGE	ORDERING DEVICE NUMBER	PINS	OUTPUT SUPPLY	MINIMUM QUANTITY
-40°C to 85°C	Plastic SON PowerPAD	TPS51211DSCR	10	Tape and reel	3000
		TPS51211DSCT	10	Mini reel	250

### ABSOLUTE MAXIMUM RATINGS<sup>(1)</sup>

over operating free-air temperature range (unless otherwise noted)

		VALUE	UNIT
Input voltage range <sup>(2)</sup>	VBST	-0.3 to 37	V
	VBST <sup>(3)</sup>	-0.3 to 7	
	SW	-5 to 30	
	V5IN, EN, TRIP, VFB, TST	-0.3 to 7	
Output voltage range <sup>(2)</sup>	DRVH	-5 to 37	V
	DRVH <sup>(3)</sup>	-0.3 to 7	
	DRVH <sup>(3)</sup> , pulse width < 20 ns	-2.5 to 7	
	DRVL	-0.5 to 7	
	DRVL, pulse width < 20 ns	-2.5 to 7	
	PGOOD	-0.3 to 7	
T <sub>J</sub>	Junction temperature range	150	°C
T <sub>STG</sub>	Storage temperature range	-55 to 150	°C

- (1) Stresses beyond those listed under *absolute maximum ratings* may cause permanent damage to the device. These are stress ratings only and functional operation of the device at these or any other conditions beyond those indicated under *recommended operating conditions* is not implied. Exposure to absolute-maximum-rated conditions for extended periods may affect device reliability.
- (2) All voltage values are with respect to the network ground terminal unless otherwise noted.
- (3) Voltage values are with respect to the SW terminal.

### DISSIPATION RATINGS

2-oz. trace and copper pad with solder.

PACKAGE	T <sub>A</sub> < 25°C POWER RATING	DERATING FACTOR ABOVE T <sub>A</sub> = 25°C	T <sub>A</sub> = 85°C POWER RATING
10-pin DSC <sup>(1)</sup>	1.54 W	15 mW/°C	0.62 W

- (1) Enhanced thermal conductance by thermal vias is used beneath thermal pad as shown in Land Pattern information.

## RECOMMENDED OPERATING CONDITIONS

over operating free-air temperature range (unless otherwise noted)

		MIN	TYP	MAX	UNIT
Supply voltage	V5IN	4.5		6.5	V
Input voltage range	VBST	-0.1		34.5	V
	SW	-1		28	
	SW <sup>(1)</sup>	-4		28	
	VBST <sup>(2)</sup>	-0.1		6.5	
	EN, TRIP, VFB, TST	-0.1		6.5	
Output voltage range	DRVH	-1		34.5	V
	DRVH <sup>(1)</sup>	-4		34.5	
	DRVH <sup>(2)</sup>	-0.1		6.5	
	DRVL	-0.3		6.5	
	PGOOD	-0.1		6.5	
T <sub>A</sub>	Operating free-air temperature	-40		85	°C

(1) This voltage should be applied for less than 30% of the repetitive period.

(2) Voltage values are with respect to the SW terminal.

## ELECTRICAL CHARACTERISTICS

over recommended free-air temperature range,  $V_{V5IN} = 5\text{ V}$ . (Unless otherwise noted)

PARAMETER		TEST CONDITIONS	MIN	TYP	MAX	UNIT
<b>SUPPLY CURRENT</b>						
$I_{V5IN}$	V5IN supply current	$T_A = 25^\circ\text{C}$ , No Load, $V_{EN} = 5\text{ V}$ , $V_{VFB} = 0.735\text{ V}$		320	600	$\mu\text{A}$
$I_{V5INSDN}$	V5IN shutdown current	$T_A = 25^\circ\text{C}$ , No Load, $V_{EN} = 0\text{ V}$			1	$\mu\text{A}$
<b>INTERNAL REFERENCE VOLTAGE</b>						
$V_{VFB}$	VFB regulation voltage	$T_A = 25^\circ\text{C}$	0.7005	0.7040	0.7075	V
		$-10^\circ\text{C} \leq T_A \leq 85^\circ\text{C}$	0.697	0.704	0.711	
$I_{VFB}$	VFB input current	$V_{VFB} = 0.735\text{ V}$ , $T_A = 25^\circ\text{C}$		0.01	0.2	$\mu\text{A}$
<b>OUTPUT DISCHARGE</b>						
$I_{Dischg}$	Output discharge current from SW pin	$V_{EN} = 0\text{ V}$ , $V_{SW} = 0.5\text{ V}$	5	13		mA
<b>OUTPUT DRIVERS</b>						
$R_{DRVH}$	DRVH resistance	Source, $I_{DRVH} = -50\text{ mA}$		1.5	3.6	$\Omega$
		Sink, $I_{DRVH} = 50\text{ mA}$		0.7	2.0	
$R_{DRVL}$	DRVL resistance	Source, $I_{DRVL} = -50\text{ mA}$		1.0	3.0	
		Sink, $I_{DRVL} = 50\text{ mA}$		0.5	1.6	
$t_D$	Dead time	DRVH-off to DRVL-on	7	17		ns
		DRVL-off to DRVH-on	10	22		
<b>BOOT STRAP SWITCH</b>						
$V_{FBST}$	Forward voltage	$V_{V5IN-VBST}$ , $I_F = 10\text{ mA}$ , $T_A = 25^\circ\text{C}$		0.1	0.2	V
$I_{VBSTLK}$	VBST leakage current	$V_{VBST} = 34.5\text{ V}$ , $V_{SW} = 28\text{ V}$ , $T_A = 25^\circ\text{C}$		0.01	1.5	$\mu\text{A}$
<b>DUTY AND FREQUENCY CONTROL</b>						
$t_{OFF(min)}$	Minimum off-time	$T_A = 25^\circ\text{C}$	150	260	400	ns
$t_{ON(min)}$	Minimum on-time	$V_{IN} = 28\text{ V}$ , $V_{OUT} = 0.7\text{ V}$ , $T_A = 25^\circ\text{C}^{(1)}$		79		
<b>SOFTSTART</b>						
$t_{SS}$	Internal SS time	From $V_{EN} = \text{high}$ to $V_{OUT} = 95\%$		1		ms
<b>POWERGOOD</b>						
$V_{THPG}$	PG threshold	PG in from lower	92.5%	95%	97.5%	
		PG in from higher	107.5%	110%	112.5%	
		PG hysteresis	2.5%	5%	7.5%	
$I_{PGMAX}$	PG sink current	$V_{PGOOD} = 0.5\text{ V}$	3	6		mA
$t_{PGDEL}$	PG delay	Delay for PG in	0.8	1	1.2	ms
<b>LOGIC THRESHOLD AND SETTING CONDITIONS</b>						
$V_{EN}$	EN voltage threshold	Enable	1.8			V
		Disable			0.5	
$I_{EN}$	EN input current	$V_{EN} = 5\text{ V}$			1.0	$\mu\text{A}$
$f_{SW}$	Switching frequency	$T_A = 25^\circ\text{C}^{(2)}$	266	290	314	kHz

(1) Ensured by design. Not production tested.

(2) Not production tested. Test condition is  $V_{IN} = 8\text{ V}$ ,  $V_{OUT} = 1.1\text{ V}$ ,  $I_{OUT} = 10\text{ A}$  using application circuit shown in [Figure 19](#).

**ELECTRICAL CHARACTERISTICS (continued)**

 over recommended free-air temperature range,  $V_{V5IN} = 5\text{ V}$ . (Unless otherwise noted)

PARAMETER		TEST CONDITIONS	MIN	TYP	MAX	UNIT
<b>PROTECTION: CURRENT SENSE</b>						
$I_{TRIP}$	TRIP source current	$V_{TRIP} = 1\text{ V}$ , $T_A = 25^\circ\text{C}$	9	10	11	$\mu\text{A}$
$T_{CITRIP}$	TRIP current temperature coefficient	On the basis of $25^\circ\text{C}$ <sup>(3)</sup>		4700		ppm/ $^\circ\text{C}$
$V_{TRIP}$	Current limit threshold setting range	$V_{TRIP-GND}$ Voltage	0.2		3	V
$V_{OCL}$	Current limit threshold	$V_{TRIP} = 3.0\text{ V}$		375		mV
		$V_{TRIP} = 0.2\text{ V}$		25		
$V_{AZCADJ}$	Adaptive zero cross adjustable range	Positive	3	15		mV
		Negative		-15	-3	
<b>PROTECTION: UVP AND OVP</b>						
$V_{OVP}$	OVP trip threshold	OVP detect	115%	120%	125%	
$t_{OVPDEL}$	OVP propagation delay time	50-mV overdrive		1		$\mu\text{s}$
$V_{UVP}$	Output UVP trip threshold	UVP detect	65%	70%	75%	
$t_{UVPDEL}$	Output UVP propagation delay time		0.8	1	1.2	ms
$t_{UVPEN}$	Output UVP enable delay time	From Enable to UVP workable	1.0	1.2	1.4	ms
<b>UVLO</b>						
$V_{UVV5IN}$	V5IN UVLO threshold	Wake up	4.20	4.38	4.50	V
		Shutdown	3.7	3.93	4.1	
<b>THERMAL SHUTDOWN</b>						
$T_{SDN}$	Thermal shutdown threshold	Shutdown temperature <sup>(3)</sup>		145		$^\circ\text{C}$
		Hysteresis <sup>(3)</sup>		10		

(3) Ensured by design. Not production tested.

## DEVICE INFORMATION

**DSC PACKAGE  
(TOP VIEW)**

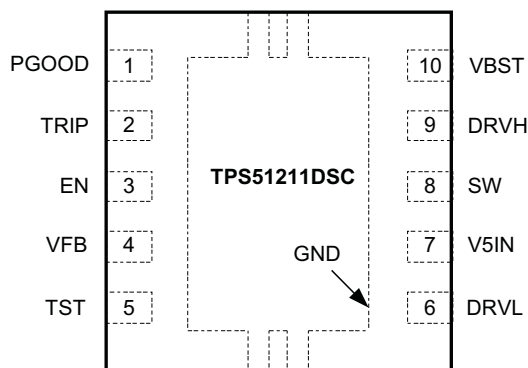

Thermal pad is used as an active terminal of GND.

## PIN FUNCTIONS

PIN		I/O	DESCRIPTION
NAME	NO.		
DRVH	9	O	High-side MOSFET driver output. The SW node referenced floating driver. The gate drive voltage is defined by the voltage across VBST to SW node bootstrap flying capacitor
DRVL	6	O	Synchronous MOSFET driver output. The GND referenced driver. The gate drive voltage is defined by V5IN voltage.
EN	3	I	SMPS enable pin. Short to GND to disable the device.
GND	Thermal Pad	I	Ground
PGOOD	1	O	Power Good window comparator open drain output. Pull up with resistor to 5 V or appropriate signal voltage. Continuous current capability is 1 mA. PGOOD goes high 1 ms after VFB becomes within specified limits. Power bad, or the terminal goes low, after a 2- $\mu$ s delay.
SW	8	I	Switch node. A high-side MOSFET gate drive return. Also used for on time generation and output discharge.
TRIP	2	I	OCL detection threshold setting pin. 10 $\mu$ A at room temperature, 4700 ppm/ $^{\circ}$ C current is sourced and set the OCL trip voltage as follows. $V_{OCL} = \frac{V_{TRIP}}{8} \quad (0.2 \text{ V} \leq V_{TRIP} \leq 3 \text{ V})$
TST	5	I	Used for testing purpose in production line. Pull down to GND with a resistor of 470 k $\Omega$ or less.
V5IN	7	I	5-V +30%/-10% power supply input.
VBST	10	I	Supply input for high-side MOSFET driver (bootstrap terminal). Connect a flying capacitor from this pin to the SW pin. Internally connected to V5IN via bootstrap MOSFET switch.
VFB	4	I	SMPS feedback input. Connect the feedback resistor divider.

FUNCTIONAL BLOCK DIAGRAM

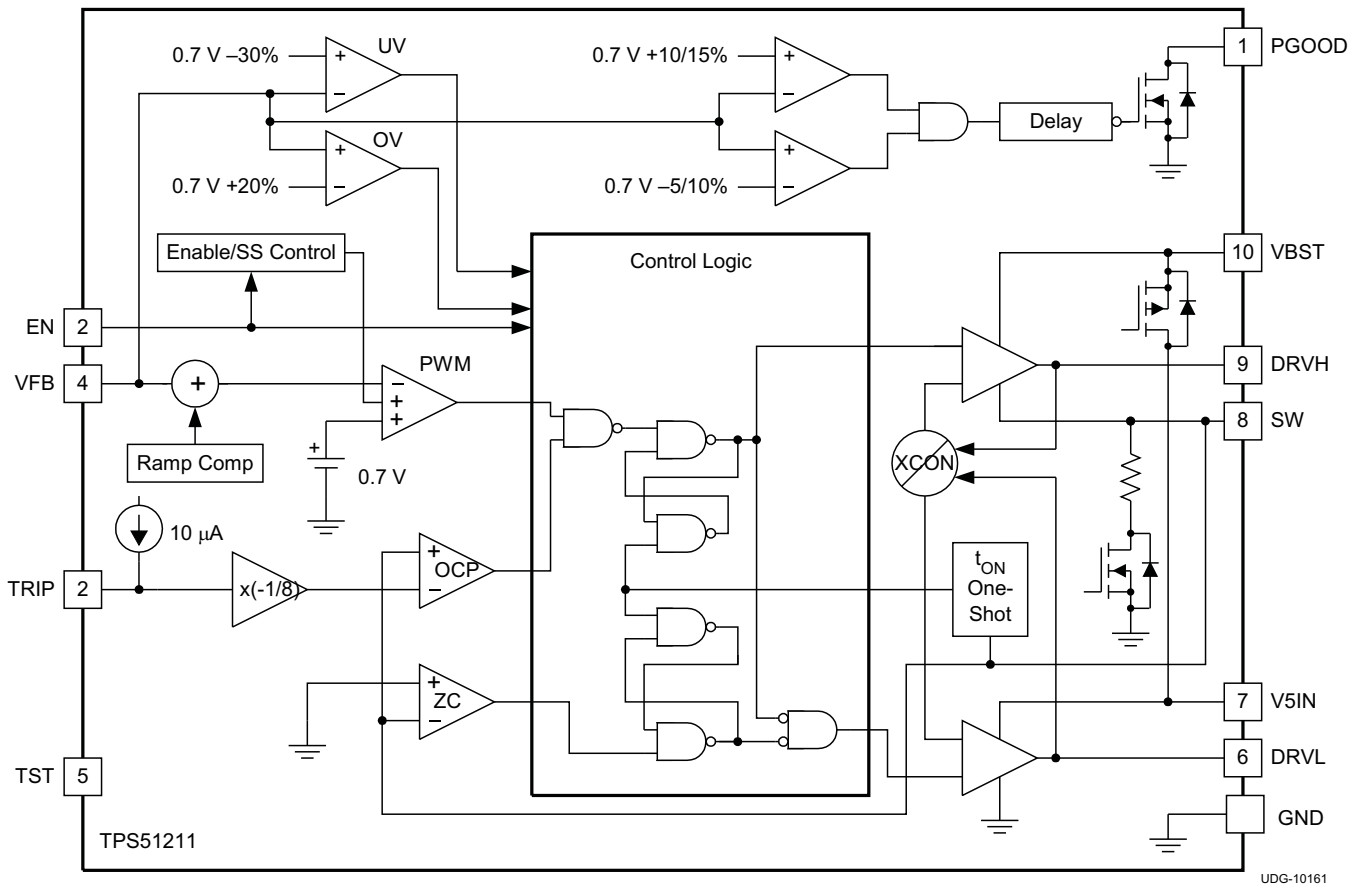

UDG-10161

TYPICAL CHARACTERISTICS

V5IN SUPPLY CURRENT  
VS  
JUNCTION TEMPERATURE

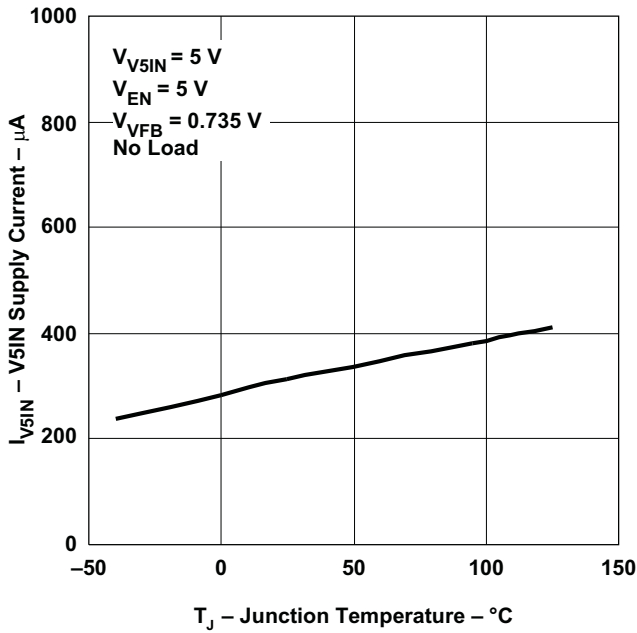

Figure 1.

V5IN SHUTDOWN CURRENT  
VS  
JUNCTION TEMPERATURE

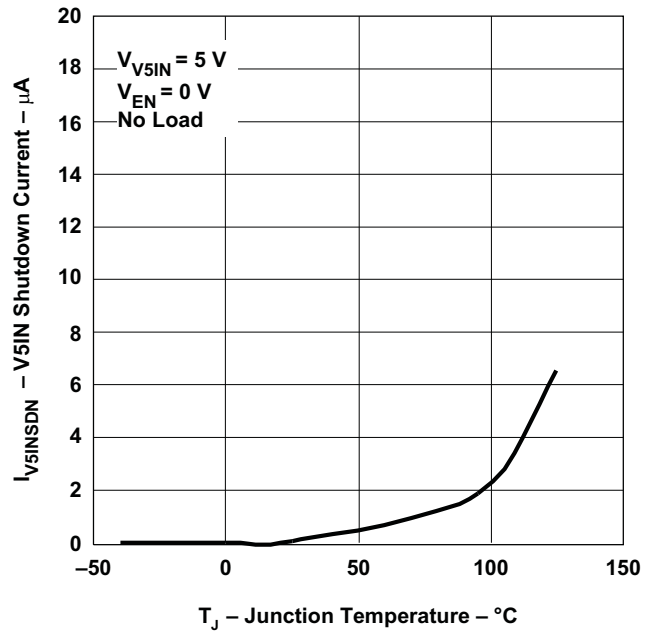

Figure 2.

OVP/UVP THRESHOLD  
VS  
JUNCTION TEMPERATURE

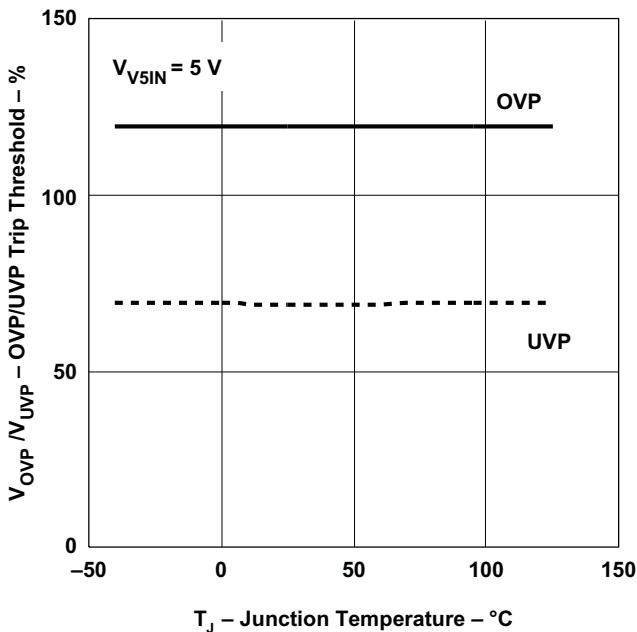

Figure 3.

CURRENT SENSE CURRENT (I\_TRIP)  
VS  
JUNCTION TEMPERATURE

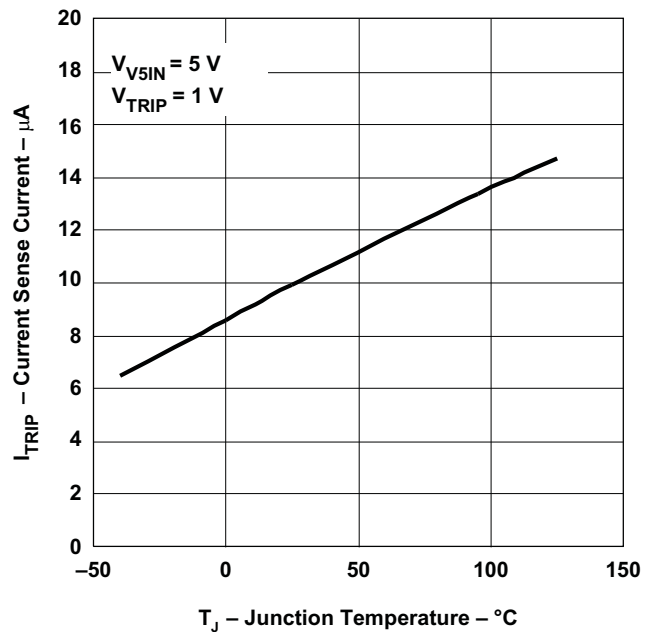
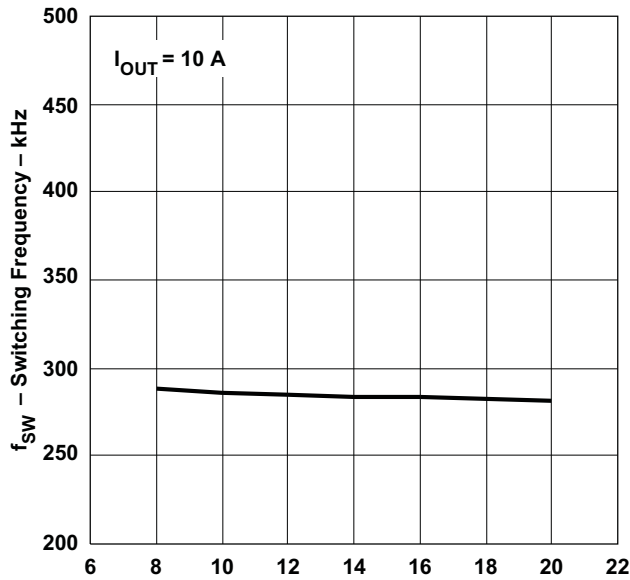

Figure 4.



TYPICAL CHARACTERISTICS (continued)

SWITCHING FREQUENCY  
VS  
INPUT VOLTAGE



$V_{IN}$  – Input Voltage – V  
Figure 5.

SWITCHING FREQUENCY  
VS  
OUTPUT CURRENT

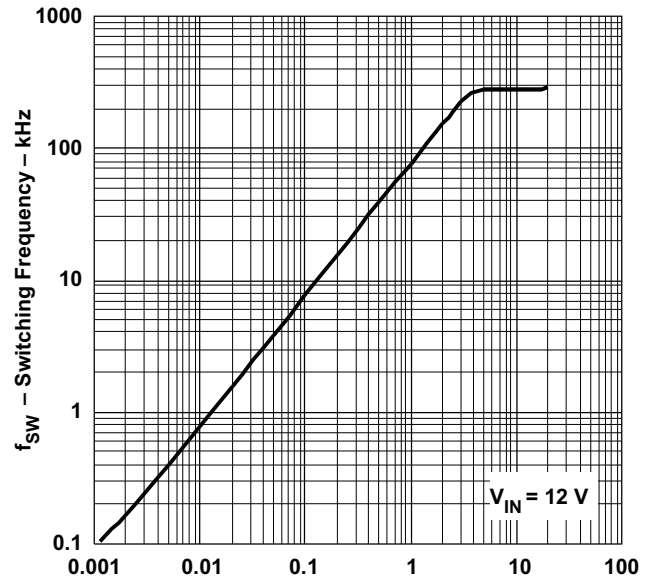

$I_{OUT}$  – Output Current – A  
Figure 6.

OUTPUT VOLTAGE  
VS  
OUTPUT CURRENT

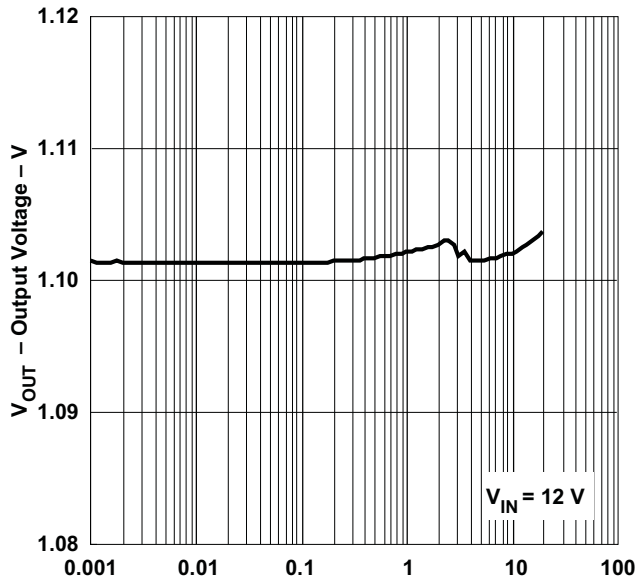

$I_{OUT}$  – Output Current – A  
Figure 7.

OUTPUT VOLTAGE  
VS  
INPUT VOLTAGE

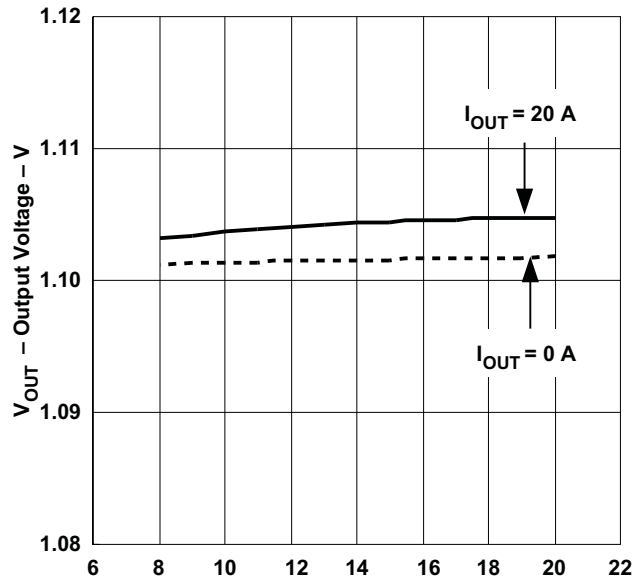

$V_{IN}$  – Input Voltage – V  
Figure 8.

TYPICAL CHARACTERISTICS (continued)

1.1-V EFFICIENCY  
VS  
OUTPUT CURRENT

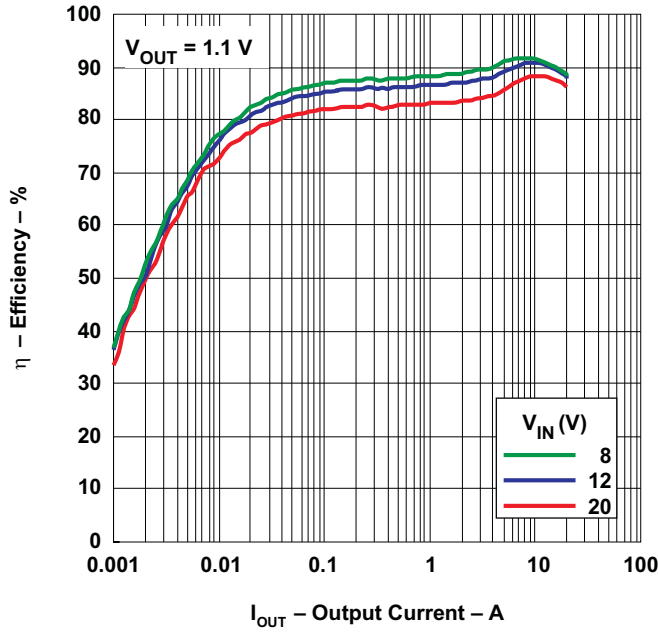

Figure 9.

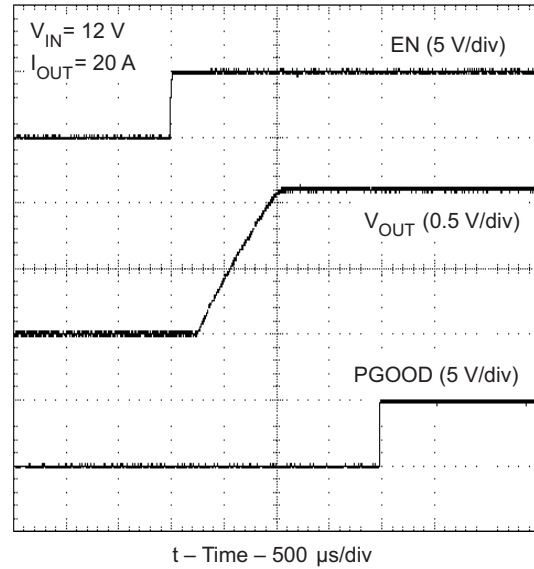

Figure 10. 1.1-V Start-Up Waveform

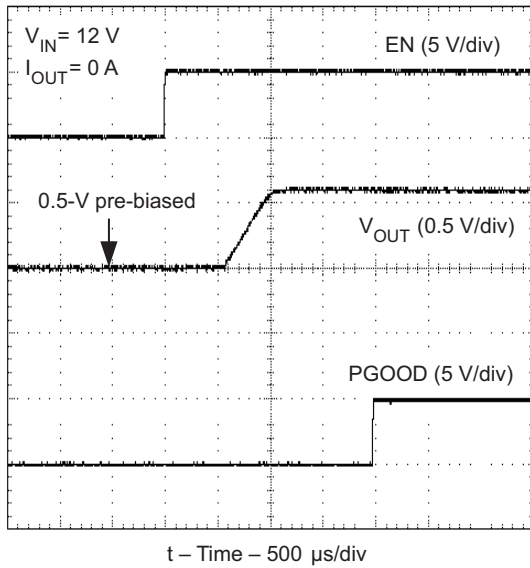

Figure 11. Pre-Biased Start-Up Waveform

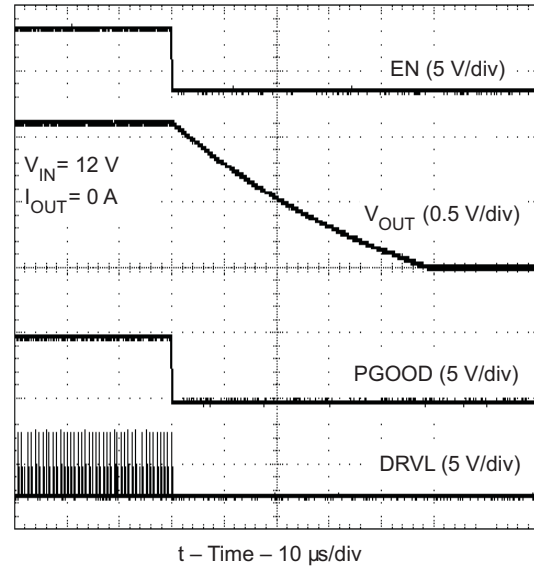
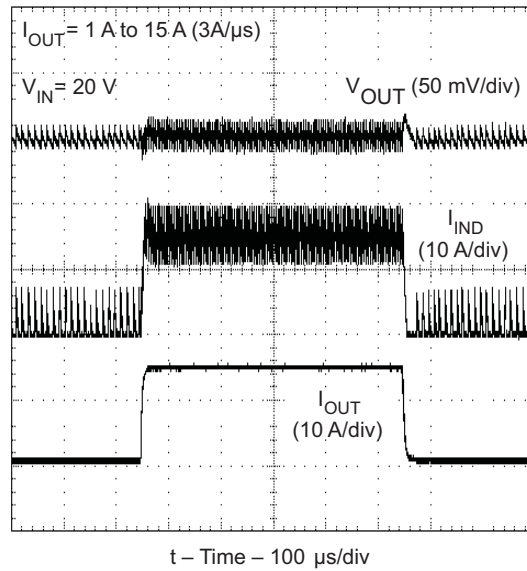

Figure 12. 1.1-V Soft-Stop Waveform

**TYPICAL CHARACTERISTICS (continued)**



**Figure 13. 1.1-V Load Transient Response**

## APPLICATION INFORMATION

### GENERAL DESCRIPTION

The TPS51211 is a high-efficiency, single channel, synchronous buck regulator controller suitable for low output voltage point-of-load applications in notebook computers and similar digital consumer applications. The device features proprietary D-CAP™ mode control combined with adaptive on-time architecture. This combination is ideal for building modern low duty ratio, ultra-fast load step response DC-DC converters. The output voltage ranges from 0.7 V to 2.6 V. The conversion input voltage range is from 3 V to 28 V. The D-CAP™ mode uses the ESR of the output capacitor(s) to sense current information. An advantage of this control scheme is that it does not require an external phase compensation network, helping the designer with ease-of-use and realizing low external component count configuration. Adaptive on-time control tracks the preset switching frequency over a wide range of input and output voltages, while it increases the switching frequency at step-up of load.

The strong gate drivers of the TPS51211 allow low  $R_{DS(on)}$  FETs for high-current applications.

### ENABLE AND SOFT START

When the EN pin voltage rises above the enable threshold, (typically 1.2 V) the controller enters its start-up sequence. An internal DAC begins to ramp up the reference voltage from 0 V to 0.7 V. This ramping time is 750  $\mu$ s. Smooth and constant ramp up of the output voltage is maintained during start up regardless of load current. Connect a 1-k $\Omega$  resistor in series with the EN pin to provide protection.

### ADAPTIVE ON-TIME D-CAP™ CONTROL

TPS51211 does not have a dedicated oscillator that determines switching frequency. However, the device runs with pseudo-constant frequency by feed-forwarding the input and output voltages into its on-time one-shot timer. The adaptive on-time control adjusts the on-time to be inversely proportional to the input voltage and proportional to the output voltage ( $t_{ON} \propto V_{OUT} / V_{IN}$ ). This makes the switching frequency fairly constant in steady state conditions over wide input voltage range.

The off-time is modulated by a PWM comparator. The VFB node voltage (the mid point of resistor divider) is compared to the internal 0.7-V reference voltage added with a ramp signal. When both signals match, the PWM comparator asserts the *set* signal to terminate the off-time (turn off the low-side MOSFET and turn on high-side MOSFET). The *set* signal becomes valid if the inductor current level is below OCP threshold, otherwise the off-time is extended until the current level to become below the threshold.

## SMALL SIGNAL MODEL

From small-signal loop analysis, a buck converter using D-CAP™ mode can be simplified as shown in Figure 14.

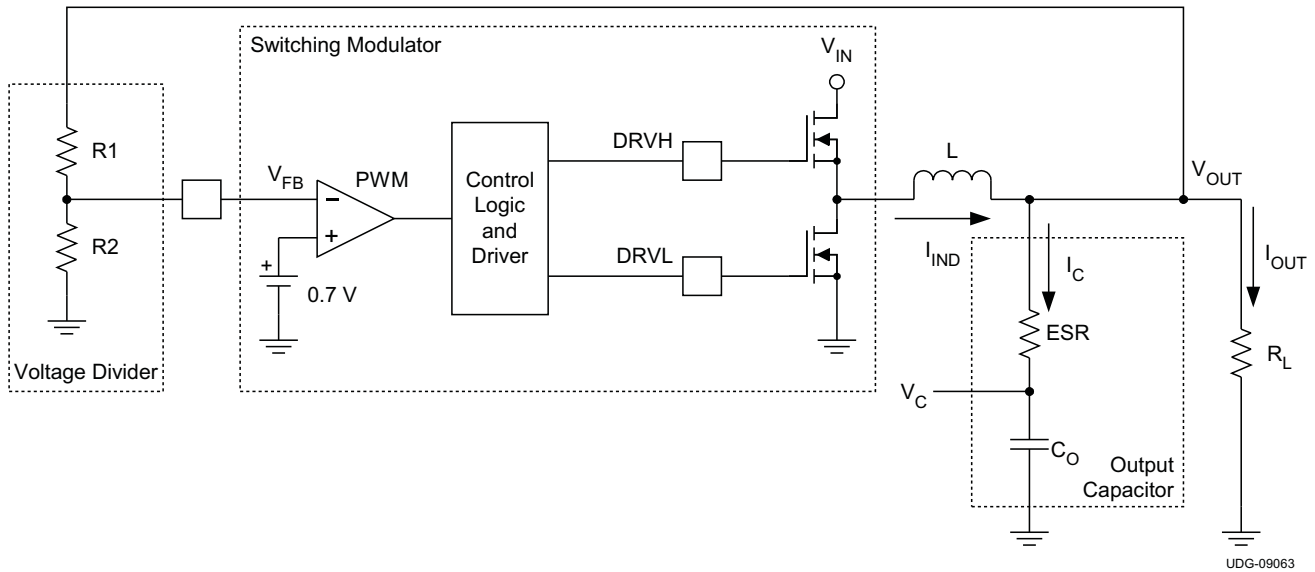

Figure 14. Simplified Modulator Model

The output voltage is compared with internal reference voltage (ramp signal is ignored here for simplicity). The PWM comparator determines the timing to turn on the high-side MOSFET. The gain and speed of the comparator can be assumed high enough to keep the voltage at the beginning of each on cycle substantially constant.

$$H(s) = \frac{1}{s \times \text{ESR} \times C_O} \quad (1)$$

For loop stability, the 0-dB frequency,  $f_0$ , defined in Equation 2 need to be lower than 1/4 of the switching frequency.

$$f_0 = \frac{1}{2\pi \times \text{ESR} \times C_O} \leq \frac{f_{\text{SW}}}{4} \quad (2)$$

According to Equation 2, the loop stability of D-CAP™ mode modulator is mainly determined by the capacitor's chemistry. For example, specialty polymer capacitors (SP-CAP) have  $C_O$  on the order of several 100  $\mu\text{F}$  and ESR in range of 10 m $\Omega$ . These makes  $f_0$  on the order of 100 kHz or less and the loop is stable. However, ceramic capacitors have an  $f_0$  of more than 700 kHz, which is not suitable for this modulator.

## RAMP SIGNAL

The TPS51211 adds a ramp signal to the 0.7-V reference in order to improve its jitter performance. As described in the previous section, the feedback voltage is compared with the reference information to keep the output voltage in regulation. By adding a small ramp signal to the reference, the S/N ratio at the onset of a new switching cycle is improved. Therefore the operation becomes less jittery and more stable. The ramp signal is controlled to start with  $-7$  mV at the beginning of ON-cycle and becomes 0 mV at the end of OFF-cycle in continuous conduction steady state.

## LIGHT LOAD CONDITION IN AUTO-SKIP OPERATION

The TPS51211 automatically reduces switching frequency at light load conditions to maintain high efficiency. As the output current decreases from heavy load condition, the inductor current is also reduced and eventually comes to the point that its rippled *valley* touches zero level, which is the boundary between continuous conduction and discontinuous conduction modes. The rectifying MOSFET is turned off when this zero inductor current is detected. As the load current further decreases, the converter runs in to discontinuous conduction mode. The on-time is kept almost the same as it was in the continuous conduction mode so that it takes longer time to discharge the output capacitor with smaller load current to the level of the reference voltage. The transition point to the light load operation  $I_{O(LL)}$  (i.e., the threshold between continuous and discontinuous conduction mode) can be calculated in [Equation 3](#).

$$I_{O(LL)} = \frac{1}{2 \times L \times f_{SW}} \times \frac{(V_{IN} - V_{OUT}) \times V_{OUT}}{V_{IN}}$$

where

- $f_{SW}$  is the PWM switching frequency (3)

Switching frequency versus output current in the light load condition is a function of  $L$ ,  $V_{IN}$  and  $V_{OUT}$ , but it decreases almost proportional to the output current from the  $I_{O(LL)}$  given in [Equation 3](#). For example, it is 58 kHz at  $I_{O(LL)}/5$  if the frequency setting is 290 kHz.

## ADAPTIVE ZERO CROSSING

The TPS51211 has an adaptive zero crossing circuit which performs optimization of the zero inductor current detection at skip mode operation. This function pursues ideal low-side MOSFET turning off timing and compensates inherent offset voltage of the ZC comparator and delay time of the ZC detection circuit. It prevents SW-node swing-up caused by too late detection and minimizes diode conduction period caused by too early detection. As a result, better light load efficiency is delivered.

## OUTPUT DISCHARGE CONTROL

When EN is low, the TPS51211 discharges the output capacitor using internal MOSFET connected between SW and GND while high-side and low-side MOSFETs are kept off. The current capability of this MOSFET is limited to discharge slowly.

## LOW-SIDE DRIVER

The low-side driver is designed to drive high current low  $R_{DS(on)}$  N-channel MOSFET(s). The drive capability is represented by its internal resistance, which are  $1.0\Omega$  for V5IN to DRVL and  $0.5\Omega$  for DRVL to GND. A dead time to prevent shoot through is internally generated between high-side MOSFET off to low-side MOSFET on, and low-side MOSFET off to high-side MOSFET on. 5-V bias voltage is delivered from V5IN supply. The instantaneous drive current is supplied by an input capacitor connected between V5IN and GND. The average drive current is equal to the gate charge at  $V_{GS}=5V$  times switching frequency. This gate drive current as well as the high-side gate drive current times 5V makes the driving power which need to be dissipated from TPS51211 package.

## HIGH-SIDE DRIVER

The high-side driver is designed to drive high current, low  $R_{DS(on)}$  N-channel MOSFET(s). When configured as a floating driver, 5 V of bias voltage is delivered from V5IN supply. The average drive current is also equal to the gate charge at  $V_{GS}=5V$  times switching frequency. The instantaneous drive current is supplied by the flying capacitor between VBST and SW pins. The drive capability is represented by its internal resistance, which are  $1.5\Omega$  for VBST to DRVH and  $0.7\Omega$  for DRVH to SW.

## POWER-GOOD

The TPS51211 has powergood output that indicates high when switcher output is within the target. The powergood function is activated after soft-start has finished. If the output voltage becomes within +10%/–5% of the target value, internal comparators detect power-good state and the power-good signal becomes high after a 1-ms internal delay. If the output voltage goes outside of +15%/–10% of the target value, the powergood signal becomes low after a 2-μs internal delay. The powergood output is an open-drain output and must be pulled up externally.

## CURRENT SENSE AND OVER CURRENT PROTECTION

TPS51211 has cycle-by-cycle overcurrent limiting control. The inductor current is monitored during the OFF state and the controller keeps the OFF state during the inductor current is larger than the overcurrent trip level. To provide both good accuracy and cost effective solution, the TPS51211 supports temperature compensated MOSFET  $R_{DS(on)}$  sensing. The TRIP pin should be connected to GND through the trip voltage setting resistor,  $R_{TRIP}$ . The TRIP terminal sources  $I_{TRIP}$  current, which is 10μA typically at room temperature, and the trip level is set to the OCL trip voltage  $V_{TRIP}$  as shown in Equation 4. Note that  $V_{TRIP}$  is limited up to approximately 3 V internally.

$$V_{TRIP}(mV) = R_{TRIP}(k\Omega) \times I_{TRIP}(\mu A) \quad (4)$$

The inductor current is monitored by the voltage between GND pad and SW pin so that the SW pin should be connected to the drain terminal of the low-side MOSFET properly.  $I_{TRIP}$  has 4700ppm/°C temperature slope to compensate the temperature dependency of the  $R_{DS(on)}$ . GND is used as the positive current sensing node so that GND should be connected to the proper current sensing device, i.e. the source terminal of the low-side MOSFET.

As the comparison is done during the OFF state,  $V_{TRIP}$  sets valley level of the inductor current. Thus, the load current at overcurrent threshold,  $I_{OCP}$ , can be calculated in Equation 5

$$I_{OCP} = \left( \frac{V_{TRIP}}{8 \times R_{DS(on)}} \right) + \frac{I_{IND(ripple)}}{2} = \frac{V_{TRIP}}{8 \times R_{DS(on)}} + \frac{1}{2 \times L \times f_{SW}} \times \frac{(V_{IN} - V_{OUT}) \times V_{OUT}}{V_{IN}} \quad (5)$$

In an overcurrent condition, the current to the load exceeds the current to the output capacitor thus the output voltage tends to fall down. Eventually, it crosses the undervoltage protection threshold and shuts down the controller.

## OVER/UNDER VOLTAGE PROTECTION

TPS51211 monitors a resistor divided feedback voltage to detect over and undervoltage. When the feedback voltage becomes higher than 120% of the target voltage, the OVP comparator output goes high and the circuit latches as the high-side MOSFET driver OFF and the low-side MOSFET driver ON.

When the feedback voltage becomes lower than 70% of the target voltage, the UVP comparator output goes high and an internal UVP delay counter begins counting. After a 1-ms delay, TPS51211 latches OFF both high-side and low-side MOSFETs drivers. This function is enabled after 1.2 ms following EN has become high.

## UVLO PROTECTION

TPS51211 has  $V_{5IN}$  undervoltage lockout protection (UVLO). When the  $V_{5IN}$  voltage is lower than UVLO threshold voltage, the switch mode power supply shuts off. This is non-latch protection.

## THERMAL SHUTDOWN

TPS51211 monitors the die temperature. If the temperature exceeds the threshold value (typically 145°C), the TPS51211 is shut off. This is non-latch protection.

## EXTERNAL COMPONENTS SELECTION

Selecting external components is simple in D-CAP™ mode.

### Step 1. Choose the inductor.

The inductance value should be determined to give the ripple current of approximately 1/4 to 1/2 of maximum output current. Larger ripple current increases output ripple voltage and improves S/N ratio and helps stable operation.

$$L = \frac{1}{I_{\text{IND(ripple)}} \times f_{\text{SW}}} \times \frac{(V_{\text{IN(max)}} - V_{\text{OUT}}) \times V_{\text{OUT}}}{V_{\text{IN(max)}}} = \frac{3}{I_{\text{OUT(max)}} \times f_{\text{SW}}} \times \frac{(V_{\text{IN(max)}} - V_{\text{OUT}}) \times V_{\text{OUT}}}{V_{\text{IN(max)}}} \quad (6)$$

The inductor also needs to have low DCR to achieve good efficiency, as well as enough room above peak inductor current before saturation. The peak inductor current can be estimated in [Equation 7](#).

$$I_{\text{IND(peak)}} = \frac{V_{\text{TRIP}}}{8 \times R_{\text{DS(on)}}} + \frac{1}{L \times f_{\text{SW}}} \times \frac{(V_{\text{IN(max)}} - V_{\text{OUT}}) \times V_{\text{OUT}}}{V_{\text{IN(max)}}} \quad (7)$$

### Step 2. Choose the output capacitor(s).

Organic semiconductor capacitor(s) or specialty polymer capacitor(s) are recommended. For loop stability, capacitance and ESR should satisfy [Equation 2](#). For jitter performance, [Equation 8](#) is a good starting point to determine ESR.

$$\text{ESR} = \frac{V_{\text{OUT}} \times 10 [\text{mV}] \times (1-D)}{0.7 [\text{V}] \times I_{\text{IND(ripple)}}} = \frac{10 [\text{mV}] \times L \times f_{\text{SW}}}{0.7 [\text{V}]} = \frac{L \times f_{\text{SW}}}{70} [\Omega]$$

where

- D is the duty ratio
- the output ripple down slope rate is 10 mV/ $t_{\text{SW}}$  in terms of VFB terminal voltage as shown in [Figure 15](#)
- $t_{\text{SW}}$  is the switching period

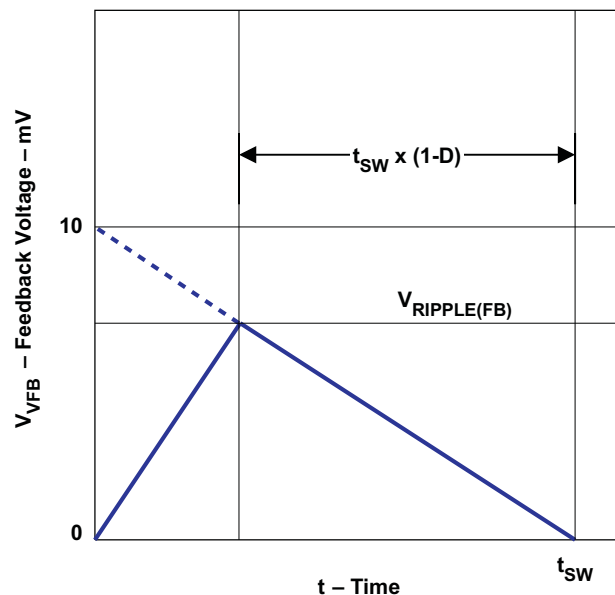

Figure 15. Ripple Voltage Down Slope



**Step 3. Determine the value of R1 and R2.**

The output voltage is programmed by the voltage-divider resistor, R1 and R2, shown in Figure 14. R1 is connected between the VFB pin and the output, and R2 is connected between the VFB pin and GND. Typical designs begin with the selection of an R2 value between 10 kΩ and 20 kΩ. Determine R1 using Equation 9.

$$R1 = \frac{\left( V_{OUT} - \frac{I_{IND(ripple)} \times ESR}{2} \right) - 0.7}{0.7} \times R2 \tag{9}$$

**Special consideration for high-side drivers.**

When an application uses the latest fast-switching type MOSFETs, it is recommended to populate the design with two resistors before evaluation (without shorting).

In this situation, place R7 in series with the bootstrap capacitor and place R8 in series with the high-side gate driver as shown in Figure 16. Both resistors can have a value of 0 Ω and they should be placed regardless of the design in case they are ultimately needed to control switching speed. When a resistance of 0 Ω is confirmed as a result of the evaluation, the resistor can be shorted in the final design.

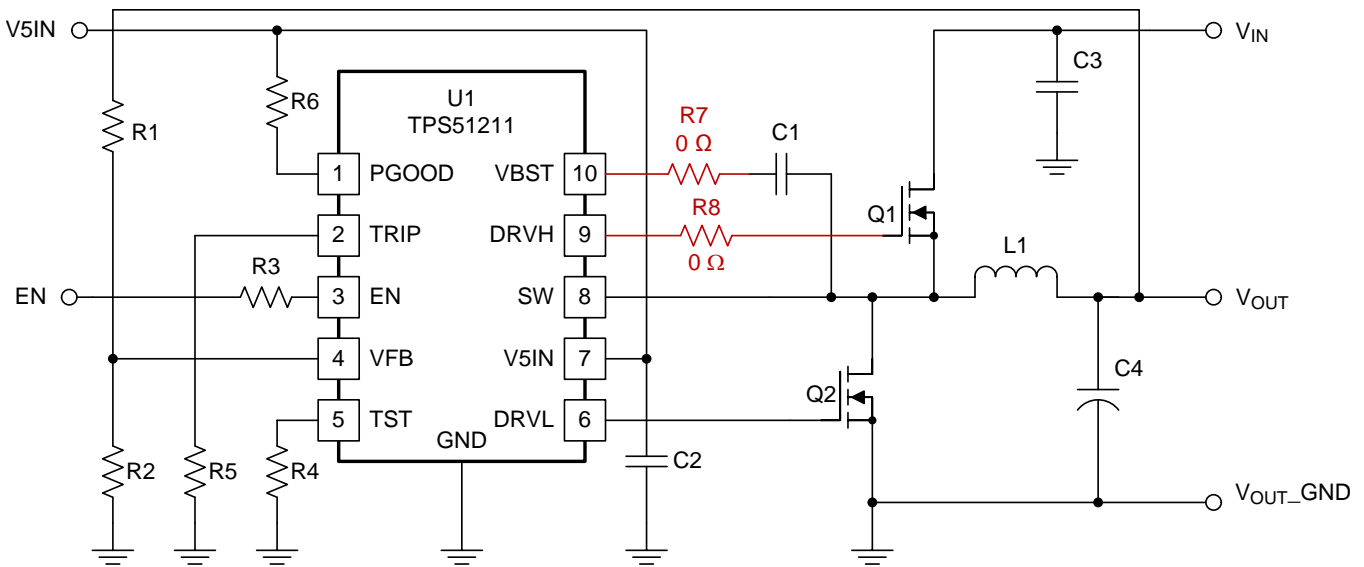

UDG-13107

**Figure 16. Special Consideration for High-Side Drivers**

## LAYOUT CONSIDERATIONS

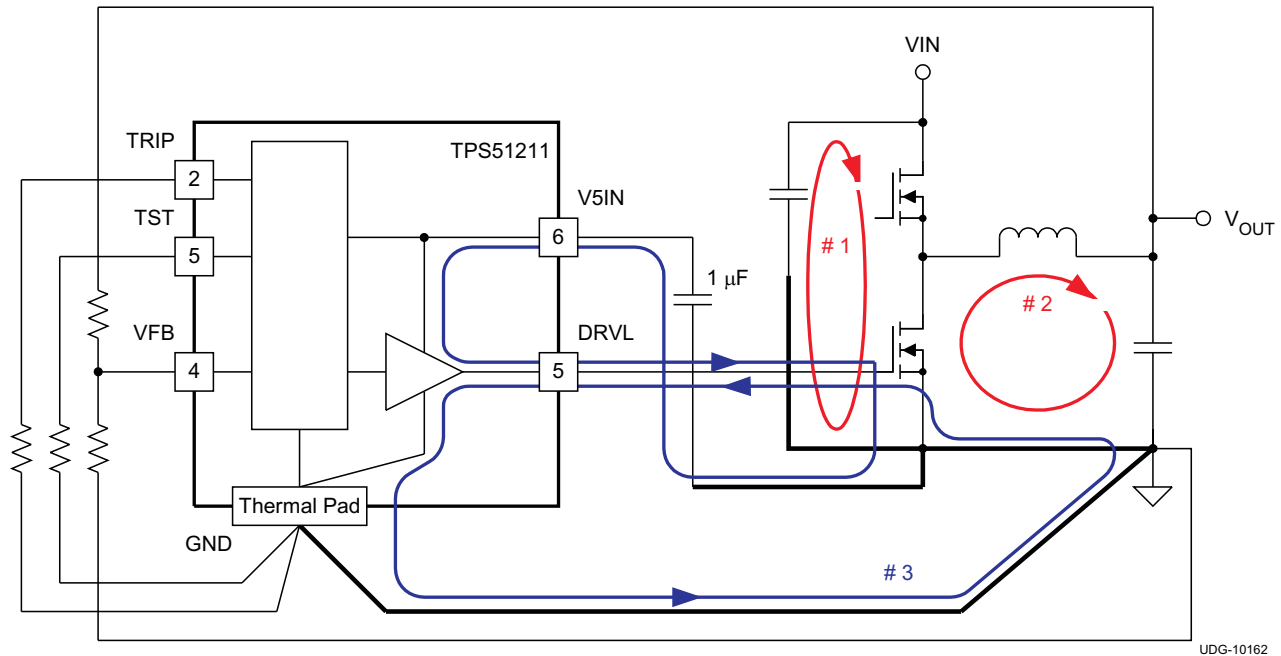

**Figure 17. Ground System of DC/DC Converter Using the TPS51211**

Certain points must be considered before starting a layout work using the TPS51211.

- Inductor,  $V_{IN}$  capacitor(s),  $V_{OUT}$  capacitor(s) and MOSFETs are the power components and should be placed on one side of the PCB (solder side). Other small signal components should be placed on another side (component side). At least one inner plane should be inserted, connected to ground, in order to shield and isolate the small signal traces from noisy power lines.
- All sensitive analog traces and components such as VFB, PGOOD, TRIP and TST should be placed away from high-voltage switching nodes such as SW, DRVH, DRV or VBST to avoid coupling. Use internal layer(s) as ground plane(s) and shield feedback trace from power traces and components.
- The DC/DC converter has several high-current loops. The area of these loops should be minimized in order to suppress generating switching noise.
  - The most important loop to minimize the area of is the path from the  $V_{IN}$  capacitor(s) through the high and low-side MOSFETs, and back to the capacitor(s) through ground. Connect the negative node of the  $V_{IN}$  capacitor(s) and the source of the low-side MOSFET at ground as close as possible. (Refer to loop #1 of [Figure 17](#))
  - The second important loop is the path from the low-side MOSFET through inductor and  $V_{OUT}$  capacitor(s), and back to source of the low-side MOSFET through ground. Connect source of the low-side MOSFET and negative node of  $V_{OUT}$  capacitor(s) at ground as close as possible. (Refer to loop #2 of [Figure 17](#))
  - The third important loop is of gate driving system for the low-side MOSFET. To turn on the low-side MOSFET, high current flows from  $V_{5IN}$  capacitor through gate driver and the low-side MOSFET, and back to negative node of the capacitor through ground. To turn off the low-side MOSFET, high current flows from gate of the low-side MOSFET through the gate driver and GND pad of the device, and back to source of the low-side MOSFET through ground. Connect negative node of  $V_{5IN}$  capacitor, source of the low-side MOSFET and GND pad of the device at ground as close as possible. (Refer to loop #3 of [Figure 17](#))
- Since the TPS51211 controls output voltage referring to voltage across  $V_{OUT}$  capacitor, the top-side resistor of the voltage divider should be connected to the positive node of  $V_{OUT}$  capacitor. In a same manner both bottom side resistor and GND pad of the device should be connected to the negative node of  $V_{OUT}$  capacitor. The trace from these resistors to the VFB pin should be short and thin. Place on the component side and avoid via(s) between these resistors and the device.
- Connect the overcurrent setting resistors from TRIP pin to ground and make the connections as close as possible to the device. The trace from TRIP pin to resistor and from resistor to ground should avoid coupling

to a high-voltage switching node.

- Connect the frequency setting resistor from TST pin to ground, or to the PGOOD pin, and make the connections as close as possible to the device. The trace from the TST pin to the resistor and from the resistor to ground should avoid coupling to a high-voltage switching node.
- Connections from gate drivers to the respective gate of the high-side or the low-side MOSFET should be as short as possible to reduce stray inductance. Use 0.65 mm (25 mils) or wider trace and via(s) of at least 0.5 mm (20 mils) diameter along this trace.
- The PCB trace defined as switch node, which connects to source of high-side MOSFET, drain of low-side MOSFET and high-voltage side of the inductor, should be as short and wide as possible.

## LAYOUT CONSIDERATIONS TO REMOTE SENSING

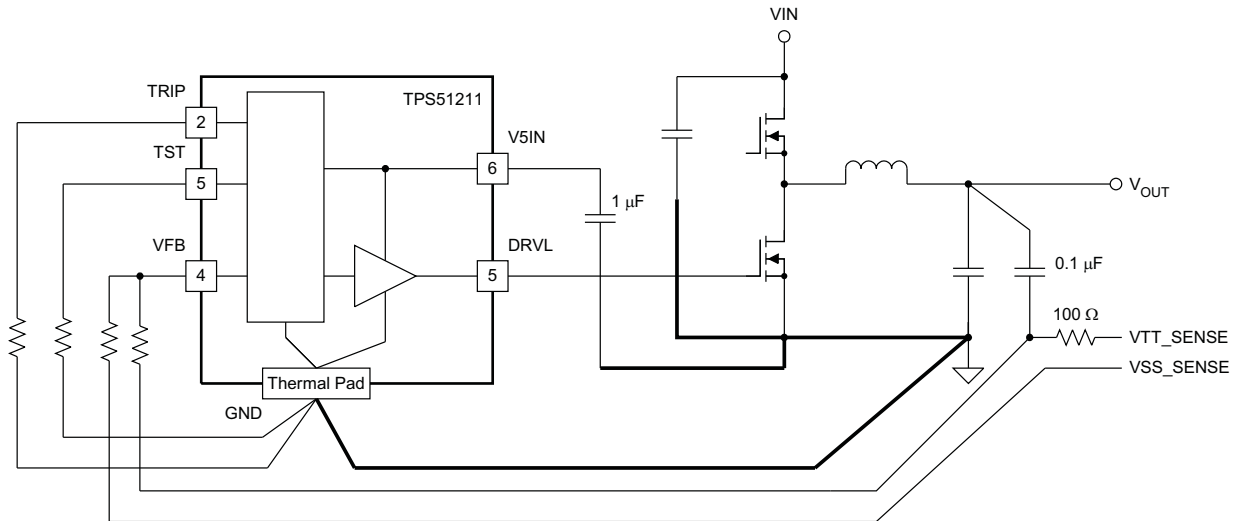

UDG-10163

**Figure 18. Remote Sensing of Output Voltage Using the TPS51211**

- Make a Kelvin connection to the load device.
- Run the feedback signals as a differential pair to the device. The distance of these parallel pair should be as short as possible.
- Run the lines in a quiet layer. Isolate them from noisy signals by a voltage or ground plane.

TPS51211 APPLICATION CIRCUITS

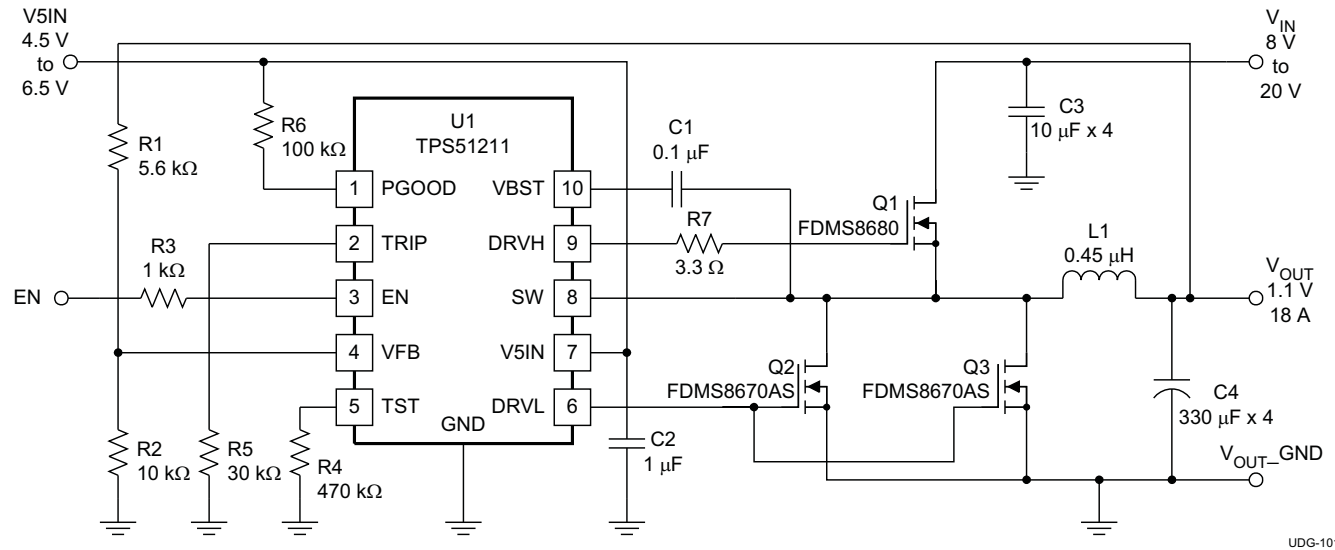

Figure 19. 1.1-V V<sub>OUT</sub>, 18-A I<sub>OUT</sub> Application

Table 1. 1.1-V, 18-A, 290-kHz Application List of Materials

REFERENCE DESIGNATOR	QTY	SPECIFICATION	MANUFACTURER	PART NUMBER
C3	1	4 × 10 μF, 25 V	Taiyo Yuden	TMK325BJ106MM
C4	1	4 × 330 μF, 2 V, 12 mΩ	Panasonic	EEFCX0D331XR
L1	1	0.45 μH, 25 A, 1.1 mΩ	Panasonic	ETQP4LR45XFC
Q1	1	30 V, 35 A, 8.5 mΩ	Fairchild	FDMS8680
Q2, Q3	2	30 V, 42 A, 3.5 mΩ	Fairchild	FDMS8670AS

---

**Changes from Original (NOVEMBER 2010) to Revision A** **Page**

- Added DRVH, pulse width < 20 ns rating in ABSOLUTE MAXIMUM RATINGS table ..... [2](#)
  - Added DRVL, pulse width < 20 ns rating in ABSOLUTE MAXIMUM RATINGS table ..... [2](#)
- 

**Changes from Revision A (FEBRUARY 2012) to Revision B** **Page**

- Added clarity to the [EXTERNAL COMPONENTS SELECTION](#) section ..... [16](#)
-

**PACKAGING INFORMATION**

Orderable Device	Status (1)	Package Type	Package Drawing	Pins	Package Qty	Eco Plan (2)	Lead finish/ Ball material (6)	MSL Peak Temp (3)	Op Temp (°C)	Device Marking (4/5)	Samples
TPS51211DSCR	ACTIVE	WSON	DSC	10	3000	RoHS & Green	NIPDAU   NIPDAUAG	Level-2-260C-1 YEAR	-40 to 85	S51211	<a href="#">Samples</a>
TPS51211DSCT	ACTIVE	WSON	DSC	10	250	RoHS & Green	NIPDAU   NIPDAUAG	Level-2-260C-1 YEAR	-40 to 85	S51211	<a href="#">Samples</a>

(1) The marketing status values are defined as follows:

**ACTIVE:** Product device recommended for new designs.

**LIFEBUY:** TI has announced that the device will be discontinued, and a lifetime-buy period is in effect.

**NRND:** Not recommended for new designs. Device is in production to support existing customers, but TI does not recommend using this part in a new design.

**PREVIEW:** Device has been announced but is not in production. Samples may or may not be available.

**OBSELETE:** TI has discontinued the production of the device.

(2) **RoHS:** TI defines "RoHS" to mean semiconductor products that are compliant with the current EU RoHS requirements for all 10 RoHS substances, including the requirement that RoHS substance do not exceed 0.1% by weight in homogeneous materials. Where designed to be soldered at high temperatures, "RoHS" products are suitable for use in specified lead-free processes. TI may reference these types of products as "Pb-Free".

**RoHS Exempt:** TI defines "RoHS Exempt" to mean products that contain lead but are compliant with EU RoHS pursuant to a specific EU RoHS exemption.

**Green:** TI defines "Green" to mean the content of Chlorine (Cl) and Bromine (Br) based flame retardants meet JS709B low halogen requirements of <=1000ppm threshold. Antimony trioxide based flame retardants must also meet the <=1000ppm threshold requirement.

(3) MSL, Peak Temp. - The Moisture Sensitivity Level rating according to the JEDEC industry standard classifications, and peak solder temperature.

(4) There may be additional marking, which relates to the logo, the lot trace code information, or the environmental category on the device.

(5) Multiple Device Markings will be inside parentheses. Only one Device Marking contained in parentheses and separated by a "~" will appear on a device. If a line is indented then it is a continuation of the previous line and the two combined represent the entire Device Marking for that device.

(6) Lead finish/Ball material - Orderable Devices may have multiple material finish options. Finish options are separated by a vertical ruled line. Lead finish/Ball material values may wrap to two lines if the finish value exceeds the maximum column width.

**Important Information and Disclaimer:**The information provided on this page represents TI's knowledge and belief as of the date that it is provided. TI bases its knowledge and belief on information provided by third parties, and makes no representation or warranty as to the accuracy of such information. Efforts are underway to better integrate information from third parties. TI has taken and continues to take reasonable steps to provide representative and accurate information but may not have conducted destructive testing or chemical analysis on incoming materials and chemicals. TI and TI suppliers consider certain information to be proprietary, and thus CAS numbers and other limited information may not be available for release.

In no event shall TI's liability arising out of such information exceed the total purchase price of the TI part(s) at issue in this document sold by TI to Customer on an annual basis.



**TAPE AND REEL INFORMATION**

**QUADRANT ASSIGNMENTS FOR PIN 1 ORIENTATION IN TAPE**

\*All dimensions are nominal

Device	Package Type	Package Drawing	Pins	SPQ	Reel Diameter (mm)	Reel Width W1 (mm)	A0 (mm)	B0 (mm)	K0 (mm)	P1 (mm)	W (mm)	Pin1 Quadrant
TPS51211DSCR	WSO	DSC	10	3000	330.0	12.4	3.3	3.3	1.1	8.0	12.0	Q2
TPS51211DSCR	WSO	DSC	10	3000	330.0	12.4	3.3	3.3	1.1	8.0	12.0	Q2
TPS51211DSCT	WSO	DSC	10	250	180.0	12.4	3.3	3.3	1.1	8.0	12.0	Q2
TPS51211DSCT	WSO	DSC	10	250	180.0	12.5	3.3	3.3	1.1	8.0	12.0	Q2



**TAPE AND REEL BOX DIMENSIONS**

\*All dimensions are nominal

Device	Package Type	Package Drawing	Pins	SPQ	Length (mm)	Width (mm)	Height (mm)
TPS51211DSCR	WSON	DSC	10	3000	346.0	346.0	33.0
TPS51211DSCR	WSON	DSC	10	3000	338.0	355.0	50.0
TPS51211DSCT	WSON	DSC	10	250	210.0	185.0	35.0
TPS51211DSCT	WSON	DSC	10	250	205.0	200.0	33.0

## GENERIC PACKAGE VIEW

DSC 10

WSON - 0.8 mm max height

PLASTIC SMALL OUTLINE - NO LEAD

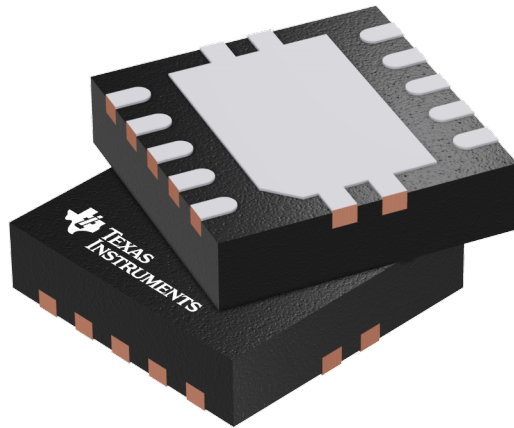

Images above are just a representation of the package family, actual package may vary.  
Refer to the product data sheet for package details.

4207383/F

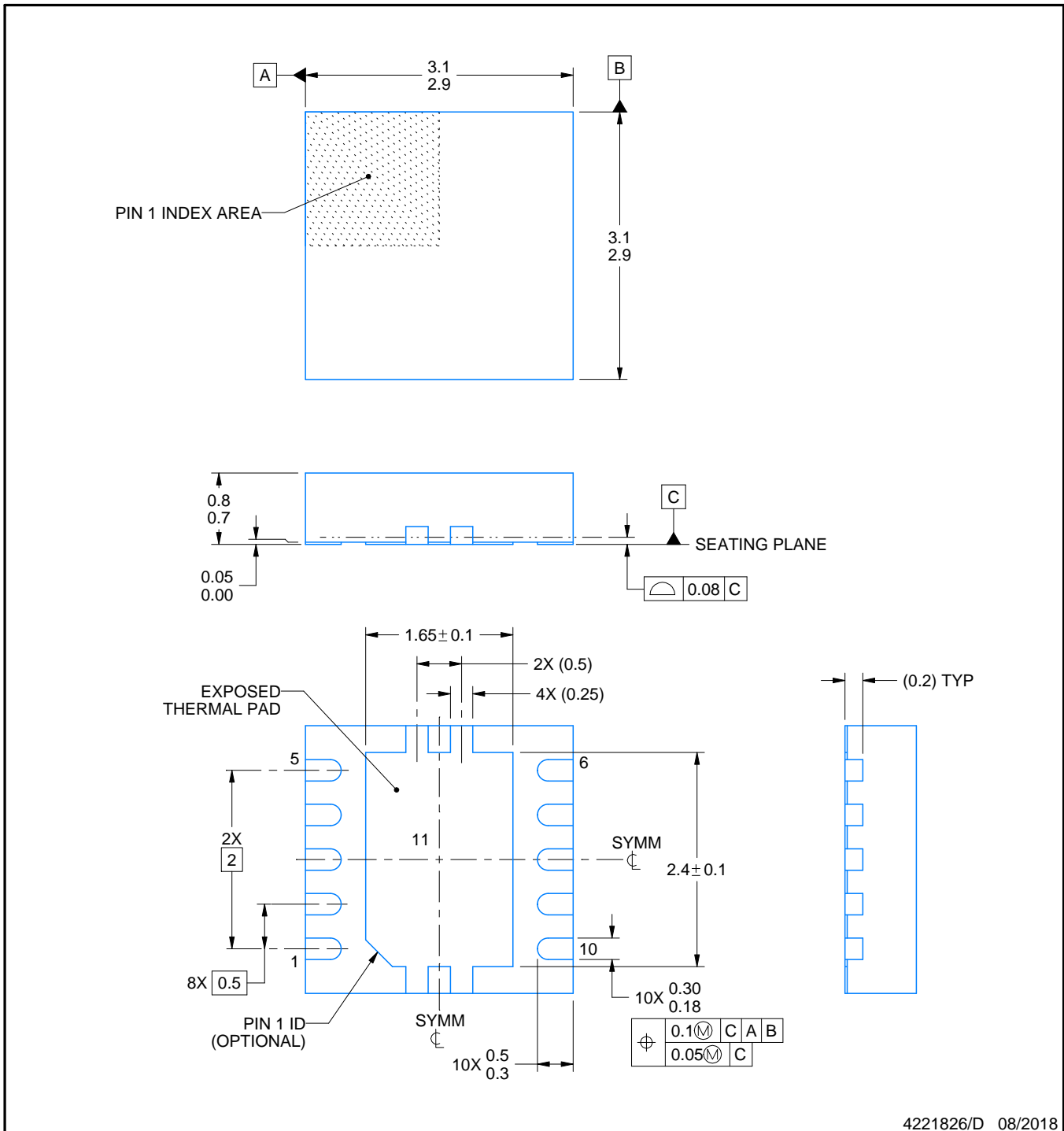
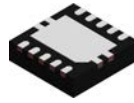

4221826/D 08/2018

NOTES:

1. All linear dimensions are in millimeters. Any dimensions in parenthesis are for reference only. Dimensioning and tolerancing per ASME Y14.5M.
2. This drawing is subject to change without notice.
3. The package thermal pad must be soldered to the printed circuit board for optimal thermal and mechanical performance.



# EXAMPLE STENCIL DESIGN

DSC0010J

WSON - 0.8 mm max height

PLASTIC SMALL OUTLINE - NO LEAD



SOLDER PASTE EXAMPLE  
BASED ON 0.125 mm THICK STENCIL

EXPOSED PAD 11:  
80% PRINTED SOLDER COVERAGE BY AREA  
SCALE:25X

4221826/D 08/2018

NOTES: (continued)

6. Laser cutting apertures with trapezoidal walls and rounded corners may offer better paste release. IPC-7525 may have alternate design recommendations.

## IMPORTANT NOTICE AND DISCLAIMER

TI PROVIDES TECHNICAL AND RELIABILITY DATA (INCLUDING DATA SHEETS), DESIGN RESOURCES (INCLUDING REFERENCE DESIGNS), APPLICATION OR OTHER DESIGN ADVICE, WEB TOOLS, SAFETY INFORMATION, AND OTHER RESOURCES "AS IS" AND WITH ALL FAULTS, AND DISCLAIMS ALL WARRANTIES, EXPRESS AND IMPLIED, INCLUDING WITHOUT LIMITATION ANY IMPLIED WARRANTIES OF MERCHANTABILITY, FITNESS FOR A PARTICULAR PURPOSE OR NON-INFRINGEMENT OF THIRD PARTY INTELLECTUAL PROPERTY RIGHTS.

These resources are intended for skilled developers designing with TI products. You are solely responsible for (1) selecting the appropriate TI products for your application, (2) designing, validating and testing your application, and (3) ensuring your application meets applicable standards, and any other safety, security, regulatory or other requirements.

These resources are subject to change without notice. TI grants you permission to use these resources only for development of an application that uses the TI products described in the resource. Other reproduction and display of these resources is prohibited. No license is granted to any other TI intellectual property right or to any third party intellectual property right. TI disclaims responsibility for, and you will fully indemnify TI and its representatives against, any claims, damages, costs, losses, and liabilities arising out of your use of these resources.

TI's products are provided subject to [TI's Terms of Sale](#) or other applicable terms available either on [ti.com](https://www.ti.com) or provided in conjunction with such TI products. TI's provision of these resources does not expand or otherwise alter TI's applicable warranties or warranty disclaimers for TI products.

TI objects to and rejects any additional or different terms you may have proposed.

Mailing Address: Texas Instruments, Post Office Box 655303, Dallas, Texas 75265  
Copyright © 2023, Texas Instruments Incorporated