

TS5A3359 1- Ω SP3T Bidirectional Analog Switch

5-V/3.3-V Single-Channel 3:1 Multiplexer and Demultiplexer

1 Features

- Isolation in power-down mode, $V_{CC} = 0$
- Specified break-before-make switching
- Low ON-state resistance (1 Ω)
- Control inputs are 5.5 V tolerant
- Low charge injection (5 pC $V_{CC} = 1.8$ V)
- Excellent ON-state resistance matching
- Low total harmonic distortion (THD)
- 1.65 V to 5.5 V single-supply operation
- Latch-up performance exceeds 100 mA per JESD 78, Class II
- ESD performance tested per JESD 22
 - 2000-V human-body model (A114-B, Class II)
 - 1000-V charged-device model (C101)

2 Applications

- Cell phones
- PDAs
- Portable instrumentation
- Audio and video signal routing
- Low-voltage data acquisition systems
- Communication circuits
- Modems
- Hard drives
- Computer peripherals
- Wireless terminals and peripherals

3 Description

The TS5A3359 device is a bidirectional, single channel, single-pole triple-throw (SP3T) analog switch that is designed to operate from 1.65 V to 5.5 V. This device provides a signal switching solution while maintaining excellent signal integrity, which makes the TS5A3359 suitable for a wide range of applications in various markets including personal electronics, test and measurement equipment, and portable instrumentation. The device maintains the signal integrity by its low ON-state resistance, excellent ON-state resistance matching, and total harmonic distortion (THD) performance. To prevent signal distortion during the transferring of a signal from one channel to another, the TS5A3359 device also has a specified break-before-make feature. The device consumes very low power and provides isolation when $V_{CC} = 0$.

Device Information⁽¹⁾

PART NUMBER	PACKAGE	BODY SIZE (NOM)
TS5A3359	US8 (8)	2.30 mm × 2.00 mm
	DSBGA (8)	1.25 mm × 2.25 mm

(1) For all available packages, see the orderable addendum at the end of the data sheet.

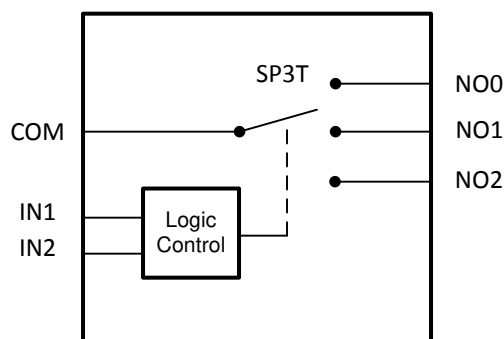

Simplified Schematic



Table of Contents

1 Features	1	8.2 Functional Block Diagram.....	22
2 Applications	1	8.3 Feature Description.....	22
3 Description	1	8.4 Device Functional Modes.....	22
4 Revision History	2	9 Application and Implementation	23
5 Pin Configuration and Functions	3	9.1 Application Information.....	23
6 Specifications	4	9.2 Typical Application.....	23
6.1 Absolute Maximum Ratings.....	4	10 Power Supply Recommendations	24
6.2 ESD Ratings.....	4	11 Layout	25
6.3 Recommended Operating Conditions.....	4	11.1 Layout Guidelines.....	25
6.4 Thermal Information.....	5	11.2 Layout Example.....	25
6.5 Electrical Characteristics for 5-V Supply.....	5	12 Device and Documentation Support	26
6.6 Electrical Characteristics for 3.3-V Supply.....	7	12.1 Receiving Notification of Documentation Updates.....	26
6.7 Electrical Characteristics for 2.5-V Supply.....	9	12.2 Support Resources.....	26
6.8 Electrical Characteristics for 1.8-V Supply.....	11	12.3 Trademarks.....	26
6.9 Typical Characteristics.....	13	12.4 Electrostatic Discharge Caution.....	26
7 Parameter Measurement Information	16	12.5 Glossary.....	26
8 Detailed Description	22	13 Mechanical, Packaging, and Orderable Information	26
8.1 Overview.....	22		

4 Revision History

NOTE: Page numbers for previous revisions may differ from page numbers in the current version.

Changes from Revision E (January 2016) to Revision F (December 2021)	Page
• Updated the numbering format for tables, figures, and cross-references throughout the document.....	1
• Updated the body size for the DSBGA (8) package in the <i>Device Information</i> table.....	1
Changes from Revision D (May 2015) to Revision E (January 2016)	Page
• Added T _J Junction Temperature to the <i>Absolute Maximum Ratings</i>	4
• Changed Input leakage current UNIT value From: μ A To: nA in <i>Electrical Characteristics for 5-V Supply</i>	5
Changes from Revision C (June 2008) to Revision D (May 2015)	Page
• Added <i>ESD Ratings</i> table, <i>Feature Description</i> section, <i>Device Functional Modes</i> , <i>Application and Implementation</i> section, <i>Power Supply Recommendations</i> section, <i>Layout</i> section, <i>Device and Documentation Support</i> section, and <i>Mechanical, Packaging, and Orderable Information</i> section	1
• Changed YZP pinout numbering.....	3

5 Pin Configuration and Functions

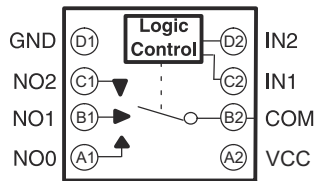

Figure 5-1. YZP Package 8-Pin DSBGA Bottom View

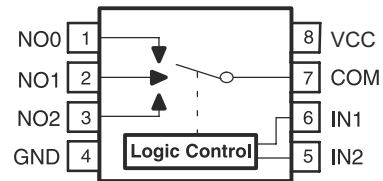

Figure 5-2. DCU Package 8-Pin US8 Top View

Table 5-1. Pin Functions

NAME	PIN		TYPE ⁽¹⁾	DESCRIPTION
	DCU	YZP		
NO0	1	A1	I/O	Normally open
NO1	2	B1	I/O	Normally open
NO2	3	C1	I/O	Normally open
GND	4	D1	—	Ground
IN2	5	D2	I	Digital control to connect COM to NO
IN1	6	C2	I	Digital control to connect COM to NO
COM	7	B2	I/O	Common
VCC	8	A2	—	Power supply

(1) I = input, O = output.

6 Specifications

6.1 Absolute Maximum Ratings

over operating free-air temperature range (unless otherwise noted)^{(1) (2)}

			MIN	MAX	UNIT
V _{CC}	Supply voltage ⁽³⁾		-0.5	6.5	V
V _{NO} V _{COM}	Analog voltage ^{(3) (4) (5)}		-0.5	V _{CC} + 0.5	V
I _K	Analog port diode current	V _{NO} , V _{COM} < 0	-50		mA
I _{NO} I _{COM}	On-state switch current	V _{NO} , V _{COM} = 0 to V _{CC}	-200 -400	200 400	mA
V _I	Digital input voltage ^{(3) (4)}		-0.5	6.5	V
I _{IK}	Digital input clamp current	V _I < 0	-50		mA
I _{CC}	Continuous current through V _{CC}			100	mA
I _{GND}	Continuous current through GND		-100	100	mA
T _{stg}	Storage temperature		-65	150	°C
T _J	Junction temperature			150	°C

- (1) Stresses beyond those listed under *Absolute Maximum Ratings* may cause permanent damage to the device. These are stress ratings only, which do not imply functional operation of the device at these or any other conditions beyond those indicated under *Recommended Operating Conditions*. Exposure to absolute-maximum-rated conditions for extended periods may affect device reliability.
- (2) The algebraic convention, whereby the most negative value is a minimum and the most positive value is a maximum
- (3) All voltages are with respect to ground, unless otherwise specified.
- (4) The input and output voltage ratings may be exceeded if the input and output clamp-current ratings are observed.
- (5) This value is limited to 5.5-V maximum.

6.2 ESD Ratings

		VALUE	UNIT
V _(ESD)	Electrostatic discharge		
	Human body model (HBM), per ANSI/ESDA/JEDEC JS-001, all pins ⁽¹⁾	±2000	V
Charged device model (CDM), per JEDEC specification JESD22-C101, all pins ⁽²⁾	±1000		

- (1) JEDEC document JEP155 states that 500-V HBM allows safe manufacturing with a standard ESD control process.
- (2) JEDEC document JEP157 states that 250-V CDM allows safe manufacturing with a standard ESD control process.

6.3 Recommended Operating Conditions

over operating free-air temperature range (unless otherwise noted)

		MIN	MAX	UNIT
V _{CC}	Analog voltage	1.65	5.5	V
V _{NO} V _{COM}		0	V _{CC}	V
V _I	Digital input voltage	0	V _{CC}	V

6.4 Thermal Information

THERMAL METRIC ⁽¹⁾		TS5A3359		UNIT
		DCU (US8)	YZP (DSBGA)	
		8 PINS	8 PINS	
R _{θJA}	Junction-to-ambient thermal resistance	204.2	105.8	°C/W
R _{θJC(top)}	Junction-to-case (top) thermal resistance	76.2	1.6	°C/W
R _{θJB}	Junction-to-board thermal resistance	82.9	10.8	°C/W
ψ _{JT}	Junction-to-top characterization parameter	7.6	3.1	°C/W
ψ _{JB}	Junction-to-board characterization parameter	82.5	10.8	°C/W

(1) For more information about traditional and new thermal metrics, see the *Semiconductor and IC Package Thermal Metrics* application report, [SPRA953](#).

6.5 Electrical Characteristics for 5-V Supply

V_{CC} = 4.5 V to 5.5 V, T_A = –40°C to 85°C (unless otherwise noted)⁽¹⁾

PARAMETER		TEST CONDITIONS		T _A	V _{CC}	MIN	TYP	MAX	UNIT	
ANALOG SWITCH										
Analog signal range	V _{COM} , V _{NO}					0		V _{CC}	V	
Peak ON resistance	r _{peak}	0 ≤ (V _{NO}) ≤ V _{CC} , I _{COM} = –100 mA,	Switch ON, See Figure 7-1	25°C	4.5 V		0.8	1.1	Ω	
				Full				1.5		
ON-state resistance	r _{on}	V _{NO} = 2.5 V, I _{COM} = –100 mA,	Switch ON, See Figure 7-1	25°C	4.5 V		0.7	0.9	Ω	
				Full				1.1		
ON-state resistance match between channels	Δr _{on}	V _{NO} = 2.5 V, I _{COM} = –100 mA,	Switch ON, See Figure 7-1	25°C	4.5 V		0.1	0.1	Ω	
				Full				0.1		
ON-state resistance flatness	r _{on(flat)}	0 ≤ (V _{NO}) ≤ V _{CC} , I _{COM} = –100 mA,	Switch ON, See Figure 7-1	25°C	4.5 V		0.15		Ω	
		V _{NO} = 1 V, 1.5 V, 2.5 V, I _{COM} = –100 mA,	Switch ON, See Figure 7-1	25°C				0.1		0.25
				Full						0.25
NO OFF leakage current	I _{NO(OFF)}	V _{NO} = 1 V or 4.5 V, V _{COM} = 1 V to 4.5 V,	Switch OFF, See Figure 7-2	25°C	5.5 V	–20	5	20	nA	
				Full			–150			150
NO ON leakage current	I _{NO(PWROFF)}	V _{NO} = 0 to 5.5 V, V _{COM} = 5.5 V to 0,	Switch OFF, See Figure 7-2	25°C	0 V	–1	0.8	1	μA	
				Full			–25			25
NO ON leakage current	I _{NO(ON)}	V _{NO} = 1 V or 4.5 V, V _{COM} = Open,	Switch ON, See Figure 7-2	25°C	5.5 V	–30	5	30	nA	
				Full			–220			220
COM OFF leakage current	I _{COM(OFF)}	V _{NO} = 4.5 V or 1 V, V _{COM} = 1 V or 4.5 V,	Switch OFF, See Figure 7-2	25°C	5.5 V	–25	8	25	nA	
				Full			–250			250
COM OFF leakage current	I _{COM(PWROFF)}	V _{COM} = 0 to 5.5 V, V _{NO} = 5.5 V to 0,	Switch OFF, See Figure 7-2	25°C	0 V	–8	0.1	8	μA	
				Full			–50			50
COM ON leakage current	I _{COM(ON)}	V _{NO} = Open, V _{COM} = 1 V or 4.5 V,	Switch ON, See Figure 7-2	25°C	5.5 V	–30	5	30	nA	
				Full			–220			220
DIGITAL CONTROL INPUTS (IN1, IN2)⁽²⁾										
Input logic high	V _{IH}			Full		2.4		5.5	V	
Input logic low	V _{IL}			Full		0		0.8	V	
Input leakage current	I _{IH} , I _{IL}	V _I = 5.5 V or 0		25°C	5.5 V	–2		2	nA	
				Full			–20			20

6.5 Electrical Characteristics for 5-V Supply (continued)

 $V_{CC} = 4.5\text{ V to }5.5\text{ V}$, $T_A = -40^\circ\text{C to }85^\circ\text{C}$ (unless otherwise noted)⁽¹⁾

PARAMETER	TEST CONDITIONS	T_A	V_{CC}	MIN	TYP	MAX	UNIT	
DYNAMIC								
Turnon time t_{ON}	$V_{COM} = V_{CC}$, $R_L = 50\ \Omega$,	$C_L = 35\text{ pF}$, See Figure 7-5	25°C	5 V	1	2.5	21	ns
			Full	4.5 V to 5.5 V	1		23.5	
Turnoff time t_{OFF}	$V_{COM} = V_{CC}$, $R_L = 50\ \Omega$,	$C_L = 35\text{ pF}$, See Figure 7-5	25°C	5 V	1	6	10.5	ns
			Full	4.5 V to 5.5 V	1		12	
Break-before-make time t_{BBM}	$V_{NO} = V_{CC}$, $R_L = 50\ \Omega$,	$C_L = 35\text{ pF}$, See Figure 7-6	25°C	5 V	0.5	8.5	18	ns
			Full	4.5 V to 5.5 V	0.5		23	
Charge injection Q_C	$V_{GEN} = 0$, $R_{GEN} = 0$,	$C_L = 1\text{ nF}$, See Figure 7-10	25°C	5 V		20	pC	
NO OFF capacitance $C_{NO(OFF)}$	$V_{NO} = V_{CC}$ or GND, Switch OFF,	See Figure 7-4	25°C	5 V		18	pF	
COM OFF capacitance $C_{COM(OFF)}$	$V_{COM} = V_{CC}$ or GND, Switch OFF,	See Figure 7-4	25°C	2.5 V		54	pF	
NO ON capacitance $C_{NO(ON)}$	$V_{NO} = V_{CC}$ or GND, Switch ON,	See Figure 7-4	25°C	5 V		78	pF	
COM ON capacitance $C_{COM(ON)}$	$V_{COM} = V_{CC}$ or GND, Switch ON,	See Figure 7-4	25°C	5 V		78	pF	
Digital input capacitance C_I	$V_I = V_{CC}$ or GND,	See Figure 7-4	25°C	5 V		2.5	pF	
Bandwidth BW	$R_L = 50\ \Omega$, Switch ON,	See Figure 7-7	25°C	5 V		75	MHz	
OFF isolation O_{ISO}	$R_L = 50\ \Omega$, $f = 1\text{ MHz}$,	Switch OFF, See Figure 7-8	25°C	5 V		-64	dB	
Crosstalk X_{TALK}	$R_L = 50\ \Omega$, $f = 1\text{ MHz}$,	Switch ON, See Figure 7-9	25°C	5 V		-64	dB	
Total harmonic distortion THD	$R_L = 600\ \Omega$, $C_L = 50\text{ pF}$,	$f = 20\text{ Hz to }20\text{ kHz}$, See Figure 7-11	25°C	5 V		0.005%		
SUPPLY								
Positive supply current I_{CC}	$V_I = V_{CC}$ or GND,	Switch ON or OFF	25°C	5.5 V		16	50	nA
			Full				1200	

- (1) The algebraic convention, whereby the most negative value is a minimum and the most positive value is a maximum
 (2) All unused digital inputs of the device must be held at V_{CC} or GND to ensure proper device operation. Refer to the TI application report, *Implications of Slow or Floating CMOS Inputs (SCBA004)*.

6.6 Electrical Characteristics for 3.3-V Supply

 $V_{CC} = 3\text{ V to }3.6\text{ V}$, $T_A = -40^\circ\text{C to }85^\circ\text{C}$ (unless otherwise noted)⁽¹⁾

PARAMETER		TEST CONDITIONS		T_A	V_{CC}	MIN	TYP	MAX	UNIT
ANALOG SWITCH									
Analogue signal range	V_{COM}, V_{NO}					0		V_{CC}	V
Peak ON resistance	r_{peak}	$0 \leq (V_{NO}) \leq V_{CC}$, $I_{COM} = -100\text{ mA}$,	Switch ON, See Figure 7-1	25°C	3 V		1.3	1.6	Ω
				Full			2		
ON-state resistance	r_{on}	$V_{NO} = 2\text{ V}$, $I_{COM} = -100\text{ mA}$,	Switch ON, See Figure 7-1	25°C	3 V		1.2	1.6	Ω
				Full			1.8		
ON-state resistance match between channels	Δr_{on}	$V_{NO} = 2\text{ V}, 0.8\text{ V}$, $I_{COM} = -100\text{ mA}$,	Switch ON, See Figure 7-1	25°C	3 V		0.1	0.15	Ω
				Full			0.15		
ON-state resistance flatness	$r_{on(Flat)}$	$0 \leq (V_{NO}) \leq V_{CC}$, $I_{COM} = -100\text{ mA}$,	Switch ON, See Figure 7-1	25°C	3 V		0.2		Ω
				25°C			0.2	0.35	
				Full			0.35		
NO OFF leakage current	$I_{NO(OFF)}$	$V_{NO} = 1\text{ V or }3\text{ V}$, $V_{COM} = 1\text{ V to }3\text{ V}$,	Switch OFF, See Figure 7-2	25°C	3.6 V	-15	3	15	nA
				Full			-30	30	
NO OFF leakage current	$I_{NO(PWROFF)}$	$V_{NO} = 0\text{ to }3.6\text{ V}$, $V_{COM} = 3.6\text{ V to }0$,	Switch OFF, See Figure 7-2	25°C	0 V	-1	0.2	1	μA
				Full			-10	10	
NO ON leakage current	$I_{NO(ON)}$	$V_{NO} = 1\text{ V or }3\text{ V}$, $V_{COM} = \text{Open}$,	Switch ON, See Figure 7-2	25°C	3.6 V	-15	3	15	nA
				Full			-40	40	
COM OFF leakage current	$I_{COM(OFF)}$	$V_{NO} = 0\text{ V to }3.6\text{ V}$, $V_{COM} = 1\text{ V or }3.6\text{ V to }0$, $V_{COM} = 3\text{ V}$,	Switch OFF, See Figure 7-2	25°C	3.6 V	-15	3	15	nA
				Full			-75	75	
COM OFF leakage current	$I_{COM(PWROFF)}$	$V_{COM} = 0\text{ to }3.6\text{ V}$, $V_{NO} = 3.6\text{ V to }0$,	Switch OFF, See Figure 7-2	25°C	0 V	-1	0.2	1	μA
				Full			-20	20	
COM ON leakage current	$I_{COM(ON)}$	$V_{NO} = \text{Open}$, $V_{COM} = 1\text{ V or }3\text{ V}$,	Switch ON, See Figure 7-2	25°C	3.6 V	-15	4	15	nA
				Full			-40	40	
DIGITAL CONTROL INPUTS (IN1, IN2)⁽²⁾									
Input logic high	V_{IH}			Full		2		5.5	V
Input logic low	V_{IL}			Full		0		0.8	V
Input leakage current	I_{IH}, I_{IL}	$V_I = 5.5\text{ V or }0$		25°C	3.6 V	-2		2	nA
				Full			-20	20	

6.6 Electrical Characteristics for 3.3-V Supply (continued)

$V_{CC} = 3\text{ V to }3.6\text{ V}$, $T_A = -40^\circ\text{C to }85^\circ\text{C}$ (unless otherwise noted)⁽¹⁾

PARAMETER		TEST CONDITIONS		T_A	V_{CC}	MIN	TYP	MAX	UNIT
DYNAMIC									
Turnon time	t_{ON}	$V_{COM} = V_{CC}$, $R_L = 50\ \Omega$,	$C_L = 35\text{ pF}$, See Figure 7-5	25°C	3.3 V	1	16	30.5	ns
				Full	3 V to 3.6 V	1		34	
Turnoff time	t_{OFF}	$V_{COM} = V_{CC}$, $R_L = 50\ \Omega$,	$C_L = 35\text{ pF}$, See Figure 7-5	25°C	3.3 V	1	6	11.5	ns
				Full	3 V to 3.6 V	1		12.5	
Break-before-make time	t_{BBM}	$V_{NO} = V_{CC}$, $R_L = 50\ \Omega$,	$C_L = 35\text{ pF}$, See Figure 7-6	25°C	3.3 V	0.5	13	26	ns
				Full	3 V to 3.6 V	0.5		30	
Charge injection	Q_C	$V_{GEN} = 0$, $R_{GEN} = 0$,	$C_L = 1\text{ nF}$, See Figure 7-10	25°C	3.3 V		12		pC
NO OFF capacitance	$C_{NO(OFF)}$	$V_{NO} = V_{CC}$ or GND, Switch OFF,	See Figure 7-4	25°C	3.3 V		18		pF
COM OFF capacitance	$C_{COM(OFF)}$	$V_{COM} = V_{CC}$ or GND, Switch OFF,	See Figure 7-4	25°C	3.3 V		55		pF
NO ON capacitance	$C_{NO(ON)}$	$V_{NO} = V_{CC}$ or GND, Switch ON,	See Figure 7-4	25°C	3.3 V		78		pF
COM ON capacitance	$C_{COM(ON)}$	$V_{COM} = V_{CC}$ or GND, Switch ON,	See Figure 7-4	25°C	3.3 V		78		pF
Digital input capacitance	C_I	$V_I = V_{CC}$ or GND,	See Figure 7-4	25°C	3.3 V		2.5		pF
Bandwidth	BW	$R_L = 50\ \Omega$, Switch ON,	See Figure 7-7	25°C	3.3 V		73		MHz
OFF isolation	O_{ISO}	$R_L = 50\ \Omega$, $f = 1\text{ MHz}$,	Switch OFF, See Figure 7-8	25°C	3.3 V		-64		dB
Crosstalk	X_{TALK}	$R_L = 50\ \Omega$, $f = 1\text{ MHz}$,	Switch ON, See Figure 7-9	25°C	3.3 V		-64		dB
Total harmonic distortion	THD	$R_L = 600\ \Omega$, $C_L = 50\text{ pF}$,	$f = 20\text{ Hz to }20\text{ kHz}$, See Figure 7-11	25°C	3.3 V		0.01%		
SUPPLY									
Positive supply current	I_{CC}	$V_I = V_{CC}$ or GND,	Switch ON or OFF	25°C	3.6 V		2	20	nA
				Full				350	

- (1) The algebraic convention, whereby the most negative value is a minimum and the most positive value is a maximum
(2) All unused digital inputs of the device must be held at V_{CC} or GND to ensure proper device operation. Refer to the TI application report, *Implications of Slow or Floating CMOS Inputs (SCBA004)*.

6.7 Electrical Characteristics for 2.5-V Supply

 $V_{CC} = 2.3\text{ V to }2.7\text{ V}$, $T_A = -40^\circ\text{C to }85^\circ\text{C}$ (unless otherwise noted)⁽¹⁾

PARAMETER		TEST CONDITIONS		T_A	V_{CC}	MIN	TYP	MAX	UNIT	
ANALOG SWITCH										
Analogue signal range	V_{COM}, V_{NO}					0		V_{CC}	V	
Peak ON resistance	r_{peak}	$0 \leq (V_{NO}) \leq V_{CC}$, $I_{COM} = -8\text{ mA}$,	Switch ON, See Figure 7-1	25°C	2.3 V		1.8	2.5	Ω	
				Full			2.7			
ON-state resistance	r_{on}	$V_{NO} = 1.8\text{ V}$, $I_{COM} = -8\text{ mA}$,	Switch ON, See Figure 7-1	25°C	2.3 V		1.5	2	Ω	
				Full			2.4			
ON-state resistance match between channels	Δr_{on}	$V_{NO} = 1.8\text{ V}$, $I_{COM} = -8\text{ mA}$,	Switch ON, See Figure 7-1	25°C	2.3 V			0.2	Ω	
				Full			0.2			
ON-state resistance flatness	$r_{on(flat)}$	$0 \leq (V_{NO}) \leq V_{CC}$, $I_{COM} = -8\text{ mA}$,	Switch ON, See Figure 7-1	25°C	2.3 V		0.6		Ω	
				25°C			0.6			
				Full			1			
NO OFF leakage current	$I_{NO(OFF)}$	$V_{NO} = 0.5\text{ V or }2.3\text{ V}$, $V_{COM} = 0.5\text{ V to }2.3\text{ V}$,	Switch OFF, See Figure 7-2	25°C	2.7 V		-15	3	15	nA
				Full			-30	30		
NO OFF leakage current	$I_{NO(PWROFF)}$	$V_{NO} = 0\text{ to }2.7\text{ V}$, $V_{COM} = 2.7\text{ V to }0$,	Switch OFF, See Figure 7-2	25°C	0 V		-1	0.1	1	μA
				Full			-10	10		
NO ON leakage current	$I_{NO(ON)}$	$V_{NO} = 0.5\text{ V or }2.3\text{ V}$, $V_{COM} = \text{Open}$,	Switch ON, See Figure 7-2	25°C	2.7 V		-15	3	15	nA
				Full			-35	35		
COM OFF leakage current	$I_{COM(OFF)}$	$V_{NO} = 0.3\text{ V to }2.3\text{ V}$, $V_{COM} = 0.5\text{ V or }2.3\text{ V}$,	Switch OFF, See Figure 7-2	25°C	2.7 V		-15	3	15	nA
				Full			-60	60		
COM OFF leakage current	$I_{COM(PWROFF)}$	$V_{COM} = 0\text{ to }2.7\text{ V}$, $V_{NO} = 2.7\text{ V to }0$,	Switch OFF, See Figure 7-2	25°C	0 V		-1	0.1	1	μA
				Full			-10	10		
COM ON leakage current	$I_{COM(ON)}$	$V_{NO} = \text{Open}$, $V_{COM} = 0.5\text{ V or }2.2\text{ V}$,	Switch ON, See Figure 7-2	25°C	2.7 V		-15	3.5	15	nA
				Full			-40	40		
DIGITAL CONTROL INPUTS (IN1, IN2)⁽²⁾										
Input logic high	V_{IH}			Full			1.8	5.5	V	
Input logic low	V_{IL}			Full			0	0.6	V	
Input leakage current	I_{IH}, I_{IL}	$V_I = 5.5\text{ V or }0$		25°C	2.7 V		1	1	nA	
				Full			10	10		

6.7 Electrical Characteristics for 2.5-V Supply (continued)

$V_{CC} = 2.3 \text{ V to } 2.7 \text{ V}$, $T_A = -40^\circ\text{C to } 85^\circ\text{C}$ (unless otherwise noted)⁽¹⁾

PARAMETER		TEST CONDITIONS		T_A	V_{CC}	MIN	TYP	MAX	UNIT
DYNAMIC									
Turnon time	t_{ON}	$V_{COM} = V_{CC}$, $R_L = 50 \Omega$,	$C_L = 35 \text{ pF}$, See Figure 7-5	25°C	2.5 V	2	4.5	43	ns
				Full	2.3 V to 2.7 V	2		47.5	
Turnoff time	t_{OFF}	$V_{COM} = V_{CC}$, $R_L = 50 \Omega$,	$C_L = 35 \text{ pF}$, See Figure 7-5	25°C	2.5 V	2	8.5	11	ns
				Full	2.3 V to 2.7 V	2		12.5	
Break-before-make time	t_{BBM}	$V_{NO} = V_{CC}$, $R_L = 50 \Omega$,	$C_L = 35 \text{ pF}$, See Figure 7-6	25°C	2.5 V	0.5	18.5	38.5	ns
				Full	2.3 V to 2.7 V	0.5		43	
Charge injection	Q_C	$V_{GEN} = 0$, $R_{GEN} = 0$,	$C_L = 1 \text{ nF}$, See Figure 7-10	25°C	2.5 V		8		pC
NO OFF capacitance	$C_{NO(OFF)}$	$V_{NO} = V_{CC}$ or GND, Switch OFF,	See Figure 7-4	25°C	2.5 V		18.5		pF
COM OFF capacitance	$C_{COM(OFF)}$	$V_{COM} = V_{CC}$ or GND, Switch OFF,	See Figure 7-4	25°C	2.5 V		55		pF
NO ON capacitance	$C_{NO(ON)}$	$V_{NO} = V_{CC}$ or GND, Switch ON,	See Figure 7-4	25°C	2.5 V		78		pF
COM ON capacitance	$C_{COM(ON)}$	$V_{COM} = V_{CC}$ or GND, Switch ON,	See Figure 7-4	25°C	2.5 V		78		pF
Digital input capacitance	C_I	$V_I = V_{CC}$ or GND,	See Figure 7-4	25°C	2.5 V		3		pF
Bandwidth	BW	$R_L = 50 \Omega$, Switch ON,	See Figure 7-7	25°C	2.5 V		73		MHz
OFF isolation	O_{ISO}	$R_L = 50 \Omega$, $f = 1 \text{ MHz}$,	Switch OFF, See Figure 7-8	25°C	2.5 V		-64		dB
Crosstalk	X_{TALK}	$R_L = 50 \Omega$, $f = 1 \text{ MHz}$,	Switch ON, See Figure 7-9	25°C	2.5 V		-64		dB
Total harmonic distortion	THD	$R_L = 600 \Omega$, $C_L = 50 \text{ pF}$,	$f = 20 \text{ Hz to } 20 \text{ kHz}$, See Figure 7-11	25°C	2.5 V		0.03%		
SUPPLY									
Positive supply current	I_{CC}	$V_I = V_{CC}$ or GND,	Switch ON or OFF	25°C	2.7 V		1	10	nA
				Full			250		

- (1) The algebraic convention, whereby the most negative value is a minimum and the most positive value is a maximum
(2) All unused digital inputs of the device must be held at V_{CC} or GND to ensure proper device operation. Refer to the TI application report, *Implications of Slow or Floating CMOS Inputs (SCBA004)*.

6.8 Electrical Characteristics for 1.8-V Supply

 $V_{CC} = 1.65\text{ V to }1.95\text{ V}$, $T_A = -40^\circ\text{C to }85^\circ\text{C}$ (unless otherwise noted)⁽¹⁾

PARAMETER		TEST CONDITIONS		T_A	V_{CC}	MIN	TYP	MAX	UNIT
ANALOG SWITCH									
Analogue signal range	V_{COM}, V_{NO}					0		V_{CC}	V
Peak ON resistance	r_{peak}	$0 \leq (V_{NO}) \leq V_{CC}$, $I_{COM} = -2\text{ mA}$,	Switch ON, See Figure 7-1	25°C	1.65 V	5		30	Ω
				Full					
ON-state resistance	r_{on}	$V_{NO} = 1.5\text{ V}$, $I_{COM} = -2\text{ mA}$,	Switch ON, See Figure 7-1	25°C	1.65 V	2		2.5	Ω
				Full		3.5			
ON-state resistance match between channels	Δr_{on}	$V_{NO} = 1.5\text{ V}$, $I_{COM} = -2\text{ mA}$,	Switch ON, See Figure 7-1	25°C	1.65 V	0.15		0.4	Ω
				Full		0.4			
ON-state resistance flatness	$r_{on(Flat)}$	$0 \leq (V_{NO}) \leq V_{CC}$, $I_{COM} = -2\text{ mA}$,	Switch ON, See Figure 7-1	25°C	1.65 V	5		Ω	
				25°C		4.5			
				Full		5			
NO OFF leakage current	$I_{NO(OFF)}$	$V_{NO} = 0.3\text{ V or }1.65\text{ V}$, $V_{COM} = 0.3\text{ V to }1.65\text{ V}$,	Switch OFF, See Figure 7-2	25°C	1.95 V	-15	3	15	nA
				Full		-30	30		
	$I_{NO(PWROFF)}$	$V_{NO} = 0\text{ to }1.95\text{ V}$, $V_{COM} = 1.95\text{ V to }0$,	Switch OFF, See Figure 7-2	25°C	0 V	-1	0.1	1	μA
				Full		-15	15		
NO ON leakage current	$I_{NO(ON)}$	$V_{NO} = 0.3\text{ V or }1.65\text{ V}$, $V_{COM} = \text{Open}$,	Switch ON, See Figure 7-2	25°C	1.95 V	-15	3	15	nA
				Full		-30	30		
COM OFF leakage current	$I_{COM(OFF)}$	$V_{NO} = 0.3\text{ V to }1.65\text{ V}$, $V_{COM} = 0.3\text{ V or }1.65\text{ V}$,	Switch OFF, See Figure 7-2	25°C	1.95 V	-15	3	15	nA
				Full		-50	50		
				25°C		0 V	-1	0.1	
Full	-10	10							
COM ON leakage current	$I_{COM(ON)}$	$V_{NO} = \text{Open}$, $V_{COM} = 0.3\text{ V or }1.65\text{ V}$,	Switch ON, See Figure 7-2	25°C	1.95 V	-15	3	15	nA
				Full		-30	30		
DIGITAL CONTROL INPUTS (IN1, IN2)⁽²⁾									
Input logic high	V_{IH}			Full		1.5		5.5	V
Input logic low	V_{IL}			Full		0		0.6	V
Input leakage current	I_{IH}, I_{IL}	$V_I = 5.5\text{ V or }0$		25°C	1.95 V	-2		2	nA
				Full		-20	20		

6.8 Electrical Characteristics for 1.8-V Supply (continued)

 $V_{CC} = 1.65\text{ V to }1.95\text{ V}$, $T_A = -40^\circ\text{C to }85^\circ\text{C}$ (unless otherwise noted)⁽¹⁾

PARAMETER		TEST CONDITIONS		T_A	V_{CC}	MIN	TYP	MAX	UNIT
DYNAMIC									
Turnon time	t_{ON}	$V_{COM} = V_{CC}$, $R_L = 50\ \Omega$,	$C_L = 35\ \text{pF}$, See Figure 7-5	25°C	1.8 V	3	38.5	85	ns
				Full	1.65 V to 1.95 V	3		90	
Turnoff time	t_{OFF}	$V_{COM} = V_{CC}$, $R_L = 50\ \Omega$,	$C_L = 35\ \text{pF}$, See Figure 7-5	25°C	1.8 V	2	8.5	16	ns
				Full	1.65 V to 1.95 V	2		18	
Break-before-make time	t_{BBM}	$V_{NO} = V_{CC}$, $R_L = 50\ \Omega$,	$C_L = 35\ \text{pF}$, See Figure 7-6	25°C	1.8 V	1	33	75	ns
				Full	1.65 V to 1.95 V	1		80	
Charge injection	Q_C	$V_{GEN} = 0$, $R_{GEN} = 0$,	$C_L = 1\ \text{nF}$, See Figure 7-10	25°C	1.8 V		5		pC
NO OFF capacitance	$C_{NO(OFF)}$	$V_{NO} = V_{CC}$ or GND, Switch OFF,	See Figure 7-4	25°C	1.8 V		18.5		pF
COM OFF capacitance	$C_{COM(OFF)}$	$V_{COM} = V_{CC}$ or GND, Switch OFF,	See Figure 7-4	25°C	1.8 V		55		pF
NO ON capacitance	$C_{NO(ON)}$	$V_{NO} = V_{CC}$ or GND, Switch ON,	See Figure 7-4	25°C	1.8 V		78		pF
COM ON capacitance	$C_{COM(ON)}$	$V_{COM} = V_{CC}$ or GND, Switch ON,	See Figure 7-4	25°C	1.8 V		78		pF
Digital input capacitance	C_i	$V_i = V_{CC}$ or GND,	See Figure 7-4	25°C	1.8 V		3		pF
Bandwidth	BW	$R_L = 50\ \Omega$, Switch ON,	See Figure 7-7	25°C	1.8 V		73		MHz
OFF isolation	O_{ISO}	$R_L = 50\ \Omega$, $f = 1\ \text{M Hz}$,	Switch OFF, See Figure 7-8	25°C	1.8 V		-64		dB
Crosstalk	X_{TALK}	$R_L = 50\ \Omega$, $f = 1\ \text{MHz}$,	Switch ON, See Figure 7-9	25°C	1.8 V		-64		dB
Total harmonic distortion	THD	$R_L = 600\ \Omega$, $C_L = 50\ \text{pF}$,	$f = 20\ \text{Hz to }20\ \text{kHz}$, See Figure 7-11	25°C	1.8 V		0.08%		
SUPPLY									
Positive supply current	I_{CC}	$V_i = V_{CC}$ or GND,	Switch ON or OFF	25°C	1.95 V	1			nA
				Full		200			

- (1) The algebraic convention, whereby the most negative value is a minimum and the most positive value is a maximum
- (2) All unused digital inputs of the device must be held at V_{CC} or GND to ensure proper device operation. Refer to the TI application report, *Implications of Slow or Floating CMOS Inputs*, [SCBA004](#).

6.9 Typical Characteristics

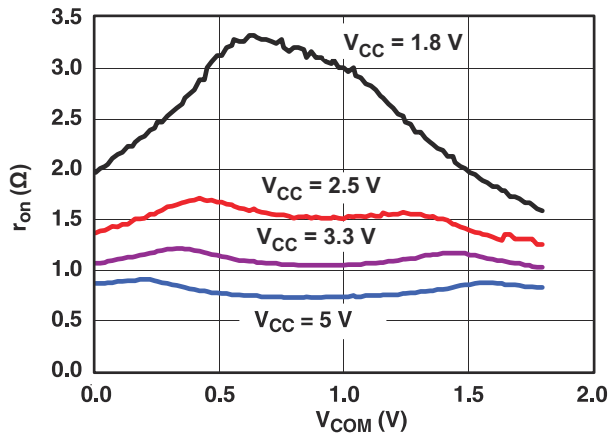

Figure 6-1. R_{on} vs V_{COM}

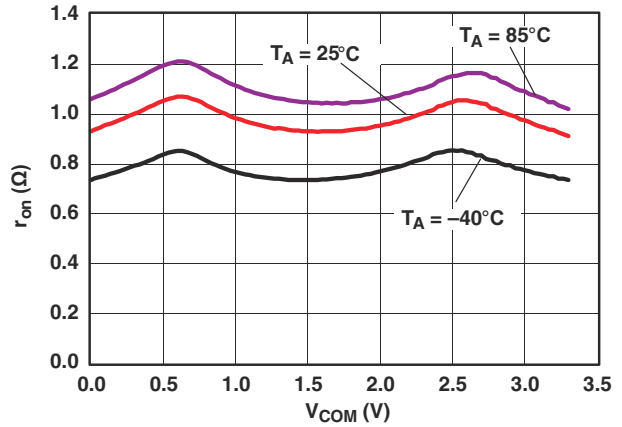

Figure 6-2. R_{on} vs V_{COM} Over Temperature ($V_{CC} = 3.3$ V)

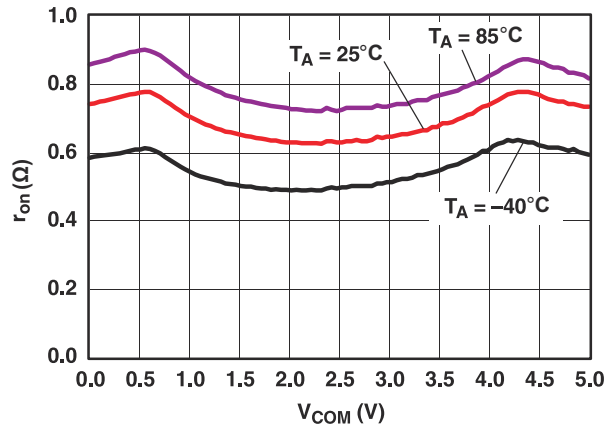

Figure 6-3. R_{on} vs V_{COM} Over Temperature ($V_{CC} = 5$ V)

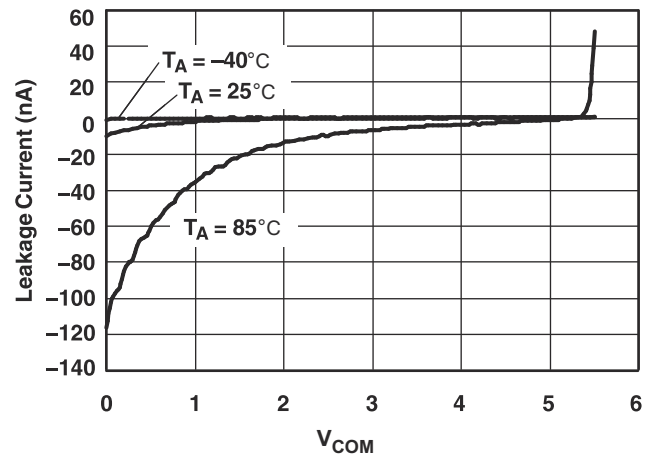

Figure 6-4. $I_{COM(OFF)}$ Leakage Current vs V_{COM} Over Temperature ($V_{CC} = 5$ V)

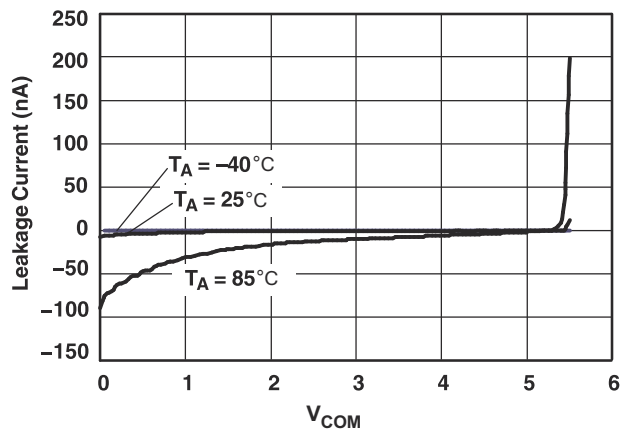

Figure 6-5. $I_{NO(OFF)}$ Leakage Current vs V_{COM} Over Temperature ($V_{CC} = 5$ V)

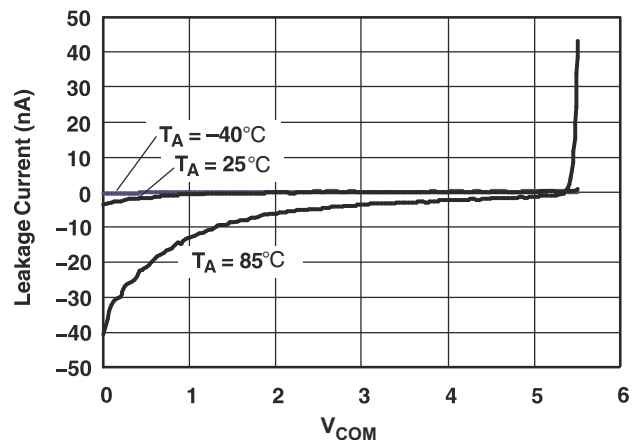

Figure 6-6. $I_{COM(ON)}$ Leakage Current vs V_{COM} Over Temperature ($V_{CC} = 5$ V)

6.9 Typical Characteristics (continued)

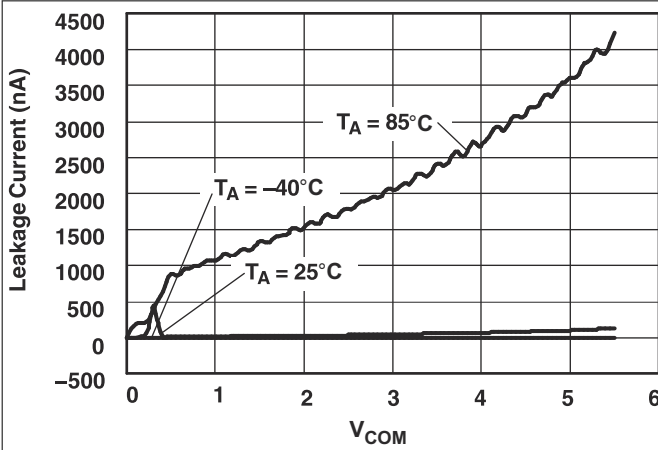

Figure 6-7. $I_{COM(PWR\ OFF)}$ Leakage Current vs V_{COM} Over Temperature ($V_{CC} = 0\ V$)

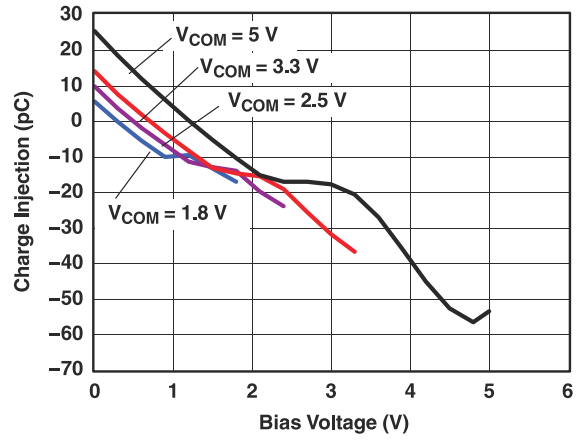

Figure 6-8. Charge Injection (Q_C) vs V_{COM}

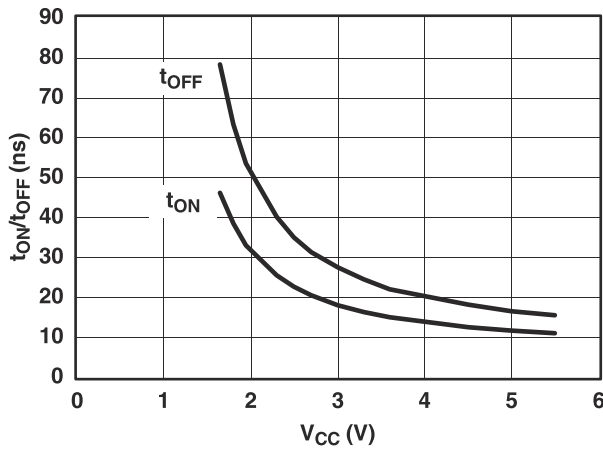

Figure 6-9. t_{ON} and t_{OFF} vs Supply Voltage

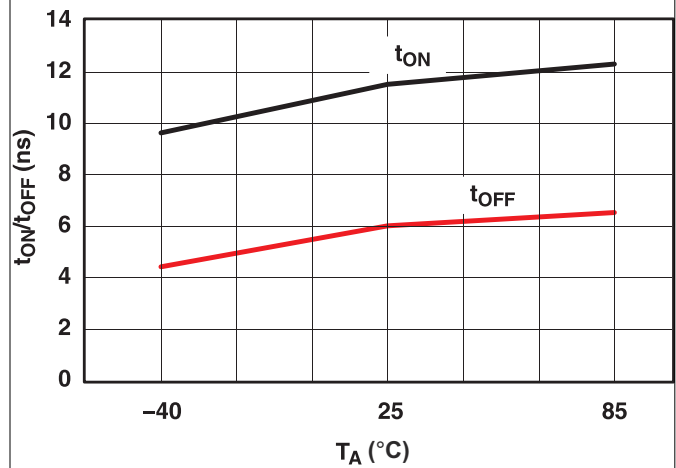

Figure 6-10. T_{ON} and T_{OFF} vs Temperature

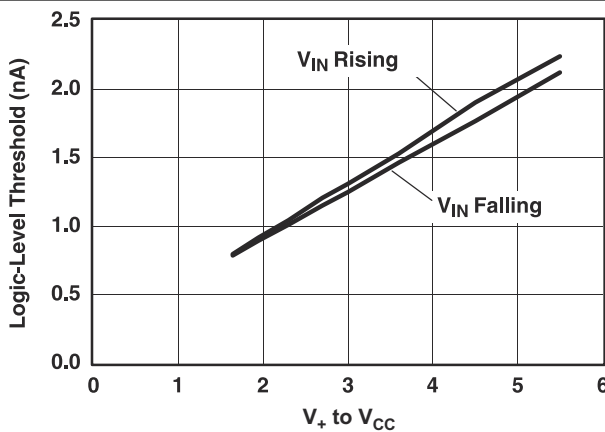

Figure 6-11. Logic-Level Threshold vs V_{CC}

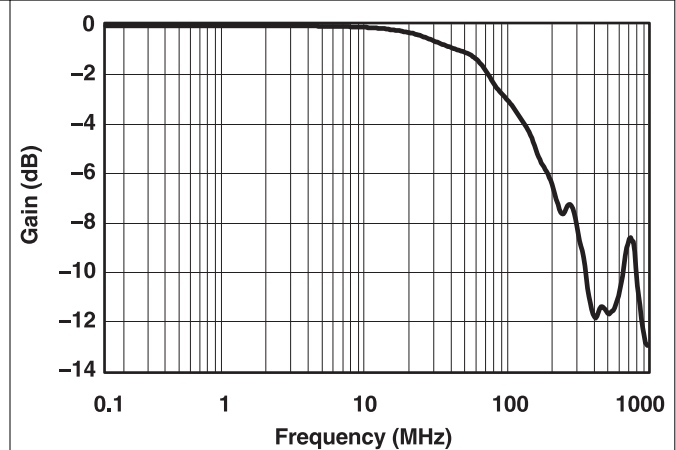

Figure 6-12. Bandwidth ($V_{CC} = 5\ V$)

6.9 Typical Characteristics (continued)

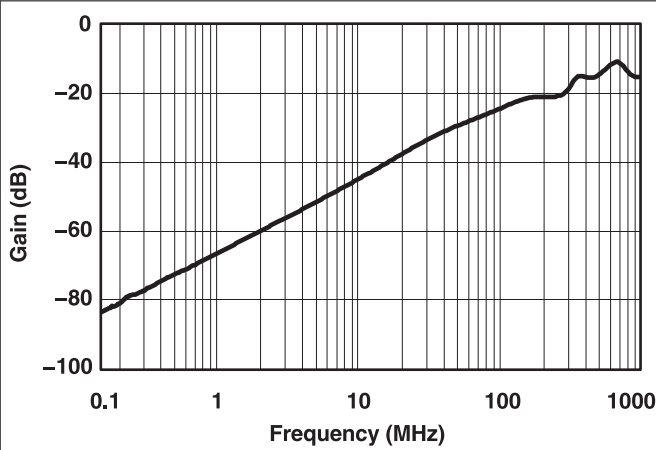

Figure 6-13. Off Isolation ($V_{CC} = 5\text{ V}$)

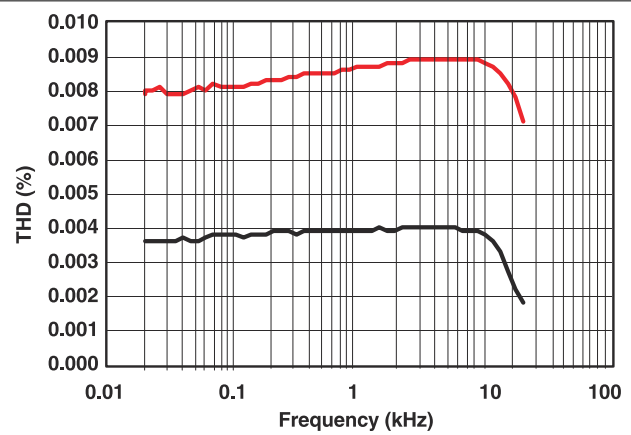

Figure 6-14. Total Harmonic Distortion vs Frequency ($V_{CC} = 5\text{ V}$)

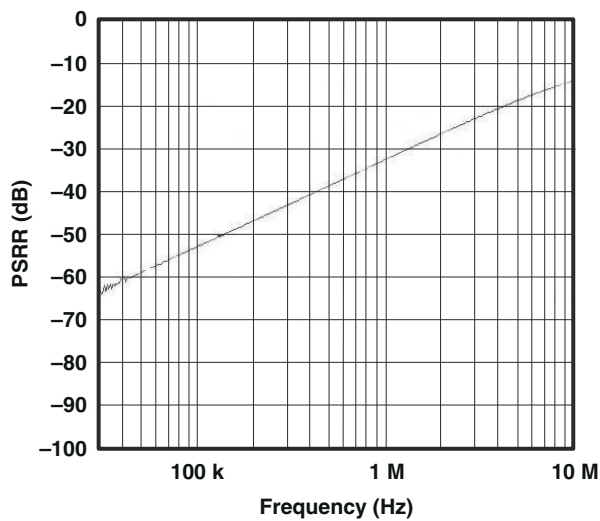

Figure 6-15. Com Port to No2 PSRR, $In1 = V_{CC}$, $In2 = V_{CC}$ ($V_{CC} = 5\text{ V}$)

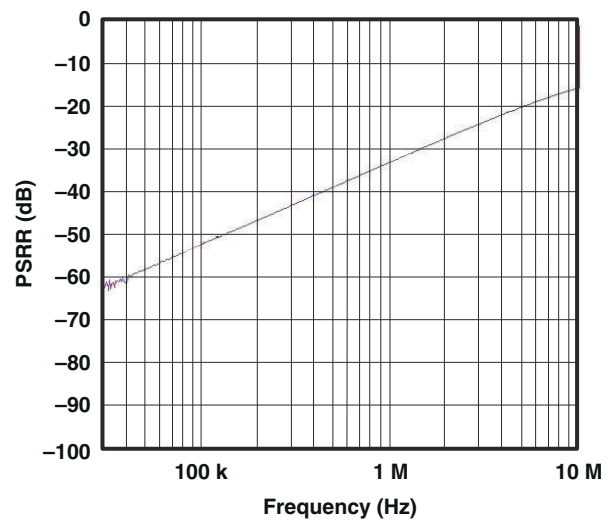

Figure 6-16. Com Port to No0 PSRR, $In1 = V_{CC}$, $In2 = V_{CC}$ ($V_{CC} = 5\text{ V}$)

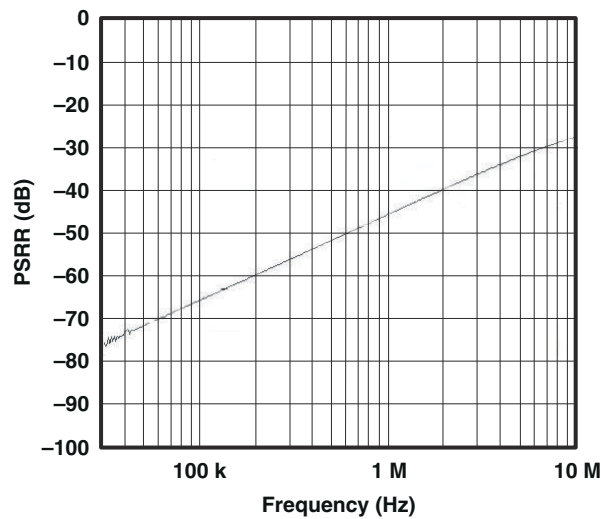

Figure 6-17. Com Port Hi-Z PSRR, $In1 = 0\text{ V}$, $In2 = 0\text{ V}$ ($V_{CC} = 5\text{ V}$)

7 Parameter Measurement Information

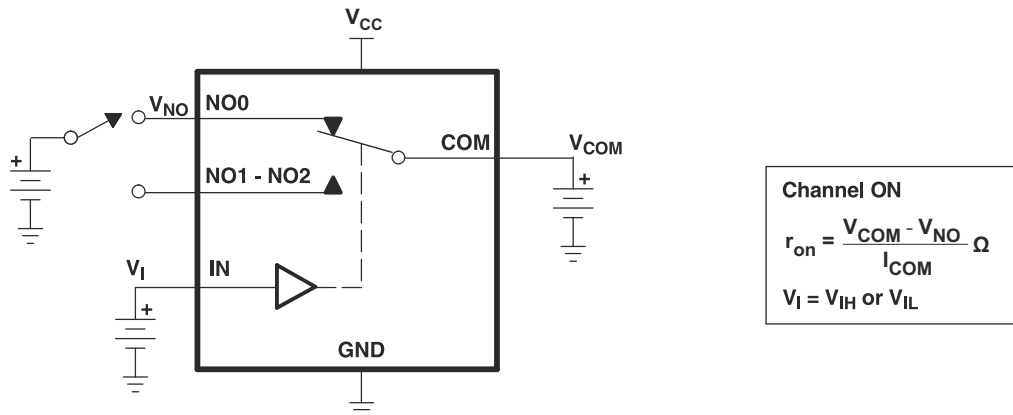

Figure 7-1. ON-State Resistance (R_{on})

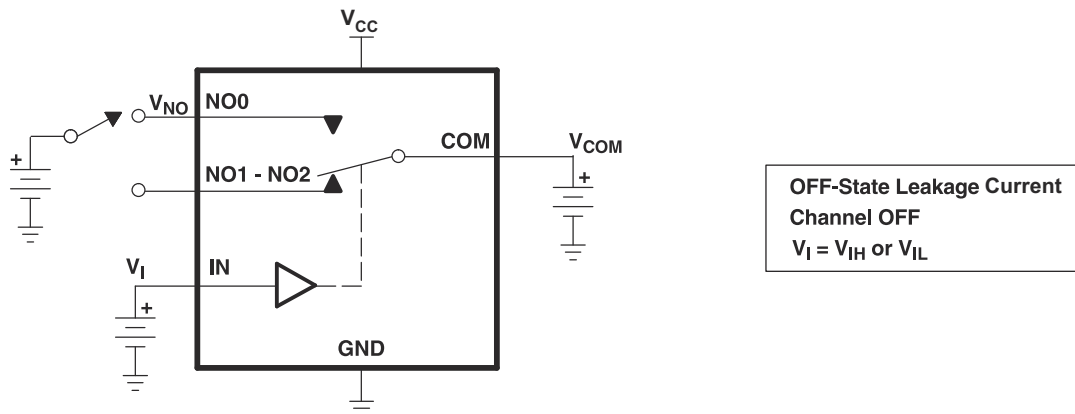

Figure 7-2. OFF-State Leakage Current ($I_{NC(OFF)}$, $I_{NO(OFF)}$, $I_{NO(PWROFF)}$, $I_{COM(OFF)}$, $I_{COM(PWROFF)}$)

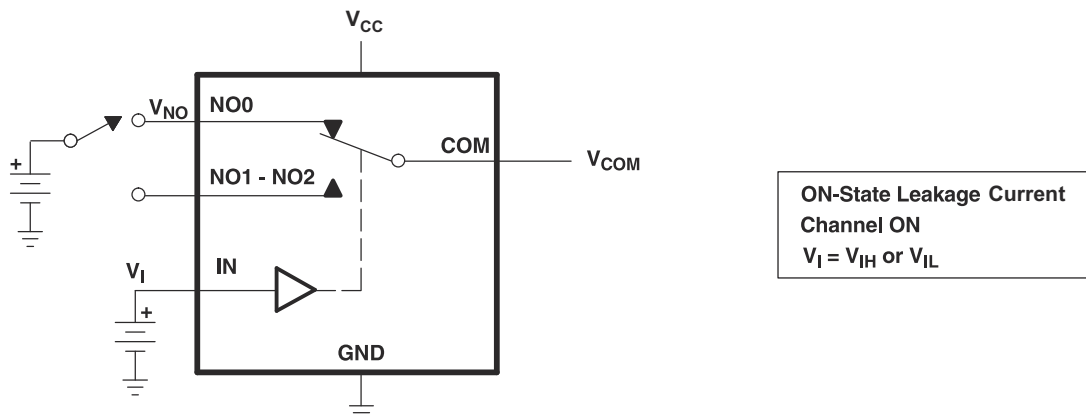

Figure 7-3. ON-State Leakage Current ($I_{COM(ON)}$, $I_{NO(ON)}$)

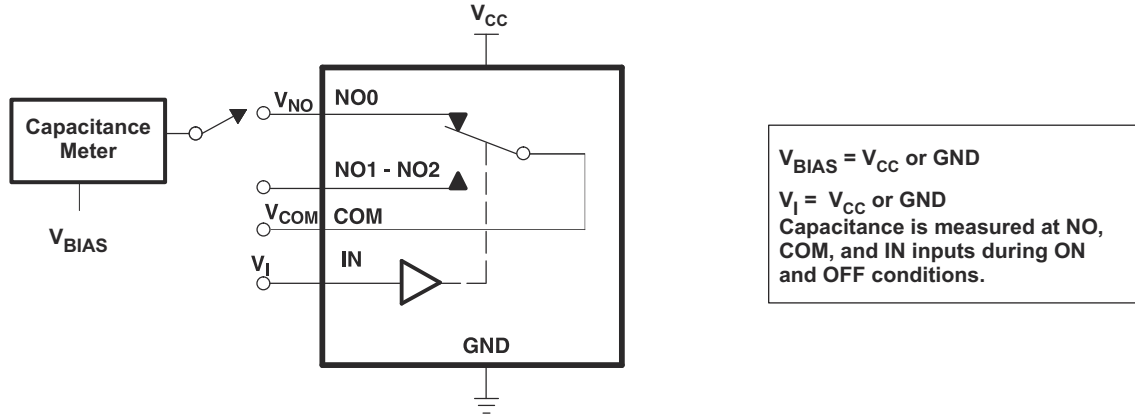
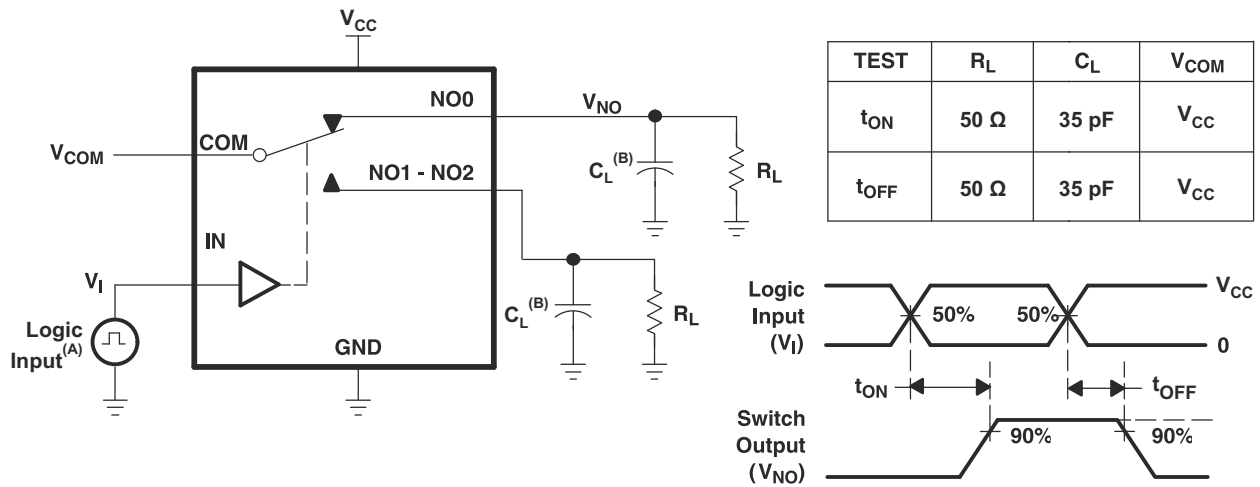
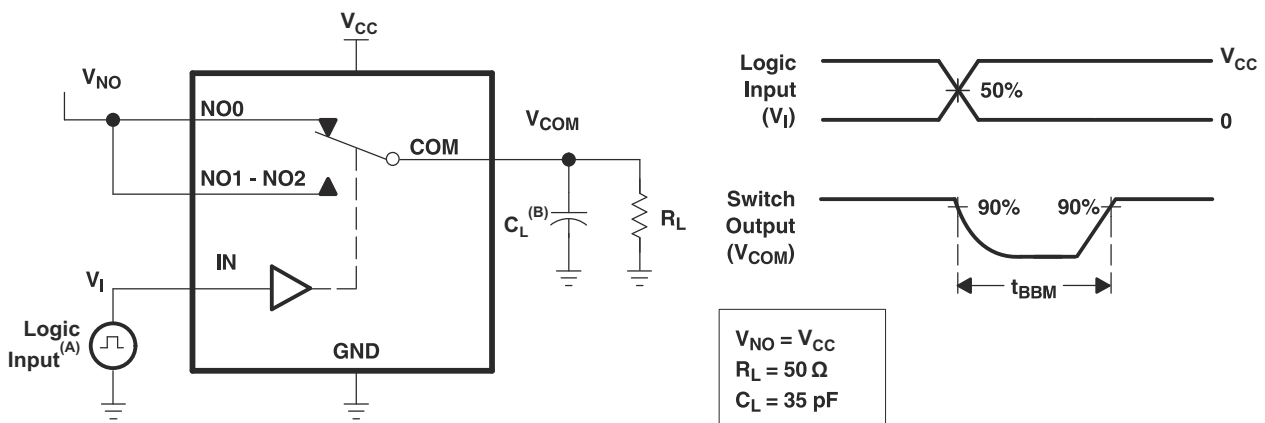

Figure 7-4. Capacitance (C_I , $C_{COM(ON)}$, $C_{NO(OFF)}$, $C_{COM(OFF)}$, $C_{NO(ON)}$)



- A. All input pulses are supplied by generators having the following characteristics: PRR \leq 10 MHz, $Z_O = 50 \Omega$, $t_r < 5$ ns, $t_f < 5$ ns.
- B. C_L includes probe and jig capacitance.

Figure 7-5. Turnon (t_{ON}) and Turnoff Time (t_{OFF})



- A. All input pulses are supplied by generators having the following characteristics: PRR \leq 10 MHz, $Z_O = 50 \Omega$, $t_r < 5$ ns, $t_f < 5$ ns.
- B. C_L includes probe and jig capacitance.

Figure 7-6. Break-Before-Make Time (t_{BBM})

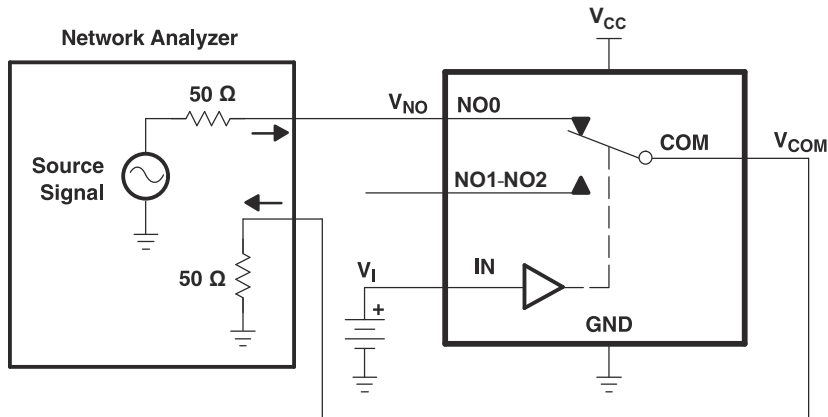

Figure 7-7. Bandwidth (BW)

Channel ON: NO0 to COM
 $V_I = V_{CC}$ or GND

Network Analyzer Setup
 Source Power = 0 dBm
 (632-mV P-P at 50-Ω load)
 DC Bias = 350 mV

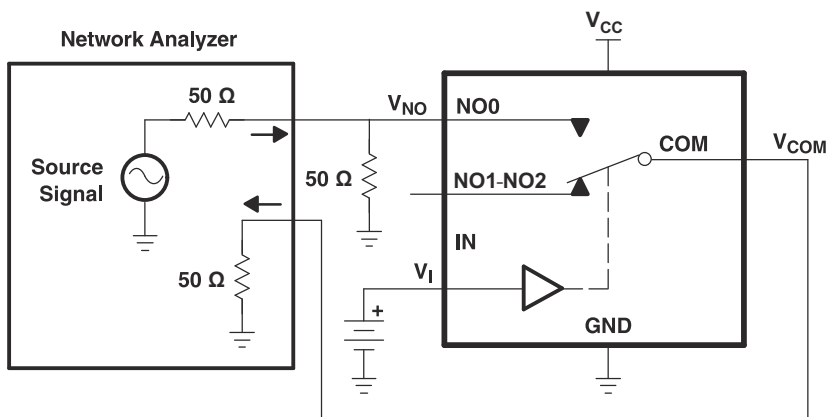

Figure 7-8. Off Isolation (O_{ISO})

Channel OFF: NO0 to COM
 $V_I = V_{CC}$ or GND

Network Analyzer Setup
 Source Power = 0 dBm
 (632-mV P-P at 50-Ω load)
 DC Bias = 350 mV

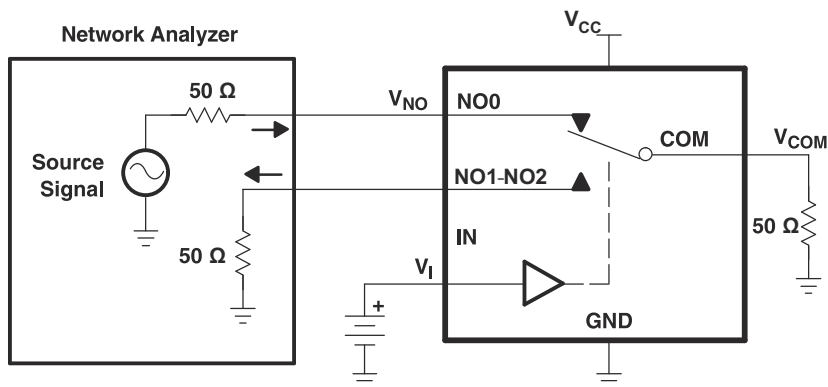
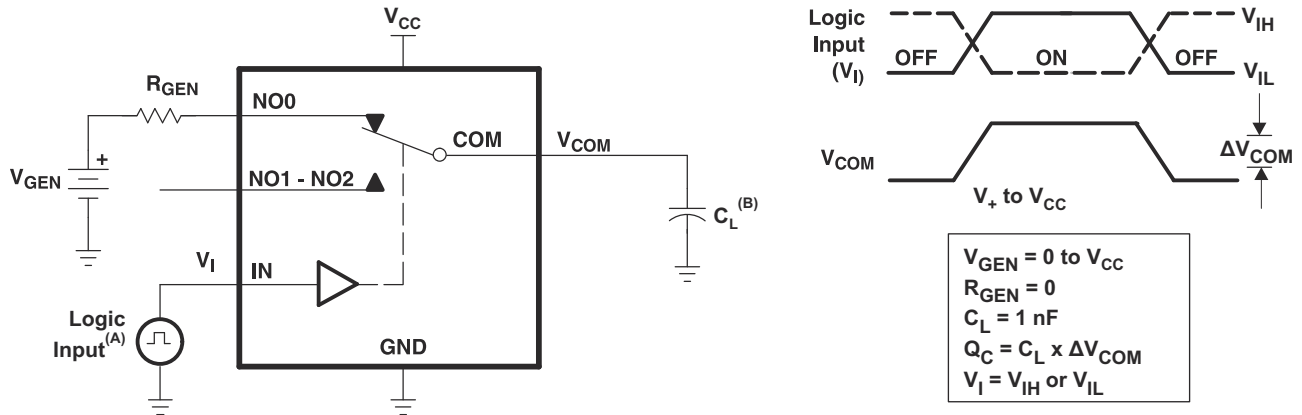

Figure 7-9. Crosstalk (X_{TALK})

Channel ON: NO0 to COM
 Channel OFF: NO0-NO1 to COM
 $V_I = V_{CC}$ or GND

Network Analyzer Setup
 Source Power = 0 dBm
 (632-mV P-P at 50-Ω load)
 DC Bias = 350 mV



- A. All input pulses are supplied by generators having the following characteristics: PRR \leq 10 MHz, $Z_O = 50 \Omega$, $t_r < 5$ ns, $t_f < 5$ ns.
 B. C_L includes probe and jig capacitance.

Figure 7-10. Charge Injection (Q_C)

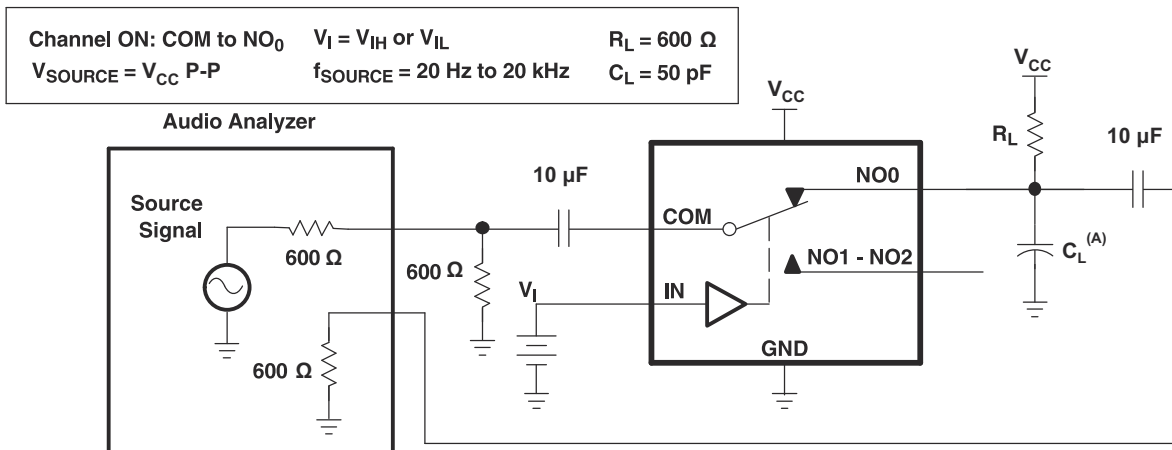

- A. C_L includes probe and jig capacitance.

Figure 7-11. Total Harmonic Distortion (THD)

Table 7-1. Parameter Description

SYMBOL	DESCRIPTION
V_{COM}	Voltage at COM
V_{NO}	Voltage at NO
r_{on}	Resistance between COM and NC or COM and NO ports when the channel is ON
r_{peak}	Peak ON-state resistance over a specified voltage range
Δr_{on}	Difference of r_{on} between channels in a specific device
$r_{on(Flat)}$	Difference between the maximum and minimum value of r_{on} in a channel over the specified range of conditions
$I_{NO(OFF)}$	Leakage current measured at the NO port, with the corresponding channel (NO to COM) in the OFF state
$I_{NO(PWROFF)}$	Leakage current measured at the NO port during the power-down condition, $V_{CC} = 0$.
$I_{NO(ON)}$	Leakage current measured at the NO port, with the corresponding channel (NO to COM) in the ON state and the output (COM) open
$I_{COM(ON)}$	Leakage current measured at the COM port, with the corresponding channel (COM to NO or COM to NC) in the ON state and the output (NC or NO) open
$I_{COM(OFF)}$	Leakage current measured at the COM port during the power-down condition, $V_{CC} = 0$
$I_{COM(PWROFF)}$	Leakage current measured at the COM port during the power-down condition, $V_{CC} = 0$.
V_{IH}	Minimum input voltage for logic high for the control input (IN)
V_{IL}	Maximum input voltage for logic low for the control input (IN)
V_I	Voltage at the control input (IN)
I_{IH}, I_{IL}	Leakage current measured at the control input (IN)
t_{ON}	Turnon time for the switch. This parameter is measured under the specified range of conditions and by the propagation delay between the digital control (IN) signal and analog output (COM or NO) signal when the switch is turning ON.
t_{OFF}	Turnoff time for the switch. This parameter is measured under the specified range of conditions and by the propagation delay between the digital control (IN) signal and analog output (COM or NO) signal when the switch is turning OFF.
t_{BBM}	Break-before-make time. This parameter is measured under the specified range of conditions and by the propagation delay between the output of two adjacent analog channels (NC and NO) when the control signal changes state.
Q_C	Charge injection is a measurement of unwanted signal coupling from the control (IN) input to the analog (NO or COM) output. This is measured in coulomb (C) and measured by the total charge induced due to switching of the control input. Charge injection, $Q_C = C_L \times \Delta V_{COM}$, C_L is the load capacitance and ΔV_{COM} is the change in analog output voltage.
$C_{NO(OFF)}$	Capacitance at the NO port when the corresponding channel (NO to COM) is OFF
$C_{NO(ON)}$	Capacitance at the NO port when the corresponding channel (NO to COM) is ON
$C_{COM(ON)}$	Capacitance at the COM port when the corresponding channel (COM to NO) is ON
$C_{COM(OFF)}$	Capacitance at the COM port when the corresponding channel (COM to NO) is OFF
C_I	Capacitance of control input (IN)
O_{ISO}	OFF isolation of the switch is a measurement of OFF-state switch impedance. This is measured in dB in a specific frequency, with the corresponding channel (NC to COM or NO to COM) in the OFF state.
X_{TALK}	Crosstalk is a measurement of unwanted signal coupling from an ON channel to an OFF channel (NC to NO or NO to NC). This is measured in a specific frequency and in dB.
BW	Bandwidth of the switch. This is the frequency in which the gain of an ON channel is –3 dB less than the DC gain.
THD	Total harmonic distortion describes the signal distortion caused by the analog switch. This is defined as the ratio of root mean square (RMS) value of the second, third, and higher harmonic to the absolute magnitude of the fundamental harmonic.
I_{CC}	Static power-supply current with the control (IN) pin at V_{CC} or GND

Table 7-2. Summary of Characteristics⁽¹⁾

PARAMETER	CHARACTERISTIC
Configuration	Triple 3:1 Multiplexer/ Demultiplexer (1 × SP3T)
Number of channels	1
ON-state resistance (r_{on})	1.1 Ω
ON-state resistance match (Δr_{on})	0.1 Ω
ON-state resistance flatness ($r_{on(flat)}$)	0.15 Ω
Turnon/turnoff time (t_{ON}/t_{OFF})	40 ns/35 ns
Break-before-make time (t_{BBM})	1 ns
Charge injection (Q_C)	40 pC
Bandwidth (BW)	100 MHz
OFF isolation (O_{ISO})	-65 dB at 10 MHz
Crosstalk (X_{TALK})	-66 dB at 10 MHz
Total harmonic distortion (THD)	0.01%
Leakage current ($I_{COM(OFF)}/I_{NO(OFF)}$)	$\pm 20 \mu A$
Power supply current (I_{CC})	0.1 μA
Package options	8-pin DCU or YZP

(1) $V_{CC} = 5 V$, $T_A = 25^\circ C$

8 Detailed Description

8.1 Overview

The TS5A3359 is a bidirectional, single-channel, single-pole triple-throw (SP3T) analog switch that is designed to operate from 1.65 V to 5.5 V. This device provides a signal switching solution while maintaining excellent signal integrity, which makes the TS5A3359 suitable for a wide range of applications in various markets including personal electronics, portable instrumentation, and test and measurement equipment. The device maintains the signal integrity by its low ON-state resistance, excellent ON-state resistance matching, and total harmonic distortion (THD) performance. To prevent signal distortion during the transferring of a signal from one channel to another, the TS5A3359 device also has a specified break-before-make feature. The device consumes very low power and provides isolation when $V_{CC} = 0$.

8.2 Functional Block Diagram

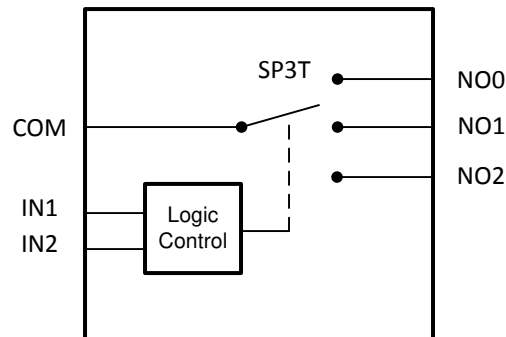

8.3 Feature Description

Isolation in Power-Down Mode, $V_{CC} = 0$

When power is not supplied to the VCC pin, $V_{CC} = 0$, the signal paths NO and COM are high impedance. This is specified in the electrical characteristics table under the COM and NO OFF leakage current when $V_{CC} = 0$. Because the device is high impedance when it is not powered, you may connect other signals to the signal chain without interference of the TS5A3359.

8.4 Device Functional Modes

Table 8-1. Function Table

IN2	IN1	COM TO NO, NO TO COM
L	L	OFF
L	H	COM = NO0
H	L	COM = NO1
H	H	COM = NO2

9 Application and Implementation

Note

Information in the following applications sections is not part of the TI component specification, and TI does not warrant its accuracy or completeness. TI's customers are responsible for determining suitability of components for their purposes, as well as validating and testing their design implementation to confirm system functionality.

9.1 Application Information

The TS5A3359 switch is bidirectional, so the NO and COM pins can be used as either inputs or outputs. This switch is typically used when there is only one signal path that needs to be able to communicate to 3 different signal paths.

9.2 Typical Application

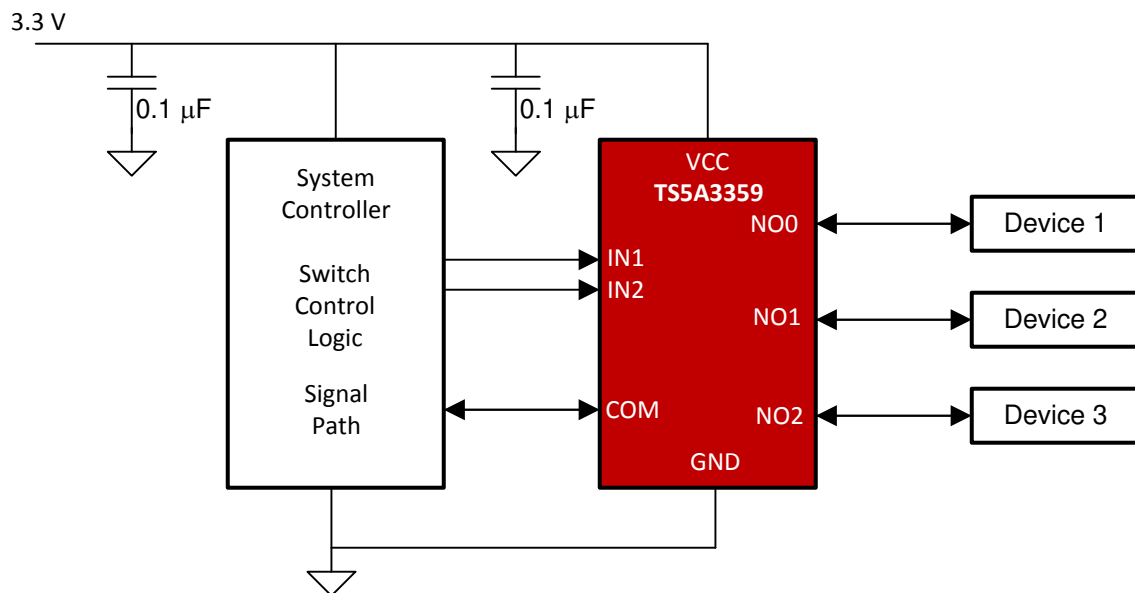

Figure 9-1. Typical Application Schematic

9.2.1 Design Requirements

The TS5A3359 device can be properly operated without any external components. However, TI recommends connecting unused pins to ground through a 50-Ω resistor to prevent signal reflections back into the device. TI also recommends pulling up the digital control pins (IN1 and IN2) to V_{CC} or pulling down to GND to avoid undesired switch positions that could result from the floating pin.

Select the appropriate supply voltage to cover the entire voltage swing of the signal passing through the switch because the TS5A3359 input and output signal swing through NO and COM are dependent on the supply voltage V_{CC}. For example, if the desired signal level to pass through the switch is 5 V, V_{CC} must be greater than or equal to 5 V. V_{CC} = 3.3 V would not be valid for passing a 5-V signal since the Analog signal voltage cannot exceed the supply.

9.2.2 Detailed Design Procedure

The TS5A3359 device can be properly operated without any external components. However, TI recommends connecting unused pins to ground through a 50-Ω resistor to prevent signal reflections back into the device. TI also recommends pulling up the digital control pins (IN1 and IN2) to VCC or pulling down to GND to avoid undesired switch positions that could result from the floating pin.

Select the appropriate supply voltage to cover the entire voltage swing of the signal passing through the switch because the TS5A3359 input/output signal swing through NO and COM are dependant of the supply voltage V_{CC} .

9.2.3 Application Curve

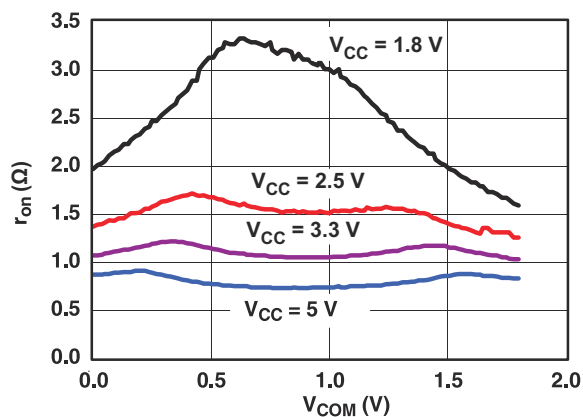

Figure 9-2. R_{on} vs V_{COM}

10 Power Supply Recommendations

TI recommends proper power-supply sequencing for all CMOS devices. Do not exceed the absolute maximum ratings, because stresses beyond the listed ratings can cause permanent damage to the device. Always sequence VCC on first, followed by NO or COM.

Although it is not required, power-supply bypassing improves noise margin and prevents switching noise propagation from the VCC supply to other components. A 0.1-μF capacitor, connected from VCC to GND, is adequate for most applications.

11 Layout

11.1 Layout Guidelines

TI recommends following common printed-circuit board layout guidelines to ensure reliability of the device.

- Bypass capacitors should be used on power supplies.
- Short trace lengths should be used to avoid excessive loading.

11.2 Layout Example

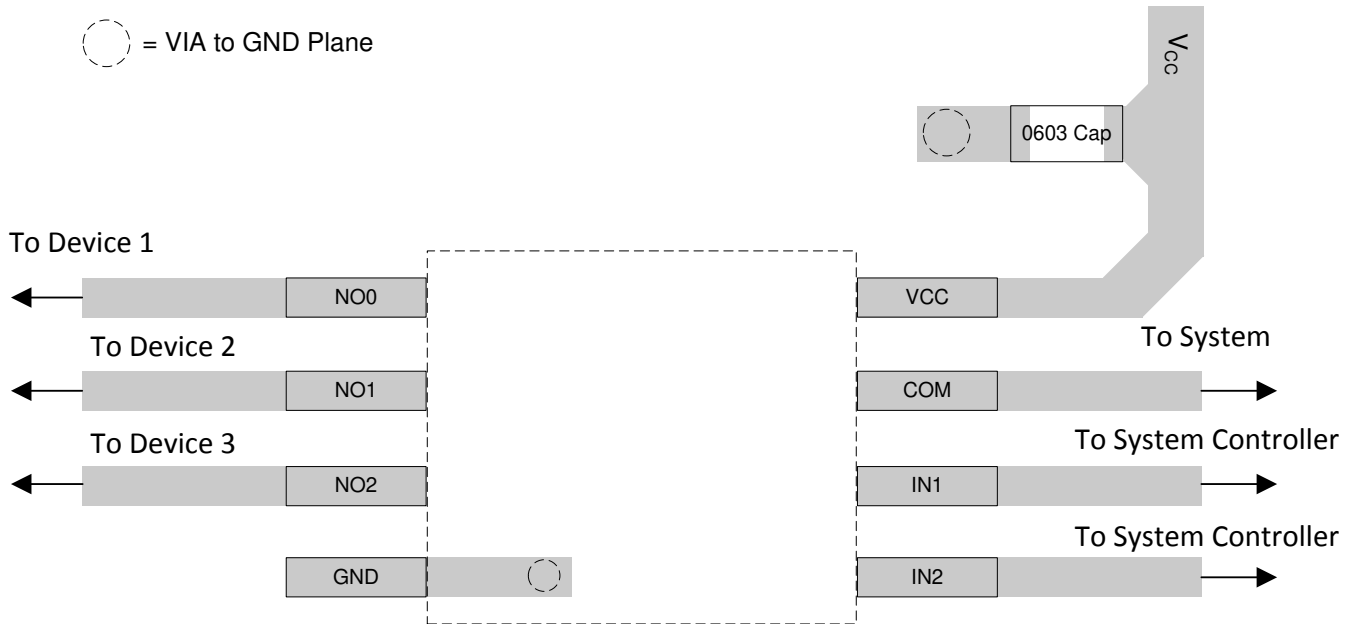

Figure 11-1. Recommended Layout

12 Device and Documentation Support

12.1 Receiving Notification of Documentation Updates

To receive notification of documentation updates, navigate to the device product folder on ti.com. Click on *Subscribe to updates* to register and receive a weekly digest of any product information that has changed. For change details, review the revision history included in any revised document.

12.2 Support Resources

TI E2E™ [support forums](#) are an engineer's go-to source for fast, verified answers and design help — straight from the experts. Search existing answers or ask your own question to get the quick design help you need.

Linked content is provided "AS IS" by the respective contributors. They do not constitute TI specifications and do not necessarily reflect TI's views; see TI's [Terms of Use](#).

12.3 Trademarks

TI E2E™ is a trademark of Texas Instruments.

All trademarks are the property of their respective owners.

12.4 Electrostatic Discharge Caution



This integrated circuit can be damaged by ESD. Texas Instruments recommends that all integrated circuits be handled with appropriate precautions. Failure to observe proper handling and installation procedures can cause damage.

ESD damage can range from subtle performance degradation to complete device failure. Precision integrated circuits may be more susceptible to damage because very small parametric changes could cause the device not to meet its published specifications.



12.5 Glossary

[TI Glossary](#) This glossary lists and explains terms, acronyms, and definitions.

13 Mechanical, Packaging, and Orderable Information

The following pages include mechanical, packaging, and orderable information. This information is the most current data available for the designated devices. This data is subject to change without notice and revision of this document. For browser-based versions of this data sheet, refer to the left-hand navigation.

PACKAGING INFORMATION

Orderable Device	Status (1)	Package Type	Package Drawing	Pins	Package Qty	Eco Plan (2)	Lead finish/ Ball material (6)	MSL Peak Temp (3)	Op Temp (°C)	Device Marking (4/5)	Samples
TS5A3359DCUR	ACTIVE	VSSOP	DCU	8	3000	RoHS & Green	NIPDAU	Level-1-260C-UNLIM	-40 to 85	(AL, JALR) JZ	
TS5A3359DCUT	LIFEBUY	VSSOP	DCU	8	250	RoHS & Green	NIPDAU	Level-1-260C-UNLIM	-40 to 85	(AL, JALR) JZ	
TS5A3359DCUTG4	LIFEBUY	VSSOP	DCU	8	250	RoHS & Green	NIPDAU	Level-1-260C-UNLIM	-40 to 85	(AL, JALR) JZ	
TS5A3359YZPR	ACTIVE	DSBGA	YZP	8	3000	RoHS & Green	SNAGCU	Level-1-260C-UNLIM	-40 to 85	J9	

(1) The marketing status values are defined as follows:

ACTIVE: Product device recommended for new designs.

LIFEBUY: TI has announced that the device will be discontinued, and a lifetime-buy period is in effect.

NRND: Not recommended for new designs. Device is in production to support existing customers, but TI does not recommend using this part in a new design.

PREVIEW: Device has been announced but is not in production. Samples may or may not be available.

OBSOLETE: TI has discontinued the production of the device.

(2) **RoHS:** TI defines "RoHS" to mean semiconductor products that are compliant with the current EU RoHS requirements for all 10 RoHS substances, including the requirement that RoHS substance do not exceed 0.1% by weight in homogeneous materials. Where designed to be soldered at high temperatures, "RoHS" products are suitable for use in specified lead-free processes. TI may reference these types of products as "Pb-Free".

RoHS Exempt: TI defines "RoHS Exempt" to mean products that contain lead but are compliant with EU RoHS pursuant to a specific EU RoHS exemption.

Green: TI defines "Green" to mean the content of Chlorine (Cl) and Bromine (Br) based flame retardants meet JS709B low halogen requirements of <=1000ppm threshold. Antimony trioxide based flame retardants must also meet the <=1000ppm threshold requirement.

(3) MSL, Peak Temp. - The Moisture Sensitivity Level rating according to the JEDEC industry standard classifications, and peak solder temperature.

(4) There may be additional marking, which relates to the logo, the lot trace code information, or the environmental category on the device.

(5) Multiple Device Markings will be inside parentheses. Only one Device Marking contained in parentheses and separated by a "~" will appear on a device. If a line is indented then it is a continuation of the previous line and the two combined represent the entire Device Marking for that device.

(6) Lead finish/Ball material - Orderable Devices may have multiple material finish options. Finish options are separated by a vertical ruled line. Lead finish/Ball material values may wrap to two lines if the finish value exceeds the maximum column width.

Important Information and Disclaimer: The information provided on this page represents TI's knowledge and belief as of the date that it is provided. TI bases its knowledge and belief on information provided by third parties, and makes no representation or warranty as to the accuracy of such information. Efforts are underway to better integrate information from third parties. TI has taken and

continues to take reasonable steps to provide representative and accurate information but may not have conducted destructive testing or chemical analysis on incoming materials and chemicals. TI and TI suppliers consider certain information to be proprietary, and thus CAS numbers and other limited information may not be available for release.

In no event shall TI's liability arising out of such information exceed the total purchase price of the TI part(s) at issue in this document sold by TI to Customer on an annual basis.

TAPE AND REEL INFORMATION



QUADRANT ASSIGNMENTS FOR PIN 1 ORIENTATION IN TAPE



*All dimensions are nominal

Device	Package Type	Package Drawing	Pins	SPQ	Reel Diameter (mm)	Reel Width W1 (mm)	A0 (mm)	B0 (mm)	K0 (mm)	P1 (mm)	W (mm)	Pin1 Quadrant
TS5A3359DCUR	VSSOP	DCU	8	3000	180.0	8.4	2.25	3.35	1.05	4.0	8.0	Q3
TS5A3359YZPR	DSBGA	YZP	8	3000	180.0	8.4	1.02	2.02	0.63	4.0	8.0	Q1

TAPE AND REEL BOX DIMENSIONS

*All dimensions are nominal

Device	Package Type	Package Drawing	Pins	SPQ	Length (mm)	Width (mm)	Height (mm)
TS5A3359DCUR	VSSOP	DCU	8	3000	202.0	201.0	28.0
TS5A3359YZPR	DSBGA	YZP	8	3000	210.0	185.0	35.0

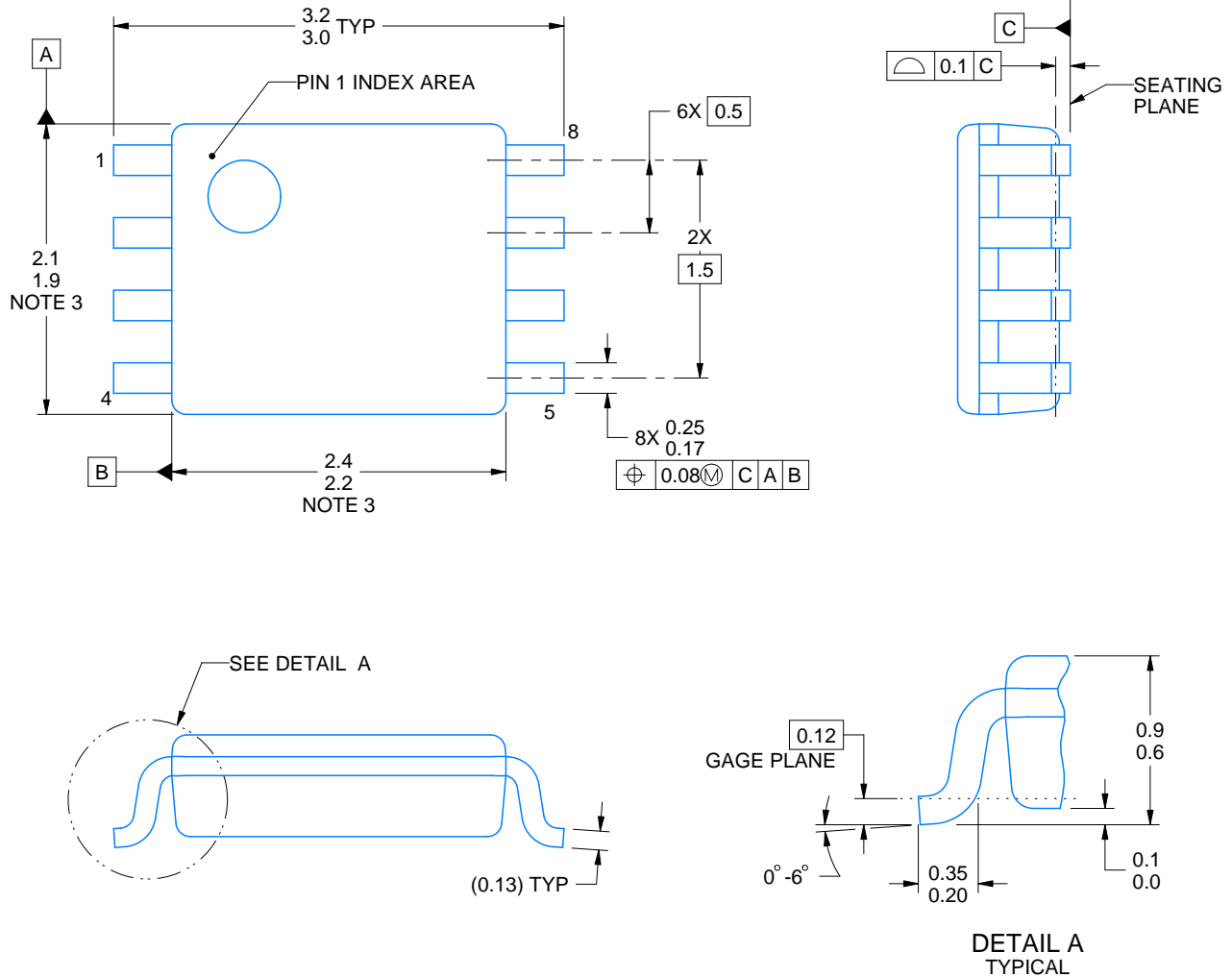

4225266/A 09/2014

NOTES:

1. All linear dimensions are in millimeters. Any dimensions in parenthesis are for reference only. Dimensioning and tolerancing per ASME Y14.5M.
2. This drawing is subject to change without notice.
3. This dimension does not include mold flash, protrusions, or gate burrs. Mold flash, protrusions, or gate burrs shall not exceed 0.15 mm per side.
4. Reference JEDEC registration MO-187 variation CA.

EXAMPLE BOARD LAYOUT

DCU0008A

VSSOP - 0.9 mm max height

SMALL OUTLINE PACKAGE

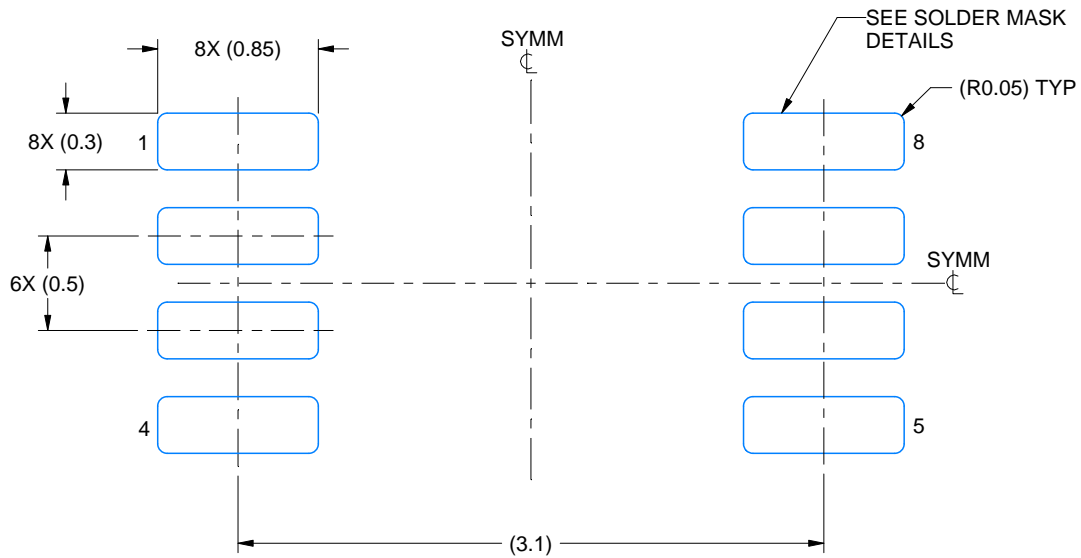

LAND PATTERN EXAMPLE
EXPOSED METAL SHOWN
SCALE: 25X



4225266/A 09/2014

NOTES: (continued)

- 5. Publication IPC-7351 may have alternate designs.
- 6. Solder mask tolerances between and around signal pads can vary based on board fabrication site.

EXAMPLE STENCIL DESIGN

DCU0008A

VSSOP - 0.9 mm max height

SMALL OUTLINE PACKAGE



SOLDER PASTE EXAMPLE
BASED ON 0.125 mm THICK STENCIL
SCALE: 25X

4225266/A 09/2014

NOTES: (continued)

7. Laser cutting apertures with trapezoidal walls and rounded corners may offer better paste release. IPC-7525 may have alternate design recommendations.
8. Board assembly site may have different recommendations for stencil design.

YZP0008

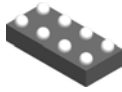

PACKAGE OUTLINE

DSBGA - 0.5 mm max height

DIE SIZE BALL GRID ARRAY

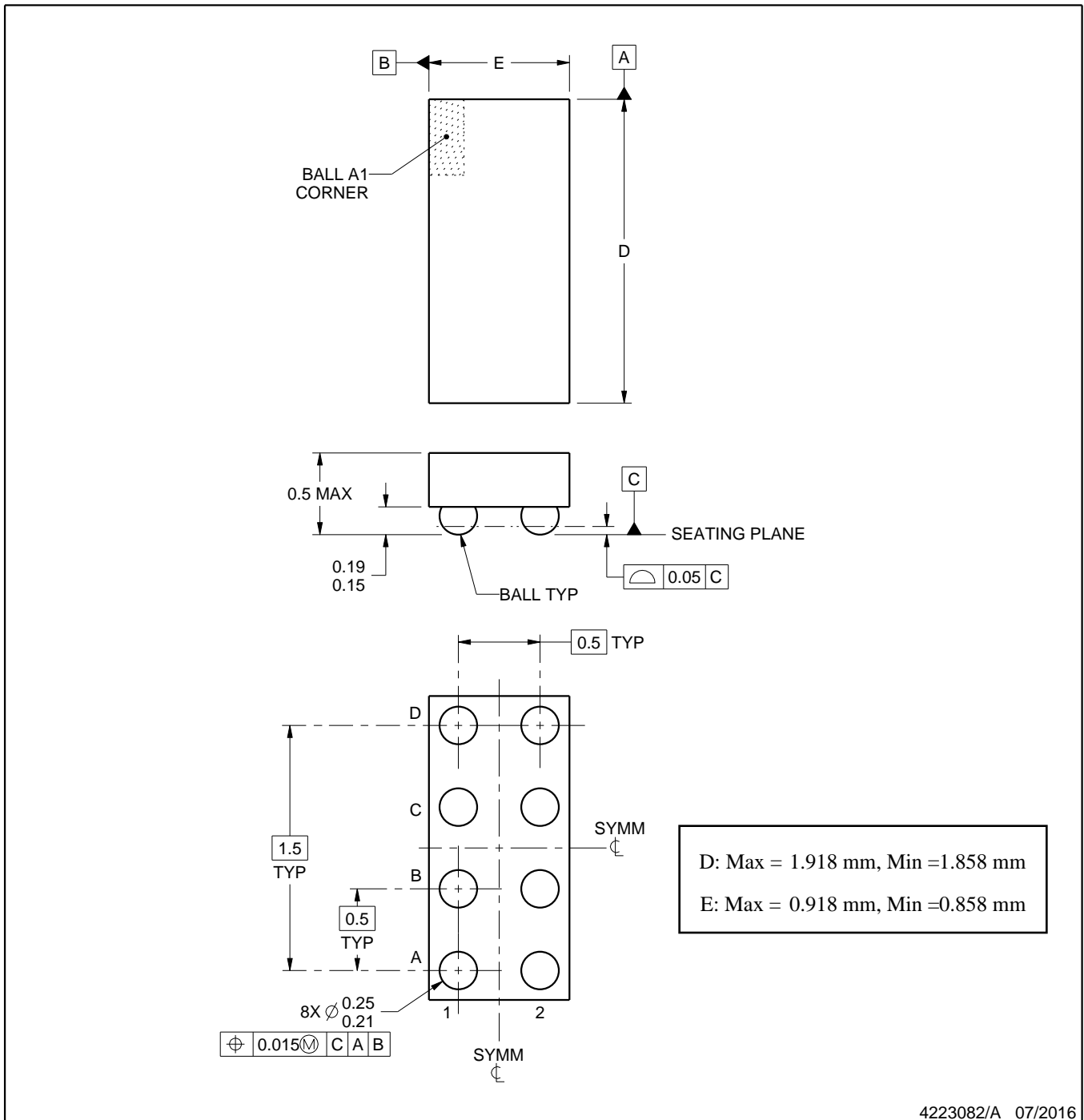

NOTES:

1. All linear dimensions are in millimeters. Any dimensions in parenthesis are for reference only. Dimensioning and tolerancing per ASME Y14.5M.
2. This drawing is subject to change without notice.

EXAMPLE BOARD LAYOUT

YZP0008

DSBGA - 0.5 mm max height

DIE SIZE BALL GRID ARRAY

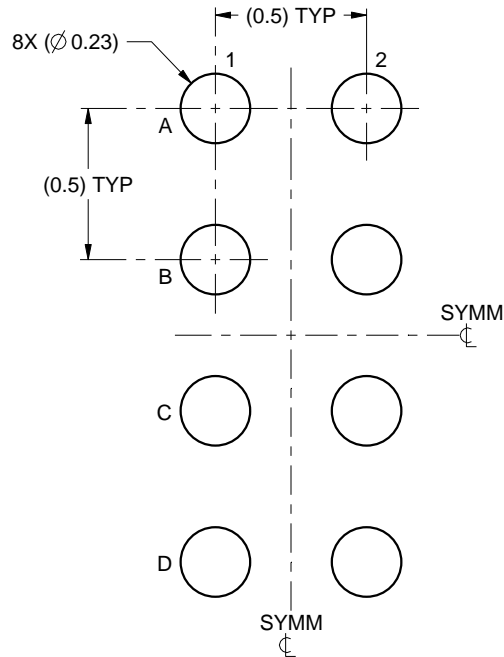

LAND PATTERN EXAMPLE
SCALE:40X

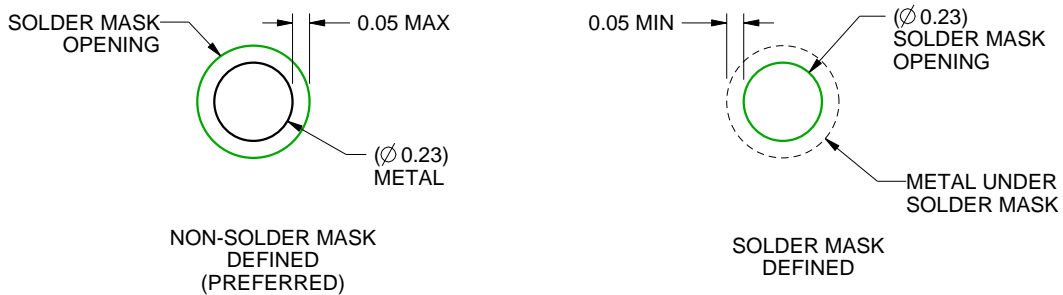

SOLDER MASK DETAILS
NOT TO SCALE

4223082/A 07/2016

NOTES: (continued)

- Final dimensions may vary due to manufacturing tolerance considerations and also routing constraints. For more information, see Texas Instruments literature number SNVA009 (www.ti.com/lit/snva009).

EXAMPLE STENCIL DESIGN

YZP0008

DSBGA - 0.5 mm max height

DIE SIZE BALL GRID ARRAY

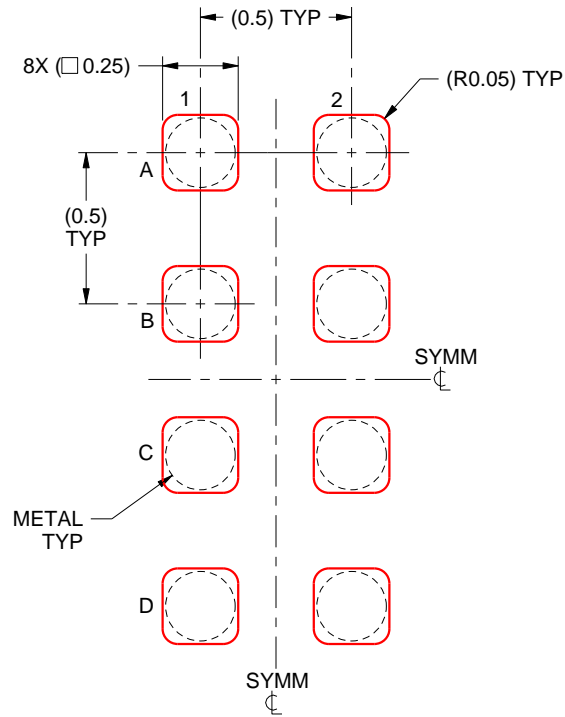

SOLDER PASTE EXAMPLE
BASED ON 0.1 mm THICK STENCIL
SCALE:40X

4223082/A 07/2016

NOTES: (continued)

4. Laser cutting apertures with trapezoidal walls and rounded corners may offer better paste release.

IMPORTANT NOTICE AND DISCLAIMER

TI PROVIDES TECHNICAL AND RELIABILITY DATA (INCLUDING DATA SHEETS), DESIGN RESOURCES (INCLUDING REFERENCE DESIGNS), APPLICATION OR OTHER DESIGN ADVICE, WEB TOOLS, SAFETY INFORMATION, AND OTHER RESOURCES "AS IS" AND WITH ALL FAULTS, AND DISCLAIMS ALL WARRANTIES, EXPRESS AND IMPLIED, INCLUDING WITHOUT LIMITATION ANY IMPLIED WARRANTIES OF MERCHANTABILITY, FITNESS FOR A PARTICULAR PURPOSE OR NON-INFRINGEMENT OF THIRD PARTY INTELLECTUAL PROPERTY RIGHTS.

These resources are intended for skilled developers designing with TI products. You are solely responsible for (1) selecting the appropriate TI products for your application, (2) designing, validating and testing your application, and (3) ensuring your application meets applicable standards, and any other safety, security, regulatory or other requirements.

These resources are subject to change without notice. TI grants you permission to use these resources only for development of an application that uses the TI products described in the resource. Other reproduction and display of these resources is prohibited. No license is granted to any other TI intellectual property right or to any third party intellectual property right. TI disclaims responsibility for, and you will fully indemnify TI and its representatives against, any claims, damages, costs, losses, and liabilities arising out of your use of these resources.

TI's products are provided subject to [TI's Terms of Sale](#) or other applicable terms available either on [ti.com](https://www.ti.com) or provided in conjunction with such TI products. TI's provision of these resources does not expand or otherwise alter TI's applicable warranties or warranty disclaimers for TI products.

TI objects to and rejects any additional or different terms you may have proposed.

Mailing Address: Texas Instruments, Post Office Box 655303, Dallas, Texas 75265
Copyright © 2024, Texas Instruments Incorporated