

10-Rail Sequencer and System Health Monitor With 10-Fan Control

Check for Samples: [UCD90910](#)

FEATURES

- **Monitor and Sequence Ten Voltage Rails**
 - All Rails Sampled Every 400 μ s
 - 12-Bit ADC With 2.5-V, 0.5% Internal V_{REF}
 - Sequence Based on Time, Rail and Pin Dependencies
 - Four Programmable Undervoltage and Overvoltage Thresholds per Monitor
- **Fan Control and Monitoring**
 - Supports Ten Fans With Five User-Defined Speed-vs-Temperature Setpoints
 - Supports Two-, Three-, and Four-Wire Fans
- **Nonvolatile Error and Peak-Value Logging per Monitor (up to 12 Faults)**
- **Closed-Loop Margining for Ten Rails**
 - Margin Output Adjusts Rail Voltage to Match User-Defined Margin Thresholds
- **Programmable Watchdog Timer and System Reset**
- **Flexible Digital I/O Configuration**
- **Multiphase PWM Clock Generator**
 - Clock Frequencies From 15.259 kHz to 125 MHz
 - Capability to Configure Independent Clock Outputs for Synchronizing Switch-Mode Power Supplies
- **Internal Temperature Sensor**
- **JTAG and I²C™ / SMBus / PMBus Interfaces**
- **Full Configuration Update while in Normal Mode Capability**

APPLICATIONS

- **Industrial / ATE**
- **Telecommunications and Networking Equipment**
- **Servers and Storage Systems**
- **Any System Requiring Sequencing and Monitoring of Multiple Power Rails**

DESCRIPTION

The UCD90910 is a ten-rail I²C / PMBus addressable power-supply sequencer and system-health monitor. The device integrates a 12-bit ADC for monitoring up to 13 power-supply voltage, current, or temperature inputs.

Twenty-six GPIO pins can be used for power-supply enables, power-on-reset signals, external interrupts, cascading, or other system functions. Twelve of these pins offer PWM functionality. Using these pins, the UCD90910 offers support for fan control, margining, and general-purpose PWM functions.

Fan-control signals can be sent using PMBus commands or generated from one of two built-in fan-control algorithms. PWM outputs combined with temperature and fan-speed measurements provide a complete fan-control solution for up to ten independent fans.

The TI Fusion Digital Power™ designer software is provided for device configuration. This PC-based graphical user interface (GUI) offers an intuitive interface for configuring, storing, and monitoring all system operating parameters.

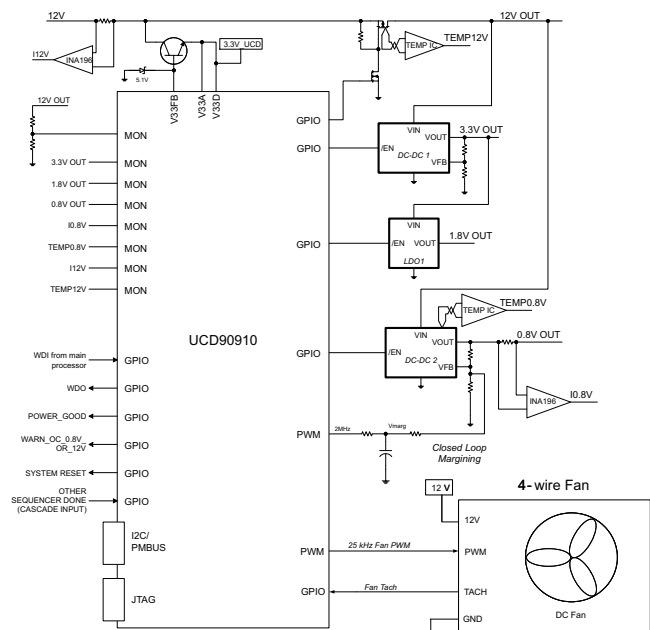

Please be aware that an important notice concerning availability, standard warranty, and use in critical applications of Texas Instruments semiconductor products and disclaimers thereto appears at the end of this data sheet.

Fusion Digital Power is a trademark of Texas Instruments.

I²C is a trademark of NXP B.V.

UCD90910

SLVSA81 –JULY 2010

www.ti.com

This integrated circuit can be damaged by ESD. Texas Instruments recommends that all integrated circuits be handled with appropriate precautions. Failure to observe proper handling and installation procedures can cause damage.

ESD damage can range from subtle performance degradation to complete device failure. Precision integrated circuits may be more susceptible to damage because very small parametric changes could cause the device not to meet its published specifications.

FUNCTIONAL BLOCK DIAGRAM

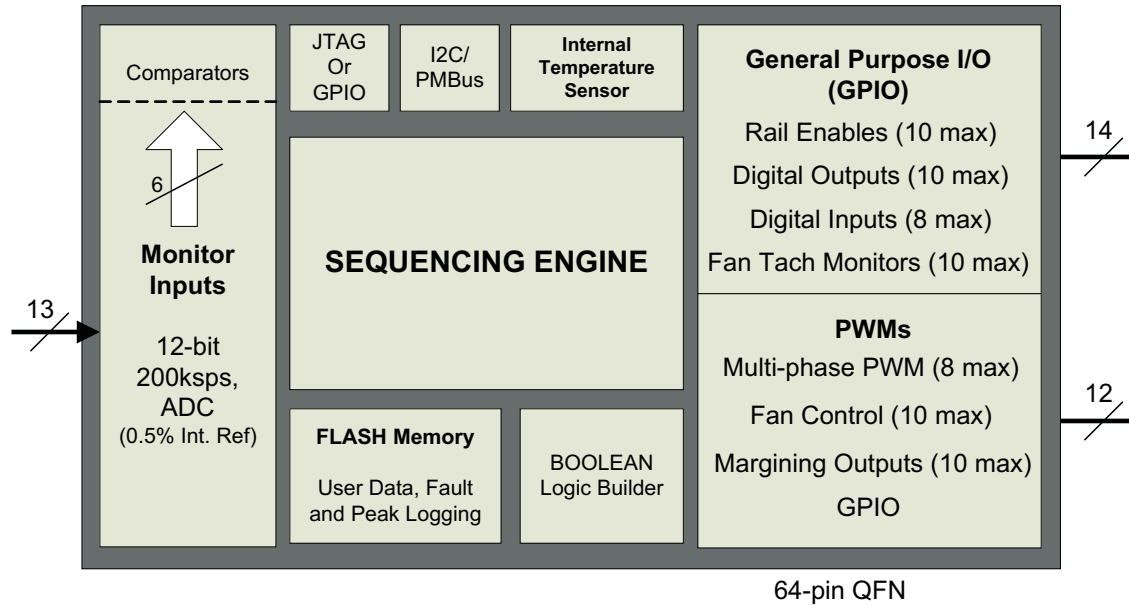

ORDERING INFORMATION

For the most current package and ordering information, see the Package Option Addendum at the end of this document, or see the TI Web site at www.ti.com.

ABSOLUTE MAXIMUM RATINGS⁽¹⁾

		VALUE	UNIT
Voltage applied at V33D to DV _{SS}		-0.3 to 3.8	V
Voltage applied at V33A to AV _{SS}		-0.3 to 3.8	V
Voltage applied at V33FB to AV _{SS}		-0.3 to 5.5	V
Voltage applied to any other pin ⁽²⁾		-0.3 to (V33A + 0.3)	V
Storage temperature (T _{stg})		-40 to 150	°C
ESD rating	Human-body model (HBM)	2.5	kV
	Charged-device model (CDM)	750	V

(1) Stresses beyond those listed under *Absolute Maximum Ratings* may cause permanent damage to the device. These are stress ratings only and functional operation of the device at these or any other conditions beyond those indicated under *Recommended Operating Conditions* is not implied. Exposure to absolute-maximum-rated conditions for extended periods may affect device reliability.

(2) All voltages referenced to V_{SS}

THERMAL INFORMATION

THERMAL METRIC ⁽¹⁾		UCD90910	UNITS
		RGC	
		64 PINS	
θ_{JA}	Junction-to-ambient thermal resistance ⁽²⁾	26.4	°C/W
θ_{JcTop}	Junction-to-case (top) thermal resistance ⁽³⁾	21.2	
θ_{JB}	Junction-to-board thermal resistance ⁽⁴⁾	1.7	
ψ_{JT}	Junction-to-top characterization parameter ⁽⁵⁾	0.7	
ψ_{JB}	Junction-to-board characterization parameter ⁽⁶⁾	8.8	
θ_{JcBot}	Junction-to-case (bottom) thermal resistance ⁽⁷⁾	1.7	

- (1) For more information about traditional and new thermal metrics, see the *IC Package Thermal Metrics* application report, [SPRA953](#).
- (2) The junction-to-ambient thermal resistance under natural convection is obtained in a simulation on a JEDEC-standard, high-K board, as specified in JESD51-7, in an environment described in JESD51-2a.
- (3) The junction-to-case (top) thermal resistance is obtained by simulating a cold plate test on the package top. No specific JEDEC-standard test exists, but a close description can be found in the ANSI SEMI standard G30-88.
- (4) The junction-to-board thermal resistance is obtained by simulating in an environment with a ring cold plate fixture to control the PCB temperature, as described in JESD51-8.
- (5) The junction-to-top characterization parameter, ψ_{JT} , estimates the junction temperature of a device in a real system and is extracted from the simulation data for obtaining θ_{JA} , using a procedure described in JESD51-2a (sections 6 and 7).
- (6) The junction-to-board characterization parameter, ψ_{JB} , estimates the junction temperature of a device in a real system and is extracted from the simulation data for obtaining θ_{JA} , using a procedure described in JESD51-2a (sections 6 and 7).
- (7) The junction-to-case (bottom) thermal resistance is obtained by simulating a cold plate test on the exposed (power) pad. No specific JEDEC standard test exists, but a close description can be found in the ANSI SEMI standard G30-88.

RECOMMENDED OPERATING CONDITIONS

	MIN	NOM	MAX	UNIT
Supply voltage during operation (V_{33D} , V_{33DIO} , V_{33A})	3	3.3	3.6	V
Operating free-air temperature range, T_A	-40		110	°C
Junction temperature, T_J			125	°C

ELECTRICAL CHARACTERISTICS

over operating free-air temperature range (unless otherwise noted)

PARAMETER		TEST CONDITIONS	MIN	NOM	MAX	UNIT
SUPPLY CURRENT						
I_{V33A}	Supply current ⁽¹⁾	$V_{V33A} = 3.3\text{ V}$		8		mA
I_{V33DIO}		$V_{V33DIO} = 3.3\text{ V}$		2		mA
I_{V33D}		$V_{V33D} = 3.3\text{ V}$		40		mA
I_{V33D}		$V_{V33D} = 3.3\text{ V}$, storing configuration parameters in flash memory			50	
INTERNAL REGULATOR CONTROLLER INPUTS/OUTPUTS						
V_{V33}	3.3-V linear regulator	Emitter of NPN transistor	3.25	3.3	3.35	V
V_{V33FB}	3.3-V linear reg feedback			4	4.6	V
I_{V33FB}	Series pass base drive	$V_{VIN} = 12\text{ V}$		10		mA
Beta	Series NPN pass device		40			
EXTERNALLY SUPPLIED 3.3V POWER						
V_{V33D} , V_{V33DIO}	Digital 3.3-V power	$T_A = 25^\circ\text{C}$		3	3.6	V
V_{V33A}	Analog 3.3-V power	$T_A = 25^\circ\text{C}$		3	3.6	V
ANALOG INPUTS (MON1–MON13)						
V_{MON}	Input voltage range	MON1–MON9		0	2.5	V
		MON10–MON13		0.2	2.5	V
INL	ADC integral nonlinearity		–2.5		2.5	mV
I_{IKG}	Input leakage current	3 V applied to pin			100	nA
I_{OFFSET}	Input offset current	1-k Ω source impedance	–5		5	μA
R_{IN}	Input impedance	MON1–MON9, ground reference		8		M Ω
		MON10–MON13, ground reference		0.5	1.5	3
C_{IN}	Input capacitance				10	pF
$t_{CONVERT}$	ADC sample period	14 voltages sampled, 3.89 $\mu\text{s}/\text{sample}$		400		μs
V_{REF}	ADC 2.5 V, internal Reference accuracy	0 $^\circ\text{C}$ to 125 $^\circ\text{C}$	–0.5%		0.5%	
		–40 $^\circ\text{C}$ to 125 $^\circ\text{C}$	–1%		1%	
ANALOG INPUT (PMBUS_ADDRx, INTERNAL TEMP SENSE)						
I_{BIAS}	Bias current for PMBus addr. pins			9	11	μA
V_{ADDR_OPEN}	Voltage – open pin	PMBUS_ADDR0, PMBUS_ADDR1 open		2.26		V
V_{ADDR_SHORT}	Voltage – shorted pin	PMBUS_ADDR0, PMBUS_ADDR1 short to ground			0.124	V
$T_{Internal}$	Internal temperature-sense accuracy	Over range from 0 $^\circ\text{C}$ to 100 $^\circ\text{C}$	–5		5	$^\circ\text{C}$
DIGITAL INPUTS AND OUTPUTS						
V_{OL}	Low-level output voltage	$I_{OL} = 6\text{ mA}^{(2)}$, $V_{33DIO} = 3\text{ V}$			Dgnd + 0.25	V
V_{OH}	High-level output voltage	$I_{OH} = -6\text{ mA}^{(3)}$, $V_{33DIO} = 3\text{ V}$	$V_{33DIO} - 0.6$			V
V_{IH}	High-level input voltage	$V_{33DIO} = 3\text{ V}$		2.1	3.6	V
V_{IL}	Low-level input voltage	$V_{33DIO} = 3.5\text{ V}$			1.4	V

(1) Typical supply current values are based on device programmed but not configured, and no peripherals connected to any pins.

 (2) The maximum total current I_{OLmax} , for all outputs combined, should not exceed 12 mA to hold the maximum voltage drop specified.

 (3) The maximum total current, I_{OHmax} , for all outputs combined, should not exceed 48 mA to hold the maximum voltage drop specified.

ELECTRICAL CHARACTERISTICS (continued)

over operating free-air temperature range (unless otherwise noted)

PARAMETER		TEST CONDITIONS	MIN	NOM	MAX	UNIT
FAN CONTROL INPUTS AND OUTPUTS						
T _{PWM_FREQ}	FAN-PWM frequency	FPWM1-8	15.260		125000	kHz
		PWM1		10		
		PWM2		1		
		PWM3-4	0.001		7800	
DUTY _{PWM}	FAN-PWM duty cycle range		0		100	%
Tach _{RANGE}	FAN-TACH range	For 1 Tach pulse per revolution. At 2, 3 or 4 pulse/rev, divide by the value	30		300k	RPM
Tach _{RES}	FAN-TACH resolution	For 1 Tach pulse per revolution		30		RPM
t _{MIN}	FAN-TACH minimum pulse width	Either positive or negative polarity	200			µs
MARGINING OUTPUTS						
T _{PWM_FREQ}	MARGINING-PWM frequency	FPWM1-8	15.260		125000	kHz
		PWM3-4	0.001		7800	
DUTY _{PWM}	FAN-PWM duty cycle range		0		100	%
SYSTEM PERFORMANCE						
V _{DD} Slew	Minimum V _{DD} slew rate	V _{DD} slew rate between 2.3 V and 2.9 V	0.25			V/ms
V _{RESET}	Supply voltage at which device comes out of reset	For power-on reset (POR)			2.4	V
t _{RESET}	Low-pulse duration needed at RESET pin	To reset device during normal operation	2			µS
f(PCLK)	Internal oscillator frequency	T _A = 125°C, T _A = 25°C	240	250	260	MHz
t _{retention}	Retention of configuration parameters	T _J = 25°C	100			Years
Write_Cycles	Number of nonvolatile erase/write cycles	T _J = 25°C	20			K cycles

I²C / SMBus / PMBus

The timing characteristics and timing diagram for the communications interface that supports I²C, SMBus, and PMBus are shown as follows.

I²C / SMBus / PMBus TIMING REQUIREMENTS

T_A = -40°C to 85°C, 3 V < V_{DD} < 3.6 V; typical values at T_A = 25°C and V_{CC} = 2.5 V (unless otherwise noted)

PARAMETER		TEST CONDITIONS	MIN	TYP	MAX	UNIT
FSMB	SMBus/PMBus operating frequency	Slave mode, SMBC 50% duty cycle	10		400	kHz
FI2C	I ² C operating frequency	Slave mode, SCL 50% duty cycle	10		400	kHz
t _(BUF)	Bus free time between start and stop		4.7			μs
t _(HD:STA)	Hold time after (repeated) start		0.26			μs
t _(SU:STA)	Repeated-start setup time		0.26			μs
t _(SU:STO)	Stop setup time		0.26			μs
t _(HD:DAT)	Data hold time	Receive mode	0			ns
t _(SU:DAT)	Data setup time		50			ns
t _(TIMEOUT)	Error signal/detect	See (1)			35	ms
t _(LOW)	Clock low period		0.5			μs
t _(HIGH)	Clock high period	See (2)	0.26		50	μs
t _(LOW:SEXT)	Cumulative clock low slave extend time	See (3)			25	ms
t _f	Clock/data fall time	See (4)			120	ns
t _r	Clock/data rise time	See (5)			120	ns

- (1) The device times out when any clock low exceeds t_(TIMEOUT).
- (2) t_(HIGH), Max, is the minimum bus idle time. SMBC = SMBD = 1 for t > 50 ms causes reset of any transaction that is in progress. This specification is valid when the NC_SMB control bit remains in the default cleared state (CLK[0] = 0).
- (3) t_(LOW:SEXT) is the cumulative time a slave device is allowed to extend the clock cycles in one message from initial start to the stop.
- (4) Fall time t_f = 0.9 V_{DD} to (V_{IL}MAX - 0.15)
- (5) Rise time t_r = (V_{IL}MAX - 0.15) to (V_{IH}MIN + 0.15)

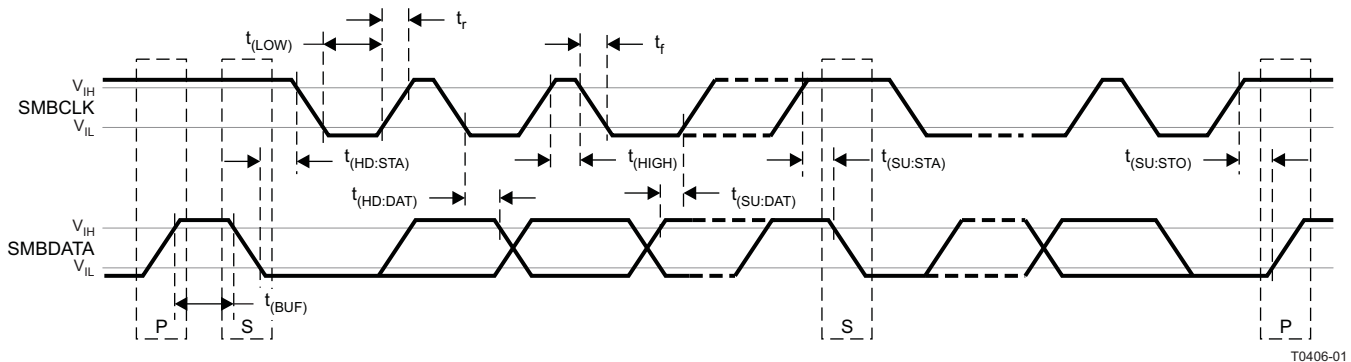

Figure 1. I²C / SMBus Timing Diagram

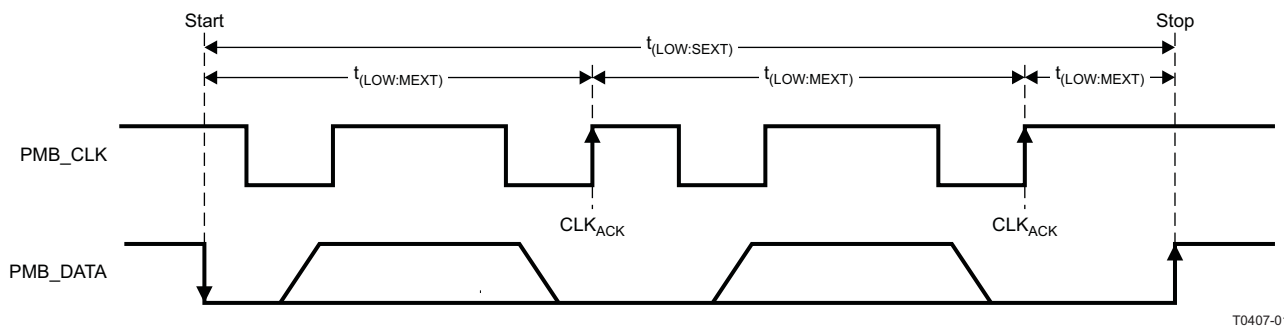
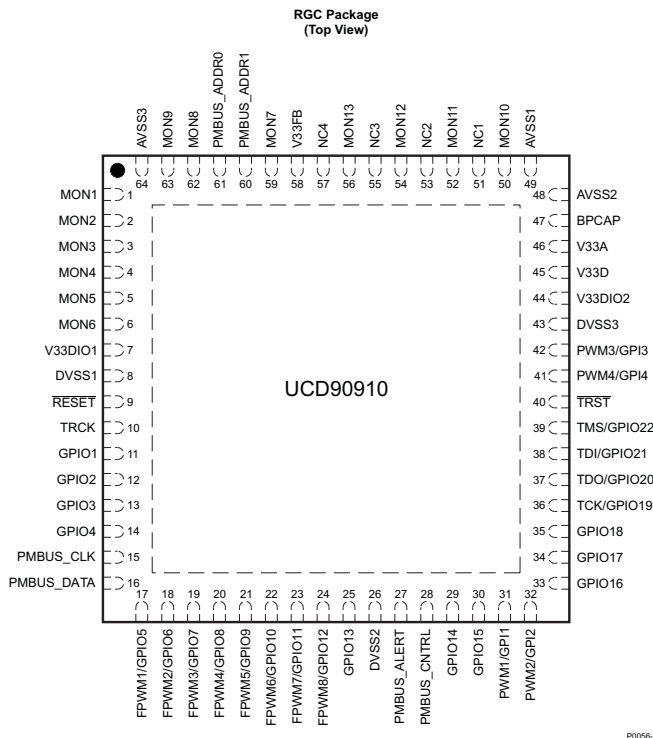
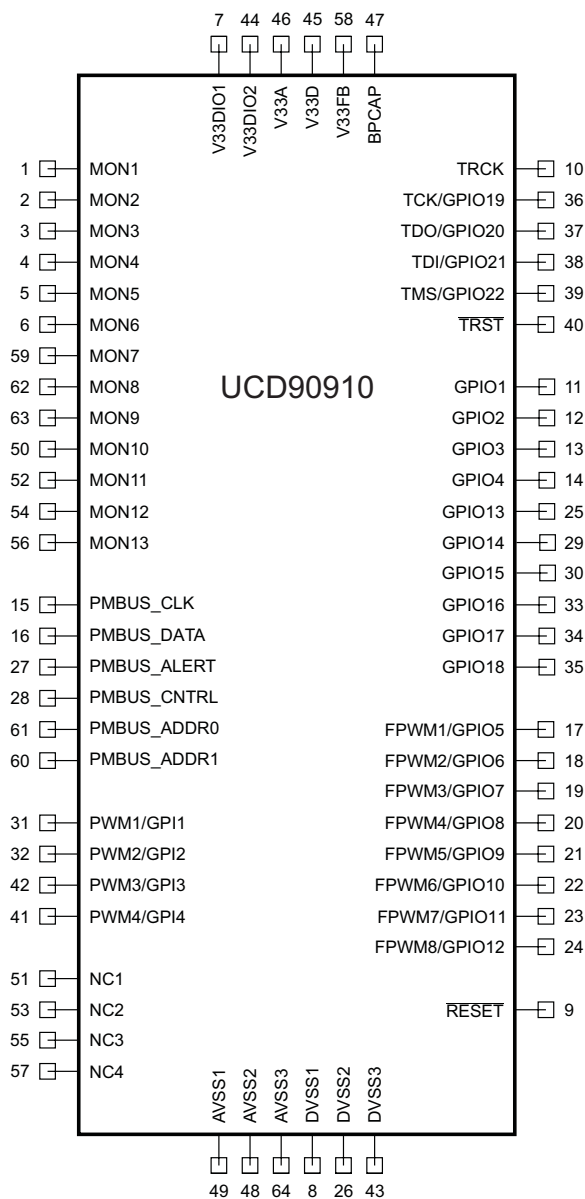

Figure 2. Bus Timing in Extended Mode

DEVICE INFORMATION

UCD90910 PIN ASSIGNMENT



M0178-01

Table 1. PIN FUNCTIONS

PIN NAME	PIN NO.	I/O TYPE	DESCRIPTION
ANALOG MONITOR INPUTS			
MON1	1	I	Analog input (0 V–2.5 V)
MON2	2	I	Analog input (0 V–2.5 V)
MON3	3	I	Analog input (0 V–2.5 V)
MON4	4	I	Analog input (0 V–2.5 V)
MON5	5	I	Analog input (0 V–2.5 V)
MON6	6	I	Analog input (0 V–2.5 V)
MON7	59	I	Analog input (0 V–2.5 V)

Table 1. PIN FUNCTIONS (continued)

PIN NAME	PIN NO.	I/O TYPE	DESCRIPTION
MON8	62	I	Analog input (0 V–2.5 V)
MON9	63	I	Analog input (0 V–2.5 V)
MON10	50	I	Analog input (0.2 V–2.5 V)
MON11	52	I	Analog input (0.2 V–2.5 V)
MON12	54	I	Analog input (0.2 V–2.5 V)
MON13	56	I	Analog input (0.2 V–2.5 V)
GPIO			
GPIO1	11	I/O	General-purpose discrete I/O
GPIO2	12	I/O	General-purpose discrete I/O
GPIO3	13	I/O	General-purpose discrete I/O
GPIO4	14	I/O	General-purpose discrete I/O
GPIO13	25	I/O	General-purpose discrete I/O
GPIO14	29	I/O	General-purpose discrete I/O
GPIO15	30	I/O	General-purpose discrete I/O
GPIO16	33	I/O	General-purpose discrete I/O
GPIO17	34	I/O	General-purpose discrete I/O
GPIO18	35	I/O	General-purpose discrete I/O
PWM OUTPUTS			
FPWM1/GPIO5	17	I/O/PWM	PWM (15.259 kHz to 125 MHz) or GPIO
FPWM2/GPIO6	18	I/O/PWM	PWM (15.259 kHz to 125 MHz) or GPIO
FPWM3/GPIO7	19	I/O/PWM	PWM (15.259 kHz to 125 MHz) or GPIO
FPWM4/GPIO8	20	I/O/PWM	PWM (15.259 kHz to 125 MHz) or GPIO
FPWM5/GPIO9	21	I/O/PWM	PWM (15.259 kHz to 125 MHz) or GPIO
FPWM6/GPIO10	22	I/O/PWM	PWM (15.259 kHz to 125 MHz) or GPIO
FPWM7/GPIO11	23	I/O/PWM	PWM (15.259 kHz to 125 MHz) or GPIO
FPWM8/GPIO12	24	I/O/PWM	PWM (15.259 kHz to 125 MHz) or GPIO
PWM1/GPI1	31	I/PWM	Fixed 10-kHz PWM output or GPI
PWM2/GPI2	32	I/PWM	Fixed 1-kHz PWM output or GPI
PWM3/GPI3	42	I/PWM	PWM (0.93 Hz to 7.8125 MHz) or GPI
PWM4/GPI4	41	I/PWM	PWM (0.93 Hz to 7.8125 MHz) or GPI
PMBus COMM INTERFACE			
PMBUS_CLK	15	I/O	PMBus clock (must have pullup to 3.3 V)
PMBUS_DATA	16	I/O	PMBus data (must have pullup to 3.3 V)
PMBUS_ALERT	27	O	PMBus alert, active-low, open-drain output (must have pullup to 3.3 V)
PMBUS_CNTRL	28	I	PMBus control
PMBUS_ADDR0	61	I	PMBus analog address input. Least-significant address bit
PMBUS_ADDR1	60	I	PMBus analog address input. Most-significant address bit
JTAG			
TRCK	10	O	Test return clock
TCK/GPIO19	36	I/O	Test clock or GPIO
TDO/GPIO20	37	I/O	Test data out or GPIO
TDI/GPIO21	38	I/O	Test data in (tie to V_{DD} with 10-k Ω resistor) or GPIO
TMS/GPIO22	39	I/O	Test mode select (tie to V_{DD} with 10-k Ω resistor) or GPIO
TRST	40	I	Test reset – tie to ground with 10-k Ω resistor

Table 1. PIN FUNCTIONS (continued)

PIN NAME	PIN NO.	I/O TYPE	DESCRIPTION
INPUT POWER AND GROUNDS			
RESET	9		Active-low device reset input. Hold low for at least 2 μ s to reset the device.
V33FB	58		3.3-V linear regulator feedback connection
V33A	46		Analog 3.3-V supply
V33D	45		Digital core 3.3-V supply
V33DIO1	7		Digital I/O 3.3-V supply
V33DIO2	44		Digital I/O 3.3-V supply
BPCAP	47		1.8-V bypass capacitor – tie 0.1- μ F capacitor to analog ground.
AVSS1	49		Analog ground
AVSS2	48		Analog ground
AVSS3	64		Analog ground
DVSS1	8		Digital ground
DVSS2	26		Digital ground
DVSS3	43		Digital ground
QFP ground pad	NA		Thermal pad – tie to ground plane.

FUNCTIONAL DESCRIPTION

TI FUSION GUI

The Texas Instruments *Fusion Digital Power Designer* is provided for device configuration. This PC-based graphical user interface (GUI) offers an intuitive I²C/PMBus interface to the device. It allows the design engineer to configure the system operating parameters for the application without directly using PMBus commands, store the configuration to on-chip nonvolatile memory, and observe system status (voltage, temperature, etc). *Fusion Digital Power Designer* is referenced throughout the data sheet as *Fusion GUI* and many sections include screenshots. The *Fusion GUI* can be downloaded from www.ti.com.

PMBUS INTERFACE

The PMBus is a serial interface specifically designed to support power management. It is based on the SMBus specification that is built on the I²C physical interface. The UCD90910 supports revision 1.1 of the PMBus standard. Wherever possible, standard PMBus commands are used to support the function of the device. For unique features of the UCD90910, MFR_SPECIFIC commands are defined to configure or activate those features. These commands are defined in the UCD90xxx Sequencer and System Health Controller PMBUS Command Reference (SLVU352).

This document makes frequent mention of the PMBus specification. Specifically, this document is *PMBus Power System Management Protocol Specification Part II – Command Language*, Revision 1.1, dated 5 February 2007. The specification is published by the Power Management Bus Implementers Forum and is available from www.pmbus.org.

The UCD90910 is PMBus compliant, in accordance with the *Compliance* section of the PMBus specification. The firmware is also compliant with the SMBus 1.1 specification, including support for the SMBus ALERT function. The hardware can support either 100-kHz or 400-kHz PMBus operation.

THEORY OF OPERATION

Modern electronic systems often use numerous microcontrollers, DSPs, FPGAs, and ASICs. Each device can have multiple supply voltages to power the core processor, analog-to-digital converter, or I/O. These devices are typically sensitive to the order and timing of how the voltages are sequenced on and off. The UCD90910 can sequence supply voltages to prevent malfunctions, intermittent operation, or device damage caused by improper power up or power down. Appropriate handling of under- and overvoltage faults, overcurrent faults and overtemperature faults can extend system life and improve long-term reliability. The UCD90910 stores power supply faults to on-chip nonvolatile flash memory for aid in system failure analysis.

Tach monitor inputs, PWM outputs, and temperature measurements can be combined, with a choice between two built-in fan-control algorithms to provide a stand-alone fan controller for independent operation of up to ten fans.

System reliability can be improved through four-corner testing during system verification. During four-corner testing, the system is operated at the minimum and maximum expected ambient temperature and with each power supply set to the minimum and maximum output voltage, commonly referred to as margining. The UCD90910 can be used to implement accurate closed-loop margining of up to 10 power supplies.

The UCD90910 ten-rail sequencer can be used in a PMBus- or pin-based control environment. The *Fusion GUI* provides a powerful but simple interface for configuring sequencing solutions for systems with between one and ten power supplies using 13 analog voltage-monitor inputs, four GPIs and 22 highly configurable GPIOs. A rail can include voltage, temperature, current, a power-supply enable and a margining output. At least one must be included in a rail definition. Once the user has defined how the power-supply rails should operate in a particular system, analog input pins and GPIOs can be selected to monitor and enable each supply ([Figure 3](#)).

Vout Config
Pin Assignment
Fault Responses and Limits
Fault Logging
System Watchdog
System Reset
Run Time Clock
Device Info
Other Config
All Config

Rails - Monitors & Enables
4 of 10 Assigned

Rail Name	Voltage	Temperature	Current	Enable	Margin PWM	Actions
Rail #1	Pin 1 MON1	Pin 54 MON12	Pin 56 MON13	Pin 11 GPIO1	<None>	Delete Configure
Rail #2	Pin 2 MON2	<None>	<None>	Pin 12 GPIO2	<None>	Delete Configure
Rail #3	Pin 3 MON3	<None>	<None>	Pin 13 GPIO3	<None>	Delete Configure
Rail #4	Pin 4 MON4	<None>	<None>	Pin 14 GPIO4	<None>	Delete Configure

[Add Rail](#)

GPIs - General Purpose Inputs
1 of 8 Assigned

GPI Name	Pin	Polarity	Special Behavior	Actions
GPI #1	Pin 17 FPWM1 GPIO5	Active High	---	Delete Configure

[Add GPI](#)

Logic Controlled GPIOs - General Purpose Outputs with Programmable State Logic
0 of 10 Assigned

You have not configured any logic controlled GPIOs; click the Add link below to add

[Add Logic Controlled GPIO](#)

Command Controlled GPIOs - General Purpose Outputs with Fixed State
0 of 22 Assigned

You have not configured any command controlled GPIOs; click the Add link below to add

[Add Command Controlled GPIO](#)

Fans
0 of 10 Assigned

You have not configured any fans; click the Add link below to add

[Add Fan](#)

PWMs - General Purpose Pulse-Width Modulation Outputs
0 of 12 Assigned

You have not configured any PWMs; click the Add link below to add

[Add PWM](#)

Figure 3. Fusion GUI Pin-Assignment Tab

After the pins have been configured, other key monitoring and sequencing criteria are selected for each rail from the Vout Config tab ([Figure 4](#)):

- Nominal operating voltage (Vout)
- Undervoltage (UV) and overvoltage (OV) warning and fault limits
- Margin-low and margin-high values
- Power-good on and power-good off limits
- PMBus or pin-based sequencing control (On/Off Config)
- Rails and GPIs for Sequence On dependencies

- Rails and GPIs for Sequence Off dependencies
- Turn-on and turn-off delay timing
- Maximum time allowed for a rail to reach POWER_GOOD_ON or POWER_GOOD_OFF after being enabled or disabled
- Other rails to turn off in case of a fault on a rail (fault-shutdown slaves)

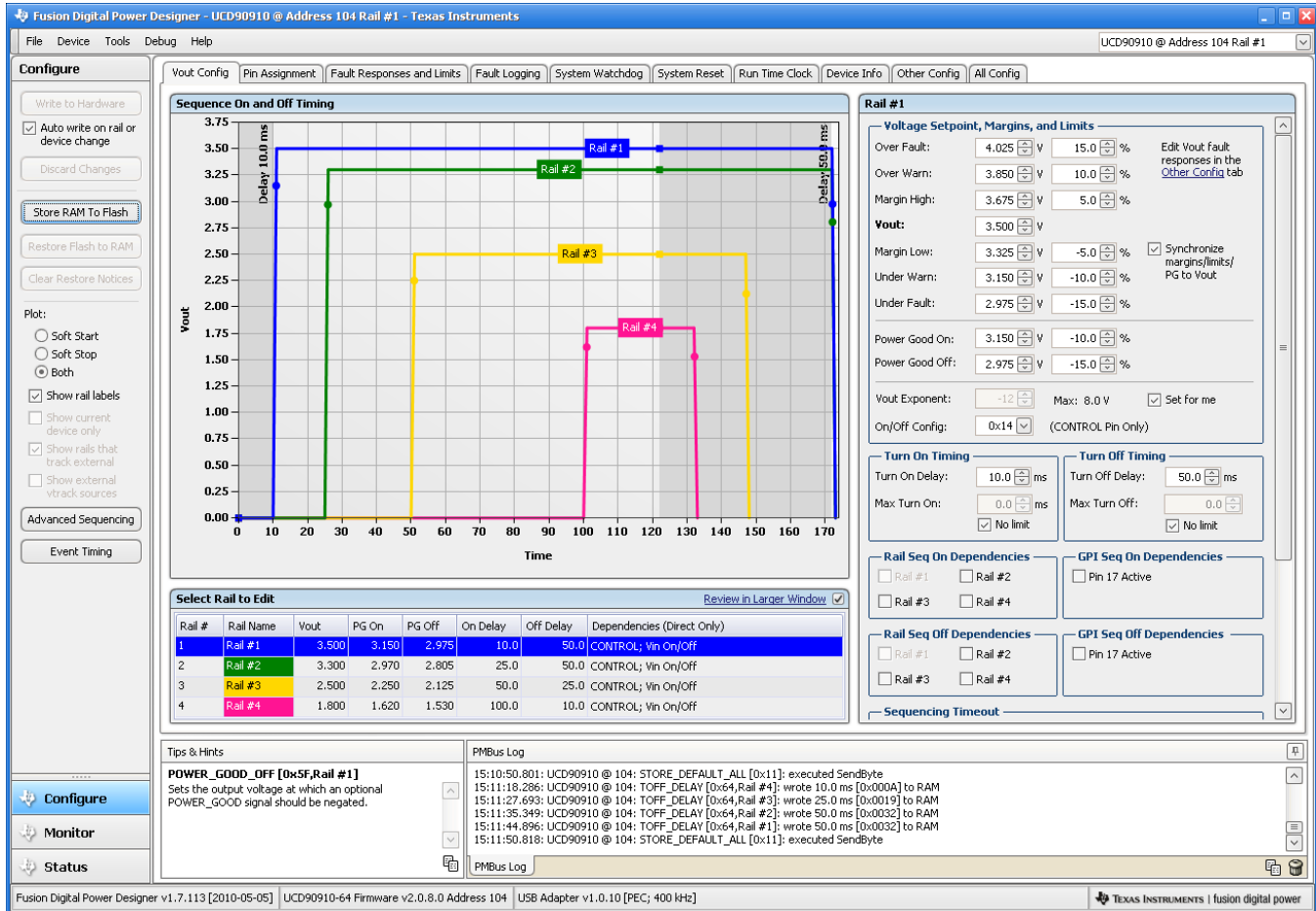

Figure 4. Fusion GUI Vout-Config Tab

The **Synchronize margins/limits/PG to Vout** checkbox is an easy way to change the nominal operating voltage of a rail and also update all of the other limits associated with that rail according to the percentages shown to the right of each entry.

The plot in the upper left section of **Figure 4** shows a simulation of the overall sequence-on and sequence-off configuration, including the nominal voltage, the turn-on and turn-off delay times, the power-good on and power-good off voltages and any timing dependencies between the rails.

After a rail voltage has reached its POWER_GOOD_ON voltage and is considered to be in regulation, it is compared against two UV and two OV thresholds in order to determine if a warning or fault limit has been exceeded. If a fault is detected, the UCD90910 responds based on a variety of flexible, user-configured options. Faults can cause rails to restart, shut down immediately, sequence off using turn-off delay times, or shut down a group of rails and sequence them back on. Different types of faults can result in different responses.

Fault responses, along with a number of other parameters including user-specific manufacturing information and external scaling and offset values, are selected in the different tabs within the Configure function of the *Fusion GUI*. Once the configuration satisfies the user requirements, it can be written to device SRAM if *Fusion GUI* is connected to a UCD90910 using an I²C/PMBus. SRAM contents can then be stored to data flash memory so that the configuration remains in the device after a reset or power cycle.

The *Fusion GUI* Monitor page has a number of options, including a device dashboard and a system dashboard, for viewing and controlling device and system status.

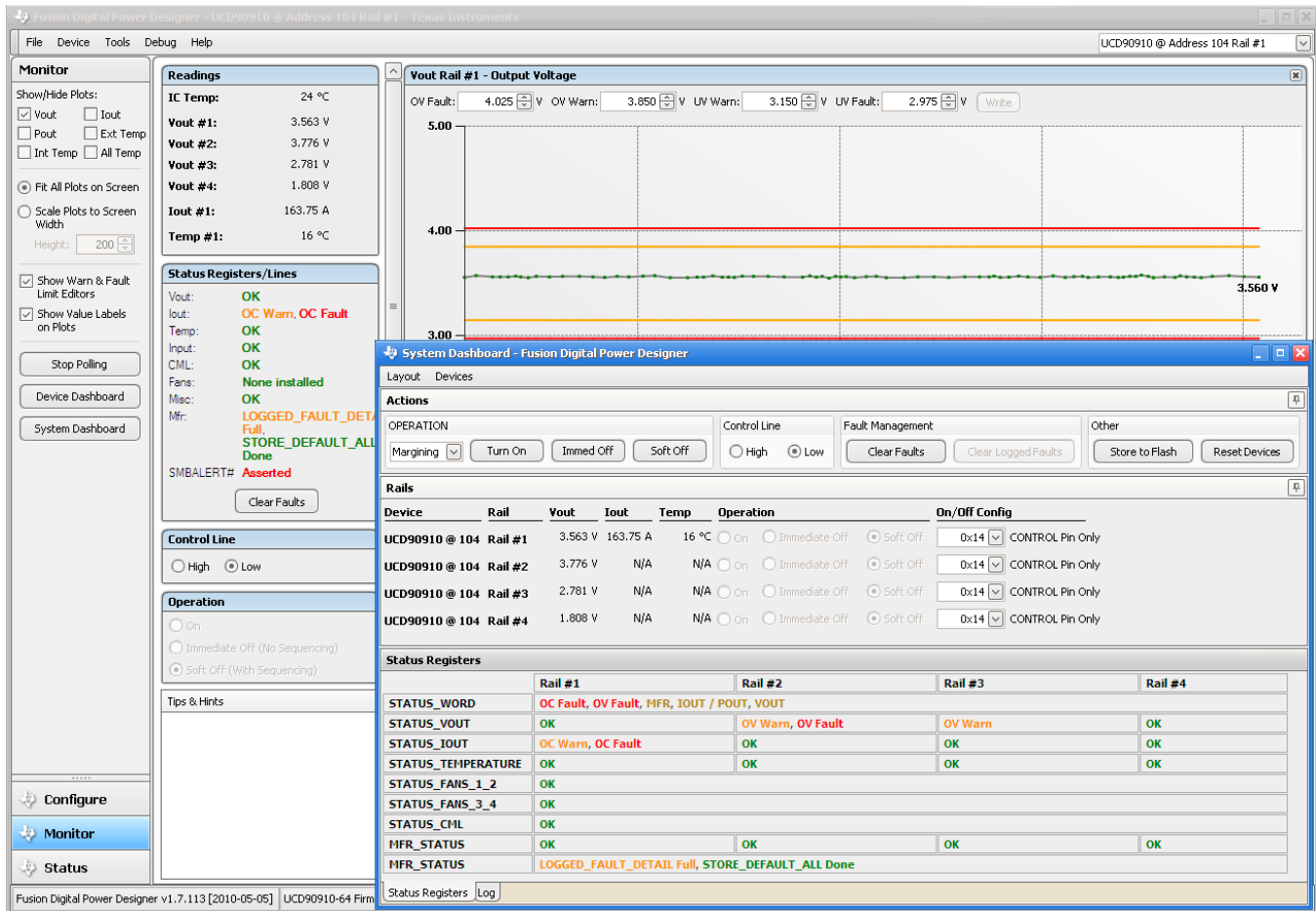

Figure 5. Fusion GUI Monitor Page With System Dashboard

The UCD90910 also has status registers for each rail and the capability to log faults to flash memory for use in system troubleshooting. This is helpful in the event of a power-supply or system failure. The status registers (Figure 6) and the fault log (Figure 7) are available in the *Fusion GUI*. See the *UCD90xxx Sequencer and System Health Controller PMBus Command Reference (SLVU352)* and the PMBus specification for detailed descriptions of each status register and supported PMBus commands.

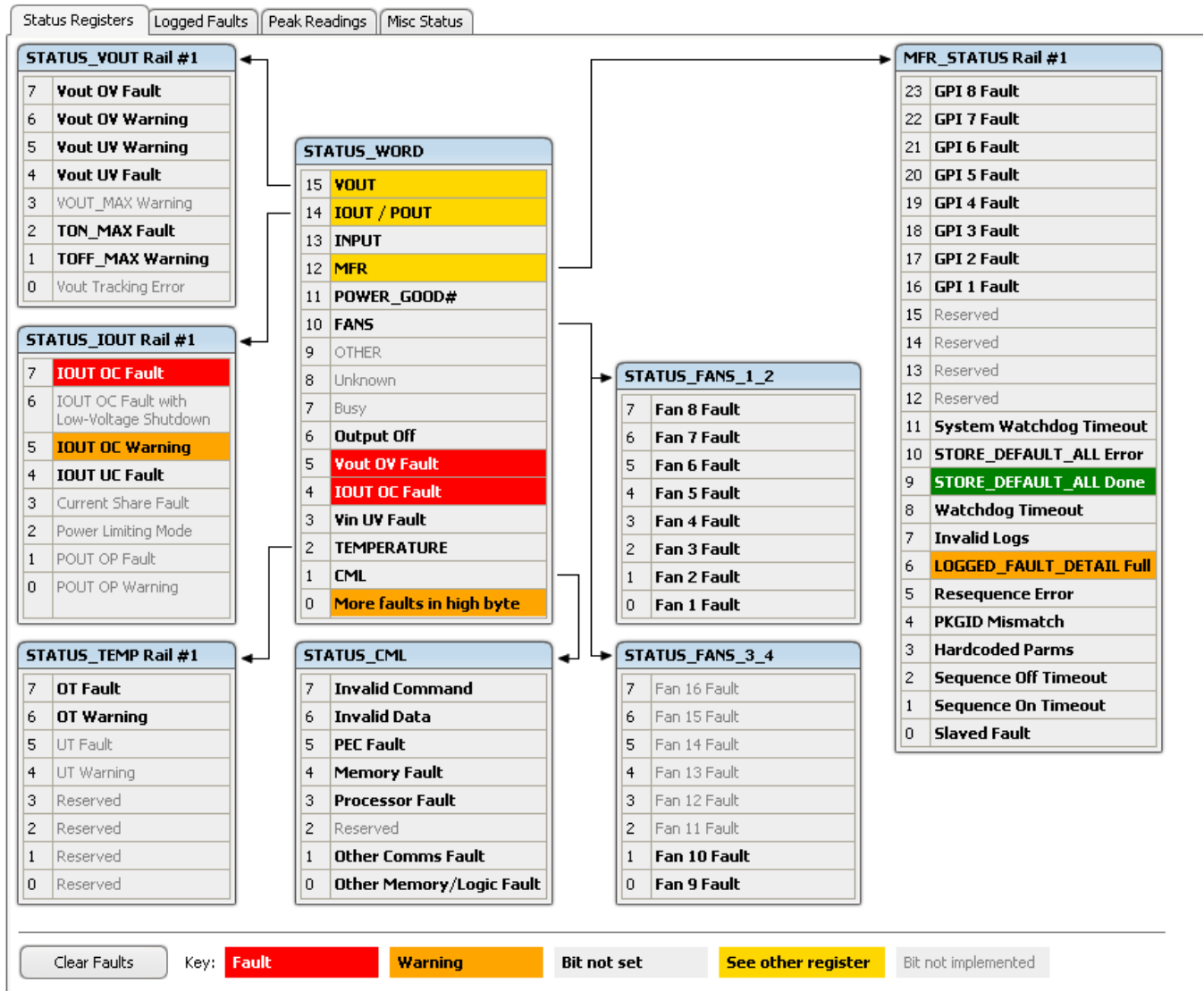

Figure 6. Fusion GUI Rail-Status

Status Registers	Logged Faults	Peak Readings	Misc Status																																																																								
<table border="1"> <thead> <tr> <th colspan="2">Common</th> <th colspan="2">GPIs</th> <th colspan="4">Fans</th> </tr> </thead> <tbody> <tr> <td>7</td><td>Reserved</td> <td>7</td><td>GPI 8 Fault</td> <td>15</td><td>Fan 16 Fault</td> <td>7</td><td>Fan 8 Fault</td> </tr> <tr> <td>6</td><td>Reserved</td> <td>6</td><td>GPI 7 Fault</td> <td>14</td><td>Fan 15 Fault</td> <td>6</td><td>Fan 7 Fault</td> </tr> <tr> <td>5</td><td>Reserved</td> <td>5</td><td>GPI 6 Fault</td> <td>13</td><td>Fan 14 Fault</td> <td>5</td><td>Fan 6 Fault</td> </tr> <tr> <td>4</td><td>Reserved</td> <td>4</td><td>GPI 5 Fault</td> <td>12</td><td>Fan 13 Fault</td> <td>4</td><td>Fan 5 Fault</td> </tr> <tr> <td>3</td><td>Watchdog Timeout</td> <td>3</td><td>GPI 4 Fault</td> <td>11</td><td>Fan 12 Fault</td> <td>3</td><td>Fan 4 Fault</td> </tr> <tr> <td>2</td><td>Re-Sequence Error</td> <td>2</td><td>GPI 3 Fault</td> <td>10</td><td>Fan 11 Fault</td> <td>2</td><td>Fan 3 Fault</td> </tr> <tr> <td>1</td><td>System Watchdog Timeout</td> <td>1</td><td>GPI 2 Fault</td> <td>9</td><td>Fan 10 Fault</td> <td>1</td><td>Fan 2 Fault</td> </tr> <tr> <td>0</td><td>Log Not Empty</td> <td>0</td><td>GPI 1 Fault</td> <td>8</td><td>Fan 9 Fault</td> <td>0</td><td>Fan 1 Fault</td> </tr> </tbody> </table>				Common		GPIs		Fans				7	Reserved	7	GPI 8 Fault	15	Fan 16 Fault	7	Fan 8 Fault	6	Reserved	6	GPI 7 Fault	14	Fan 15 Fault	6	Fan 7 Fault	5	Reserved	5	GPI 6 Fault	13	Fan 14 Fault	5	Fan 6 Fault	4	Reserved	4	GPI 5 Fault	12	Fan 13 Fault	4	Fan 5 Fault	3	Watchdog Timeout	3	GPI 4 Fault	11	Fan 12 Fault	3	Fan 4 Fault	2	Re-Sequence Error	2	GPI 3 Fault	10	Fan 11 Fault	2	Fan 3 Fault	1	System Watchdog Timeout	1	GPI 2 Fault	9	Fan 10 Fault	1	Fan 2 Fault	0	Log Not Empty	0	GPI 1 Fault	8	Fan 9 Fault	0	Fan 1 Fault
Common		GPIs		Fans																																																																							
7	Reserved	7	GPI 8 Fault	15	Fan 16 Fault	7	Fan 8 Fault																																																																				
6	Reserved	6	GPI 7 Fault	14	Fan 15 Fault	6	Fan 7 Fault																																																																				
5	Reserved	5	GPI 6 Fault	13	Fan 14 Fault	5	Fan 6 Fault																																																																				
4	Reserved	4	GPI 5 Fault	12	Fan 13 Fault	4	Fan 5 Fault																																																																				
3	Watchdog Timeout	3	GPI 4 Fault	11	Fan 12 Fault	3	Fan 4 Fault																																																																				
2	Re-Sequence Error	2	GPI 3 Fault	10	Fan 11 Fault	2	Fan 3 Fault																																																																				
1	System Watchdog Timeout	1	GPI 2 Fault	9	Fan 10 Fault	1	Fan 2 Fault																																																																				
0	Log Not Empty	0	GPI 1 Fault	8	Fan 9 Fault	0	Fan 1 Fault																																																																				
<table border="1"> <thead> <tr> <th colspan="2">Rail #1 Faults</th> <th colspan="2">Rail #2 Faults</th> <th colspan="2">Rail #3 Faults</th> <th colspan="2">Rail #4 Faults</th> </tr> </thead> <tbody> <tr> <td>7</td><td>SEQ_OFF_TIMEOUT</td> <td>7</td><td>SEQ_OFF_TIMEOUT</td> <td>7</td><td>SEQ_OFF_TIMEOUT</td> <td>7</td><td>SEQ_OFF_TIMEOUT</td> </tr> <tr> <td>6</td><td>SEQ_ON_TIMEOUT</td> <td>6</td><td>SEQ_ON_TIMEOUT</td> <td>6</td><td>SEQ_ON_TIMEOUT</td> <td>6</td><td>SEQ_ON_TIMEOUT</td> </tr> <tr> <td>5</td><td>OT Fault</td> <td>5</td><td>OT Fault</td> <td>5</td><td>OT Fault</td> <td>5</td><td>OT Fault</td> </tr> <tr> <td>4</td><td>IOUT UC Fault</td> <td>4</td><td>IOUT UC Fault</td> <td>4</td><td>IOUT UC Fault</td> <td>4</td><td>IOUT UC Fault</td> </tr> <tr> <td>3</td><td>IOUT OC Fault</td> <td>3</td><td>IOUT OC Fault</td> <td>3</td><td>IOUT OC Fault</td> <td>3</td><td>IOUT OC Fault</td> </tr> <tr> <td>2</td><td>TON_MAX Fault</td> <td>2</td><td>TON_MAX Fault</td> <td>2</td><td>TON_MAX Fault</td> <td>2</td><td>TON_MAX Fault</td> </tr> <tr> <td>1</td><td>Vout UV Fault</td> <td>1</td><td>Vout UV Fault</td> <td>1</td><td>Vout UV Fault</td> <td>1</td><td>Vout UV Fault</td> </tr> <tr> <td>0</td><td>Vout OV Fault</td> <td>0</td><td>Vout OV Fault</td> <td>0</td><td>Vout OV Fault</td> <td>0</td><td>Vout OV Fault</td> </tr> </tbody> </table>				Rail #1 Faults		Rail #2 Faults		Rail #3 Faults		Rail #4 Faults		7	SEQ_OFF_TIMEOUT	7	SEQ_OFF_TIMEOUT	7	SEQ_OFF_TIMEOUT	7	SEQ_OFF_TIMEOUT	6	SEQ_ON_TIMEOUT	6	SEQ_ON_TIMEOUT	6	SEQ_ON_TIMEOUT	6	SEQ_ON_TIMEOUT	5	OT Fault	5	OT Fault	5	OT Fault	5	OT Fault	4	IOUT UC Fault	4	IOUT UC Fault	4	IOUT UC Fault	4	IOUT UC Fault	3	IOUT OC Fault	3	IOUT OC Fault	3	IOUT OC Fault	3	IOUT OC Fault	2	TON_MAX Fault	2	TON_MAX Fault	2	TON_MAX Fault	2	TON_MAX Fault	1	Vout UV Fault	1	Vout UV Fault	1	Vout UV Fault	1	Vout UV Fault	0	Vout OV Fault	0	Vout OV Fault	0	Vout OV Fault	0	Vout OV Fault
Rail #1 Faults		Rail #2 Faults		Rail #3 Faults		Rail #4 Faults																																																																					
7	SEQ_OFF_TIMEOUT	7	SEQ_OFF_TIMEOUT	7	SEQ_OFF_TIMEOUT	7	SEQ_OFF_TIMEOUT																																																																				
6	SEQ_ON_TIMEOUT	6	SEQ_ON_TIMEOUT	6	SEQ_ON_TIMEOUT	6	SEQ_ON_TIMEOUT																																																																				
5	OT Fault	5	OT Fault	5	OT Fault	5	OT Fault																																																																				
4	IOUT UC Fault	4	IOUT UC Fault	4	IOUT UC Fault	4	IOUT UC Fault																																																																				
3	IOUT OC Fault	3	IOUT OC Fault	3	IOUT OC Fault	3	IOUT OC Fault																																																																				
2	TON_MAX Fault	2	TON_MAX Fault	2	TON_MAX Fault	2	TON_MAX Fault																																																																				
1	Vout UV Fault	1	Vout UV Fault	1	Vout UV Fault	1	Vout UV Fault																																																																				
0	Vout OV Fault	0	Vout OV Fault	0	Vout OV Fault	0	Vout OV Fault																																																																				

Figure 7. Fusion GUI Flash-Error Log (Logged Faults)

POWER-SUPPLY SEQUENCING

The UCD90910 can control the turn-on and turn-off sequencing of up to ten voltage rails by using a GPIO to set a power-supply enable pin high or low. In PMBus-based designs, the system PMBus master can initiate a sequence-on event by asserting the PMBUS_CNTRL pin or by sending the OPERATION command over the I²C serial bus. In pin-based designs, the PMBUS_CNTRL pin can also be used to sequence-on and sequence-off.

The auto-enable setting ignores the OPERATION command and the PMBUS_CNTRL pin. Sequence-on is started at power up after any dependencies and time delays are met for each rail. A rail is considered to be on or within regulation when the measured voltage for that rail crosses the power-good on (POWER_GOOD_ON⁽¹⁾) limit. The rail is still in regulation until the voltage drops below power-good off (POWER_GOOD_OFF). In the case that there isn't voltage monitoring set for a given rail, that rail is considered ON if it is commanded on (either by OPERATION command, PMBUS_CNTRL pin, or auto-enable) and (TON_DELAY + TON_MAX_FAULT_LIMIT) time passes. Also, a rail is considered OFF if that rail is commanded OFF and (TOFF_DELAY + TOFF_MAX_WARN_LIMIT) time passes

(1) In this document, configuration parameters such as Power Good On are referred to using Fusion GUI names. The UCD90xxx Sequencer and System Health Controller PMBus Command Reference name is shown in parentheses (POWER_GOOD_ON) the first time the parameter appears.

Turn-on Sequencing

The following sequence-on options are supported for each rail:

- Monitor only – do not sequence-on
- Fixed delay time after an OPERATION command to turn on
- Fixed delay time after assertion of the PMBUS_CNTRL pin
- Fixed time after one or a group of parent rails achieves regulation (POWER_GOOD_ON)
- Fixed time after a designated GPI has reached a user-specified state
- Any combination of the previous options

The maximum TON_DELAY time is 3276 ms.

Turn-off Sequencing

The following sequence-off options are supported for each rail:

- Monitor only – do not sequence-off
- Fixed delay time after an OPERATION command to turn off
- Fixed delay time after deassertion of the PMBUS_CNTRL pin
- Fixed time after one or a group of parent rails drop below regulation (POWER_GOOD_OFF)
- Fixed delay time in response to an undervoltage, overvoltage, undercurrent, overcurrent, undertemperature, overtemperature, or max turn-on fault on the rail
- Fixed delay time in response to a fault on a different rail when set as a fault shutdown slave to the faulted rail
- Fixed delay time in response to a GPI reaching a user-specified state
- Any combination of the previous options

The maximum TOFF_DELAY time is 3276 ms.

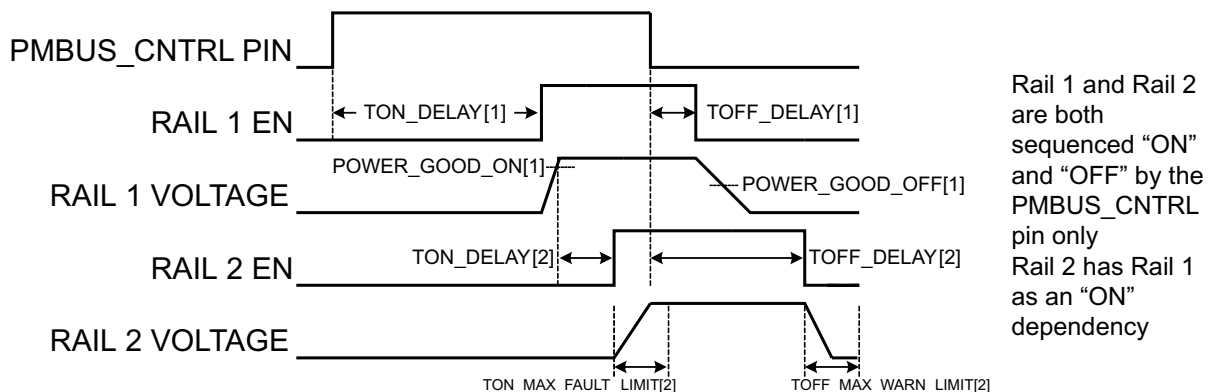

Figure 8. Sequence-on and Sequence-off Timing

Sequencing Configuration Options

In addition to the turn-on and turn-off sequencing options, the time between when a rail is enabled and when the monitored rail voltage must reach its power-good-on setting can be configured using max turn-on (TON_MAX_FAULT_LIMIT). Max turn-on can be set in 1-ms increments. A value of 0 ms means that there is no limit and the device can try to turn on the output voltage indefinitely.

Rails can be configured to turn off immediately or to sequence-off according to user-defined delay times. A sequenced shutdown is configured by selecting the appropriate turn-off delay (TOFF_DELAY) times for each rail. The turn-off delay times begin when the PMBUS_CNTRL pin is deasserted, when the PMBus OPERATION command is used to give a soft-stop command, or when a fault occurs on a rail that has other rails set as fault-shutdown slaves.

Shutdowns on one rail can initiate shutdowns of other rails or controllers. In systems with multiple UCD90910s, it is possible for each controller to be both a master and a slave to another controller.

MONITORING

The UCD90910 has 13 monitor input pins (MONx) that are multiplexed into a 2.5V referenced 12-bit ADC. The monitor pins can be configured so that they can measure voltage signals to report voltage, current and temperature type measurements. A single rail can include all three measurement types, each monitored on separate MON pins. If a rail has both voltage and current assigned to it, then the user can calculate power for the rail. Digital filtering applied to each MON input depends on the type of signal. Voltage inputs have no filtering. Current and temperature inputs have a low-pass filter.

Although the monitor results can be reported with a resolution of about 15 μV , the real conversion resolution of 610 μV is fixed by the 2.5-V reference and the 12-bit ADC.

Table 2. Voltage Range and Resolution

VOLTAGE RANGE (Volts)	RESOLUTION (millivolts)
0 to 127.99609	3.90625
0 to 63.99805	1.956313
0 to 31.99902	0.97656
0 to 15.99951	0.48824
0 to 7.99976	0.24414
0 to 3.99988	0.12207
0 to 1.99994	0.06104
0 to 0.99997	0.03052

VOLTAGE MONITORING

Up to 10 rail voltages can be monitored using the analog input pins. The input voltage range is 0 V–2.5 V for MON pins 1–6, 59, 62 and 63. Pins 50, 52, 54, and 56 can measure down to 0.2 V. Any voltage between 0 V and 0.2 V on these pins is read as 0.2 V. External resistors can be used to attenuate voltages higher than 2.5 V.

The ADC operates continuously, requiring 3.89 μs to convert a single analog input and 54.5 μs to convert all 14 of the analog inputs, including the onboard temperature sensor. Each rail is sampled by the sequencing and monitoring algorithm every 400 μs . The maximum source impedance of any sampled voltage should be less than 4 k Ω . The source impedance limit is particularly important when a resistor-divider network is used to lower the voltage applied to the analog input pins.

MON1 - MON6 can be configured using digital hardware comparators, which can be used to achieve faster fault responses. Each hardware comparator has four thresholds (two UV (Fault and Warning) and two OV (Fault and Warning)). The hardware comparators respond to UV or OV conditions in about 80 μs (faster than 400 μs for the ADC inputs) and can be used to disable rails or assert GPOs. The only fault response available for the hardware comparators is to shut down immediately.

An internal 2.5-V reference is used by the ADC. The ADC reference has a tolerance of $\pm 0.5\%$ between 0°C and 125°C and a tolerance of $\pm 1\%$ between –40°C and 125°C. An external voltage divider is required for monitoring voltages higher than 2.5 V. The nominal rail voltage and the external scale factor can be entered into the *Fusion GUI* and are used to report the actual voltage being monitored instead of the ADC input voltage. The nominal voltage is used to set the range and precision of the reported voltage according to [Table 2](#).

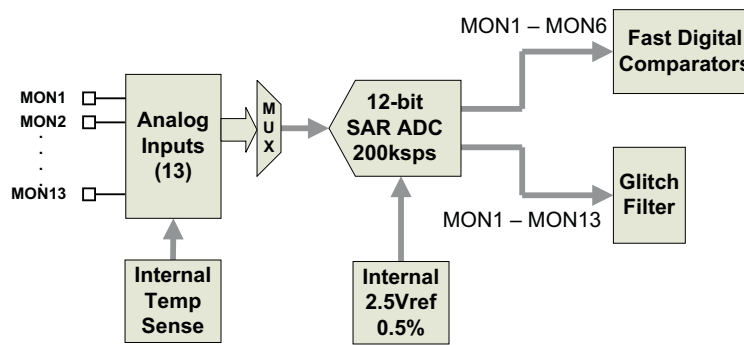

Figure 9. Monitoring Block Diagram

CURRENT MONITORING

Current can be monitored using the analog inputs. External circuitry, see [Figure 10](#), must be used in order to convert the current to a voltage within the range of the UCD90910 MONx input being used.

If a monitor input is configured as a current, the measurements are smoothed by a sliding-average digital filter. The current for 1 rail is measured every 200 μ s. If the device is programmed to support 10 rails (independent of current not being monitored at all rails), then each rail's current will get measured every 2ms. The current calculation is done with a sliding average using the last 4 measurements. The filter reduces the probability of false fault detections, and introduces a small delay to the current reading. If a rail is defined with a voltage monitor and a current monitor, then monitoring for undercurrent warnings begins once the rail voltage reaches POWER_GOOD_ON. If the rail does not have a voltage monitor, then current monitoring begins after TON_DELAY.

The device supports multiple PMBus commands related to current, including READ_IOUT, which reads external currents from the MON pins; IOUT_OC_FAULT_LIMIT, which sets the overcurrent fault limit; IOUT_OC_WARN_LIMIT, which sets the overcurrent warning limit; and IOUT_UC_FAULT_LIMIT, which sets the undercurrent fault limit. The *UCD90xxx Sequencer and System Health Controller PMBus Command Reference* contains a detailed description of how current fault responses are implemented using PMBus commands.

IOUT_CAL_GAIN is a PMBus command that allows the scale factor of an external current sensor and any amplifiers or attenuators between the current sensor and the MON pin to be entered by the user in milliohms. IOUT_CAL_OFFSET is the current that results in 0 V at the MON pin. The combination of these PMBus commands allows current to be reported in amperes. The example below using the INA196 would require programming IOUT_CAL_GAIN to $R_{sense}(m\Omega) \times 20$.

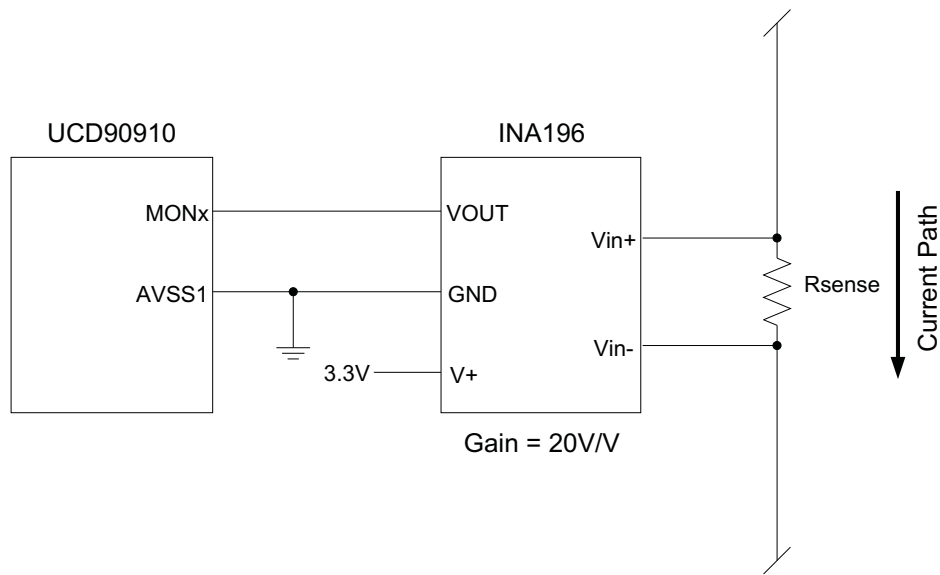

Figure 10. Current Monitoring Circuit Example Using the INA196

REMOTE TEMPERATURE MONITORING AND INTERNAL TEMPERATURE SENSOR

The UCD90910 has support for internal and remote temperature sensing. The internal temperature sensor requires no calibration and can report the device temperature via the PMBus interface. The remote temperature sensor can report the remote temperature by using a configurable gain and offset for the type of sensor that is used in the application such as a linear temperature sensor (LTS) connected to the analog inputs.

External circuitry must be used in order to convert the temperature to a voltage within the range of the UCD90910 MONx input being used.

If an input is configured as a temperature, the measurements are smoothed by a sliding average digital filter. The temperature for 1 rail is measured every 100ms. If the device is programmed to support 10 rails (independent of temperature not being monitored at all rails), then each rail's temperature will get measured every 1s. The temperature calculation is done with a sliding average using the last 16 measurements. The filter reduces the probability of false fault detections, and introduces a small delay to the temperature reading. The internal device temperature is measured using a silicon diode sensor with an accuracy of $\pm 5^{\circ}\text{C}$ and is also monitored using the ADC. Temperature monitoring begins immediately after reset and initialization.

The device supports multiple PMBus commands related to temperature, including `READ_TEMPERATURE_1`, which reads the internal temperature; `READ_TEMPERATURE_2`, which reads external temperatures; and `OT_FAULT_LIMIT` and `OT_WARN_LIMIT`, which set the overtemperature fault and warning limit. The *UCD90xxx Sequencer and System Health Controller PMBus Command Reference* contains a detailed description of how temperature-fault responses are implemented using PMBus commands.

`TEMPERATURE_CAL_GAIN` is a PMBus command that allows the scale factor of an external temperature sensor and any amplifiers or attenuators between the temperature sensor and the MON pin to be entered by the user in $^{\circ}\text{C}/\text{V}$. `TEMPERATURE_CAL_OFFSET` is the temperature that results in 0 V at the MON pin. The combination of these PMBus commands allows temperature to be reported in degrees Celsius.

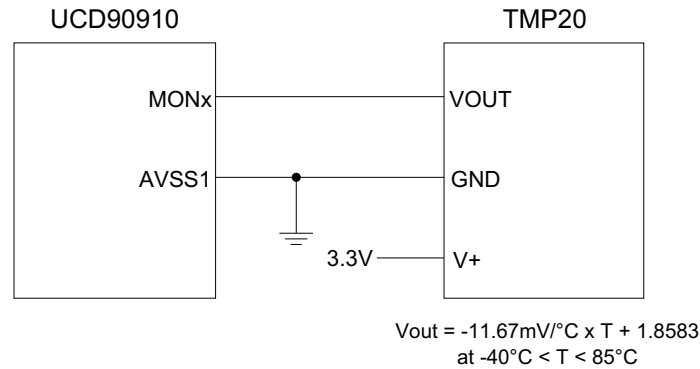

Figure 11. Remote Temperature Monitoring Circuit Example Using the TMP20

TEMPERATURE BY HOST INPUT

If the host system has the option of not using the temperature-sensing capability of the UCD90910, it can still provide the desired temperature to the UCD90910 through PMBus. The host may have temperature measurements available through I²C or SPI interfaced temperature sensors. The UCD90910 would use the temperature given by the host in place of an external temperature measurement for a given rail. The temperature provided by the host would still be used for detecting overtemperature warnings or faults, logging peak temperatures, input to Boolean logic-builder functions, and feedback for the fan-control algorithms. To write a temperature associated with a rail, the PMBus command used is the READ_TEMPERATURE_2 command. If the host writes that command, the value written will be used as the temperature until another value is written. This is true whether a monitor pin was assigned to the temperature or not. When there is a monitor pin associated with the temperature, once READ_TEMPERATURE_2 is written, the monitor pin is not used again until the part is reset. When there is not a monitor pin associated with the temperature, the internal temperature sensor is used for the temperature until the READ_TEMPERATURE_2 command is written.

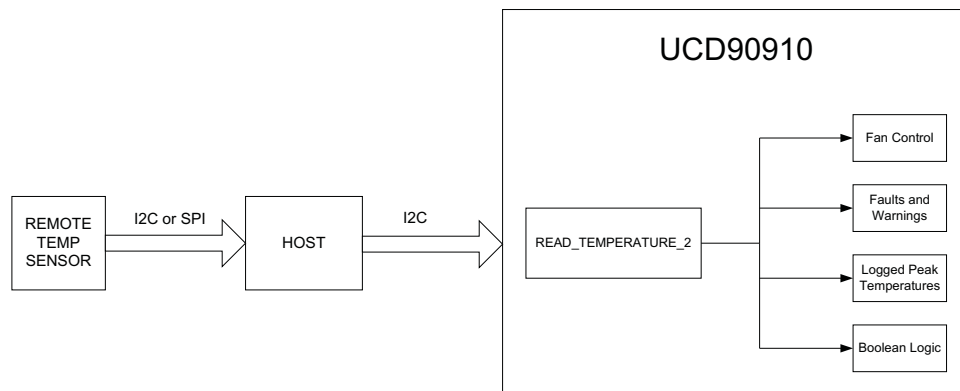

Figure 12. Temperature Provided by Host

FAULT RESPONSES AND ALERT PROCESSING

Device monitors that the rail stays within a window of normal operation. There are two programmable warning levels (under and over) and two programmable fault levels (under and over). When any monitored voltage, current, or temperature goes outside of the warning or fault window, the PMBALERT# pin is asserted immediately, and the appropriate bits are set in the PMBus status registers (see Figure 6). Detailed descriptions of the status registers are provided in the *UCD90xxx Sequencer and System Health Controller PMBus Command Reference* and the *PMBus Specification*.

A programmable glitch filter can be enabled or disabled for each MON input. A glitch filter for an input defined as a voltage can be set between 0 and 102 ms with 400- μ s resolution. A glitch filter for an input defined as a current or temperature can be between 0 and 25.5 seconds with 100-ms resolution. The longer time constants are due to the fixed low-pass digital filters associated with current and temperature inputs.

Fault-response decisions are based on results from the 12-bit ADC. The device cycles through the ADC results and compares them against the programmed limits. The time to respond to an individual event is determined by when the event occurs within the ADC conversion cycle and the selected fault response.

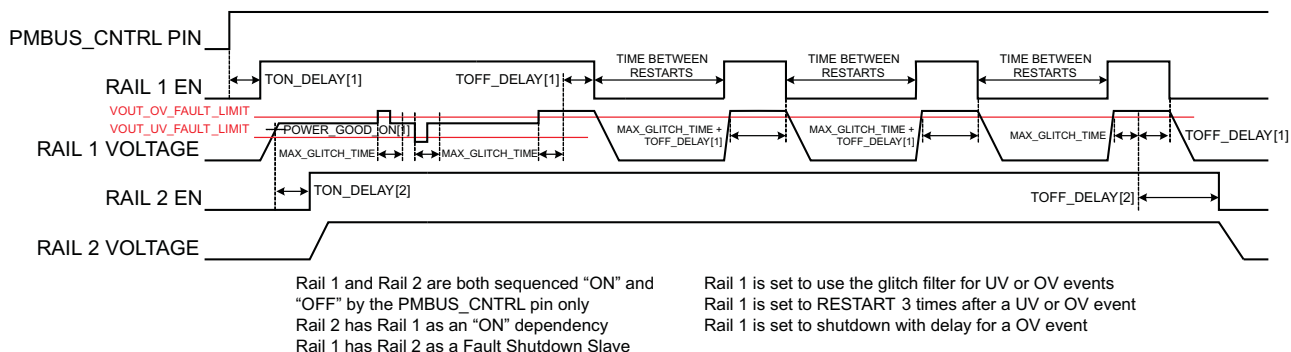

Figure 13. Sequencing and Fault-Response Timing

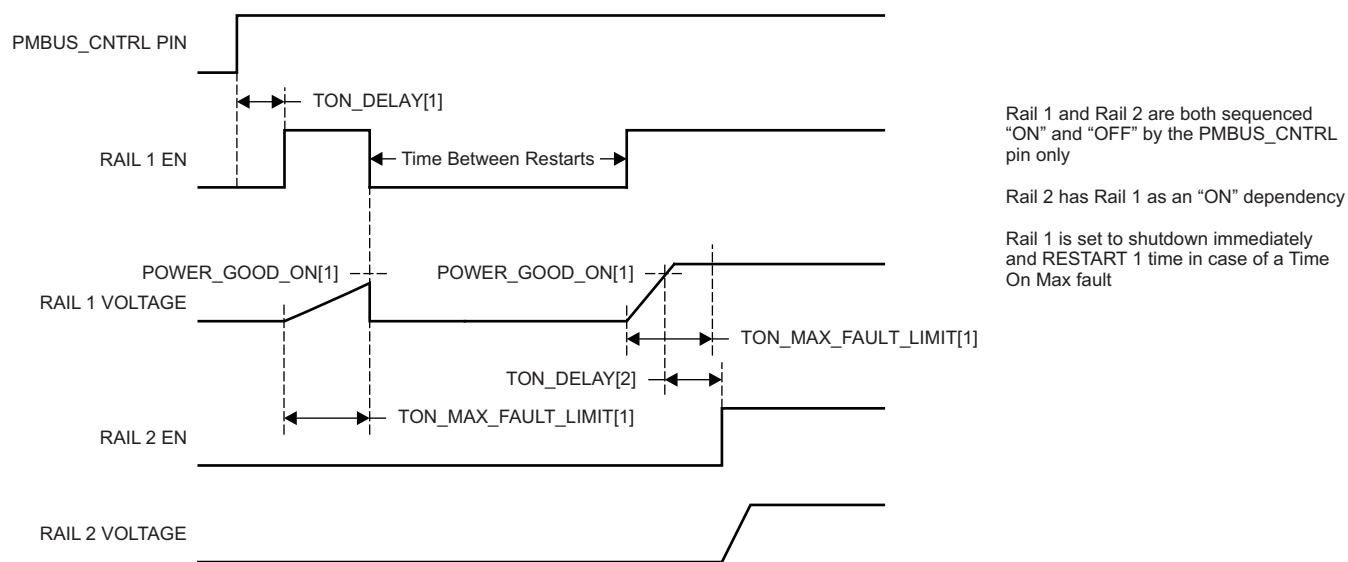

Figure 14. Maximum Turn-on Fault

The configurable fault limits are:

TON_MAX_FAULT – Flagged if a rail that is enabled does not reach the POWER_GOOD_ON limit within the configured time

VOUT_UV_WARN – Flagged if a voltage rail drops below the specified UV warning limit after reaching the POWER_GOOD_ON setting

VOUT_UV_FAULT – Flagged if a rail drops below the specified UV fault limit after reaching the POWER_GOOD_ON setting

VOUT_OV_WARN – Flagged if a rail exceeds the specified OV warning limit at any time during startup or operation

VOUT_OV_FAULT – Flagged if a rail exceeds the specified OV fault limit at any time during startup or operation

MAX_TOFF_WARN – Flagged if a rail that is commanded to shut down does not reach 12.5% of the nominal rail voltage within the configured time

Faults are more serious than warnings. The PMBALERT# pin is always asserted immediately if a warning or fault occurs. If a warning occurs, the following takes place:

Warning Actions

- Immediately assert the PMBALERT# pin
- Status bit is flagged
- Assert a GPIO pin (optional)
- Warnings are not logged to flash

A number of fault response options can be chosen from:

Fault Responses

- *Continue Without Interruption*: Flag the fault and take no action
- *Shut Down Immediately*: Shut down the faulted rail immediately and restart according to the rail configuration
- *Shut Down using TOFF_DELAY*: If a fault occurs on a rail, exhaust whatever retries are configured. If the rail does not come back, schedule the shutdown of this rail and all fault-shutdown slaves. All selected rails, including the faulty rail, are sequenced off according to their T_OFF_DELAY times. If Do Not Restart is selected, then sequence off all selected rails when the fault is detected.

Restart

- *Do Not Restart*: Do not attempt to restart a faulted rail after it has been shut down.
- *Restart Up To N Times*: Attempt to restart a faulted rail up to 14 times after it has been shut down. The time between restarts is measured between when the rail enable pin is deasserted (after any glitch filtering and turn-off delay times, if configured to observe them) and then reasserted. It can be set between 0 and 1275 ms in 5-ms increments.
- *Restart Continuously*: Same as *Restart Up To N Times* except that the device continues to restart until the fault goes away, it is commanded off by the specified combination of PMBus OPERATION command and PMBUS_CNTRL pin status, the device is reset, or power is removed from the device.
- *Shut Down Rails and Sequence On (Re-sequence)*: Shut down selected rails immediately or after continue-operation time is reached and then sequence-on those rails using turn-on delay times

SHUT DOWN ALL RAILS AND SEQUENCE ON (RESEQUENCE)

In response to a fault, or a RESEQUENCE command, the UCD90910 can be configured to turn off a set of rails and then sequence them back on. To sequence all rails in the system, then all rails must be selected as fault-shutdown slaves of the faulted rail. The rails designated as fault-shutdown slaves will do soft shutdowns regardless of whether the faulted rail is set to stop immediately or stop with delay. Shut-down-all-rails and sequence-on are not performed until retries are exhausted for a given fault.

While waiting for the rails to turn off, an error is reported if any of the rails reaches its TOFF_MAX_WARN_LIMIT. There is a configurable option to continue with the resequencing operation if this occurs. After the faulted rail and fault-shutdown slaves sequence-off, the UCD90910 waits for a programmable delay time between 0 and 1275 ms in increments of 5 ms and then sequences-on the faulted rail and fault-shutdown slaves according to the start-up sequence configuration. This is repeated until the faulted rail and fault-shutdown slaves successfully achieve regulation or for a user-selected 1, 2, 3, or 4 times. If the resequence operation is successful, the resequence counter is reset if all of the rails that were resequenced maintain normal operation for one second. If the rails are resequenced the maximum number times and they fail to reach normal operation, a device reset is required to reset the resequence counter.

Once shut-down-all-rails and sequence-on begin, any faults on the fault-shutdown slave rails are ignored. If there are two or more simultaneous faults with different fault-shutdown slaves, the more conservative action is taken. For example, if a set of rails is already on its second resequence and the device is configured to resequence three times, and another set of rails enters the resequence state, that second set of rails is only resequenced once. Another example – if one set of rails is waiting for all of its rails to shut down so that it can resequence, and another set of rails enters the resequence state, the device now waits for all rails from both sets to shut down before resequencing.

GPIOs

The UCD90910 has 22 GPIO pins that can function as either inputs or outputs. Each GPIO has configurable output mode options including open-drain or push-pull outputs that can be actively driven to 3.3 V or ground. There are an additional four pins that can be used as either inputs or PWM outputs but not as GPOs. [Table 3](#) lists possible uses for the GPIO pins and the maximum number of each type for each use. GPIO pins can be dependents in sequencing and alarm processing. They can also be used for system-level functions such as external interrupts, power-goods, resets, or for the cascading of multiple devices. GPOs can be sequenced up or down by configuring a rail without a MON pin but with a GPIO set as an enable.

Table 3. GPIO Pin Configuration Options

PIN NAME	PIN	RAIL EN (10 MAX)	GPI (8 MAX)	GPO (10 MAX)	FAN TACH (10 MAX)	FAN PWM (10 MAX)	PWM OUT (12 MAX)	MARGIN PWM (10 MAX)
FPWM1/GPIO5	17	X	X	X	X	X	X	X
FPWM2/GPIO6	18	X	X	X	X	X	X	X
FPWM3/GPIO7	19	X	X	X	X	X	X	X
FPWM4/GPIO8	20	X	X	X	X	X	X	X
FPWM5/GPIO9	21	X	X	X	X	X	X	X
FPWM6/GPIO10	22	X	X	X	X	X	X	X
FPWM7/GPIO11	23	X	X	X	X	X	X	X
FPWM8/GPIO12	24	X	X	X	X	X	X	X
FANTAC1/GPI1/PWM1	31		X		X		X	
FANTAC2/GPI2/PWM2	32		X		X		X	
FANTAC3/GPI3/PWM3	42		X		X	X	X	X
FANTAC4/GPI4/PWM4	41		X		X	X	X	X
GPIO1	11	X	X	X	X			
GPIO2	12	X	X	X	X			
GPIO3	13	X	X	X	X			
GPIO4	14	X	X	X	X			
GPIO13	25	X	X	X	X			
GPIO14	29	X	X	X	X			
GPIO15	30	X	X	X	X			
GPIO16	33	X	X	X	X			
GPIO17	34	X	X	X	X			
GPIO18	35	X	X	X	X			
TCK/GPIO19	36	X	X	X	X			
TDO/GPIO20	37	X	X	X	X			
TDI/GPIO21	38	X	X	X	X			
TMS/GPIO22	39	X	X	X	X			

GPIO Control

The GPIOs when configured as outputs can be controlled by PMBus commands or through logic defined in internal Boolean function blocks. Controlling GPOs by PMBus commands (GPIO_SELECT and GPIO_CONFIG) can be used to have control over LEDs, enable switches, etc. with the use of an I2C interface. See the UCD90xxx Sequencer and System Health Controller PMBus Command Reference for details on controlling a GPO using PMBus commands.

GPIO Dependencies

GPIOs can be configured as outputs that are based on Boolean combinations of up to four ANDs all ORed together (Figure 15). Inputs to the logic blocks can include GPIs and rail-status flags. One rail status type is selectable as an input for each AND gate in a Boolean block. For a selected rail status, the status flags of all active rails can be included as inputs to the AND gate. *_LATCH* rail-status types stay asserted until cleared by a MFR PMBus command or by a specially configured GPI pin. The different rail-status types are shown in Table 4. See the *UCD90xxx Sequencer and System Health Controller PMBus Command Reference* for complete definitions of rail-status types.

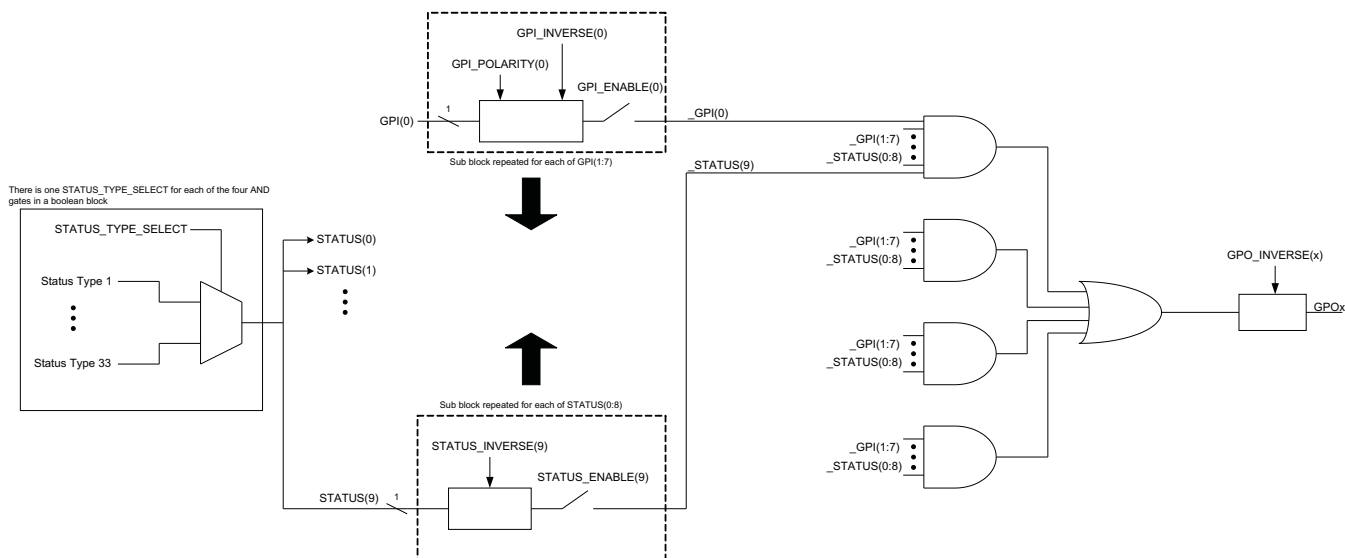

Figure 15. Boolean Logic Combinations

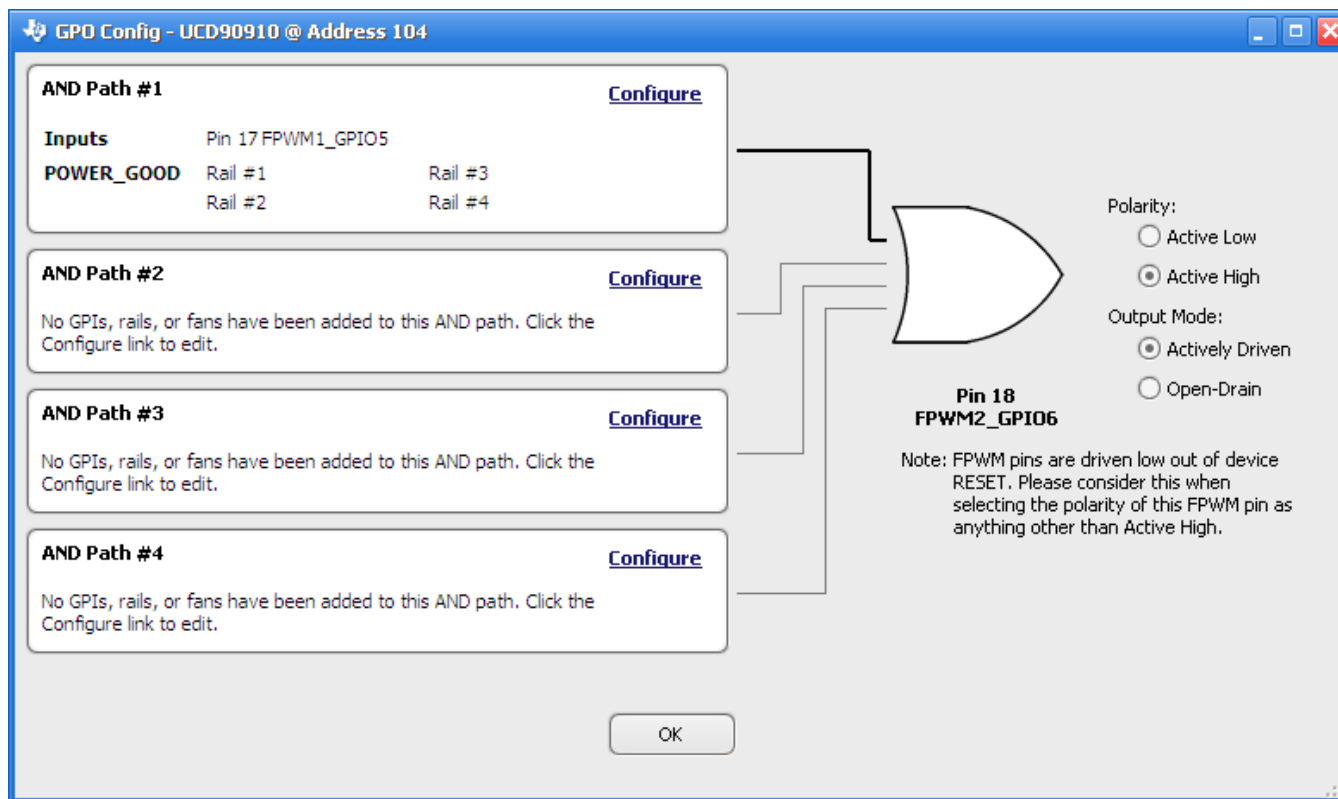

Figure 16. Fusion GUI Boolean Logic Builder

Table 4. Rail-Status Types for Boolean Logic

Rail-Status Types		
POWER_GOOD	IOUT_UC_FAULT	TON_MAX_FAULT_LATCH
MARGIN_EN	TEMP_OT_FAULT	TOFF_MAX_WARN_LATCH

Table 4. Rail-Status Types for Boolean Logic (continued)

Rail-Status Types		
MRG_LOW_nHIGH	TEMP_OT_WARN	IOUT_OC_FAULT_LATCH
VOUT_OV_FAULT	SEQ_ON_TIMEOUT	IOUT_OC_WARN_LATCH
VOUT_OV_WARN	SEQ_OFF_TIMEOUT	IOUT_UC_FAULT_LATCH
VOUT_UV_WARN	FAN_FAULT	TEMP_OT_FAULT_LATCH
VOUT_UV_FAULT	SYSTEM_WATCHDOG_TIMEOUT	TEMP_OT_WARN_LATCH
TON_MAX_FAULT	VOUT_OV_FAULT_LATCH	SEQ_ON_TIMEOUT_LATCH
TOFF_MAX_WARN	VOUT_OV_WARN_LATCH	SEQ_OFF_TIMEOUT_LATCH
IOUT_OC_FAULT	VOUT_UV_WARN_LATCH	FAN_FAULT_LATCH
IOUT_OC_WARN	VOUT_UV_FAULT_LATCH	SYSTEM_WATCHDOG_TIMEOUT_LATCH

GPI Special Functions

Figure 17 lists and describes five special input functions for which GPIs can be used. There can be no more than one pin assigned to each of these functions.

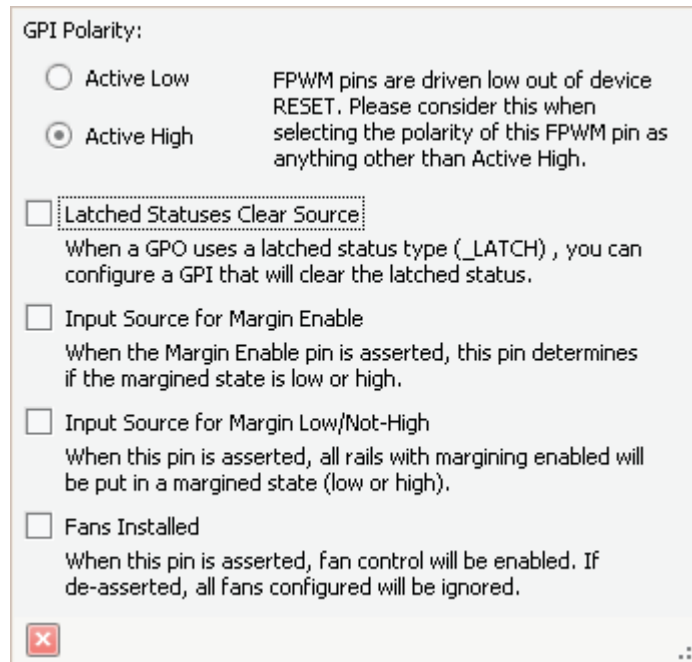

Figure 17. GPI Configuration – Special Input Functions

Power-Supply Enables

Each GPIO can be configured as a rail-enable pin with either active-low or active-high polarity. Output mode options include open-drain or push-pull outputs that can be actively driven to 3.3 V or ground. During reset, the GPIO pins are high-impedance except for FPWM/GPIO pins 17–24, which are driven low. External pulldown or pullup resistors can be tied to the enable pins to hold the power supplies off during reset. The UCD90910 can support a maximum of 10 enable pins.

NOTE

GPIO pins that have FPWM capability (pins 17-24) should only be used as power-supply enable signals if the signal is active high.

Cascading Multiple Devices

A GPIO pin can be used to coordinate multiple controllers by using it as a power good-output from one device and connecting it to the PMBUS_CNTRL input pin of another. This imposes a master/slave relationship among multiple devices. During startup, the slave controllers initiate their start sequences after the master has completed its start sequence and all rails have reached regulation voltages. During shutdown, as soon as the master starts to sequence-off, it sends the shut-down signal to its slaves.

A shutdown on one or more of the master rails can initiate shutdowns of the slave devices. The master shutdowns can be initiated intentionally or by a fault condition. This method works to coordinate multiple controllers, but it does not enforce interdependency between rails within a single controller.

The PMBus specification implies that the power-good signal is active when ALL the rails in a controller are regulating at their programmed voltage. The UCD90910 allows GPIOs to be configured to respond to a desired subset of power-good signals.

PWM Outputs

FPWM1-8

Pins 17–24 can be configured as fast pulse-width modulators (FPWMs). The frequency range is 15.260 kHz to 125 MHz. FPWMs can be configured as closed-loop margining outputs, fan controllers or general-purpose PWMs.

Any FPWM pin not used as a PWM output can be configured as a GPIO. One FPWM in a pair can be used as a PWM output and the other pin can be used as a GPO. The FPWM pins are actively driven low from reset when used as GPOs.

The frequency settings for the FPWMs apply to pairs of pins:

- FPWM1 and FPWM2 – same frequency
- FPWM3 and FPWM4 – same frequency
- FPWM5 and FPWM6 – same frequency
- FPWM7 and FPWM8 – same frequency

If an FPWM pin from a pair is not used while its companion is set up to function, it is recommended to configure the unused FPWM pin as an active-low open-drain GPO so that it does not disturb the rest of the system. By setting an FPWM, it automatically enables the other FPWM within the pair if it was not configured for any other functionality.

The frequency for the FPWM is derived by dividing down a 250MHz clock. To determine the actual frequency to which an FPWM can be set, must divide 250MHz by any integer between 2 and $(2^{14}-1)$.

The FPWM duty cycle resolution is dependent on the frequency set for a given FPWM. Once the frequency is known the duty cycle resolution can be calculated as [Equation 1](#).

$$\text{Change per Step (\%)}_{\text{FPWM}} = \text{frequency} \div (250 \times 10^6 \times 16) \quad (1)$$

Take for an example determining the actual frequency and the duty cycle resolution for a 75MHz target frequency.

1. Divide 250MHz by 75MHz to obtain 3.33.
2. Round off 3.33 to obtain an integer of 3.
3. Divide 250MHz by 3 to obtain actual closest frequency of 83.333MHz.
4. Use [Equation 1](#) to determine duty cycle resolution to obtain 2.0833% duty cycle resolution.

PWM1-4

Pins 31, 32, 41, and 42 can be used as GPIOs or PWM outputs.

If configured as PWM outputs, then limitations apply:

- PWM1 has a fixed frequency of 10 kHz
- PWM2 has a fixed frequency of 1 kHz
- PWM3 and PWM4 frequencies can be 0.93 Hz to 7.8125 MHz.

The frequency for PWM3 and PWM4 is derived by dividing down a 15.625MHz clock. To determine the actual frequency to which these PWMs can be set, must divide 15.625MHz by any integer between 2 and $(2^{24}-1)$. The duty cycle resolution will be dependent on the set frequency for PWM3 and PWM4.

The PWM3 or PWM4 duty cycle resolution is dependent on the frequency set for the given PWM. Once the frequency is known the duty cycle resolution can be calculated as [Equation 2](#)

$$\text{Change per Step (\%)}_{\text{PWM3/4}} = \text{frequency} \div 15.625 \times 10^6 \quad (2)$$

To determine the closest frequency to 1MHz that PWM3 can be set to calculate as the following:

1. Divide 15.625MHz by 1MHz to obtain 15.625.
2. Round off 15.625 to obtain an integer of 16.
3. Divide 15.625MHz by 16 to obtain actual closest frequency of 976.563kHz.
4. Use [Equation 2](#) to determine duty cycle resolution to obtain 6.25% duty cycle resolution.

All frequencies below 238Hz will have a duty cycle resolution of 0.0015%.

Programmable Multiphase PWMs

The FPWMs can be aligned with reference to their phase. The phase for each FPWM is configurable from 0° to 359° . This provides flexibility in PWM-based applications such as synchronizing switch-mode power supplies, digital clock generation, and others. See an example of four FPWMs programmed to have phases at 0° , 90° , 180° and 270° ([Figure 18](#)).

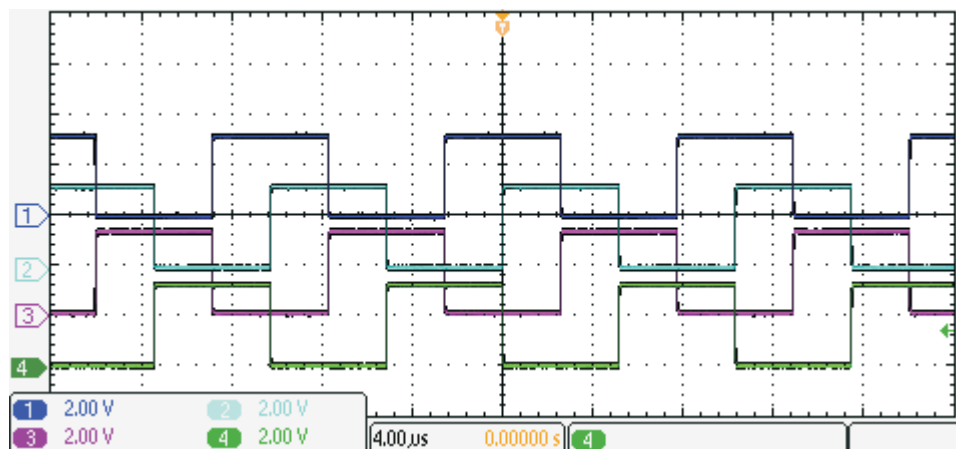

Figure 18. Multiphase PWMs

MARGINING

Margining is used in product validation testing to verify that the complete system works properly over all conditions, including minimum and maximum power-supply voltages, load range, ambient temperature range, and other relevant parameter variations. Margining can be controlled over PMBus using the OPERATION command or by configuring two GPIO pins as margin-EN and margin-UP/DOWN inputs. The MARGIN_CONFIG command in the *UCD90xxx Sequencer and System Health Controller PMBus Command Reference* describes different available margining options, including ignoring faults while margining and using closed-loop margining to trim the power-supply output voltage one time at power up.

Open-Loop Margining

Open-loop margining is done by connecting a power-supply feedback node to ground through one resistor and to the margined power supply output (V_{OUT}) through another resistor. The power-supply regulation loop responds to the change in feedback node voltage by increasing or decreasing the power-supply output voltage to return the feedback voltage to the original value. The voltage change is determined by the fixed resistor values and the voltage at V_{OUT} and ground. Two GPIO pins must be configured as open-drain outputs for connecting resistors from the feedback node of each power supply to V_{OUT} or ground.

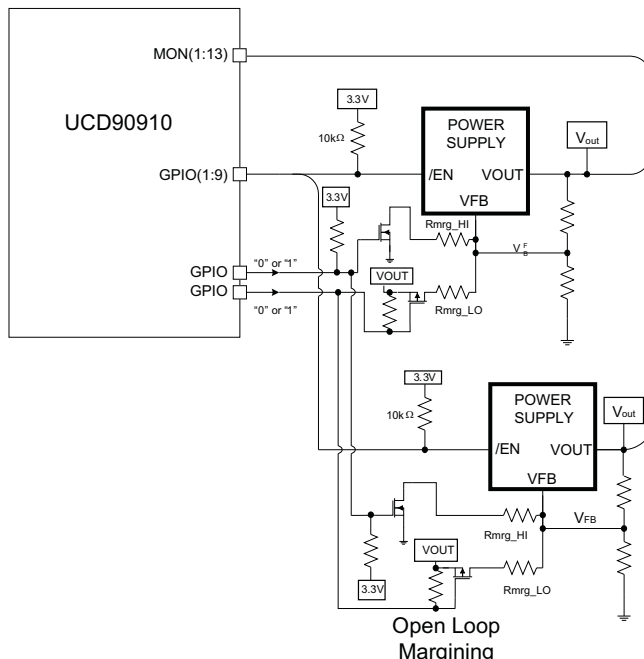

Figure 19. Open-Loop Margining

Closed-Loop Margining

Closed-loop margining uses a PWM or FPWM output for each power supply that is being margined. An external RC network converts the FPWM pulse train into a DC margining voltage. The margining voltage is connected to the appropriate power-supply feedback node through a resistor. The power-supply output voltage is monitored, and the margining voltage is controlled by adjusting the PWM duty cycle until the power-supply output voltage reaches the margin-low and margin-high voltages set by the user. The voltage setting resolutions will be the same that applies to the voltage measurement resolution (Table 2). The closed loop margining can operate in several modes (Table 5). Given that this closed-loop system has feed back through the ADC, the closed-loop margining accuracy will be dominated by the ADC measurement. For more details on configuring the UCD90910 for margining, see the *Voltage Margining Using the UCD9012x* application note (SLVA375).

Table 5. Closed Loop Margining Modes

Mode	Description
DISABLE	Margining is disabled.
ENABLE_TRI_STATE	When not margining, the PWM pin is set to high impedance state.
ENABLE_ACTIVE_TRIM	When not margining, the PWM duty-cycle is continuously adjusted to keep the voltage at VOUT_COMMAND.
ENABLE_FIXED_DUTY_CYCLE	When not margining, the PWM duty-cycle is set to a fixed duty-cycle.

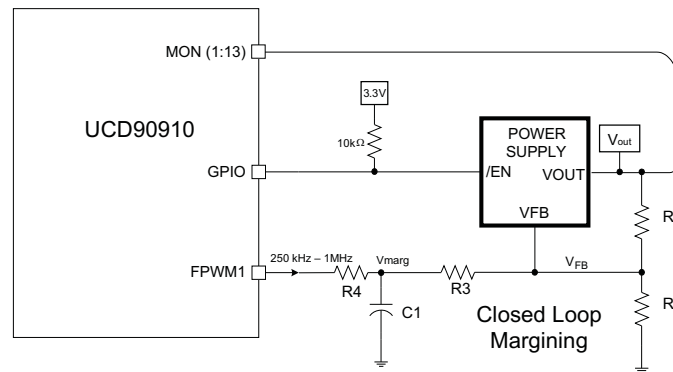
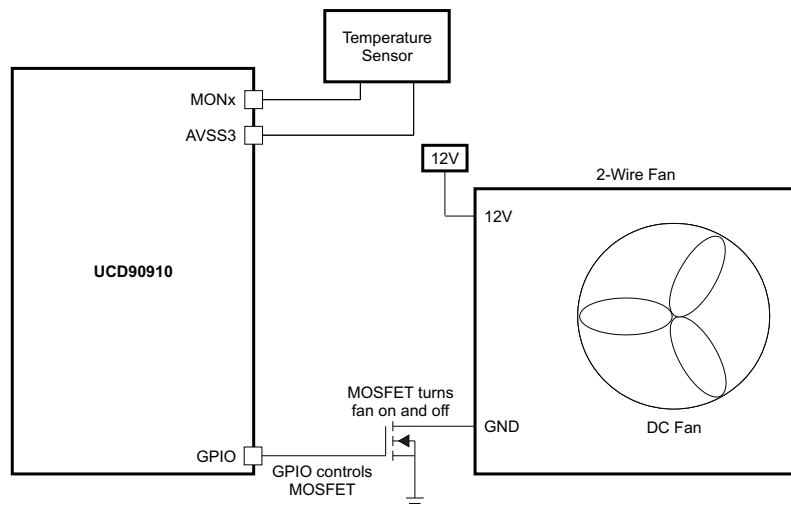

Figure 20. Closed-Loop Margining

FAN CONTROL

The UCD90910 can control and monitor up to ten two-, three- or four-wire fans. Up to ten GPI capable pins can be used as tachometer inputs. The number of fan tach pulses per revolution for each fan can be entered using the *Fusion GUI*. A fan speed-fault threshold can be set to trigger an alarm if the measured speed drops below a user-defined value.

The two- and three-wire fans are controlled by connecting the positive input of the fan to the specified supply voltage for the fan. The negative input of the fan is connected to the collector or drain of a transistor. The transistor is turned off and on using a GPIO pin. Four-wire fans can be controlled the same way. However, four-wire fans should use the fan PWM input (the fourth wire). It can be driven directly by one of the eight FPWMs or the two adjustable PWM outputs. The normal frequency range for the PWM input of a typical 4-wire fan is 15 kHz to 40 kHz, but the specifications for the fan confirm the interface procedure.



B0391-01

Figure 21. Two-Wire Fan Connection

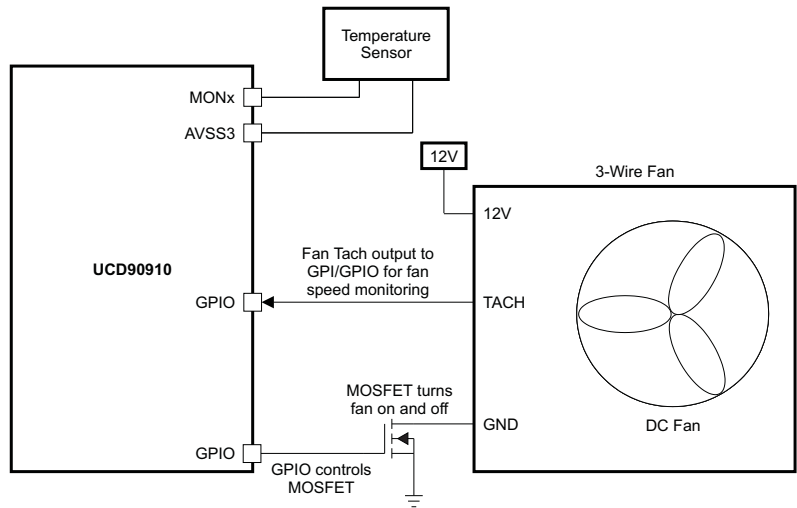

B0392-01

Figure 22. Three-Wire Fan Connection

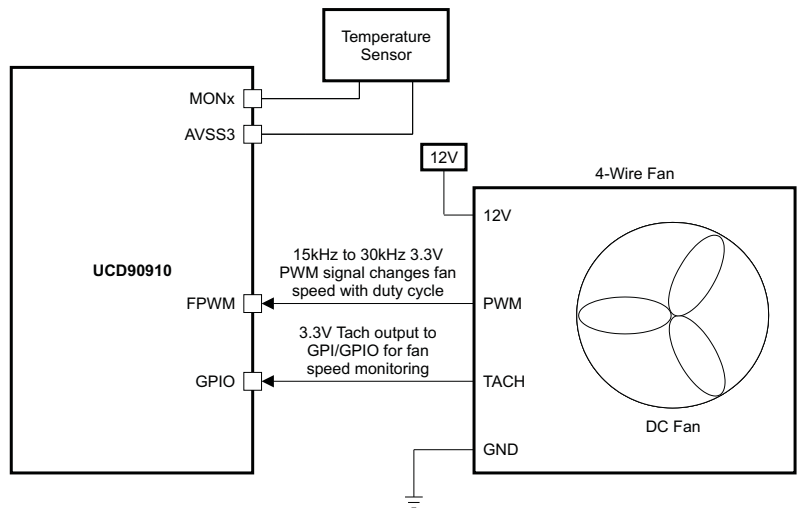

B0393-01

Figure 23. Four-Wire Fan Connection

The UCD90910 autocalibrate feature automatically finds and records the turn-on, turn-off and maximum speeds and duty cycles for any fan. Fans have a minimum speed at which they turn on, a turn-off speed that is usually slightly lower than the turn-on speed, and a maximum speed that occurs at slightly less than 100% duty cycle. Each speed has a PWM duty cycle that goes with it. Every fan is slightly different, even if the model numbers are the same. The built-in temperature-control algorithms use the actual measured operating speed range instead of 0 RPM to rated speed of the fan to improve the fan control algorithms. The user can choose whether to use autocalibrate or to manually enter the fan data. When configured, autocalibration will execute as soon as it is enabled and if the enable has been stored in data flash then it will occur after a device reset.

The UCD90910 can control up to ten independent fans as defined in the PMBus standard. When enabled, the FAN-PWM control output provides a digital signal with a configurable frequency and duty cycle, with a duty cycle that is set based on the FAN_COMMAND_1 PMBus command. The PWM can be set to frequencies between 1 Hz and 125 MHz based on the UCD90910 PWM type selected for the fan control. The duty cycle can be set from 0% to 100% with 1% resolution. Each fan has its own ramp rate. The ramp rate is effective for any adjustments to fan speed. The ramp rate is configured by indicating the change in duty cycle per each 500 ms elapsed to reach a targeted speed. The FAN-TACH fan-control input counts the number of transitions in the tachometer output from the fan in each 1-second interval. The tachometer can be read by issuing the READ_FAN_SPEED_1 command. The speed is returned in RPMs.

Fault limits can also be set for the tachometer speed by issuing the FAN_SPEED_FAULT_LIMIT command, and the status can be checked by issuing the STATUS_FAN_1_2 command. See the *UCD90xxx Sequencer and System Health Controller PMBus Command Reference* for a complete description of each command.

The UCD90910 also supports two fan control algorithms.

Hysteretic Fan Control

Temp_{ON} and Temp_{OFF} levels are input by the user. Temp_{ON} is higher than Temp_{OFF}. A GPIO pin is used to turn the fan or fans on at full speed when the monitored temperature reaches Temp_{ON} and to turn the fans off when the temperature drops below Temp_{OFF}.

Inputs: T_{ON}, T_{OFF}, T_{OT}, Update Interval, Rail where MEAS_TEMP is monitored, GPOx pin

- System starts up at t = 0 seconds
- MEAS_TEMP = 25°C → ambient temp
- GPO/PWM is low and Fan is off
- Check MEAS_TEMP every 1 second (or 250 msec)
- When MEAS_TEMP = T_{ON}, set GPO/PWM = 1 → turn fan on
- Leave GPO/PWM = 1 unless MEAS_TEMP < T_{OFF}
- If MEAS_TEMP is > T_{OT}, declare a fault and take the prescribed action.

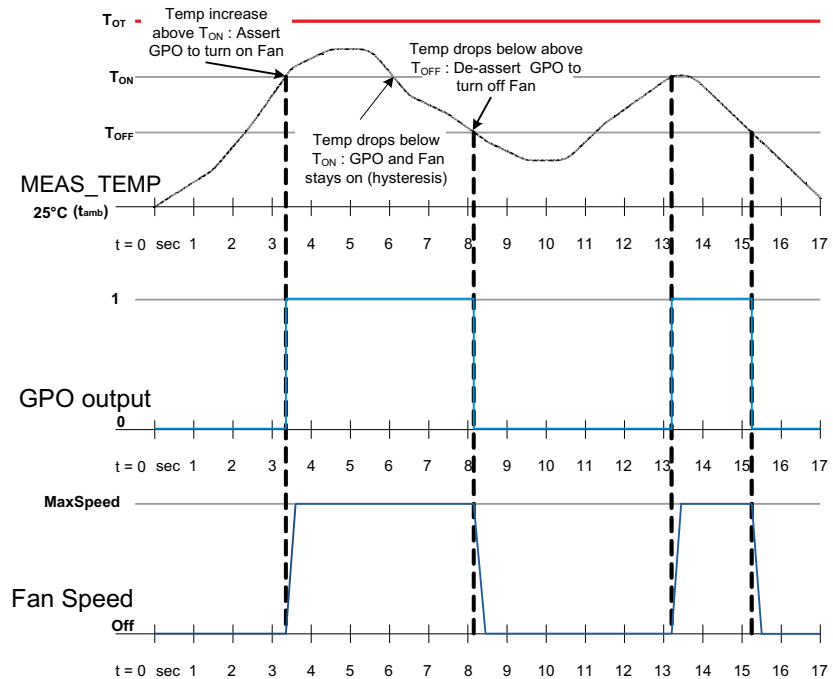

Figure 24. Hysteretic Temperature Control for 2- or 3-Wire Fans

Set Point Fan Control

The second algorithm (Figure 25) uses five control set points that each have a temperature and a fan speed. When the monitored temperature increases above one of the set point temperatures, the fan speed is increased to the corresponding set point value. When the monitored temperature drops below a set point temperature, the fan speed is reduced to the corresponding set point value. The ramp rate for speed can be selected, allowing the user to optimize fan performance and minimize audible noise. The ramp rate options are listed in Table 6

Table 6. Fan Ramp Rate for Speed

Change of Speed per Second
0.25%
0.5%
1%
2% (default)
4%
8%
16%
Apply new speed immediately

The fan speed is varied by changing the duty cycle of a PWM output. For two- and three-wire fans, as the fan is turned on and off, the inertia of the fan smooths out the fan speed changes, resulting in variable-speed operation. This approach can be taken with any fan, but would most likely be used with two- or three-wire fans at a PWM frequency in the 40-Hz to 80-Hz range. Four-wire fans would use the PWM input as described earlier in this section.

Inputs: T_{OT} , Updates Interval, Rail that MEAS_TEMP is being monitored on, PWM pin, PWM freq, PWM temp rate, FANTAC pin, 5x (TEMPn, SPEEDn) setpoints.

- System starts up at $t = 0$ seconds
- MEAS_TEMP = 25°C at ambient temp
- PWM DUTY_CYCLE = 0% and fan is off
- Check MEAS_TEMP every 250 ms (or 1 s)
- When MEAS_TEMP > TEMP1:
 - set SPEED_TARGET = SPEED1
 - increase DUTY_CYCLE to DUTY_CYCLE_ON
 - increase DUTY_CYCLE by ramp rate (10%/second) until SPEED = SPEED_TARGET
- When MEAS_TEMP > TEMP2:
 - set SPEED_TARGET = SPEED2
 - increase DUTY_CYCLE by ramp rate until SPEED = SPEED_TARGET
- Repeat as temperature is increased for each new setpoint
- If MEAS_TEMP > T_{OT} , declare a fault and take the prescribed action

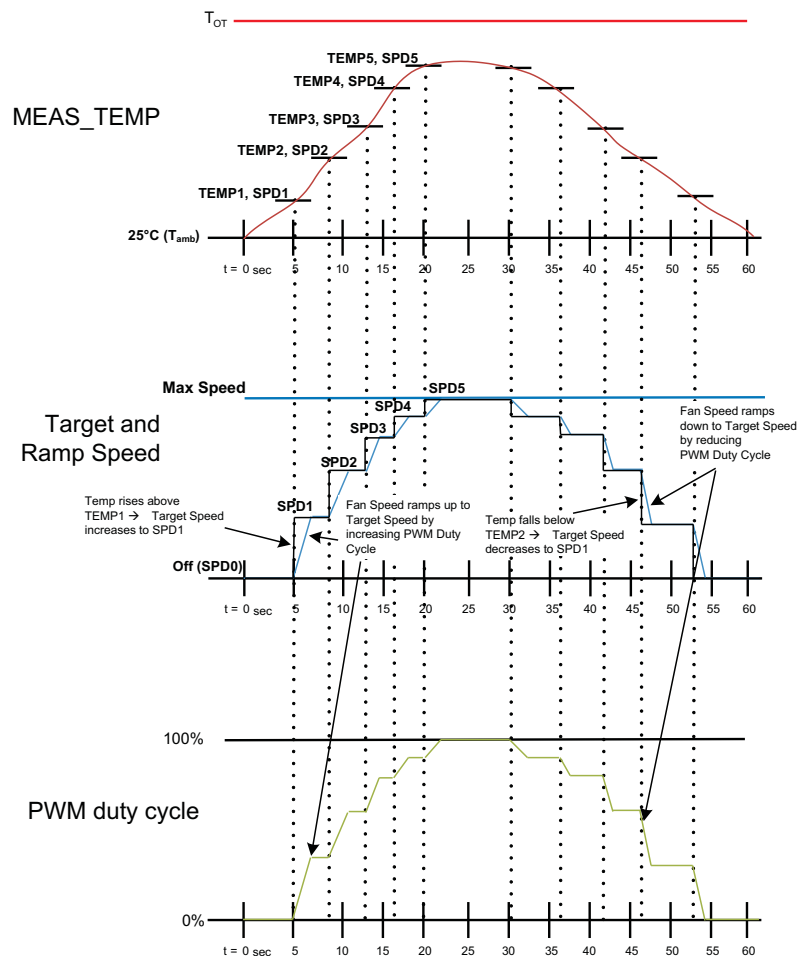

Figure 25. Temperature and Speed Set Point PWM Control for Four-Wire Fans

- If temperature drops - above TEMP4 to below TEMP3 for example
 - when MEAS_TEMP drops below TEMP4, maintain SPEED4 → do not change the DUTY_CYCLE
 - when MEAS_TEMP drops below TEMP3, set SPEED_TARGET = SPEED3
 - decrease DUTY_CYCLE by ramp rate (10%/second) until SPEED = SPEED_TARGET
- To turn the fan off when MEAS_TEMP < TEMP1, set SPEED1 = 0 RPM

EXAMPLE: MEAS_TEMP = 25°C at ambient temp:

- t = 0 to 5 sec: MEAS_TEMP increases from ambient to TEMP1 → increases SPEED_TARGET from SPD0 (Off) to SPD1 → increases DUTY_CYCLE from 0% to DUTYON (30%) → ACTUAL fan speed ramps up from 0 RPM to SPD1.
- t = 5 to 10 sec: MEAS_TEMP increases > TEMP2 → increases SPEED_TARGET from SPD1 to SPD2 → increases DUTY_CYCLE → ACTUAL fan speed ramps up from SPD1 to SPD2.
- t = 10 to 25 sec: MEAS_TEMP increases to > TEMP5 → SPEED_TARGET increases from SPD2 to SPD5 → DUTY_CYCLE ramps to DUTYMAX → ACTUAL fan speed increases SPD5.
- t = 25 to 30 sec: MEAS_TEMP stays > TEMP5 → SPEED_TARGET and DUTY_CYCLE do not change → ACTUAL fan speed stays at SPD5.
- t = 30 to 35 sec: MEAS_TEMP decreases to < TEMP4 → SPEED_TARGET drops to SPD4 and then to SPD3 → decreases DUTY_CYCLE → ACTUAL fan speed ramps down from SPD5 to SPD3.
- t = 35 to 60 sec: MEAS_TEMP decreases to < TEMP1 → SPEED_TARGET drops to SPD0 → decreases DUTY_CYCLE to DUTYOFF → ACTUAL fan speed ramps down from SPD3 to SPD0 (Off).

SYSTEM RESET SIGNAL

The UCD90910 can generate a programmable system-reset signal as part of sequence-on. The signal is created by programming a GPIO to remain deasserted until the voltage of a particular rail or combination of rails reach their respective POWER_GOOD_ON levels plus a programmable delay time [Figure 26](#). The system-reset delay duration can be programmed as shown in [Table 7](#). GPI states and Watchdog Timeouts can also be used to define the System Reset behavior. See the *UCD90xxx Sequencer and System Health Controller PMBus Command Reference* for complete definitions of SYSTEM_RESET_CONFIG command.

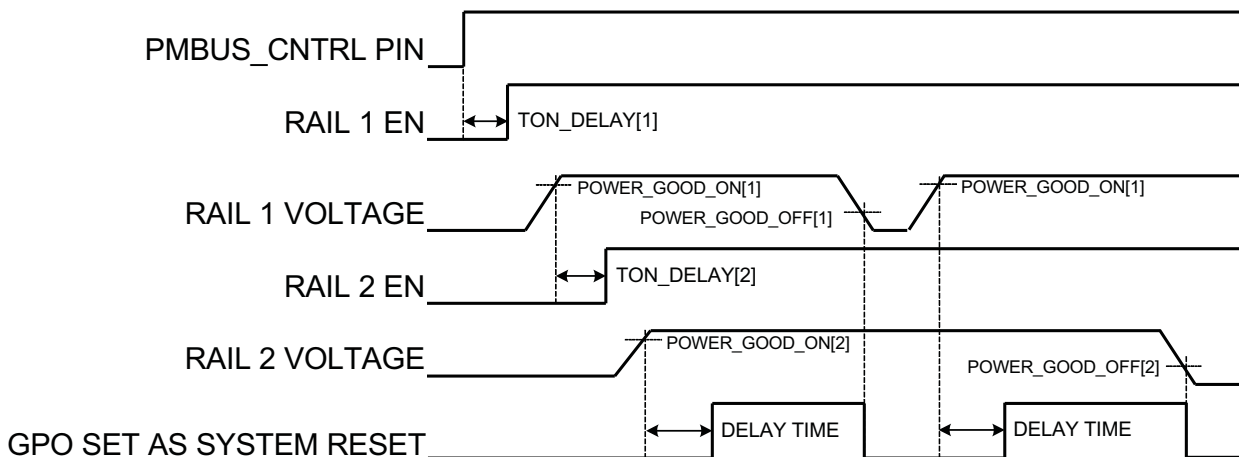

Figure 26. System Reset Timing Example

Table 7. System-Reset Delay Time

Delay Time
0 ms

Table 7. System-Reset Delay Time (continued)

Delay Time
1 ms
2 ms
4 ms
8 ms
16 ms
32 ms
64 ms
128 ms
256 ms
512 ms
1.02 s
2.05 s
4.10 s
8.19 s
16.38 s
32.8 s

WATCHDOG TIMER

A GPI and GPO can be configured as a watchdog timer (WDT). The WDT can be independent of power-supply sequencing or tied to a GPIO functioning as a watchdog output (WDO) that is configured to provide a system-reset signal. The WDT can be reset by toggling a watchdog input (WDI) pin or by writing to SYSTEM_WATCHDOG_RESET over I²C. The WDI and WDO pins are optional when using the watchdog timer. The WDI can be replaced by SYSTEM_WATCHDOG_RESET command and the WDO can be manifested through the Boolean Logic defined GPOs or through the System Reset function.

The WDT can be active immediately at power up or set to wait while the system initializes. [Table 8](#) lists the programmable wait times before the initial time-out sequence begins.

Table 8. WDT Initial Wait Time

WDT INITIAL WAIT TIME
0 ms
100 ms
200 ms
400 ms
800 ms
1.6 s
3.2 s
6.4 s
12.8 s
25.6 s
51.2 s
102 s
205 s
410 s
819 s
1638 s

The watchdog time-out is programmable from 0 to 2.55 s with a 10-ms step size. If the WDT times out, the UCD90910 can assert a GPIO pin configured as WDO that is separate from a GPIO defined as system-reset pin, or it can generate a system-reset pulse. After a time-out, the WDT is restarted by toggling the WDI pin or by writing to SYSTEM_WATCHDOG_RESET over I²C.

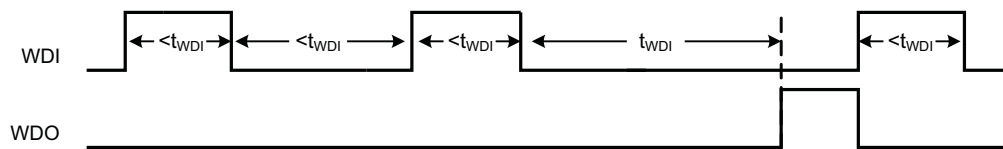

Figure 27. Timing of GPIOs Configured for Watchdog Timer Operation

DATA AND ERROR LOGGING TO FLASH MEMORY

The UCD90910 can log faults and the number of device resets to flash memory. Peak voltage, current, and temperature measurements are also stored for each rail. To reduce stress on the flash memory, a 30-second timer is started if a measured value exceeds the previously logged value. Only the highest value from the 30-second interval is written from RAM to flash.

Multiple faults can be stored in flash memory and can be accessed over PMBus to help debug power-supply bugs or failures. Each logged fault includes:

- Rail number
- Fault type
- Fault time since previous device reset
- Last measured rail voltage

The total number of device resets is also stored to flash memory. The value can be reset using PMBus.

With the brownout function enabled, the run-time clock value, peak monitor values, and faults are only logged to flash when a power-down is detected. The device run-time clock value is stored across resets or power cycles unless the brownout function is disabled, in which case the run-time clock is returned to zero after each reset.

It is also possible to update and calibrate the UCD90910 internal run-time clock via a PMBus host. For example, a host processor with a real-time clock could periodically update the UCD90910 run-time clock to a value that corresponds to the actual date and time. The host must translate the UCD90910 timer value back into the appropriate units, based on the usage scenario chosen. See the REAL_TIME_CLOCK command in the *UCD90xxx Sequencer and System Health Controller PMBus Command Reference* for more details.

BROWNOUT FUNCTION

The UCD90910 can be enabled to turn off all nonvolatile logging until a brownout event is detected. A brownout event occurs if V_{CC} drops below 2.9 V. In order to enable this feature, the user must provide enough local capacitance to deliver up to 80 mA (consider additional load based on GPOs sourcing external circuits such as LEDs) on for 5 ms while maintaining a minimum of 2.6 V at the device. If using the brownout circuit (Figure 28), then a schottky diode should be placed so that it blocks the other circuits that are also powered from the 3.3V supply.

With this feature enabled, the UCD90910 saves faults, peaks, and other log data to SRAM during normal operation of the device. Once a brownout event is detected, all data is copied from SRAM to Flash. Use of this feature allows the UCD90910 to keep track of a single run-time clock that spans device resets or system power down (rather than resetting the run time clock after device reset). It can also improve the UCD90910 internal response time to events, because Flash writes are disabled during normal system operation. This is an optional feature and can be enabled using the MISC_CONFIG command. For more details, see the *UCD90xxx Sequencer and System Health Controller PMBus Command Reference*.

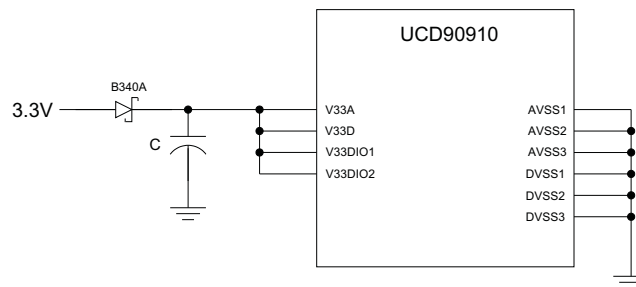

Figure 28. Brownout Circuit

PMBUS ADDRESS SELECTION

Two pins are allocated to decode the PMBus address. At power up, the device applies a bias current to each address-detect pin, and the voltage on that pin is captured by the internal 12-bit ADC. The PMBus address can be calculated from Equation 3:

$$\text{PMBus Address} = 12 \times \text{bin}(V_{\text{AD01}}) + \text{bin}(V_{\text{AD00}}) \quad (3)$$

where $\text{bin}(V_{\text{AD0x}})$ is the address bin for one of eight addresses as shown in Table 9. The address bins are defined by the MIN and MAX VOLTAGE RANGE (V). Each bin is a constant ratio of 1.25 from the previous bin. This method maintains the width of each bin relative to the tolerance of standard 1% resistors.

Table 9. PMBus Address Bins

ADDRESS BIN	VPMBus PMBus VOLTAGE RANGE (V)		RPMBus PMBus RESISTANCE (kΩ)
	MIN	MAX	
Open	2.226	3.300	
11	1.747	2.225	210
10	1.342	1.746	158
9	1.031	1.341	115
8	0.793	1.030	84.5
7	0.609	0.792	63.4
6	0.468	0.608	47.5
5	0.359	0.467	36.5
4	0.276	0.358	27.4
Short	0	0.097	

A low impedance (short) on either address pin that produces a voltage below the minimum voltage causes the PMBus address to default to address 126 (0x7E). A high impedance (open) on either address pin that produces a voltage above the maximum voltage also causes the PMBus address to default to address 126 (0x7E).

Address 0 is not used because it is the PMBus general-call address. Addresses 11 and 127 can not be used by this device or any other device that shares the PMBus with it, because those are reserved for manufacturing programming and test. It is recommended that address 126 not be used for any devices on the PMBus, because this is the address that the UCD90910 defaults to if the address lines are shorted to ground or left open. Table 10 summarizes which PMBus addresses can be used. Other SMBus/PMBus addresses have been assigned for specific devices. For a system with other types of devices connected to the same PMBus, see the SMBus device address assignments table in Appendix C of the latest version of the System Management Bus (SMBus) specification. The SMBus specification can be downloaded at <http://smbus.org/specs/smbus20.pdf>.

Table 10. PMBus Address Assignment Rules

Address	STATUS	Reason
0	Prohibited	SMBus general address call

Table 10. PMBus Address Assignment Rules (continued)

Address	STATUS	Reason
1-10	Available	
11	Avoid	Causes conflicts with other devices during program flash updates.
12	Prohibited	PMBus alert response protocol
13-125	Available	
126	For JTAG Use	Default value; may cause conflicts with other devices. Enables JTAG mode.
127	Prohibited	Used by TI manufacturing for device tests.

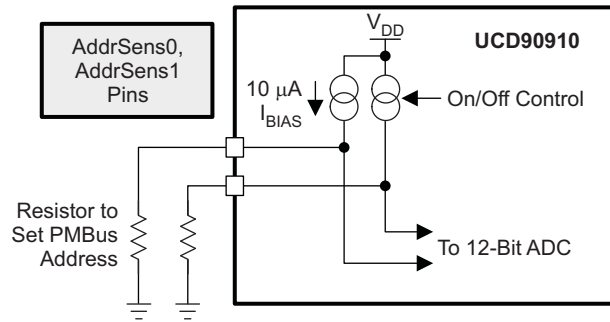

Figure 29. PMBus Address-Detection Method

CAUTION

Leaving the address in default state as 126 (0x7E) will enable the JTAG and not allow using the JTAG compatible pins (36-39) as GPIOs.

HIGH-VOLTAGE SUPPLY VOLTAGE REGULATOR

The UCD90910 requires 3.3 V to operate. It can be provided directly on the various V_{33x} pins using an external 3.3-V regulator, or it can be generated from a higher voltage using a built-in series regulator and an external transistor. The external transistor must be an NPN device with a beta of at least 40 and a V_{CE} rating appropriate for the high supply voltage. Figure 30 shows a typical circuit using the external series pass transistor. The NPN emitter output becomes the 3.3-V supply for the chip. A 4.7-µF bypass capacitor is required to stabilize the series regulator.

To design this circuit, Q must be selected first. Two things are important about this NPN transistor: rated power and beta value (β or h_{FE}). A higher beta allows R to be larger, which results in a more efficient circuit. Also, Q must be able to dissipate the power lost in it, as it is the pass element in this linear regulator. This power can be calculated from Equation 4:

$$P_{diss_Q} = (V_{in_max} - 3.3 V) \times I_{UCD90910} \tag{4}$$

I_{UCD90910} is the maximum current drawn by the controller on the V33A and V33D pins and is 50 mA for the UCD90910.

Once a transistor is selected, R must be sized based on the maximum input voltage. At V_{in_max}, the current through R is highest, because the base voltage is still held at ~4 V. At high V_{in}, the base current is also constant, as the emitter current is still the same. Thus at V_{in_max}, more current must be sunk by the V33FB pin. Good design practice dictates keeping the current sink required by the V33FB pin at high input voltage to half of the maximum rating for the V33FB pin, thus, 5 mA. This corresponds to a minimum value for R. Therefore R must be set by Equation 5:

$$R = \frac{V_{in_max} - 4 V}{5 mA + \left(\frac{I_{UCD90910}}{\beta + 1} \right)} \tag{5}$$

A maximum value of R corresponds to the minimum input voltage. This assumes that the V33FB pin is sinking no current and all the current through R flows into the base of the BJT. R must be below this value, or else the linear regulator does not operate reliably at low input voltage:

$$R < \frac{V_{in_max} - 4\text{ V}}{\frac{I_{UCD90910}}{\beta + 1}} \quad (6)$$

If the value of R from Equation 6 is less than the value of R from Equation 5, then a transistor with a larger beta must be chosen. For completion, the power lost in R can be calculated from Equation 7:

$$P_{diss_R} = \frac{(V_{in_max} - 4\text{ V})^2}{R} \quad (7)$$

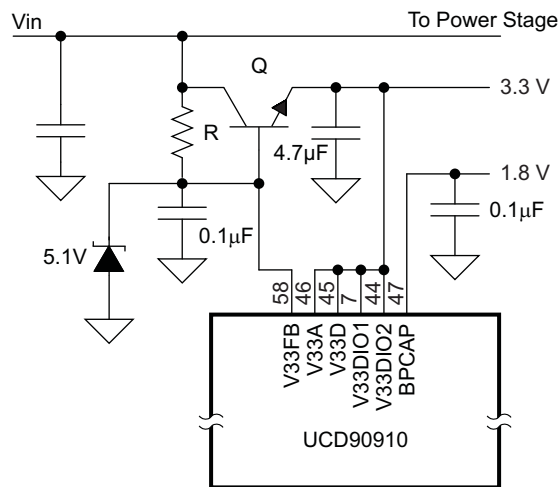

Figure 30. High-Voltage Supply With External Transistor

Some circuits in the device require 1.8 V, which is generated internally from the 3.3-V supply. This voltage requires a 0.1-µF to 1-µF bypass capacitor from BPCAP to ground.

An external LDO, such as the TPS715A33, may be used to provide the needed 3.3 V instead of the previously described regulator. In this case, the V33FB pin may simply be left floating.

DEVICE RESET

The UCD90910 has an integrated power-on reset (POR) circuit which monitors the supply voltage. At power up, the POR detects the V_{33D} rise. When V_{33D} is greater than V_{RESET} , the device comes out of reset.

The device can be forced into the reset state by an external circuit connected to the \overline{RESET} pin. A logic-low voltage on this pin for longer than t_{RESET} holds the device in reset. It comes out of reset within 1 ms after \overline{RESET} is released and can return to a logic-high level. To avoid an erroneous trigger caused by noise, a pullup resistor to 3.3 V is recommended.

Any time the device comes out of reset, it begins an initialization routine that lasts about 20 ms. During the initialization routine, the FPWM pins are held low, and all other GPIO and GPI pins are open-circuit. At the end of initialization, the device begins normal operation as defined by the device configuration.

DEVICE CONFIGURATION AND PROGRAMMING

From the factory, the device contains the sequencing and monitoring firmware. It is also configured so that all GPOs are high-impedance (except for FPWM/GPIO pins 17-24, which are driven low), with no sequencing or fault-response operation. See *Configuration Programming of UCD Devices*, available from the *Documentation & Help Center* that can be selected from the *Fusion GUI* Help menu, for full UCD90910 configuration details.

After the user has designed a configuration file using *Fusion GUI*, there are three general device-configuration programming options:

1. Devices can be programmed in-circuit by a host microcontroller using PMBus commands over I²C (see the *UCD90xxx Sequencer and System Health Controller PMBus Command Reference*). Each parameter write replaces the data in the associated memory (RAM) location. After all the required configuration data has been sent to the device, it is transferred to the associated nonvolatile memory (data flash) by issuing a special command, STORE_DEFAULT_ALL. This method is how the *Fusion GUI* normally reads and writes a device configuration.
2. The *Fusion GUI* (Figure 31) can create a PMBus or I²C command script file that can be used by the I²C master to configure the device.

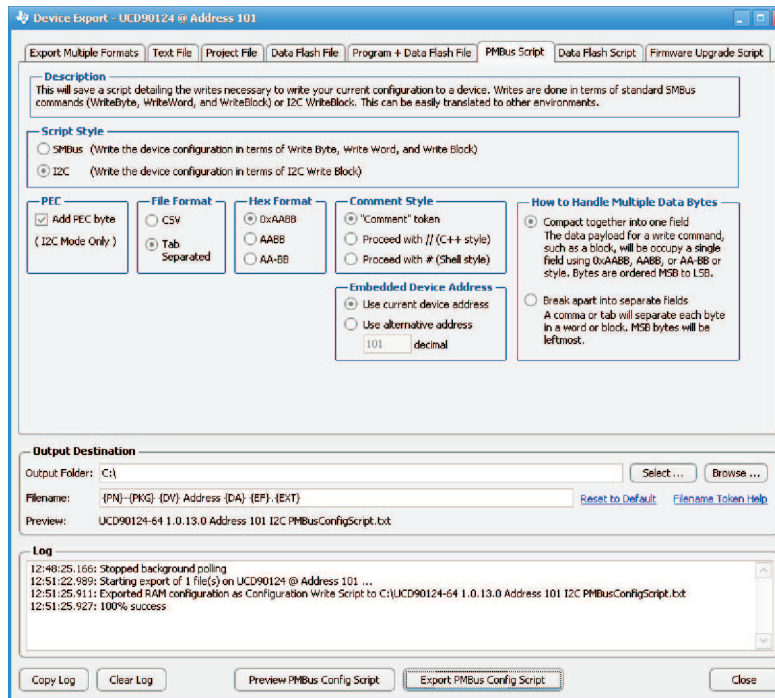

Figure 31. Fusion GUI PMBus Configuration Script Export Tool

3. Another in-circuit programming option is for the *Fusion GUI* to create a data flash image from the configuration file (Figure 32). The configuration files can be exported in Intel Hex, Serial Vector Format (SVF) and S-record. The image file can be downloaded into the device using I²C or JTAG. The *Fusion GUI* tools can be used on-board if the *Fusion GUI* can gain ownership of the target board I²C bus.

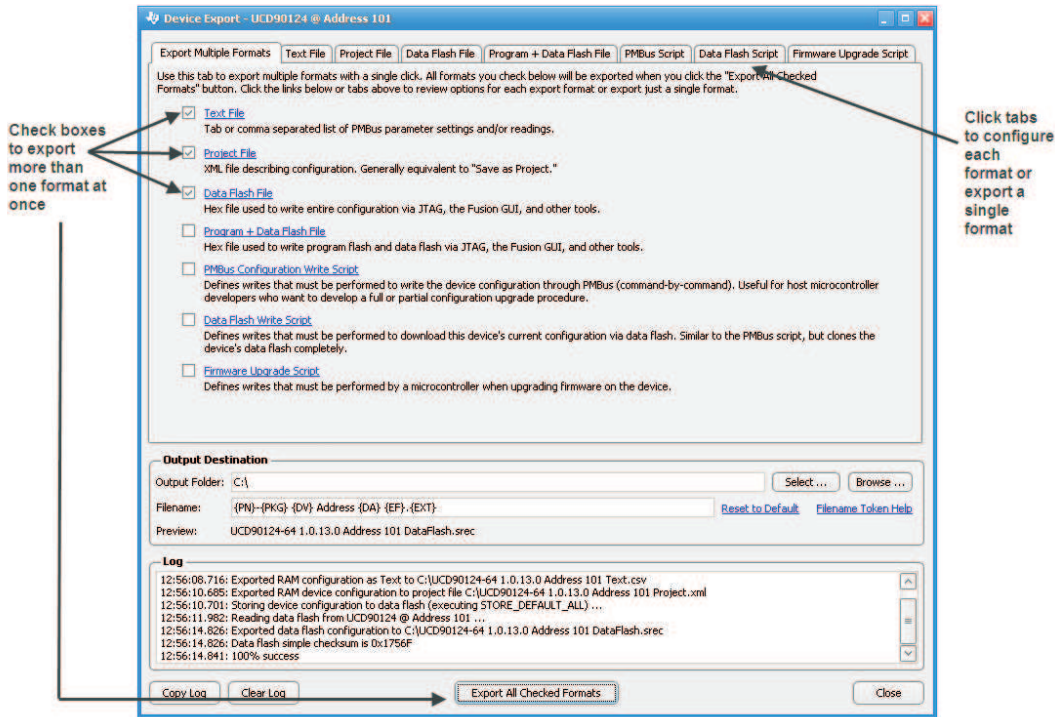

Figure 32. Fusion GUI Device Configuration Export Tool

Devices can be programmed off-board using the *Fusion GUI* tools or a dedicated device programmer. For small runs, a ZIF socketed board with an I²C header can be used with the standard *Fusion GUI* or manufacturing GUI. The *Fusion GUI* can also create a data flash file that can then be loaded into the UCD90910 using a dedicated device programmer.

To configure the device over I²C or PMBus, the UCD90910 must be powered. The PMBus clock and data pins must be accessible and must be pulled high to the same V_{DD} supply that powers the device, with pullup resistors between 1 kΩ and 2 kΩ. Care should be taken to not introduce additional bus capacitance (<100 pF). The user configuration can be written to data flash using a gang programmer via JTAG or I²C before the device is installed in circuit. To use I²C, the clock and data lines must be multiplexed or the device addresses must be assigned by socket. The *Fusion GUI* tools can be used for socket addressing. Pre-programming can also be done using a single device test fixture.

Table 11. Configuration Options

	Data Flash via JTAG	Data Flash via I ² C	PMBus Commands via I ² C
Off-Board Configuration	Data Flash Export (.svf type file)	Data Flash Export (.srec or hex type file)	Project file I ² C/PMBus script
	Dedicated programmer	Fusion GUI tools (with exclusive bus access via USB to I ² C adapter)	Fusion GUI tools (with exclusive bus access via USB to I ² C adapter)
On-Board Configuration	Data flash export	Fusion GUI tools (with exclusive bus access via USB to I ² C adapter)	Fusion GUI tools (with exclusive bus access via USB to I ² C adapter)
	IC		

The advantages of off-board configuration include:

- Does not require access to device I²C bus on board.
- Once soldered on board, full board power is available without further configuration.
- Can be partially reconfigured once the device is mounted.

Full Configuration Update while in Normal Mode

Although performing a full configuration of the UCD90910 in a controlled test setup is recommended, there may be times in which it is required to update the configuration while the device is in an operating system. Updating the full configuration based on methods listed in DEVICE CONFIGURATION AND PROGRAMMING section while the device is in an operating system can be challenging because these methods do not permit the UCD90910 to operate as required by application during the programming. During described methods the GPIOs may not be in the desired states which can disable rails that provide power to the UCD90910. To overcome this, the UCD90910 has the capability to allow full configuration update while still operating in normal mode.

Updating the full configuration while in normal mode will consist of disabling data flash write protection, erasing the data flash, writing the data flash image and reset the device. It is not required to reset the device immediately but make note that the UCD90910 will continue to operate based on previous configuration with fault logging disabled until reset. See *Configuration Programming of UCD Devices*, available from the *Documentation & Help Center* that can be selected from the *Fusion GUI* Help menu, for details.

JTAG INTERFACE

The JTAG port can be used for production programming. Four of the six JTAG pins can also be used as GPIOs during normal operation. See the *Pin Functions* table at the beginning of the document and [Table 3](#) for a list of the JTAG signals and which can be used as GPIOs. The JTAG port is compatible with the IEEE Standard 1149.1-1990, IEEE Standard Test-Access Port and Boundary Scan Architecture specification. Boundary scan is not supported on this device.

The JTAG interface can provide an alternate interface for programming the device. It is disabled by default in order to enable the GPIO pins with which it is multiplexed. There are two conditions under which the JTAG interface is enabled:

1. On power-up if the data flash is blank, allowing JTAG to be used for writing the configuration parameters to a programmed device with no PMBus interaction
2. When address 126 (0x7E) is detected at power up. A short to ground or an open condition on either address pin will cause an address 126 (0x7E) to be generated which enables JTAG mode.

The Fusion GUI can create SVF files (See [DEVICE CONFIGURATION AND PROGRAMMING](#) section) based on a given data flash configuration which can be used to program the desired configuration by JTAG. For Boundary Scan Description Language (BSDL) file that supports the UCD90910 see the product folder in [www.ti.com](#).

INTERNAL FAULT MANAGEMENT AND MEMORY ERROR CORRECTION (ECC)

The UCD90910 verifies the firmware checksum at each power up. If it does not match, then the device waits for I²C commands but does not execute the firmware. A device configuration checksum verification is also performed at power up. If it does not match, the factory default configuration is loaded. The PMBALERT# pin is asserted and a flag is set in the status register. The error-log checksum validates the contents of the error log to make sure that section of flash is not corrupted.

There is an internal firmware watchdog timer. If it times out, the device resets so that if the firmware program is corrupted, the device goes back to a known state. This is a normal device reset, so all of the GPIO pins are open-drain and the FPWM pins are driven low while the device is in reset. Checks are also done on each parameter that is passed, to make sure it falls within the acceptable range.

Error-correcting code (ECC) is used to improve data integrity and provide high-reliability storage of Data Flash contents. ECC uses dedicated hardware to generate extra check bits for the user data as it is written into the Flash memory. This adds an additional six bits to each 32-bit memory word stored into the Flash array. These extra check bits, along with the hardware ECC algorithm, allow for any single-bit error to be detected and corrected when the Data Flash is read.

APPLICATION INFORMATION

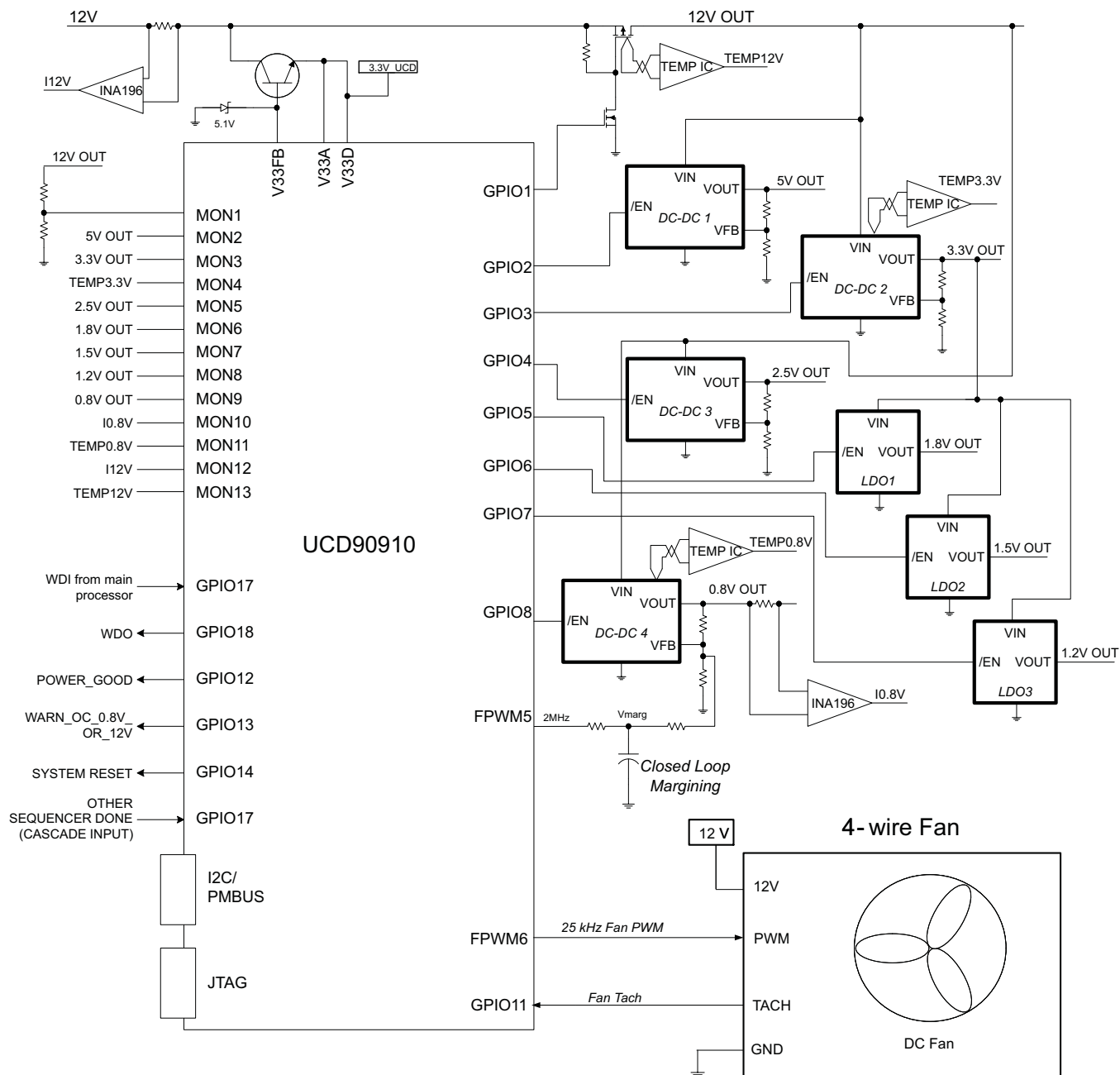

Figure 33. Typical Application Schematic

Layout guidelines

The thermal pad provides a thermal and mechanical interface between the device and the printed circuit board (PCB). While device power dissipation is not of primary concern, a more-robust thermal interface can help the internal temperature sensor provide a better representation of PCB temperature. Connect the exposed thermal pad of the PCB to the device V_{SS} pins and provide at least a 4 × 4 pattern of PCB vias to connect the thermal pad and V_{SS} pins to the circuit ground on other PCB layers.

For supply-voltage decoupling, provide power-supply pin bypass to the device as follows:

- 0.1- μ F, X7R ceramic in parallel with 0.01- μ F, X7R ceramic at pin 47 (BPCAP)
- 0.1- μ F, X7R ceramic in parallel with 4.7- μ F, X5R ceramic at pins 44 (V_{33DI02}) and 45 (V_{33D})

- 0.1- μ F, X7R ceramic at pin 7 (V_{33DIO1})
- 0.1- μ F, X7R ceramic in parallel with 4.7- μ F, X5R ceramic at pin 46 (V_{33A})

Depending on use and application of the various GPIO signals used as digital outputs, some impedance control may be desired to quiet fast signal edges. For example, when using the FPWM pins for fan control or voltage margining, the pin is configured as a digital clock signal. Route these signals away from sensitive analog signals. Good design practice provides a series impedance of 20 Ω to 33 Ω at the signal source to slow fast digital edges.

Estimating ADC Reporting Accuracy

The UCD90910 uses a 12-bit ADC and an internal 2.5-V reference (V_{REF}) to convert MON pin inputs into digitally reported voltages. The least-significant bit (LSB) value is $V_{LSB} = V_{REF}/2^N$ where $N = 12$, resulting in a $V_{LSB} = 610 \mu\text{V}$. The error in the reported voltage is a function of the ADC linearity errors and any variations in V_{REF} . The total unadjusted error (E_{TUE}) for the UCD90910 ADC is ± 5 LSB, and the variation of V_{REF} is $\pm 0.5\%$ from 0°C to 125°C and $\pm 1\%$ from -40°C to 125°C . V_{TUE} is calculated as $V_{LSB} \times E_{TUE}$. The total reported voltage error is the sum of the reference-voltage error and V_{TUE} . At lower monitored voltages, V_{TUE} dominates reported error, whereas at higher monitored voltages, the tolerance of V_{REF} dominates the reported error. Reported error can be calculated using Equation 8, where REFTOL is the tolerance of V_{REF} , V_{ACT} is the actual voltage being monitored at the MON pin, and V_{REF} is the nominal voltage of the ADC reference.

$$\text{RPT}_{\text{ERR}} = \left(\frac{1 + \text{REFTOL}}{V_{\text{ACT}}} \right) \times \left(\frac{V_{\text{REF}} \times E_{\text{TUE}}}{4096} + V_{\text{ACT}} \right) - 1 \quad (8)$$

From Equation 8, for temperatures from 0°C to 125°C , if $V_{\text{ACT}} = 0.5 \text{ V}$, then $\text{RPT}_{\text{ERR}} = 1.11\%$. If $V_{\text{ACT}} = 2.2 \text{ V}$, then $\text{RPT}_{\text{ERR}} = 0.64\%$. For the full operating temperature range of -40°C to 125°C , if $V_{\text{ACT}} = 0.5 \text{ V}$, then $\text{RPT}_{\text{ERR}} = 1.62\%$. If $V_{\text{ACT}} = 2.2 \text{ V}$, then $\text{RPT}_{\text{ERR}} = 1.14\%$.

PACKAGING INFORMATION

Orderable part number	Status (1)	Material type (2)	Package Pins	Package qty Carrier	RoHS (3)	Lead finish/ Ball material (4)	MSL rating/ Peak reflow (5)	Op temp (°C)	Part marking (6)
UCD90910RGCR	Active	Production	VQFN (RGC) 64	2000 LARGE T&R	Yes	NIPDAU	Level-3-260C-168 HR	-40 to 125	UCD90910
UCD90910RGCR.A	Active	Production	VQFN (RGC) 64	2000 LARGE T&R	Yes	NIPDAU	Level-3-260C-168 HR	-40 to 125	UCD90910
UCD90910RGCR.B	Active	Production	VQFN (RGC) 64	2000 LARGE T&R	Yes	NIPDAU	Level-3-260C-168 HR	-40 to 125	UCD90910
UCD90910RGCT	Active	Production	VQFN (RGC) 64	250 SMALL T&R	Yes	NIPDAU	Level-3-260C-168 HR	-40 to 125	UCD90910
UCD90910RGCT.A	Active	Production	VQFN (RGC) 64	250 SMALL T&R	Yes	NIPDAU	Level-3-260C-168 HR	-40 to 125	UCD90910
UCD90910RGCT.B	Active	Production	VQFN (RGC) 64	250 SMALL T&R	Yes	NIPDAU	Level-3-260C-168 HR	-40 to 125	UCD90910

(1) **Status:** For more details on status, see our [product life cycle](#).

(2) **Material type:** When designated, preproduction parts are prototypes/experimental devices, and are not yet approved or released for full production. Testing and final process, including without limitation quality assurance, reliability performance testing, and/or process qualification, may not yet be complete, and this item is subject to further changes or possible discontinuation. If available for ordering, purchases will be subject to an additional waiver at checkout, and are intended for early internal evaluation purposes only. These items are sold without warranties of any kind.

(3) **RoHS values:** Yes, No, RoHS Exempt. See the [TI RoHS Statement](#) for additional information and value definition.

(4) **Lead finish/Ball material:** Parts may have multiple material finish options. Finish options are separated by a vertical ruled line. Lead finish/Ball material values may wrap to two lines if the finish value exceeds the maximum column width.

(5) **MSL rating/Peak reflow:** The moisture sensitivity level ratings and peak solder (reflow) temperatures. In the event that a part has multiple moisture sensitivity ratings, only the lowest level per JEDEC standards is shown. Refer to the shipping label for the actual reflow temperature that will be used to mount the part to the printed circuit board.

(6) **Part marking:** There may be an additional marking, which relates to the logo, the lot trace code information, or the environmental category of the part.

Multiple part markings will be inside parentheses. Only one part marking contained in parentheses and separated by a "~" will appear on a part. If a line is indented then it is a continuation of the previous line and the two combined represent the entire part marking for that device.

Important Information and Disclaimer: The information provided on this page represents TI's knowledge and belief as of the date that it is provided. TI bases its knowledge and belief on information provided by third parties, and makes no representation or warranty as to the accuracy of such information. Efforts are underway to better integrate information from third parties. TI has taken and continues to take reasonable steps to provide representative and accurate information but may not have conducted destructive testing or chemical analysis on incoming materials and chemicals. TI and TI suppliers consider certain information to be proprietary, and thus CAS numbers and other limited information may not be available for release.

In no event shall TI's liability arising out of such information exceed the total purchase price of the TI part(s) at issue in this document sold by TI to Customer on an annual basis.

TAPE AND REEL INFORMATION

QUADRANT ASSIGNMENTS FOR PIN 1 ORIENTATION IN TAPE

*All dimensions are nominal

Device	Package Type	Package Drawing	Pins	SPQ	Reel Diameter (mm)	Reel Width W1 (mm)	A0 (mm)	B0 (mm)	K0 (mm)	P1 (mm)	W (mm)	Pin1 Quadrant
UCD90910RGCR	VQFN	RGC	64	2000	330.0	16.4	9.3	9.3	1.1	12.0	16.0	Q2
UCD90910RGCT	VQFN	RGC	64	250	180.0	16.4	9.3	9.3	1.1	12.0	16.0	Q2

TAPE AND REEL BOX DIMENSIONS

*All dimensions are nominal

Device	Package Type	Package Drawing	Pins	SPQ	Length (mm)	Width (mm)	Height (mm)
UCD90910RGCR	VQFN	RGC	64	2000	367.0	367.0	38.0
UCD90910RGCT	VQFN	RGC	64	250	210.0	185.0	35.0

GENERIC PACKAGE VIEW

RGC 64

VQFN - 1 mm max height

9 x 9, 0.5 mm pitch

PLASTIC QUAD FLATPACK - NO LEAD

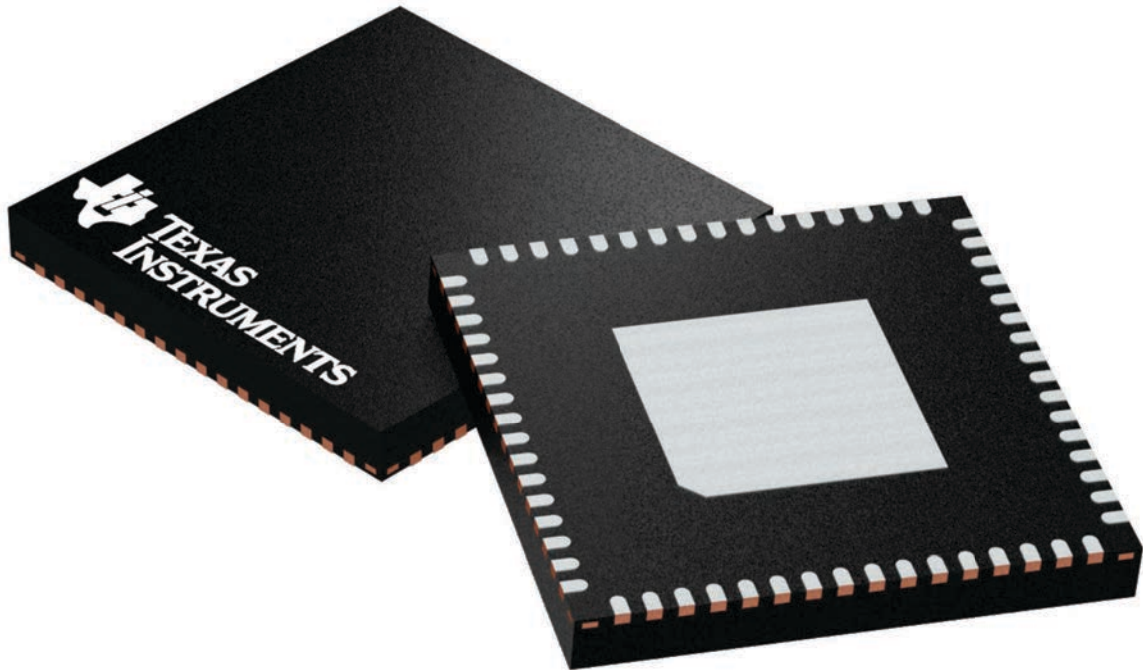

Images above are just a representation of the package family, actual package may vary.
Refer to the product data sheet for package details.

4224597/A

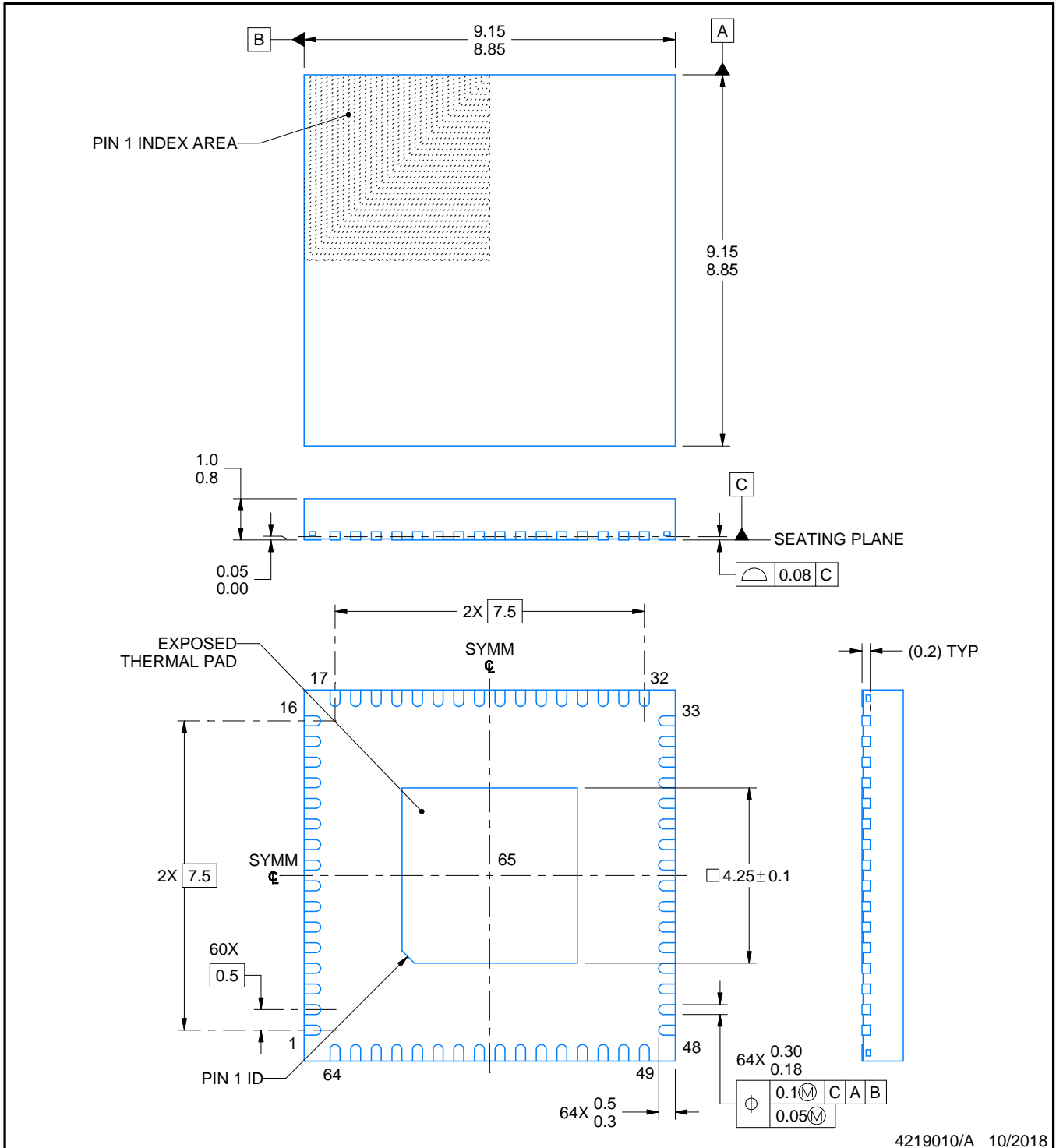
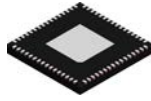

4219010/A 10/2018

NOTES:

1. All linear dimensions are in millimeters. Any dimensions in parenthesis are for reference only. Dimensioning and tolerancing per ASME Y14.5M.
2. This drawing is subject to change without notice.
3. The package thermal pad must be soldered to the printed circuit board for thermal and mechanical performance.

EXAMPLE BOARD LAYOUT

RGC0064B

VQFN - 1 mm max height

PLASTIC QUAD FLATPACK - NO LEAD

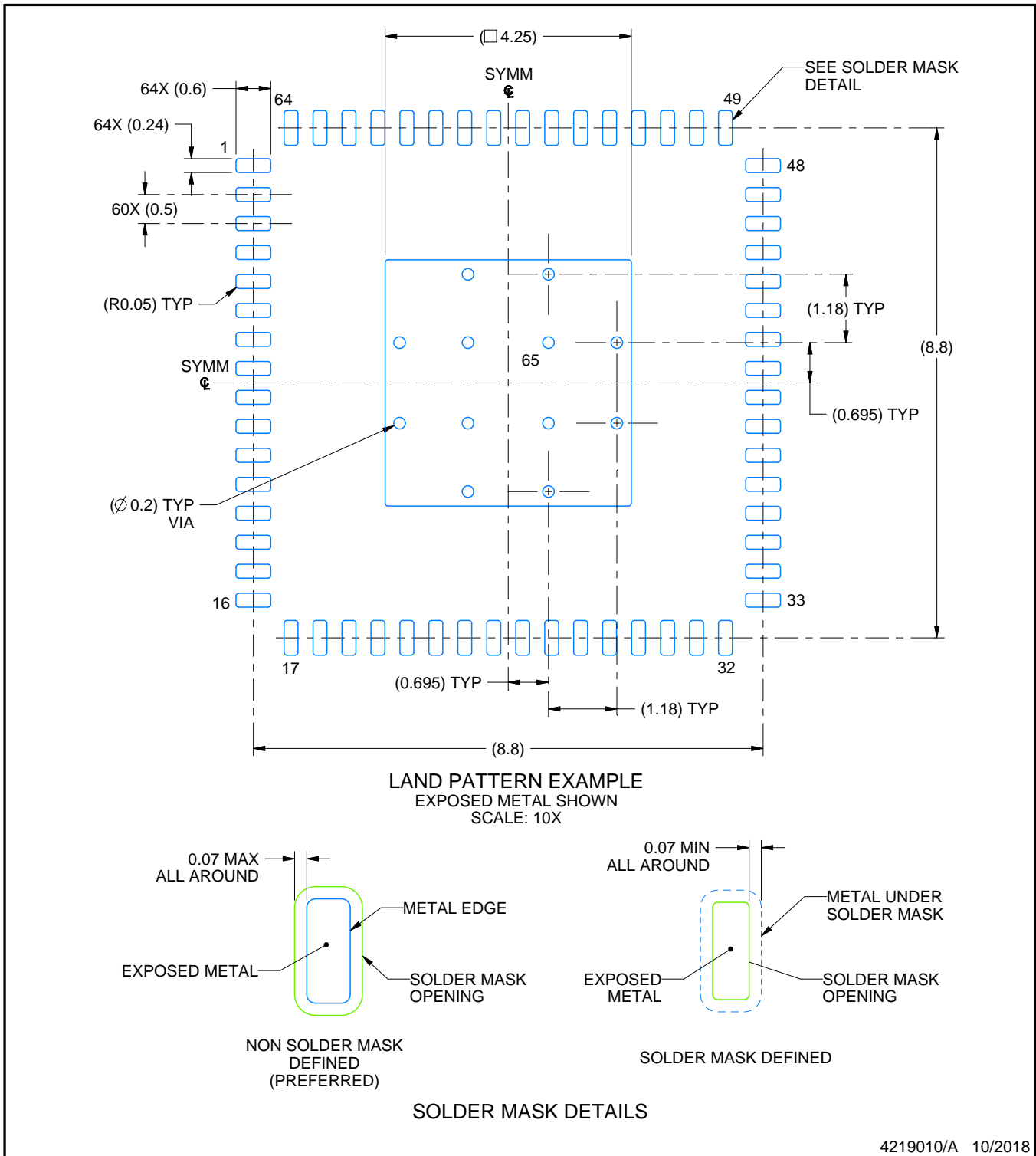

4219010/A 10/2018

NOTES: (continued)

- This package is designed to be soldered to a thermal pad on the board. For more information, see Texas Instruments literature number SLUA271 (www.ti.com/lit/slua271).
- Vias are optional depending on application, refer to device data sheet. If any vias are implemented, refer to their locations shown on this view. It is recommended that vias under paste be filled, plugged or tented.

EXAMPLE STENCIL DESIGN

RGC0064B

VQFN - 1 mm max height

PLASTIC QUAD FLATPACK - NO LEAD

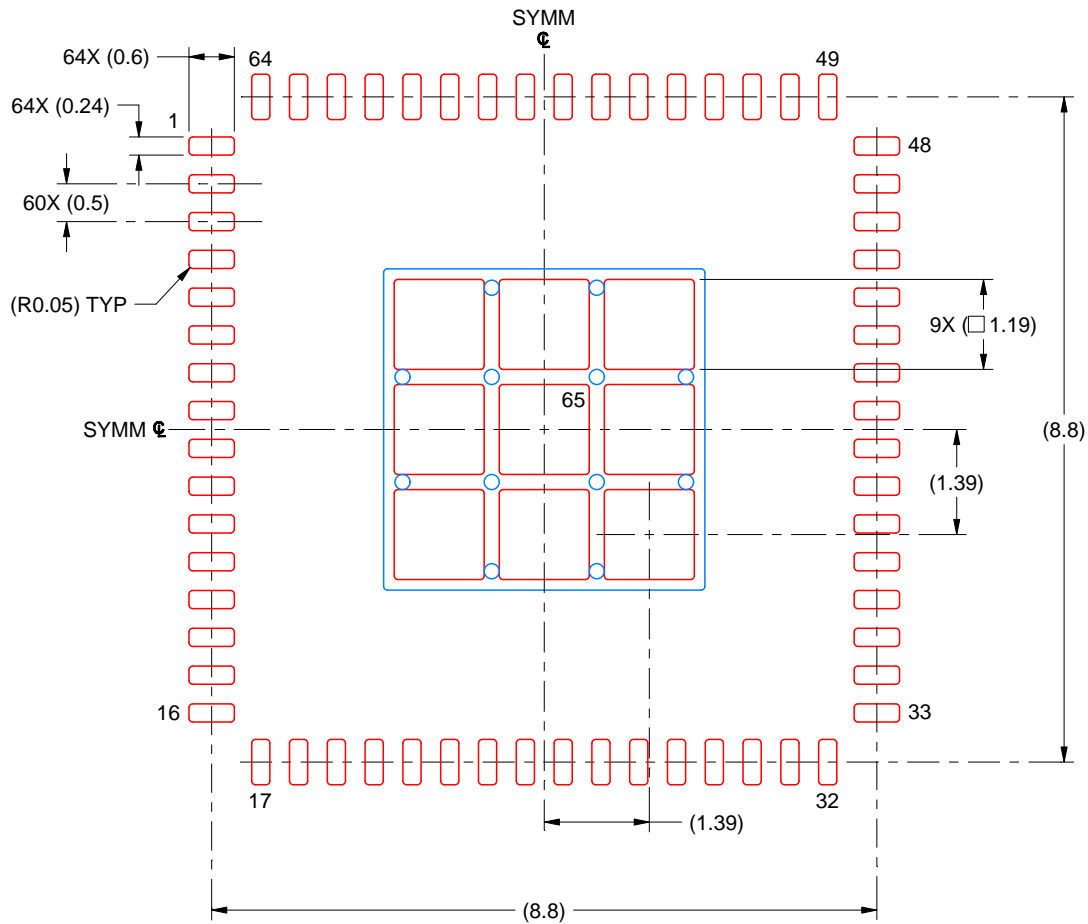

SOLDER PASTE EXAMPLE
BASED ON 0.125 MM THICK STENCIL
SCALE: 10X

EXPOSED PAD 65
71% PRINTED SOLDER COVERAGE BY AREA UNDER PACKAGE

4219010/A 10/2018

NOTES: (continued)

6. Laser cutting apertures with trapezoidal walls and rounded corners may offer better paste release. IPC-7525 may have alternate design recommendations.

IMPORTANT NOTICE AND DISCLAIMER

TI PROVIDES TECHNICAL AND RELIABILITY DATA (INCLUDING DATASHEETS), DESIGN RESOURCES (INCLUDING REFERENCE DESIGNS), APPLICATION OR OTHER DESIGN ADVICE, WEB TOOLS, SAFETY INFORMATION, AND OTHER RESOURCES "AS IS" AND WITH ALL FAULTS, AND DISCLAIMS ALL WARRANTIES, EXPRESS AND IMPLIED, INCLUDING WITHOUT LIMITATION ANY IMPLIED WARRANTIES OF MERCHANTABILITY, FITNESS FOR A PARTICULAR PURPOSE OR NON-INFRINGEMENT OF THIRD PARTY INTELLECTUAL PROPERTY RIGHTS.

These resources are intended for skilled developers designing with TI products. You are solely responsible for (1) selecting the appropriate TI products for your application, (2) designing, validating and testing your application, and (3) ensuring your application meets applicable standards, and any other safety, security, regulatory or other requirements.

These resources are subject to change without notice. TI grants you permission to use these resources only for development of an application that uses the TI products described in the resource. Other reproduction and display of these resources is prohibited. No license is granted to any other TI intellectual property right or to any third party intellectual property right. TI disclaims responsibility for, and you fully indemnify TI and its representatives against any claims, damages, costs, losses, and liabilities arising out of your use of these resources.

TI's products are provided subject to [TI's Terms of Sale](#), [TI's General Quality Guidelines](#), or other applicable terms available either on ti.com or provided in conjunction with such TI products. TI's provision of these resources does not expand or otherwise alter TI's applicable warranties or warranty disclaimers for TI products. Unless TI explicitly designates a product as custom or customer-specified, TI products are standard, catalog, general purpose devices.

TI objects to and rejects any additional or different terms you may propose.

Copyright © 2025, Texas Instruments Incorporated

Last updated 10/2025