

ADS54J54 Quad Channel 14-Bit 500 MSPS ADC

1 Features

- 4 Channel, 14-Bit 500 MSPS ADC
- Analog input buffer with high impedance input
- Flexible input clock buffer with divide by 1/2/4
- 1.25 V_{PP} Differential full-scale input
- JESD204B Serial interface
 - Subclass 1 compliant up to 5 Gbps
 - 1 Lane Per ADC up to 250 Msps
 - 2 Lanes Per ADC up to 500 Msps
- 64-Pin QFN Package (9 mm x 9 mm)
- Key specifications:
 - Power dissipation: 875 mW/ch
 - Input bandwidth (3 dB): 900 MHz
 - Aperture jitter: 98 fs rms
 - Channel isolation: 85 dB
 - Performance at $f_{in} = 170$ MHz at 1.25 V_{PP}, 1lane 2x Decimation –1 dBFS
 - SNR: 67.2 dBFS
 - SFDR: 85 dBc HD2,3; 95 dBFS non-HD2,3
 - Performance at $f_{in} = 370$ MHz at 1.25 V_{PP}, 2lane no Decimation –1 dBFS
 - SNR: 64.7 dBFS
 - SFDR: 75 dBc HD2,3; 83 dBFS non-HD2,3

2 Applications

- Multi-Carrier, Multi-Mode, Multi-Band Cellular Receivers
 - TDD-LTE, FDD-LTE, CDMA, WCDMA, CMA2k, GSM
- Microwave backhaul
- Wireless repeaters
- Distributed antenna systems (DAS)
- Broadband wireless
- Ultra-wide band software defined radio
- Data acquisition
- Test and measurement instrumentation
- Signal intelligence and jamming
- Radar and satellite systems
- Cable infrastructure

3 Description

The ADS54J54 is a low power, wide bandwidth 14-bit 500 MSPS quad channel analog-to-digital converter (ADC). It supports the JESD204B serial interface with data rates up to 5 Gbps supporting 1 or 2 lanes per ADC. The buffered analog input provides uniform input impedance across a wide frequency range while minimizing sample-and-hold glitch energy. A sampling clock divider allows more flexibility for system clock architecture design. The ADS54J54 provides excellent spurious-free dynamic range (SFDR) over a large input frequency range with very low power consumption. Optional 2x Decimation Filter provides high-pass or low-pass filter modes.

Device Information⁽¹⁾

PART NUMBER	PACKAGE	BODY SIZE (NOM)
ADS54J54	VQFN (64)	9.00mm x 9.00mm

(1) For all available packages, see the orderable addendum at the end of the data sheet.

Simplified Schematic

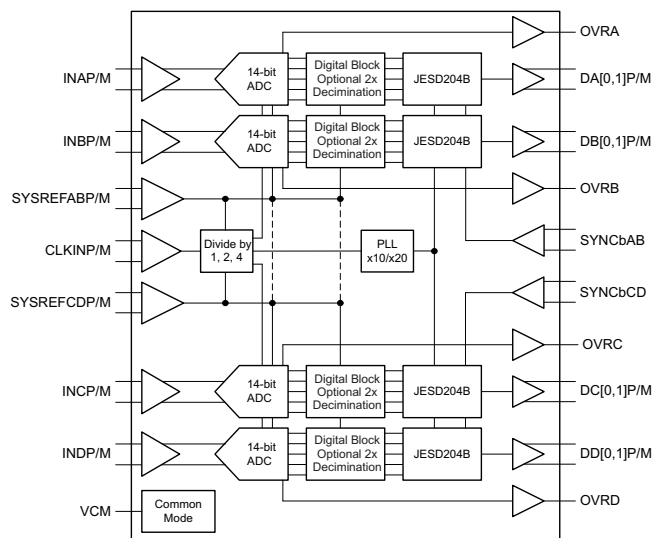

Table of Contents

1 Features	1	7.2 Functional Block Diagram	23
2 Applications	1	7.3 Feature Description	24
3 Description	1	7.4 Device Functional Modes	33
4 Revision History	2	7.5 Programming	35
5 Pin Configuration and Functions	3	7.6 Register Maps	36
6 Specifications	5	8 Application and Implementation	53
6.1 Absolute Maximum Ratings	5	8.1 Application Information	53
6.2 ESD Ratings	5	8.2 Typical Application	53
6.3 Recommended Operating Conditions	5	8.3 Design Requirements	54
6.4 Thermal Information	5	8.4 Detailed Design Procedure	54
6.5 Electrical Characteristics	7	8.5 Application Curves	55
6.6 Electrical Characteristics: 250 MSPS Output, 2x Decimation Filter	8	9 Power Supply Recommendations	56
6.7 Electrical Characteristics: 500 MSPS Output	9	10 Layout	56
6.8 Electrical Characteristics: Sample Clock Timing Characteristics	9	10.1 Layout Guidelines	56
6.9 Electrical Characteristics: Digital Outputs	10	10.2 Layout Example	56
6.10 Timing Requirements	10	11 Device and Documentation Support	58
6.11 Reset Timing	10	11.1 Trademarks	58
6.12 Typical Characteristics	13	11.2 Electrostatic Discharge Caution	58
7 Detailed Description	23	11.3 Glossary	58
7.1 Overview	23	12 Mechanical, Packaging, and Orderable Information	58

4 Revision History

Changes from Original (January 2015) to Revision A	Page
• Added list item in <i>Device and Register Initialization</i> : "Write the data in Table 5 to.."	33
• Added Table 5	33

5 Pin Configuration and Functions

ADS54J54
RGC 64 Pin Package
Top View

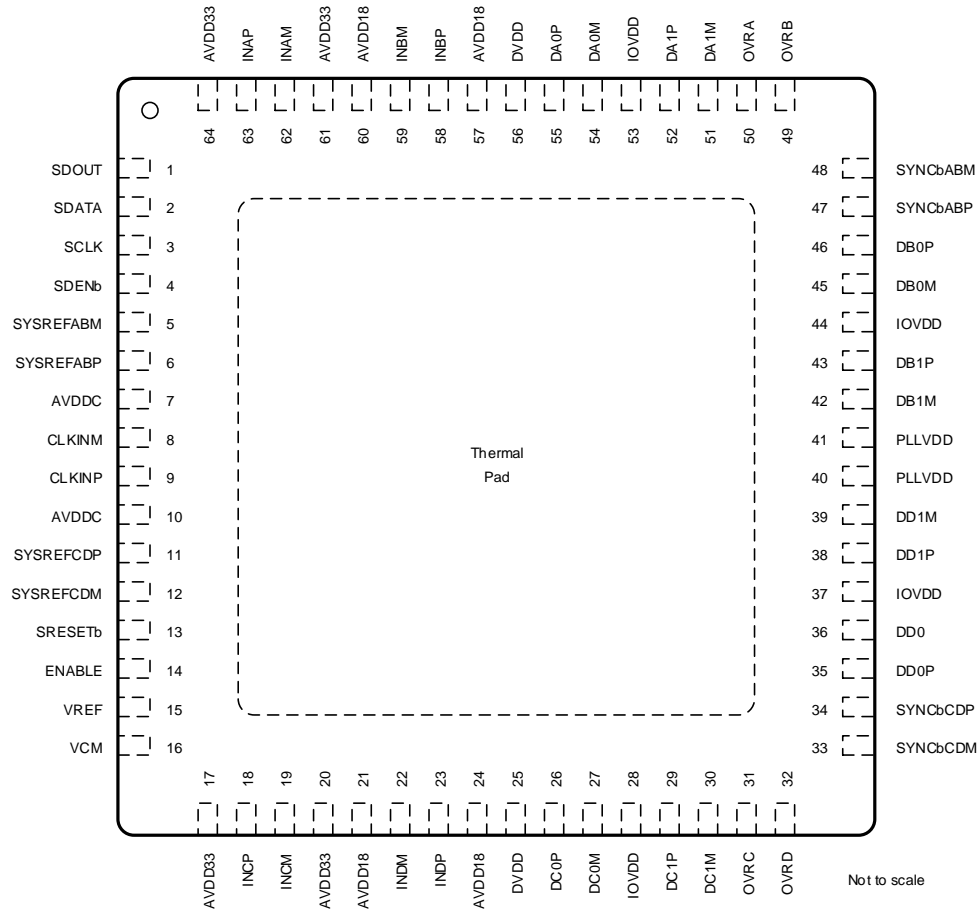

Pin Functions

PIN		I/O	DESCRIPTION
NAME	NO.		
INPUT OR REFERENCE			
INAP, INAM	63, 62	I	Differential analog input for channel A
INBP, INBM	58, 59	I	Differential analog input for channel B
INCP, INCM	18, 19	I	Differential analog input for channel C
INDP, INDM	23, 22	I	Differential analog input for channel D
VCM	16	O	Common mode output voltage to bias analog inputs, Vcm = 2.0 V
VREF	15	O	Voltage reference output. A 0.1- μ F bypass capacitor to ground close to the pin is recommended
CLOCK/SYNC			
CLKINP, CLKINM	9, 8	I	Differential clock input for channel
SYSREFABP, SYSREFABM	6, 5	I	LVDS input with internal 100- Ω termination. External SYSREF input for channels A, B, C, and D
SYSREFCDP, SYSREFCDM	11, 12	I	LVDS input with internal 100- Ω termination. External SYSREF input for channels C and D if output rate of channel A/B is different from channel C/D.

Pin Functions (continued)

PIN		I/O	DESCRIPTION
NAME	NO.		
CONTROL OR SERIAL			
ENABLE	14	I	Chip enable. Active high. Power down functionality can be configured through SPI register setting and exercised using the ENABLE pin. Internal 51-k Ω pulldown resistor.
SCLK	3	I	Serial interface clock input
SDATA	2	I/O	Bidirectional serial data in 3-pin mode. In 4-pin interface, the SDATA pin is an input only.
SDENb	4	I	Serial interface enable
SDOUT	1	O	Serial interface data output
SRESETb	13	I	Hardware reset. Active low. Initializes internal registers during high to low transition. This pin has an internal 51-k Ω pullup resistor.
DATA OUTPUT INTERFACE			
DA[0,1]P, DA[0,1]M	55, 54, 52, 51	O	JESD204B output interface for channel A
DB[0,1]P, DB[0,1]M	46, 45, 43, 42	O	JESD204B output interface for channel B
DC[0,1]P, DC[0,1]M	26, 27, 29, 30	O	JESD204B output interface for channel C
DD[0,1]P, DD[0,1]M	35, 36, 38, 39	O	JESD204B output interface for channel D
OVRA	50	I/O	Fast over-range indicator channel A.
OVRA	49	O	Fast over-range indicator channel B.
OVRC	31	I/O	Fast over-range indicator channel C.
OVRA	32	O	Fast over-range indicator channel D.
SYNCbABP, SYNCbABM	47, 48	I	SYNCb input for JESD204B interface for channel A/B, internal 100- Ω termination
SYNCbCDP, SYNCbCDM	34, 33	I	SYNCb input for JESD204B interface for channel C/D, internal 100- Ω termination
POWER SUPPLY			
AVDDC	7, 10	I	Clock 1.8-V power supply
AVDD18	21, 24, 57, 60	I	Analog 1.9-V power supply
AVDD33	17, 20, 61, 64	I	Analog 3.3-V power supply
DVDD	25, 56	I	Digital 1.8-V power supply
GND	PowerPAD™	I	Ground
IOVDD	28, 37, 44, 53	I	JESD204B output interface 1.8-V power supply
PLLVDD	40, 41	I	PLL 1.8-V power supply

6 Specifications

6.1 Absolute Maximum Ratings

over operating free-air temperature (unless otherwise noted)⁽¹⁾

		MIN	MAX	UNIT
Supply voltage	AVDD33	-0.3	3.6	V
	AVDD18	-0.3	2.1	
	AVDDC	-0.3	2.1	
	DVDD	-0.3	2.1	
	IOVDD	-0.3	2.1	
	PLLVDD	-0.3	2.1	
Voltage between AGND and DGND		-0.3	0.3	V
Voltage applied to input pins	INAP, INBP, INCP, INDP, INAM, INBM, INCM, INDM	-0.3	3	V
	CLKINP, CLKINM	-0.3	AVDD18 + 0.3 V	
	SYNCbABP, SYNCbABM, SYNCbCDP, SYNCbCDM	-0.3	AVDD18 + 0.3 V	
	SYSREFABP, SYSREFABM, SYSREFCDP, SYSREFCDM	-0.3	AVDD18 + 0.3 V	
	SCLK, SDENb, SDATA, SRESETb, ENABLE	-0.3	DVDD + 0.5 V	
Operating free-air temperature, T _A		-40	85	°C
Operating junction temperature, T _J ⁽²⁾			125	°C
Storage temperature, T _{stg}		-65	150	°C

- (1) Stresses beyond those listed as *absolute maximum ratings* may cause permanent damage to the device. These are stress ratings only, and functional operation of the device at these or any other conditions beyond those indicated as *recommended operating conditions* is not implied. Exposure to absolute-maximum-rated conditions for extended periods may affect device reliability.
- (2) Prolonged use at this junction temperature may increase the device failure-in-time (FIT) rate.

6.2 ESD Ratings

		VALUE	UNIT
V _(ESD) Electrostatic discharge	Human-body model (HBM), per ANSI/ESDA/JEDEC JS-001 ⁽¹⁾	±1000	V
	Charged-device model (CDM), per JEDEC specification JESD22-C101 ⁽²⁾	±500	

- (1) JEDEC document JEP155 states that 500-V HBM allows safe manufacturing with a standard ESD control process.
- (2) JEDEC document JEP157 states that 250-V CDM allows safe manufacturing with a standard ESD control process.

6.3 Recommended Operating Conditions

over operating free-air temperature range (unless otherwise noted)

		MIN	NOM	MAX	UNIT
ADC clock frequency		250		500	MSPS
Resolution		14		14	bits
Supply	AVDD33	3.15	3.3	3.45	V
	AVDD18	1.8	1.9	2	
	AVDDC	1.7	1.8	1.9	
	DVDD	1.7	1.8	1.9	
	IOVDD	1.7	1.8	1.9	
	PLLVDD	1.7	1.8	1.9	
T _A	Operating free-air temperature	-40		85	°C
T _J	Operating junction temperature			125	°C

6.4 Thermal Information

Thermal Metric ⁽¹⁾		RGC (64 PINS)	UNIT
R _{θJA}	Junction-to-ambient thermal resistance	23.5	°C/W

- (1) For more information about traditional and new thermal metrics, see the [Semiconductor and IC Package Thermal Metrics](#) application report.

Thermal Information (continued)

Thermal Metric ⁽¹⁾		RGC (64 PINS)	UNIT
$R_{\Theta JC(top)}$	Junction-to-case, top	7.0	°C/W
$R_{\Theta JB}$	Junction-to-board thermal resistance	2.6	°C/W
ϕ_{JT}	Junction-to-top of package	0.1	°C/W
ϕ_{JB}	Junction-to-board characterization parameter	2.6	°C/W
$R_{\Theta JC(bot)}$	Junction-to-case, bottom	0.3	°C/W

6.5 Electrical Characteristics

Typical values at $T_A = 25^\circ\text{C}$, full temperature range is $T_{\text{MIN}} = -40^\circ\text{C}$ to $T_{\text{MAX}} = 85^\circ\text{C}$, ADC sampling rate = 500 MSPS, 50% clock duty cycle, AVDD33 = 3.3 V; AVDD18 = 1.9 V; AVDDC, DVDD, IOVDD, PLLVDD = 1.8 V, –1-dBFS differential input, unless otherwise noted.

PARAMETER		TEST CONDITIONS	MIN	TYP	MAX	UNIT
POWER SUPPLY						
I_{AVDD33}	3.3-V analog supply current			500		mA
I_{AVDD18}	1.9-V analog supply current			320		mA
I_{AVDDC}	1.8-V clock supply current			18		mA
I_{DVDD}	1.8-V digital supply current	4-channel decimation filter		323		mA
		4-channel bypass digital mode		324		
		2-channel decimation filter, 2-channel bypass digital mode		324		
I_{IOVDD}	I/O voltage supply current	2 lanes per ADC		373		mA
		1 lane per ADC		185		
I_{PLLVDD}	PLL voltage supply current			42		mA
Pdis	Total power dissipation	4-channel bypass digital mode		3.46	3.7	W
		4-channel decimation filter		3.34		
		4-channel decimation filter, 1 lane per ADC		3.27		
		2-channel decimation filter, 2-channel bypass digital mode		3.51		
Deep sleep mode power				791		mW
Wake-up time from deep sleep mode		SNR > 60 dB		1.4		ms
Light sleep mode power				1.68		W
Wake-up time from light sleep mode		SNR > 60 dB		8		μs
ANALOG INPUTS						
Differential input full-scale			1	1.25	1.5	V _{pp}
Input common mode voltage				$V_{\text{CM}} \pm 50 \text{ mV}$		V
Input resistance	Differential at DC			1		k Ω
Input capacitance	Each input to GND			2.75		pF
VCM	Common mode voltage output			2.18		V
Analog input bandwidth (–3 dB)				900		MHz
INL	Integral nonlinearity			± 3		LSB
DNL	Dynamic nonlinearity		–1	± 0.9		LSB
Gain error				$\pm 2.24\%$		
Offset error				± 1.91		mV
CHANNEL-TO-CHANNEL ISOLATION						
Crosstalk ⁽¹⁾	Near channel	$f_{\text{IN}} = 170 \text{ MHz}$		85		dB
	Far channel	$f_{\text{IN}} = 170 \text{ MHz}$		95		
CLOCK INPUT						
Input clock frequency			250		2000 ⁽²⁾	MHz
Input clock amplitude			0.4	1.5		V _{pp}
Input clock duty cycle			45%	50%	55%	
Internal clock biasing				0.9		V

(1) Crosstalk is measured with a –1-dBFS input signal on aggressor channel and no input on victim channel.

(2) CLK / 4 mode

6.6 Electrical Characteristics: 250 MSPS Output, 2x Decimation Filter

Typical values at $T_A = 25^\circ\text{C}$, full temperature range is $T_{\text{MIN}} = -40^\circ\text{C}$ to $T_{\text{MAX}} = 85^\circ\text{C}$, ADC sampling rate = 500 MSPS, 50% clock duty cycle, AVDD33 = 3.3 V; AVDD18 = 1.9 V; AVDDC, DVDD, IOVDD, PLLVDD = 1.8 V, -1-dBFS differential input, unless otherwise noted.

PARAMETER		TEST CONDITIONS	MIN	TYP	MAX	UNIT
SNR	Signal-to-noise ratio	$f_{\text{IN}} = 10 \text{ MHz}$		68.3		dBFS
		$f_{\text{IN}} = 100 \text{ MHz}$		68.2		
		$f_{\text{IN}} = 170 \text{ MHz}$		67.2		
		$f_{\text{IN}} = 310 \text{ MHz}$		67.6		
		$f_{\text{IN}} = 450 \text{ MHz}$		66.8		
HD2	Second harmonic distortion	$f_{\text{IN}} = 10 \text{ MHz}$		85		dBc
		$f_{\text{IN}} = 100 \text{ MHz}$		85		
		$f_{\text{IN}} = 170 \text{ MHz}$		85		
		$f_{\text{IN}} = 310 \text{ MHz}$		85		
		$f_{\text{IN}} = 450 \text{ MHz}$		75		
HD3	Third harmonic distortion	$f_{\text{IN}} = 10 \text{ MHz}$		85		dBc
		$f_{\text{IN}} = 100 \text{ MHz}$		85		
		$f_{\text{IN}} = 170 \text{ MHz}$		85		
		$f_{\text{IN}} = 310 \text{ MHz}$		85		
		$f_{\text{IN}} = 450 \text{ MHz}$		85		
SFDR (Non-HD2, Non-HD3)	Spur free dynamic range (excluding HD2 and HD3)	$f_{\text{IN}} = 10 \text{ MHz}$		95		dBc
		$f_{\text{IN}} = 100 \text{ MHz}$		95		
		$f_{\text{IN}} = 170 \text{ MHz}$		95		
		$f_{\text{IN}} = 310 \text{ MHz}$		90		
		$f_{\text{IN}} = 450 \text{ MHz}$		85		
IMD3	2F1-F2, 2F2-F1, $A_{\text{in}} = -7 \text{ dBFS}$	$F_{\text{IN}} = 169 \text{ and } 171 \text{ MHz}$		93		dBFS

6.7 Electrical Characteristics: 500 MSPS Output

Typical values at $T_A = 25^\circ\text{C}$, full temperature range is $T_{\text{MIN}} = -40^\circ\text{C}$ to $T_{\text{MAX}} = 85^\circ\text{C}$, ADC sampling rate = 500 MSPS, 50% clock duty cycle, AVDD33 = 3.3 V; AVDD18 = 1.9 V; AVDDC, DVDD, IOVDD, PLLVDD = 1.8 V, -1-dBFS differential input, unless otherwise noted.

PARAMETER		TEST CONDITIONS	MIN	TYP	MAX	UNIT
SNR	Signal-to-Noise Ratio	Bypass Digital Mode (14 bit)	$f_{\text{IN}} = 10 \text{ MHz}$		65.3	dBFS
			$f_{\text{IN}} = 100 \text{ MHz}$		65.2	
			$f_{\text{IN}} = 170 \text{ MHz}$	61	64.9	
			$f_{\text{IN}} = 370 \text{ MHz}$		64.7	
			$f_{\text{IN}} = 450 \text{ MHz}$		64.6	
HD2	Second Harmonic Distortion		$f_{\text{IN}} = 10 \text{ MHz}$		85	dBc
			$f_{\text{IN}} = 100 \text{ MHz}$		85	
			$f_{\text{IN}} = 170 \text{ MHz}$	70	85	
			$f_{\text{IN}} = 370 \text{ MHz}$		75	
			$f_{\text{IN}} = 450 \text{ MHz}$		75	
HD3	Third Harmonic Distortion		$f_{\text{IN}} = 10 \text{ MHz}$		85	dBc
			$f_{\text{IN}} = 100 \text{ MHz}$		85	
			$f_{\text{IN}} = 170 \text{ MHz}$	70	85	
			$f_{\text{IN}} = 370 \text{ MHz}$		85	
			$f_{\text{IN}} = 450 \text{ MHz}$		85	
SFDR (Non-HD2, Non-HD3)	Spur Free Dynamic Range (excluding HD2 and HD3)		$f_{\text{IN}} = 10 \text{ MHz}$		85	dBFS
			$f_{\text{IN}} = 100 \text{ MHz}$		85	
			$f_{\text{IN}} = 170 \text{ MHz}$	70	85	
			$f_{\text{IN}} = 370 \text{ MHz}$		83	
			$f_{\text{IN}} = 450 \text{ MHz}$		83	
IMD3	2F1-F2, 2F2-F1, $A_{\text{in}} = -7 \text{ dBFS}$	$f_{\text{IN}} = 169 \text{ and } 171 \text{ MHz}$		87		dBFS

6.8 Electrical Characteristics: Sample Clock Timing Characteristics

Typical values at $T_A = 25^\circ\text{C}$, full temperature range is $T_{\text{MIN}} = -40^\circ\text{C}$ to $T_{\text{MAX}} = 85^\circ\text{C}$, ADC sampling rate = 500 MSPS, 50% clock duty cycle, AVDD33 = 3.3 V; AVDD18 = 1.9 V; AVDDC, DVDD, IOVDD, PLLVDD = 1.8 V, -1 dBFS differential input, unless otherwise noted.

PARAMETER		MIN	TYP	MAX	UNIT
	Aperture jitter, RMS		98		fs rms
	Data latency		38		Sample clock cycles
	Fast over-range (OVR) latency		6		
t_{PDI}	Clock aperture delay		1.1		ns

6.9 Electrical Characteristics: Digital Outputs

The DC specifications refer to the condition where the digital outputs are not switching, but are permanently at a valid logic level 0 or 1. AVDD33 = 3.3 V; AVDD18 = 1.9 V; AVDDC, DVDD, IOVDD, PLLVDD = 1.8 V.

PARAMETER		MIN	TYP	MAX	UNIT
DIGITAL OUTPUTS: JESD204B INTERFACE (DA[0,1], DB[0,1], DC[0,1], DD[0,1])					
Output differential voltage, VOD		450	577	750	mV
Transmitter short circuit current	Transmitter terminals shorted to any voltage between –0.25 and 1.45 V		45		mA
Single ended output impedance			50		Ω
Output capacitance	Output capacitance inside the device, from either output to ground		2		pF
Unit interval, UI	5.0 Gbps		200		ps
Rise and fall times			110		ps
Output jitter			57		ps
Serial output data rate			5.0		Gbps

6.10 Timing Requirements

		MIN	TYP	MAX	UNIT
DIGITAL INPUTS: SRESETb, SCLK, SDENb, SDATA, ENABLE, OVRA, OVRC, SYSREFCDP, SYSREFCDM					
High-level input voltage	All digital inputs support 1.8-V and 3.3-V logic levels	1.2			V
Low-level input voltage				0.4	V
High-level input current			50		μ A
Low-level input current			–50		μ A
Input capacitance			4		pF
DIGITAL OUTPUTS: SDOUT, OVRA, OVRB, OVRC, OVRD					
High-level output voltage	$I_{Load} = -100 \mu A$	DVDD – 0.2	DVDD		V
Low-level output voltage				0.2	V
DIGITAL INPUTS: SYNCbABP/M, SYNCbCDP/M, SYSREFABP/M, SYSREFCDP/M					
Input voltage VID		250	350	450	mV
Input common mode voltage VCM		0.4	0.9	1.4	V
$t_{S_SYSREFxx}$	Referenced to rising edge of input clock		100		ps
$t_{H_SYSREFxx}$	Referenced to rising edge of input clock		100		ps

6.11 Reset Timing

PARAMETER	TEST CONDITIONS	MIN	TYP	MAX	UNIT
t_1 Power-on delay	Delay from power up to active-low RESET pulse	3			ms
t_2 Reset pulse duration	Active-low RESET pulse duration	20			ns
t_3 Register write delay	Delay from RESET disable to SDENb active	100			ns

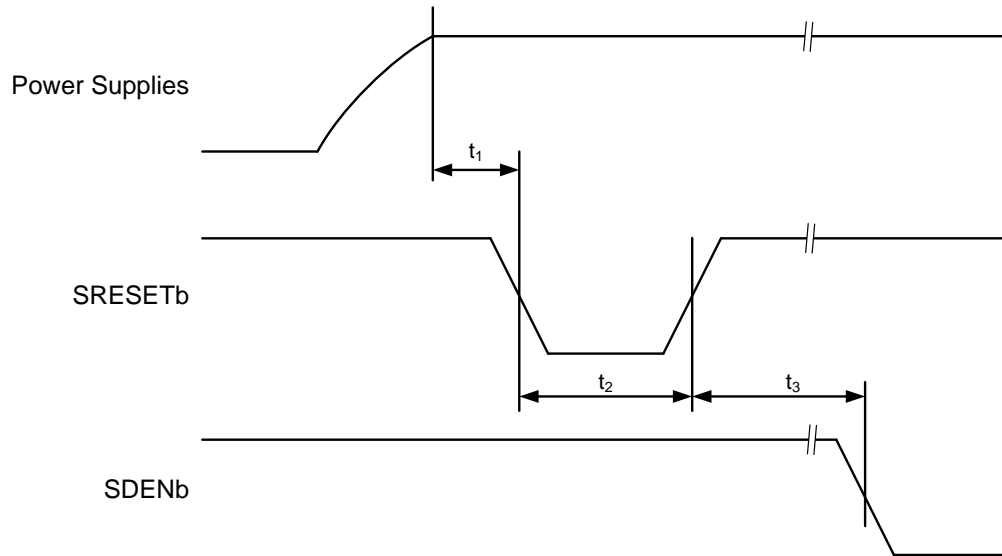
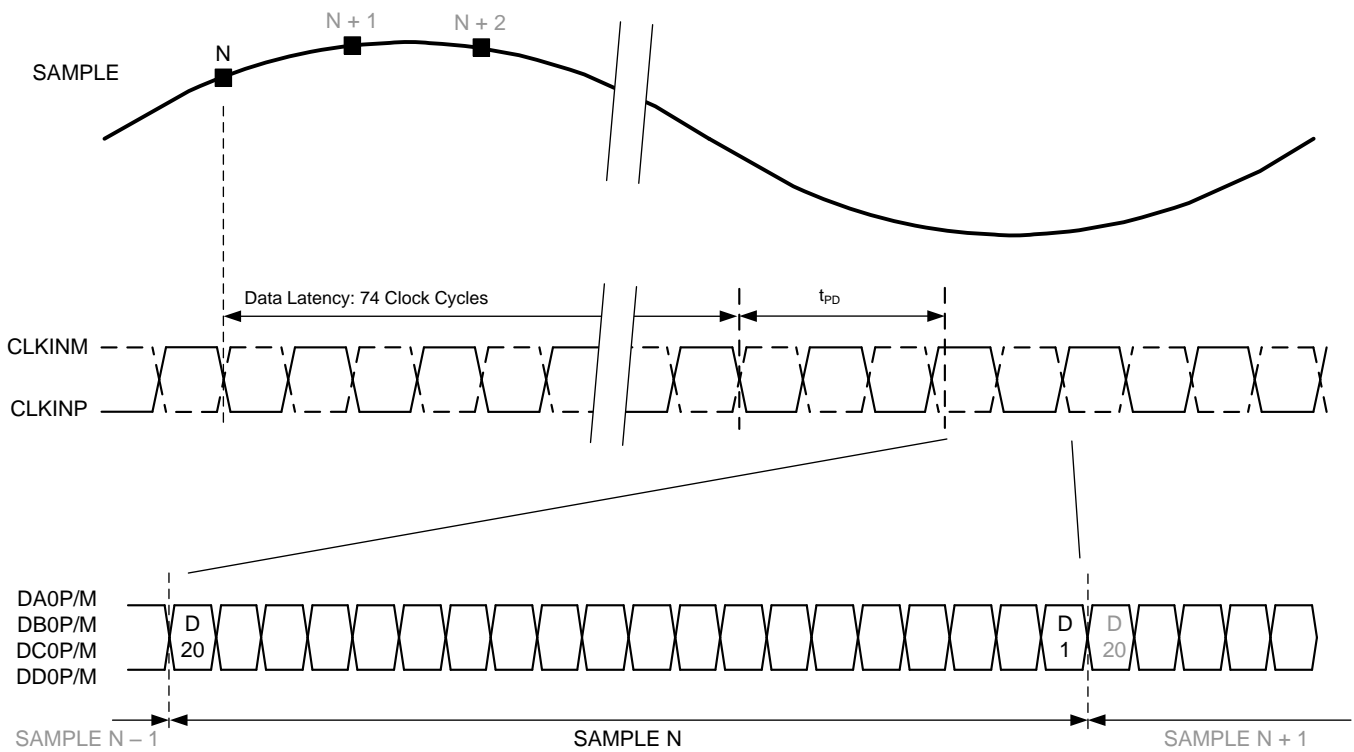
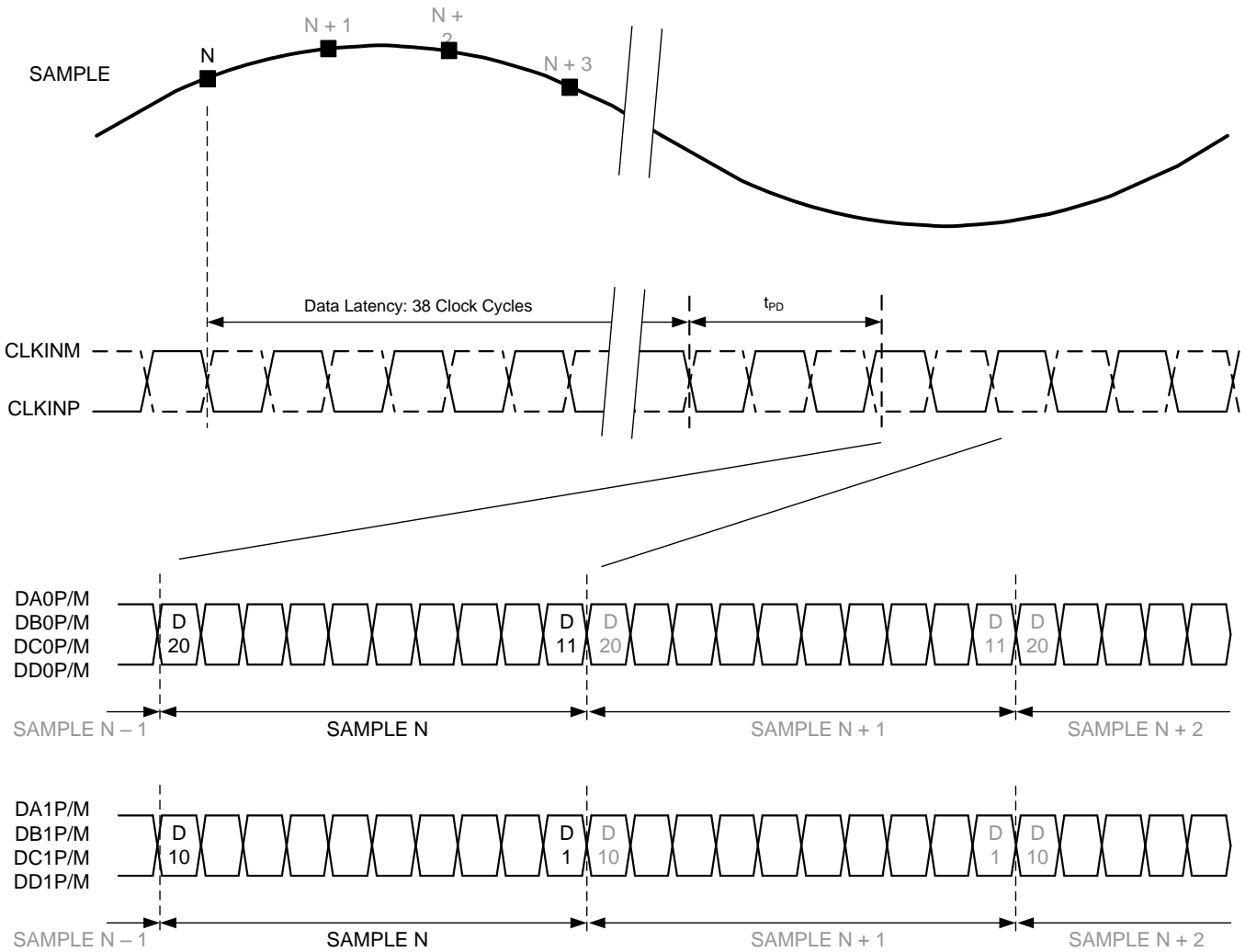

Figure 1. Reset Timing Diagram



A. t_{PD} is the propagation delay from sample clock input edge to serial data output transition

Figure 2. Timing Diagram: 250 MSPS Output Data Rate



B. t_{PD} is the propagation delay from sample clock input edge to serial data output transition

Figure 3. Timing Diagram: 500 MSPS Output Data Rate

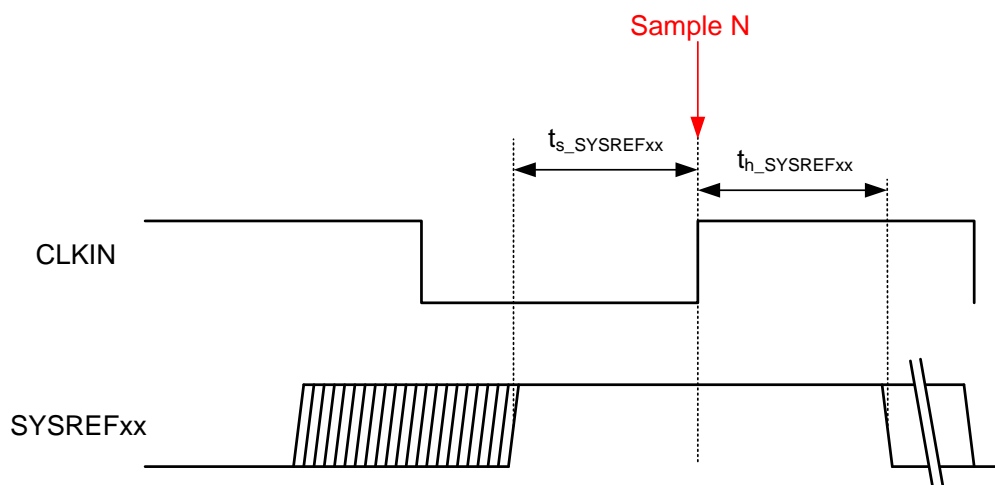
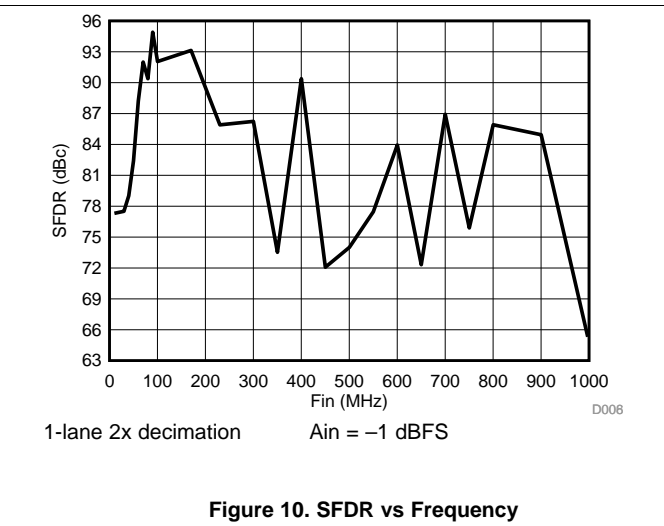
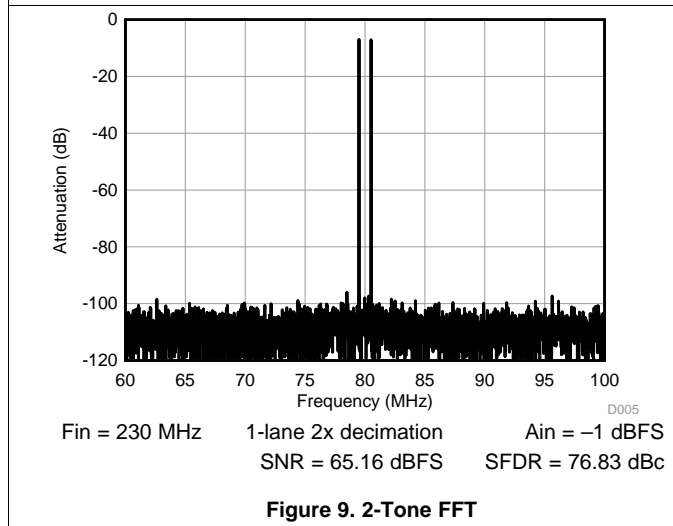
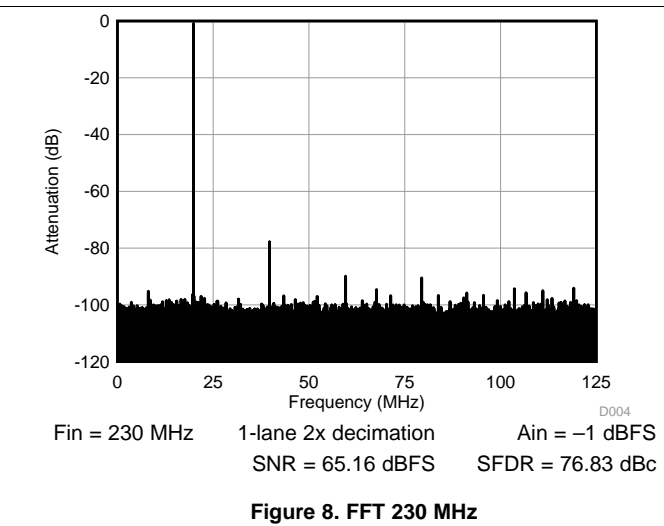
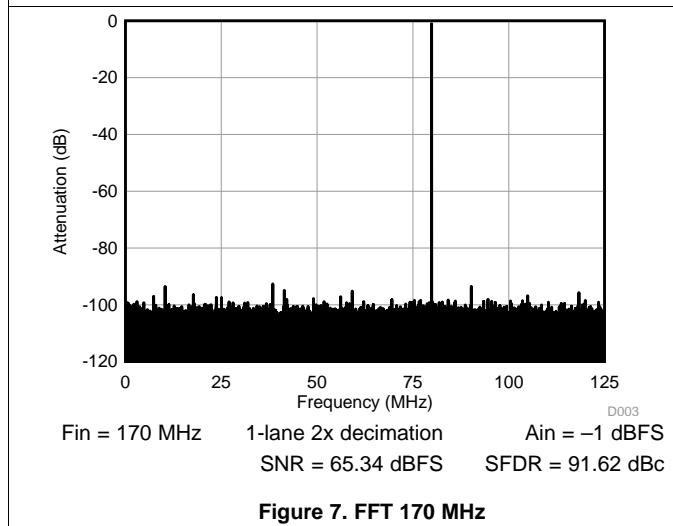
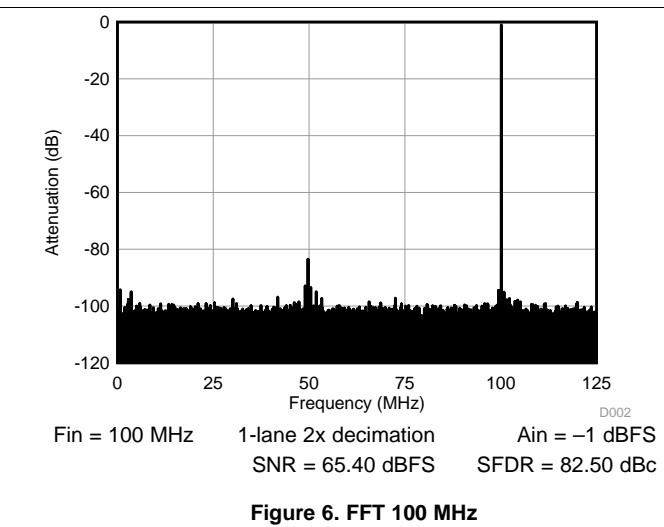
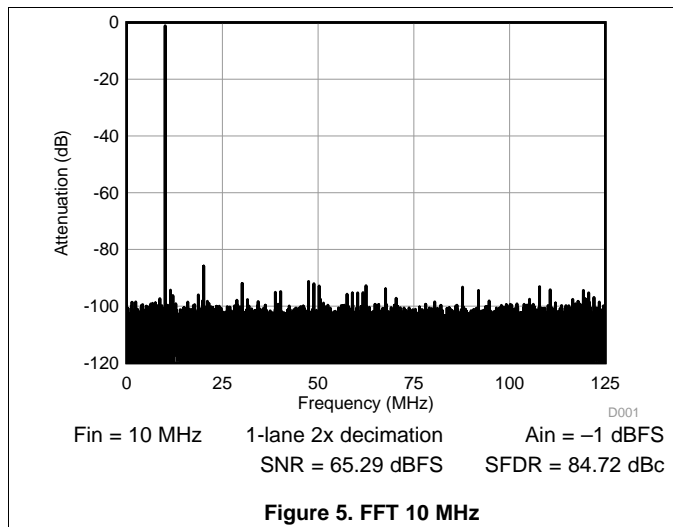

Figure 4. Timing Using SYSREF (Subclass 1)

6.12 Typical Characteristics

Typical values at $T_A = 25^\circ\text{C}$, full temperature range is $T_{\text{MIN}} = -40^\circ\text{C}$ to $T_{\text{MAX}} = 85^\circ\text{C}$, Device clock frequency = 500 MHz, Output sample data rate = 5Gbps, 50% Device clock duty cycle, AVDD33 = 3.3 V, AVDD18 = 1.9 V, AVDDC = 1.8 V, IOVDD = 1.8 V, PLLVDD = 1.8 V, DVDD = 1.8 V, -1 dBFS differential input, unless otherwise noted, FFT sample size = 32768.



Typical Characteristics (continued)

Typical values at $T_A = 25^\circ\text{C}$, full temperature range is $T_{\text{MIN}} = -40^\circ\text{C}$ to $T_{\text{MAX}} = 85^\circ\text{C}$, Device clock frequency = 500 MHz, Output sample data rate = 5Gbps, 50% Device clock duty cycle, AVDD33 = 3.3 V, AVDD18 = 1.9 V, AVDDC = 1.8 V, IOVDD = 1.8 V, PLLVDD = 1.8 V, DVDD = 1.8 V, -1 dBFS differential input, unless otherwise noted, FFT sample size = 32768.

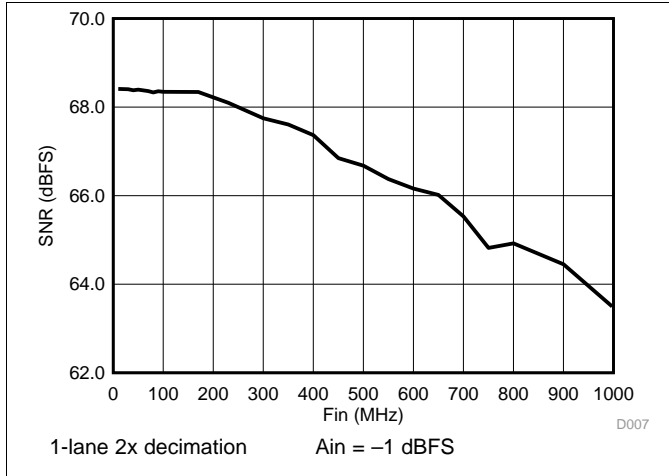

Figure 11. SNR vs. Frequency

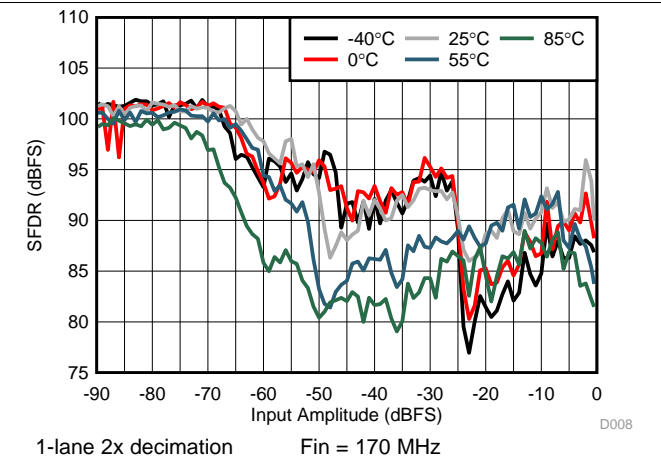

Figure 12. SFDR vs. Amplitude

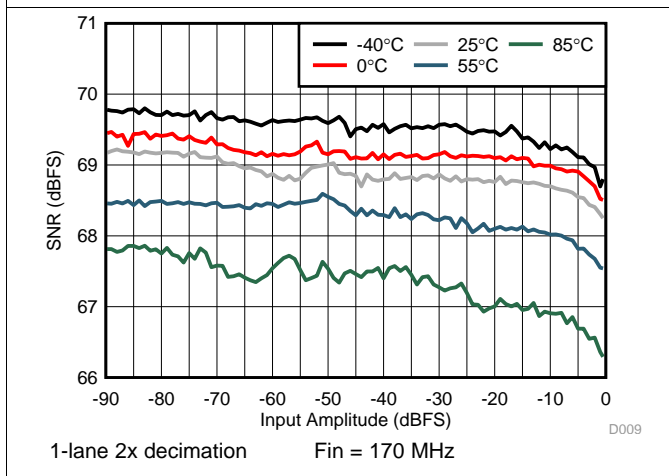

Figure 13. SNR vs. Amplitude

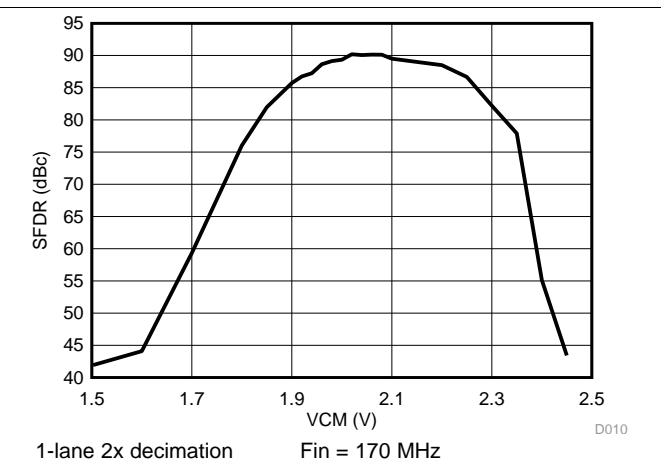

Figure 14. SFDR vs. VCM

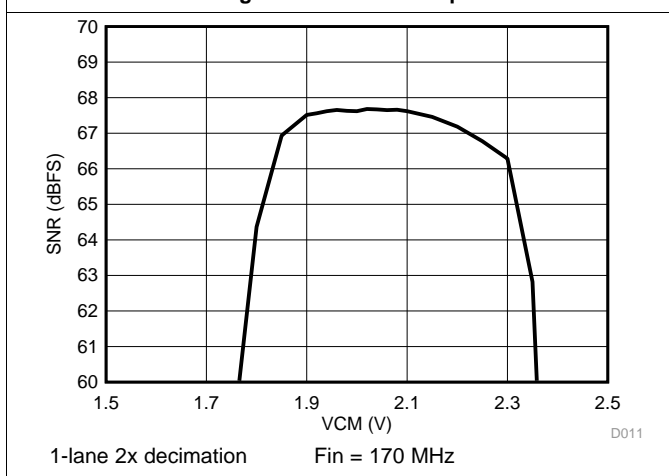

Figure 15. SNR vs VCM

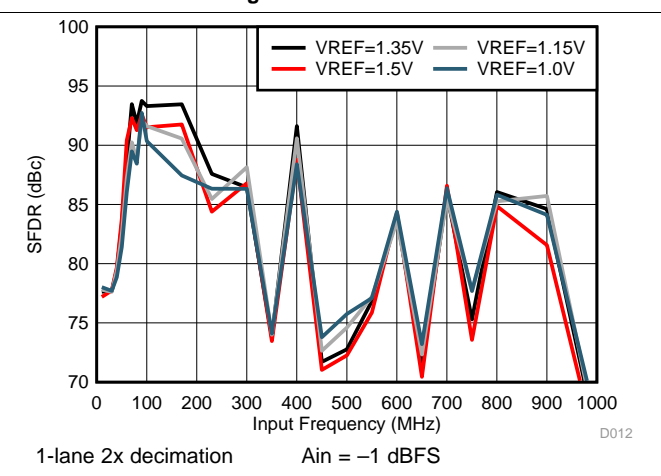
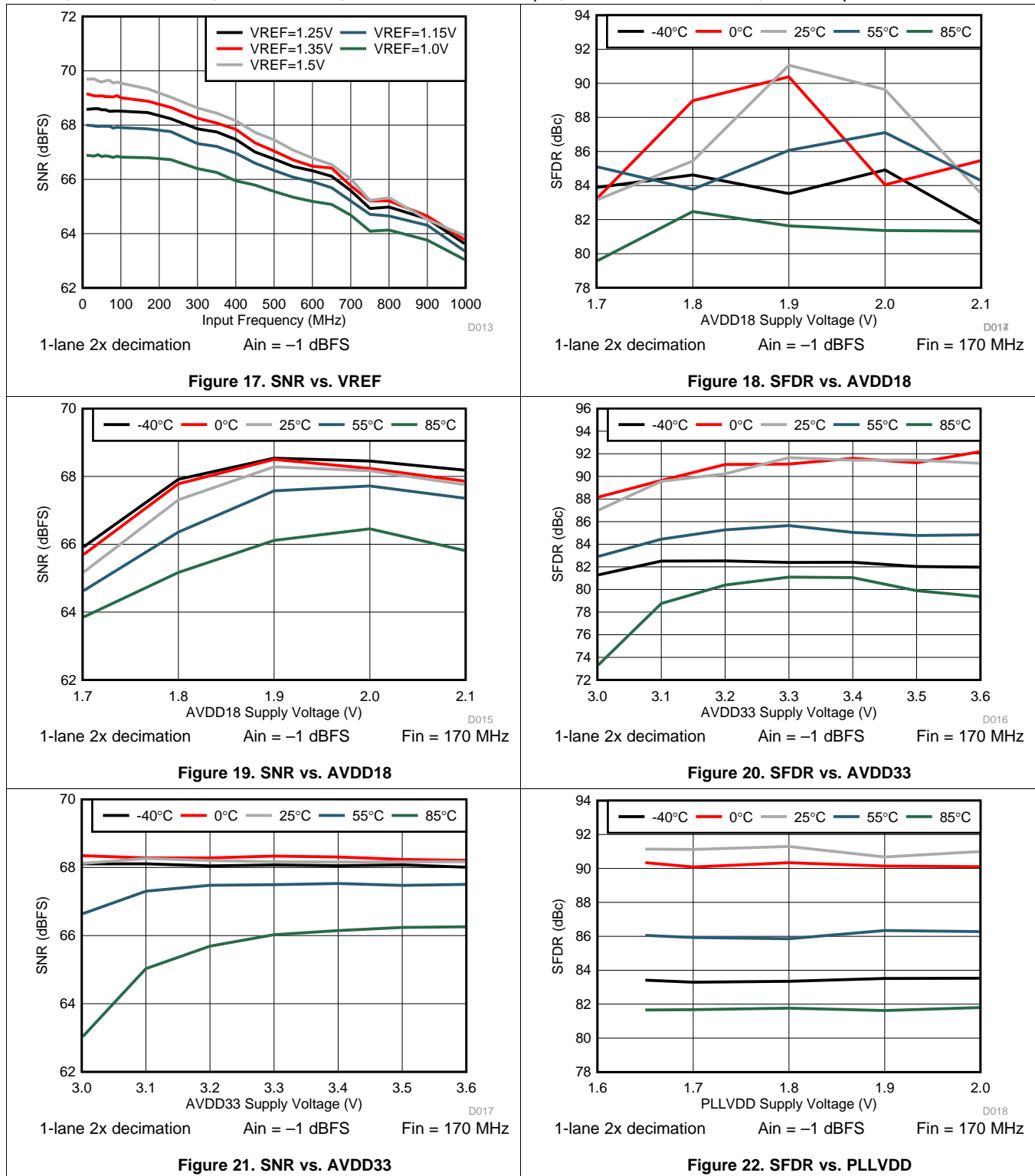

Figure 16. SFDR vs. VREF

Typical Characteristics (continued)

Typical values at $T_A = 25^\circ\text{C}$, full temperature range is $T_{\text{MIN}} = -40^\circ\text{C}$ to $T_{\text{MAX}} = 85^\circ\text{C}$, Device clock frequency = 500 MHz, Output sample data rate = 5Gbps, 50% Device clock duty cycle, AVDD33 = 3.3 V, AVDD18 = 1.9 V, AVDDC = 1.8 V, IOVDD = 1.8 V, PLLVDD = 1.8 V, DVDD = 1.8 V, -1 dBFS differential input, unless otherwise noted, FFT sample size = 32768.



Typical Characteristics (continued)

Typical values at $T_A = 25^\circ\text{C}$, full temperature range is $T_{\text{MIN}} = -40^\circ\text{C}$ to $T_{\text{MAX}} = 85^\circ\text{C}$, Device clock frequency = 500 MHz, Output sample data rate = 5Gbps, 50% Device clock duty cycle, AVDD33 = 3.3 V, AVDD18 = 1.9 V, AVDDC = 1.8 V, IOVDD = 1.8 V, PLLVDD = 1.8 V, DVDD = 1.8 V, -1 dBFS differential input, unless otherwise noted, FFT sample size = 32768.

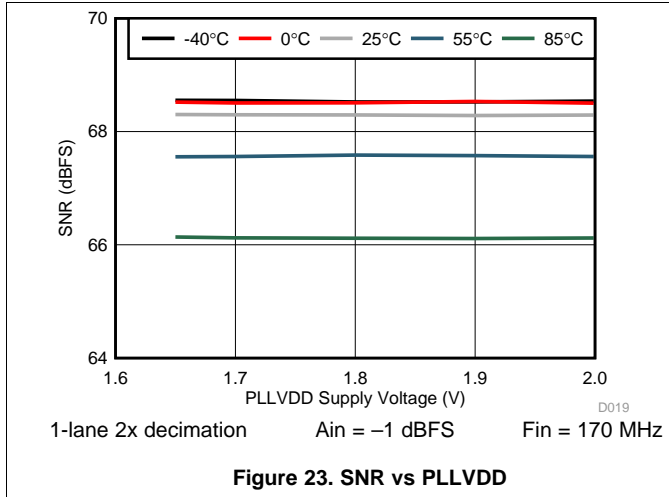

Figure 23. SNR vs PLLVDD

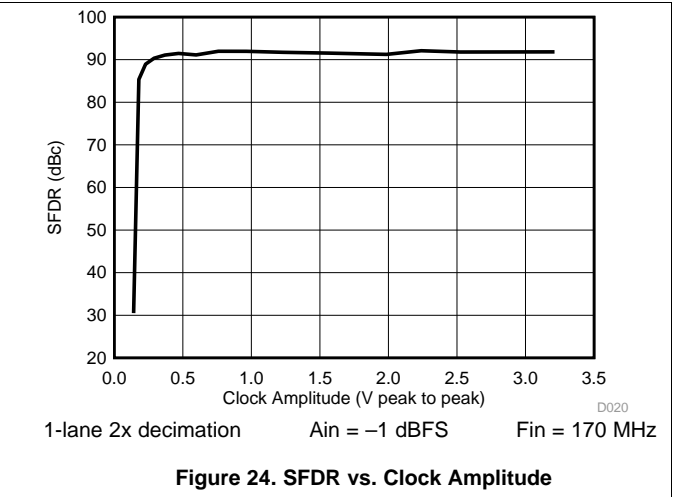

Figure 24. SFDR vs. Clock Amplitude

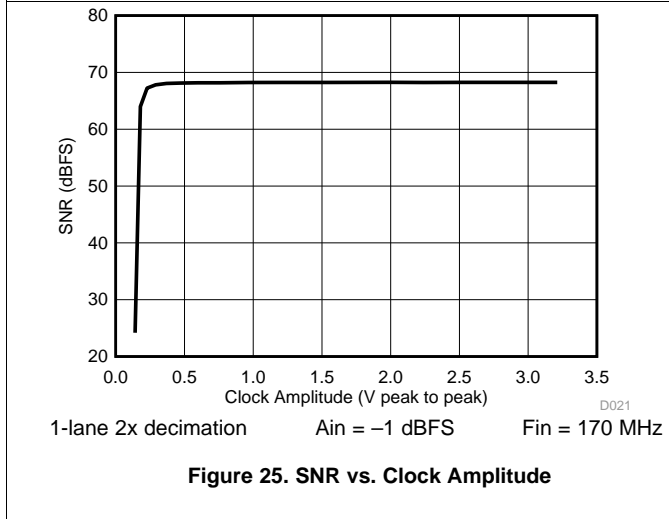

Figure 25. SNR vs. Clock Amplitude

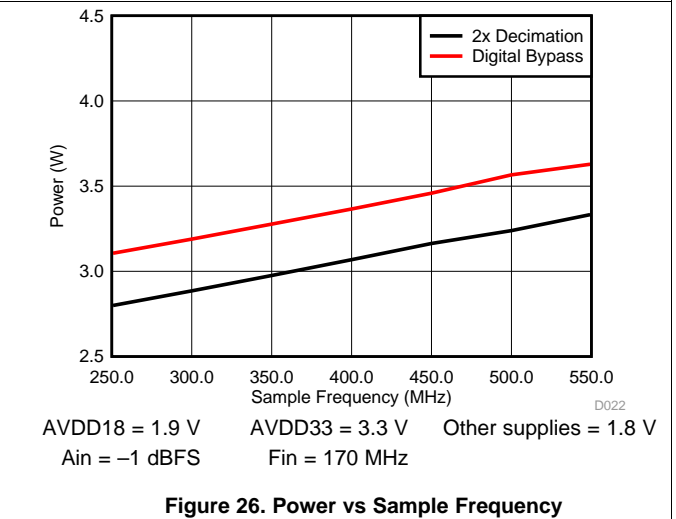

Figure 26. Power vs Sample Frequency

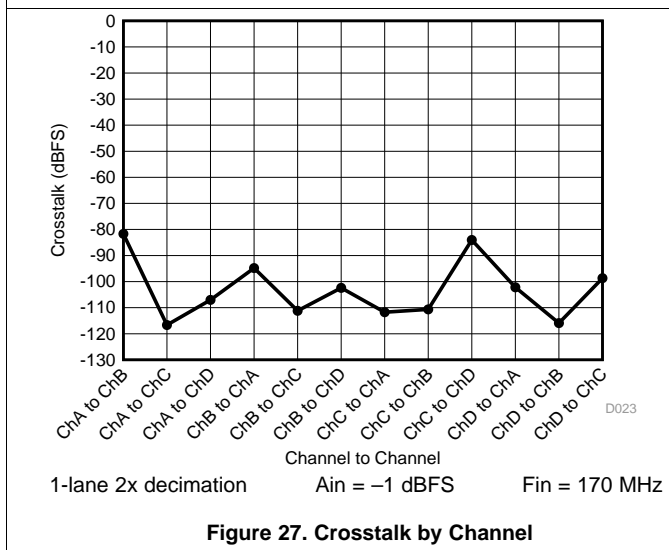

Figure 27. Crosstalk by Channel

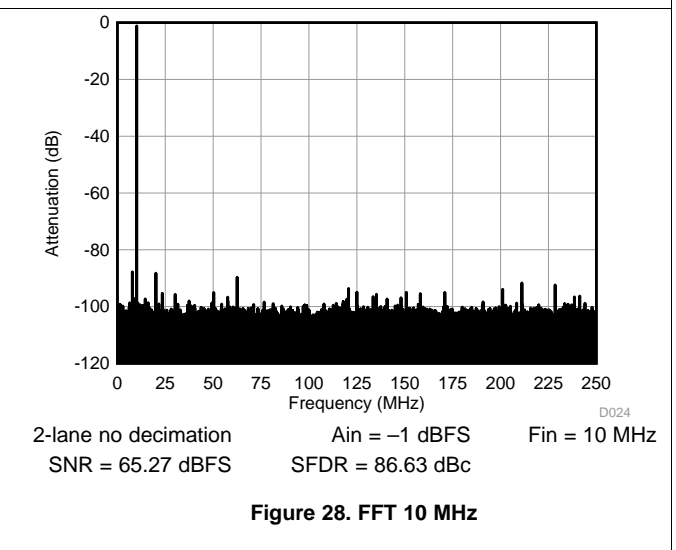
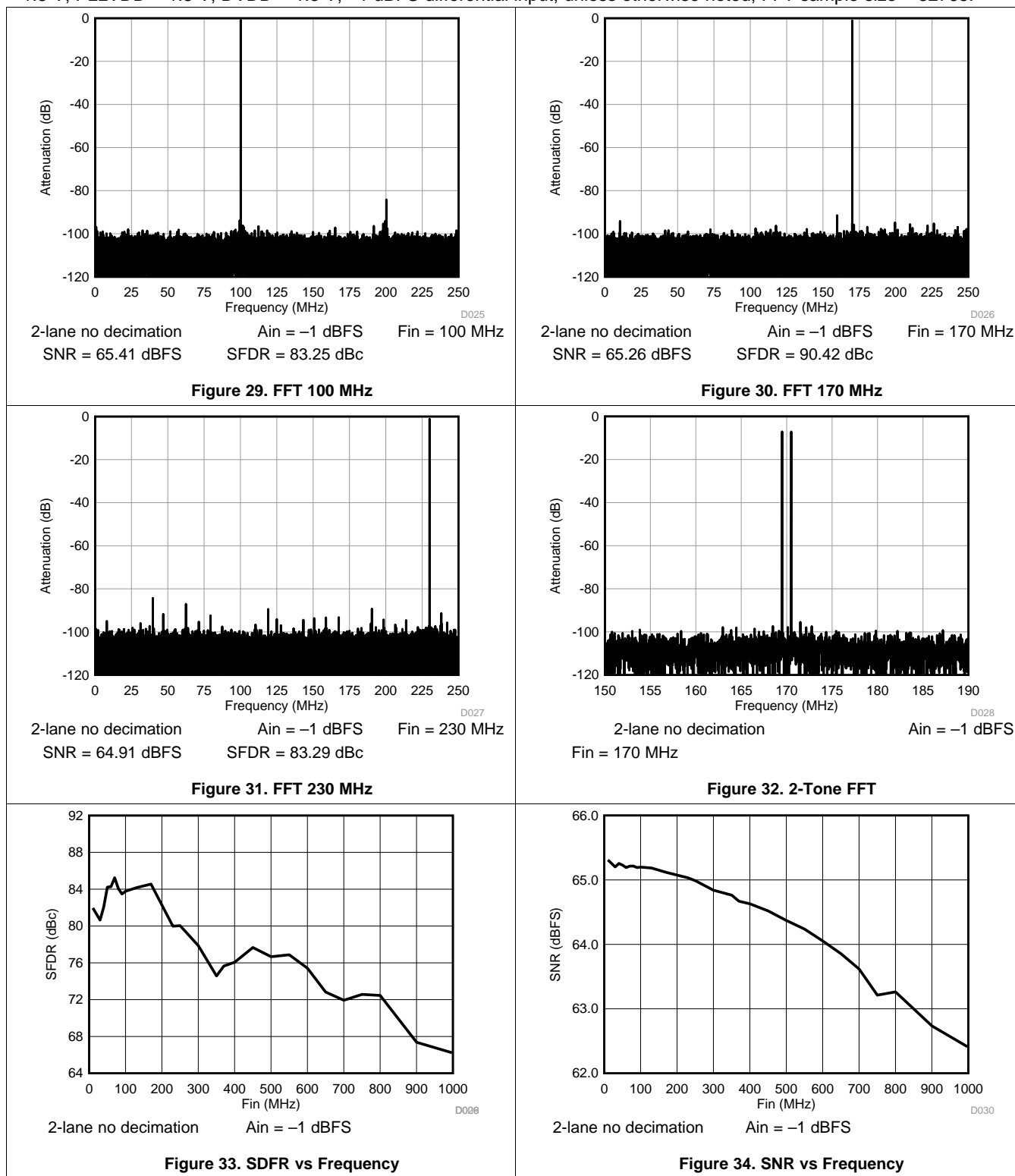

Figure 28. FFT 10 MHz

Typical Characteristics (continued)

Typical values at $T_A = 25^\circ\text{C}$, full temperature range is $T_{\text{MIN}} = -40^\circ\text{C}$ to $T_{\text{MAX}} = 85^\circ\text{C}$, Device clock frequency = 500 MHz, Output sample data rate = 5Gbps, 50% Device clock duty cycle, AVDD33 = 3.3 V, AVDD18 = 1.9 V, AVDDC = 1.8 V, IOVDD = 1.8 V, PLLVDD = 1.8 V, DVDD = 1.8 V, -1 dBFS differential input, unless otherwise noted, FFT sample size = 32768.



Typical Characteristics (continued)

Typical values at $T_A = 25^\circ\text{C}$, full temperature range is $T_{\text{MIN}} = -40^\circ\text{C}$ to $T_{\text{MAX}} = 85^\circ\text{C}$, Device clock frequency = 500 MHz, Output sample data rate = 5Gbps, 50% Device clock duty cycle, AVDD33 = 3.3 V, AVDD18 = 1.9 V, AVDDC = 1.8 V, IOVDD = 1.8 V, PLLVDD = 1.8 V, DVDD = 1.8 V, -1 dBFS differential input, unless otherwise noted, FFT sample size = 32768.

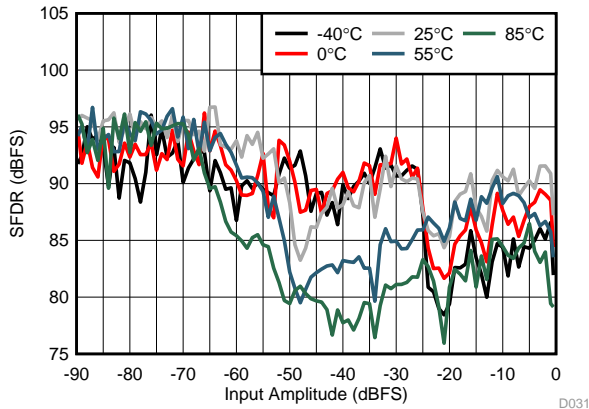

Figure 35. SFDR vs Amplitude

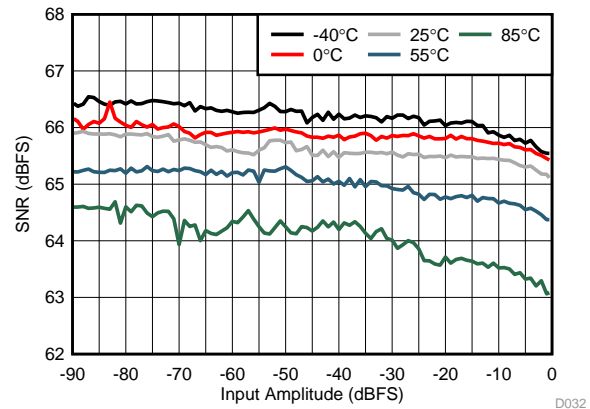

Figure 36. SNR vs Amplitude

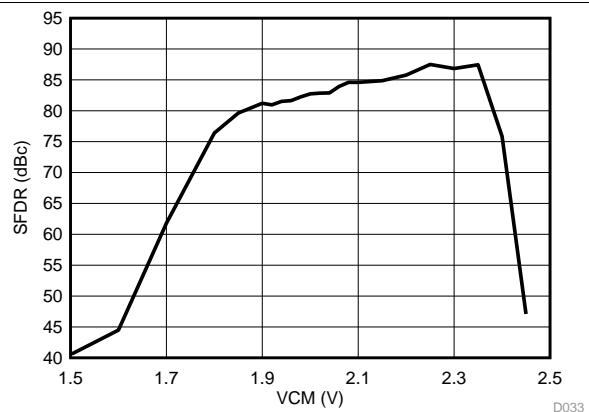

Figure 37. SFDR vs VCM

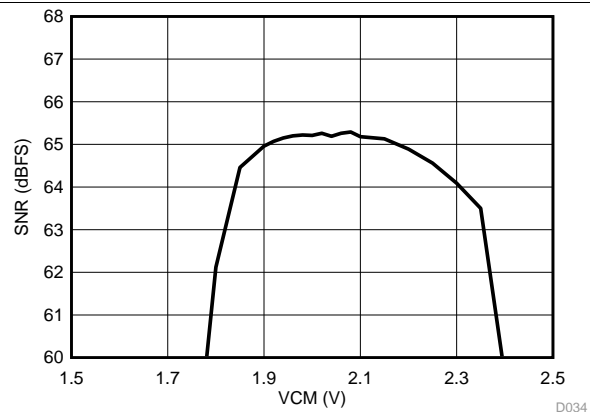

Figure 38. SNR vs VCM

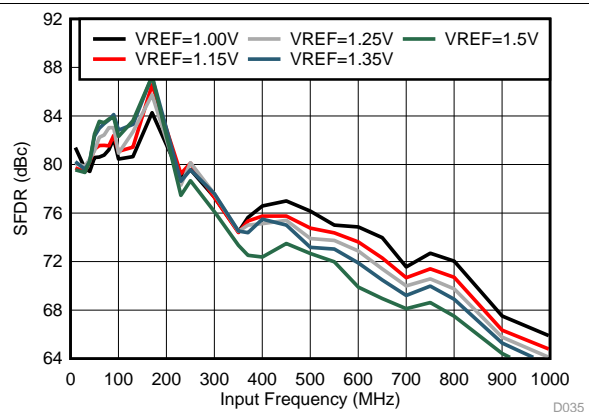

Figure 39. SFDR vs Input Frequency

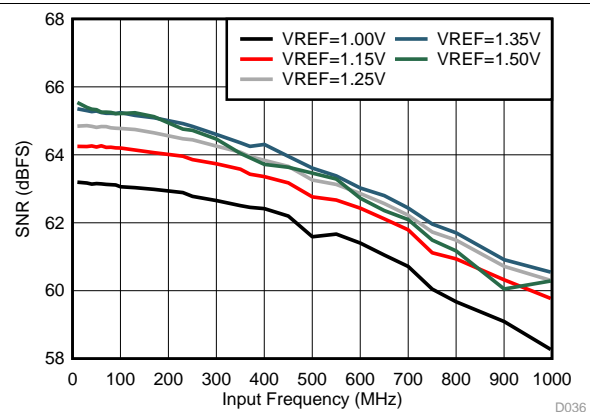

Figure 40. SNR vs Input Frequency

Typical Characteristics (continued)

Typical values at $T_A = 25^\circ\text{C}$, full temperature range is $T_{\text{MIN}} = -40^\circ\text{C}$ to $T_{\text{MAX}} = 85^\circ\text{C}$, Device clock frequency = 500 MHz, Output sample data rate = 5Gbps, 50% Device clock duty cycle, AVDD33 = 3.3 V, AVDD18 = 1.9 V, AVDDC = 1.8 V, IOVDD = 1.8 V, PLLVDD = 1.8 V, DVDD = 1.8 V, -1 dBFS differential input, unless otherwise noted, FFT sample size = 32768.

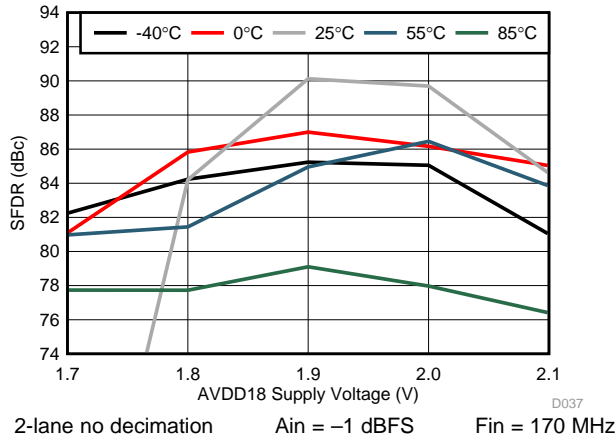

Figure 41. SFDR vs AVDD18 Supply Voltage

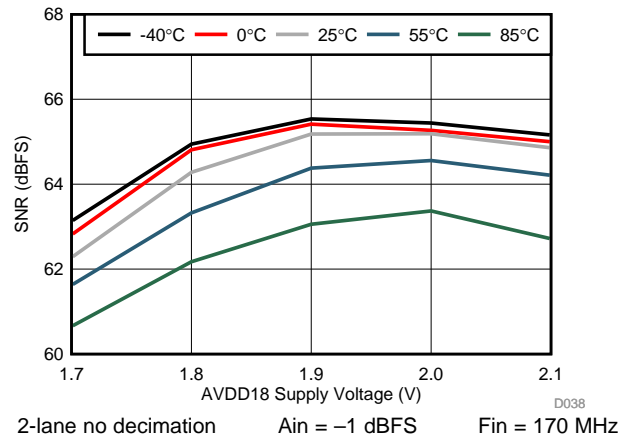

Figure 42. SNR vs AVDD18 Supply Voltage

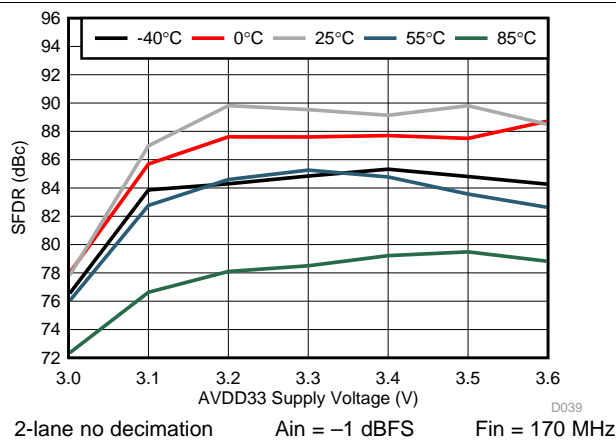

Figure 43. SFDR vs AVDD33 Supply Voltage

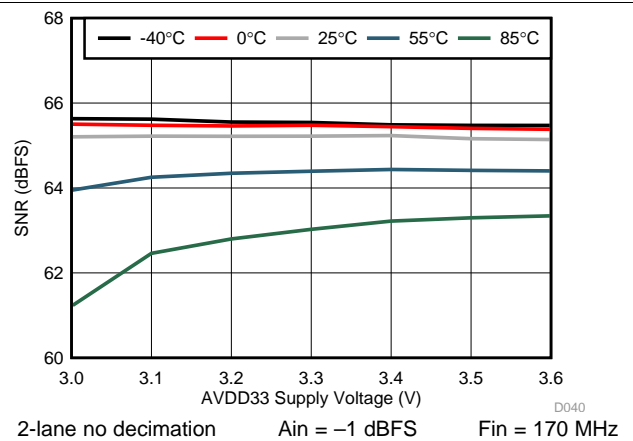

Figure 44. SNR vs AVDD33 Supply Voltage

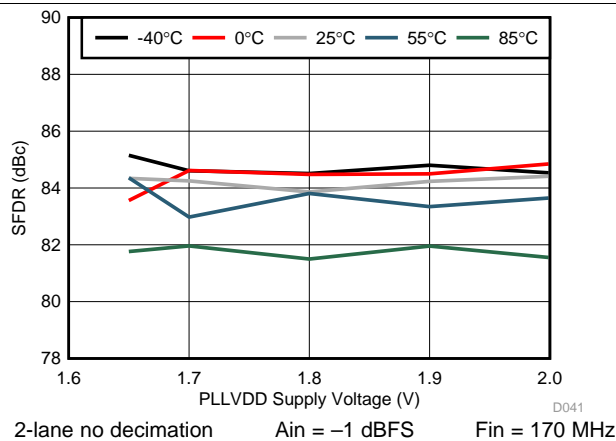

Figure 45. SFDR vs PLLVDD Supply Voltage

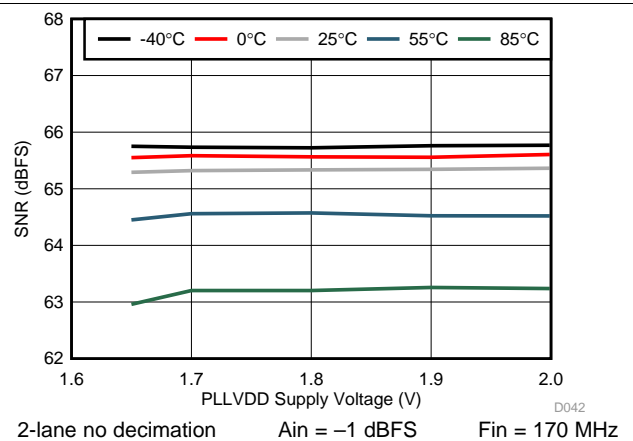

Figure 46. SNR vs PLLVDD Supply Voltage

Typical Characteristics (continued)

Typical values at $T_A = 25^\circ\text{C}$, full temperature range is $T_{\text{MIN}} = -40^\circ\text{C}$ to $T_{\text{MAX}} = 85^\circ\text{C}$, Device clock frequency = 500 MHz, Output sample data rate = 5Gbps, 50% Device clock duty cycle, AVDD33 = 3.3 V, AVDD18 = 1.9 V, AVDDC = 1.8 V, IOVDD = 1.8 V, PLLVDD = 1.8 V, DVDD = 1.8 V, -1 dBFS differential input, unless otherwise noted, FFT sample size = 32768.

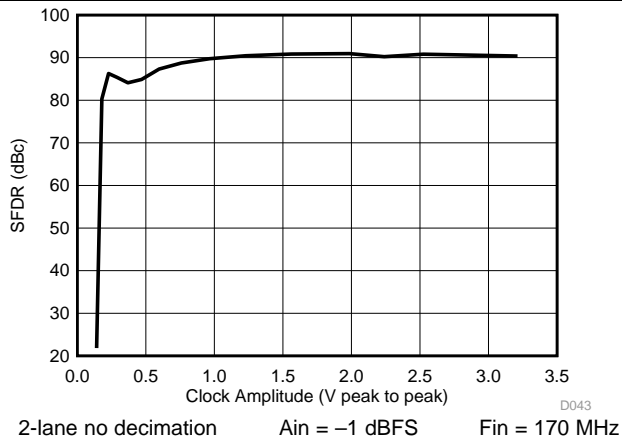

Figure 47. SFDR vs Clock Amplitude

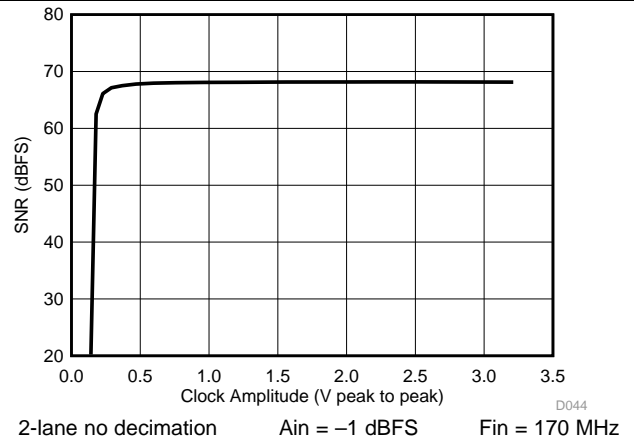

Figure 48. SNR vs Clock Amplitude

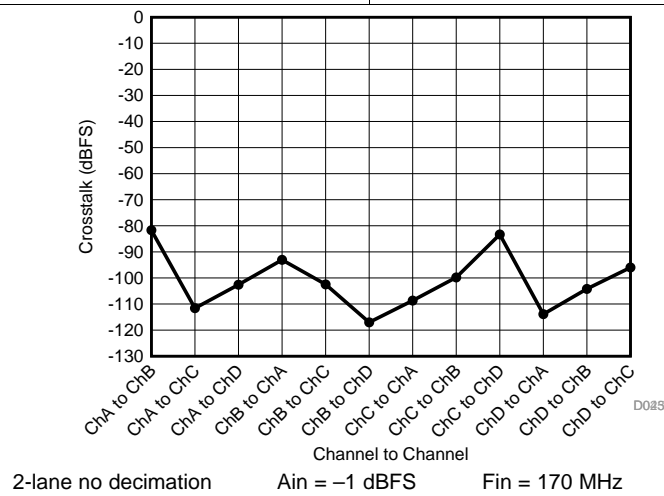
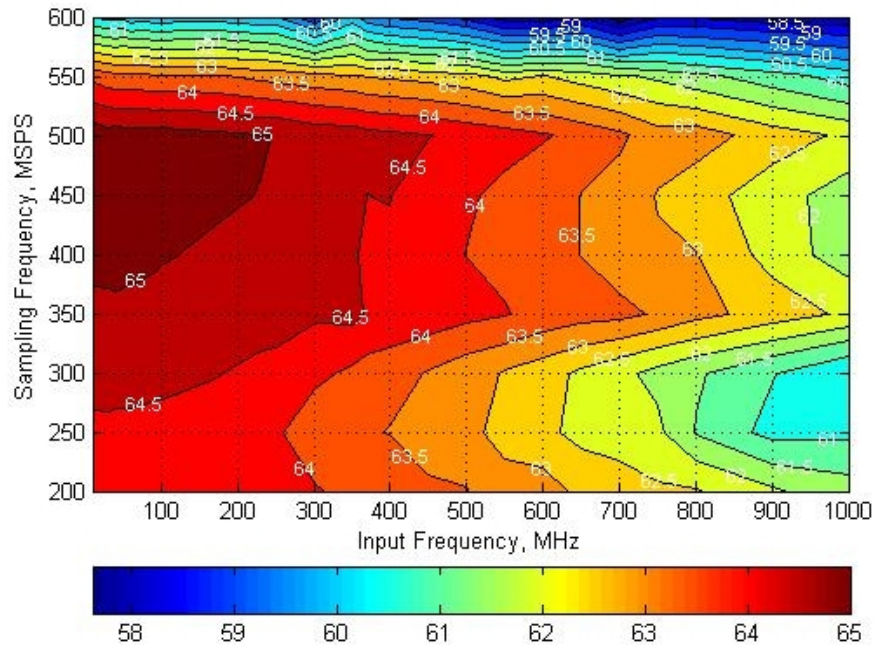

Figure 49. Crosstalk by Channel

Typical Characteristics (continued)

Typical values at $T_A = 25^\circ\text{C}$, full temperature range is $T_{\text{MIN}} = -40^\circ\text{C}$ to $T_{\text{MAX}} = 85^\circ\text{C}$, Device clock frequency = 500 MHz, Output sample data rate = 5Gbps, 50% Device clock duty cycle, AVDD33 = 3.3 V, AVDD18 = 1.9 V, AVDDC = 1.8 V, IOVDD = 1.8 V, PLLVDD = 1.8 V, DVDD = 1.8 V, -1 dBFS differential input, unless otherwise noted, FFT sample size = 32768.



2lane no decimation

Figure 50. SNR Contour Plot

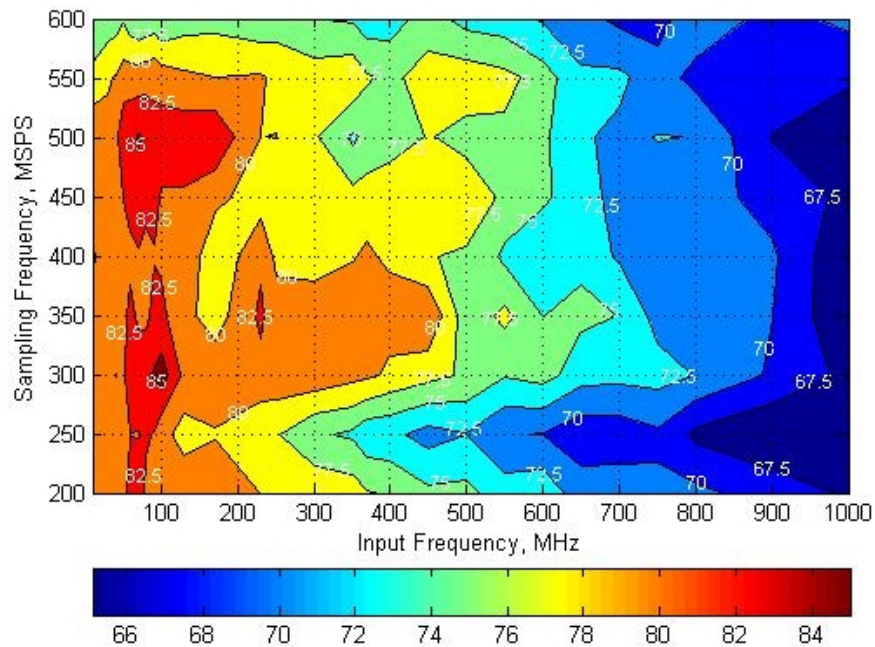

2lane no decimation

Figure 51. SFDR Contour Plot

Typical Characteristics (continued)

Typical values at $T_A = 25^\circ\text{C}$, full temperature range is $T_{\text{MIN}} = -40^\circ\text{C}$ to $T_{\text{MAX}} = 85^\circ\text{C}$, Device clock frequency = 500 MHz, Output sample data rate = 5Gbps, 50% Device clock duty cycle, AVDD33 = 3.3 V, AVDD18 = 1.9 V, AVDDC = 1.8 V, IOVDD = 1.8 V, PLLVDD = 1.8 V, DVDD = 1.8 V, -1 dBFS differential input, unless otherwise noted, FFT sample size = 32768.

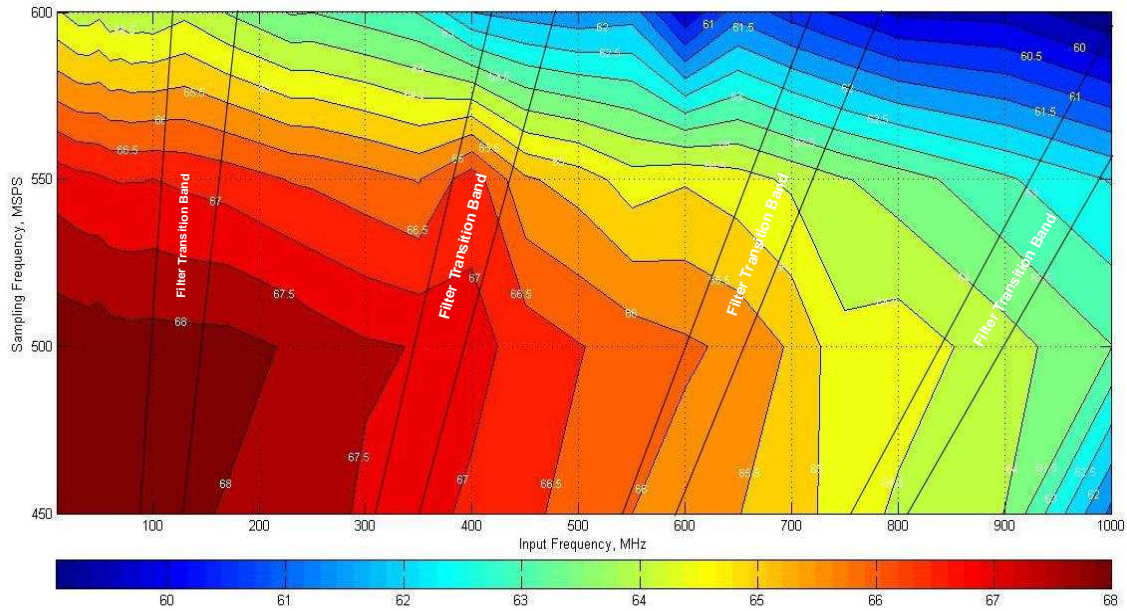

1lane 2x decimation

Figure 52. SNR Contour Plot

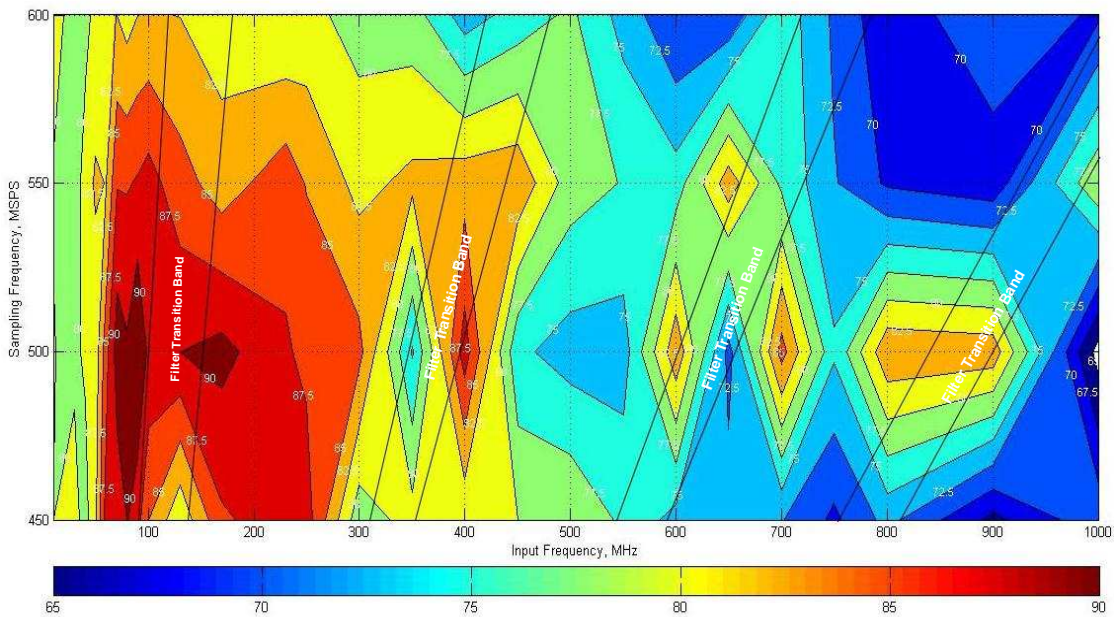

1lane 2x decimation

Figure 53. SFDR Contour Plot

7 Detailed Description

7.1 Overview

The ADS54J54 is a low power, wide bandwidth 14-bit 500 MSPS quad channel ADC. It supports the JESD204B serial interface with data rates up to 5.0 Gbps supporting 1 or 2 lanes per channel. The buffered analog input provides uniform input impedance across a wide frequency range while minimizing sample-and-hold glitch energy. A sampling clock divider allows more flexibility for system clock architecture design. The ADS54J54 provides excellent SFDR over a large input frequency range with low power consumption.

7.2 Functional Block Diagram

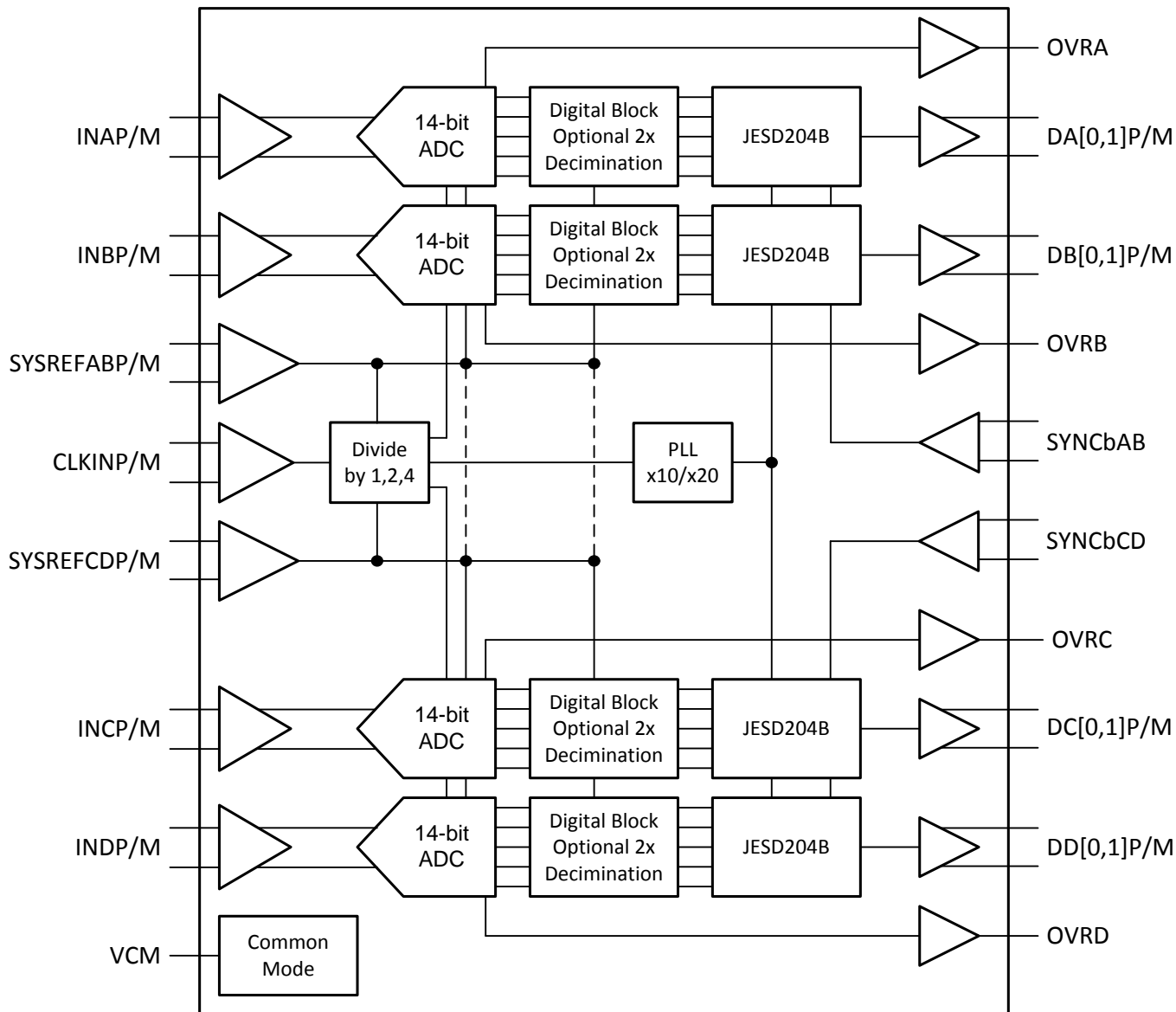

7.3 Feature Description

7.3.1 Decimation by 2 (250 MSPS Output)

Each channel has a digital filter in the data path as shown in Figure 54. The filter can be programmed as a low-pass or high-pass filter and the normalized frequency response of both filters is shown in Figure 55.

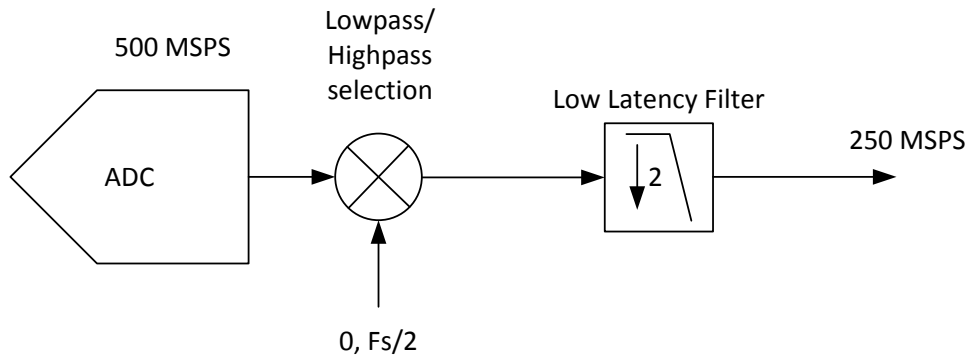

Figure 54. 2x Decimation Filter

The decimation filter response has a 0.1-dB pass band ripple with approximately 41% pass-band bandwidth. The stop-band attenuation is approximately 40 dB.

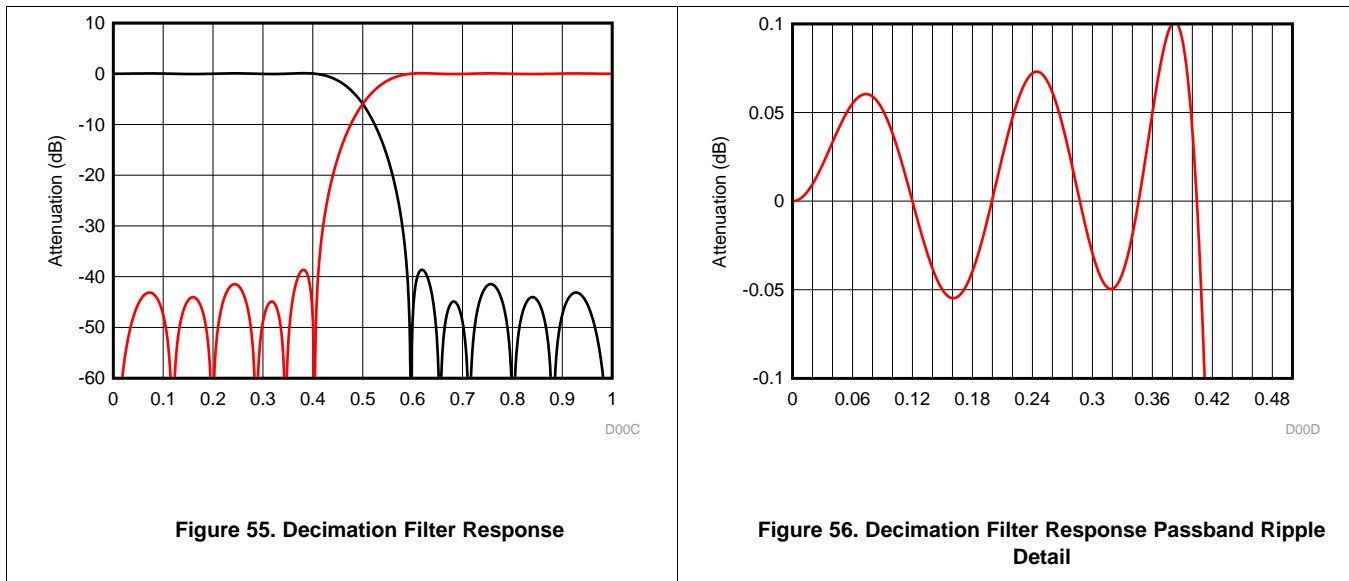

Figure 55. Decimation Filter Response

Figure 56. Decimation Filter Response Passband Ripple Detail

7.3.2 Over-Range Indication

The ADS54J54 provides a fast over-range indication on the OVRA, OVRB, OVRC, and OVRD pins. The fast OVR is triggered if the input voltage exceeds the programmable over-range threshold and is output after just 6 clock cycles, enabling a quicker reaction to an over-range event. The OVR threshold can be configured using SPI register writes.

The input voltage level at which the overload is detected is referred to as the threshold and is programmable using the over-range threshold bits.

The threshold at which fast OVR is triggered is (full-scale × [the decimal value of the FAST OVR THRESH bits] / 8). After reset, the default value of the over-range threshold is set to 7 (decimal), which corresponds to a threshold of 1.12 dB below full scale (20 × log(7/8)).

Table 1. Fast Over Range Threshold Settings

OVR Setting (decimal)	OVR Threshold (dBFS)
1	-18.1
2	-12.0
3	-8.5
4	-6.0
5	-4.1
6	-2.5
7 (default)	-1.1

Because the fast over-range indicator is single-ended LVCMOS logic, the ADS54J54 device can be configured through the SPI register write to keep the over-range indicator asserted high for an extra one, two, or four clock cycles. This longer assertion of the signal ensures the processor can capture the over-range event.

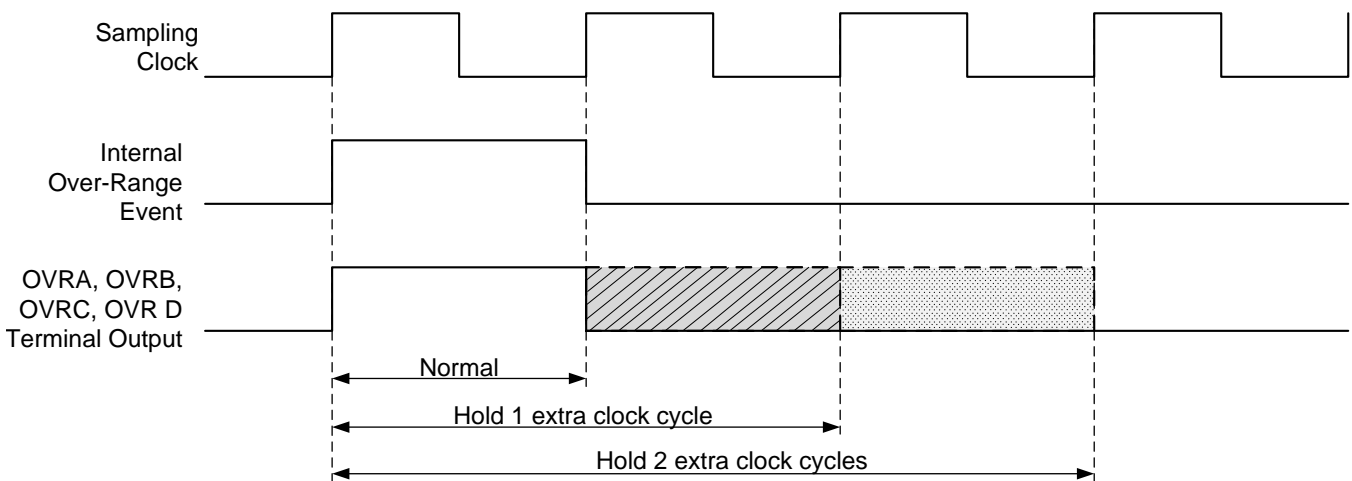

Figure 57. Fast Over Range Output Timing

The ADS54J54 device also provides the fast over-range indication bit in the JESD204B output data stream.

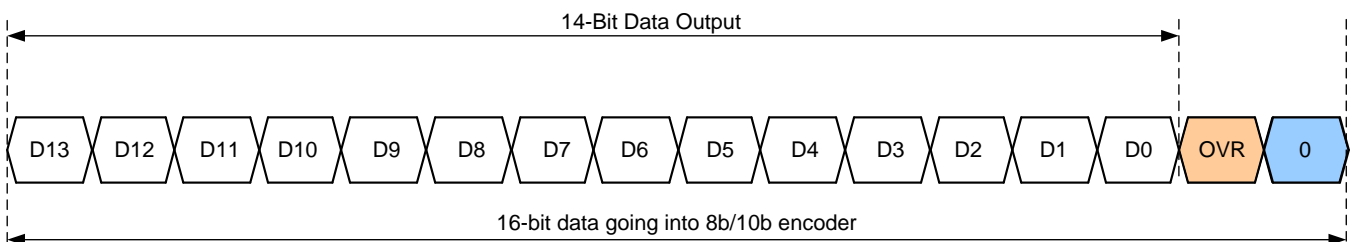

Figure 58. Sample Data and Status Bit Format

7.3.3 JESD204B Interface

The ADS54J54 supports device subclass 1 with a maximum output data rate of 5 Gbps for each serial transmitter. It allows independent JESD204B format configuration for channel A and B and channel C and D.

An external SYSREF signal is used to align all internal clock phases and the local multi-frame clock to a specific sampling clock edge. This allows synchronization of multiple devices in a system and minimizes timing and alignment uncertainty. SYNCbAB input is used to control all the JESD204B SerDes blocks for channel A and B while SYNCbCD is used to control channel C and D. If the same LMFS configuration is used for all four channels, the SYNCbAB and SYNCbCD signals can be tied together externally and driven from the same source.

Depending on the channel output data rate, the JESD204B output interface can be operated with either 1 or 2 lanes per single channel. The JESD204B setup and configuration of the frame assembly parameters are controlled via SPI interface.

The JESD204B transmitter block consists of the transport layer, the data scrambler and the link layer. The transport layer maps the channel output data into the selected JESD204B frame data format and manages if the channel output data or test patterns are being transmitted. The link layer performs the 8b/10b data encoding as well as the synchronization and initial lane alignment using the SYNCb input signal. Optionally, data from the transport layer can be scrambled.

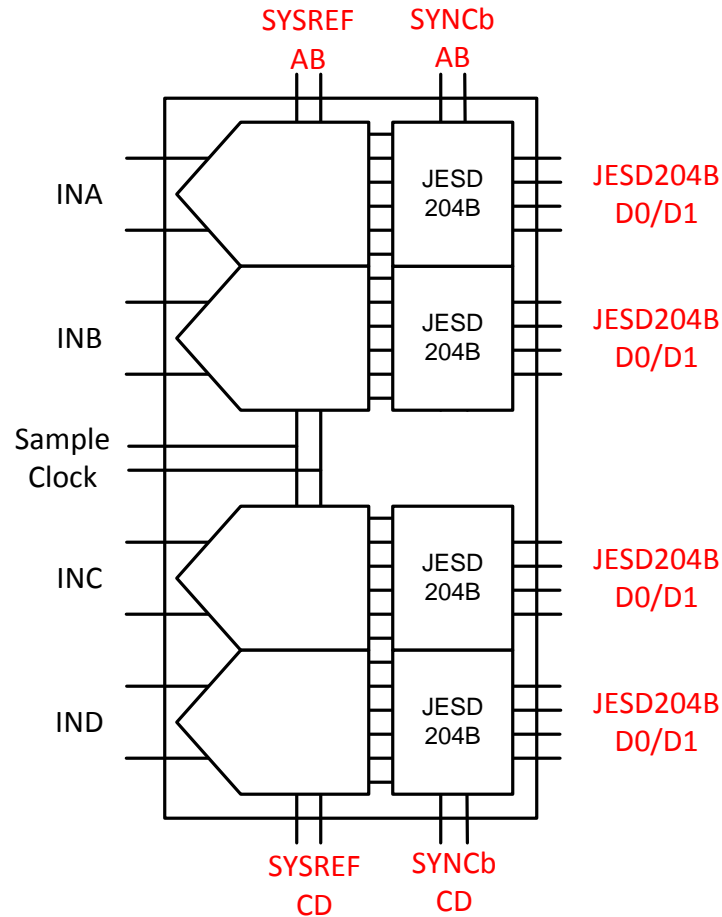

Figure 59. JESD204B Lane Assignment

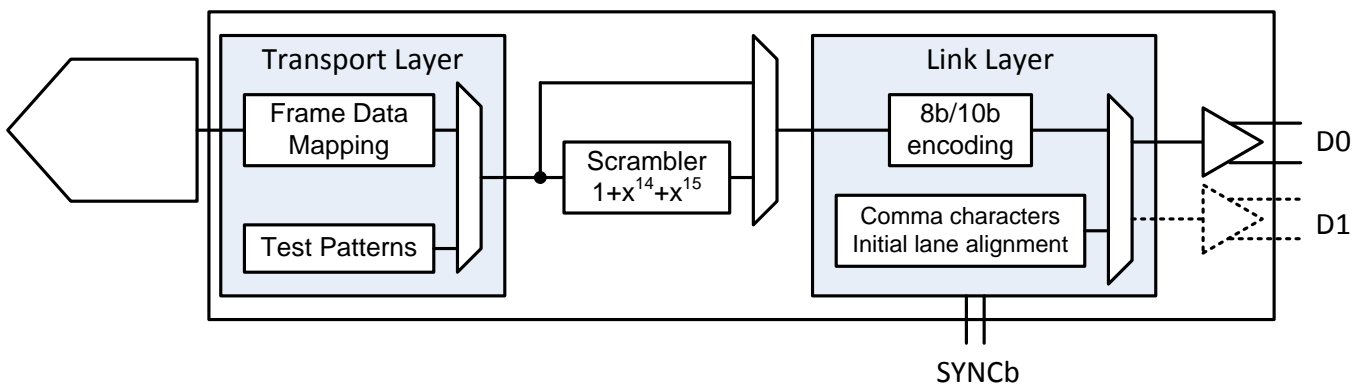

Figure 60. JESD204B Block

7.3.3.1 JESD204B Initial Lane Alignment (ILA)

The ILA process is started by the receiving device by deasserting the SYNCb signal. Upon detecting a logic low on the SYNCbAB input pins, the ADS54J54 device starts transmitting comma (K28.5) characters on channels A and B to establish code group synchronization. Upon detecting a logic high on the SYNCbCD input pins, the ADS54J54 device starts transmitting comma (K28.5) characters on channels C and D to establish code group synchronization.

After synchronization is completed, the receiving device asserts the SYNCb signal and the ADS54J54 starts the ILA sequence with the next local multi-frame clock boundary. The ADS54J54 device transmits 4 multi-frames each containing K frames (K is SPI programmable). Each of the multi-frames contains the frame start and end symbols and the second multi-frame also contains the JESD204 link configuration data.

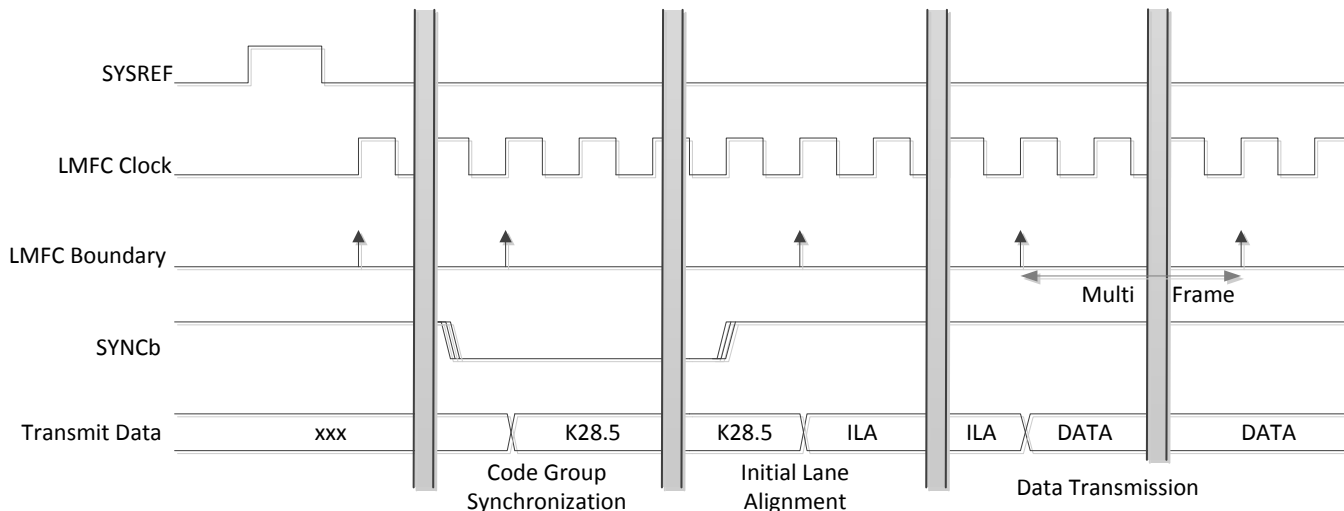

Figure 61. Initial Lane Assignment Format

7.3.3.2 JESD204B Test Patterns

There are three different test patterns available in the transport layer of the JESD204B interface. The ADS54J54 supports a RAMP, 1555/2AAA and different PRBS patterns. They can be enabled through SPI register write and are located in address 0x1D and 0x32/33.

7.3.3.3 JESD204B Frame Assembly

The JESD204B standard defines the following parameters:

- L = number of lanes per link
- M = number of converters for device
- F = number of octets per frame clock period
- S = number of samples per frame
- HD = high density mode

The ADS54J54 supports independent configuration of the JESD204B format for channel A and B and channel C and D. Table 2 lists the available JESD204B formats and valid ranges for the ADS54J54. The ranges are limited by the SerDes line rate and the maximum channel sample frequency.

Table 2. Permissible LMFS Settings

L	M	F	S	HD	Max Channel Output Rate (MSPS)	Max f_{SerDes} (Gpsps)
8	4	1	1	1	500	5.0
4	4	2	1	0	250	5.0

The detailed frame assembly is shown in [Table 3](#).

Table 3. LMFS Data Formats

	LMFS = 8411				LMFS = 4421					
Lane DA0	A0[13:6]	A1[13:6]	A2[13:6]	A3[13:6]	A0[13:6]	A0[5:0], 00	A1[13:6]	A1[5:0], 00	A2[13:6]	A2[5:0], 00
Lane DA1	A0[5:0], 00	A1[5:0], 00	A2[5:0], 00	A3[5:0], 00						
Lane DB0	B0[13:6]	B1[13:6]	B2[13:6]	B3[13:6]	B0[13:6]	B0[5:0], 00	B1[13:6]	B1[5:0], 00	B2[13:6]	B2[5:0], 00
Lane DB1	B0[5:0], 00	B1[5:0], 00	B2[5:0], 00	B3[5:0], 00						
Lane DC0	C0[13:6]	C1[13:6]	C2[13:6]	C3[13:6]	C0[13:6]	C0[5:0], 00	C1[13:6]	C1[5:0], 00	C2[13:6]	C2[5:0], 00
Lane DC1	C0[5:0], 00	C1[5:0], 00	C2[5:0], 00	C3[5:0], 00						
Lane DD0	D0[13:6]	D1[13:6]	D2[13:6]	D3[13:6]	D0[13:6]	D0[5:0], 00	D1[13:6]	D1[5:0], 00	D2[13:6]	D2[5:0], 00
Lane DD1	D0[5:0], 00	D1[5:0], 00	D2[5:0], 00	D3[5:0], 00						

7.3.4 SYSREF Clocking Schemes

Periodic: The SYSREF signal is always on. This mode is supported, but not recommended as the continuous SYSREF signal appears like an additional clock input, which can cause clock mixing spurs in the channel output spectrum.

Gapped-Periodic (recommended): A periodic SYSREF signal is presented to the ADS54J54 SYSREF inputs for a very short period of time. This configuration requires a DC-coupled SYSREF connection for proper operation. Most of the time the SYSREF signal is in a logic-low state, and thus cannot cause any glitches and spurs in the channel output spectrum.

Pulse/One Shot (recommended): A single SYSREF reset pulse is used to synchronize the ADS54J54. The ADS54J54 device requires a minimum of 3 SYSREF pulses to complete the synchronization phase. The SYSREF signal is in a logic-low state most of the time, and thus cannot cause any glitches and spurs in the channel output spectrum. Special attention should be given to ensure the single pulse meets required the SYSREF input setup and hold time.

7.3.5 Split-Mode Operation

The ADS54J54 provides several different options to interface it to the digital processor or processors. If the ADS54J54 device is operated in split sampling rate (2 channels at 500-MSPS output rate and 2 channels at 250-MSPS output rate), then it requires dual SYSREF (SYSREFAB and SYSREFCD) and dual SYNC (SYNCbAB and SYNCbCD).

Subclass 1 – Deterministic Latency: The device clock and synchronous SYSREF signal are provided by the timing unit to the ADS54J54 and the processor. The processor controls the SYNCb input signals for the JESD204B state machine for all four channels. In case the ADS54J54 is connected to two different processors, the differential SYNCb inputs of the ADS54J54 can be configured to two single-ended inputs where each pin controls the JESD204B state machine of the two corresponding channels.

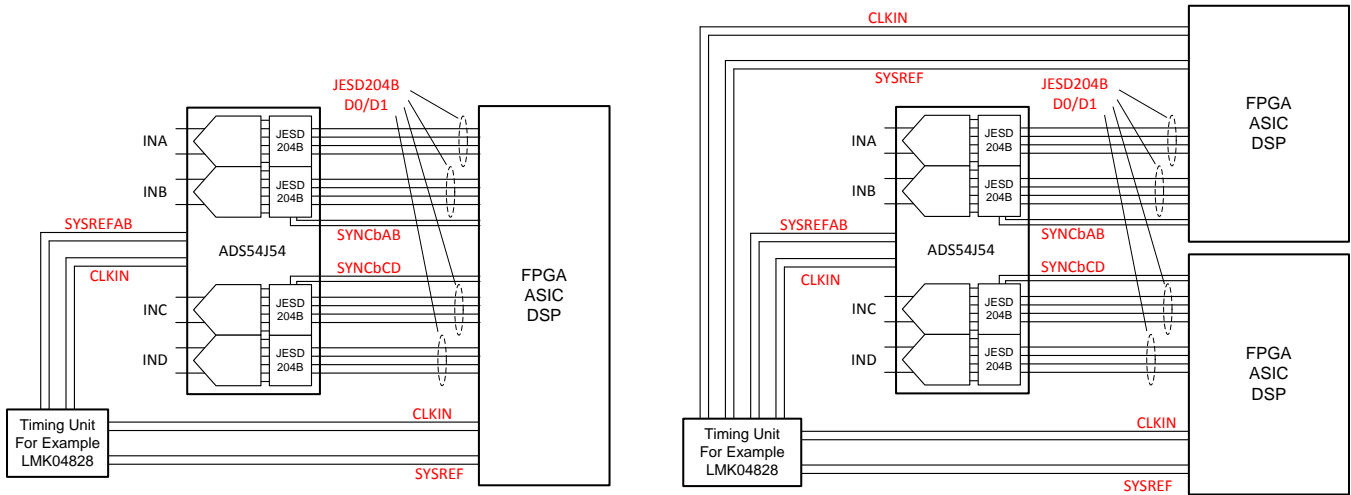

Figure 62. Four Channel and Dual Two Channel Usage

Split Mode Operation: If the ADS54J54 device is operated with 2-channel output at 500 MSPS and 2-channel output at 250 MSPS, then dual SYSREF (SYSREFAB for channel A and B, SYSREFCD for channel C and D) as well as dual SYNC (SYNCbAB for channel A and B, SYNCbCD for channel C and D) is required to ensure normal operation because the JESD204B link configuration is different for the two channel pairs.

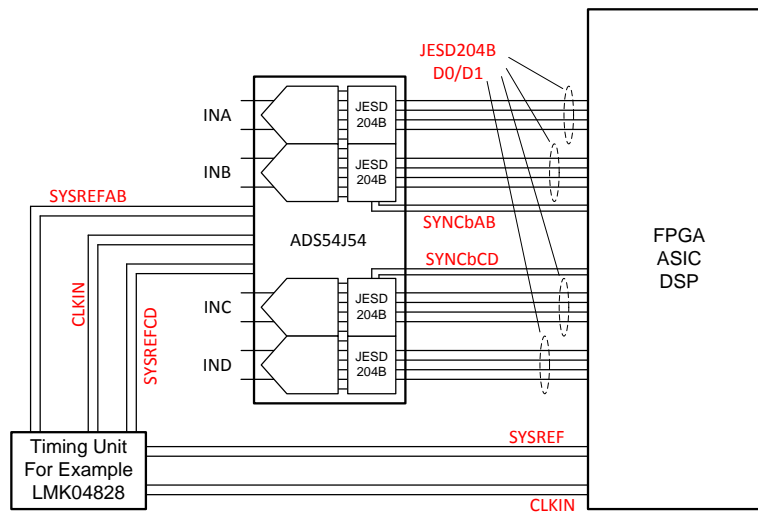
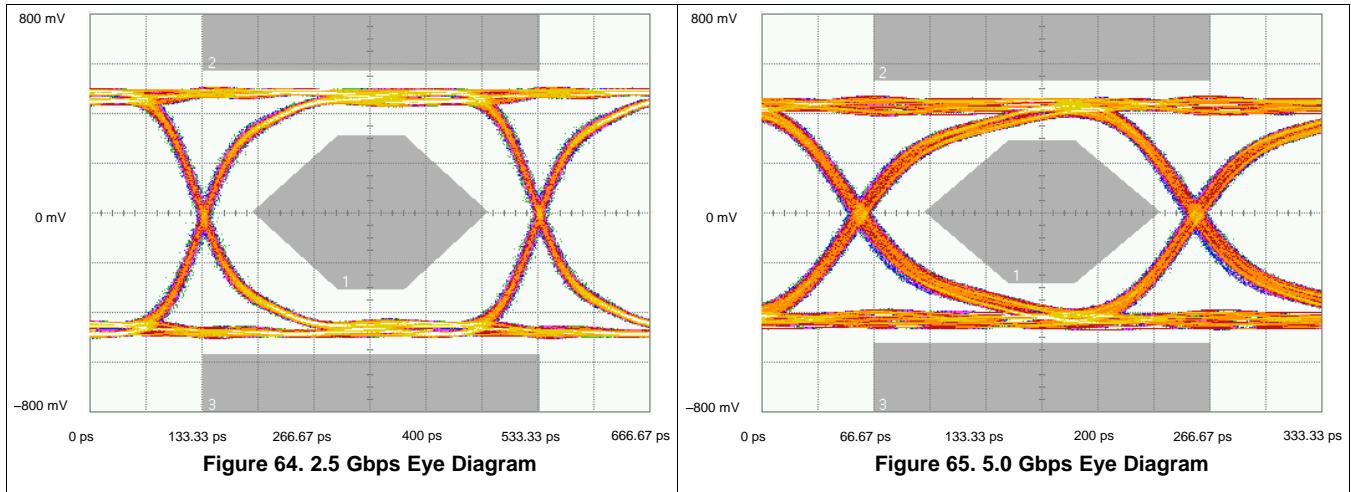

Figure 63. Dual SYSREF Usage

7.3.6 Eye Diagram Information

Figure 64 and Figure 65 is the measured eye diagram at 2.5 and 5 Gbps output data rate, respectively. These are overlaid with the JESD204B LV-OIF-6G-SR specification.



7.3.7 Analog Inputs

The ADS54J54 analog signal inputs are designed to be driven differentially. The analog input pins have internal analog buffers that drive the sampling circuit. As a result of the analog buffer, the input pins present a high-impedance input across a wide frequency range to the external driving source, which enables great flexibility in the external analog filter design as well as excellent 50-Ω matching for RF applications. The buffer also helps isolate the external driving circuit from the internal switching currents of the sampling circuit, which results in a more constant SFDR performance across input frequencies.

The common-mode voltage of the signal inputs is internally biased to 2 V using 500-Ω resistors, which allows for AC coupling of the input drive network. Each input pin (INP, INM) must swing symmetrically between (VCM + 0.3125 V) and (VCM – 0.3125 V), resulting in a 1.25-Vpp (default) differential input swing. The input sampling circuit has a 3-dB bandwidth that extends up to 900 MHz.

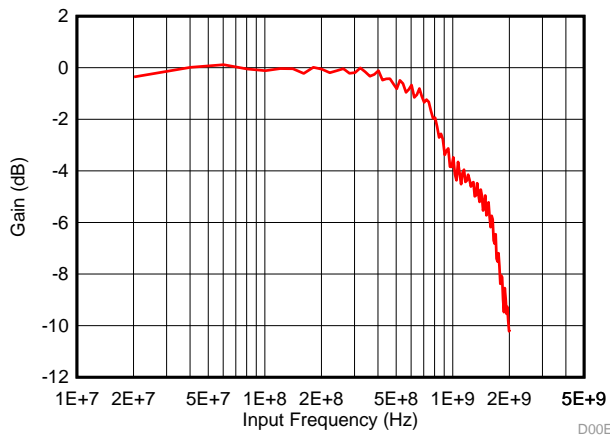

Figure 66. Normalized Input Bandwidth

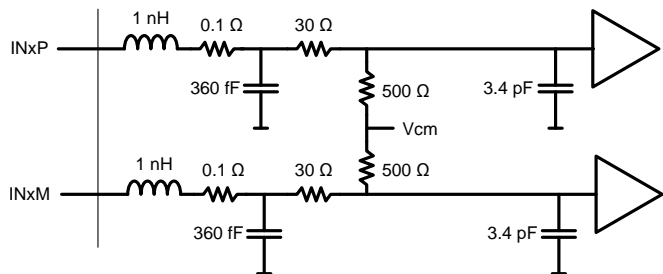

Figure 67. Equivalent Analog Input Circuit

7.3.8 Clock Inputs

The ADS54J54 clock input can be driven differentially with a sine wave or LVPECL source with little or no difference in performance. The common mode voltage of the clock input is set to 0.9 V using internal 2-k Ω resistors. This allows for AC coupling of the clock inputs. The termination resistors should be placed as close as possible to the clock inputs in order to minimize signal reflections and jitter degradation.

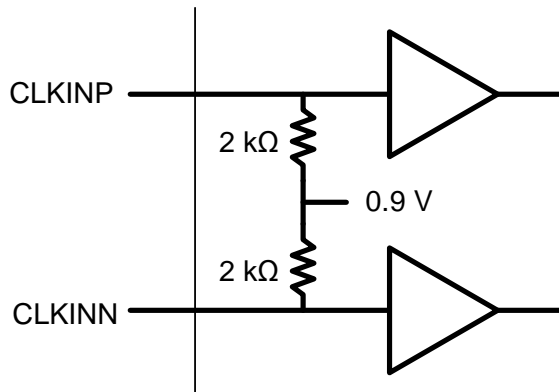

Figure 68. Equivalent Clock Input Circuit

7.3.9 Input Clock Divider

The ADS54J54 is equipped with two internal dividers on the clock input – one on channel AB and one on channel CD. The clock divider allows operation with a faster input clock simplifying the system clock distribution design. The clock dividers can be bypassed (/1) for operation with a 500-MHz clock while /2 option supports a maximum input clock of 1 GHz and the /4 option a maximum input clock frequency of 2 GHz. Different divider options can be selected for channel AB and channel CD clock output. By default the divider output of channel AB block is routed to all 4 channels but the configuration can be customized with different SPI register settings to use either the channel AB or CD divider blocks for any two channels.

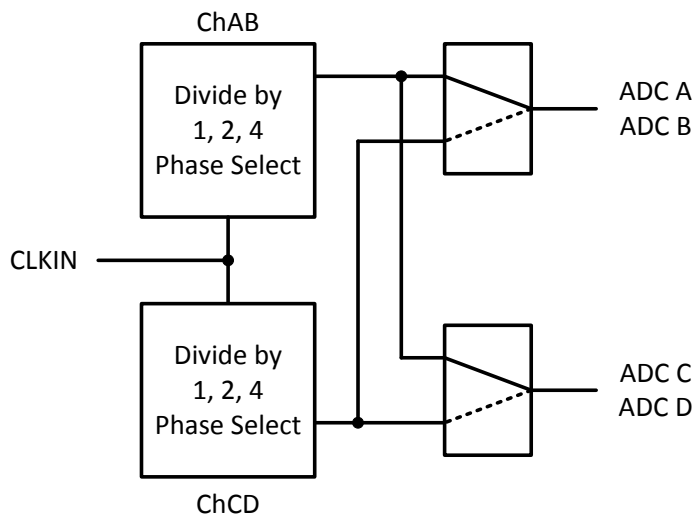

Figure 69. Input Clock Divider

7.3.10 Power-Down Control

The power down functions of the ADS54J54 can be controlled either through the parallel control pin (ENABLE) or through a SPI register setting. Power-down modes for the different channels as well as for the JESD204B interface are supported.

The ADS54J54 supports the following power-down modes. The analog sleep mode configurations are in register 0x05/06 and the JESD204b sleep mode configurations are in register 0x1E and 0x1F.

Table 4. Low-Power Mode Power Consumption and Wake-Up Times

Configuration	Power Consumption	Wake-Up Time
Global power down	24 mW	Needs JESD resynch
Standby	31 mW	Needs JESD resynch
Deep sleep	791 mW	1.4 ms
Light sleep	1.68 W	8 μ s

Control power-down function through ENABLE pin:

1. Configure power-down mode in register 0x05 and 0x1E
2. Normal operation: ENABLE pin high
3. Power-down mode: ENABLE pin low

Control power-down function through SPI (ENABLE pin always high):

1. Assign power-down mode in register 0x06 and 0x1F
2. Normal operation: 0x06 and 0x1F are 0xFFFF
3. Power-down mode: configure power down mode in register 0x06 and 0x1F

7.3.11 Device Configuration

The serial interface (SIF) included in the ADS54J54 is a simple 3- or 4-pin interface. In normal mode, 3 pins are used to communicate with the device. There is an enable (SDENb), a clock (SCLK), and a bidirectional IO port (SDATA). If the user would like to use the 4-pin interface, one write must be implemented in the 3-pin mode to enable 4-pin communications. In this mode, the SDOOUT pin becomes the dedicated output. The serial interface has an 8-bit address word and a 16-bit data word. The first rising edge of SCLK after SDENb goes low will latch the read or write bit. If a high is registered, then a read is requested, if it is low, then a write is requested. SDENb must be brought high again before another transfer can be requested.

7.3.12 JESD204B Interface Initialization Sequence

After power-up, the internal JESD204B digital block must be initialized with the following sequence of steps:

1. Set JESD RESET AB/CD and JESD INIT AB/CD to 0 (address 0x0D, value 0x0000)
2. Set JESD INIT AB/CD to 1 (0x0D, 0x0202)
3. Set JESD RESET AB/CD to 1 (0x0D, 0x0303)
4. Configure all other JESD register and clock settings. If those settings change later on, this initialization sequence must be repeated.
5. Set JESD RESET AB/CD to 0 (0x0D, 0x0202)
6. Set JESD RESET AB/CD to 1 (0x0D, 0x0303)
7. Wait for two SYSREF pulses
8. Set JESD INIT AB/CD to 0 (0x0D, 0x0101)

7.3.13 Device and Register Initialization

After power-up, the internal registers must be initialized to their default values through a hardware reset by applying a low pulse on the SRESETb pin (of width greater than 10 ns), as shown in [Figure 1](#). If required later during operation, the serial interface registers can be cleared by applying:

- Another hardware reset using the SRESETb pin
- A software reset (bit D0 in register 0x00). This setting resets the internal registers to the default values and then self-resets the RESET bit (D0) back to 0. In this case, the RESET pin is kept high.
- Write the data in [Table 5](#) to the following registers after every device power-up or reset for optimum AC performance:

Table 5. AC Performance

ADDRESS	DATA	REASON
0x06	0xFFDF	turn off fuse logic for power savings - not required
0x44	0x0074	trim value - required
0x47	0x0074	trim value - required
0x4C	0x4000	trim value - required
0x50	0x0800	trim value - required
0x51	0x0074	trim value - required
0x54	0x0074	trim value - required
0x59	0x4000	trim value - required
0x5D	0x0800	trim value - required

7.4 Device Functional Modes

7.4.1 Operating Modes

[Table 6](#) details the five different operating modes. A pair of channels (channel A and B and channel C and D) can be configured in the same operating mode.

Table 6. Operating Modes Information

Channel Sampling Rate (MSPS)	Digital Feature	Output Data Rate (MSPS)	Output Resolution	Output SerDes Rate (GSPS)	Number of Lanes per Channel
500	Decimation by 2	250	14 bit	5.0	1
500	Bypass digital logic mode	500	14 bit	5.0	2

7.4.2 Output Format

Table 7 provides detailed information on how the MSB or LSB get aligned for the different output data rates and resolution in the different operating modes.

Table 7. Output Data Formats

Output Rate	Mode	Resolution	Bit 15	Bit 14	Bit 13	Bit 12	Bit 11	Bit 10	Bit 9	Bit 8	Bit 7	Bit 6	Bit 5	Bit 4	Bit 3	Bit 2	Bit 1	Bit 0
250 MSPS	Decimate by 2	14 bit	D13	D12	D11	D10	D9	D8	D7	D6	D5	D4	D3	D2	D1	D0	OVR	0
500 MSPS	Bypass digital logic mode	14 bit	D13	D12	D11	D10	D9	D8	D7	D6	D5	D4	D3	D2	D1	D0	OVR	0

7.5 Programming

7.5.1 Serial Register Write

The internal register of the ADS54J54 can be programmed following these steps:

1. Drive SDENb pin low.
2. Set the R/W bit to '0' (bit A7 of the 8 bit address).
3. Initiate a serial interface cycle specifying the address of the register (A6 to A0) whose content has to be written.
4. Write 16-bit data which is latched on the rising edge of SCLK.

Table 8. Serial Register Read or Write Timing⁽¹⁾

PARAMETER	MIN	TYP	MAX	UNIT
f_{SCLK} SCLK frequency (equal to $1 / t_{SCLK}$)	>DC		10	MHz
t_{SLOADS} SDENb to SCLK setup time	50			ns
t_{SLOADH} SCLK to SDENb hold time	50			ns
t_{DSU} SDATA setup time	50			ns
t_{DH} SDATA hold time	50			ns

(1) Typical values at 25°C; minimum and maximum values across the full temperature range: $T_{MIN} = -40^{\circ}C$ to $T_{MAX} = 85^{\circ}C$, AVDD33 = 3.3 V; AVDD18 = 1.9 V; AVDDC, DVDD, IOVDD, PLLVDD = 1.8 V, unless otherwise noted.

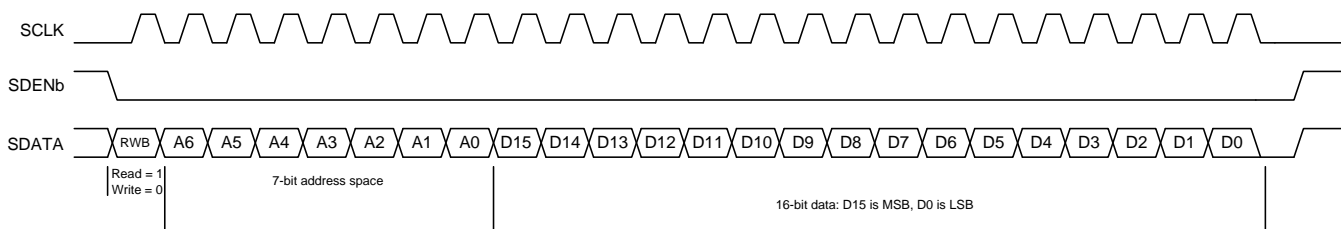

Figure 70. Serial Register Write Timing Diagram

7.5.2 Serial Register Readout

The device includes a mode where the contents of the internal registers can be read back using the SDOOUT and SDATA pins. This read-back mode may be useful as a diagnostic check to verify the serial interface communication between the external controller and the channel.

1. Drive SDENb pin low.
2. Set the RW bit (A7) to 1. This setting disables any further writes to the registers.
3. Initiate a serial interface cycle specifying the address of the register (A6 to A0) whose content has to be read.
4. The device outputs the contents (D15 to D0) of the selected register on the SDOOUT/SDATA pin.
5. The external controller can latch the contents at the SCLK rising edge.
6. To enable register writes, reset the RW register bit to 0.

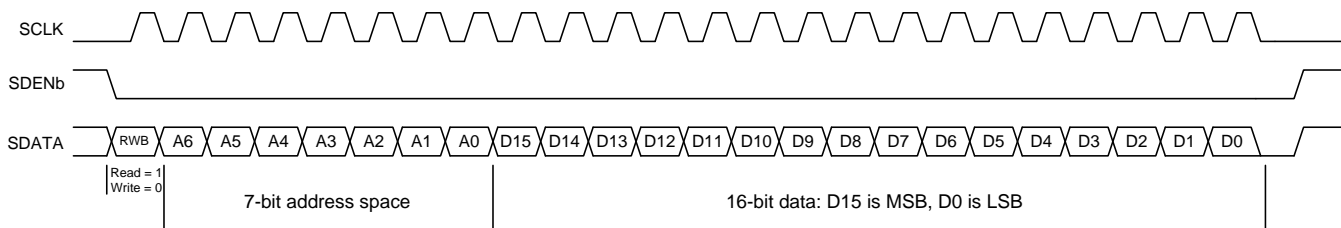

Figure 71. Serial Register Read Timing Diagram

7.6 Register Maps

Register Address	Register Data																
	A7 to A0 in hex	D15	D14	D13	D12	D11	D10	D9	D8	D7	D6	D5	D4	D3	D2	D1	D0
0	3/4 WIRE	FORMAT	DEC EN AB	HP/LP AB	0	DEC EN CD	HP/LP CD	0	0	0	0	0	0	0	0	0	RESET
1	MODE 1	0	1	0	FOVR THRESH AB			FOVR LENGTH AB			FOVR THRESH CD			FOVR LENGTH CD		1	0
2	0	1	0		0	0	0	0	0	0	0	0	0	0	0	0	0
3	0	CLK SEL CD	CLK DIV CD		0	CLK PHASE SELECT CD			SYSREF SEL CD	CLK SEL AB	CLK DIV AB		0	CLK PHASE SELECT AB			
4	OVRA OUT EN	OVRB OUT EN	OVRC OUT EN	OVRD OUT EN	SYSREF AB DELAY		SYSREF CD DELAY		0	0	0	0	0	SYNCb AB EN	SYNCb CD EN	1	1
5	ANALOG SLEEP MODES – ENABLE PIN																
6	ANALOG SLEEP MODES – SPI																
7	0	0	0	0	0	0	0	CLK SW AB	1	0	1	0	0	0	1	0	0
8	0	0	0	0	0	0	0	CLK SW CD	1	0	1	0	0	0	1	0	0
C	0	0	1	1	0	0	0	0	1	1	1	SYSREF JESD MODE CD			SYSREF JESD MODE AB		
D	0	0	0	0	0	0	0	JESD INIT CD	JESD RESET CD	0	0	0	0	0	0	JESD INIT AB	JESD RESET AB
E	0	0	0	0	0	0	0	0	0	TX LANE EN CD				TX LANE EN AB			
F	0	0	0	0	0	0	0	CTRL F AB		0	0	0	0	0	0	CTRL M AB	
10	0	0	0	0	0	0	0	CTRL K AB		0		0	0	0	CTRL L AB		
13	0	0	0	0	0	0	0	0	0	0	INV SYNCb AB	HD AB	SCR EN AB	0	0	0	0
16	0	0	0	0	0	0	0	CTRL F CD		0	0	0	0	0	0	CTRL M CD	
17	0	0	0	0	0	0	CTRL K CD				0	0	0	CTRL L CD			
1A	0	0	0	0	0	0	0	0	0	0	INV SYNCb CD	HD CD	SCR EN CD	0	0	0	0
1D	0	0	0	0	0	0	0	0	0	0	TEST PATTERN EN CD	TEST PATTERN EN AB	0	TEST PATTERN	0	0	0
1E	0	0	0	0	0	0	JESD SLEEP MODES – ENABLE PIN										
1F	1	1	1	1	1	1	JESD SLEEP MODES – SPI										
20	JESD LANE POLARITY INVERT								PRBS EN								
21	0	PRBS SEL		0	0	0	0	0	0	0	0	0	0	0	VREF SEL		
63	0	0		0	0	0	0	0	TEMP SENSOR								
64	PRE EMP SEL AB				PRE EMP EN AB				DCC EN AB				0	0	0	0	
67	OUTPUT CURRENT CONTROL AB																
68	PRE EMP SEL CD				PRE EMP EN CD				DCC EN CD				0	0	0	0	
6B	OUTPUT CURRENT CONTROL CD																
6C	0	0	0	0	0	0	0	0	0	0	0	0	0	0	0	JESD PLL CD	JESD PLL AB

7.6.1 Register Descriptions

7.6.1.1 Register Address 0

Figure 72. Register Address 0, Reset 0x0000, Hex = 0

D15	D14	D13	D12	D11	D10	D9	D8	D7	D6	D5	D4	D3	D2	D1	D0
3/4 WIRE	FORMAT	DEC EN AB	HP/LP AB	0	DEC EN CD	HP/LP CD	0	0	0	0	0	0	0	0	RESET

LEGEND: R/W = Read/Write; R = Read only; -n = value after reset

Table 9. Register Address 0 Field Descriptions

Bit	Field	Type	Reset	Description
D15	3/4 WIRE	R/W	0	Enables 4-bit serial interface when set 0 = 3-wire SPI (SDATA is bidirectional) 1 = 4-wire SPI (SDOUT is data output)
D14	FORMAT	R/W	0	Selects digital output format 0 = Output is 2s complement 1 = Offset binary
D13	DEC EN AB	R/W	0	Enables decimation filter for channel AB 0 = Normal operation 1 = Decimation filter enabled
D12	HP/LP AB	R/W	0	Determines high-pass or low-pass configuration of decimation filter for channel AB 0 = Low pass 1 = High pass
D10	DEC EN CD	R/W	0	Enables decimation filter for channel CD 0 = Normal operation 1 = Decimation filter enabled
D9	HP/LP CD	R/W	0	Determines high-pass or low-pass configuration of decimation filter for channel CD 0 = Low pass 1 = High pass
D0	RESET	R/W	0	Software reset, self clears to 0 0 = Normal operation 1 = Execute software reset

7.6.1.2 Register Address 1

Figure 73. Register Address 1, Reset 0xAF7A, Hex = 1

D15	D14	D13	D12	D11	D10	D9	D8	D7	D6	D5	D4	D3	D2	D1	D0
MODE 1	0	1	0	FOVR THRESH AB			FOVR LENGTH AB		FOVR THRESH CD			FOVR LENGTH CD		1	0

LEGEND: R/W = Read/Write; R = Read only; -n = value after reset

Table 10. Register Address 1 Field Descriptions

Bit	Field	Type	Reset	Description
D15	MODE 1	R/W	1	Set bit D15 to 0 for optimum performance
D13		R	1	Reads back 1
D11:D9	FOVR THRESH AB	R/W	111	<p>Sets fast OVR thresholds for channel A and B The fast over-range detection is triggered 6 output clock cycles after the overload condition occurs. The threshold at which the OVR is triggered is: Input full scale × [decimal value of <over-range threshold>] / 8. After power-up or reset, the default value is 7 (decimal), which corresponds to an OVR threshold of 1.16-dB below full scale (20 × log(7/8)).</p>  <p style="text-align: right; font-size: small;">D00F</p>
D8:D7	FOVR LENGTH AB	R/W	10	<p>Determines minimum pulse length for FOVR output 00 = 1 clock cycle 01 = 2 clock cycles 10 = 4 clock cycles 11 = 8 clock cycles</p>
D6:D4	FOVR THRESH CD	R/W	111	Sets fast OVR thresholds for channel C and D See description for channel A and B
D3:D2	FOVR LENGTH CD	R/W	10	<p>Determines minimum pulse length for FOVR output 00 = 1 clock cycle 01 = 2 clock cycles 10 = 4 clock cycles 11 = 8 clock cycles</p>
D1		R	1	Reads back 1

Figure 74. OVR Detection Threshold

7.6.1.3 Register Address 3

Figure 75. Register Address 3, Reset: 0x4040, Hex = 3

D15	D14	D13	D12	D11	D10	D9	D8	D7	D6	D5	D4	D3	D2	D1	D0
0	CLK SEL CD	CLK DIV CD		0	CLK PHASE SELECT CD		SYSREF SEL CD	CLK SEL AB	CLK DIV AB		0	CLK PHASE SELECT AB			

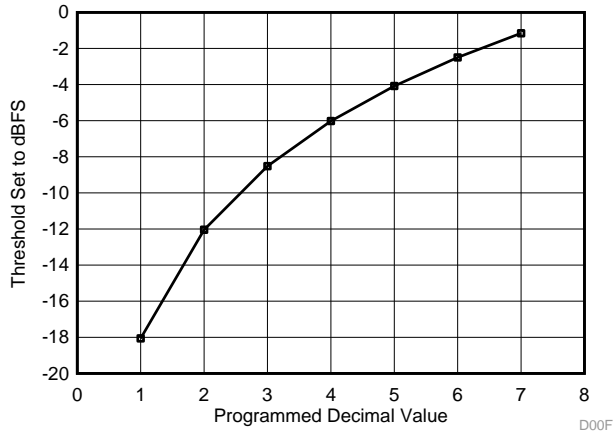
LEGEND: R/W = Read/Write; R = Read only; -n = value after reset

Table 11. Register Address 3 Field Descriptions

Bit	Field	Type	Reset	Description
D14	CLK SEL CD	R/W	1	Clock source selection for channel C and D 0 = Channel CD clock output divider 1 = Channel AB clock output divider (default)
D13:D12	CLK DIV CD	R/W	00	Channel CD clock divider setting 00 = Clock input is up to 500 MHz. Input clock is not divided (default) 01 = /2 10 = /4 11 = Not used
D10:D8	CLK PHASE SELECT CD	R/W	000	Selects phase of channel divided clock, but depends on clock divider setting. When clock CD divider is set to: /1 = 2 phases are available (0° or 180°) /2 = 4 phases are available (0°, 90°, 180° or 270°) /4 = 8 phases are available (0°, 45°, 90°, 135°, 180°, 225°, 270° or 315°) When switching clock phases, register 0x08, D9 must be enabled first and then disabled after the switch to ensure glitch-free operation.
D7	SYSREF SEL CD	R/W	0	SYSREF Input selection for channel C and D 0 = Use SYSREFAB inputs (default) 1 = Use SYSREFCD inputs
D6	CLK SEL AB	R/W	1	Clock source selection for channel A and B 0 = Channel CD clock output divider 1 = Channel AB clock output divider (default)
D5:D4	CLK DIV AB	R/W	00	Channel AB clock divider setting 00 = Clock input is up to 500 MHz. Input clock is not divided (default) 01 = /2 10 = /4 11 = Not used
D2:D0	CLK PHASE SELECT AB	R/W	000	Selects phase of channel AB divided clock, but depends on clock divider setting. When clock divider is set to: /1 = 2 phases are available (0° or 180°) /2 = 4 phases are available (0°, 90°, 180° or 270°) /4 = 8 phases are available (0°, 45°, 90°, 135°, 180°, 225°, 270° or 315°) When switching clock phases, register 0x07, D9 must be enabled first and then disabled after the switch to ensure glitch-free operation.

7.6.1.4 Register Address 4

Figure 76. Register Address 4, Reset: 0x000F, Hex = 4

D15	D14	D13	D12	D11	D10	D9	D8	D7	D6	D5	D4	D3	D2	D1	D0
OVRA OUT EN	OVRB OUT EN	OVRC OUT EN	OVRD OUT EN	SYSREF AB DELAY	SYSREF CD DELAY	0	0	0	0	0	0	SYNCb AB EN	SYNCb CD EN	1	1

LEGEND: R/W = Read/Write; R = Read only; -n = value after reset

Table 12. Register Address 4 Field Descriptions

Bit	Field	Type	Reset	Description
D15	OVRA OUT EN	R/W	0	OVRA pin output enable 0 = Not used (default) 1 = OVRA is an output
D14	OVRB OUT EN	R/W	0	OVRB pin output enable 0 = Not used (default) 1 = OVRB is an output
D13	OVRC OUT EN	R/W	0	OVRC pin output enable 0 = Not used (default) 1 = OVRC is an output
D12	OVRD OUT EN	R/W	0	OVRD pin output enable 0 = Not used (default) 1 = OVRD is an output
D11:D10	SYSREF AB DELAY	R/W	00	Programmable input delay on SYSREFAB input 00 = 0-ps delay (default) 01 = 200-ps delay 10 = 100-ps delay 11 = 300-ps delay
D9:D8	SYSREF CD DELAY	R/W	00	Programmable input delay on SYSREFCD input 00 = 0-ps delay (default) 01 = 200-ps delay 10 = 100-ps delay 11 = 300-ps delay
D3	SYNCb AB EN	R/W	1	SYNCbAB input buffer enable 0 = Input buffer disabled 1 = Input buffer enabled (default)
D2	SYNCb CD EN	R/W	1	SYNCbCD input buffer enable 0 = Input buffer disabled 1 = Input buffer enabled (default)
D1		R	1	Reads back 1
D0		R	1	Reads back 1

7.6.1.5 Register Address 5
Figure 77. Register Address 5, Reset: 0x0000, Hex = 5

D15	D14	D13	D12	D11	D10	D9	D8	D7	D6	D5	D4	D3	D2	D1	D0
ANALOG SLEEP MODES – ENABLE pin															

LEGEND: R/W = Read/Write; R = Read only; -n = value after reset

Table 13. Register Address 5 Field Descriptions

Bit	Field	Type	Reset	Description
D15:D0	ANALOG SLEEP MODES – ENABLE pin	R/W		Power-down function assigned to ENABLE pin. When any bit is set, the corresponding function is always enabled regardless of status of the ENABLE pin. This assumes address 0x06 is in default configuration.
D13		R/W	0	Light sleep channel A
D11		R/W	0	Light sleep channel B
D9		R/W	0	Light sleep channel C
D7		R/W	0	Light sleep channel D
D6		R/W	0	Temperature sensor
D4		R/W	0	Clock buffer
D3		R/W	0	Clock divider channel AB
D2		R/W	0	Clock divider channel CD
D1		R/W	0	Buffer SYSREFAB
D0		R/W	0	Buffer SYSREFCD

Table 14. Configurations When ENABLE Pin is Low

	Description
0000 0000 0000 0000	Global power down
1000 0000 0000 0000	Standby
1000 0000 0001 1111	Deep sleep
1010 1010 1001 1111	Light sleep (if unused, clock divider CD and SYSREFCD can be set to 0 also)

7.6.1.6 Register Address 6

Figure 78. Register Address 6, Reset: 0xFFFF, Hex = 6

D15	D14	D13	D12	D11	D10	D9	D8	D7	D6	D5	D4	D3	D2	D1	D0
ANALOG SLEEP MODES – SPI															1

LEGEND: R/W = Read/Write; R = Read only; -n = value after reset

Table 15. Register Address 6 Field Descriptions

Bit	Field	Type	Reset	Description
D15:D1	ANALOG SLEEP MODES – SPI			Power-down function controlled via SPI. When a bit is set to 0, the function is powered down when ENABLE pin is high. However, register 0x05 has higher priority. For example, if D13 (deep sleep channel A) in 0x05 is enabled, it cannot be powered down with the SPI.
D13		R/W	1	Light sleep channel A
D11		R/W	1	Light sleep channel B
D9		R/W	1	Light sleep channel C
D7		R/W	1	Light sleep channel D
D6		R/W	1	Temperature sensor
D4		R/W	1	Clock buffer
D3		R/W	1	Clock divider channel AB
D2		R/W	1	Clock divider channel CD
D1		R/W	1	Buffer SYSREFAB
D0		R/W	1	Should be left set to 1

Table 16. Configurations When ENABLE Pin is High

	Description
0000 0000 0000 000	Global power down
1000 0000 0000 000	Standby
1000 0000 0001 111	Deep sleep
1010 1010 1001 111	Light sleep
1111 1111 1111 111	Normal operation

Control power down function through ENABLE pin:

1. Configure power-down mode in register 0x05
2. Normal operation: ENABLE pin high
3. Power-down mode: ENABLE pin low

Control power down function through SPI (ENABLE pin always high):

1. Assign power-down mode in register 0x06
2. Normal operation 0x06 is 0xFFFF
3. Power-down mode: configure power down mode in register 0x06

7.6.1.7 Register Address 7

Figure 79. Register Address 7, Reset: 0x0144, Hex = 7

D15	D14	D13	D12	D11	D10	D9	D8	D7	D6	D5	D4	D3	D2	D1	D0
0	0	0	0	0	0	CLK SW AB	1	0	1	0	0	0	1	0	0

LEGEND: R/W = Read/Write; R = Read only; -n = value after reset

Table 17. Register Address 7 Field Descriptions

Bit	Field	Type	Reset	Description
D9	CLK SW AB	R/W	0	User should set this bit to 1 when changing the clock phase of the clock divider AB. After the change is complete user needs to write this bit back to 0.
D8		R	1	Reads back 1
D6		R	1	Reads back 1
D2		R	1	Reads back 1

7.6.1.8 Register Address 8

Figure 80. Register Address 8, Reset: 0x0144, Hex = 8

D15	D14	D13	D12	D11	D10	D9	D8	D7	D6	D5	D4	D3	D2	D1	D0
0	0	0	0	0	0	CLK SW CD	1	0	1	0	0	0	1	0	0

LEGEND: R/W = Read/Write; R = Read only; -n = value after reset

Table 18. Register Address 8 Field Descriptions

Bit	Field	Type	Reset	Description
D9	CLK SW CD	R/W	0	User should set this bit to 1 when changing the clock phase of the clock divider CD. After the change is complete user needs to write this bit back to 0.
D8		R	1	Reads back 1
D6		R	1	Reads back 1
D2		R	1	Reads back 1

7.6.1.9 Register Address 12

Figure 81. Register Address 12, Reset: 0x31E4, Hex = C

D15	D14	D13	D12	D11	D10	D9	D8	D7	D6	D5	D4	D3	D2	D1	D0
0	0	1	1	0	0	0	1	1	1	SYSREF JESD MODE CD			SYSREF JESD MODE AB		

LEGEND: R/W = Read/Write; R = Read only; -n = value after reset

Table 19. Register Address 12 Field Descriptions

Bit	Field	Type	Reset	Description
D13		R	1	Reads back 1
D12		R	1	Reads back 1
D8		R	1	Reads back 1
D7		R	1	Reads back 1
D6		R	1	Reads back 1

Table 19. Register Address 12 Field Descriptions (continued)

Bit	Field	Type	Reset	Description
D5:D3	SYSREF JESD MODE CD	R/W	100	Determines how SYSREF is used in the JESD block for channel CD 000 = Ignore SYSREF input 001 = Use all SYSREF pulses 010 = Use only the next SYSREF pulse 011 = Skip one SYSREF pulse then use only the next one 100 = Skip one SYSREF pulse then use all pulses (default) 101 = Skip two SYSREF pulses and then use one 111 = Skip two SYSREF pulses and then use all
D2:D0	SYSREF JESD MODE AB	R/W	100	Determines how SYSREF is used in the JESD block for channel AB. Same functionality as SYSREF JESD MODE CD

7.6.1.10 Register Address 13

Figure 82. Register Address 13, Reset: 0x0202, Hex = D

D15	D14	D13	D12	D11	D10	D9	D8	D7	D6	D5	D4	D3	D2	D1	D0
0	0	0	0	0	0	JESD INIT CD	JESD RESET CD	0	0	0	0	0	0	JESD INIT AB	JESD RESET AB

LEGEND: R/W = Read/Write; R = Read only; -n = value after reset

Table 20. Register Address 13 Field Descriptions

Bit	Field	Type	Reset	Description
D9	JESD INIT CD	R/W	1	Puts the JESD block in INITIALIZATION state when set high. In this state the JESD parameters can be programmed and the outputs will stay at 0. See also JESD start-up sequence.
D8	JESD RESET CD	R/W	0	Resets the JESD block when low
D1	JESD INIT AB	R/W	1	Puts the JESD block in initialization state when set high. In this state the JESD parameters can be programmed and the outputs will stay at 0.
D0	JESD RESET AB	R/W	0	Resets the JESD block when low

7.6.1.11 Register Address 14

Figure 83. Register Address 14, Reset: 0x00FF, Hex = E

D15	D14	D13	D12	D11	D10	D9	D8	D7	D6	D5	D4	D3	D2	D1	D0
0	0	0	0	0	0	0	0	TX LANE EN CD				TX LANE EN AB			

LEGEND: R/W = Read/Write; R = Read only; -n = value after reset

Table 21. Register Address 14 Field Descriptions

Bit	Field	Type	Reset	Description
D7:D4	TX LANE EN CD	R/W	1111	Enables JESD204B transmitter for channel C and D. Set to 1 to enable. D7 = Lane DD1 D6 = Lane DD0 D5 = Lane DC1 D4 = Lane DC0
D3:D0	TX LANE EN AB	R/W	1111	Enables JESD204B transmitter for channel A and B. Set to 1 to enable. D3 = Lane DB1 D2 = Lane DB0 D1 = Lane DA1 D0 = Lane DA0

7.6.1.12 Register Address 15

Figure 84. Register Address 15, Reset: 0x0001, Hex = F

D15	D14	D13	D12	D11	D10	D9	D8	D7	D6	D5	D4	D3	D2	D1	D0
0	0	0	0	0	0	CTRL F AB		0	0	0	0	0	0	CTRL M AB	

LEGEND: R/W = Read/Write; R = Read only; -n = value after reset

Table 22. Register Address 15 Field Descriptions

Bit	Field	Type	Reset	Description
D9:D8	CTRL F AB	R/W	00	Controls number of octets per frame for channel AB. 00 = F = 1 (default) 01 = F = 2
D1:D0	CTRL M AB	R/W	01	Controls number of converters per link for channel AB. 01 = M = 2. This is the only valid option (default)

7.6.1.13 Register Address 16

Figure 85. Register Address 16, Reset: 0x03E3, Hex = 10

D15	D14	D13	D12	D11	D10	D9	D8	D7	D6	D5	D4	D3	D2	D1	D0	
0	0	0	0	0	0	CTRL K AB					0	0	0	CTRL L AB		

LEGEND: R/W = Read/Write; R = Read only; -n = value after reset

Table 23. Register Address 16 Field Descriptions

Bit	Field	Type	Reset	Description
D9:D5	CTRL K AB	R/W	11111	Controls number of frames per multi-frame for channel AB. 0: K = 1 30 K = 31 1: K = 2 31 K = 32 (default) And so forth
D1:D0	CTRL L AB	R/W	11	Controls number of lanes for channel AB. 01: L = 2 11: L = 4 (default)

7.6.1.14 Register Address 19

Figure 86. Register Address 19, Reset: 0x0020, Hex = 13

D15	D14	D13	D12	D11	D10	D9	D8	D7	D6	D5	D4	D3	D2	D1	D0
0	0	0	0	0	0	0	0	0	INV SYNCb AB	HD AB	SCR EN AB	0	0	0	0

LEGEND: R/W = Read/Write; R = Read only; -n = value after reset

Table 24. Register Address 19 Field Descriptions

Bit	Field	Type	Reset	Description
D6	INV SYNCb AB	R/W	0	Inverts polarity of SYNCbAB input 0 = Normal operation 1 = Polarity inverted
D5	HD AB	R/W	1	Enables high density mode for channel AB. This mode is needed for LMFS = 4221. 0 = High-density mode disabled for mode LMFS = 2221 1 = High-density mode enabled for mode LMFS = 4221 (default)
D4	SCR EN AB	R/W	0	Enables scramble mode for channel AB 0 = Scramble mode disabled (default) 1 = Scramble mode enabled

7.6.1.15 Register Address 22

Figure 87. Register Address 22, Reset: 0x0001, Hex = 16

D15	D14	D13	D12	D11	D10	D9	D8	D7	D6	D5	D4	D3	D2	D1	D0
0	0	0	0	0	0	CTRL F CD		0	0	0	0	0	0	CTRL M CD	

LEGEND: R/W = Read/Write; R = Read only; -n = value after reset

Table 25. Register Address 22 Field Descriptions

Bit	Field	Type	Reset	Description
D9:D8	CTRL F CD	R/W	00	Controls number of octets per frame for channel CD. 00: F = 1 (default) 01: F = 2
D1:D0	CTRL M CD	R/W	01	Controls number of converters per link for channel CD. 01: M = 2. This is the only valid option (default)

7.6.1.16 Register Address 23

Figure 88. Register Address 23, Reset: 0x03E3, Hex = 17

D15	D14	D13	D12	D11	D10	D9	D8	D7	D6	D5	D4	D3	D2	D1	D0	
0	0	0	0	0	0	CTRL K CD					0	0	0	CTRL L CD		

LEGEND: R/W = Read/Write; R = Read only; -n = value after reset

Table 26. Register Address 23 Field Descriptions

Bit	Field	Type	Reset	Description
D9:D5	CTRL K CD	R/W	11111	Controls number of frames per multi-frame for channel CD 0: K = 1 30 K = 31 1: K = 2 31 K = 32 (default) And so forth
D1:D0	CTRL L CD	R/W	11	Controls number of lanes for channel CD 01: L = 2 11: L = 4 (default)

7.6.1.17 Register Address 26

Figure 89. Register Address 26, Reset: 0x0020, Hex = 1A

D15	D14	D13	D12	D11	D10	D9	D8	D7	D6	D5	D4	D3	D2	D1	D0
0	0	0	0	0	0	0	0	0	INV SYNCb CD	HD CD	SCR EN CD	0	0	0	0

LEGEND: R/W = Read/Write; R = Read only; -n = value after reset

Table 27. Register Address 26 Field Descriptions

Bit	Field	Type	Reset	Description
D6	INV SYNCb CD	R/W	0	Inverts polarity of SYNCbCD input 0 = Normal operation 1 = Polarity inverted
D5	HD CD	R/W	1	Enables high density mode for channel CD. This mode is needed for LMFS = 4221. 0 = High density mode disabled for mode LMFS = 2221 1 = High density mode enabled for mode LMFS = 4221 (default)
D4	SCR EN CD	R/W	0	Enables scramble mode for channel CD 0 = Scramble mode disabled (default) 1 = Scramble mode enabled

7.6.1.18 Register Address 29
Figure 90. Register Address 29, Reset: 0x0000, Hex = 1D

D15	D14	D13	D12	D11	D10	D9	D8	D7	D6	D5	D4	D3	D2	D1	D0
0	0	0	0	0	0	0	0	0	TEST PATTERN EN CD	TEST PATTERN EN AB	0	TEST PATTERN	0	0	0

LEGEND: R/W = Read/Write; R = Read only; -n = value after reset

Table 28. Register Address 29 Field Descriptions

Bit	Field	Type	Reset	Description
D6	TEST PATTERN EN CD	R/W	0	Enables test pattern output for channel C and D 0 = Normal operation 1 = Test pattern output enabled
D5	TEST PATTERN EN AB	R/W	0	Enables test pattern output for channel A and B 0 = Normal operation 1 = Test pattern output enabled
D4	TEST PATTERN	R/W	0	Selects test pattern 0 = RAMP pattern 1 = Output alternates between 0x1555 and 0x2AAA

7.6.1.19 Register Address 30
Figure 91. Register Address 30, Reset: 0x0000, Hex = 1E

D15	D14	D13	D12	D11	D10	D9	D8	D7	D6	D5	D4	D3	D2	D1	D0
0	0	0	0	0	0	JESD SLEEP MODES – ENABLE pin									

LEGEND: R/W = Read/Write; R = Read only; -n = value after reset

Table 29. Register Address 30 Field Descriptions

Bit	Field	Type	Reset	Description
D9:D0	JESD SLEEP MODES – ENABLE pin	R/W	0 0000 0000	Power-down function assigned to ENABLE pin. When any bit is set, the corresponding function is always enabled regardless of status of the ENABLE pin. D9 = JESD PLL channel CD D8 = JESD PLL channel AB D7 = Lane DD1 D6 = Lane DD0 D5 = Lane DC1 D4 = Lane DC0 D3 = Lane DB1 D2 = Lane DB0 D1 = Lane DA1 D0 = Lane DA0

Table 30. Configurations

	Description
00 0000 0000	Global power down (default)
00 0000 0000	Standby
11 0000 0000	Deep sleep
11 0000 0000	Light sleep

7.6.1.20 Register Address 31
Figure 92. Register Address 31, Reset: 0xFFFF, Hex = 1F

D15	D14	D13	D12	D11	D10	D9	D8	D7	D6	D5	D4	D3	D2	D1	D0
1	1	1	1	1	1	JESD SLEEP MODES – SPI									

LEGEND: R/W = Read/Write; R = Read only; -n = value after reset

Table 31. Register Address 31 Field Descriptions

Bit	Field	Type	Reset	Description
D15:D0	JESD SLEEP MODES – SPI	R/W	11 1111 1111	Power-down function controlled via SPI. When a bit is set to 0, the function is powered down when ENABLE pin is high. However register 0x1E has higher priority. For example, if D9 (JESD PLL channel CD) in 0x1E is enabled, it cannot be powered down with the ENABLE pin. D9 = JESD PLL channel CD D8 = JESD PLL channel AB D7 = Lane DD1 D6 = Lane DD0 D5 = Lane DC1 D4 = Lane DC0 D3 = Lane DB1 D2 = Lane DB0 D1 = Lane DA1 D0 = Lane DA0

Table 32. Configurations

	Description
00 0000 0000	Global power down
00 0000 0000	Standby
11 0000 0000	Deep sleep
11 0000 0000	Light sleep
11 1111 1111	Normal operation (default)

Control power down function through ENABLE pin:

1. Configure power down mode in register 0x1E
2. Normal operation: ENABLE pin high
3. Power down mode: ENABLE pin low

Control power down function through SPI (ENABLE pin always high):

1. Assign power down mode in register 0x1F
2. Normal operation 0x1F is 0xFFFF
3. Power-down mode: configure power down mode in register 0x1F

7.6.1.21 Register Address 32
Figure 93. Register Address 32, Reset: 0x0000, Hex = 20

D15	D14	D13	D12	D11	D10	D9	D8	D7	D6	D5	D4	D3	D2	D1	D0
JESD LANE POLARITY INVERT								PRBS EN							

LEGEND: R/W = Read/Write; R = Read only; -n = value after reset

Table 33. Register Address 32 Field Descriptions

Bit	Field	Type	Reset	Description
D15:D8	JESD LANE POLARITY INVERT	R/W	0000 0000	Set to 1 for polarity inversion D15 = Lane DD1 D14 = Lane DD0 D13 = Lane DC1 D12 = Lane DC0 D11 = Lane DB1 D10 = Lane DB0 D9 = Lane DA1 D8 = Lane DA0
D7:D0	PRBS EN	R/W	0000 0000	Outputs PRBS pattern selected in address 0x21 on the selected serial output lanes D7 = Lane DD1 D6 = Lane DD0 D5 = Lane DC1 D4 = Lane DC0 D3 = Lane DB1 D2 = Lane DB0 D1 = Lane DA1 D0 = Lane DA0

7.6.1.22 Register Address 33
Figure 94. Register Address 33, Reset: 0x0000, Hex = 21

D15	D14	D13	D12	D11	D10	D9	D8	D7	D6	D5	D4	D3	D2	D1	D0
	PRBS SEL	0	0	0	0	0	0	0	0	0	0	0	VREF SEL		

LEGEND: R/W = Read/Write; R = Read only; -n = value after reset

Table 34. Register Address 33 Field Descriptions

Bit	Field	Type	Reset	Description
D14:D13	PRBS SEL	R/W	00	Selects different PRBS output pattern (these are not 8b/10b encoded) 000 = $2^{31} - 1$ 001 = $2^7 - 1$ 010 = $2^{15} - 1$ 011 = $2^{23} - 1$
D2:D0	VREF SEL	R/W	000	Selects different input full-scale amplitude by adjusting voltage reference setting 000 = Full scale is 1.25 Vpp (default) 001 = Full scale is 1.35 Vpp 010 = Full scale is 1.5 Vpp 011 = External 100 = Full scale is 1.15 Vpp 101 = Full scale is 1.0 Vpp

7.6.1.23 Register Address 99
Figure 95. Register Address 99, Reset: 0x0000, Hex = 63

D15	D14	D13	D12	D11	D10	D9	D8	D7	D6	D5	D4	D3	D2	D1	D0				
0	0	0	0	0	0	0	TEMP SENSOR												

LEGEND: R/W = Read/Write; R = Read only; -n = value after reset

Table 35. Register Address 99 Field Descriptions

Bit	Field	Type	Reset	Description
D8:D0	TEMP SENSOR	R	undefined	Value of on chip temperature sensor (read only). Value is 2s complement of die temperature sensor in °C For example: 0x0032 equals 50°C

7.6.1.24 Register Address 100
Figure 96. Register Address 100, Reset: 0x0000, Hex = 64

D15	D14	D13	D12	D11	D10	D9	D8	D7	D6	D5	D4	D3	D2	D1	D0
PRE EMP SEL AB				PRE EMP EN AB				DCC EN AB				0	0	0	0

LEGEND: R/W = Read/Write; R = Read only; -n = value after reset

Table 36. Register Address 100 Field Descriptions

Bit	Field	Type	Reset	Description
D15:D12	PRE EMP SEL AB	R/W	0000	Selects pre-emphasis of serializers for channel A and B 0 = Pre-emphasis 1 = De-emphasis
D11:D8	PRE EMP EN AB	R/W	0000	Enables pre-emphasis, 0 = disabled, 1 = enabled D11 = Lane DB1 D10 = Lane DB0 D9 = Lane DA1 D8 = Lane DA0
D7:D4	DCC EN AB	R/W	0000	Enables the duty cycle correction circuit for each of the serializers D7 = Lane DB1 D6 = Lane DB0 D5 = Lane DA1 D4 = Lane DA0

7.6.1.25 Register Address 103
Figure 97. Register Address 103, Reset: 0x0000, Hex = 67

D15	D14	D13	D12	D11	D10	D9	D8	D7	D6	D5	D4	D3	D2	D1	D0
OUTPUT CURRENT CONTROL AB															

LEGEND: R/W = Read/Write; R = Read only; -n = value after reset

Table 37. Register Address 103 Field Descriptions

Bit	Field	Type	Reset	Description
D15:D0	OUTPUT CURRENT CONTROL AB	R/W	0000 0000 0000 0000	Selects pre-emphasis current for the serializers. There are 4 bit per serializer of channel A and B. D15:D12 = Lane DB1 D11:D8 = Lane DB0 D7:D4 = Lane DA1 D3:D0 = Lane DA0

Table 38. Pre-Emphasis Level is: Decimal Value / 30

	Description
0000	Normal operation
0001	1 / 30
0010	2 / 30
and so forth	

7.6.1.26 Register Address 104
Figure 98. Register Address 104, Reset: 0x0000, Hex = 68

D15	D14	D13	D12	D11	D10	D9	D8	D7	D6	D5	D4	D3	D2	D1	D0
PRE EMP SEL CD				PRE EMP EN CD				DCC EN CD				0	0	0	0

LEGEND: R/W = Read/Write; R = Read only; -n = value after reset

Table 39. Register Address 104 Field Descriptions

Bit	Field	Type	Reset	Description
D15:D12	PRE EMP SEL CD		0000	Selects pre-emphasis of serializers for channel C and D 0 = Pre-emphasis 1 = De-emphasis
D11:D8	PRE EMP EN CD		0000	Enables pre-emphasis, 0 = disabled, 1 = enabled D11 = Lane DD1 D10 = Lane DD0 D9 = Lane DC1 D8 = Lane DC0
D7:D4	DCC EN CD		0000	Enables the duty cycle correction circuit for each of the serializers D7 = Lane DD1 D6 = Lane DD0 D5 = Lane DC1 D4 = Lane DC0

7.6.1.27 Register Address 107
Figure 99. Register Address 107, Reset: 0x0000, Hex = 6B

D15	D14	D13	D12	D11	D10	D9	D8	D7	D6	D5	D4	D3	D2	D1	D0
OUTPUT CURRENT CONTROL CD															

LEGEND: R/W = Read/Write; R = Read only; -n = value after reset

Table 40. Register Address 107 Field Descriptions

Bit	Field	Type	Reset	Description
D15:D0	OUTPUT CURRENT CONTROL CD	R/W	0000 0000 0000 0000	Selects pre-emphasis current for the serializers. There are 4 bit per serializer of channel C and D. D15:D12 = Lane DD1 D11:D8 = Lane DD0 D7:D4 = Lane DC1 D3:D0 = Lane DC0

Table 41. Pre-Emphasis Level is: Decimal Value / 30

	Description
0000	Normal operation
0001	1 / 30
0010	2 / 30
And so forth	

7.6.1.28 Register Address 108
Figure 100. Register Address 108, Hex = 3C

D15	D14	D13	D12	D11	D10	D9	D8	D7	D6	D5	D4	D3	D2	D1	D0
0	0	0	0	0	0	0	0	0	0	0	0	0	0	JESD PLL CD	JESD PLL AB

LEGEND: R/W = Read/Write; R = Read only; -n = value after reset

Table 42. Register Address 108 Field Descriptions⁽¹⁾

Bit	Field	Type	Reset	Description
D1	JESD PLL CD	R	1	JESD PLL for channel CD lost lock when flag is set high
D0	JESD PLL CD	R	1	JESD PLL for channel AB lost lock when flag is set high

(1) Register values in address 0x6C are read only alarms

8 Application and Implementation

NOTE

Information in the following applications sections is not part of the TI component specification, and TI does not warrant its accuracy or completeness. TI's customers are responsible for determining suitability of components for their purposes. Customers should validate and test their design implementation to confirm system functionality.

8.1 Application Information

In the design of any application involving a high-speed data converter, particular attention should be paid the design of the analog input, the clocking solution, and careful layout of the clock and analog signals. In addition, the JESD204B interface means there now are high-speed serial lines that should be handled to preserve adequate signal integrity at the device that receives the sample data. The ADS54J54 evaluation module (EVM) is one practical example of the design of the analog input circuit and clocking solution, as well as a practical example of good circuit board layout practices around the ADC.

8.2 Typical Application

The analog inputs of the ADS54J54 must be fully differential and biased to a desired common mode voltage, VCM. Therefore, there will be a signal conditioning circuit for each of the analog inputs. If the amplitude of the input circuit is such that no gain is needed to make full use of the full-scale range of the ADC, then a transformer coupled circuit as in Figure 101 may be used with good results. The transformer coupling is inherently low-noise, and inherently AC-coupled so that the signal may be biased to VCM after the transformer coupling. If signal gain is required, or the input bandwidth is to include the spectrum all the way down to DC such that AC coupling is not possible, then an amplifier-based signal conditioning circuit would be required.

By using the simple drive circuit of Figure 101, uniform performance can be obtained over a wide frequency range. The buffers present at the analog inputs of the device help isolate the external drive source from the switching currents of the sampling circuit.

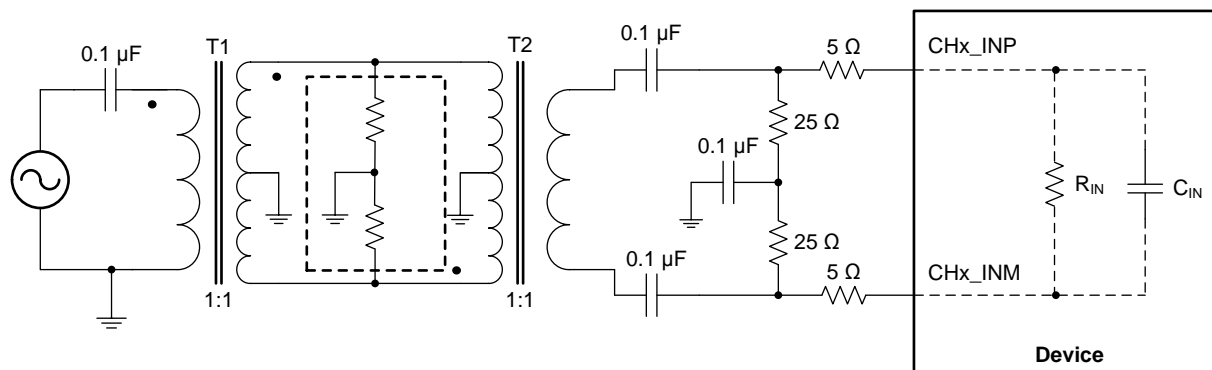

Figure 101. Input Drive Circuit

Typical Application (continued)

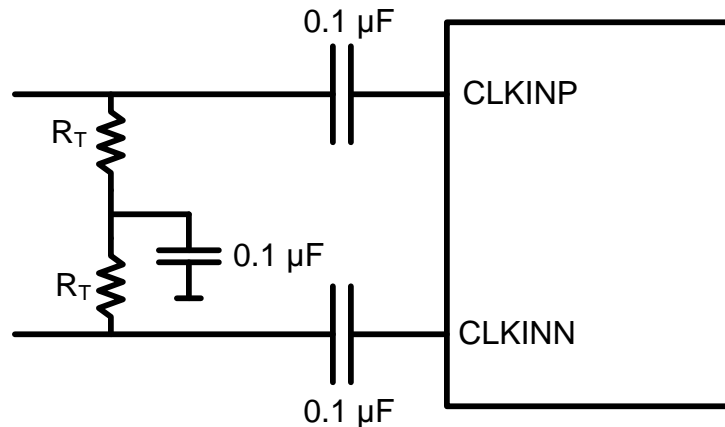

Figure 102. Recommended Differential Clock Driving Circuit

8.3 Design Requirements

The ADS54J54 requires a fully differential analog input with a full-scale range not to exceed 1.25 V peak to peak, biased to a common mode voltage of 2.0 V. In addition the input circuit must provide proper transmission line termination (or proper load resistors in an amplifier-based solution) so the input of the impedance of the ADC analog inputs should be considered as well.

The clocking solution will have a direct impact on performance in terms of SNR, as shown in [Figure 103](#). The ADS54J54 is capable of a typical SNR of 66 dBFS for input frequencies of about 100 MHz (in 14-bit bypass digital mode), so we will want to have a clocking solution that can preserve this level of performance.

8.4 Detailed Design Procedure

The ADS54J54 has an input bandwidth of approximately 900 MHz, but we will consider an application involving the first or second Nyquist zones, so we will limit the frequency bandwidth here to be under 250 MHz. We will also consider a 50-ohm signal source, so the proper termination would be 50-Ω differential. As seen in [Figure 104](#) and [Figure 105](#), the input impedance of the analog input at 250 MHz is large compared to 50 Ω, so the proper termination can be 50-Ω differential as shown in [Figure 101](#). Splitting the termination into two 25-Ω resistors with an AC capacitor to ground provides a path to filter out any ripple on the common mode that may result from any amplitude or phase imbalance of the differential input, improving SFDR performance. The ADS54J54 provides a VCM output that may be used to bias the input to the desired level, but as seen in [Figure 67](#) the signal is internally biased inside the ADC so an external biasing to VCM is not required. If an external biasing to VCM were to be employed, the VCM voltage may be applied to the mid-point of the two 25-Ω termination resistors in [Figure 101](#).

For the clock input, [Figure 103](#) shows the SNR of the device above 100 MHz begins to degrade with external clock jitter of greater than 100 fs rms, so we will recommend the clock source be limited to approximately 100 fS of rms jitter. For the ADS54J54 EVM, the LMK04828 clock device is capable of providing a low-jitter sample clock as well as providing the SYSREF signal required as shown in [Figure 62](#) and [Figure 63](#), so that clocking device is one good choice for the clocking solution for the ADS54J54.

8.4.1 SNR and Clock Jitter

The signal-to-noise ratio of the channel is limited by three different factors: the quantization noise is typically not noticeable in pipeline converters and is 84 dB for a 14-bit channel. The thermal noise limits the SNR at low input frequencies while the clock jitter sets the SNR for higher input frequencies.

$$\text{SNR}_{\text{ADC}}[\text{dBc}] = -20 \cdot \log \sqrt{\left(10^{\frac{\text{SNR}_{\text{Quantization Noise}}}{20}}\right)^2 + \left(10^{\frac{\text{SNR}_{\text{Thermal Noise}}}{20}}\right)^2 + \left(10^{\frac{\text{SNR}_{\text{Jitter}}}{20}}\right)^2} \quad (1)$$

Detailed Design Procedure (continued)

Calculate the SNR limitation due to sample clock jitter using the following:

$$SNR_{Jitter} [dBc] = -20 \cdot \log(2\pi \cdot f_{in} \cdot T_{Jitter}) \tag{2}$$

The total clock jitter (t_{Jitter}) has two components – the internal aperture jitter (98 fs for ADS54J54), which is set by the noise of the clock input buffer, the external clock jitter, and the jitter from the analog input signal. Calculate total clock jitter using the following:

$$T_{Jitter} = \sqrt{(T_{Jitter,Ext.Clock_Input})^2 + (T_{Aperture_ADC})^2} \tag{3}$$

External clock jitter can be minimized by using high quality clock sources and jitter cleaners, as well as bandpass filters at the clock input while a faster clock slew rate improves the channel aperture jitter.

The ADS54J54 has a thermal noise of 66 dBFS and internal aperture jitter of 98 fs. The SNR depending on amount of external jitter for different input frequencies is shown in [Figure 103](#).

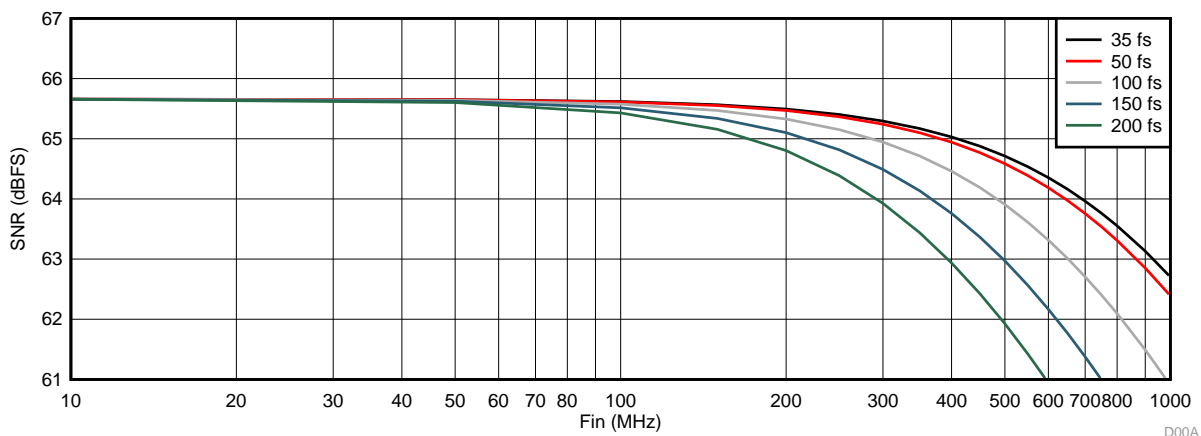

Figure 103. SNR vs Input Frequency and External Clock Jitter

8.5 Application Curves

[Figure 104](#) and [Figure 105](#) show the differential impedance between the channel INP and INM pins. The impedance is modeled as a parallel combination of RIN and CIN ($RIN \parallel 1 / j\omega CIN$).

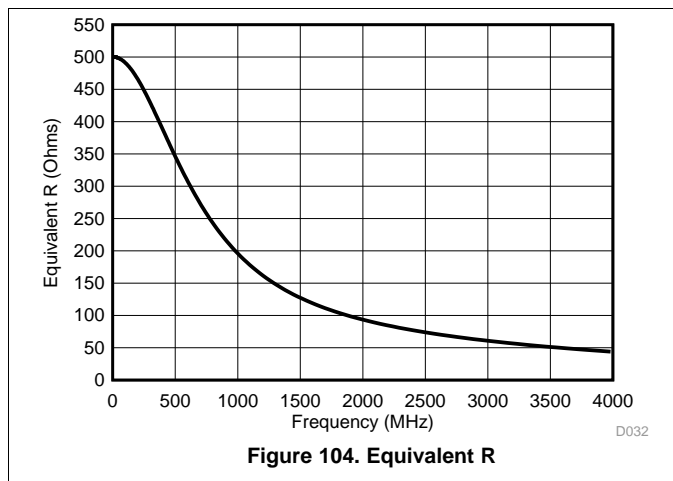

Figure 104. Equivalent R

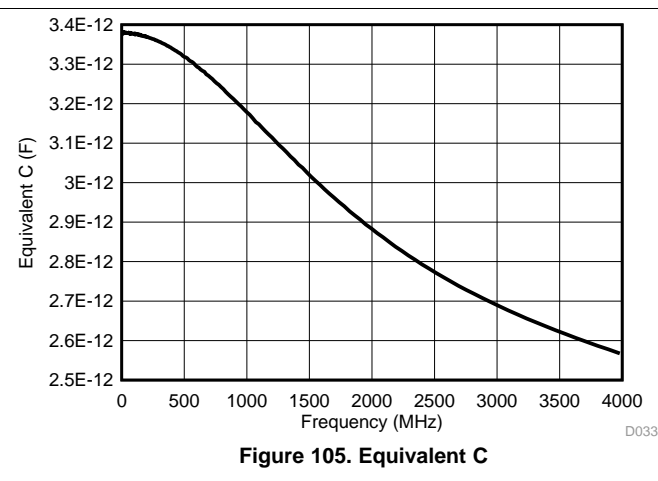

Figure 105. Equivalent C

9 Power Supply Recommendations

The device requires a 1.8-V nominal supply for AVDDC, IOVDD, PLLVDD, and DVDD. The device also requires a 1.9-V supply for AVDD18 and a 3.3-V supply for AVDD33. There are no specific sequence power-supply requirements during device power-up. AVDD, DVDD, IOVDD, PLLVDD, and AVDD33 can power up in any order.

10 Layout

10.1 Layout Guidelines

The Device EVM layout can be used as a reference layout to obtain the best performance. A layout diagram of the EVM top layer is provided in [Figure 107](#). Some important points to remember during laying out the board are:

- Analog inputs are located on opposite sides of the device pinout to ensure minimum crosstalk on the package level. To minimize crosstalk on-board, the analog inputs should exit the pinout in opposite directions, as shown in the reference layout of [Figure 107](#) as much as possible.
- In the device pinout, the sampling clock is located on a side perpendicular to the analog inputs in order to minimize coupling between them. This configuration is also maintained on the reference layout of [Figure 107](#) as much as possible.
- Digital outputs should be kept away from the analog inputs. When these digital outputs exit the pinout, the digital output traces should not be kept parallel to the analog input traces because this configuration may result in coupling from digital outputs to analog inputs and degrade performance. The digital sample data rate can be as high as 5.0 Gbps, so care must be taken to maintain the signal integrity of these signals. A low-loss dielectric circuit board is recommended or else these traces should be kept as short as possible. These traces should be kept away from the analog inputs and clock input to the device as well.
- At each power-supply pin, a 0.1- μ F decoupling capacitor should be kept close to the device. A separate decoupling capacitor group consisting of a parallel combination of 10- μ F, 1- μ F, and 0.1- μ F capacitors can be kept close to the supply source.

10.1.1 CML SerDes Transmitter Interface

Each of the 5 Gbps SerDes CML transmitter outputs requires AC coupling between transmitter and receiver. The differential pair should be terminated with a 100- Ω resistor as close to the receiving device as possible to avoid unwanted reflections and signal degradation.

10.2 Layout Example

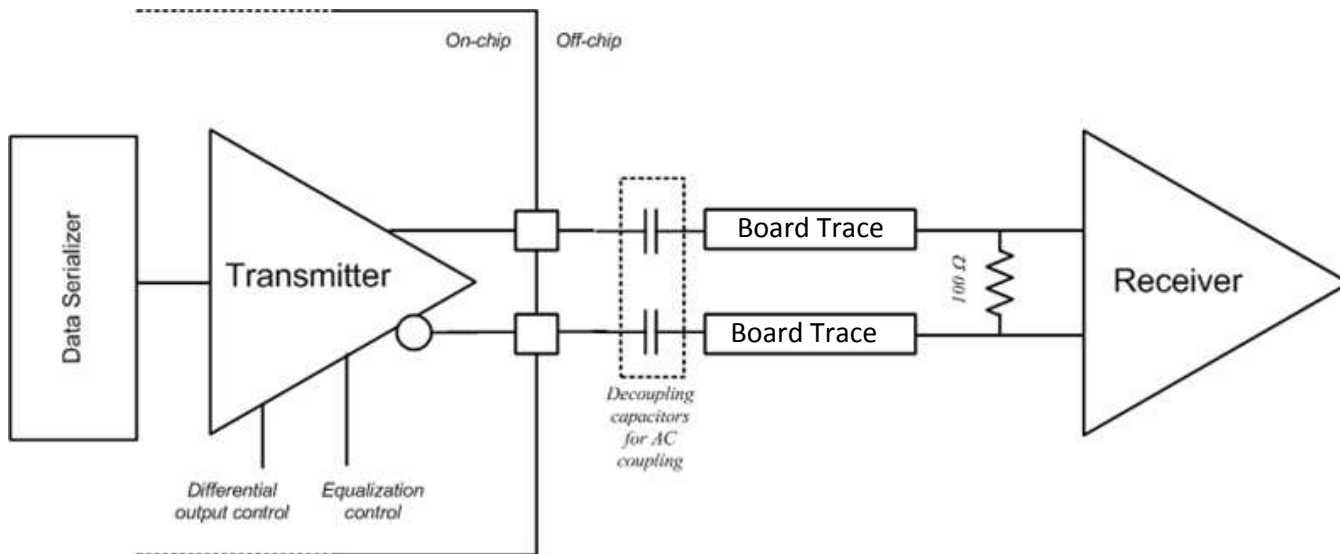

Figure 106. Layout Example Schematic

Layout Example (continued)

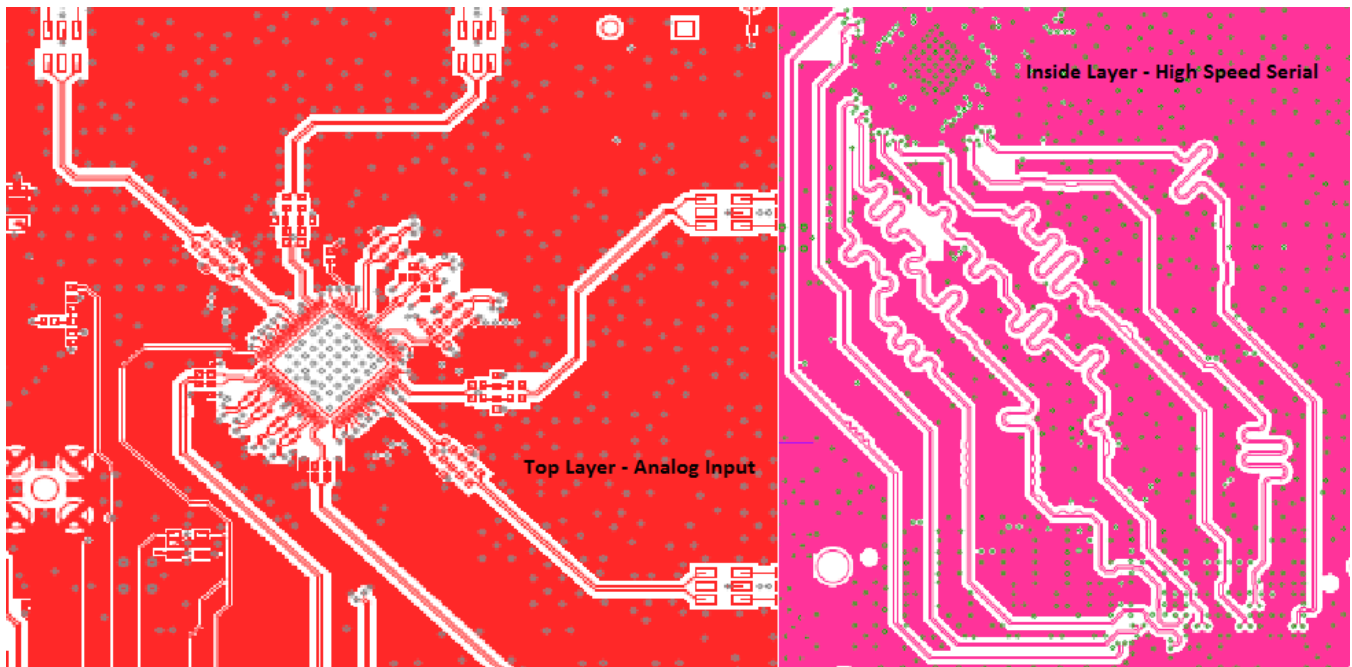

Figure 107. Top and Bottom Layers

11 Device and Documentation Support

11.1 Trademarks

PowerPAD is a trademark of Texas Instruments.

11.2 Electrostatic Discharge Caution



These devices have limited built-in ESD protection. The leads should be shorted together or the device placed in conductive foam during storage or handling to prevent electrostatic damage to the MOS gates.

11.3 Glossary

[SLYZ022](#) — *TI Glossary*.

This glossary lists and explains terms, acronyms, and definitions.

12 Mechanical, Packaging, and Orderable Information

The following pages include mechanical, packaging, and orderable information. This information is the most current data available for the designated devices. This data is subject to change without notice and revision of this document. For browser-based versions of this data sheet, refer to the left-hand navigation.

PACKAGING INFORMATION

Orderable Device	Status (1)	Package Type	Package Drawing	Pins	Package Qty	Eco Plan (2)	Lead finish/ Ball material (6)	MSL Peak Temp (3)	Op Temp (°C)	Device Marking (4/5)	Samples
ADS54J54IRGCR	ACTIVE	VQFN	RGC	64	2000	RoHS & Green	NIPDAUAG	Level-3-260C-168 HR	-40 to 85	AZ54J54	Samples
ADS54J54IRGCT	ACTIVE	VQFN	RGC	64	250	RoHS & Green	NIPDAUAG	Level-3-260C-168 HR	-40 to 85	AZ54J54	Samples

(1) The marketing status values are defined as follows:

ACTIVE: Product device recommended for new designs.

LIFEBUY: TI has announced that the device will be discontinued, and a lifetime-buy period is in effect.

NRND: Not recommended for new designs. Device is in production to support existing customers, but TI does not recommend using this part in a new design.

PREVIEW: Device has been announced but is not in production. Samples may or may not be available.

OBSOLETE: TI has discontinued the production of the device.

(2) **RoHS:** TI defines "RoHS" to mean semiconductor products that are compliant with the current EU RoHS requirements for all 10 RoHS substances, including the requirement that RoHS substance do not exceed 0.1% by weight in homogeneous materials. Where designed to be soldered at high temperatures, "RoHS" products are suitable for use in specified lead-free processes. TI may reference these types of products as "Pb-Free".

RoHS Exempt: TI defines "RoHS Exempt" to mean products that contain lead but are compliant with EU RoHS pursuant to a specific EU RoHS exemption.

Green: TI defines "Green" to mean the content of Chlorine (Cl) and Bromine (Br) based flame retardants meet JS709B low halogen requirements of <=1000ppm threshold. Antimony trioxide based flame retardants must also meet the <=1000ppm threshold requirement.

(3) MSL, Peak Temp. - The Moisture Sensitivity Level rating according to the JEDEC industry standard classifications, and peak solder temperature.

(4) There may be additional marking, which relates to the logo, the lot trace code information, or the environmental category on the device.

(5) Multiple Device Markings will be inside parentheses. Only one Device Marking contained in parentheses and separated by a "~" will appear on a device. If a line is indented then it is a continuation of the previous line and the two combined represent the entire Device Marking for that device.

(6) Lead finish/Ball material - Orderable Devices may have multiple material finish options. Finish options are separated by a vertical ruled line. Lead finish/Ball material values may wrap to two lines if the finish value exceeds the maximum column width.

Important Information and Disclaimer:The information provided on this page represents TI's knowledge and belief as of the date that it is provided. TI bases its knowledge and belief on information provided by third parties, and makes no representation or warranty as to the accuracy of such information. Efforts are underway to better integrate information from third parties. TI has taken and continues to take reasonable steps to provide representative and accurate information but may not have conducted destructive testing or chemical analysis on incoming materials and chemicals. TI and TI suppliers consider certain information to be proprietary, and thus CAS numbers and other limited information may not be available for release.

In no event shall TI's liability arising out of such information exceed the total purchase price of the TI part(s) at issue in this document sold by TI to Customer on an annual basis.

TAPE AND REEL INFORMATION

QUADRANT ASSIGNMENTS FOR PIN 1 ORIENTATION IN TAPE

*All dimensions are nominal

Device	Package Type	Package Drawing	Pins	SPQ	Reel Diameter (mm)	Reel Width W1 (mm)	A0 (mm)	B0 (mm)	K0 (mm)	P1 (mm)	W (mm)	Pin1 Quadrant
ADS54J54IRGCR	VQFN	RGC	64	2000	330.0	16.4	9.3	9.3	1.5	12.0	16.0	Q2

TAPE AND REEL BOX DIMENSIONS

*All dimensions are nominal

Device	Package Type	Package Drawing	Pins	SPQ	Length (mm)	Width (mm)	Height (mm)
ADS54J54IRGCR	VQFN	RGC	64	2000	350.0	350.0	43.0

GENERIC PACKAGE VIEW

RGC 64

VQFN - 1 mm max height

9 x 9, 0.5 mm pitch

PLASTIC QUAD FLATPACK - NO LEAD

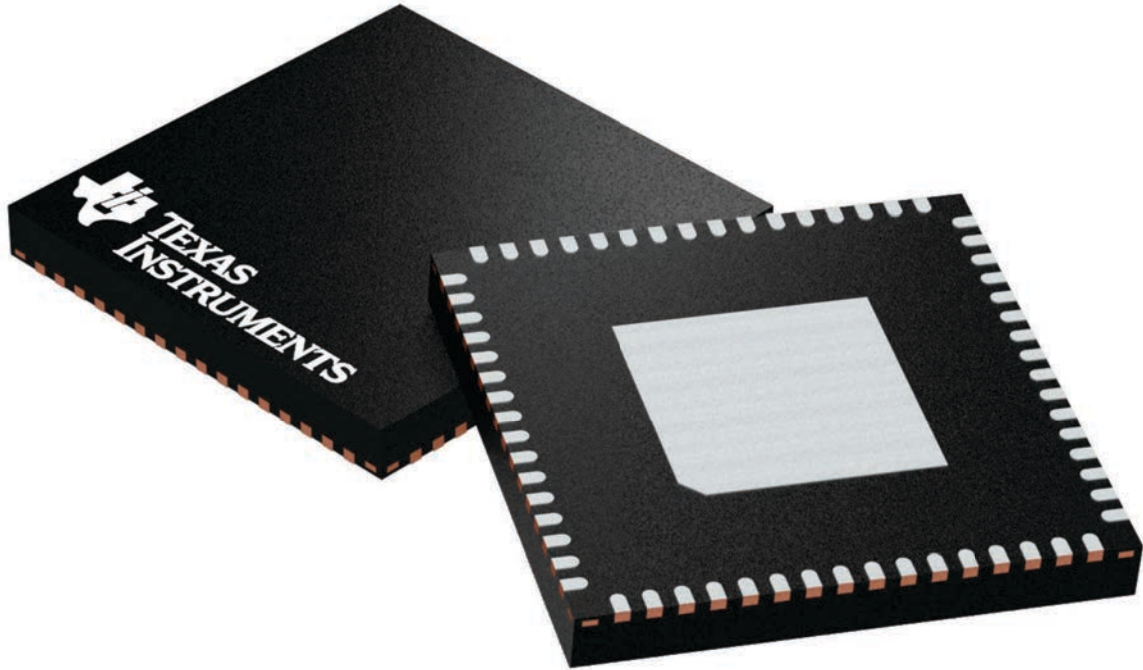

Images above are just a representation of the package family, actual package may vary.
Refer to the product data sheet for package details.

4224597/A

RGC0064H

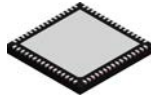

PACKAGE OUTLINE

VQFN - 1 mm max height

PLASTIC QUAD FLATPACK - NO LEAD

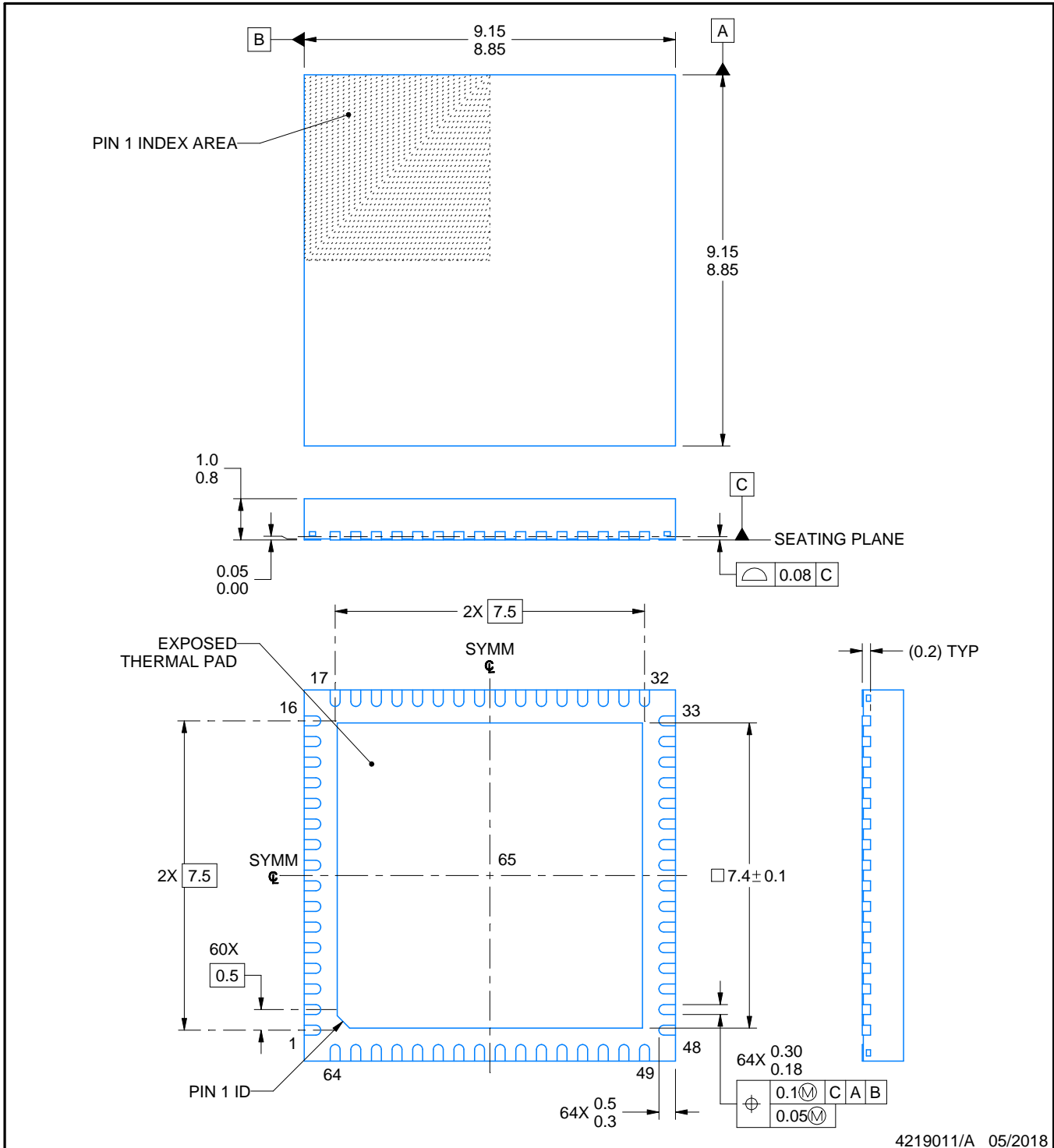

NOTES:

1. All linear dimensions are in millimeters. Any dimensions in parenthesis are for reference only. Dimensioning and tolerancing per ASME Y14.5M.
2. This drawing is subject to change without notice.
3. The package thermal pad must be soldered to the printed circuit board for thermal and mechanical performance.

EXAMPLE BOARD LAYOUT

RGC0064H

VQFN - 1 mm max height

PLASTIC QUAD FLATPACK - NO LEAD

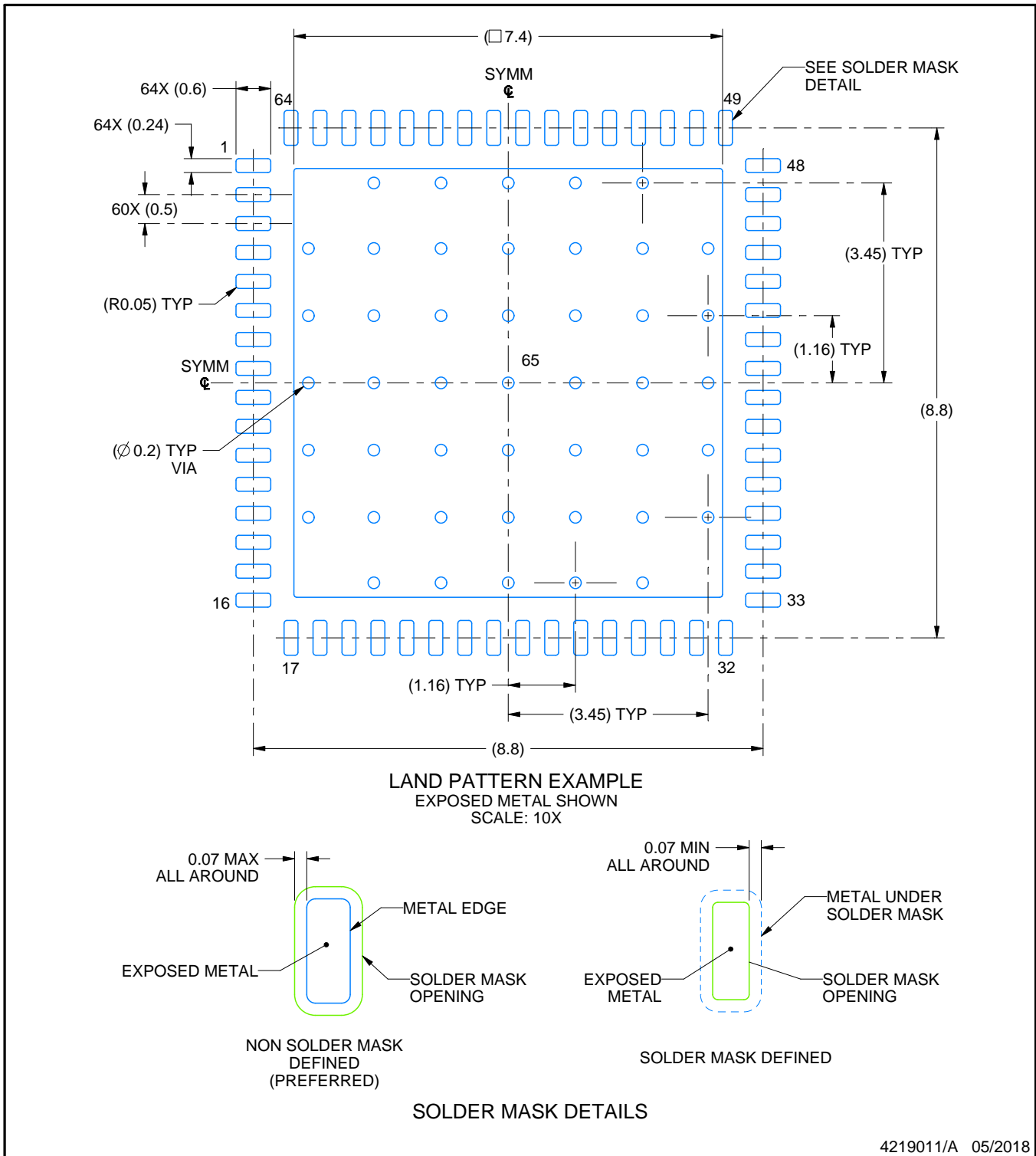

NOTES: (continued)

- This package is designed to be soldered to a thermal pad on the board. For more information, see Texas Instruments literature number SLUA271 (www.ti.com/lit/sluea271).
- Vias are optional depending on application, refer to device data sheet. If any vias are implemented, refer to their locations shown on this view. It is recommended that vias under paste be filled, plugged or tented.

EXAMPLE STENCIL DESIGN

RGC0064H

VQFN - 1 mm max height

PLASTIC QUAD FLATPACK - NO LEAD

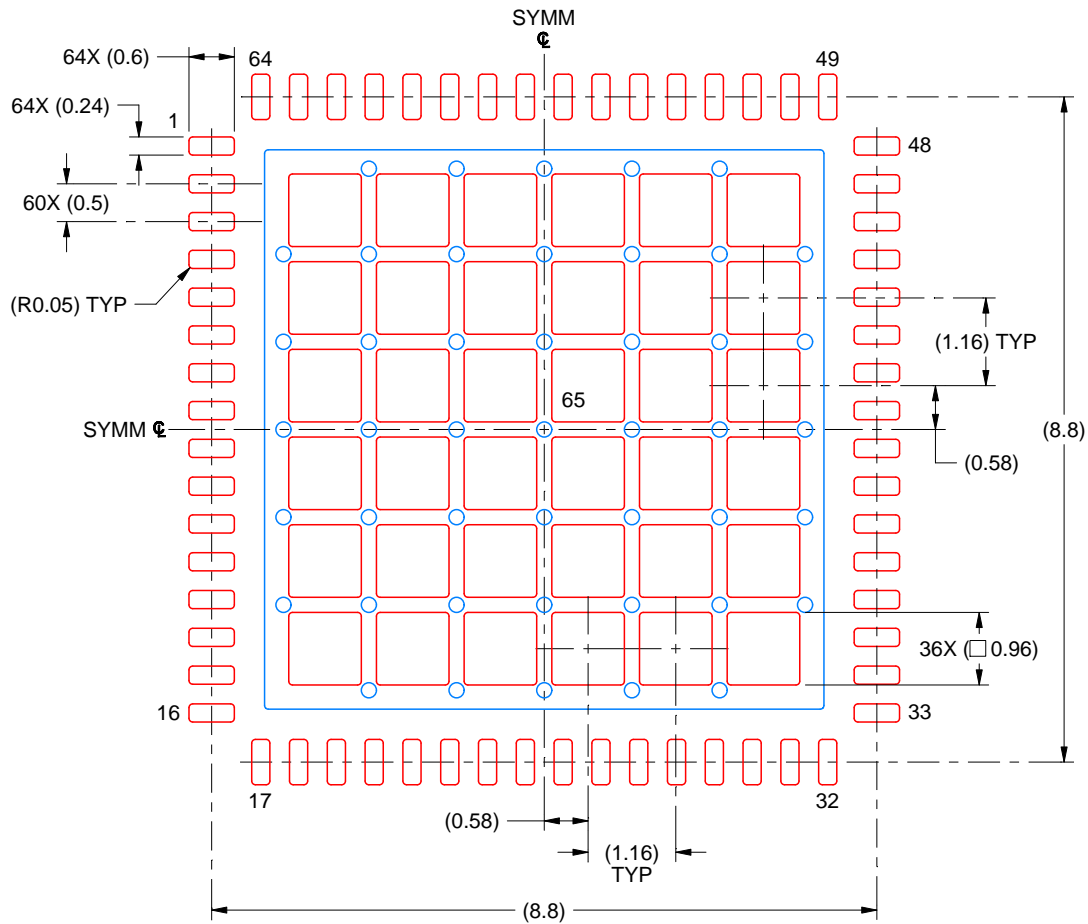

SOLDER PASTE EXAMPLE
 BASED ON 0.125 MM THICK STENCIL
 SCALE: 10X

EXPOSED PAD 65
 61% PRINTED SOLDER COVERAGE BY AREA UNDER PACKAGE

4219011/A 05/2018

NOTES: (continued)

6. Laser cutting apertures with trapezoidal walls and rounded corners may offer better paste release. IPC-7525 may have alternate design recommendations.

IMPORTANT NOTICE AND DISCLAIMER

TI PROVIDES TECHNICAL AND RELIABILITY DATA (INCLUDING DATA SHEETS), DESIGN RESOURCES (INCLUDING REFERENCE DESIGNS), APPLICATION OR OTHER DESIGN ADVICE, WEB TOOLS, SAFETY INFORMATION, AND OTHER RESOURCES "AS IS" AND WITH ALL FAULTS, AND DISCLAIMS ALL WARRANTIES, EXPRESS AND IMPLIED, INCLUDING WITHOUT LIMITATION ANY IMPLIED WARRANTIES OF MERCHANTABILITY, FITNESS FOR A PARTICULAR PURPOSE OR NON-INFRINGEMENT OF THIRD PARTY INTELLECTUAL PROPERTY RIGHTS.

These resources are intended for skilled developers designing with TI products. You are solely responsible for (1) selecting the appropriate TI products for your application, (2) designing, validating and testing your application, and (3) ensuring your application meets applicable standards, and any other safety, security, regulatory or other requirements.

These resources are subject to change without notice. TI grants you permission to use these resources only for development of an application that uses the TI products described in the resource. Other reproduction and display of these resources is prohibited. No license is granted to any other TI intellectual property right or to any third party intellectual property right. TI disclaims responsibility for, and you will fully indemnify TI and its representatives against, any claims, damages, costs, losses, and liabilities arising out of your use of these resources.

TI's products are provided subject to [TI's Terms of Sale](#) or other applicable terms available either on [ti.com](https://www.ti.com) or provided in conjunction with such TI products. TI's provision of these resources does not expand or otherwise alter TI's applicable warranties or warranty disclaimers for TI products.

TI objects to and rejects any additional or different terms you may have proposed.

Mailing Address: Texas Instruments, Post Office Box 655303, Dallas, Texas 75265
Copyright © 2023, Texas Instruments Incorporated